



Scanned from the collections of  
The Library of Congress



Packard Campus  
for Audio Visual Conservation  
[www.loc.gov/avconservation](http://www.loc.gov/avconservation)

Motion Picture and Television Reading Room  
[www.loc.gov/rr/mopic](http://www.loc.gov/rr/mopic)

Recorded Sound Reference Center  
[www.loc.gov/rr/record](http://www.loc.gov/rr/record)



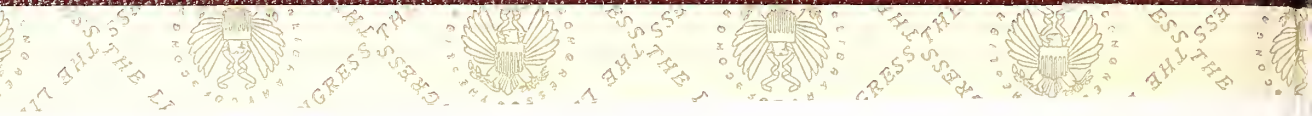



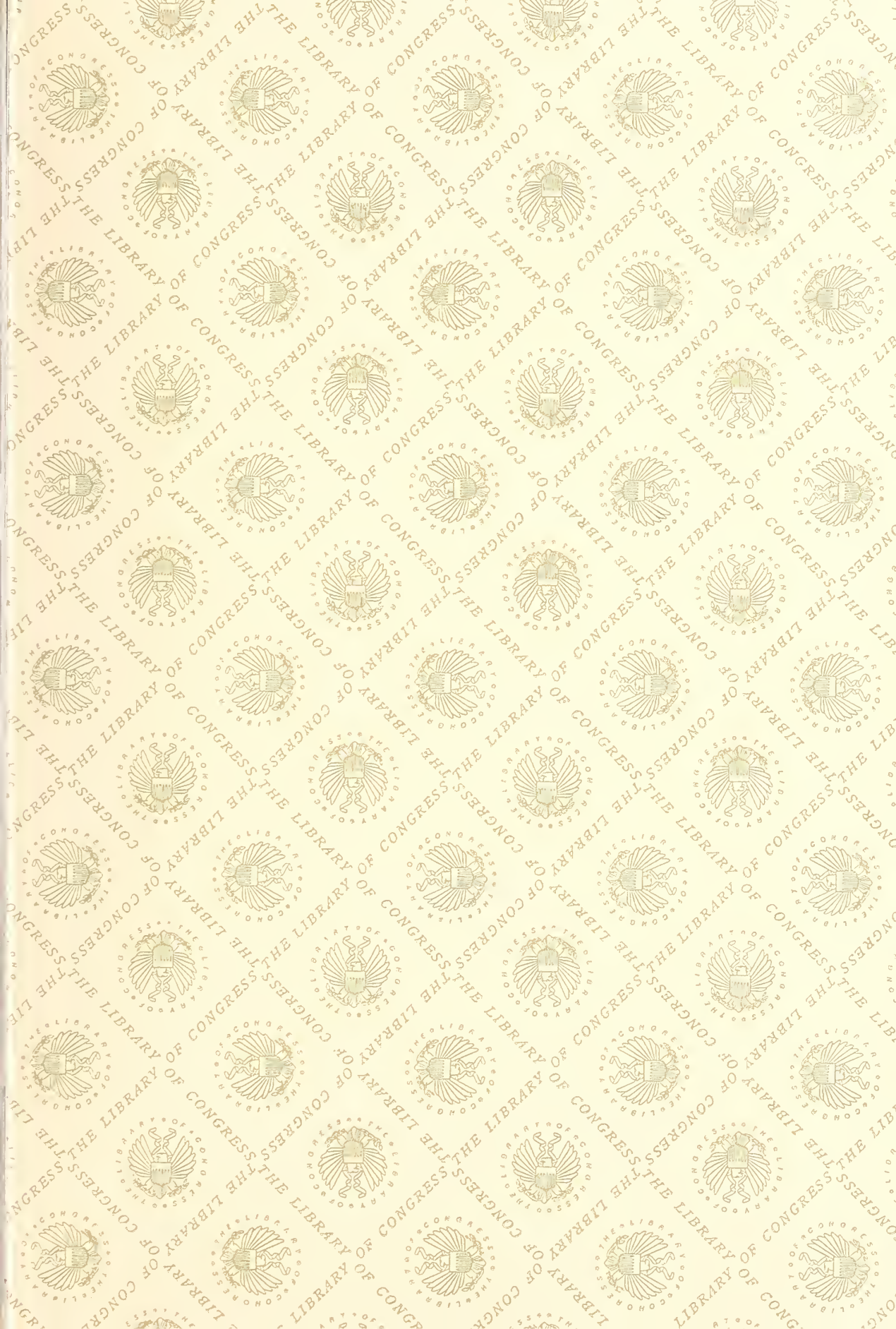







# RADIO BROADCAST

## VOLUME III

*MAY, 1923, to OCTOBER, 1923*

BETTER RADIO



GARDEN CITY      NEW YORK  
DOUBLEDAY, PAGE & COMPANY

1923



TK 6540  
R

*Copyright, 1923, by*  
DOUBLEDAY, PAGE & COMPANY

# INDEX

(\*Illustrated Articles. Editorials in Italics)

	PAGE		PAGE
<b>A</b> CCURATE <i>Measurement of Signals, The</i>	97	Will the Composer Pay for Broad-	
*Adding Two Steps to Your Aeriola		casting?.....	271
Senior (Jacques H. Herts).....	52	<i>Will the Entire Nation Listen to the</i>	
Adventures in Radio:		<i>Next President's Inaugural Address?</i>	13
When Messina was Destroyed.....	303	Broadcasting Stations:	
*Adventures on an American Yacht in Mexico		<i>Broadcast Central Comprising WJZ</i>	
(A. Henry).....	149	<i>and WJY</i> .....	274
All Boy Scouts, Attention!.....	66,166,335	*Broadcasters in New York, Paris, and	
*Among the "Hams".....	65	Los Angeles.....	429
Amateurs Taking the Code Test at the		*Have You Heard These Stations Yet?	33
Hotel Pennsylvania, New York....	65	*Highlights in the History of WDAP	
Officers and Members of the Mil-		(J. Elliott Jenkins).....	411
waukee Amateurs' Radio Club....	65	*New Station at Washington, D. C.,	
2nd District Amateurs' 1923 Banquet		A (Pierre Boucheron).....	494
at the Hotel Pennsylvania, The....	64	Revised List of U. S. and Canadian	
*Among Our Authors.....	264,356,442,534	Broadcasting Stations.....	78
As the Radio Corporation Sees the Patent		Supplemental List of Broadcasting	
Situation.....	4	Stations in the U. S., March 19, to	
Atchison, Kansas Takes Control of Radio....	12	April 20, 1923.....	174
*BEST Battery Connections for the Circuit		Supplemental List of Broadcasting	
You Use, The (Edward Lindley		Stations in the United States, April	
Bowles).....	123	21 to May 17, Inclusive.....	260
*Better Broadcast Receiver, A (Arthur L.		Supplemental List of Broadcasting	
Munzig).....	477	Stations in the United States, May	
Bit About Books, A.....	165	18 to June 15, Inclusive.....	352
*Bit About Myself, A ("Roxie"—S. L.		Supplemental List of Broadcasting	
Rothafel).....	459	Stations in the United States,	
Books:		June 16, to July 13, Inclusive.....	438
Bit About Books, A.....	165	Supplemental List of Broadcasting	
<i>Boosting the Box-Office Receipts at the Opera</i> ....	10	Stations in the United States	
Boy Scouts:		Licensed from July 14 to August 7,	
All Boy Scouts Attention!.....	66,166,335	Inclusive.....	523
Boy Scouts' Receiving Contest.....	240	*With the Broadcasters.....	135
<i>Help the Boy Scout With His Radio</i> ....	99	<i>Buying Sets on the Installment Plan</i> .....	269
<i>Broadcast Central Comprising WJZ and WJY</i>	274	<b>C</b> HINA:	
Broadcast Receiving Contest.....	73,164	<i>Radio Sets Are Contraband in</i>	
*Broadcasters in New York, Paris, and Los		<i>China</i> .....	14
Angeles.....	429	*Choosing Your Regenerative Circuit (Paul	
Broadcasting:		F. Godley).....	155
Broadcast Receiving Contest.....	73,164	Code:	
<i>Commercial Broadcasting In Germany</i> .....	100	*Learning the Code (William Harris,	
<i>Effect of Broadcasting on the Churches,</i>		Jr.).....	113
<i>The</i> .....	273	*Radio Code with Eleven Million	
<i>Effect of Broadcasting on Sermons and</i>		Variations, A (S. R. Winters).....	62
<i>Speeches, The</i> .....	6	<i>Commercial Broadcasting in Germany</i> .....	100
*Giving the Public a Light-Socket		*Concerts for All in a Veterans' Hospital	
Broadcasting Service (William		(J. Townsend Bradley).....	147
Harris, Jr.).....	465	Condensers:	
*Is Short-Wave Relaying a Step Toward		*What You Should Know About	
National Broadcasting?		Condensers.....	430,510
(W. W. Rodgers).....	119	*Confessions of an Unmade Man (R. O.	
<i>Is Wired Wireless the Future of Broad-</i>		Jaspersen).....	20
<i>casting?</i> .....	457	Contests:	
New Wavelengths for Class B Stations		All Boy Scouts Attention!.....	66,166,335
<i>Ocean to Ocean Broadcasting</i> .....	447	Broadcast Receiving Contest!.....	73,164
*Supplying Broadcasts Like Gas or		*Crystal Receivers are Well Worth While	
Electricity (Grayson L. Kirk).....	35	(Zeh Bouck).....	319
*Teaching School from a Broadcasting		<b>D</b> EAF Ears Hear Again.....	362
Station (Lloyd Jacquet).....	331	<i>De Forest Company Beaten by the Westing-</i>	
<i>What is the Range of a Broadcasting</i>		<i>house Company</i> .....	452
<i>Station?</i> .....	11		



## INDEX—Continued

	PAGE		PAGE
<i>Demand for Educational Radio, A Big</i> .....	94	<i>Hoodwinking the Listeners-In</i> .....	93
*Dry Cells and UV-199's (E. E. Horine).....	247	*How Vacuum Tubes Are Made (W. W. Rodgers).....	397
*Dry-Cell Tube Loop Set for Local Reception, A (Alex V. Polson).....	288		
<b>E</b> FFECT of Broadcasting on the Churches, The.....	273	<b>I</b> N THE R.B. Lab.....	520
<i>Effect of Broadcasting on Sermons and Speeches, The</i> .....	6	*Building Your Own Laboratory.....	522
*Eighteen Years of Amateur Radio (George E. Burghard).....	291	*Making Your Grid-Leaks.....	521
<i>Electron and its Discoverer, The</i> .....	181	*Playing with the Grimes Circuit.....	520
England:		*In the Wake of the Contest Winners.....	477
<i>Radio an Auto Accessory in Jolly Old England</i> .....	364	*In Touch with the World from the Arctic (F. Burnham McLeary).....	283
		*In Tune with the Infinite (Eric G. Shalkhauser).....	417
		<i>Increased Speed of Radio Traffic</i> .....	100
		<i>Interdepartmental Radio Advisory Committee, The</i> .....	278
		International Law and the Sea-Going Telegrapher (Claude Cathcart Levin).....	159
		Inverse Duplex:	
*FIVE-TUBE Receiver that "Delivers the Goods", A (E. D. Harrington).....	234	*Grimes Circuit with Outdoor Antenna and Counterpoise, The (Herbert E. Dill).....	314
<i>"Frail Sole" Is Carried Across Continent to Composer's First Instructor</i> .....	366	*Using the "Inverse Duplex" with the Various Kinds of Tubes (David H. Grimes).....	197
		*Is Short-Wave Relaying a Step Toward National Broadcasting Stations? (W. W. Rodgers).....	119
		<i>Is Wired Wireless the Future of Broadcasting?</i>	457
<b>G</b> ERMANY:		<b>L</b> EARNING the Code (William Harris, Jr.).....	113
<i>Commercial Broadcasting in Germany</i> .....	100	* <i>Leviathan Breaks Some Records, The</i> .....	454
*Giving the Public a Light-Socket Broadcasting Service (William Harris, Jr.).....	465	*Little Foresight and a Big Success, A (Alfred M. Caddell).....	406
<i>Good News for Our Readers</i> .....	281	*Loop Receiver in the Tropics, A (Charles T. Whitefield).....	132
*Grid, The—Questions & Answers			
Adapting Your 3-Circuit Receiver to the New Wavelengths.....	435	*M <small>AKING</small> Radio Your Business (Carl Dreher).....	190
A. C. For Receiving Filaments.....	168	*Man Who Built a Set He has Never Seen, A (Alfred M. Caddell).....	128
Amplifying Phonograph Music.....	532	* <i>Man Who Knew Lincoln, A</i> .....	455
Antenna Corrosion and Resistance.....	436	* <i>March of Radio, The</i> (J. H. M.).....	3,91,179,269,359,447
Artificial Strays.....	86	<i>Marconi Making Progress with His Short Waves</i> .....	363
Audio Amplifying Circuits.....	256	*Millionaire's Cruise on an Operator's Pay, A (A. Henry).....	222
Farm Lighting Plants and Radio.....	258	<i>More Injunctions for the Broadcasters</i> .....	180
"Flivver" Set, The.....	258	<i>Music Publishers With Vision</i> .....	270
Head-Sets and Resistance.....	170		
Interference and Fading Caused by a Near-by Set.....	350	<b>N</b> EIGHBOR at Three Thousand Miles, A (Richard Bartholomew).....	305
Loops.....	168	*"Neutrodyne" Receiving System, The (Kimball H. Stark).....	38
Loops, Crystal Detectors, and Loud-Talkers.....	174	*New Equipment:	
Multi-layer Coils and Induction.....	256	Audiophone Jr., The.....	176
Operating Loud-Speakers at a Distance "Peanut Tube," The.....	172	Broadcast Receiver Employing the Neutrodyne Principle, A (Mortimer Radio Corp'n).....	524
Polarity.....	530	Burgess B Battery.....	354
Small vs Large Wire in Receiving Sets.....	172	CR-12 (A. H. Grebe).....	440
Substituting Loops on Standard Receivers.....	436	Cardwell Variable Condenser.....	354
Summer Receiving Conditions and the Ideal Set.....	350	Cutler-Hammer Co. Standard Rheostat.....	354
Three-Circuit Layout With Amplifier, A.....	528	Durable UV-199 Socket.....	262
Trouble with a Four-Step Amplifier..	530	Everready "Three" Radio Battery (National Carbon Co.).....	524
Tuned Circuits.....	79	Filament Lighting from a Lamp Socket (Simplex Electrical Laboratories, Inc.).....	526
Tuned Plate Circuit, A.....	526	For Cutting Out Interference (Malone-Lemmon).....	440
Winding Spider-Web Coils.....	528	Friction-Contact Variocoupler (Pearlco).....	440
*Grimes Circuit with Outdoor Antenna and Counterpoise, The (Herbert E. Dill).....	314		
*"HAM" Set of an Old Ship Operator, The (Zeh Bouck).....	23		
*Have You Heard These Stations Yet?.....	33		
CKAC, Montreal, Can.....	33		
WGR, Buffalo, N. Y.....	34		
WGY, Schenectady, N. Y.....	34		
Hearing North America (Abby M. White).....	421		
<i>Help the Boy Scout with His Radio</i> .....	99		
*Highlights in the History of WDAP (J. Elliott Jenkins).....	411		
*Home-Made Amplifier for Any Receiver, A (Zeh Bouck).....	230		
*Home-Made Three-Tube Outfit, A (L. Reith).....	486		

INDEX—Continued

	PAGE		PAGE
G. E. Portable Receiver	262	<i>Radio Repays its Genius</i>	279
McNeary Radio Scalometer	262	<i>Radio Sets are Contraband in China</i>	14
Music Master, The	88	Receiving Contest Winners	416
New Holtzer-Cabot Phones	354	*Recent Broadcasters in New York Studios (3 photos)	246
New Pacent Variable Condenser, The	176	*Reception de Luxe (A. R. Boscow)	324
Pacent Rheostat, The	88	*Reducing the Guesswork in Tuning (J. H. Dellinger)	241
"Paragon" Stage Control Switch	262	*Regenerative Radio-Frequency Combination, A New (Roger A. Weaver)	346
Paragon Tuned R. F. Amplifier	176	Revised List of U. S. and Canadian Broadcasting Stations	78
Pathe Loud Speaker, The	176	Rheostats for the Tubes You Use (Zeh Bouck)	496
Post Electric Soldering Iron	354		
R. M. C. Variocoupler (Radio Mfg. Co.)	524	<b>S</b> OS in the Jungle of Indo-China, An (Leland L. Smith)	42
Socket for the WD-11, A	88	*Search for a Telephone as Sensitive as the Ear, A (George B. Crouse)	142
Sonochorde, The	88	<i>Secretary Hoover Acts</i>	277
Symphony Receiver, The (Kellogg Switchboard & Supply)	440	*"Selling" the Public on Better City Government (J. L. Simpson)	299
Tuned R. F. Transformer (Workrite Mfg. Co.)	524	<i>Service Is Necessary</i>	367
Two-In-One Socket (Alden-Napier)	440	*Set the Boy and His Dad Made, The (Arthur N. King)	210
Vernier Variometer, A (National Chelsea Radio Corporation)	524	*Set with a Tuned R. F. Amplifier, A, (J. W. Denning)	484
*New Station at Washington, D. C., A (Pierre Boucheron)	494	*Set You'll Like to Make, A (Frank Nelem)	480
<i>New Station for Sweden, A</i>	100	*Set-Backs and Come-Backs at 6KW (Frank H. Jones)	368
<i>New Super-Cable</i>	456	*Sets for the Great Outdoors (A. Henry)	336
New Wavelengths for Class B Stations	167	<i>Simplified Receiving Sets</i>	449
<b>O</b> CEAN to Ocean Broadcasting	447	*Single-Tube Loop Set in a Brief-Case, A (Walter VanB. Roberts)	16
<i>Old Radio Company Changes Hands, An</i>	189	*Six-Inch Dry Cells and WD-11 Tubes (E. E. Horine)	74
*Operating a Loud Speaker on One Tube, Without Batteries (Walter Van B. Roberts)	108	<i>Size of Radio Audiences, The</i>	451
<i>Opportunity, An</i>	189	*Soldering Your Own (W. S. Standiford)	161
<i>Outdoor Experimenting in Vacation-Time</i>	91	*Some Notes on Tuned Circuits (M. B. Sleeper)	404
<b>P</b> ATENTS:		*Some Pictures the Contest Brought In (4 pictures with captions)	492
<i>As the Radio Corporation Sees the Patent Situation</i>	4	<i>Still Trouble from Interference?</i>	360
*Protecting Your Invention (Roger Sherman Hoar)	136	*Stormy P. M. at Alice's, A (Willard Wilson)	112
Putting Your Patent Across (Roger Sherman Hoar)	205	Summary of Receiving Contest Entries Arranged in Order of Mileages	489
*What Can Be Patented? (Roger Sherman Hoar)	55	<i>Sunrise and Sunset Barrier to Signals, The</i>	8
*Portable Set for Lonely Hotel Hours, A (J. T. N.)	219	Super-Heterodyne:	
*Porto Rico Fan Wins "How Far?" Contest	304	*Practical Super-Heterodyne with 199's (Walter VanB. Roberts)	340
<i>Possibility of Re-Broadcasting, The</i>	187	Supplemental List of Broadcasting Stations in the U. S. March 19 to April 20 Inclusive	174
*Powel Crosley, Jr.—"The Henry Ford of Radio" (Alvin R. Plough)	323	Supplemental List of Broadcasting Stations in the United States April 21 to May 17, Inclusive	260
*Practical Super-Heterodyne with 199's, A (Walter Van B. Roberts)	340	Supplemental List of Broadcasting Stations in the United States May 18 to June 15, Inclusive	352
<i>Preparing for Long Distance</i>	361	Supplemental List of Broadcasting Stations in the United States, June 16 to July 13, Inclusive	438
<i>President Harding Over Wire and Radio</i>	359	Supplemental List of Broadcasting Stations in the United States Licensed from July 14 to August 7, Inclusive	523
<i>Private Radiophone Communication</i>	367	*Supplying Broadcasts Like Gas or Electricity (Grayson L. Kirk)	35
<i>Protecting Our Readers</i>	15	Sweden:	
*Protecting Your Invention (Roger Sherman Hoar)	136	<i>New Station for Sweden, A</i>	100
Putting Your Patent Across (Roger Sherman Hoar)	205		
<b>R</b> ADIO an Auto Accessory in Jolly Old England	364	<b>T</b> ABLET Dedicated to the Radio Congregation, A	332
*Radio Angling and Fisherman's Luck (H. F. Huse)	316	*Teaching School from a Broadcasting Station (Lloyd Jacquet)	331
Radio As a Rent Inducement (Allison Euray)	22	<i>Telephone Company's Part in This Work, The</i>	448
<i>Radio Blind Spot, A</i>	454	*10,000 Miles of Radio Lectures in China (C. H. Robertson)	382
*Radio Broadcast Central (Pierre Boucheron)	254		
*Radio Code with Eleven Million Variations, A (S. R. Winters)	62		
*R. F. Amplification Without Distortion or Reradiation (Edward Lindley Bowles)	214		
*Radio in Summer Camps (Elon Jessup)	102		
*Radio Is Expensive for the Married Man (Robert Oliver)	202		





INDEX—Continued

	PAGE		PAGE
*Squire, Frank M. ....	361	Horine, E. E. ....	74,247
Stralia, Elsa ....	461	Huse, H. F. ....	316
*Strohm, Christian .....	11		
Taylor, Mildred .....	229	Jacquet, Lloyd .....	331
Taylor, Peter .....	229	Jasperson, R. O. ....	20
*Thomson, Basil .....	93	Jenkins, J. Elliott .....	411
*Thomson, Joseph .....	183	Jessup, Elon .....	102
		Jones, Frank H. ....	368
Walska, Ganna .....	135	King, Arthur N. ....	210
Wheeler, Wayne B. ....	178	Kirk, Grayson L. ....	35
White, Abbye M. ....	421		
White, W. C. ....	442	Levin, Claude Cathcart .....	159
Woodruff, George .....	490	Lynch, Arthur H. ....	251
		McDonald, E. F. Jr. ....	500
Young, Owen D. ....	246	McLeary, F. Burnham .....	282
		M., J. H. ....	3,91,179,269,359,447
		Munzig, Arthur L. ....	476
		N., J. T. ....	219
		Nelem, Frank .....	480
		Oliver, Robert .....	202
		Plough, Alvin Richard .....	323
		Polson, Alex. V. ....	288
		Procter, Frederic W. ....	29
		Reith, L. ....	486
		Roberts, Quincy F. ....	471
		Roberts, Walter VanB. ....	16,108,340
		Robertson, C. H. ....	382
		Rodgers, W. W. ....	118,397
		Rothafel, S. L. ....	458
		Shalkhauser, Eric G. ....	417
		Simpson, J. L. ....	299
		Sleeper, M. B. ....	404
		Smith, Leland L. ....	42
		Standiford, W. S. ....	161
		Stark, Kimball H. ....	38
		Weaver, Roger A. ....	346
		White, Abbye M. ....	421
		White, W. C. ....	375
		Whitefield, Charles T. ....	133
		Wilson, Willard .....	112
		Winters, S. R. ....	62
		Witherby, Lester .....	236

AUTHORS

Bartholomew, Richard .....	304
Blumenfeld, H. ....	426
Boscow, A. R. ....	325
Boucheron, Pierre .....	254,494
Bouck, Zeh. ....	23,230,319,391,496
Bowles, Edward Lindley .....	123,214
Bradley, J. Townsend .....	146
Burghard, George E. ....	290
Caddell, Alfred M. ....	128,406
Cardwell, Allen D. ....	430,511
Carter, M. G. ....	311
Clark, A. G. ....	28
Crouse, George B. ....	142
Dellinger, J. H. ....	241
Denning, J. W. ....	484
Dill, Herbert E. ....	314
Dreher, Carl .....	190
Euray, Allison. ....	22
Godley, Paul F. ....	154
Grimes, David H. ....	197
Harrington, E. D. ....	234
Harris, William Jr. ....	114,465
Henry, A. ....	67,149,222,336
Herts, Jacques H. ....	52
Hoar, Roger Sherman .....	55,136,205





Revised List of Broadcasting Stations

# RADIO BROADCAST

May, 1923

v. 3 #1

The "Brief-Case" Single-Tube Loop Set

Why Life is Interesting to a  
Commercial Operator

The "Neutrodyne" Receiving System

Dry Cells and WD-11's

Transmitting and Receiving with  
the Same One-Tube Set

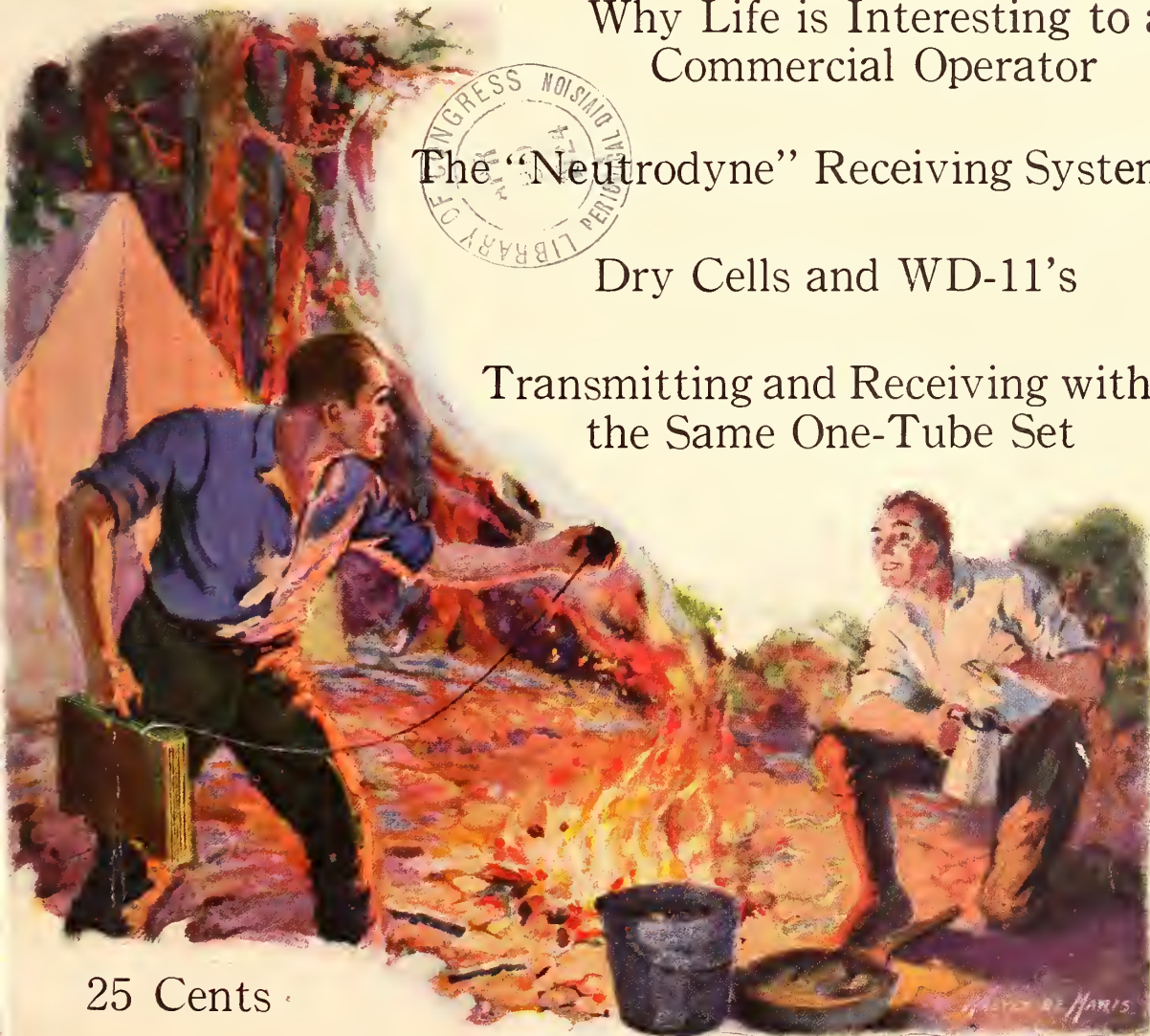

25 Cents



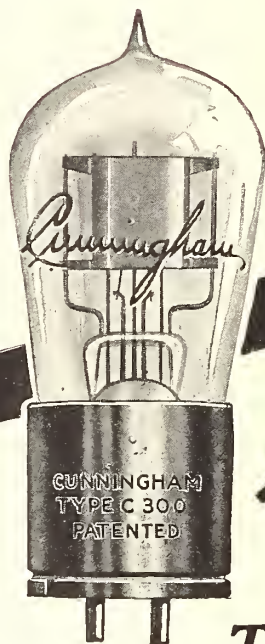

# Cunningham

## Tubes for Every Requirement



Vacuum tubes are used for two distinct individual purposes in a receiving set—as DETECTORS and as AMPLIFIERS. The qualifications of a tube for these two uses are so different that for maximum efficiency tubes of entirely different design must be used.

This point was one of the chief considerations of the research engineers who designed Cunningham tubes in the great laboratories of the General Electric Company. After years of research and experimental work, the Cunningham C-300, a SUPER-SENSITIVE DETECTOR, the Cunningham C-301, a DISTORTIONLESS AMPLIFIER, and the Cunningham C-301A, a LOW FILAMENT CURRENT AMPLIFIER, were developed. These three tubes, now nationally recognized as standards for all types of receiving sets, are responsible for the highly perfected results obtainable in radio phone reception.



The trade mark GE is the guarantee of these quality tubes. Each tube is built to most rigid specifications.

**TYPE C-300**  
Super-Sensitive  
**DETECTOR**  
**\$500**

**TYPE C-301A**  
 $\frac{1}{4}$  Amp. Fil-Current  
Amplifier and Detector  
**\$650**

**Patent Notice**—Cunningham tubes are covered by patents dated 11-7-05, 1-15-07, 2-18-08, and others issued and pending. Licensed for amateur, experimental, and entertainment use in radio communication. Any other use will be an infringement.

*Home Office:*  
248 First Street  
San Francisco, Calif.

*Eastern Representative:*  
154 West Lake St., Chicago, Illinois

★ Tested and approved by RADIO BROADCAST ★



# Radio Broadcast

ARTHUR H. LYNCH, EDITOR



## CONTENTS FOR MAY, 1923

<i>Herbert C. Hoover, Secretary of Commerce</i> - - - - -	<i>Frontispiece</i>
THE MARCH OF RADIO - - - - -	3
A SINGLE-TUBE LOOP SET IN A BRIEF-CASE - - - - -	WALTER VAN B. ROBERTS 16
CONFESSIONS OF AN UNMADE MAN - - - - -	R. O. JASPERSON 20
Drawings by Thomas E. Monroe	
RADIO AS A RENT INDUCEMENT - - - - -	ALLISON EURAY 22
THE "HAM" SET OF AN OLD SHIP OPERATOR - - - - -	ZEH BOUCK 23
THE TUNING TROUBLES OF MESSRS. GALLAGHER AND SHEAN - - - - -	A. G. CLARK 28
TRANSMITTING AND RECEIVING WITH THE SAME ONE-TUBE SET	FREDERIC W. PROCTER 29
HAVE YOU HEARD THESE STATIONS YET? - - - - -	33
SUPPLYING BROADCASTING LIKE GAS OR ELECTRICITY - - - - -	GRAYSON L. KIRK 35
THE "NEUTRODYNE" RECEIVING SYSTEM - - - - -	KIMBALL H. STARK 38
AN S O S IN THE JUNGLE OF INDO-CHINA - - - - -	LELAND L. SMITH 42
ADDING TWO STEPS TO YOUR AERIOLA SENIOR - - - - -	JACQUES H. HERTS 52
WHAT CAN BE PATENTED? - - - - -	ROGER SHERMAN HOAR 55
Drawings by Thomas E. Monroe	
LISTENING TO A BROADCAST PROGRAM AT HOTEL BELLEVUE, SAN FRANCISCO	60
A RADIO CODE WITH ELEVEN MILLION VARIATIONS - - - - -	S. R. WINTERS 62
AMONG THE "HAMS" - - - - -	64
ALL BOY SCOUTS, ATTENTION! - - - - -	66
WHY LIFE IS INTERESTING TO A COMMERCIAL OPERATOR - - - - -	A. HENRY 67
THE BROADCAST RECEIVING CONTEST—RULES AND PRIZES - - - - -	73
SIX-INCH DRY CELLS AND WD-11 TUBES - - - - -	E. E. HORINE 74
REVISED LIST OF ALL U. S. AND CANADIAN BROADCASTING STATIONS - - - - -	78
THE GRID—QUESTIONS AND ANSWERS - - - - -	79
NEW EQUIPMENT - - - - -	88

Copyright, 1923, by Doubleday, Page & Co. All rights reserved  
TERMS: \$3.00 a year; single copies 25 cents

F. N. DOUBLEDAY, Pres.  
RUSSELL DOUBLEDAY, Sec'y.

ARTHUR W. PAGE, Vice-Pres.  
S. A. EVERITT, Treas.

NELSON DOUBLEDAY, Vice-Pres.  
JOHN J. HESSIAN, Asst. Treas.

## DOUBLEDAY, PAGE & CO.

THE WORLD'S WORK  
EDUCATIONAL REVIEW

COUNTRY LIFE

THE GARDEN MAGAZINE  
HEALTH BUILDER

SHORT STORIES

CHICAGO: People's Gas Bldg.

GARDEN CITY, N. Y.

NEW YORK: 120 W. 32nd Street

BOSTON: Tremont Bldg.

LOS ANGELES: Van Nuys Bldg.





# Exide<sup>★</sup>

## BATTERIES

### Uniform current cuts out the noise

**E**VERY radio amateur knows how disastrous battery noises are to clear receiving. You can avoid this annoying interference by getting the battery that insures a steady flow of filament current. That battery is the Exide Radio Battery.

This specially designed radio battery does its work uncomplainingly, and never requires much attention. The rasping, snarling noises often caused by fluctuating current in ordinary batteries do not exist in the Exide Battery. It delivers uniform filament current for every type of vacuum tube. You can count on the Exide for dependable, long-lasting service.

Exide Batteries are used in a majority of the government and commercial wireless stations and in every industry where a battery's response to the call of duty must not fail.

Any dealer in radio equipment will sell you an Exide Radio Battery, or you can get one at the nearest Exide Service Station.

**THE ELECTRIC STORAGE BATTERY CO.**  
Philadelphia, Pa.

Service Stations Everywhere

Branches in Seventeen Cities



★ Tested and approved by RADIO BROADCAST ★



© Paul Thompson

HERBERT C. HOOVER, SECRETARY OF COMMERCE

The White Radio Bill failed at the last session of Congress, but the radio world is now looking to Secretary Hoover to make the best of a bad situation by regulating wavelengths in so far as his present authority allows



# RADIO BROADCAST

Vol. 3 No. 1



May, 1923

## The March of Radio

WHAT RADIO BROADCAST IS TRYING TO DO

**T**HIS is our first anniversary number. The twelve issues of RADIO BROADCAST which have preceded this represent twelve efforts to give you the very best magazine we could make.

It is evident that no uncertain policy, no wavering of ideals, and no subordination to any selfish interest can lead to the highest usefulness of this or any other publication. We believe that you will be interested in a brief statement, at this time, of just what we stand for, what we have been trying to do, and what interests RADIO BROADCAST will continue to serve. We believe:

That the most important function of radio is to make life safe at sea;

That closer and more friendly relations between the United States and other nations can and should be fostered by means of radio communication;

That in broadcasting we have a tremendous force which, properly directed, may be a means of incalculable and universal good; and that every effort should be made to see that this force is fairly and intelligently used for the benefit of the greatest number.

It is our intention to continue a policy which is consistent with these beliefs. First, last, and always, we are for "Better Radio." We make mistakes, but believe that those who do not make mistakes, never make anything. Although you may not always agree with the ideas we express, you can always be sure that we believe what we say and that we make every effort to state the facts clearly and justly.

Much of our present radio development is directly traceable to that group of electrical experts whom we call, for lack of a better name, "amateurs." There are those who would terminate the activities of these experimenters, but in our opinion such a procedure would be not only unjust, it would be folly, for certain of the amateurs' activities are conducive to great benefits to radio.

Concerning broadcasting, this phase of our game is at once the most interesting and popular. Broadcasting has done more to advance radio in the last two or three years than all the efforts of previous years. Of course, there is much to be desired in broadcasting as we find it to-day. We need improved transmission, better programmes, adequate wavelength regulation, fewer high-power broadcasting stations, a more satisfactory distribution of transmitting stations, a reasonable standardization of apparatus.

We have consistently endeavored to promote regulation of a helpful character. As you know, you and we have campaigned together for legislation designed to bring about the changes necessary for better broadcasting.

Thus, you will see that RADIO BROADCAST is, in a sense, not our magazine—it is *yours*. We are but players on a stage, interpreting to the best of our ability for you, our audience, without whom there would be no play.





## As the Radio Corporation Sees the Patent Situation

THE following letter from General Harbord, President of the Radio Corporation of America, sets forth the Corporation's views on the radio patent situation. In an editorial in our March issue we called attention to the possible harmful results of what seemed like a tendency on the part of the Corporation toward a monopoly in the production and sale of radio apparatus. Last month, we published an article entitled "Coöperative Competition", which showed how automobile manufacturers found a way out of a situation which seems to us similar in some respects to that now facing the radio industry.

We are glad to publish General Harbord's letter, and we should be glad to publish letters from the companies on the other side of the controversy, for this is perhaps the most important question in the radio field and one on which all radio enthusiasts should have information—and tolerance.

RADIO CORPORATION OF AMERICA,  
233 Broadway, New York.  
Office of the President

MR. ARTHUR LYNCH,  
EDITOR, RADIO BROADCAST.  
MY DEAR MR. LYNCH:

I regret that absence from the City has prevented me from complying with your request transmitted to me by Mr. Stuart Crocker for a statement regarding the plans of the Radio Corporation with reference to the radio patents held by it. I think you will appreciate that it is impracticable in a new art such as radio to make a statement which shall at the same time be prophetic and accurate. Such a statement can only be based on present actual knowledge. It might at any time call for a restatement because of change of conditions. For the present, the best that any company in the radio industry can do is to make month to month decisions.

If I may be permitted a word as to the purposes of the Radio Corporation, I would say that it was organized under the laws of the country for operating a lawful enterprise, for the same object which prompts the launching of any other business institution—service to the public with the hope of a fair return to the stockholders. In addition to this legitimate ambition for material success, the corporation has striven to be of service in a technical and patriotic way. It has aided in the development of radio art, and has furnished the first American owned and controlled means of direct commercial telegraph

communication with the principal foreign countries, making the United States the great centre and leading factor in world radio communication. To achieve these ends it has been obliged to coördinate the inventive genius of many individuals. It has made great outlay for research and development work in perfecting its own inventions, and to advance the radio art it has also been considered wise to acquire the inventions of others. In no other way could the various improvements and best features of the numerous inventions—no one of them adequate in itself—which are regarded as requisite to satisfactory radio service, have been assembled and made available for the public in any one line of apparatus. Had the several inventors joined forces, the situation would have been the same under some other organization bearing a different title.

Thus far, the public and a few manufacturers and dealers—some legitimate, but many of them infringers—have profited from the development and production of radio apparatus. The stockholders of this corporation whose money and faith in the patent laws have contributed to the technical achievements largely responsible for progress made have not yet drawn a dollar in profits.

There have been some criticism against the Radio Corporation for bringing suit against various radio manufacturers for the infringement of patents. The cry of monopoly and the charge of oppression of small manufacturers are easily raised, and usually by those to whom the propriety of great exactness of speech does not appeal.

The Radio Corporation had the absolute right to enforce every patent which it owned against every user. It did not, however, adopt this policy, but instead, in keeping with the high ideals which have characterized it since its inception, decided that if an amateur wanted to build his own set for his own amateur use he could do so, and that it would not, until further notice, treat such procedure as an infringement of its patent rights. But there is absolutely no reason why the Radio Corporation, which ought to clear this property represented by important patents, and which shares are now owned by over 33,000 stockholders, should allow this property and patents to be recklessly trespassed upon by hundreds of rival manufacturing companies, most of which make no contribution whatever to the art, have made no investment in property patent rights, and merely attempt to reap where others have sown. The Radio Corporation is therefore proceeding to enforce some of its rights by the normal orderly process of suit in the Federal Courts. It is not attempting to create a monopoly; it is attempting to enforce the lawful rights limited in scope and in time which it has been necessary for it to acquire in order that the radio art might go forward. It is as important to the entire radio industry to have these patents judicially



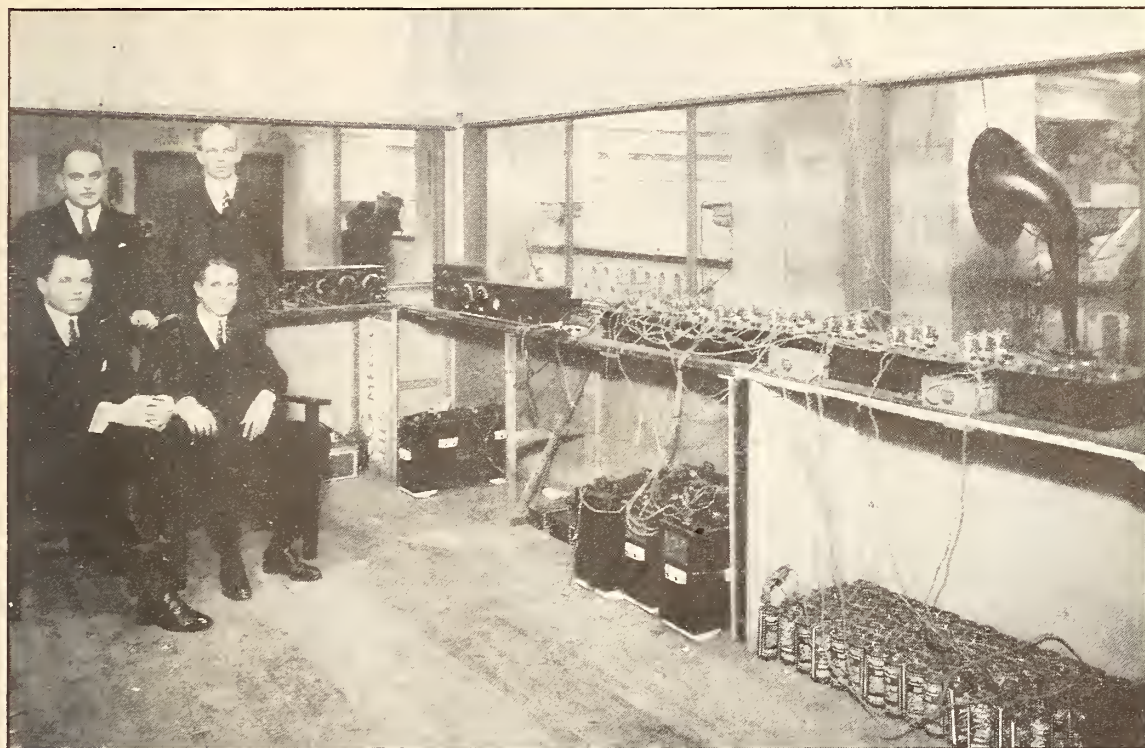

#### ARMSTRONG'S SUPER-HETERODYNE

In a glorified form, it was one of the features of the radio exposition held in New York. Western Electric loud speakers, each operated from its own power amplifier, were placed in various points in the Grand Central Palace. The plate voltage was supplied by a great number of standard 6-inch dry cells, and about thirty-six vacuum tubes were used. Radio engineers predicted failure for this outfit, which was installed and operated by the Radio Club of America with complete success. Left to right, in the picture, are: L. S. Byers of the Exposition Company; Louis G. Pacent, chairman of the Committee on Papers; George Burghard, President; and Edwin H. Armstrong, Past President of the Radio Club

tested as it is to the Radio Corporation. Not until its validity has been judicially determined is it possible to evaluate the proper royalty basis for a patent. Until this is done, there will be continual confusion, and the radio patent situation in the United States will remain unprofitable to inventors and unsound as far as manufacturers are concerned. We, therefore, have instituted suitable action to reach sound conclusions. We go so far as to believe that all holders of radio patents should do the same thing, if this present complex and disturbing situation is to be clarified.

An infringer of patents has the advantage that he has no patent investment, no research to finance, no responsibility to the art. He can make a thing and sell it; if he makes a dollar profit it belongs to him until the Courts take it away from him, which can only happen after a long litigation. The great concern which has made all this development possible, which has spent millions in clearing the road for American radio has to earn something on what it spent in acquiring that pathway. Enforcement of its patent rights with the Federal Courts will help it to earn that something. If its rights are not as broad as it believes them to be the Courts will say so.

In its efforts to test its rights and find out just what they really are and to enforce them the Radio Corporation should have the sympathy of everyone who really wishes the good of the radio art; for if such rights acquired under such circumstances and at such cost are not sustained and enforced, who again will feel justified in taking the risks and making the expenditures that were taken and made when the Radio Corporation was formed?

We must have it clear in our minds that a patent under the constitutional laws of the United States grants to the inventor or to the person to whom he has assigned the patent, the exclusive right of its use. This means that with perfect legality and due regard for the ethics of the situation, the Radio Corporation has such exclusive right to its property in patents. Any one not in agreement with this disagrees with the Constitution of the United States and the laws passed in conformity with it having for a purpose the establishing of patent privileges to inventors and owners of patents.

There has been a suggestion for a coöperative pooling of radio patents in order that all companies can manufacture radio apparatus without fear of patent difficulties. According to the best of my in-





A PRICELESS BOON

To an ordinarily active person who is forced by accident or illness to pass many long hours of inactivity, a broadcast receiving set is a blessing. William Snider, repairman for the Bell Telephone Company, broke both arms and legs in a fall from a pole recently, in Canton, Ohio. Friends among his fellow workers conceived the idea that a radio set might help to pass the tedious hours. Accordingly, a receiver was installed, and the patient was able to keep in touch with the world beyond his hospital window, hearing the concerts every afternoon and evening.

formation, no coöperative pooling of patents in any industry has ever been effective until this initial stage has been passed. The pooling arrangement does not take place during the nebulous period under which the developed art passes. Future inventions and developments will probably very greatly change the radio art as we know it to-day.

The future policy of the Radio Corporation regarding patents cannot be more definitely stated at this time. I am glad to give assurance, however, that we intend to be as helpful to the rapid advancement of the radio art as it is within our power to be. The United States should be proud of its position in the development of radio throughout the world. It is with the avowed purpose of maintaining this position that the corporation will always approach the solution of radio problems.

By coincidence, the laws under which we claim our rights are based on the same provision of the United States Constitution which protects your employers in the publishing business, namely, Clause 8 of Article 1. If you should write a scientific work as a result of your years of labor and study, and bring it out at great expense, would you think it a crime or injustice to others who were endeavoring to steal your work that they should be enjoined from doing

so for a limited period granted you in which to realize some legitimate profit from your work? That is a similar question to the one which has to be decided by the officers of this corporation, representing over 33,000 stockholders whose motives are impugned by statements in an editorial appearing in the March issue of Radio Broadcast.

I am sure that with this frank statement I can confide in your fairness to the Radio Corporation in the future.

Sincerely yours,

*J. S. Harbord*

### The Effect of Broadcasting on Sermons and Speeches

THE pioneer radio preacher of Pittsburgh, the Rev. Dr. E. J. Van Etten of Calvary Protestant Episcopal Church, gave his opinion recently on the effect which radio might be expected to have on church services. He has probably thought along these lines as much or more than any other churchman,



and has had enough experience in the matter to have reached some interesting conclusions.

We cannot doubt that the radio church service is here to stay, just as is the concert and opera. What will be the effect on the churches themselves of thus spreading their service over a large territory with possibly thousands of listeners? Such an innovation cannot be introduced without having some reaction on the man conducting the service. Some of the churches have a perfectly fixed service routine so that no changes in this respect can be expected; the flexible feature of any church service is the sermon, and the preacher of the sermon. The ritualistic churchman will assert that the personality and ability of the preacher have little to do with the value of a church service, but to the average church-goer the preacher is of paramount importance. Many people go to church "to hear Dr. So-and-So."

Doctor Van Etten, in a recent sermon on this question, said that in his opinion "broadcasting of church services will prove something of a disintegrating force on the church organizations

themselves. Only the fittest preachers will survive, and struggling churches will, more or less, go to the wall." This seems like a very sensible conclusion—a preacher of mediocre caliber can hold his congregation only so long as other and more inspiring men are not available. When the congregation can stay at home and hear the wonderful musical service from a metropolitan church, and listen to the words of a superior mind, the small country church with its itinerant pastor is quite likely to suffer.

In his sermon, Doctor Van Etten further stated that "radio religion is not a substitute for public worship. It must become active and not passive." This brings up the question of the effect of radio broadcasting upon church attendance; will many people be content to take their religion from the loud speaker? If we can accept the explanation of the large crowds at the Manhattan Opera House recently, the attendance at church will increase rather than decrease as a result of broadcasting, that is if the service is carried out in an appealing and inspiring manner and if the preacher shows



GATHERING WEATHER REPORTS AT A POWERFUL GERMAN STATION

The reports received from Paris, Warsaw, Christiania, London, and other cities are used to make up the daily forecasts broadcasted from this radio telegraph station located in Berlin



ability and sincerity in his words. In fact, this condition has already been observed following the weekly broadcasting of the Men's Conference at the Bedford Y. M. C. A. in Brooklyn, N. Y.

This idea of forcing the preachers to improve the quality of their sermons leads us to a suggestion for many of our celebrated after-dinner speakers. They don't realize it, of course, but the radio audience is composed of nearly the same individuals every evening, even though those listeners directly in front of them may be different. The professional after-dinner artist has been able to earn his meal ticket rather easily in the past; one set of stories might go for the whole season if he was careful concerning the invitations he accepted. But not so now. We recently heard one of our national figures tell the same stories on three different occasions, all within a week. It's well that he didn't know how many of us had already heard

about the marriage of his chauffeur, as it would have taken all the fun out of his narration. It's interesting to know also that some speakers have had to change somewhat the quality of their stories, for they never know who is going to hear them.

### The Sunrise and Sunset Barrier to Signals

EVERY careful observer has noticed that the distant stations seem to be erratic in the way they "come in." Some evenings the signal received may be consistently strong, and on others it may fluctuate greatly in strength even during the course of an hour or less.

According to one of our correspondents, certain stations show this fading phenomenon with a remarkable degree of regularity; his observations, which he has sent us, show a striking resemblance to those of Marconi when



© Underwood & Underwood

### NOTHING LIKE THIS WHEN HE TROD THE QUARTERDECK

England's oldest seadog, the Hon. Sir Edmund Robert Fremantle, Rear Admiral of the United Kingdom since 1901, recently listened to a concert broadcasted from the Eiffel Tower, in the cabin of his old ship, H. M. S. *Impregnable*. Admiral Fremantle entered the Navy in 1849, in the real days of "ships of oak and men of steel," when muzzle-loading cannon lined the decks of tall-masted frigates



that pioneer was first trying to bridge the Atlantic. As any student of radio knows, Marconi found it almost impossible to send his signals across the sunset or sunrise line. When the sun was up in Ireland and not yet up in Newfoundland, the sunrise line was between the two stations and this line seemed to act as a kind of check to the electric waves. The signals acted the same way when the sun had set in Ireland and had not yet set in Newfoundland. This effect is not noticed to any great extent by the long-wave, high-powered stations used for transatlantic service to-day, but with Marconi's shorter-wave, lower-power stations it was a very important factor. The fading of signals noted above is probably similar in nature to the troubles encountered by Marconi.

When two stations are broadcasting with carrier waves within a meter or less of one another they produce a constant singing note in the receiving set, even when this set is not oscillating. (With the rapid increase in number of broadcasting stations this beat note interference becomes very much of a nuisance when reception from distant stations is being attempted.) Our correspondent, who lives about one hundred miles from New York, on listening to the beat note between a New York station and a Chicago station, reports the note just audible when the sun is up in New York City; as soon as the sun sets at his station he observes that the beat note at once increases several times in intensity and that about an hour later, when the sun is setting in Chicago, a remarkable increase in signal strength occurs, the increase not being gradual but occurring very suddenly. This action is so regular, he reports, that he can tell within a minute or two when the sun sets in Chicago!

Several very capable experimenters have been engaged during the past year in making a continuous record of signal strengths from those stations which seem to fade most regularly and we may expect their work soon to give us some reliable data on the fading phenomena.

#### Transmitting Standard Wavelengths for Calibrating Sets

THE scheme of transmitting standard wavelengths from the Bureau of Standards, which we suggested as possible and advisable in our last issue, has already been inaugurated. The first standard signals

were transmitted on March 6th from 11.00 P. M. to 1.15 A. M., this time having been chosen because it was freer from interference than the early part of the evening. Every twenty minutes during this period the wavelength was changed so that, during the two hours, seven standard wavelengths, from 550 meters to 1500 meters, were transmitted. Preliminary tests carried out on January 31st showed the feasibility of the scheme and also convinced the Bureau that it was worth while.

Much of the work of the radio department of the Bureau has to do with calibration of condensers, coils, and wavemeters. These instruments have to be shipped by the owner to the Bureau, tested, and then shipped back; not only is this an unnecessarily expensive procedure but it has been in the past extremely unsatisfactory, as the handling of the instrument by the express employees, subsequent to its calibration, and before the owner received it, many times subjected it to jarring sufficient to make the certification of the Bureau at least doubtful—and that is really as good as no certification at all.

Not only must laboratories have accurate calibration of their apparatus, but every intelligent radio listener would like to have his receiving set calibrated for wavelength, so that, instead of "feeling around" for the signal of a certain station he could at once adjust his set to the wavelength on which the desired station was to transmit and if no signal was heard he would conclude that the station was not on the air. Hence, the average listener welcomed the news that standard wavelengths were being transmitted and hoped that they would soon include the broadcast range.

The calibration signals sent out by the Bureau are continuous-wave signals and can be received only by the heterodyne principle; the local receiver must be made to oscillate by a tickler coil or other means, and the Bureau's call will give the characteristic whistling note signal. By adjusting the receiving set to make the beat note have zero frequency, a point on the variable condenser is obtained, which tunes the set to exactly the frequency the Bureau is broadcasting; this setting is extremely accurate and the set may be calibrated to a fraction of a meter if its construction has been sufficiently well carried out. The tickler coil coupling should be as loose as is possible and still maintain oscillations, otherwise its adjustment will



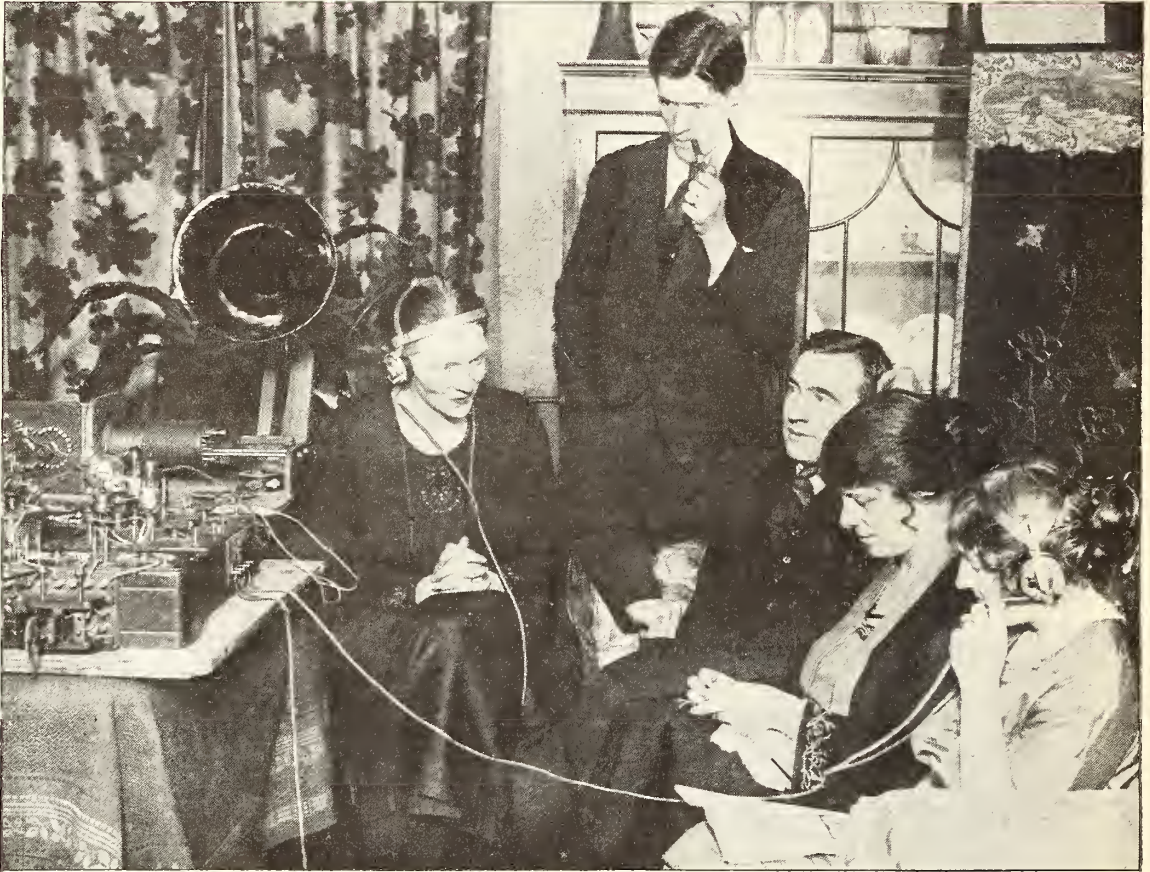

© Underwood &amp; Underwood

#### LISTENING TO THE GOVERNMENT BROADCAST IN AN ENGLISH HOME

The English experimenter has been going through a stage of development in radio construction familiar to all "old-timers" in this country: working units of all sorts and sizes are placed on a board and wired up regardless of compactness, appearance, and simplicity of operation. The Englishman has done some excellent work in constructing his own equipment, however, and some of the commercial companies produce apparatus that would be hard to beat anywhere

make the calibration of the receiving set less accurate.

As this goes to press, we learn that about April 1st another set of signals, from 300 to 600 meters, is to be broadcasted, and about May 1st another set of from 125 to 300 meters will be sent out. These tests will be repeated periodically so that checks on the accuracy of apparatus many frequently be made.

Considering the small staff engaged in radio work at the Bureau of Standards, and the importance of work like that mentioned above, we have sometimes questioned the judgment shown as to what problems should be studied by the Bureau. The circulars recently issued on the testing of receiving sets, and that on the specifications for dry cells, are, in our opinion, illustrations of work which the Bureau should not attempt; there is so much work of more

importance to be done. We believe this broadcasting of standard waves is one of the best services the Bureau has yet done for the radio public, and we expect that the accuracy of the signals will warrant the faith we shall put in them.

#### Boosting the Box-Office Receipts at the Opera

THE following article, which appeared in the *New York Times* for February 20th, provides an interesting field for speculation as to the coming relations between opera in the opera-house and opera via radio—at home:

RADIO "FANS," DRAWN TO GERMAN OPERA, RECALL THE CROWDS OF HAMMERSTEIN DAYS

Without warning save for such explanations as followed the Manhattan's first "broadcasting" of an opera here two



nights previously, the former Hammerstein Theatre in Thirty-fourth Street was besieged by opera-goers all day yesterday and its lobbies were the scene of a wild but friendly "riot" last night when the Wagnerian Opera Festival began its second week with a packed house for "Die Meistersinger." At first the management was at a loss to account for the crowd, some hundreds of whom had to be turned away for lack of either seats or standing room.

Then it was suggested that the wide public interest had resulted from Saturday's experiment, when a performance of "The Flying Dutchman" had been sent by radio out to a city and suburban population of millions from the Westinghouse plant at Newark, N. J., the music having been conveyed to that place on a wire installed in the Manhattan stage by the Postal Telegraph Company. Influential members of the Metropolitan directorate had likewise heard it and there were those who said the result might change the policy of the older Broadway house, which hitherto had barred the broadcasting of opera by radio.

It would seem that even the Metropolitan Opera Company, with its ordinarily well-filled house, cannot afford to overlook the possibilities in the situation and we hope that the directors will soon reverse their decision not to permit the broadcasting of its performances.

For those of us whom distance and expense prevent from going to see the famous operas, now and then, such an announcement would be most welcome.

### What is the Range of a Broadcasting Station?

WE HEAR so much nowadays about the remarkable distances covered by broadcasting stations that one may reasonably suppose that the audience of one of the better class stations often numbers tens of thousands. Practically any quiet evening we can hear stations a thousand miles away and we are informed by the National Radio Chamber of Commerce that there are between one and two million receiving sets in the country. Figuring only two or three listeners to a set gives a total radio audience of about five million. If, then, reception over a thousand miles is reasonable, an audience of



LISTENING TO AN OPERA HE HEARD IN 1859

Christian Strohm traveled from Oldes Leben to Weimar, Germany, sixty-four years ago to hear the first presentation of an opera composed by Wagner. This year, he heard on a crystal set the same music, broadcasted from WIP, Philadelphia

a million is not at all impossible, however improbable it may be.

But how many people actually do hear stations one thousand miles away consistently? One of our friends, living in New York City, who has recently bought a modern receiver, confided in us that although he had a set with detector and two steps of audio-frequency amplification, he had never heard stations farther away than Newark, twenty miles distant. He probably isn't the only one who has trouble hearing stations a thousand miles away. The fellows who do hear distant stations do a lot of talking about it but those who have received only within a fifty-mile radius keep quiet when distant records are being discussed.

As a matter of fact, to many listeners-in, there is no particular fascination in spending half the night bringing in the call letters of some distant station, whose programme may be mediocre, when at the same time, a good local station is providing excellent entertainment. Nevertheless, it would be interesting to most of us—whether or not we collect call letters the way some zealots collect autographs or postage-stamps—if one of the popular stations, which has received the thousands of letters which we hear about from the announcers, would plot on a map, for publication, the location of each of these listeners who write in, and so let us know the average distance of the radio audience. We predict it would be well within the thousand-mile limit, even taking into account the fact that the long-distance listeners would be the more likely to write. It would be illuminating to have on record not the number of the *possible* radio audience, but the *actual* number of the audience listening, on a particular evening, to any particular programme.

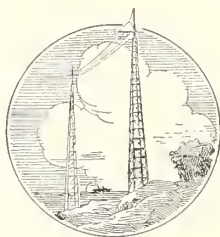

### Atchison, Kansas, Takes Control of Radio

**K**ANSAS is always "doing things," so we are not surprised to hear of a municipal regulation concerning radio, enacted by the commissioners of the city of Atchison. The good people of Atchison evidently need some special supervision, as we are informed that "three hundred aërials were ordered down by the chief engineer of the local lighting company." It seems that the lighting company's poles were being used to hold up the aërials, in spite of the fact that these same poles carried

a powerful current at 2300 volts, and 1750 volts is as high as is used in Sing Sing to kill the condemned.

The ordinance passed by the commissioners has to do with the disturbing influence of small boys with spark transmitters. So it was "hereby made unlawful for anybody unnecessarily and electrically to disturb the atmosphere within the city limits of the city of Atchison by any means whatsoever not necessarily incident to the operation of some device, mechanism, or apparatus used and useful in any business, trade, or occupation." Fines and imprisonment are offered to disturbers of the atmosphere.

The city fathers have our approbation and well wishes in their attempt to clear the air of spark sets, but we judge they might have some trouble in sending the offender to jail if he didn't go willingly; a shrewd attorney might show the city was trying to usurp the powers of the Federal Government in the matter; if a certain small boy happened to have a federal license to operate his station we judge he needn't go to prison, no matter how drastic might be the municipal sentence imposed. We have heard of the federal authorities assuming control where the state or municipal machinery had broken down but it seems incongruous to have a small town stepping in to take care of the federal authorities' business.

Along this same line we have received some clippings from the *Daily Record* of Kitchener, Ontario, which indicate that our Canadian cousins also can act in radio matters with impetuosity and rashness. While we cannot condone illegal acts, we do sympathize with the Canadians in the situation which preceded their attack. It seems that several amateurs with spark sets had been disturbing the ether around Kitchener to such an extent that reception of distant concerts was apparently impossible for some of the listeners. After a period of controversy the antennas and poles of the offending stations were surreptitiously taken away in the night. Of course, if found the perpetrators may be prosecuted for property damage, as the law prescribes, but they are apparently not advertising their share in the exploit. As for the unfortunate station owners, they are by no means reconciled to their bereavement: to them the proverbial silence of the Sahara is as the noise of many waters compared to the reign of quiet around their spark transmitters.



## Will the Entire Nation Listen to the Next President's Inaugural Address ?

ONE of the latest developments in broadcasting was demonstrated before a large audience in many sections of the United States on the evening of February 14th. The event was one of the features of the annual convention of the American Institute of Electrical Engineers, held in New York City.

An audience of several hundred people in the Engineering Societies Building, in New York, and another similar audience in Kimball Hall, Chicago, were able to enjoy an illustrated lecture by the same speaker simultaneously. Both auditoriums were joined by a long-distance telephone line, at each end of which two complete "public address" systems were attached, permitting a speaker at either place to address the two audiences simultaneously, though he spoke in a comparatively low voice. Stereopticons and duplicate sets of slides were

provided and the audience at both ends of the line had no difficulty in following the entire lecture. A second lecture, delivered in Chicago, was heard in a similar manner in both cities. It gave the listeners an uncanny feeling to hear, at the end of the lecture, the applause of first one audience and then the other.

But even this wonderful demonstration of the practicability of joining audiences in various parts of our country by a two-way communication system was not enough to satisfy the American Telephone & Telegraph Company, who arranged it. An additional tap was taken off the wire connecting New York and Chicago and by a delicate manipulation of the circuits, enough current was drawn into the company's broadcasting station, WEAJ, in New York City, to actuate the modulating system at that station. In this manner, the listening audience became much larger than the visible audience. Enthusiastic reports from many parts of the country were received.

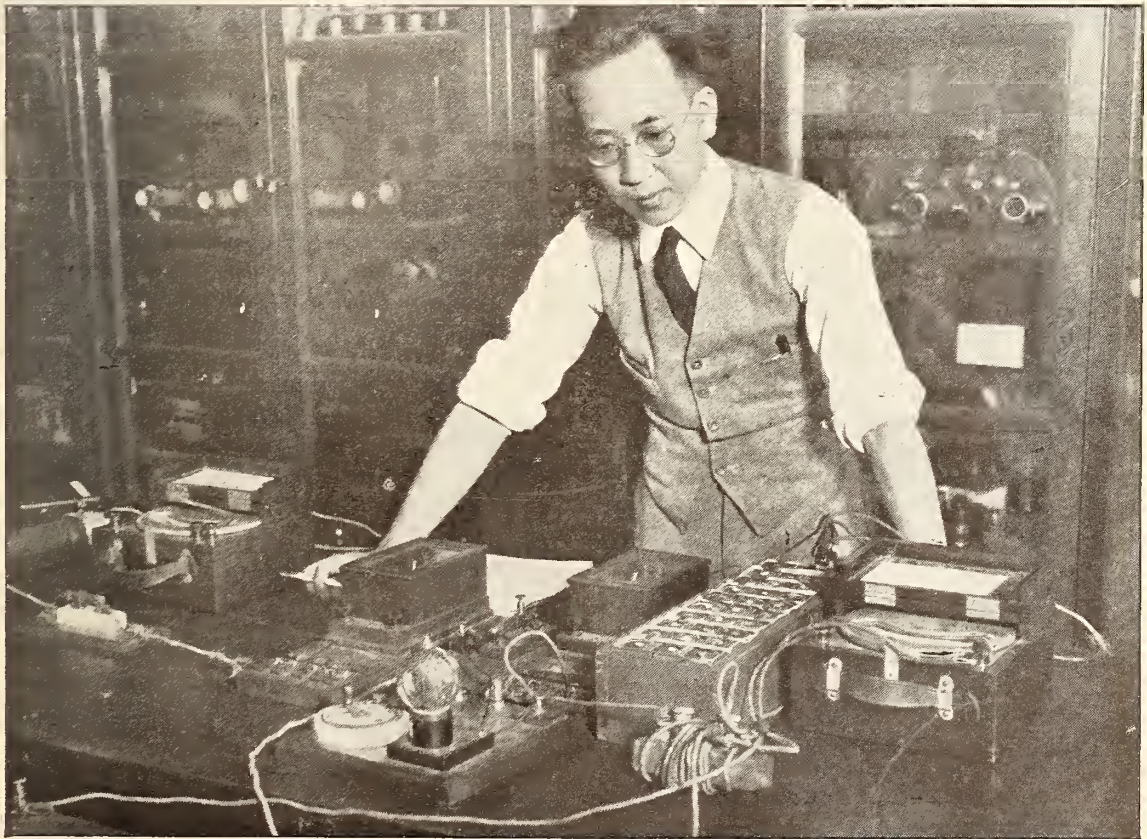

A CHINESE STUDENT DETERMINING TUBE CHARACTERISTICS AT COLUMBIA UNIVERSITY, N. Y. Mr. Shu S. Man, a graduate of Hong Kong University, came from China to do advanced research work in this country. He is here seen testing the amplification characteristics of a vacuum tube under various plate and grid voltages



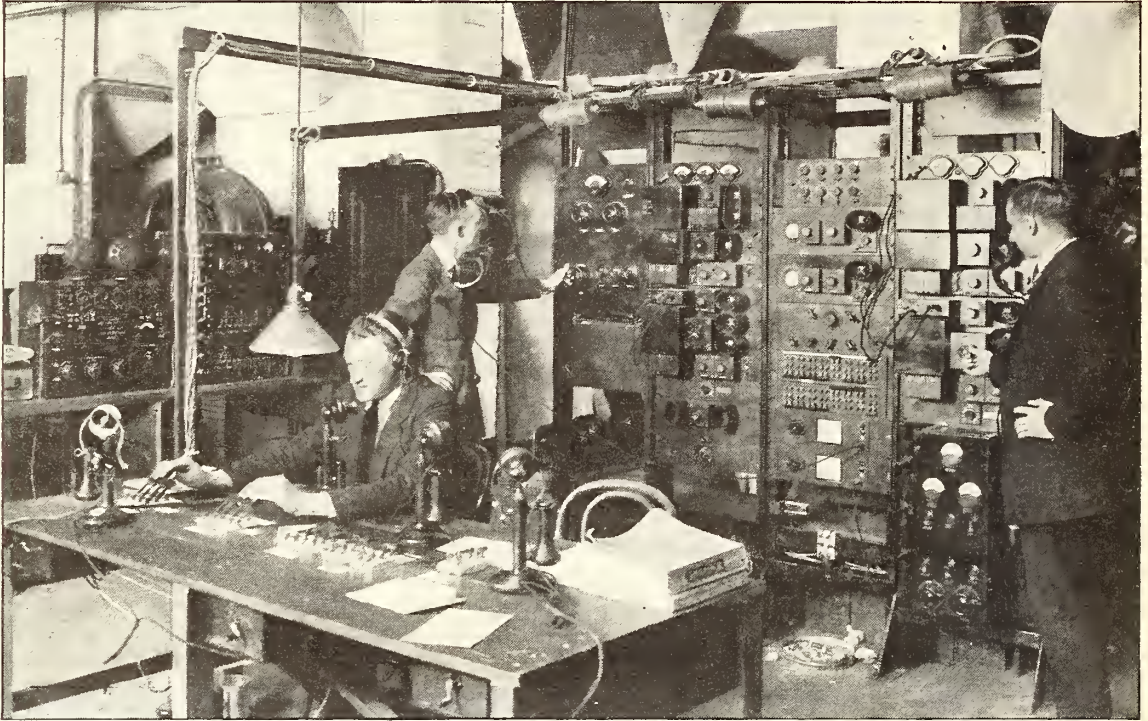

OPERATORS IN THE CONTROL ROOM

Located in the Engineering Societies Building, New York City, keeping the wires between New York and Chicago working at their best for the audiences, in both cities, some nine hundred miles apart

Picture to yourself a man in his living room in Chicago listening to a lecturer in his own city, the reproduction of the voice coming to him after a trip by wire to New York and by ether back to Chicago in less time than one's thoughts can follow the process. This will give you a slight idea of the possibilities of such a means of communication. It is quite likely that, for the first time in the history of our country, the next President's inaugural address will be heard in every state and most of the larger cities by a similar arrangement of telephone lines used in conjunction with broadcasting stations and receiving outfits equipped with loud speakers.

#### Twelve More Men Owe their Lives to Radio

**T**HE five-masted schooner *Santino* was recently put to the lowly task of carrying coal. She was built during the war when any respectable ship was at a premium, but in the after-the-war slump it was found that coal cargoes from Norfolk to New England were as much as she could hope to do. On her second trip from Norfolk in this work she

struck bad weather south of Nantucket Light and her seams opened up. The war work in the shipping yards apparently wasn't always very well done. To make her plight worse, her pumps broke down (the men who put them in were probably paid too much) and she was soon in a sinking condition. The twelve men who manned her were rescued with the help of radio; and the same signals which called the rescuing vessel called the Coast Guard cutter *Acushnet*, to salvage the vessel and her cargo or to destroy the wreck.

#### Radio Sets are Contraband in China

**I**T SEEMS that one political faction of China is afraid that radio may be too powerful a weapon in the hands of the opposition, and accordingly, broadcasting apparatus, such as we use here, has been put on the taboo list in China. An ambitious American firm announced that it intended to inaugurate a broadcasting service in China, but evidently changed its mind when the customs commissioner at Shanghai gave out the information that all such apparatus would be seized as contraband of war.



## ★ Protecting Our Readers ★

**D**URING the unprecedented demand for receiving apparatus—especially broadcast receivers—last year and again during the present peak of business, there has been, and there now is, a grand opportunity for unprincipled and uninformed petty capitalists to enter the radio business and, as they themselves express it, “make a clean-up.” Such a clean-up is usually accompanied by a large loss on the part of the victims, who, in the effort to purchase a radio outfit and finding all the standard lines depleted, are cajoled into purchasing what has come to be called “bootleg” merchandise.

Just as long as the world rolls on, we are going to find people in business who believe it is easier or preferable to earn their livelihood among the folks of whom Barnum said, “One is born every minute” than in legitimate enterprise. And there will ever be those gullible people who will part with their shekels to the tune of a suave talker’s eulogies on the merits of apparatus that proves to be practically worthless.

Our advertising department has adopted a plan which may save readers of RADIO BROADCAST from any such loss. This is the plan they have outlined:

We are to place a star in the advertising space of manufacturing companies whose material we know can be absolutely relied upon to do what is claimed for it. We are taking it upon ourselves to assure our readers that material purchased from advertising carrying our star is sold with the assurance that if its performance is not as represented in the advertising, it may be returned for credit. *Products of the best quality may be advertised without being starred, but this is only because they have not actually been tested by RADIO BROADCAST.* It goes without saying that advertisements of inferior products will find no place whatever in the magazine.

We cannot undertake a general endorsement of the merchandise handled by jobbing or mail order houses, although we are quite confident that our readers may look for fair dealing from any of those who advertise with us. In most instances the equipment handled by these houses, however, is already endorsed in the manufacturer’s own advertisements.

RADIO BROADCAST is the product of one of



AN ENGLISH INVESTIGATOR OF OUR BROADCASTING SITUATION

Mr. A. P. M. Fleming, C. B. E., England’s representative at the international convention of the Institute of Electrical Engineers at Niagara Falls said: “One of the things we have learned (from the experience of the United States) is to avoid the establishment of innumerable broadcasting stations with no plan of coöperation between them”

the largest publishing houses in the country—Doubleday, Page & Company. *Country Life*, *The World’s Work*, *The Garden Magazine*, *The Health Builder* and *Short Stories* are among the periodicals it publishes in its own plant at Garden City, N. Y. It is the largest publishing house in the radio magazine business, and is in a position to accept or refuse the advertising of any product which it believes to be unjustly represented.

Naturally, a plan of this nature is of great benefit to our advertisers, for it enables the readers of RADIO BROADCAST to buy with confidence. This, in turn, is helpful to our advertising department, for reputable concerns appreciate that being represented in a reliable periodical is a substantial asset to them. By the performance of this service, we are in a position to cement even more solidly the friendly feeling we already enjoy among our readers.

J. H. M.





results than expected with distant stations on favorable nights. The farthest stations heard so far from New York are Chicago, Kansas City and Davenport, Iowa. These are very faint, and although quite clear at times, are mentioned only to give an idea of the "freak" range of the set. Of course, as in the case of all unusually long-range reception, the "freak" part is the great distance that the waves travel sometimes without becoming too weak to detect. The receiver itself will not pick up any weaker signals at night than in the daytime; but longer distances are possible simply because the signals themselves are stronger.

In describing the operation of the circuit shown in Fig. 1, an understanding of the principle of super-regeneration will be assumed.\* The two features in which this circuit differs from the usual single-tube super-regenerator are the use of a plain Hartley interruption frequency circuit using only one large honeycomb coil, and the C battery so poled as to make the grid positive. When the tickler coil is moved away from the grid coil so that there is no tendency to oscillate at radio frequency, the grid and plate potentials will be approxi-



#### IT'S ALL HERE

Set, batteries, and phone are within the box ( $9\frac{1}{2} \times 13\frac{1}{2} \times 3$  inches). A 23-turn loop is wound around the outside

filament, while the grid potential varies about the C battery voltage between the grid and filament.

Now it can easily be shown by experiment that in a simple regenerative circuit using a small value of B battery, oscillations can be made to occur more readily if the value of the B battery is increased, while conversely, they start less readily if the plate potential (the B battery) is decreased. Another experiment shows that oscillations occur less readily if the potential of the grid is made positive (by putting in a C Battery) than if the grid potential is kept near zero. These two facts are enough to explain the operation of this super-regenerator. For it can be seen from Fig. 2 that at the time when the plate potential is at its lowest value the grid potential is at its greatest positive value. We have just found that both these conditions are unfavorable to the occurrence of oscillations in the radio-frequency circuit, and hence if the tickler is not brought up too much, radio-frequency oscillations will die out rather than build up during this time. On the other hand, when the plate potential is at its highest value we have the grid potential down near zero; (see Fig. 2) and as both these conditions are favorable, oscillations will start up in the radio-frequency circuit and will have built up to a value proportional to the strength of the signal picked up by the loop when choked off

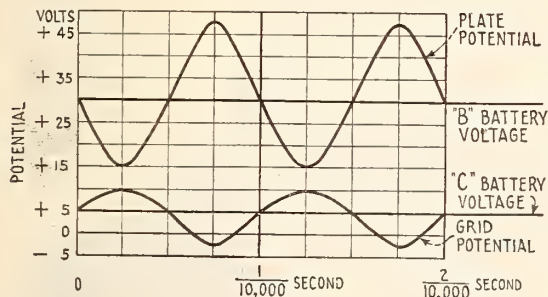

FIG. 2

mately represented by the curves of Fig. 2. The plate potential is seen to oscillate about the horizontal line representing the value of the battery voltage between plate and

\*Fortunately, however, it is not necessary to know all this to build and operate the kind of set which Mr. Roberts describes.—THE EDITOR.

by the recurrence of the unfavorable condition mentioned above.

The reason that the radio-frequency oscillations die out during the unfavorable period is that the grid is then highly positive and attracts a large number of electrons from the filament, and the energy expended in doing this is supplied by the radio-frequency oscillations which thus quickly give up all their energy, or "die out." This will explain the use of the positive C battery for tubes whose filaments give off so few electrons that the grid must be kept more positive in order to attract equal numbers and hence produce the proper "damping" effect. Another reason for using the

positive C battery is that it prevents the grid from ever becoming very strongly negative. For making the grid several volts negative is equivalent to reducing the B battery a good many volts, which we cannot afford to do when we have already cut down the B battery to one small  $22\frac{1}{2}$ -volt block for the sake of compactness and lightness. The unusual location of the C battery is for the purpose of making it act not only on the grid, but also in the plate circuit, on the principle that "every little helps."

Referring to Fig. 1, the parts include a loop, containing 23 turns of No. 24 D. C. wire, wound round the outside of the case ( $9\frac{1}{2}$  x  $13\frac{1}{2}$  x 3 inches. It might be better to devise a

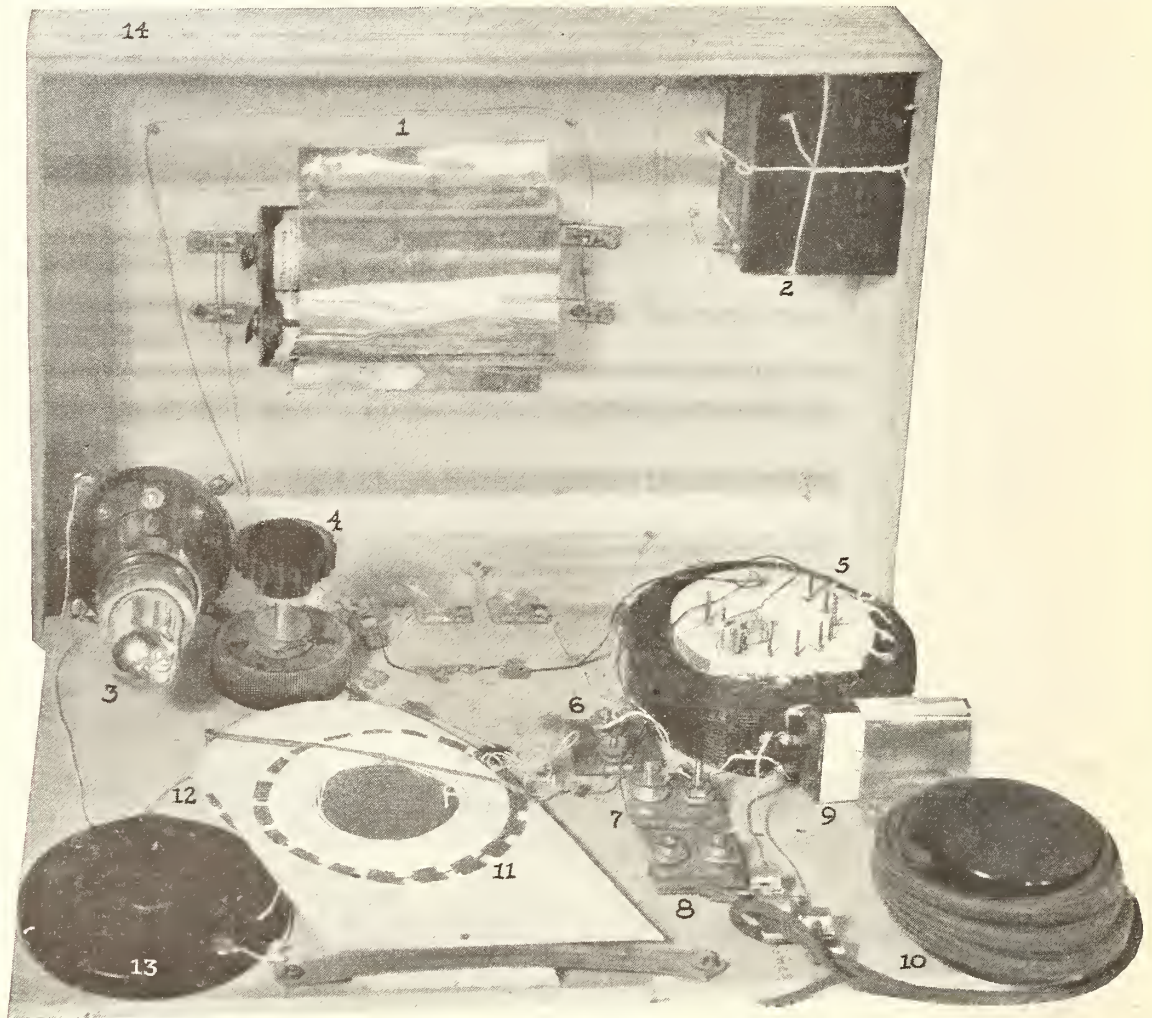

THE WORKS

The layout shown here may be altered considerably, since there is plenty of surplus room in the case. The numbers indicate the units used as follows: 1, 4 flashlight cells for A battery, in series-parallel; 2,  $22\frac{1}{2}$ -volt B battery; 3, UV-199 bulb and socket; 4, rheostat; 5, honeycomb coil of 1500 turns; 6 and 7, by-pass condensers each of .001 capacity; 8, condenser in interrupter circuit, .002 mfd.; 9, phone by-pass condenser, .05 mfd.; 10, phone, any type will do; 11, tickler coil; 12, grid coil; 13, Dubilier "Variodon" (or any other small condenser); loop, 23 turns of No. 24 wire



means of supporting these wires *inside* the cabinet); a tickler and a grid coil, wound on spider-web forms 2" inner diameter and 3½" diameter including teeth. 19 teeth are used and No. 28 D. C. C. wire is wound over three, then under three, etc., which gives three times as many turns on the same length of tooth as the ordinary spider-web winding. The wire is wound on fairly tight and up to within about an eighth of an inch of the ends of the teeth.

The variable condenser has to be compact. The one now in use by the writer is a Dubilier .0005 mfd. A Connecticut condenser will also go in the box.

The .001 and .002 mfd. condensers are Micadons. None of these values is critical, the first two being merely radio-frequency by-passes while the third determines the interruption frequency.

The 1500-turn honeycomb coil has to be tapped at several places in order to determine the best place. If the wire from the inside of the coil is the one connected to the grid, then the proper tap will be about one third the way from the inner edge to the outer edge of the coil. As the taps are very easy to make by prying up the wire slightly and soldering small wires on, it will be well worth while to make at least six taps near this point so as to find the best by experiment.

A single Baldwin receiver without head band is used. The phone by-pass condenser is a Federal (price fifty cents). One of large capacity is used in order to by-pass the interruption frequency. The B battery is a single small 22½-volt block, and the A battery consists of four flashlight cells in series-parallel, giving three volts and lasting longer than only two cells.

An improvement in operation will be possible when a sufficiently small rheostat of 25 ohms or more can be obtained, so that 4½ volts of A battery can be used (three flashlight cells), and as the battery runs down the resistance can be cut out. Fig. 3 shows the circuit in its recommended form. A sufficient positive potential for the grid of a Radiotron UV-199 is obtained by using the positive side of the A battery as shown.

In operating the set only two adjustments are required. The condenser is turned to the proper point while the tickler is kept just close enough to maintain the hissing sound characteristic of super-regeneration. When the tickler is brought too close the whole thing suddenly goes "dead." If you then withdraw

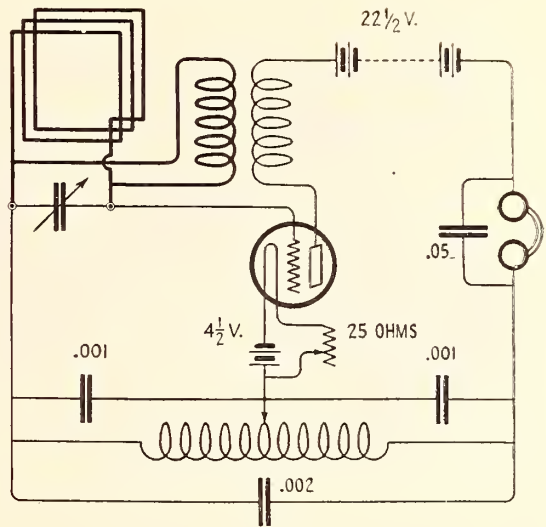

FIG. 3

This is the circuit which Mr. Roberts recommends. The arrangement in Fig. 1, however, is better for WD-11 tubes.

the tickler somewhat and touch the grid with your finger, the interruption frequency will start up again. The proper tap on the 1500 turn coil need not be changed after it is once found. It should not be so near the grid end as to let the advance of the tickler kill the interruption frequency too easily, nor so far from the grid end that the furthest advance of the tickler will not produce the proper hissing.

No claim is laid to any great ingenuity in space saving, so that the arrangement of parts will not be dwelt upon except to note that putting some of the parts in the box and some on the hinged panel makes available considerably more area, for parts that are not very high, than mounting them directly on the panel. It is probable that by careful designing the dimensions could be reduced to about 2½ x 9 x 10 inches, although it would probably be difficult to reduce the weight much below the present six pounds.

Such a set as this should be of value to those who want to be able to catch weather reports or time signals or special features once in a while, but who do not use radio enough to warrant the trouble of aerial and ground installations, or the expense and house room of an ordinary loop set. And it will perhaps interest also those who want to be able to carry a complete receiver—containing within the four walls of a small thin box everything including phones and batteries—from one place to another. With it, they can listen from an auto or boat, for instance, or at a camp—in fact, wherever their vacation-time travels may take them.

# Confessions of an Unmade Man

“Beware!” Cries This Miserable Wretch as He Goes Under for the Third Time

By R. O. JASPERSON

**A** YEAR ago I was a sober, respected citizen, loved of my family, welcome in the homes of my friends. I paid my bills promptly, kept my walks clean in winter and my lawn mowed in summer. In short I was, as you might say, a substantial member of that class of citizens who are the bone and sinew of our nation.

Look at me to-day. I am no longer sober. Once I could pass by where the deadly stuff is sold and never bat an eye. To-day, alas, my feet carry me into the open doors where temptation lurks. I am no longer master of myself. Gone is the respected citizen. No longer do my

friends welcome me; they shun me. My family is disgusted with me, my bills are unpaid, my walks are not shoveled, and my position is in danger.

My downfall has been rapid. A week before Christmas, little did I dream that such a change could take place. When I first heard the seductive whisper of the tempter and I yielded, knowing full well the fate that had overtaken my friends, I felt I was strong enough to “take it or leave it alone.”

That was at Christmas time. I shall always look back upon that happy season as the beginning of my ruin.

You see, it was like this. A friend, yes it was a friend who started me on the downward path, asked me to go with him to a place where they sell radio parts and sets. He had just been paid and there was a gleam in his eye. He hadn't bought so much as a piece of spaghetti for three days and I could see that it was useless to attempt to restrain him.

So I went with him. It was not a gilded den, but in spite of the crudeness of the furnishings, they had the stuff to sell. There it lay exposed to the greedy eyes of the poor wretches who were spending their hard earned cash for “parts.”

My friend ordered a variable condenser for himself and knowing that I didn't indulge, asked the bart—I mean the clerk—to show me a “set,” just a cheap little set costing \$10, while he poured tempting words into my ear.

“You can get WJZ, and KDKA, and WOR with this set.” Now I'm telling you. Just think of it, all those beautiful concerts, speeches, and think of the prize fights, “blow for blow”—those were his exact words—and last night I got Cuba . . . .”

“Cuba, did you say, Cuba . . . .?”

“Yes, I got Cuba, but you understand, not on this set. No, I've got honeycomb coils and two stages of radio and two of audio, and next week I'm going to get a loud speaker.”

I might have known from his raving how bad they get when once they fall, but I was heedless.

“Blow for blow.” Those words kept ringing through my head. “Concerts” and every-



## GONE IS THE RESPECTED CITIZEN

Once I could pass by where the deadly stuff is sold and never bat an eye. To-day, alas, my feet carry me into the open doors where temptation lurks: I am no longer strong enough to “take it or leave it alone”



thing. Only \$10. WJZ, WGY, KDKA . . .

Gentle reader, I blush to tell it, but the temptation was too great. I struggled, but struggled in vain. I bought the little \$10 set, but with the strong resolution that it would be all. I would show them I could take it or leave it alone.

I don't think my good wife realized how she contributed to my failure to stick to my resolution to be strictly temperate. As I look back, I see how her suggestion that it would be nice if we could both listen in at the same time led to my future excesses. I bought an extra pair of phones, a little matter of \$7, and a few nights later when company came to listen to our radio set, wife suggested we ought to have one of those horns so everybody could listen.

I threw caution to the winds and proceeded to read all the magazines I could get on the subject. My favorite daily newspaper did not publish enough radio information so I changed to one that must be owned by some fiend judging from the amount of space devoted to the subject. All the magazines except those dealing with radio lie unopened and unread upon my library table.

Before prohibition when a fellow indulged, it was hiccups. Now it is hook-ups. My pockets are full of them. I bought a book on hook-ups and with the words of friend wife ringing in my ears, I sought more volume, I craved distance, I yearned for selectivity.

From the maze of hook-ups I selected one that looked modest and easy to master. I bought the parts, some of the parts, I should say, and abandoned myself to the seductive undertaking.

My noon hours were spent in radio shops whither I went to get information about grid leaks and variometers. Always I bought more parts.

The office boy, also an addict, discovered my secret. The size and shape of the many packages I brought in each day betrayed me. He recognized them and one day came to me with a hook-up and asked my opinion. It was



#### THE OFFICE BOY AND I ARE COMPANIONS IN CRIME

We sneak off to the seclusion of the stock room to exchange hook-ups. Once the office boy's opinions on any subject were of no interest to me. Now I eagerly seek his advice

a subtle thing to do. Now, the office boy and I sneak off to the seclusion of the stock room to exchange hook-ups. We are companions in crime. Once the office boy's opinions on any subject were of no interest to me. Now I eagerly seek his advice.

Even without taking time to eat lunch, I find I have difficulty in getting back to the office at noon. The office boy is helping me buy parts. Yesterday he knew where he could get tubes at half price. I drew my last dollars out of the bank and dispatched him post haste to get three of them.

Next week I must get a certain battery. The grocer and butcher will have to wait. I must have that battery.

Where will it end? It can't go on. If I knew of a cure I would take it. I have tried to limit myself to a definite sum weekly, but resolutions are of no avail. My will power is gone. Money means nothing to me except a means of gratifying my consuming craving for parts.

There ought to be a law against exposing radio parts for sale. It is putting temptation into the way of the slave to radio. No effort is made to screen the shops where radio addicts congregate. The traffic goes on openly in full view of the young and impressionable.

Even mere boys are among the worst cases. I have seen mere babes of no more than nine or ten rush wildly into a radio shop and demand three honeycomb coils and a vernier rheostat,

throwing the money madly at the clerk and dashing away with the parts clasped to their eager breasts. It's a sad commentary on our American institutions. When you protest, the sad eyed clerk simply smiles and says, "We might as well take it from the children. If they don't spend it, their fathers will."

The other day I saw a well dressed man sitting in a radio shop in deep thought. His clothes were still in fairly good shape, although I felt that he had seen better days. He looked up as I passed and he must have recognized in me a kindred spirit, for he said, "I simply can't make it out. Nobody seems to be able to help me."

"Perhaps I can," I said, for I felt sorry for him.

Then he told me his story. "I have been addicted to the habit two years. I have built twenty sets and used every kind of hook-up from a crystal to a five-tube set with indoor aerial. I have spent most of my money and I thought I was through, but a few nights ago I was adjusting my variable grid leak when the darn set spoke up as I never heard it before. I tried laying a screw driver across the terminal and the knob, and it fairly shouted. I cut a piece of zinc about the size of the screw driver and it worked still better. Then I began to experiment, cutting larger and larger pieces of zinc, each time getting the tone louder and clearer. Then I ran out of zinc until I remembered an old zinc bathtub over on the dump. I got that and was bringing it home when

my wife introduced me to a gentleman who she said was to take care of me. He's out there now, see him? He's waiting for me to come out and take me back to the sanitarium. Well, I don't care, only I wish someone would tell me what made my set speak up like that."

I was unnerved. I realized what I was coming to. A few short weeks ago, all unmindful of danger, I embarked upon my career of debauchery and now I am without hope. All about me I see the bright, promising young men who will soon be like myself, ruined.

Go west, young man, go west—but no, it's as bad out there as it is here. But, at least, stop before it is too late. When temptation comes, and you have once given way to it, remember there is no cure.

Why do I pen these words? I would spare you the sight that met my eyes last night. Finding I needed a couple of binding posts, I stole out of the house to a low radio shop around the corner which keeps open all night. There was the usual crowd of men and boys, but what especially pained me was the sight of an unshaven man leaning heavily over a show case studying the display of "parts." Tugging at his arm was a wan little girl who was singing a song I had heard many years before, "Father, dear father, come home with me now, the clock in the steeple strikes one." But the man shoved her away with a muttered curse.

It was too much. I resolved to devote myself to saving others from the fate that had overtaken me. May these lines help. . . . .

## Radio as a Rent Inducement

By ALLISON EURAY

**A**N ENTERPRISING real estate firm in St. Louis, Mo. has conceived the idea of equipping each one of the fifty-four apartments in the Garden Court Apartments, located at 5330 Delmar boulevard, with a loud speaker (operated from a central receiving station), as an extra inducement for the renting of them. No charge is made for the radio service which goes in with the rent.

The apartment house has a central receiving

station with an outside aerial, and in each apartment there is a loud speaker which the tenant can connect or disconnect with a plug.

In a trial recently held, the receiving station has "picked up" Kansas City, Atlanta, Pittsburg, Waco, and other Texas points. However, information as to how the situation will be handled, when a half-dozen of the tenants get to arguing with the landlord as to which station is to be listened in on, has not been divulged.



# The "Ham" Set of an Old Ship Operator

Amateur Station 2ABM, at New Rochelle, N. Y., Resembles a Commercial Station in Many Ways. Remote Control is One of Its Outstanding Features

By ZEH BOUCK

Many a fellow has taken up radio to enable him to have a taste of travel and adventure. Several years later, when he has settled down, he often finds that he cannot keep his hand off a key or the receivers off his ears. The kinks learned as commercial operators are being used by amateurs like Mr. Parsons in home stations throughout the country.—THE EDITOR.

SOME weeks ago, two elderly gentlemen, both broadcast enthusiasts, were standing at a corner in New Rochelle, N. Y., exchanging the time of day and, incidentally, their achievements in radio telephone reception. A short distance away, rising high above neighboring buildings, was a wireless tower, which, catching the eye of one of the gentlemen, caused him to exclaim:

"Great Scott! That's some tower. The chap who owns that must have a wonderful station!"

The second man snorted disgustedly. He had experienced some interference, which, rightly or wrongly, he blamed on that particular station. "Good station nothing!" he replied. "Why, he's only an amateur."

The gentleman who spoke so vehemently knew little about amateurs, in general or in particular, and nothing about the equipment of the station in question.

This tower is visible many blocks away, and is, perhaps, the most spectacular adjunct to station 2ABM, owned and operated by Mr. Fred Parsons. The huge framework is built one quarter of two by two-inch spruce, and three quarters

of the resourcefulness and ingenuity of the amateur. It is all the more amazing when it is considered that it went up almost entirely at night and without plans except for



THE 100-FOOT TOWER AT 2ABM

the pre-determination that the base should be an equilateral triangle with twelve foot sides, and that it should taper so that the top, seventy-five feet high, would form a smaller triangle three feet on a side. The number and positions of the crosspieces were also approximately calculated. The tower was built up from the unreinforced earth, the foundations being laid after the framework was completed! These consisted of several thousand pounds of concrete poured into three holes dug around the base to which the uprights are anchored. The tower, though practically self-supporting, is additionally safeguarded against strong winds by guy wires. The mast on the top of the tower rises twenty-five feet above the platform, giving a total height of one hundred feet.

The transmitting antenna consists of four wires which fall almost vertically from the top mast to the roof of the shack, which reduces the actual lead-in to a few feet, and forms an aerial of the most efficient radiating type (vertical).

The outdoor loud-speaker shown below is operated from the power amplifier, which was especially constructed for the rebroadcasting on sound waves of special events, such as

prize fights, election returns and the World Series baseball games. It is built entirely of wood, five feet long with a three-foot square "bell." The standard Western Electric loud-speaker unit clamps to the rear end. Elevated on the antenna tower, this mammoth loud-talker can be heard over a mile away, and clearly understood at half that distance.

The station proper occupies the top floor of the garage shown at the base of the tower in the first illustration. Like the majority of efficient stations, the apparatus is, for the greater part, operated by remote control. The operating table, from which the functioning of the receiver and transmitter is controlled, is shown on the opposite page. Various high-current circuits are opened and closed by relays operated by the bank of keys on the panel of the left centre cabinet. Among the operations effected from this board are stopping and starting the rotary spark gap, closing the power line to the transmitting transformer, transferring the key from the wireless to the land-line sounder, and operating the N A light, which flashes from an illuminated wall map with the dots of the time signals. This last is accomplished by adjusting the grid bias on the final stage of power amplification, so that

the plate consumption of the tube, when quiescent, is zero, while the signals from Arlington will so unbalance the circuit, that the bulb will draw some fifty milliamperes. This is sufficient to actuate an especially designed high-resistance relay which closes a local battery circuit to the lamp. (This device could well be applied to tape recording instruments to facilitate the deciphering of code, as well as other interesting experiments in telemechanics. It might be necessary to reverse the connections to the secondary of the last amplifying transformer, in order that the grid be charged positively. The plate voltage should be above two hundred, preferably three hundred and fifty, and the grid bias on

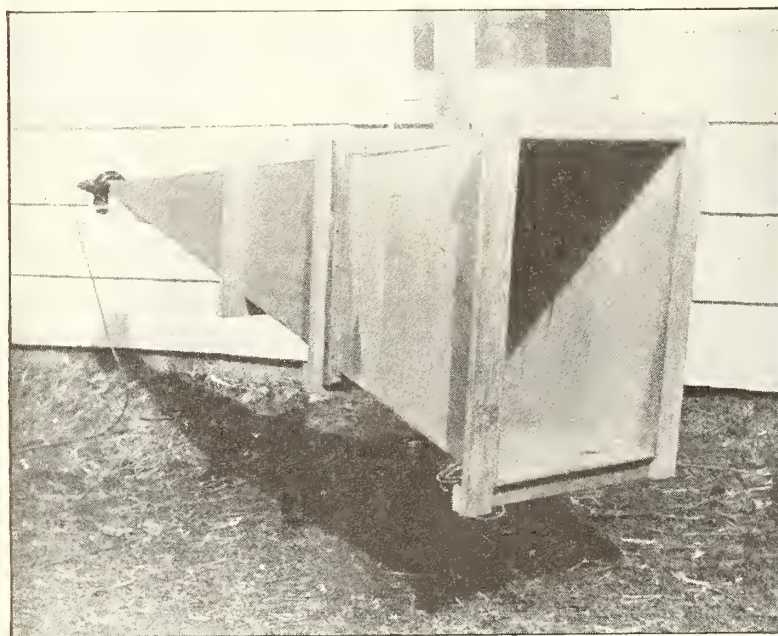

THIS OUTDOOR LOUD SPEAKER CAN BE HEARD A MILE AWAY  
Special events such as election returns, play-by-play ball games and blow-by-blow prize fights are re-broadcasted on sound waves, the loud speaker being hoisted up on the antenna tower





\*MR. FRED PARSONS, 2ABM, AT HIS STATION IN NEW ROCHELLE, N. Y.

some tubes may be as high as one hundred volts. A five-watt power tube should be used in the last step.)

To the extreme left in the picture of the operating room (above) is a land-line instrument, for Mr. Parsons is an old timer whose experience dates back to the days of Morse. The receiver to the left is a Paragon RA-10, with antenna series condenser, and detector and two steps mounted directly above. Two aerials are used individually for reception and transmission, the switch above the control-box disconnecting the single-wire receiving antenna from the set, protecting the delicate instruments from high potential surges. The cabinet to the centre right, originally a detector-amplifier for the honeycomb long-wave receiver next to it, is now common to both sets, a plug and jack arrangement permitting various changes of input and output. The telephone is an extension to that installed in the living quarters, which, however, is used only when a red signal

light does not indicate that the receiver is removed on the house phone. Similar red and green lights, at different parts of the station, indicate the functioning of various circuits. On the side of the operating table, arranged according to the practice of commercial stations, are in-and-out-going message blanks, 2ABM being an official relay station, covering a wide territory between the Mississippi and the Atlantic Ocean. The typewriter further facilitates and systematizes the handling of traffic.

The photo on page 27 shows the receiving high-voltage equipment and the connection rack similar to that in station 2FZ which was described in last month's RADIO BROADCAST. Below the land-line telegraph instrument is the B battery box with the side removed, showing the battery high-voltage arrangement, which consists, for the greater part, of flashlight batteries. This system has an advantage over the block battery in that the dead units, with



their material resistance, may be cut out of circuit.

The stove, reminiscent of the snowbound shacks of Marconi and Fessenden in the pioneer days, is a useful piece of apparatus on cold winter nights, and is worthy of its position in the foreground of the picture.

The panel just to the left of the stove-pipe is the high-voltage switchboard for the power amplifier, which is fed at three hundred and fifty volts from a dynamotor suspended in back of the panel. The dynamotor is operated from the storage batteries shown in the picture below, and the output is perfectly filtered, or the commutator hum smoothed out, by condensers and choke coils. Between the uprights of the connection rack are relays forming part of the remote control system.

In the picture below, the power and battery-charging switch-boards are shown, respectively, from left to right. The power board was

purposely constructed with adequate space for expansion. The relays in the upper portion close the circuits to the power transformer and rotary spark gap, a double operation controlled by a single relay, while the other functions as a key, following the dots and dashes of the light Morse instrument on the operating table. Another addition to the remote control system which will be effected in the near future, is a time element relay, which, operating independently of the rotary starting relay, will close the circuit to the transformer a few seconds after the starting key is depressed. This will make it impossible to transmit until sufficient time has elapsed for the spark gap to gain a safe operating speed, a precaution that is hoped will lessen the regularity with which condensers are blown at this station. The four-pole switch cuts off all power to the shack, including lights.

The charging panel consists of the necessary switches controlling the charge and discharge of the various batteries, meters registering voltage and current, necessary fuses, and the magnetic rectifier at the top of the panel.

The transmitter, as has been implied, is a spark set, Mr. Parsons being true to the old days that are symbolized in a booming gap. The transformer, an open core affair, is partially of home construction, it being a combination of the secondary of an eight-inch spark-coil slipped over a primary wound to consume one K. W. The secondary potential, judging from the spark and blown condensers, is in the neighborhood of fifty thousand volts. The transmitter is mounted in an especially constructed cupboard, the door of which is flush with the wall, an arrangement that effectually silences the roar of the gap.

Following the nationwide custom of the genuine amateur, in deference to

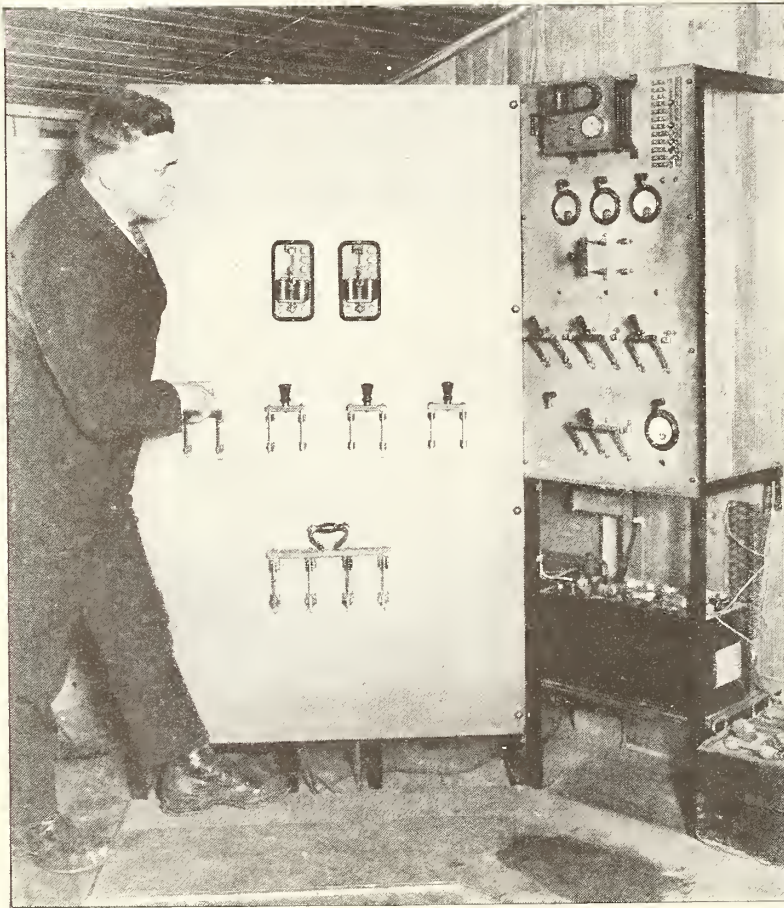

MR. PARSONS AT THE POWER SWITCHBOARD



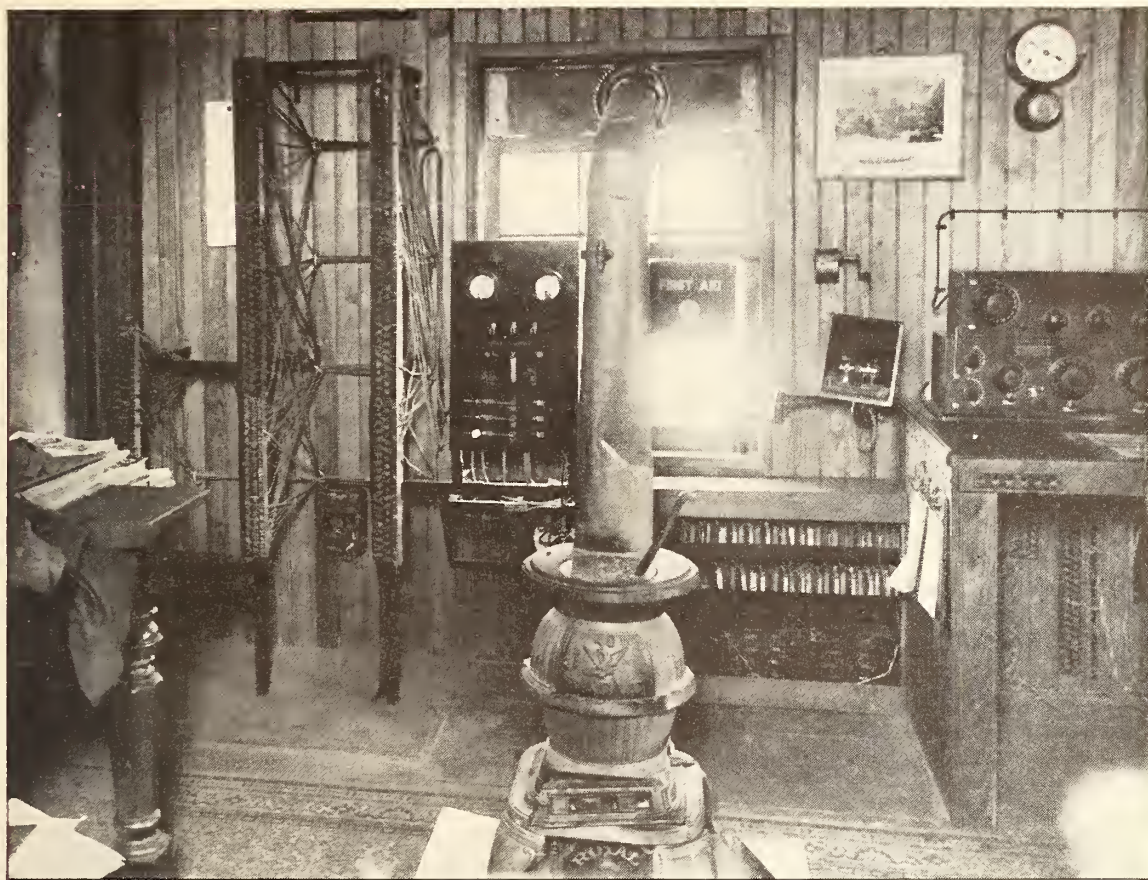

ANOTHER VIEW OF THE OPERATING ROOM

Showing the connection rack (at left), and the high-voltage B battery supply (at right of stove) consisting mainly of flashlight batteries. On cold winter nights the stove is as important a piece of apparatus as any in the room

the BCL (broadcast listener), the transmitter at station 2ABM is silent between seven and ten thirty P. M., excepting when operation is justified by some unusual necessity.

From the ship's clock on the wall to the port holes with which the windows are being replaced, the shack at 2ABM is reminiscent of the commercial experience that goes into the make-up of many amateurs.

Mr. Parsons operated many years ago on the *Pole Star* plying between Portland, Maine, and New York. Irving Vermilyea, one of the oldest of the old-timers, was his companion operator on the run. However, the radio careers of these gentlemen, as far as the *Pole Star* is concerned, were terminated somewhat abruptly in 1909, by an altercation between the wireless operators and the captain. The disagreement, whatever it was, came to a head on the homeward trip and Sparks, first and second, determined to sever connections between themselves

and the good ship *Pole Star* when they reached New York. After leaving the *Pole Star*, Mr. Parsons forsook the commercial game, and returned to his amateur station, then, long before the days of radio legislation, working on eight hundred meters. However, the lure of the profession was not dampened with Mr. Vermilyea, who, following it for a time on sea, and then on land, rose high in the game. Shortly before the war he was superintendent of the old South Wellfleet station, and is now manager of the transatlantic station at Marion, Massachusetts. But his greatest boast (if honest and deserved self-appreciation can be called a boast) is not of his commercial achievements, or even his peer of present day amateur stations, 1ZE, but goes far back to the days preceding the *Pole Star*, when he was, without a dissenting claim, one of the first amateurs in the world!

Vermilyea's first stations, when he signed

"VN," were the inevitable outcome of his immortal private telegraph line, that ran, with as much system as the streets of Greenwich Village, about the city of Mt. Vernon. There were forty or fifty "subscribers." Juice for the line was originally furnished from some hundreds of gravity cells in VN's cellar; and at regular meetings of the "subscribers," the hat was passed, soliciting funds for the purchase of copper sulphate. Things finally came to such a pass that the accumulation of glassware and blue vitriol was appalling, and it was then that the audacity and resourcefulness that made and kept VN an amateur came to his rescue. In-

spired one morning, he ran what was apparently a telephone line from his house to a bona fide pole; and from there, in a perfect imitation of the genuine article, it continued for some blocks, or until what VN considered was a safe distance from headquarters. Finally it crossed to a pole supporting the power feed to the Mount Vernon trolley line! Carefully hidden in a puttied up crack, it tapped the five hundred and fifty volts, and for five years the miniature Western Union was amply supplied with current. It is not on record that the tax for copper sulphate was discontinued.

## The Tuning Troubles of Messrs. Gallagher and Shean

(With Apologies to those Famous Men)

As Sprung on the Second District Amateurs at Their Recent Annual Banquet

By A. G. CLARK, 2 C N T  
Of the RIDGEWOOD RADIO CLUB

Oh Mister Gallagher, Oh Mister Gallagher,  
I was listening on the radio last night,  
But an amateur quite near seemed to like to  
interfere,  
So I'm going to kick and have him closed up  
tight.

Oh Mister Shean, Oh Mister Shean,  
In the radio game I see you're pretty green;  
As they say in gay Paree, what an animal you'd  
be——

What, an air-hog, Mister Gallagher?  
No, a jackass, Mister Shean!

Oh Mister Gallagher, Oh Mister Gallagher,  
Now I don't see why you put the blame on  
me,  
Everywhere I turn my knob I can hear the  
noisy slob,  
So it's not my fault at all as you can see.  
Oh Mister Shean, Oh Mister Shean,  
You are up against a problem what I mean,  
But there's something you can get that will cut  
him out you bet——

An injunction, Mister Gallagher?  
No, a tuner, Mister Shean!

Oh Mister Gallagher, Oh Mister Gallagher,  
Interference is no more I hear them boast,  
Cause a guy named Schnell has said that the  
old zink spark is dead——  
When the tube came in the spark gave up the  
ghost.

Oh Mister Shean, Oh Mister Shean,  
I can't get the situation through my bean,  
I must ask Sir Conan Doyle for when I burn  
the midnight oil——

You hear spirits, Mister Gallagher?  
No—spark sets, Mister Shean!

Oh Mister Gallagher, Oh Mister Gallagher,  
Station 20M is just a mile away,  
I can recognize his call but can't tune him out  
at all,  
Though he's on two hundred sharp I hear them  
say.

Oh Mister Shean, Oh Mister Shean,  
If you hear him high and low and in between,  
That "200" is a fraud, why he's on "180  
broad!"

Is that lawful, Mister Gallagher?  
No, it's awful, Mister Shean!



# Transmitting and Receiving with the Same One-Tube Set

By FREDERIC W. PROCTER

**T**HERE has been a need among radio enthusiasts for a combined transmitter and receiver of low power that could be placed, complete, in a single cabinet of medium size, and easily carried about. Until now, few instruments of this type has been placed at the amateur's disposal, and it is likely that the one here described will appeal, because of its extreme simplicity, to those who desire a transmitting and receiving set combined in one unit.

In this instrument, a single tube is used for both sending (telegraphy) and receiving (telegraphy or speech), and it is advisable to secure a tube that does not need too critical an adjustment of the filament when receiving, as it would be impossible to obtain satisfactory results in a circuit in which the change from trans-

mission to reception depends only on the position of a telegraph key. This key must have two contacts, making it possible to operate in two circuits, since in the up or off position it must make contact to close the receiving circuit and in the down position form the dots and dashes of the code. The placing of the key in this combined circuit is unique and makes possible the dual work performed. It will be seen from the following explanation that when the key is in the up position, during code transmission, the circuit is held open for reception. Another advantage of this circuit is that *once the operator has tuned the receiver to the station with which he desires to communicate, the transmitter is also sharply tuned on approximately the same wave.*

If the reader will follow the wiring diagram

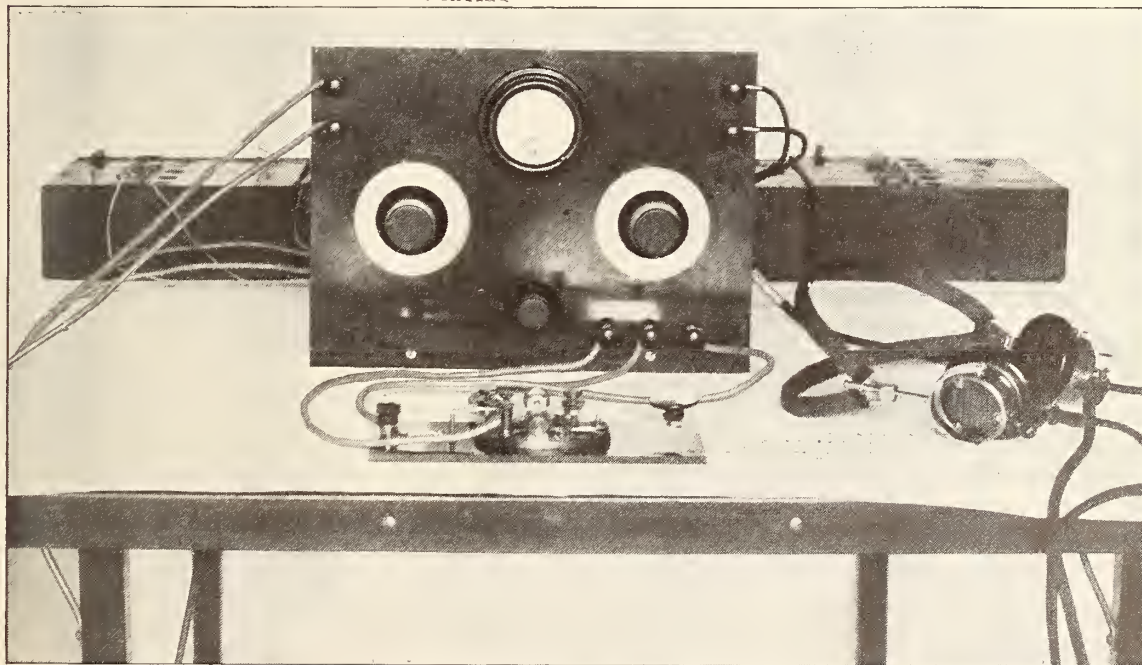

MR. PROCTER'S ONE-TUBE TRANSMITTER-RECEIVER

Showing the third key contact, with its binding post at the left end of the key base board. The left-hand dial controls the 43-plate condenser. The other large dial controls the secondary of the variocoupler, and the filament rheostat is mounted in the centre of the panel below the milliammeter

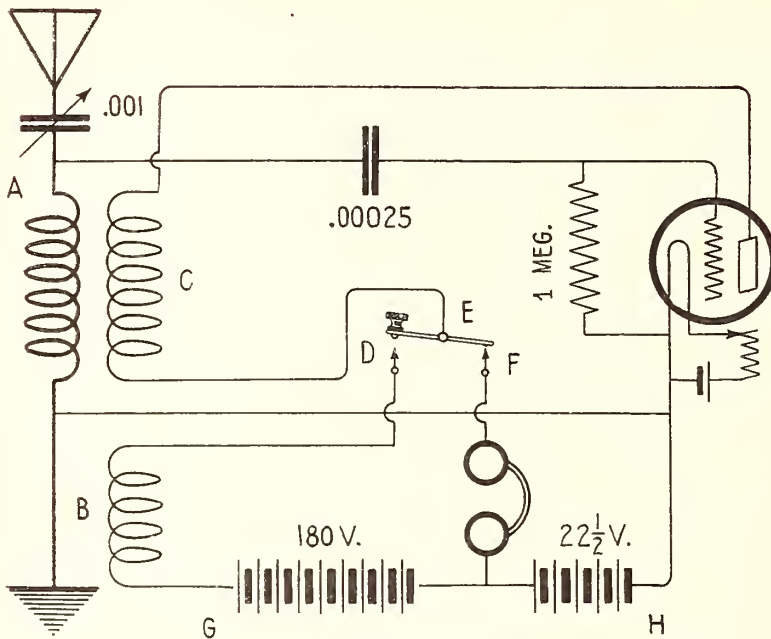

THIS IS THE CIRCUIT

Which is used in Mr. Procter's set. A, is the primary of the variocoupler made with a special winding; B; C, tickler coil; D, key contact used for transmitting; E, converted ordinary telegraph key; F, key contact for closing the receiving circuit; G, B battery for transmitting; H, B battery for receiving

closely while reading the description of the circuit, he should have no trouble in understanding the working principle of the system and afterward constructing the set itself.

The receiver is of the well known single-circuit type, and gives the necessary sharpness of tuning with a minimum of adjustments. A variable condenser of .001 mfd. capacity is placed in series with an inductance and the antenna, and due to its large range of capacity it provides a wavelength variation of between 175 and 400 meters, with an antenna of average size. The experiment of placing a vernier in parallel across the plates of this condenser was tried to determine the advisability of leaving it permanently in the circuit, but while the vernier increased the sharpness of tuning to some extent, it was not considered necessary to make it a fixture. The most satisfactory inductance unit that can be used in this circuit is a vario-coupler similar to the Baldwin type, as this instrument is particularly adapted to the needs of the set. It is necessary to make a slight change in the stator winding, to give a special plate inductance required in the transmitting circuit. At the tenth turn from the bottom cut the stator winding and remove two turns, fastening the ends in holes drilled in the

tubes. This divides the stator into two sections, the larger of which is used as the antenna tuning inductance, while the smaller is connected between one terminal of the rotor and the auxiliary source of plate potential used for transmission. This is used in series with the rotor or the tickler coil in the transmitting circuit, and its close inductive relation to the tuning inductance insures a state of oscillation when the telegraph key is depressed. For the benefit of those who may prefer to make their own variocoupler, it is advised that No. 20 B. & S. or a larger wire be used for the stator winding if good results are to be obtained.

In considering the grid condenser and grid leak, it is advised that a mica condenser of .00025 mfd. capacity be employed. The amateur may prefer to make this condenser variable and in some instances a variable capacity may be of some aid if the builder is experimenting with different makes of tubes. The grid leak should be of one megohm resistance at the most, since the impulses received are relatively weak, while the transmitted impulses, being generated locally, are relatively high.

The problem of selecting the right vacuum tube for this circuit is one that brings up many points for discussion, since the tube to be used must be one that will cover a wide range of work. It must not only give good service as a detector but must also be capable of taking a fairly high plate potential to give a strong output for transmission. For the set described, the Western Electric tube or V.T.1 was selected, since its filament adjustment is not critical and its insulation permits the use of plate potentials up to 200 volts. Much valuable knowledge pertaining to the functioning of various tubes can be acquired through trying them out in this circuit.

Next comes the problem of choosing the source of plate potential. B batteries have their advantages, giving a constant source of cur-



rent without the variations in potential common in other forms of plate current supply. Moreover, since no excessive voltage is required for this circuit, a few 45-volt B batteries are all that are necessary. They are to be found in any receiving station and can be purchased at a comparatively low cost. For the amateur who is making his initial attempt at transmission, this method should have a great appeal.

Another method—the use of a small dynamotor or motor generator—will be found satisfactory by those who already have one in their station, if it does not give too high an output for the tube used. It must be remembered that in this circuit the plate current for reception and the plate current for transmission will be in series when the key is depressed, and the plate of the tube will receive the sum of both potentials. Therefore, care should be taken not to overlook the fact that an additional  $22\frac{1}{2}$  or 45 volts will be added to the voltage of the motor generator or other source of plate cur-

rent being used. In purchasing the motor-generator or dynamotor, it is strongly advised that one of standard and reputable make be selected, since a cheap one is likely to be a constant source of annoyance and disappointment. It should have a large number of commutator segments for otherwise a most unpleasant generator hum will be heard in the receiving station. A dynamotor which supplies both filament and plate current will not possess the usual advantages in the case at hand, since it would necessitate the running of the machine to keep the tube lighted for receiving. The possibility of using house lighting current will have to be dwelt upon in a more lengthy manner than the two former methods.

First, 110 D. C. may be directly connected to the set. This system gives exactly the same results as those obtained by the use of B batteries, except that the potential often varies, dropping below 110 volts and rising again, if some excessive load has been placed on the house lighting circuit. This drop will

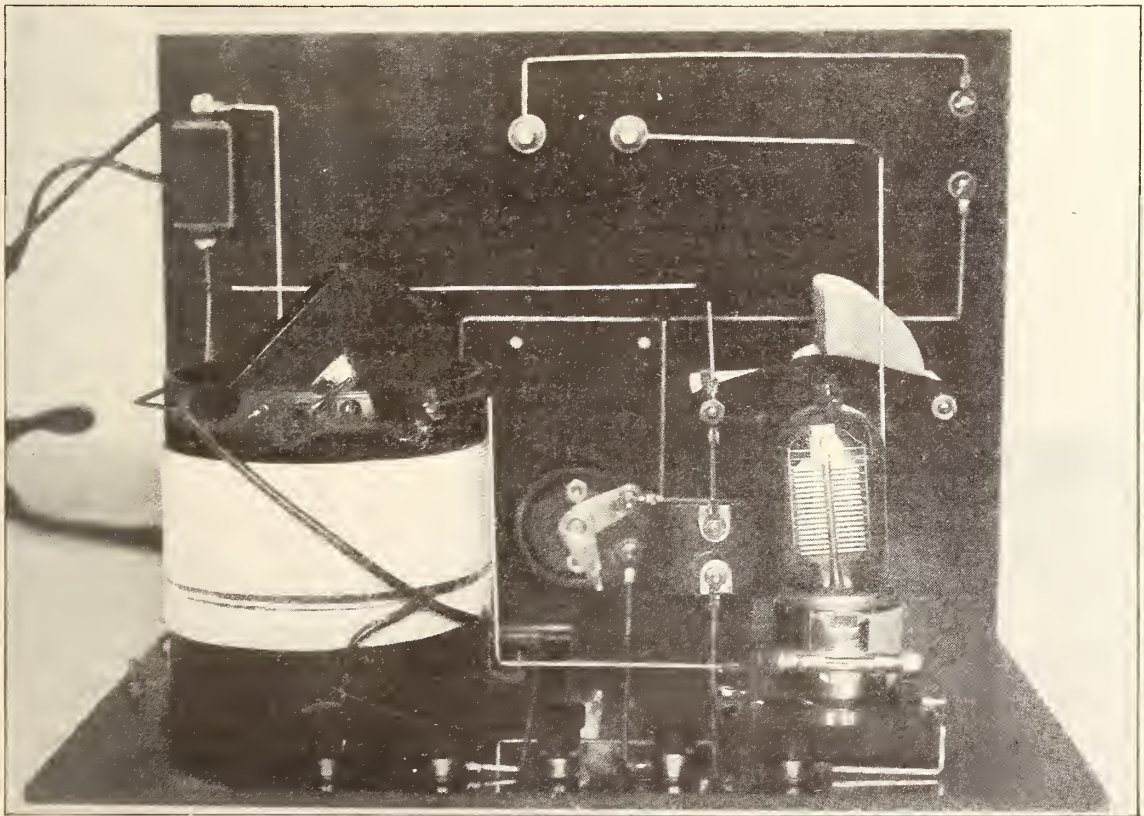

#### THERE IS NOTHING VERY COMPLICATED ABOUT THE SET

The tube in the picture, a Western Electric VT-1, has been found very satisfactory for the double function of transmitting and receiving; but other "hard" bulbs may be employed, especially where short distances are to be covered

naturally have an effect on the transmission in progress if the signals at the receiving station are weak, for a troublesome fading will be noted. If the current is sure to be constant this system can be recommended and good C. W. transmission will take place.

Where 110 A. C. is available, it may be used in several different ways.

The first of these is direct connection from the line to the set. The advantage of this system is that the quality of the signal transmitted makes reception possible over short distances with a crystal detector or some other non-oscillatory receiver, since the transmitted wave will be broken up by the set ceasing to oscillate during one alternation. The disadvantage of this system is that if sixty-cycle A. C. current is used, the transmitted note would be low and unpleasant to the listener.

If desired, the alternating current may be connected through a transformer to increase the voltage applied to the plate. This would still give an interrupted wave of very low tone, although the higher plate potential would increase the radiation.

The alternating current can also be rectified. One drawback of this system is the expense involved, but by use of a rectifying device the frequency of the current is doubled, giving a 120-cycle note at the receiving end. This note is much more pleasant to listen to, and allows the operator to use more speed in transmission, since the note is clear and the dots and dashes are sharply defined.

The use to which the transmitter is to be put will determine whether a filter should be employed. A filter may consist of a choke coil, large capacity condenser or a combination of both. The filter serves to smooth out the ripple in the 120-cycle current, permitting transmission on a continuous wave instead of a damped wave. The ingenious experimenter should be able, when using A. C. current, a rectifier and a filter, to put in

two double-pole-double-throw knife switches around his filtering system, permitting the use of either straight or modulated C. W. (continuous-wave) transmission at will. The use of either of these forms is a matter of preference, or will depend on the character of the work to be done. For the amateur who desires to use his set for field work, it will be found that B batteries are the most convenient source of plate current. For use in a permanent station,

several makes of storage B batteries can be obtained and if the station has a battery charger included in its equipment they will be found satisfactory, although for field work the dry battery excels. After reviewing the different methods of obtaining plate current that have just been outlined, it is up to the builder of the set to choose the method which he considers the best adapted to his needs.

As mentioned above, the key must operate

in two circuits, the receiving and the transmitting. By using one of the key contacts in both circuits, it is necessary to add only one more contact. First, the key should be mounted on a bakelite or wood base and a hole drilled one-eighth of an inch directly back of the end of the the key arm in the base. A machine screw should then be raised up through this hole and held in place by a nut. Then remove the nuts from the key adjustment in the rear of the arm and fasten on a small piece of strip brass which will extend out in the rear of the arm and make contact with the machine screw. Then replace the adjustment nuts to hold this strip in place, and the key conversion is complete.

It will be seen that when the key is in the up position the brass strip and screw make the contact in the receiving circuit, while in the down position the key contacts close the transmitting circuit.

It was not the author's intention to tell exactly how to build this set part by part, but rather to describe the circuit and explain the use of each instrument involved. Every experi-

### How to Get Your Transmitting Licenses

If you wish to transmit, you must have two licenses, one certifying you as an operator, the other for your station. You must be able to receive at least ten words a minute (five letters or characters to the word), and must comply with certain other requirements explained in the Government pamphlet: "Radio Communication Laws of the United States." It is advisable to obtain this pamphlet, as it gives a list of places where examinations are held and other information either necessary or helpful to the prospective operator. It may be had from the Superintendent of Documents, Government Printing Office, Washington, D. C. Price, 15 cents a copy.



menter prefers to build his set in an entirely different manner from any one else, some preferring to mount the instruments on a board, while others are partial to the cabinet arrangement. The set illustrated was built by the author and Walter H. Bullock, to whom a large amount of credit must be given for his aid and suggestions which helped the author prepare this article.

So far, a distance of eleven miles has been covered on transmission from the centre of

New York City up into the Bronx under very unfavorable conditions, and signals have been received from a broadcasting station in Chicago (700 miles). These distances exceed anything expected at the time the set was designed. It is hoped that many of you will derive pleasure and knowledge from this circuit and may do the kind of work with it that will make you feel that the time used in constructing the set was well spent.

## Have You Heard These Stations Yet?

CKAC in Montreal, WGR in Buffalo, N. Y., and WGY in Schenectady, N. Y., are Broadcasting Excellent Musical Programmes. Their Wavelengths are 430, 400 and 400 Meters, Respectively

**U**P IN Montreal, Canada, there is a French newspaper called "*La Presse*," which has installed a broadcasting station that is unusual in several respects. One man, Mr. J. N. Carter, performs alone the various duties of announcer, manager and operator. This he is able to do by reason of the special type of

broadcasting equipment which, although the station is a powerful one, is simple in operation. No motor generators are used, the alternating current supply from the city being passed through two giant rectifier tubes to supply the required voltages.

CKAC has a splendid pipe organ of its own,

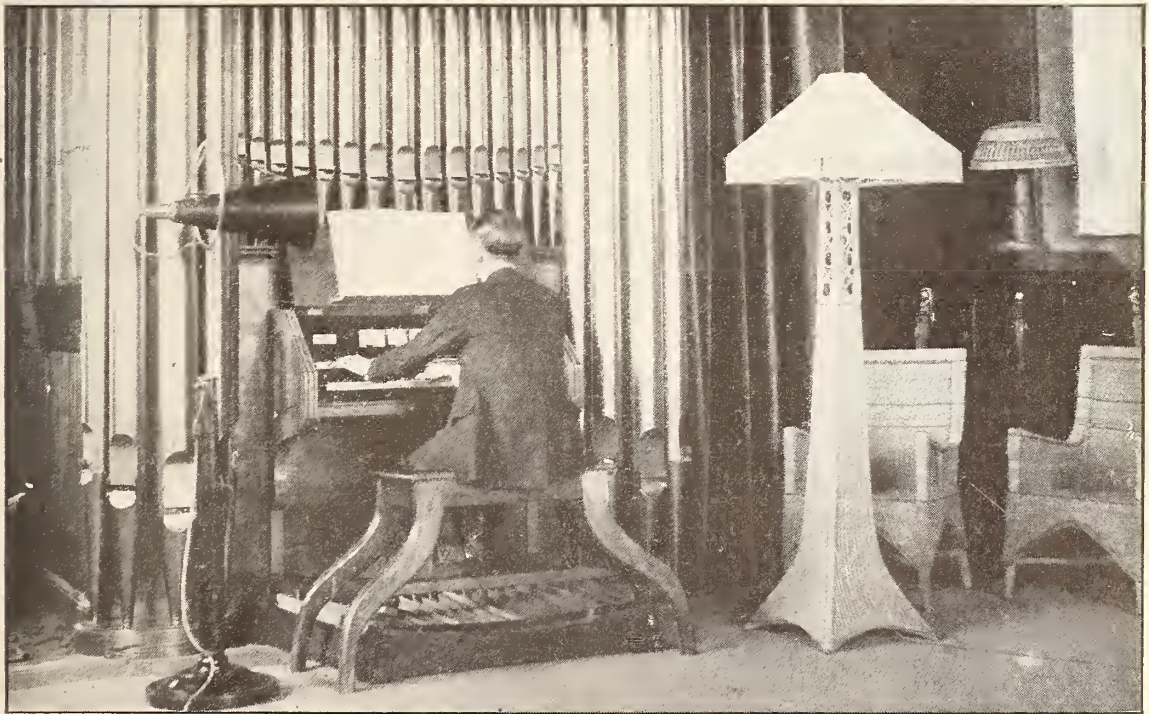

THE ORGAN AT CKAC  
Station of the French newspaper, *La Presse*, in Montreal



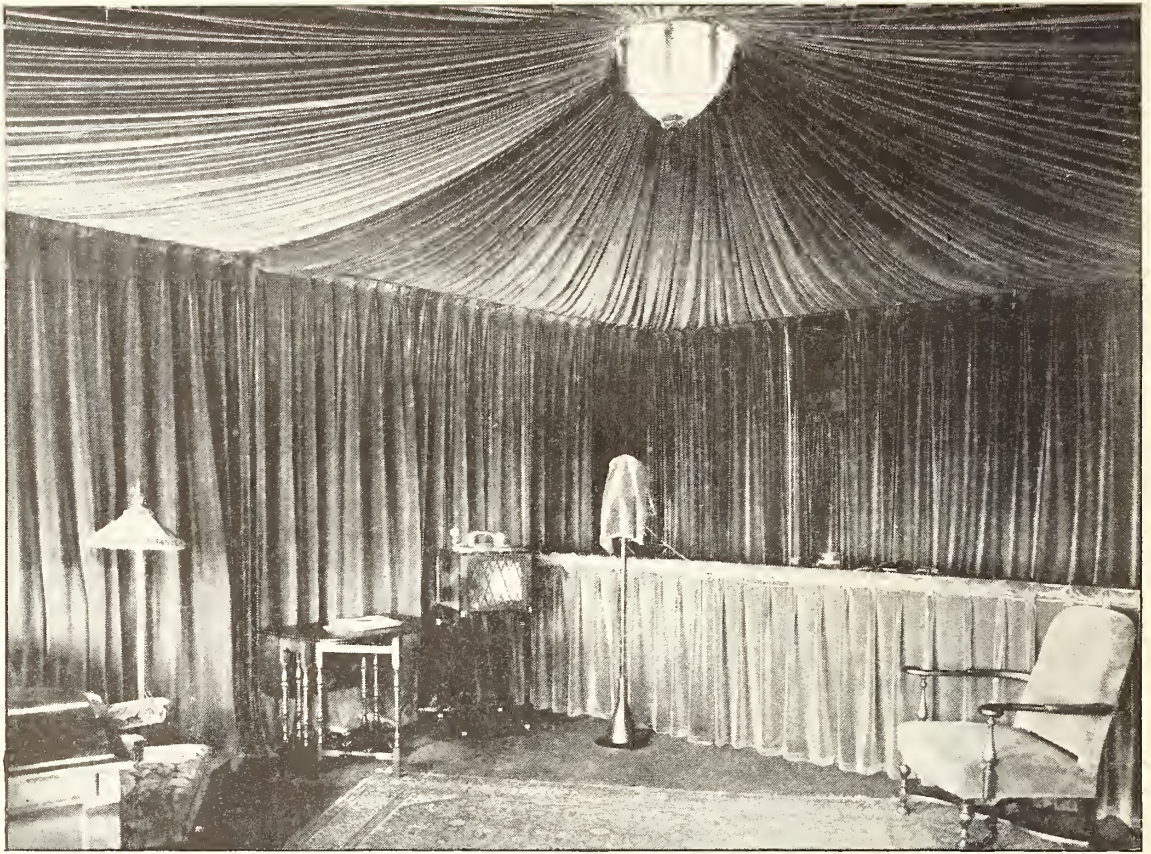

A CORNER OF WGR, BUFFALO, N. Y.

WGY'S ORCHESTRA AT SCHENECTADY, N. Y.





installed in the studio. The illustration on page 33 shows an organist giving a recital to an audience which undoubtedly contained as many Americans as Canadians. The language of music is, of course, universal, but the announcements at CKAC are made in both French and English, and the programmes, also, are given sometimes in one tongue, sometimes in the other. To tune in this Montreal station, you must "go up" to 430 meters.

The Federal Telephone & Telegraph Company has a station in Buffalo, N. Y., known to a large radio audience as WGR—possibly you have heard of it. It has been performing a useful service in transmitting weather and market reports as well as all manner of musical and other entertainment, and is planning to extend its scope to include educational courses of various kinds. The Broadcast Division of the Federal Company expects also to make

WGR a public forum for the discussion of matters of national and local interest. As will be seen from the picture on the opposite page, an elaborate system of hangings and floor coverings has been worked out which isolates the studio from all sounds but those desired for broadcasting.

A third station, which is gaining a wide reputation for its musical programmes, is WGY, the station of the General Electric Company at Schenectady, N. Y. It has a powerful transmitting installation and has been heard in every state in the Union and in several foreign countries. The orchestra which is shown in the picture has won the enthusiastic praise of listeners-in from far and near. These five players also supply the music for the light operas, such as Gilbert and Sullivan's "Pirates of Penzance," broadcasted from WGY from time to time.

## Supplying Broadcasts Like Gas or Electricity

How the Municipal Receiving Station in Dundee, Michigan, Relays Radio Entertainment to Private Subscribers Over Land Wires

By GRAYSON L. KIRK

**R**ECEIVING conditions in Dundee, Michigan, are unusually good. You don't need any aerial or ground. You don't even have to have a radio set. In fact, you can hear programmes from stations all over the country on nothing but \$1.50 a month and a loud-speaker.

Municipal radio is the answer; and Dundee, a little farming village of less than a thousand inhabitants, proudly boasts the first working system of its kind in the United States. This village, named after the Scottish community renowned for its marmalade, is located in the rich farming district of Monroe County, Michigan, along the banks of the River Raisin. There the tired farmer goes in from work, closes a switch, and without any tinkering with instruments may listen to a perfectly tuned concert from almost anywhere in the country. In the pool room on "Main Street," an eager crowd gathers on summer afternoons to listen

to Big League scores or Grand Circuit results. In the lobby of the little hotel across the street the college student, agenting for the summer among the farmer folk, may sit of an evening and listen to the radio concerts.

All this is now possible because more than a year ago, Frank W. Gradolph, President of the Farmers' Telephone Company of Dundee, had a vision—a vision whereby his company might render greater service to the town and community. He saw that one of the greatest handicaps to radio receiving was the even slight technical knowledge and expensive instruments necessary for satisfactory operation. And he saw still further the tremendous possibilities that would be opened if these difficulties could be eliminated.

The project at first seemed foolhardy, if not actually impossible. Obviously a central station and receiving apparatus were a necessity. But how could the sound be distributed from such a station without losing any of its tonal

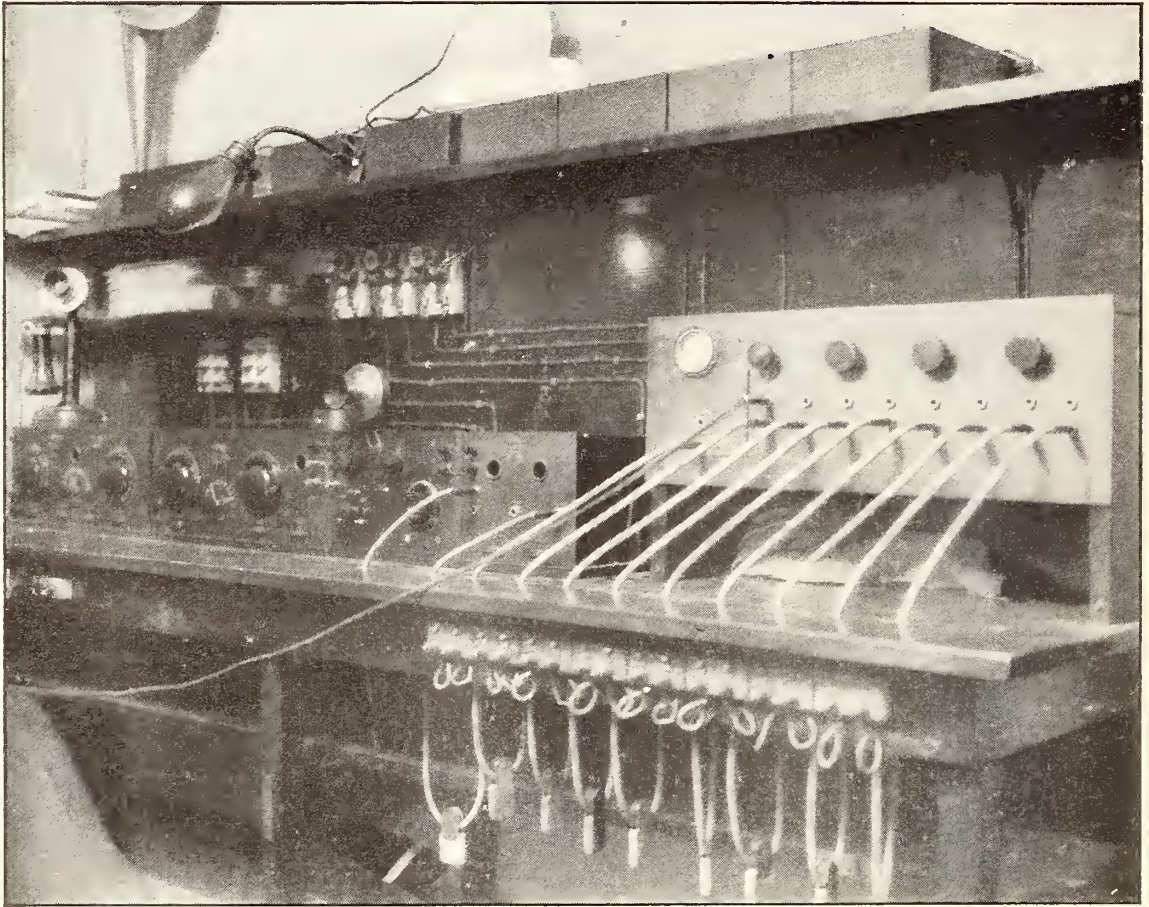

THE RE-BROADCASTING STATION AT DUNDEE, MICHIGAN

Here is where the entertainment for a whole community is tuned in every evening. It is transferred to land wires running to the homes of the various subscribers, who pay \$1.50 a month for the service.

quality? What sort of wire would be required? Would telephonic interference demand special poles?

These were a few of the problems that beset the originator of the project. He was undaunted, however, and after a stormy session the consent of the board of directors was secured and the work was begun.

First, a powerful receiving set was purchased and installed in the office of the telephone company. Batteries of a special design and extra strength were purchased. Then came the problem of a suitable aerial. The company erected a tall well-braced mast on the roof of their own three-story building and secured permission from the owner of a neighboring building to erect on its roof a similar mast. A customary four-wire antenna was stretched between them and connections were made. It gave splendid results in the little telephone

office. Could the sound be distributed all over town satisfactorily?

This problem of distribution proved to be the greatest obstacle the company had to face. At first a few loud speakers were installed in various homes about town and were connected to the central station by means of uninsulated telephone wire strung along on the telephone poles.

The result was discouraging. The sound seemed to have sufficient volume but the tonal quality was ruined. The music was changed into a blaring static-charged discord. The officials decided that the trouble was caused by the interference of the telephone currents and they set about to remedy the difficulty. They tore down the transmission wire and in its place substituted a medium grade of light insulated wire, such as is often used in house wiring.

The results this time were better, but by no



means satisfactory. So, profiting by their experience, the wires were once again torn down, and replaced with a very heavily insulated wire. More than six months had now elapsed since their first experiments, and the directors of the company were beginning to grow impatient. Would it be a success this time or were they again destined to fail?

Giving orders to the operator to open the circuit at a certain time, the officials hurried down to one of the homes that had a Magnavox installation. They waited in suspense; and suddenly there burst from the horn the sound of a voice singing. The tone was full and clear. The reproduction was almost perfect. The experiment was an unqualified success!

News of the success of the venture spread, and within a few days the office was besieged with townspeople clamoring for an installation. The troubles of the company, though, were not yet over, for difficulty in distribution arose almost immediately. As the number of phones or horns was increased the volume of sound steadily decreased, until the results were as unsatisfactory as before.

Various schemes of overcoming the trouble were tried and finally the electricians hit upon the idea of dividing the town into four dis-

tribution districts and effecting a quadruple distribution from these four main conduits. As a further aid, more powerful batteries were installed in the central station. Once again the results were satisfactory.

The entire mechanical force of the telephone company was placed on the work of installing and soon practically every home in the village was able to enjoy, without any technical knowledge or expensive receiving outfit, radio concerts and programmes picked up from many parts of the United States by the powerful central station.

F. W. Gradolph, the man who was credited earlier in this story with the original idea and subsequent realization of the project, is a quiet electrician and business man of early middle age, who takes a naive and pardonable pride in being able to provide this broadcast service at a charge of one dollar and a half a month to each subscriber.

It is the opinion of everyone who has witnessed the successful operation of the Dundee experiment that this community really "has something." Who will say how many Dundees, all over the country, will be adopting this system of municipal radio within the next few years?

#### THE MUSIC FLOODS THE LOCAL STORE

One drawback to this system of re-broadcasting is that if one subscriber doesn't like the selections provided, he cannot turn a knob and bring in something else. It's a case of take it or leave—the switch open

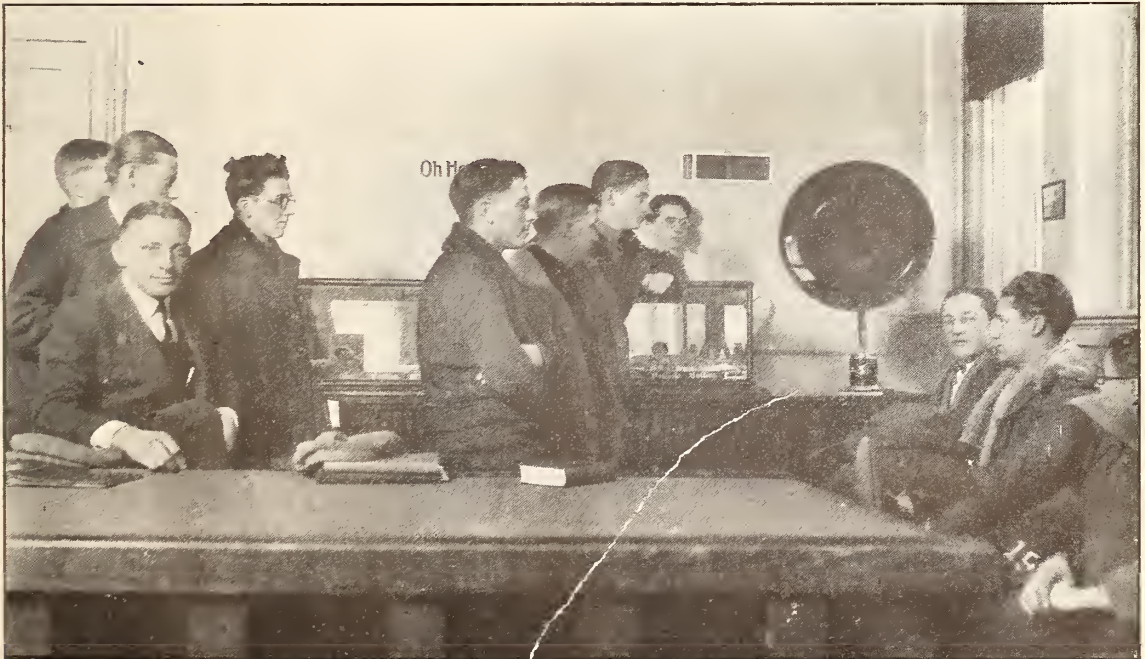

# The "Neutrodyne" Receiving System

Outlining the Hazeltine Method of Securing Radio Frequency Amplification Without Regeneration or Reradiation

By KIMBALL H. STARK

Chief Engineer, F. A. D. Andrea, Inc.

**R**ADIO enthusiasts speak freely of audions, pliotrons, dynatrons, super-regeneration and heterodyne; but now comes a new word—"neutrodyne."

Neutrodyne is the coined name for a revolutionary radio receiver circuit that seemingly achieves the impossible. It neutralizes the capacity coupling of the circuits and allows very efficient radio-frequency amplification even on short wavelengths. In effect, the usual regeneration of the circuit is eliminated by this method of neutralizing the coupling capacities.

On the evening of March 2nd, 1923, Professor L. A. Hazeltine, Professor of Electrical Engineering at Stevens Institute of Technology, Hoboken, N. J., delivered a lecture before a meeting of the Radio Club of America, telling in detail of his work which, extending over a number of years, has resulted in the development of the neutrodyne circuit. The application of this circuit to the problem of radio-frequency amplification is only one of the uses of the neutrodyne principle as developed by Professor Hazeltine.

Briefly reviewing the methods of producing

amplification in radio receiver circuits, we find that radio-frequency amplification can be obtained by using three possible methods of coupling one circuit to another, namely, resistance coupling, impedance coupling and transformer coupling. Resistance coupling is possibly desirable when wavelengths above 1,000 meters can be used, but the amplification per stage is not great and the tuning is broad. Impedance-coupled amplifiers when tuned are much more efficient and good results have been obtained from their use. If two or more stages of tuned impedance amplification are employed, however, the sharpness of tuning means very difficult adjustments and as a result cascade amplifiers of this type are not in general use. On the other hand, transformer coupling of amplifier circuits, because it has been standard practice with audio frequency circuits, has always found favor with both professional radio engineers and amateur experimenters as the ideal method of obtaining efficient radio-frequency amplification.

To date, two general devices for transformer-coupled radio-frequency amplifying circuits have been used; those employing air-core transformers and those having iron-core transformers. Circuits using air-cored transformers are extremely sharp in their tuning and the wavelength range of the transformers is necessarily limited. In cascade amplifiers of this type a multiplicity of controls is thus necessary, and very accurate tuning is required for each stage to get good results on the various wavelengths. For some time iron-cored transformers for radio frequency work were thought to be impracticable, due to the enormous eddy-current and hysteresis losses developed in the cores at

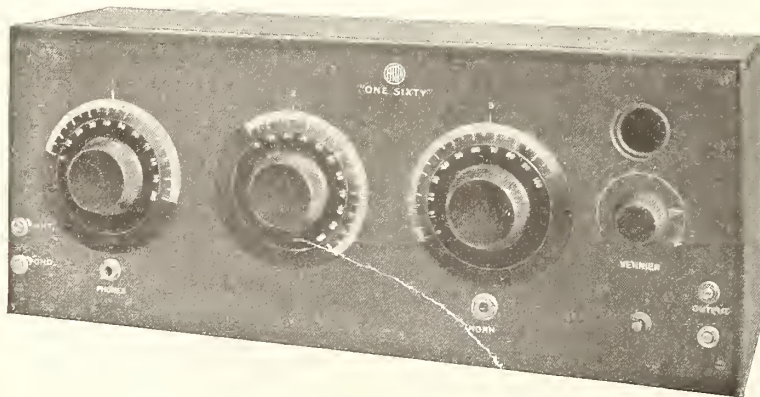

IN THIS NEUTRODYNE RECEIVER

All the tuning is done with the three dials. In a test made by RADIO BROADCAST, broadcasting stations over a thousand miles distant were heard on a loud speaker at night



these high frequencies. Later work with iron-cored transformers showed that by using cores made of special, very thin laminations and taking great care in the design and assembly of the transformer, quite satisfactory amplification could be obtained.

Special means were devised to broaden the wavelength band, but even as with air-cored transformers, it was impossible to utilize windings with a step-up ratio. Thus several stages were needed to obtain long distance signals.

As nearly every experimenter will agree, it is exceedingly difficult to hook up, even in the laboratory, either of these types of radio-frequency amplifier circuits and not get oneself into all sorts of trouble. At high frequencies the losses in the insulating materials used, the necessity for making all soldered connections of low resistance, and the very great drawback of the impossibility of eliminating the capacity coupling between the circuit and its various parts, make the problem seem impossible of solution. The matter of capacity coupling is obviously the most important. The capacity of the output circuit to the input circuit between the wiring of the set provides a path for a feed back of energy with the result that the apparatus oscillates. In broadcast reception using this sort of equipment the incoming signals are likely to be distorted, the overtones and undertones being eliminated, and the tuning accompanied by whistles as each carrier wave is crossed. In addition to the capacity coupling between the circuits the inductive coupling of transformers, inductances, etc., is also likely to bring this reaction about.

#### THE THEORY OF THE NEUTRODYNE

PROFESSOR Hazeltine in his lecture pointed out methods of overcoming, through neutralization, these various capacities between component parts of receiver and amplifier circuits. Theoretically his method may be explained as shown graphically in Fig. 1. We have two circuits, A and B, coupled to each other by a metallic connection C and, in addition, by the coupling capacity D. A magnetomotive force is set up in circuit B because of energy being transferred by the capacity coupling, a voltage and current transfer taking place. This condition in many instances is undesirable and decreases the efficiency of the receiver or amplifier circuit.

To make clear his method of neutralizing this capacity coupling between circuits, Professor Hazeltine explains by the drawing the use

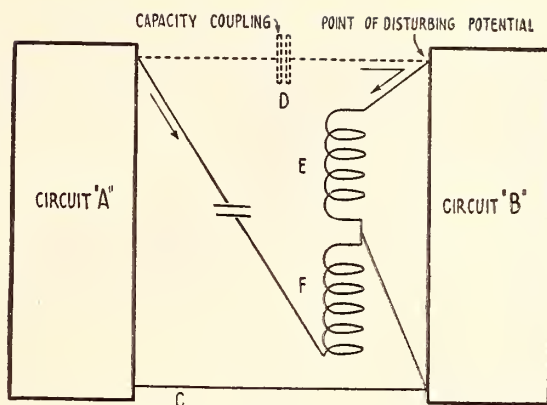

FIG. 1

A theoretical presentation of Prof. Hazeltine's neutralizing scheme

of an inductance tapped in the centre as shown. To the point of the disturbing potential on the circuit B one end of this inductance is connected and the other end is connected to a similar point on circuit A through an adjustable neutralizing capacity. The centre tap of this inductance system is connected to the low potential point of the circuit B. In effect, the path of the voltage and current is as shown by the arrows, with the energy caused by the parasitic capacity coupling D passing down through coil E in one direction and with the current and voltage in the opposite direction through branch F, going into the inductance system as an opposing voltage, thus inductively neutralizing the coupling capacity effect and causing no voltage across the terminals of circuit B.

As applied to radio circuits the drawing of Fig. 2 shows the device adapted to neutralizing the grid-to-plate capacity of vacuum tubes. In this circuit coils E and F are placed respectively in the grid and plate circuits while the centre tap goes to the common filament connection. The grid-plate capacity is shown by dotted lines and the neutralizing capacity is adjusted to offset the grid-plate capacity coupling. It is possible that the inductances E and F might be replaced by the inductances of other units as used in the circuit, as for instance the primary and secondary coils of an air-core radio frequency transformer. Professor Hazeltine showed that the character of these transformers affects the size of the balancing-out neutralizing capacity and that in his system it is possible to utilize transformers with a step-up ratio in the order of one to four and thus reduce the

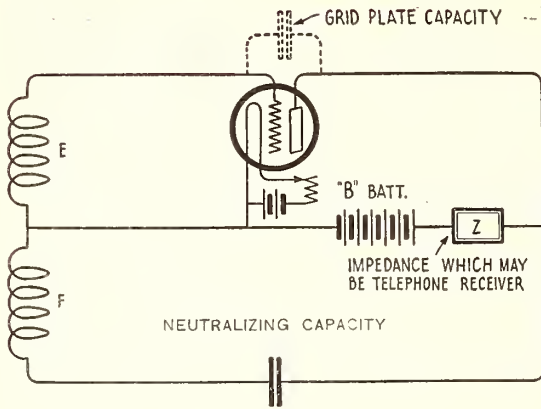

FIG. 2  
Applying the neutralizing method  
to a vacuum tube circuit

capacity of the neutralizing condenser to approximately one or two micro-microfarads.

In both of these explanatory drawings the capacity to be neutralized out or eliminated has been represented by dotted lines as being only a single capacity. In practice this capacity may be made up of a great number of small capacities whose total is balanced out by the neutralizing capacity.

Accompanying illustrations show interior and exterior views of a receiver built by F. A. D. Andrea, Inc., employing the Hazeltine principle in its commercial form. It will be noted that but four controls are used, three of them being tuning controls and the other being the detector tube vernier rheostat. Two stages of tuned radio-frequency amplification, a vacuum-tube detector, and two stages of audio-frequency transformer-coupled amplification is obtained, using only four tubes. One tube does double duty as both audio- and radio-frequency amplifier.

In the interior view the amplifying transformers are shown in the foreground. Three variable air condensers are mounted directly behind them and the transformers assume an angle with respect to each other such that no electro-magnetic coupling exists between them. The variable condensers shown in the wiring diagram in Fig. 4 are placed in parallel with the radio-frequency transformer secondaries, forming closed oscillatory circuits, so that dial settings for these condensers remain practically alike for any given wavelength. The settings of dial one, which is across the secondary of the transformer whose primary is in the open oscillatory antenna circuit, will vary

in setting with various sizes of antennas used. With the average antenna, however, it should not vary more than 10° to 12° above or below the settings of dials two and three counting from the left.

The important neutralizing condensers are pictured just above and between the variable condensers and transformer units. It is rather difficult to imagine a variable condenser having so small a capacity as 1 micro-microfarad and with the added advantage of having no connection to its moveable element. Such a condenser can be readily constructed. As shown in the drawing in Fig. 3 it consists of an insulated sleeve in which are inserted two pieces of wire with about 1/8 inch space between them at the center. A metal tube is adjusted lengthwise outside of the insulating sleeve over the ends of the two wires. The resulting capacity is the series capacity of the metal tube to both wires. After this capacity is adjusted during the testing of the receiver it is sealed, being adjusted carefully for the particular types of vacuum tubes used. The adjustment of these neutralizing capacities is made experimentally by tuning in a strong signal, then turning out the filament of the tube whose capacity is to be matched but leaving the tube in its socket. If the neutralizing capacity is not correct the circuits on each side of the tube will have capacity coupling which will transmit the signals into the receivers. The neutralizing capacity is then adjusted until the signal disappears, then sealed in place. Such a method illustrates that the neutrodyne circuit operates to eliminate the capacity coup-

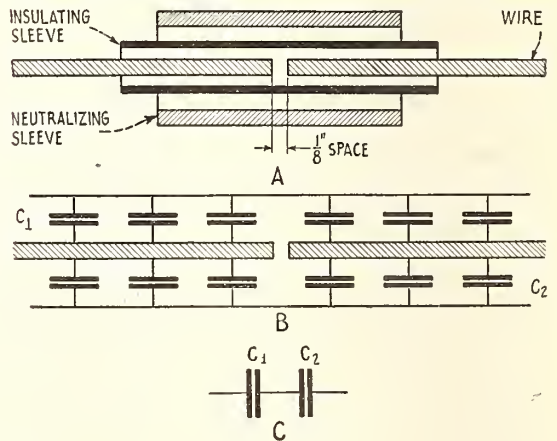
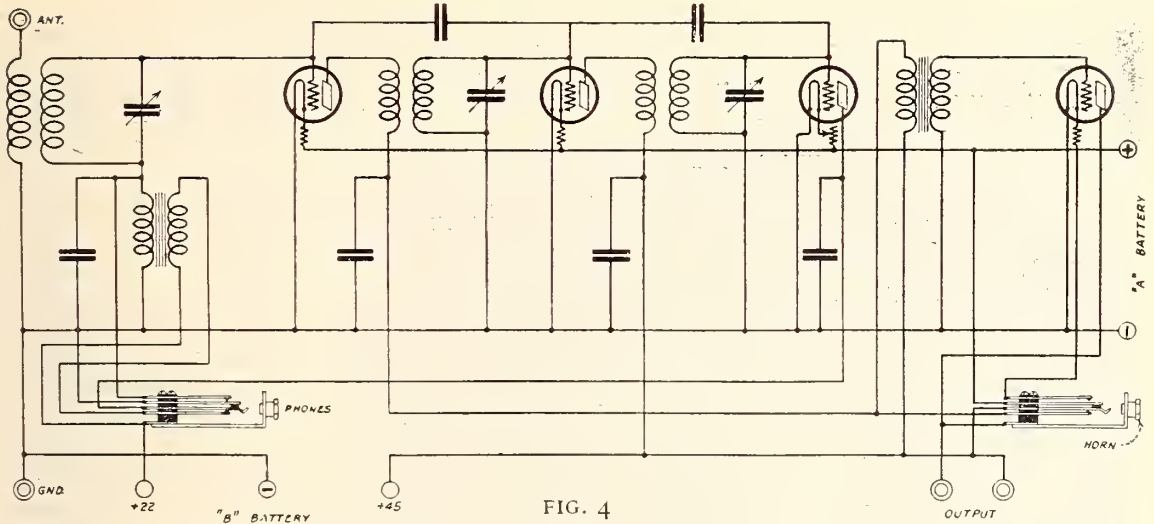

FIG. 3

The arrangement shown in A forms a condenser shown in B. The resultant capacity is the series capacity of the two rods to the neutralizing sleeve





THE NEUTRODYNE SYSTEM APPLIED TO A RECEIVER FOR GENERAL USE

In which there are three air-core transformers with tuned secondaries. The left hand one functions in the antenna circuit while the other two are used for the tuned R. F. inter-stage coupling transformers

ling and is not just a method for opposing the effects of regeneration, because the adjustment is made while the filament is cold and therefore under conditions when the tube could not regenerate.

With one of these receivers utilizing the neutrodyne circuit and only four vacuum tubes, three of the stations copied from New York City are noted below, together with the dial settings. In this work an indoor antenna was used consisting of about 50 ft. of annunciator wire running along the picture molding.

A glance at the dial setting indicates the sharpness with which tuning may be accomplished.

		Dial 1	Dial 2	Dial 3
KYW	Chicago, Ill.	35	66	66.5
WOO	Philadelphia, Pa.	35.5	67	65
WGM	Atlanta, Ga.	46	74	71.5

Another advantage of the neutrodyne capacitor neutralizing circuit is the fact that it can be used with circuits employing regeneration if desired. This means that amateur C. W. reception can be carried out successfully over very long distances; in fact, several tests made in New York City by amateurs not particularly familiar with the circuit have resulted in reception from every district in the country, stations from the

West Coast coming in clearly and with good volume.

From a non-interference point of view the neutrodyne circuit possesses great advantages because it does not re-radiate even when used in connection with regenerative circuits, because it does not allow energy to be fed back into the antenna—in other words, oscillation, if it occurs at all, is confined to the detector circuit.

The selectivity of the receiver is great and yet because no regeneration occurs it is possible for even the novice broadcast listener to adjust the three dials quickly and receive concerts with great clarity. Dial settings for various stations read like football signals, and to be able to have the women folks turn the dials to prearranged settings, throw in the filament switch and pull in broadcasting stations 1500 miles away, is a feat that even some of the older radio "night-hawks" envy.

THE INTERIOR OF THE RECEIVER

Is well planned. Note the angle at which the transformers are mounted to cut out electro-magnetic coupling. The brass sleeves which form the neutralizing condensers may be seen between the transformers

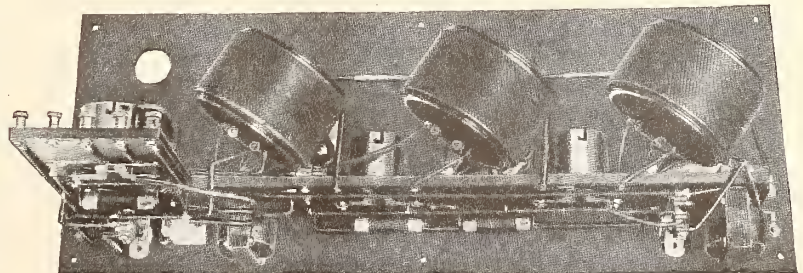

# An SOS in the Jungle of Indo-China

By LELAND L. SMITH

How a Distress Call, Flashed from a Remote French Outpost, Brought Airplane Assistance at the Critical Moment in an Uprising of Moi Natives

THE most easterly town on the coast of French Indo-China, Qui Nhon, lies at the door of the wildest hunting country that I have been able to find anything about. When I arrived there, looking for a bit of hunting and literally "a place in the sun" as a relief after campaigning in Siberia, only ten French government officials inhabited the place, but they immediately opened their arms to a former American army officer. While talking to one of them, I was suddenly asked whether I happened to come from Pittsburgh. Being a good Yankee, I replied with a question, asking why of all American cities he had inquired about Pittsburgh.

"Well," the official replied, "I am one of the only two living persons bearing the name of Duquesne, the founder of Pittsburgh; and it is my greatest wish to visit that city."

There was something interesting about this man who was keeping up the pioneering history of his family. We became good friends and he gladly gave me all the information that I needed. We had still another thing in common: Mr. Duquesne turned out to be in charge of the government radio station at that point and I had, shortly before leaving Siberia, been transferred to the wireless branch of the Signal Corps. I was naturally delighted when I was invited to visit his plant, which I found to be very modern and large enough to protect the shipping of perhaps the worst bit of typhoon coast in the world.

His stories about the China Sea were thrilling, but what whetted my imagination most

was his account of how a tiny French post, lost in the wilds of the Annam mountains, had been saved from annihilation at the hands of the Moi natives by the use of radio. It seemed that the natives of the mountains had yet to be brought under the domination of the French. Military posts were gradually being established in the interior, but slowly, as most of the Colonial troops were still in France and the native Annamite troops were too much of an unknown quantity to undertake the subjugation of the Moirs. Directly East of Qui Nhon, 200 kilometers away, was a post called Kon Tum which had no means of communicating with the outside world except radio. Telephone and telegraph wires had been strung several times, but wild elephants had destroyed them as fast as they were laid. Therefore, a field wireless had been installed at the post. An automobile road was in the course of construction but only half was com-

"After having spent a rather frigid time in Siberia fighting for democracy," writes Mr. Smith, "I decided to look for a place where I could thaw out. I hunted up a map of the world, and putting my finger on the equator, started searching for the most out-of-the-way, hot place on the globe. My eyes fell on Indo-China, and then and there I decided that Indo-China was the place for me." After reading the following account of his experiences there, we are inclined to think it isn't the place for *any* white man. But the French Colonials make existence in the jungle more endurable and less hazardous by the use of radio at their outposts.—THE EDITOR.

pleted, and the rest of the distance to the post had to be made over a jungle trail—impassable after a tropical rain—by ox-carts.

A year before, the natives, who are religious fanatics, had become excited over some fancied wrong to their faith and had attacked the post. Many were killed by machine gun fire but the Moirs, in their religious wars, seek death, believing that the supreme sacrifice in battle will render them salvation. The supply of ammunition had run low and the post was soon reduced to a state of starvation. There had been a succession of electrical storms that had temporarily put the field radio set out of commission, and it was only by hard work and good luck that the news of the outbreak was received



by the Qui Nhon station. It was impossible for relief to arrive immediately and it was doubtful if the handful of men that Qui Nhon could spare would be enough to cope with the situation. The lieutenant in charge of the besieged fort had the idea of calling by radio for two aeroplanes that were stationed at Qui Nhon, as the Moïs had always taken to flight upon the one or two occasions that planes had cruised over the country. The weather being favorable, the planes had set out and, upon arriving over the fort, dropped a few bombs and opened up at close range with machine guns. As if by magic, the natives took to their heels and had not bothered the post since. The French had since increased the number of planes on the Annam coast in case of a recurrence of the outbreak. But the machines were never allowed to fly inland often enough for the Moïs to get accustomed to them.

I was very much interested in the story and inquired whether it would be possible for me to visit the post, and whether I could obtain any big game such as tiger and elephant at the same time. I was told that Qui Nhon communicated with the post twice a day and if I would be at the station on the following morning at seven I could ask as many questions as I desired. It was finally arranged that I should go to the camp and participate in a hunt for a man-eating tiger that had been ravaging the neighboring Moï tribe. So, on the following day, I set out for the jungle post, loaded with equipment and supplies that the French officials had given me or recommended.

The first 100 kilometers were quickly covered by automobile over a road that led directly into the mountains and through dense

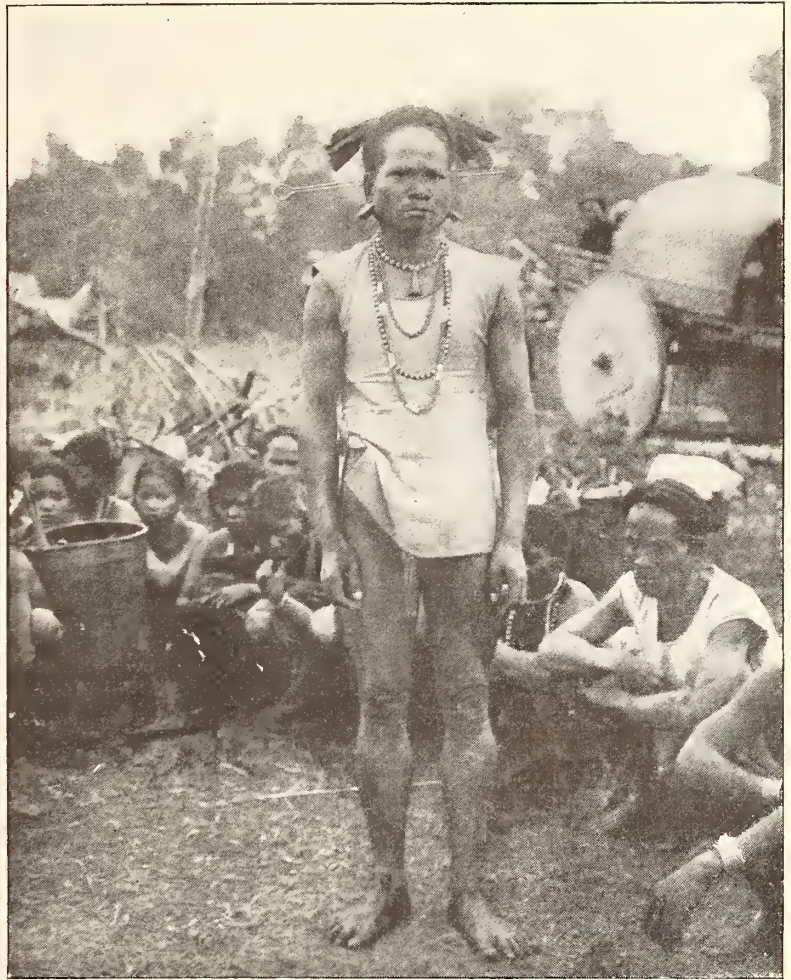

THIS MOI CHIEF THREW HIS VICTIMS TO THE ELEPHANTS

Lieutenant Gobert would have suffered this death, had not the author been successful in summoning French army planes by radio. The long double piece of wire in the chief's hair was originally part of some European cooking utensil. Note the large wheel on the native cart. Wheels of jungle carts are never greased in Indo-China, as the ear-splitting shrieks they make serve to keep tigers and leopards at a safe distance

jungles. Then I was bundled into an ox-cart and plunged into the dark country away from the white man's land.

A man who has never seen a real jungle cannot even guess at its denseness, or its vivid color. For hours at a time, it seemed, the bamboo "brousse," as the French call it, hid the sight of the sky, its long, curving stalks closing like a net over the thin trail. Flowering vines hung from the branches like Japanese filmy curtains. The solemn oxen, that carried me jerkily over the rough road, ruthlessly tore down the colored strands and munched the most exquisite orchids. Monkeys followed overhead, chattering and making a terrific



racket. Gay-plumed parrots, noble peacocks, deer, and wild boar were encountered continually. As the heat was terrific, the oxen were rested at every creek and I was able to peer into the jungle at close range. The length of my nose was about as far as I could get, and I thought to myself that Siberia and the Bolsheviks had been less dangerous than this new kind of No Man's Land. My white escort had left me, and four half-naked Annamites and one child had taken possession of me. Their apparent unconcern, however, reassured me.

The cart that was carrying me to Kon Tum had the largest wheels I have ever seen outside of a power house, and when they revolved they made a sound like the singing of every canary that the islands of that name had ever been guilty of exporting. An investigation elicited the fact that wooden hubs, revolving on wooden axles, were sending forth the air splitting shrieks that went echoing away into the jungle. The driver, who spoke an extremely Annamite-French, advised me that the noise was made on purpose as tigers and leopards never attacked a squeaking vehicle. He added that no person would ever get out of the jungle alive in a noiseless cart. From then on, the squeaks became the most beautiful music, and the louder they became the more I liked it.

We arrived at an open space shortly before sunset and preparations were made to spend the night. I had always dreamt of sleeping in a hammock suspended between two palm-trees and it was with a thrill of delight that I started to hang my swinging bed between two royal palms not far from the fire. The entire Annamite contingent protested violently. I was unable to understand why, but resigned myself to my fate and removed my stuff to the covered cart. After an exceedingly Annamite meal, which I could not eat (having seen it cooked), I sat down under the palms and watched the light of the day disappear over the jungle, or rather it seemed that the sombre, tangled forest arose and blotted out the light. Never will I forget the intricate laciness of the bamboo foliage; nor the majesty of the scattered royal palms as they struggled to retain the light a little longer than their less tall companions; or the weird calls that came from the depths of the jungle and were echoed again and again on my spinal cord.

A sharp pain on my wrist brought me to with a start. I naturally grabbed the outraged spot

and felt hot blood. Another pain struck me in the neck; it was so sharp that I cried out. The Annamites came running and dragged me from under the palms to the fire. I discovered several black worms about two inches long crawling on me. They fastened their heads upon an object, bringing their tails up to the head, and repeating the operation, they moved along with surprising rapidity. Their backs were kept curved after the manner of an outraged cat and they were extremely painful if your skin was reached; for immediately the worm began the operation of bloating itself with your blood.



“Sangsues! Sangsues!” shouted the natives with amusement; and it was then that I discovered why I could not sleep under trees. The worms were leeches that live on the branches and drop on their prey at night. Their bites are very deep and

the blood may run for fifteen minutes before it can be stopped; and the deadly, recurring forest fever often results from them.

With the crack of dawn, we were jolting and rocking again. We left the valley country and began toiling up crooked, mountain roads. The jungle gave way to pine trees, and tall mountains frowned down upon us from all sides. Mile after mile and hour after hour went by without the slightest trace of man. We seemed to be the only people in the world.

As the forenoon lengthened, we reached a great plateau, and in the distance a black spot was pointed out as our objective. Only glimpses of the fort could be seen from time to time through the large pine trees and I was not prepared for the formidable structure that suddenly appeared, dominating a large vacant plain from the top of a knoll. The fort looked for all the world like a copy of the old prints I had seen of the stockade-stronghold of the Pilgrim Fathers at Plymouth. A dry moat surrounded the post. On the inside bank, long pointed posts stuck out at an angle of forty-five degrees. Then came a tall, pointed stockade broken at frequent intervals with enfiling towers. At the corners were tall look-out posts. Bayonets flashed at intervals along the top of the stockade. A French flag hung from a tall pole.

We crossed the open space, which I noticed must have been prepared for aeroplanes and, as we approached, a bugle sounded. A draw-bridge was lowered and a French lieutenant



advanced to greet me. A few minutes later, I was in the officers' quarters trying to discover some part of my body that did not ache from the vibrations of the ox cart, and quenching my thirst with one of those long, cold ones that make you think that all has not been in vain.

The lieutenant, Gobert by name, was a slim, medium-sized man bearing the tan that comes only from years of life in the tropics. He was about thirty years old and his plain, khaki uniform did not have the vestige of a decoration, a sharp contrast to the gay bosoms of the Colonial officers I had seen. His eyes had followed mine and a slight blush suffused his face.

"I was one of the few Colonials that understood the Mois and were kept here during the entire war to prevent the natives from being carried away by German propaganda. I am still a lieutenant and have yet my laurels to win."

The lieutenant had spoken frankly and pleasantly. I felt that I was going to like him immensely.

"From what I have already heard about you and the Mois last year, I would say that your laurels have grown into a large-size tree," I hastened to answer.

Lieutenant Gobert laughed, replying: "The Mois are extremely interesting. They have no place in history and have apparently always lived in the mountains of Annam. The fact that they have been uncontaminated by surrounding races is probably due to the fact that the Annamites of the coast think the mountains are the abiding place of the worst devils, and the Mois are certain that sure death lurks on the plains. As a result, the Mois are perhaps the most uncivilized people in the world. But enough of this: it is nearly dinner time."



A CORNER OF THE DEFENSES OF KON TUM  
Showing the stockade with its sharp-pointed posts, set like bayonets against a possible attack by man or beast

In going to my quarters, I discovered that the buildings were in the form of a square and could be joined together by inserting sections of stockade, thus presenting a second line of defence. The feudal atmosphere of the place and the Annamite soldiers with their conical hats, long bayonets and vivid red-wrapped leggings above their bare feet thrilled me with delight. I was comfortably quartered and given an orderly. The place was a veritable museum of strange instruments of war, and it was with a sense of regret that I abandoned a bamboo arrow-gun to follow my orderly to the mess quarters. We passed through a charming garden to a large house, evidently of Moi pattern, raised off the ground about ten feet and

having a wide porch running entirely around it. On one side, a snowy white table was already set and the interior of the structure was the most perfect man's lounging room I have ever seen, with huge fire-place, deep chairs, hunting trophies and a riot of velvety skins. It was the only spot in the post that did not breathe war.

Our dinner was delicious, and when, as a climax, a heaping dish of luscious strawberries and cream was brought in, visions of home and Mother flashed before me. I was told that the post was at an altitude of five thousand feet and that temperate zone products flourished on the plateau.

We sat there a long time, watching the afterglow of the tropical sun on the mountain tops, and planning my hunting trip. It was decided that we would take elephants on the following morning and visit the neighboring Moi village where we would arrange for the killing of a buffalo, the building of a "kill" in which to wait for the tiger, and the engaging of a number of Mois to assist us in the proposed hunt. While waiting six or seven days for the slain buffalo to become tender enough to appeal to the delicate senses of a well-brought-up tiger, I was to be initiated into the excitement of electric searchlight hunting at night and the dangerous pastime of shooting elephants.

We were interrupted by a pretty young girl clad only in a colored, native skirt. Her hair stood out at least ten inches all around her head and her eyes were so black that I was startled.

Lieutenant Gobert spoke to her in her native tongue. The girl advanced shyly. After a short conversation, she made me the religious Lai courtesy of Annam and glided noiselessly out of the room, her dark, brown body seeming to fuse into the darkness.

The French officer laughed before making any explanations.

"That was Pocahontas, my Moi wife. Come," said he, rising, "Duquesne will be trying to get us on the radio. Let us go to the operating room and I will tell you the story of Pocahontas on the way."

Once out of the dark garden, the lieutenant continued:

"Most of the time there are only two white officers in a post like this. At the present

moment, I have a garrison of only sixty Annamites, since my colleague, Sous-Lieutenant Lancelin, and the rest of the force is fifty kilometers away on some surveying work. Our only communication with this force is by fire. At ten o'clock we will mount the observation tower and look for his signal that all is well. After you have done over six years of this kind of service, with only one leave in France, you will perhaps understand how all of the books in the world will cease to be the companion that nature has intended every man to have.



"The Mois are very tricky; you never know when and how you are going to hurt their feelings. About two years ago, I was unfortunate enough to kill one of their sacred bulls accidentally while hunting at night. I was instantly seized and condemned to be thrown to the elephants, which are instructed in the playful art of throwing humans high into the air, catching

them on their tusks and then kneeling on what is left after the first operation. This girl you have just seen pleaded with her father, the chief, for clemency—I had previously tried to buy her for a wife—but the old man had refused. So earnest was she in my behalf that the father allowed me to go. A few days later I discovered the little princess hidden in my room: she had run away from her tribe and said that she only wished to serve me as long as I wanted her. I finally struck a bargain with her father, but he swears that he will throw her to the elephants if she ever goes back to him.

"This all sounds like a fairy tale, but I have grown to love her and wonder what I can do with her and what will become of her when I am transferred home. I call her Pocahontas because Duquesne interested me in American history some time ago and the story of Captain John Smith and the Indian princess seemed to resemble my case somewhat."

As we entered the receiving room, an operator was busy receiving a message. I found that the radio set was a small one, not good for over one hundred and fifty miles under the most favorable conditions, but compact and just the thing for an outpost like Kon Tum. Lieutenant Gobert read me the gist of the message already received. Most of it was world news but Duquesne had slid in the baseball scores sent out by Cavite for my benefit. It was wonder-



ful! Here we were lost in the wilds of Darkest Asia, yet we figured out that the baseball crowds in New York were still on their way home.

When the native had ceased receiving, I asked the lieutenant for permission to send a message to Duquesne. "Pittsburgh—Pittsburgh!" I flashed out over the jungle wastes, experiencing a thrill of pleasure at the snappy crack of the spark. As quick as a flash the reply came back: "Heinz 57."

After a few minutes of exchange of compliments, I reluctantly followed Gobert to the look-out. At ten sharp, a red glow, that increased suddenly and then slowly died out, appeared on the far horizon. The lieutenant touched an electric button and an electric searchlight above us answered the signal. That was all; but the lights had sent a message that was full of meaning. I could not help admiring these men who were consecrating their lives to the demands of their country and carrying out their orders in the midst of a hostile country that might swallow them up at any moment.

Next morning, shortly after daybreak, Lieutenant Gobert called for me with two large elephants bearing protected baskets. Pocahontas was there also, stroking one of the beasts fondly. She had come to see her master off. Her shyness had disappeared and I was greeted with an expansive smile. There were five armed men in the first basket, not counting the driver, who sat pompously on the elephant's head. We mounted the second elephant and were joined by three more soldiers, making twelve of us altogether. There were enough bayonets sticking out of the baskets to frighten most any creature. The lieutenant gave a few orders, waved good-bye to Pocahontas, and we were off.

"She's a funny girl," Gobert remarked with a smile, having doubtless followed my eyes. "I have given her all kinds of European clothes, but she refuses to wear them, as she says that neither her mother nor her grandmother ever wore anything like them. If she ever sees a white woman, perhaps she will change her mind."

It took me a few minutes to become accustomed to the rather uncomfortable toddle of the

elephant, and for a while I had grave fears for my breakfast. After leaving the stronghold, we first crossed the great open space that lay before it. Lieutenant Gobert went on, waving toward the plain:

"The maintenance of this field absolutely free of all plants capable of hindering a plane is my greatest charge, because, if the Mois should suddenly rebel, I count absolutely upon the assistance of planes, as there are no troops available that could get here quick enough in an emergency."

"Have the Mois any firearms?" I inquired.

"No; but they have bamboo guns that shoot extremely dangerous poisoned darts. Also, they are very accurate with blow-guns. They have no fear, wishing to die in war, as it assures them of the favor of the gods. It is no sinecure fighting hundreds of these natives with a few guns and a limited quantity of ammunition that deteriorates more rapidly than it

can be replaced in this tropical climate."

"It is very fortunate that you have a radio set," I remarked.

"I should say so; the radio is really our protector. You think that I am isolated now; just think how much more difficult the position of my predecessor was before the days of the radio!"

We had plunged into the forest. Large pine trees lined the roads interspersed by tropical foliage in the low places. The elephants fascinated me as they tore down all the low, hanging limbs that would otherwise have scraped our car. In one place we passed a curious collection of houses surrounded by a high paling of tree trunks. Wicker roofs rose sharply from their narrow bases and met forty feet overhead like the edge of a razor. Colored woods were worked into the roofs in peculiar designs. I was told that each house represented a family vault, some of them containing twenty wrapped bodies; and the strong stockade was to prevent the dead from being consumed by tigers.

Shortly afterward we reached a village of many houses clustered around a large square. They were all made of grass, rested on piles from eight to ten feet from the ground, and had flat sloping roofs. Upon our approach, crowds of naked children, and natives clad only around the centre of the body, swarmed down the lad-

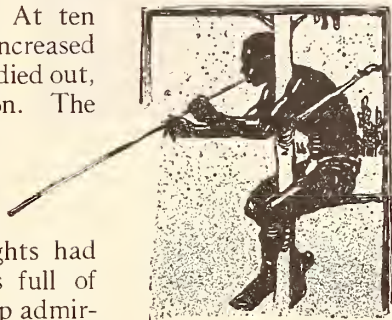



Courtesy of the *French Colonial Digest*

A BIT OF THE COUNTRY WEST OF QUI NHON

Once in the tangle of tropical growth beyond the falls, it is impossible to see more than a few feet in any direction, and it is dark and strangely silent

ders of their houses and curiously inspected us, always keeping at a respectable distance. At the far end of the square was a building of considerable proportions which my conductor announced was the domicile of the Chief. We had hardly time to descend from our elephants before the great man appeared, protected by several extraordinary muscular soldiers armed with spears, grass shields, and bow-guns.

The Chief was dignity itself in a native woven shirt, black towel tied around his head with its ends flapping on either side, several strings of beads around his neck, round pieces of gold in the lobes of his ears, and a long double piece of wire from some European cooking utensil stuck through his twisted hair at a rakish angle.

Lieutenant Gobert addressed him in his own language, presenting him with a package of cigarettes. Not a trace of a smile broke his feature or those of his attendants during the interview. Suddenly he made a signal, turned and entered the house, leaving us to ourselves. Gobert announced that we had been promised a number of Mois but they would have to be paid in advance. At that instant a number of stalwart men advanced. I took out my purse, insisting on paying the necessary costs. Lieutenant Gobert burst into laughter, directing me to offer each native a couple of Indo-China bills. The men took the money, examined it coolly, and handed it back to me. The lieutenant explained that the bills were in payment for their work as guides, but they immediately

protested violently, turning on their heels to go away. It was then I realized that money was an unknown article to these simple natives. Lieutenant Gobert produced some pieces of cloth, beads, and brass bracelets which were divided among them. Not even then did they smile. Their stoicism was most disagreeable and I realized what unpleasant folk they would be if aroused.

We were soon again on the march, our Moi guides following after. I was told by Gobert to watch out for the Chief's elephants, as we were soon to pass

them. Great snorts greeted us as we came to several strong stockades almost obscured by clouds of dust. I was greeted by one of the strangest and most awful sights of my life. Ten elephants with long, curved tusks, the ends of which had been sharpened by the addition of steel points, were throwing grass manikins into the air and catching them deftly on the ends of their tusks. After doing this several times, they cast what was left of the forms on the ground and trampled them. The elephants were undergoing their daily training.

The forest soon became so dense that we had to dismount our elephants. Gobert superintended the killing of an old buffalo, and a blind was made from where we were to shoot the great cat when he had been attracted by the odor of the dead beast. The huge buffalo, although weighing over two thousand pounds, was chained to a tree to prevent him from being dragged off by the tiger.

The following night we started on our first hunt. Gobert fitted me out with an electric searchlight that was fastened to my hat and connected with some batteries strapped to my belt. I was then given a lecture on eyes: red eyes announced a member of the cat family: if they were small and close together it would be a leopard, but if they were large and far apart it would be a tiger. On the other hand, if the eyes were green, they belonged to a member of the deer family.

Trying to keep this information in my mind, I plunged with Gobert into a jungle path, fol-



lowed by several Mois. I was told to keep my searchlight flashing on the trees to anticipate any lurking panthers while my companion was to cover the ground, since he did not care to run the risk of my killing a sacred bull as had happened before with disastrous results. All of the awful sights I had ever seen paled in the terrible aspect assumed by the snarled, dark, dank jungle that closed in upon us. The hanging vines, apparently brought to life by the flashing searchlights, looked like writhing snakes waiting to clasp us in their clammy embrace. Owls kept me on the jump as their eyes would flash like a match in the night as they flew before us.

Suddenly two lights shone before me and disappeared before I could decide whether they were green or red. Two more followed to the left; and still two more to the right. I brought my rifle to my shoulder but Gobert whispered in my ear that they were deer and not to shoot as it would frighten the big game we were after. I have never seen anything prettier than the lovely animals as they slunk away into the woods after having been momentarily hypnotized by our searchlights.

We came to a branch in the trail and I was told to take the one on the left until it met the other a few hundred yards ahead. I had not followed it long before I came to an open space. I heard a noise, and flashing my light in the direction of the disturbance I found myself looking into a pair of huge eyes. A second later I had fired. There was a terrific crash. I carefully went forward, expecting to see a great tiger stretched out on the ground. Finally, the light revealed my prey. I became transfixed with terror: a huge animal lay before me with several Mois shrieking beside it. Upon seeing me they fled, followed by our own escort, and I was left alone—alone with a dead sacred bull.

A moment later Lieutenant Gobert rushed up. When he saw what had happened, he seemed to turn to stone. Not a word did he

utter after his first ejaculation: he stood motionless looking at the bleeding animal before him. I tried to explain how I had been sure that nothing in the world but a tiger could have had such large eyes; how terribly I felt about it. But he heard me not, and I lapsed into silence, my intuition telling me that the consequence of my error would be disastrous. Suddenly he turned on his heel with a curt "Come; we must act quickly."

Without another word I followed him to our elephant and suffered the torments of the damned on our trip home. Gobert smoked one cigarette after another, often not waiting for one to be consumed. The frightful consequences following the killing of a bull two years before flashed though my brain with foreboding vividness. I could think of nothing but being tossed aloft by furious elephants, and of fruitless radio SOS calls.

Upon our arrival at the fort, Gobert led me immediately into the radio room and carefully locked the door. He gave me a pad and pencil, and proceeded to give me directions.

"There is only one thing to do: I must go to the Chief personally and forestall any religious uprising that may follow.

"Nothing of the kind; it is I who must bear the consequences," I interrupted.

"You could do nothing, and besides, you



STRIKING INTO THE DENSEST JUNGLE

A hunting party out after tiger. The journey would be practically impossible on foot, but the lumbering, pitching elephants are excellent mounts for this sort of work—if you are a good sailor

must take charge here until the other detachment can get back. You will at once keep a fire signal going until answered by my lieutenant. Then you will keep at this radio set until you can get Qui Nhon. They do not usually take messages before 7 A.M. but you must call every five minutes all night in the hope that for some reason that God only knows Qui Nhon may be able to pick up your call. You will tell them of what has happened and to send aeroplanes at once, for there is no time to lose. If I don't come back, have the planes bomb the Mois. But in no event open the gates of the fort until the planes or Lieutenant Lancelin arrive."

I protested, warning him of his danger, but was finally convinced that he, knowing the Chief, was the person to go. With a last few directions and a warning not to tell "Pocahontas" where he was or what had happened, he was gone. He was to take one elephant and five armed men, one of which was to drop off the elephant just before entering the Moi camp and return to the fort with news of the party's fate.

A moment later the Annamite radio man came in and we began our frenzied attempt to call Qui Nhon. The soldier was visibly frightened, although he did not know just what had happened, and I felt that the small Annamite garrison would not hold if attacked by the Mois. Suddenly there was a crash and the sky seemed to split from one end to the other. I was dazed by the light. The heavens opened and a storm of such magnitude as I had never conceived broke upon us. The current had to be turned off and there we sat in total darkness hour after hour, helpless and unable to use the instruments before us. Never have I seen such flashes of lightning, such blasts of wind and rain. The signal soldiers reported that no answer from the surveying party had been seen and the searchlight was now useless. I ordered a number of barrels of crude oil to be set afire as help must be had. The Annamite said that electrical storms sometimes kept up for several days and I trembled when I thought that I might be prevented from soliciting help by radio. It was simply up to Providence, and we kept up our ominous vigil, hoping and praying that the storm would cease at the break of day.

The girl came in to inquire for the lieutenant.

I sent her away with some excuse. A few moments later the Annamite called my attention to the East where the first signs of day were struggling through the storm. There came a blow at the door and a torn and water-soaked figure fell into the room. It was Gobert's soldier, who had struggled several miles through the storm and jungle. His condition was pitiful. After a breathing spell, he was able to tell us between gasps of terror and exhaustion that the lieutenant and his soldiers had been seized by the Moi chief. The soldiers were to be thrown to the elephants and the lieutenant, owing to his rank, would receive the more honorable death of being tied to four elephants which would then be driven to the four opposite points of the compass.

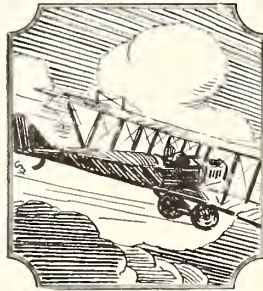

A scream followed and Pocahontas, who had been concealed behind the door, rushed into the room. She cried that she had saved Lieutenant Gobert once and she could do it again. Accord-

ing to the custom of her people all executions took place at high noon, and by starting at once she could forestall the event. I told her that I would not allow her to go as her father had vowed to kill her if she ever returned to his camp. The poor girl rushed from the room crying that she would gladly give her life if she could but save the lieutenant. It was necessary to have the girl locked up, and she struggled and shrieked to the very last.

I took up my place at the instrument again. The day broke with a rush, sending the storm away as fast as it had come. It was incredible that such a calm could succeed the crashes and downpour of the night so suddenly. I turned on the current and sent out the call for Qui Nhon, one thing running through my mind again and again—assistance had to arrive before noon. It was an hour before Qui Nhon was scheduled to receive but I prayed that somehow the message would be heard. A half hour went by. And then it was three quarters. My wrist watch showed that there remained barely five hours. I wondered what could be done if I could not get immediate help. It was impossible to rescue Gobert with the small detachment at the post. The poor Annamite was no longer capable of work; he was almost paralyzed with terror and I must admit the situation was affecting my own nerves.



Suddenly there came a buzz in my ears and a moment later I was pounding off the news of our predicament. Then I had to wait for a reply. An hour went by. Only four more hours remained. I cursed the slowness of officialdom. Finally, there came orders to get everything in readiness to receive two aeroplanes that had already started. I announced the news to the nervous Annamites and discipline returned immediately.

Then began the longest wait I have ever known. My eyes went from my watch to the eastern sky. Only two and a half hours remained. Duquesne flashed me words of encouragement. An Annamite rushed in pointing to the sky and words fail to express the joy with which we watched the progress and landing of the planes.

A Captain rushed forward and in a second I had explained the situation. He commanded me to enter his machine, which was a three-seated bomber, and we were off, followed by the small plane armed with a machine-gun, speeding for the Moi village. As we approached it, we could see a crowd in the square. We dropped a bomb which went off with a terrific crash as it struck the earth. The Moïs seemed to disappear into thin air. The small plane made a nose dive, spraying the fleeing natives. We exploded another bomb just for effect and

then landed, the small plane circling overhead to protect us.

We found Lieutenant Gobert and the Annamites lying in a row, stripped of their clothing and tied to thick bamboo poles. A Moi cart was found and we were soon on our way back to the fort. When we were safely within the walls, the two planes left for Qui Nhon, for the Moïs must be kept in fear of them. We were also told that reinforcements were on the way, and were also greeted upon our return by the surveying party that had seen our signal of the night before.

The joy of Pocahontas upon seeing her master was something I shall never forget. Savage though she may have been, she was as brave and devoted as they make them. That night, as Gobert and I communicated with Duquesne, it was with a sense of gratitude that we handled the small radio set. Twice it had saved the life of the lieutenant and his tiny garrison. As for me, I had to return to Qui Nhon contented with my one shoot, for I had so roused the natives that it was impossible to continue the hunt.

Now, as I sit comfortably by my radio set in a staid city of the United States, I cannot help wondering how Gobert and Pocahontas are faring in their fort in the wilds of the Moi country.

#### COOLING OFF AFTER A TIGER HUNT



# Adding Two Steps to Your Aeriola Senior

How the Job is Done, and What the Set Will Do

By JACQUES H. HERTS

**T**HERE must be a great number of radio enthusiasts who started their radio education as I did, with the well known Westinghouse Aeriola Senior, really the first of the WD-11 tube sets. To all of these this description of its reconstruction should prove interesting.

I acquired my Senior last April, and from the first hour that I had it in operation I knew that I had been bitten by the "bug." Results were interesting from the start and after a few months I was listening to half the continent on its single (and then almost unknown) WD-11 dry-cell tube. Being a "bug," I knew that ere long I should want a larger and more powerful set, and my present set is the result.

Several months ago the two-step audio-frequency amplifier to match the Senior made its appearance on the market; but my old Senior was rather shabby looking after its hard summer's work (though it still was reaching out 1,000 miles with regularity), and I didn't like the idea of hooking-up one of these nice, new shiny amplifying units to it, so I decided to use what I could from the Senior and build an

addition to it of two stages of audio-frequency amplification, the entire new set to be contained in one cabinet and, of course, to operate entirely on WD-11 tubes.

Not having the necessary equipment to do the work, I drew many plans and had them carried out by a well-known radio construction firm; however, the work is quite simple and could be done at home in a few days (and quite a bit of money could be saved on the job).

The new parts needed and their prices are as follows:

2 WD-11 tubes . . . . .	\$13.00
2 Transformers . . . . .	10.00
3 Sockets . . . . .	1.50
3 Rheostats . . . . .	1.80
3 Jacks . . . . .	3.00
3 Dials . . . . .	1.50
1 Variable Condenser . . . . .	2.50
3 Dry cells . . . . .	1.00
90 Volts of "B" batteries . . . . .	5.00
Panel (7x24) and Cabinet . . . . .	6.00
Sundries—Buss Bar, Spaghetti, Binding posts, etc. . . . .	2.00
<b>Total . . . . .</b>	<b>\$47.30</b>



FIG. 1

This is the receiver built according to the author's plan. Everything but the antenna and ground leads and the loud speaker (or phones) is within the cabinet. This receiver is both attractive and practical



The prices given are approximate. If you want to shop around a bit, you can reduce them materially.

You will note that I specify two new tubes,

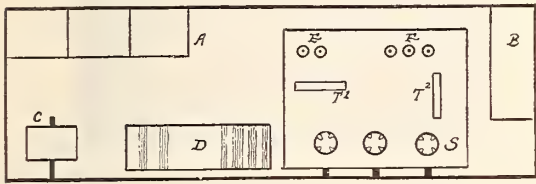

FIG. 2

There is plenty of room within the cabinet for the A and B batteries as well as the tuning and amplifying units. Note that the amplifying transformers are mounted at right angles to each other

assuming that you will use the one that you are using with your Senior, as I did. Three new sockets and rheostats are needed as the ones on the Senior will not be suitable for your new set. Choose dials and rheostats that match up and your new panel will present a neat, professional appearance.

I retained intact the Senior tuning element as I considered that the heart of the circuit, the only addition being the .0005 variable condenser in the antenna circuit instead of the fixed antenna condenser that is provided in the Senior. This gives considerably sharper tuning with better selectivity resulting. That's about all you can use of the Senior with the exception of the phone condenser and grid condenser and

leak, but it is enough to form the basis of a very fine piece of apparatus.

I used De Forest transformers and find the results excellent, though that is a matter of personal choice. Nearly any of the standard, well made audio transformers may be used with the WD-11 tube.

Figure 1 shows the panel arrangement. The .0005 condenser is placed at the extreme left, next comes the dial for the main variometer, and next the tickler. You will note that this arrangement reverses that on the Senior. It is done simply by turning the entire tuning element upside down. This will make wiring somewhat easier and is a bit better when you come to tuning the set. To the right of the panel you see the three rheostat knobs with the three jacks underneath for plugging in on signals with either the detector alone or with one or two stages of amplification.

Figure 2 shows the interior arrangement of the parts. I have my three tube sockets, two transformers and all battery binding posts, mounted on a small hard rubber base panel to the right of the tuning elements. I had my cabinet made large enough to hold three standard dry cells, comprising my A battery and one 45-volt B battery, although I find somewhat louder signals may be had by using 67½ or even 90 volts on the plates of the amplifying tubes, so I am using another 45-volt B battery for which there is not room within the cabinet. All connections are inside the cabinet with the

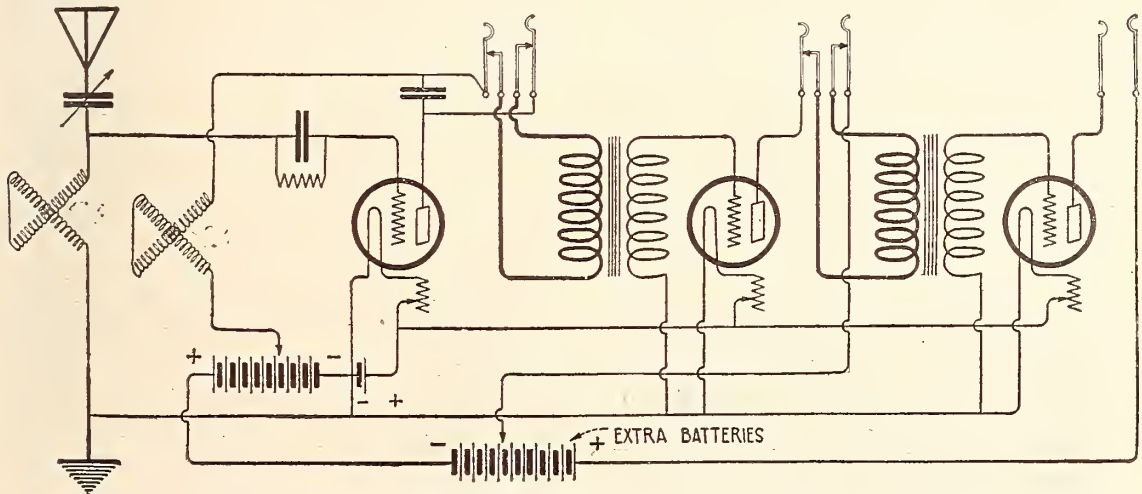

FIG. 3

The two variometers are included in the Aeriola Senior unit itself, and the addition of the variable condenser and amplifying units is clearly shown in this diagram

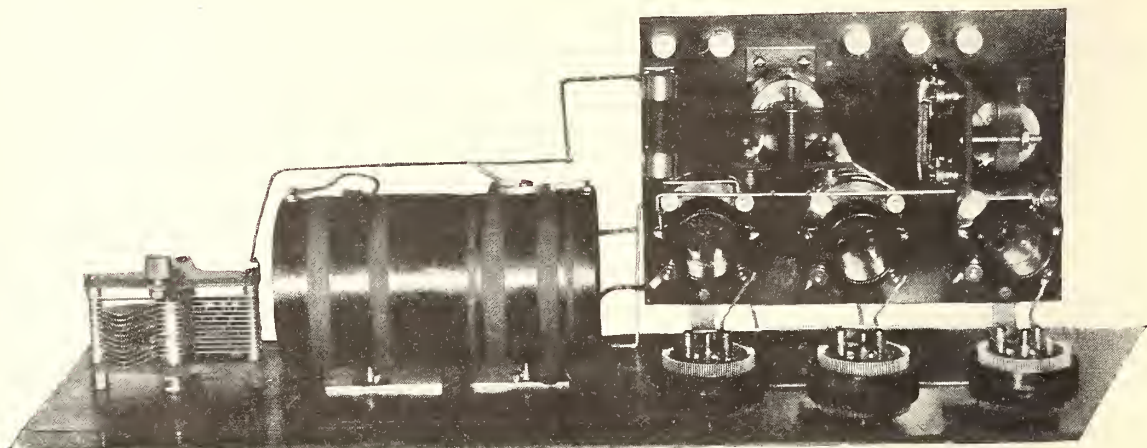

FIG. 4

Here we have the layout of the main and amplifier panels. Notice the shielding, made of sheet metal, on the main panel, and the sturdy brackets used to fasten the two panels together. All the binding posts are located on the amplifier panel

exception of this extra B battery and the silk-covered antenna lead and ground lead. The wiring diagram shown in Fig. 3, together with the panel and arrangement drawings, should enable any one to duplicate this set. So much for how it is done.

Now for what it will do. My outside antenna is a single wire 70 feet long on the top of a seven-story building with the lead-in to my room on the third floor. The ground connection is eight feet long to the cold-water pipe. I also use a loop aerial consisting of 15 turns of Litzendraht wire spaced  $\frac{3}{4}$ " between turns on a two-foot loop. I have used a Dubilier socket as an aerial with excellent results.

I list, in the order of their importance to me, the set's various performances:

**TONE QUALITY:** Excellent, equal to the best phonograph I have ever heard.

**SELECTIVITY:** I have readily tuned in (from New York) KYW, WWJ, KDKA, and WGY, while either WJZ, WEA, WHN, or WOR were going full blast.

**VOLUME:** Set can be heard all over our eight-room apartment. Local stations come in loud enough to work a non-power loud speaker, *using the loop*. This is one feature that appeals to me particularly, as the loop certainly tunes sharp and clean and when the summer season comes again should prove very useful in cutting down the static.

**DX:** My best distance so far is WBAP at Fort Worth, Tex., 1,400 miles, air line. I can probably improve this as I continue to use the set, but do not expect any tremendous increase in range over the Senior. Only the first stage of the audio amplification will be of any value in reaching out after DX stations and this assistance will only be slight.

The advantages of the set are, that the simple tuning of the Senior is retained to a large degree, the added control of the variable condenser does not complicate tuning very much (after a few days you will hardly notice the change), you still have a portable set (no storage batteries), and you have fine tone and ample volume, fine selectivity and good range.

Just one little hint. I found after a few weeks' operation and experiment that a .0005 fixed condenser shunted across the secondary of the second transformer improved the tone quite a bit and did not cut down the volume noticeably.

I have purposely avoided laying down any hard and fast directions or instructions for the construction work. I am merely offering a suggestion of what can be done with an Aeriola Senior and am leaving details to each individual's ingenuity. The next person that attempts the same job will probably hit upon some little wrinkle or improvement that I did not discover.



# What Can Be Patented?

By ROGER SHERMAN HOAR, A. B., M. A., LL. B.

Former Assistant Attorney General of Massachusetts

Drawings by THOMAS E. MONROE

**N**OT every bright idea is patentable, and not every patentable idea can be made use of by its originator. Without any further introduction, let us roll up our sleeves and plunge right into the following welter of words:

U. S. Revised Statutes, Title LX, Sec. 4886. Any person who has invented or discovered any new and useful art, machine, manufacture, or composition of matter, or any new and useful improvements thereof not known or used by others in this country before his invention or discovery thereof, and not patented or described in any printed publication in this or any foreign country before his invention or discovery thereof, or more than two years prior to his application, and not in public use or on sale in this country for more than two years prior to his application, unless the same is proved to have been abandoned, may, upon payment of the fees required by law, and other due proceeding had, obtain a patent therefor.

That is a mouthful, to chew and digest! But the present chapter will undertake that task. Let us start with a few definitions.

An "art" means some distinct method or process. The word "machine" requires no defining. A "composition of matter" consists in the uniting of two or more ingredients, either chemically or physically, to produce a new and homogeneous mass. A "manufacture" is anything, made by man, which is not a machine, a composition of matter, or a design.

The invention must be new and useful. Novelty consists in the invention not having been used by others in the United States, or patented or described in any printed publication in this or any foreign country. Yet prior knowledge or use abroad, unknown to the inventor, does not prevent the invention from being "new," even if such foreign use was known in this country. This shows that, in spite of the language of the above-quoted statute, prior *knowledge* in this country does not prevent novelty; and we shall see later in this article that even prior *invention* in this country is not necessarily fatal.

An invention is "useful," if operable, and if

not frivolous, nor injurious to morals, health or good order.

The Patent Office has an interesting policy with respect to perpetual-motion machines, which of course are not operable, and hence are not useful, and hence are not patentable. Unfortunately it is impossible, by mere argument, to convince the inventor of perpetual motion that he is on the wrong track. So the Patent Office adds a little inducement to its argument, by sending a personal letter to the poor deluded scientist, offering him his choice of a rejection if he persists, or a return of his filing fee if he will be so good as to withdraw his application. This usually works.

Yet many ideas as weird and wild as perpetual motion are permitted to be patented. I know of one leading patent attorney who has a much-prized collection of some two hundred freak patents of this sort.

If you wish some light humorous reading, I suggest that you look at the *Official Gazette* of the Patent Office each week at your Public Library, or subscribe to it at five dollars a year from the Public Printer, Washington, D. C. In the first place, this magazine is, next to the *Congressional Record*, the leading funny-paper of America. In the second place, it will enable you to keep in touch with the progress which is being made in your own particular line. Some member of every engineering department should certainly be assigned the very entertaining job of reading the "O. G.," which very name is symbolic of the surprised joy he will experience.

But although the examiners of the Patent Office are too busy to head off the scores of absolutely absurd and unworkable devices which issue every year, yet they occasionally balance the record by rejecting some perfectly workable one. "If this be treason, make the most of it," as Patrick Henry once said. For example, a certain aiming device for big guns, which was developed during the late War, was thrice turned down by them with much sarcastic comment, in spite of the fact that it had been tested and approved by the

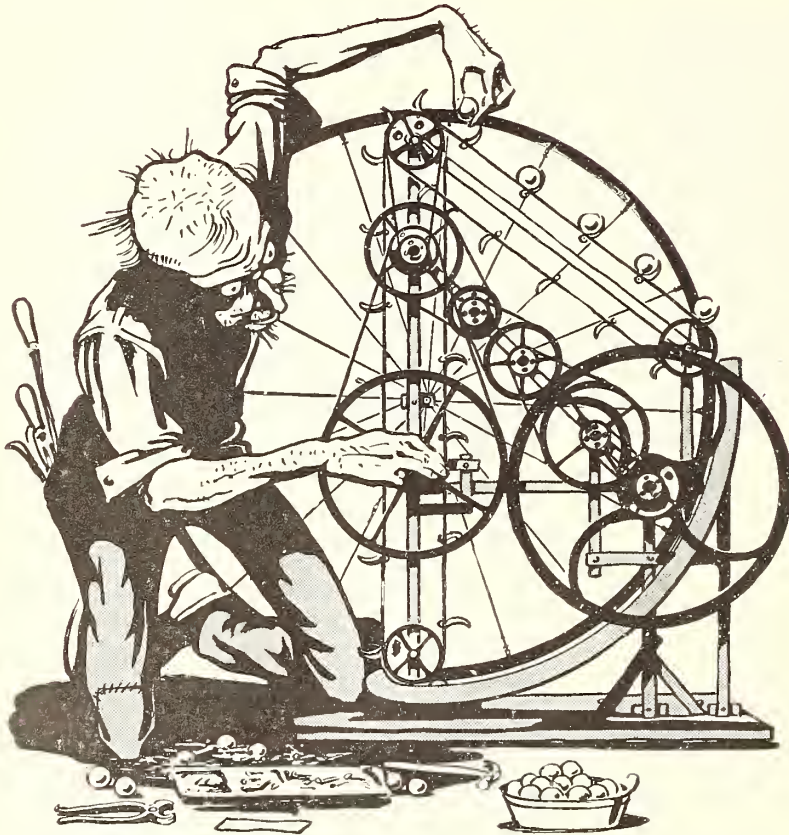

“INVENTION CONSISTS IN THE CONCEPTION OF A FUNCTION  
And the selection of means whereby the function can be operatively carried out”

Coast Artillery Board, the Field Artillery Board, the Chief Orientation Officer of the A. E. F., etc., etc., and had won an official U. S. Army contest to determine the most accurate device of its class. Yet the patent examiners thrice ruled, in the face of this evidence, that this machine could not possibly work!

Reverting to the subject of patentability, we find that there is an important legal distinction between “combinations” (which are patentable) and “aggregations” (which are not). Suppose your invention consists in putting together two or three already-known elements. The mere combining of old machine parts, each operating in the old way, and accomplishing the old result, is an aggregation, and hence unpatentable; whereas, if a new result be produced by the joint action of the elements, and if such result be not the mere adding together of the contributions of the separate elements, then there exists a patentable combination. Ask yourself: Is the function of the whole equal to, or greater than, the sum of the

functions of the parts? If equal to, then we have mere aggregation. If greater than, then we have combination. In other words, a patentable combination violates that fundamental axiom of geometry: “The whole is equal to the sum of its parts.”

Furthermore, a mere idea is not patentable; there must also be the means for utilizing it practically. Newly discovered laws of nature are not patentable; invention consists, not in discovering them, but rather in applying them to useful objects. A good definition from a very recent court decision is: “Invention consists in the conception of a function, and the selection of means whereby the function can be operatively carried out.”

Novelty and utility alone are not enough to make an idea patentable, but there must also be invention. That is to say, the inventor

must have displayed more ingenuity than could be expected of the average skilled person, when confronted with the same situation. It is not necessary, however, for the inventor to understand *why* his device works, provided he understands and explains *how* it works.

Mere simplicity of the device does not negate invention; but rather is often evidence of the very highest inventive genius. On the other hand, mere complexity or multiplicity of parts is no proof of invention. Redhoeffler's famous perpetual-motion machine attracted no popular attention until he added a lot of gears and buzzing ratchets, when it at once became a nine-day wonder; but all this noisy machinery didn't get him anywhere with the Patent Office. A certain gear company has an advertising machine consisting of about a thousand of their products, all intermeshing and actually running; certainly ingenious, and involving great mechanical skill, but by no means patentable.

A few further sorts of improvements which



are not patentable are: superior form or finish; a more extended application of an old idea; enlarging or strengthening; changing proportions; duplication of parts; changing the location of parts; substitution of equivalent materials; or substituting, for some part, a mechanical equivalent which performs the same functions in substantially the same way, thereby accomplishing substantially the same result. Mechanical devices are "equivalents" when any skilled and experienced workman would know that they would produce the same results.

The omission of a part and of its function is not invention; but the omission of a part, with a rearrangement of the remaining parts, so as to perform the same results, *is* invention. So likewise is the substitution of a single part to perform the functions of two or more former parts.

The best way to determine the patentability of your invention is to have some attorney make a search of the prior art in the files of the Patent Office at Washington. This will cost you at least twenty or thirty dollars, but any search costing less than this will not be worth even what you pay for it.

Thus it will be just as cheap for you to prepare a regular patent application and file it with a twenty-dollar fee, and then let the Patent Office make your search for you. If the search shows that your invention has been anticipated, it will have cost you no more than a search made by an attorney. If, however, the result of the search is favorable, your patent will already be on its way to allowance without further expense.

But, before doing even this, you can easily make a *sort* of search, which may be productive of great results at practically no cost. Copy the patent dates from a few machines of your own class. Look up the inventor's name and patent number under these dates in the bound volumes of the *Official Gazette* in the Public Library. If any of these inventions are at all like yours, send ten cents apiece, with the name, date and number, to Mentzel & Sterzer, 919 Washington Loan & Trust Bldg., Washington,

D. C., requesting copies of these patents, and a list of the patents which were cited against each, while pending. Enclose an extra dollar per patent, for this latter information. When they reply, send ten cents apiece for copies of the citations, etc., until finally you will have collected, at nominal cost, enough prior art to show you just where you stand. I always use this method.

You will save a lot of bother by using government coupons to order your copies. Such coupons can be purchased of the Patent Office in books of twenty for \$2.00, or one hundred for \$10.00.

Let us now consider how an invention can lapse. An inventor forfeits his invention by two years' public use or sale in America (by himself or others) prior to his applying for a patent; or by abandonment.

A single public use is sufficient. The knowledge or consent of the inventor is immaterial. But mere experimental use, even if public, is not a bar; and the Courts are very liberal in construing a use to be experimental.

A single sale is sufficient. Merely placing on sale the completed machine is sufficient, even if no sales result. But it is allowable to sell a very expensive *experimental* machine, without this barring your patent.

An inventor can likewise forfeit his invention by abandonment, as will be described in the next article.

Reverting to the language of the statute, you

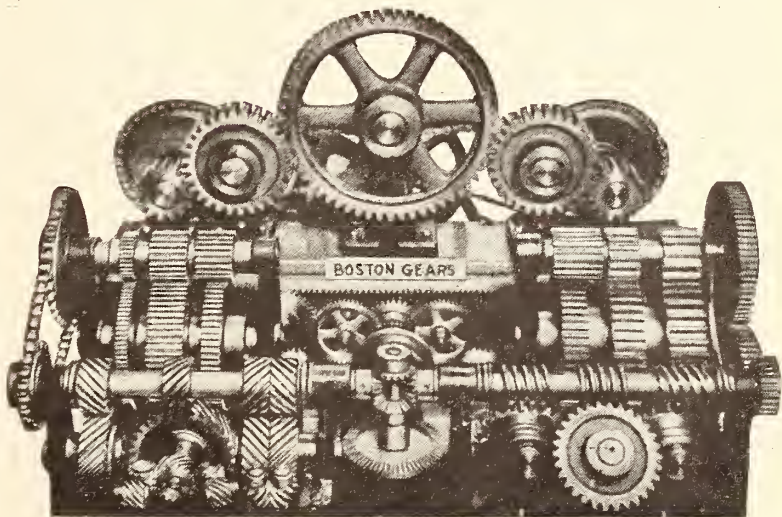

#### INGENIOUS, BUT NOT PATENTABLE

A collection of various kinds of products manufactured by a gear company. The gears actually run, but the machine serves no useful purpose



#### EVEN IF NO SALES RESULT

An inventor forfeits his invention by placing on sale his completed machine for two years prior to his applying for a patent

will see that only the inventor or discoverer is entitled to a patent in the United States. The manufacturer or first importer cannot get a patent here, although a different rule prevails in some foreign countries.

You will also see that the invention must not have been previously known or used by others. This amounts to the same thing as the statement to which the inventor must subscribe in his official oath: namely, that he is the original and sole inventor. Just what do these words mean? Strange as it may seem, they have two entirely distinct meanings, according as to whether the *real* first inventor does, or does not, apply for a patent. This is a vital distinction, and may well be the determining factor in deciding whether or not to apply for a patent.

Let me illustrate this point by the imaginary case of a certain type of desk invented by Smith. Suppose that Robinson, several months later than Smith, independently conceives of exactly the same invention.

Case 1. Suppose that both Smith and Robinson apply for patents. An interference is declared in the Patent Office, and each is required to produce evidence as to the date of conception of his invention, and the dates of

such subsequent acts as have been performed by him in completing, adapting, and perfecting it, and in putting it into use. Such dates usually include the dates of (a) conception, (b) first drawing, (c) first written description, (d) first disclosure to others, (e) first full-size machine, (f) first successful operation, and (g) first sale; also the extent of use. But, although the date of conception is the really important thing, it is very hard to prove a conception earlier than the date of first disclosure. Furthermore, the conception, drawing, description, and even disclosure are of no avail unless the invention was diligently reduced to practice, i. e., either built or embodied in a patent application. Reduction to practice will be discussed more at length in the next article.

Case 2. Suppose Robinson, the later inventor, applies for, and secures, a patent. Smith tries to manufacture. Robinson sues Smith for infringement. Smith defends on the ground that Robinson was not the original and first inventor, a defense specifically allowed by statute. But the Courts have cut down this defense by limiting the admissible evidence. Thus Smith must prove an actual successful use of the machine, or a sale or full published description, prior to Robinson's mere conception. Even proof of models and unpublished drawings will be of no avail to Smith.

Both cases show the importance of the real first inventor speedily applying for a patent, if he wishes to retain the right to manufacture his own device.

Let us now consider the perplexing question of joint inventors. If several persons work together devising a new piece of apparatus, which of them should be included in the application for a patent? This is not a mere formal question, but is very important, for a patent issued to two parties is invalid if one of them is the sole inventor, and a patent issued to only one of two joint inventors is likewise void.

This is particularly important in interferences where the true facts are almost certain to be brought out in the course of proving the date of invention. It is impossible either to add or to strike out an inventor by amendment; and so, because of including too many or too few names, the application is apt to be disregarded, and priority awarded to inventors who, although later, have nevertheless been more careful in this particular.

Above all, do not include the name of your



chief engineer, out of mere courtesy, as a joint-inventor, nor the name of your draughtsman or mechanic. I have known patents to be declared void for each of these causes.

If different improvements on the same machine are invented by each of several inventors separately without consultation with the other, then each must patent his own contribution separately. But mutual suggestions and improvements constitute a joint invention, even if the contribution made by each is distinct and separate.

Thus when a claim covers a series of steps or a number of elements in a combination, the invention may be joint, even if some of the steps or elements were contributed by one inventor alone.

On the other hand, the suggestion of some features by another than the patentee will not invalidate the patent, if the final result represents the patentee's own combination of these suggestions with ideas of his own.

In view of this, it may be desirable to patent a device in the name of the last contributor; and this is perfectly allowable if the device with his last contribution would be patentable as an improvement over the device as it stood just before this contribution.

Lack of mechanical skill, and the consequent employment of another to work out the details of your invention, do not prevent you from being the sole inventor.

In the absence of an express agreement between the joint owners of a patent, either of the owners can make, use, and sell the invention, or grant to others the right to do so, without regard to the proportionate interest which the parties may own, and without liability to his co-owners to share his profits with them.

As between patent attorney and client, any suggestions of the attorney inure to the benefit

of the client. In a recent case the lawyer claimed to have made a certain invention before his client came to him with the same idea; but the Court awarded the patent to the client. This illustrates the need of care in choosing an honest lawyer, a point which will be further discussed in the fourth article.

In the absence of an express agreement, an employer has no right to the inventions of an employee, even though the device was built, tested, and patented at the employer's expense, and even though the employee was hired expressly to invent, in which latter case, however, the Company would have an implied license to make, use, and sell devices embodying the inventions. And in any event, if the invention was applicable to the employer's business, he would have a right to use the device in his own shops.

Accordingly it is customary for employers to insist that technical employees shall agree in writing to assign all inventions made during their employment; and such agreements have always been sustained by the Courts.

An agreement to assign *all* future inventions, is void; but, with a time limit or even a limit to a certain class of inventions, it is perfectly valid. Yet everyone will tell you that there must be a time limit too, even in the latter case.

In my old home town, the noble redskins frequently sell a piece of land and still think that they own it. This results in the same piece of land being sold several times in succession, and yet still being claimed by its original Indian owner, to the great joy of some local lawyer. Hence the expression "Indian Giver." Somewhat the same idea frequently prevails among inventors, so let me state in closing that, if you sell a patent, it is *gone*, and even *you* can't manufacture your own device any more.

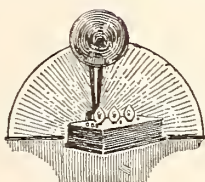

*This is the second of a series of four articles dealing with patents. The first, "What Good is a Patent?" appeared last month, and Mr. Hoar's third article, entitled "Protecting Your Invention," will be published in RADIO BROADCAST for June.—THE EDITOR.*



**LISTENING TO A BROADCASTING PROGRAM—**

This is said to be the first hotel in America to equip its—  
guests may listen when they wish to, but are not disturbed—





—AT THE HOTEL BELLEVUE, SAN FRANCISCO  
—dining-room with radio. By using individual phones, the  
—by a loud speaker when they prefer to talk—or eat!



# A Radio Code With Eleven Million Variations

By S. R. WINTERS

**W**HEN the battleship fleets of the Atlantic and Pacific engaged in maneuvers in the vicinity of the Panama Canal, in March, there was in operation for the first time under service conditions an apparatus for transmitting radiotelegraph messages in a code capable of 11,881,376 variations. The invention, the work of Edward H. Hebern of Oakland, California, is said to be the only one in the world by which wireless communications can be sent by a code system that is automatically deciphered and is clothed in absolute secrecy. A reward of \$5,000, offered to the Department of Justice many months ago, contingent upon its ability to decipher a message thus transmitted, has not been redeemed.

This machine, for which more than seventy patents have been issued or are pending in all countries of the world, functions in conjunction with a small, changeable wheel known as the "key wheel" or "code wheel." A statistical wizard in California has computed the possible changes to which one code wheel is subject as approaching the staggering figures—40,303,146,321,064,147,046,400,000. Be that as it may, this tiny wheel, weighing barely two ounces, contains a multiplicity of abbreviated electric wires—twenty-six, to be exact. In either side of this wheel are also twenty-six apertures, with an equal number in the rim.

Each key on the typewriter-like keyboard is wired in combination with other letters and they are responsive to a slight pressure of any of the letter keys, each of the latter being energized by an electro-magnet. The entire apparatus is electrically operated, the arrangement of the complicated wiring containing the secret of the instrument. A dry battery, half the size of one's hand, is sufficient to operate the machine for about two hours. The model on demonstration in Washington, D. C., employs a No. 750 Tungsten battery. As a matter of fact, any source of electricity is capable of operating this mechanism—a six-

volt automobile battery, dry cells, or direct or alternating current from a 110-volt home or office circuit. The standard code machine, however, is equipped for operation with alternating current, contact being made with a 110-volt circuit, which is "stepped down" to twenty volts by a transformer within the stand of the apparatus. If direct current is to be used, a special transformer is supplied for reducing the strength of the electric energy.

The operator who desires to transmit wireless messages according to this code system writes what he has to say in plain English on the keyboard. The code wheel on the sending device transforms the words into a jumble of letters, so to speak, for conveyance through the ether by radio. Both the sending and receiving units of this machine are combined, the entire outfit weighing barely twenty-five pounds and being less bulky than a typewriter.

The unit for the reception of the radiotelegraph communications records the words in code just as they were sent. However, the message is mechanically decoded before it is actually put down on paper by the receiving operator, who manipulates a keyboard according to the letters spelled out on an electrically-illuminated alphabet-board identical in arrangement with his keyboard. For the sake of convenience in transmission and as an extra precaution for insuring secrecy, the sending mechanism automatically prints the code in groups of five letters, and the decoding unit, at the wireless receiving station, converts these five-letter groups back into understandable English words.

The operator of the code receiving unit maintains on a rack in front of him a number of these spools or code wheels which correspond in wiring to similar wheels at the transmitting point. The operator who is to decode the message needs to know on which key letter the opposite wheel was set in order that he may set his wheel at the same key letter to start decoding. This is necessary since a wheel set at any one of the twenty-six key letters causes



the machine to write an entirely different code. Therefore, it is important either to print the key letter on which a code wheel starts coding as the first letter of the message, or to have it understood in advance what key letter will be used. Differently expressed, letters common to two wheels are first sent, which affords a "key" to the receiving operator to insert into his machine the similarly electrically-wired code wheel from his rack. That is, only two wheels that have electric wiring in common will function together.

The so-called "Hebern Electric-Super Code," to quote the inventor, "is merely the application of the electric current in certain combinations, which causes the machine at the receiving end to reproduce in understandable words an apparently meaningless, yet systematic, jumble of words sent out by the operator of the sending machine. Neither the sending nor the receiving operator knows the letters that are going through the air; that is the secret of the machine, or rather the secret of the two little, electrically synchronized wheels, a dozen of which can be carried in a man's coat pocket. The machine without the wheel is useless; the wheel without the machine is nothing but a little metal bobbin.

"To solve any one message sent out between any two of these machines and plucked from the air by wireless instruments, would require exactly 11,881,376 experiments, and it would require all the time of a staff of code experts for 100 years to make these experiments."

The "Hebern Electric-Super Code" is built in two units, one design being applicable to the service of the United States Government in times of war or peace, and the other provided with a typewriter and adaptable to commercial purposes. It is understood that the inventor will not sell these machines, but will lease them to interested parties. The machine is only

about 8 by 10 inches in dimensions and may be carried from place to place in a small case.

The protection of documents issued by banks, such as travelers' checks, drafts, cashiers' checks; the transmission of important business papers between banks or other commercial firms, and as a means of preventing forgery, are among the suggestions advanced for the application of this wonder-working mechanism to peace times. Somebody has stated that code messages sent during the Civil War have not yet been deciphered. Even as late as the World War the imperfection of code systems was realized when during the naval engagement off Jutland the code system was abandoned after a trial of one hour and messages received during that brief sixty minutes were not deciphered for days thereafter. The use of radio and the invention here described may solve the problem of the United States in the event of future wars, when a secret and yet readily understandable code system is a pressing need.

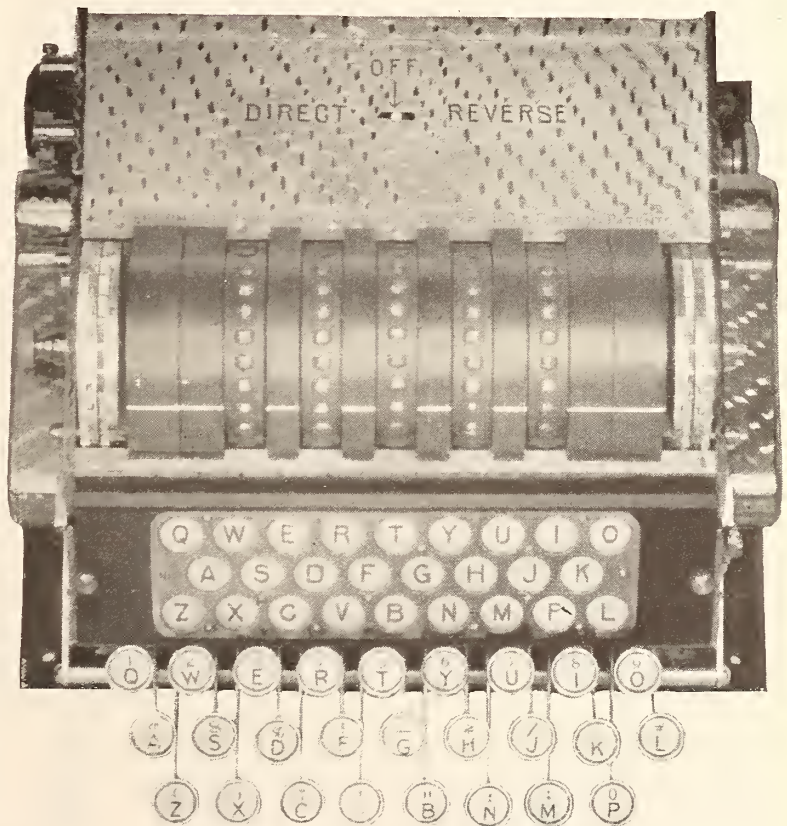

THE HEBERN ELECTRIC-SUPER CODE MACHINE





THE 2ND DISTRICT AMATEURS' 1923 BANQUET AT THE HOTEL PENNSYLVANIA, NEW YORK CITY  
Among the notables from "Hamdom" were Hiram Percy Maxim, Paul F. Godley, K. B. Warner and many of the amateurs whose signals had been received in Europe. Two of them had accomplished this feat with ten-watt transmitters



## Among the "Hams"



OFFICERS AND MEMBERS OF THE MILWAUKEE AMATEURS' RADIO CLUB

Beer may have put Milwaukee on the map, but this organization is doing its best to keep it there. Founded in 1917, the Club has had a steady growth, and its "ham-fest", technical lectures, spirited debates, and operating activities have evidenced a high degree of interest and enthusiasm among the forty-odd members. Meetings are held weekly, at which visitors and prospective members are welcome, and the Club is always ready to help the newcomer by teaching him the code and enlarging his acquaintance among radio amateurs



AMATEURS TAKING THE CODE TEST AT THE HOTEL PENNSYLVANIA, NEW YORK

This receiving contest, held to determine the fastest operator in the Second District, is an important feature at each annual convention

# All Boy Scouts, Attention!

*RADIO BROADCAST announces a contest, starting now and ending July 31, 1923, to determine WHAT BOY SCOUT TROOP HAS DONE OR IS DOING THE MOST WITH RADIO.*

## Prizes for Winning Articles

**FIRST PRIZE: CROSLY MODEL X 4-TUBE RECEIVER.**

*This receiver, which may be used with dry-cell tubes if desired, consists of detector, one stage of tuned radio-frequency and two stages of audio-frequency amplification. (Advertised in RADIO BROADCAST).*

**SECOND PRIZE: MUSIC MASTER LOUD SPEAKER.**

*This is the new loud speaker made by the General Radio Corporation. (A picture and description of it appear in the advertising pages of*

**THIRD PRIZE: THREE**

*The WD-11 is the well-known dry-*

*A YEAR'S SUBSCRIPTION TO*

*These prizes will be awarded to*



**WD-11 VACUUM TUBES.**

*cell tube manufactured for the Radio plate voltage 22½—45).*

*"RADIO BROADCAST" will be*

*troops, not to individuals, although any*

## Rules of the Contest

1. *Articles must be true accounts of radio with relation to your particular troop: what you have done, or are doing, or both.*
2. *Every article must be written by a Scout or by more than one Scout belonging to one troop.*
3. *Articles should be between 500 and 1000 words long.*
4. *Good photographs to illustrate the article will count 50% in judging contributions.*
5. *Typewritten manuscript, double-spaced, is desired, though not required.*
6. *Address contributions to Scout Contest, Radio Broadcast, Doubleday, Page & Company, Garden City, N. Y.*

*Scouts have done splendid work in maintaining communication by radio in time of floods and disaster, in copying and spreading the market reports transmitted by the government Farm Bureaus, in training themselves along mechanical and electrical lines, and, in short, in using radio as a part of scout work in a way consistent with the best traditions of scouting. What have you to tell of your troop's past or present activities? Get your scribes and photographers under way with that story which will put in a strong bid for first prize. How would a receiver with three stages of amplification go in your troop?*

*Beginning with the July number of RADIO BROADCAST, the best articles will be published. The winners will be announced in the September number, and unless the three best articles have been previously published, they will appear in that issue.*

## Wanted—Information on Railroad Radio

The Committee on Application of Radio to Moving Trains of the Association of Railway Electrical Engineers desires to communicate with any one who can give information regarding actual experiments in radio reception or transmission to or from a moving train.

Kindly communicate with the Chairman of the Committee,

Mr. P. S. Westcott,  
Assistant Car-Lighting Engineer,  
Chicago, Milwaukee & St. Paul Ry. Company,  
West Milwaukee Shops, Milwaukee, Wisconsin



# Why Life is Interesting to a Commercial Operator

Amusement, Experience and Education Come in Daily Doses to the Sea-Going Radioist, as this True Story of Three Trips on a Passenger Vessel Discloses

By A. HENRY

CAN you imagine being eighteen years old and having sailed as Chief Radio Operator and sending out an SOS and being rescued and written up in your hometown paper without noticing that the size of your hat was entirely too small? If you can't you will never appreciate my feelings for the week following my return from my first trip to sea. If, on the other hand, you can imagine the self-sufficiency such a series of events is likely to leave in their wake, you can understand my air castles.

And what is more, my pockets were well lined with real shekels and it was anything but difficult to engage the company of ladies fair, who, but a short month before would have refused my invitations with alacrity if not disdain. Few among them can resist the possibilities of association with a front page head-liner. Probably because news in our town was scarce at the time, much space was devoted to somewhat extravagant stories of my heroic deeds upon the sea. Because there was really nothing much for me to tell reporters, they spun great yarns about modesty in the usual way. But, you may wonder why you are told of these very natural and uninteresting details, and my only excuse is that I would like you to have some faint idea of my feelings upon being called upon the carpet in the holy of holies over which the Superintendent presided. You see, a week of pampering had almost completely altered my viewpoint of life and the satisfaction of being the centre of attraction

in a small town was an entirely new and not unpleasant sensation.

I was waiting in the "static room", which, a few years ago, was the ante-chamber to the offices of the Marconi Wireless Telegraph Company of America, where incoming and outgoing radio men gathered and swapped stories of true and imaginary escapades in foreign lands, while waiting a summons to appear before the Superintendent for assignment, re-assignment, or—the "gate." Just above the door leading into that gentleman's private office a buzzer hung from a screw, and it was connected by a wire system running into the "Super's" office, the repair department and the radio instructor's office. The gentry in charge of affairs found

## Life on the Ocean Wave

This is the third of a series of articles dealing with Radio Operating As a Career. The first article of the series appeared in our March number.

These stories are true and are actually chapters from the life of the author himself, who has been through the mill.

Next month, Mr. Henry is going to tell of his experiences on a private yacht which kept him in Mexico for five months. Among other interesting incidents he describes an attack upon the yacht by Mexicans, who attempted to put the radio equipment out of business by doing away with the operator.—THE EDITOR.

this means of communicating between their offices quite valuable; and the buzzer also served to call the desired operators to the desk of the "Super."

Even the older operators who gathered in this ante-chamber had accepted me into their midst, for in order to impress them, I had told a rather laudatory story of my shipwreck experience in a casual manner designed to conceal the exaggeration. As one operator who had just returned from Yucatan and Vera Cruz on the *Esperanza*, of the Ward Line, finished a tale concerning the embarrassing situations he encountered in attempting a courtship with a lady whose language he could not savvy and the mirth of his auditors was reaching a climax, the buzzer above the door grunted the symbols which spelled my name and with a

knowing wink I left the group and went into the office.

On reaching a point just in front of the boss's desk, I stopped and maintained a respectful silence until he had finished the very serious and laborious task of affixing his signature to a letter. Without looking up he proceeded to talk to me and read over another letter simultaneously. At least here was a man who was not very much concerned with my heroic exploit of a few weeks ago, and if his attitude was a little disconcerting, his remarks were even more so.

"Henry," he said, "you are to be promoted—". Following a slight pause, he looked up and a partial smile crossed his face, but he became serious and most matter-of-fact as he proceeded. "Yes, we're satisfied with your work and I'm going to assign you to a passenger vessel. You are to sail the day after to-morrow at three. Here's your assignment."

I was greatly pleased and said so and was about to withdraw when he cleared his throat and, after a certain amount of hemming and hawing, told me that my promotion was from a tug to a passenger vessel but my short time in the company's service did not warrant an increase in salary. Further explanation disclosed the fact that my youth would not permit my assignment as chief operator, but my salary would stand without reduction despite my sailing as junior. By the time he had finished I knew that he had outgeneralled me in a very thorough manner and I made a rather embarrassed departure. Since then I have often wondered why that suave gentleman wasted his time in a position such as his, when he could have made a fortune selling oil stock or gold bricks.

At any rate I was assigned to one of the Clyde Line steamers which plied between New York, Charleston, S. C., and Jacksonville, Fla. The day before we sailed I took my bags over, handed my assignment to the Chief Officer because the Captain was not aboard, and met the chief operator. He seemed a good sort but he was one of those uncommunicative fellows who mind their own business and show no desire to have any but strictly business relations with subordinates. He proved to be a very reasonable and just fellow—but he gave me a pain. We shared an inside room in the after section of the saloon deck just above the propeller and

hard by the men's wash-room. Steamship companies are always very solicitous for the comfort of the radio men that way. They know that the vibration is a sleep producer and that it is very interesting and entertaining on rough nights to hear the slamming of the wash-room door as landlubbers rush from their bunks in a never ending procession.

The radio shack was on the promenade deck just abaft the main stack and directly above the galley. We never suffered from the cold, especially when we got below Hatteras and the tropical calms settled upon us. We were saved the anxiety caused by not knowing what to expect on the menu, for the appetizing aroma of onion soup and similar delicacies was ever present in our little cabin.

Radio shacks are not large as a rule—ours was particularly small and must have been laid out by a past master at space conservation. There was a place for everything and one thing out of its place crowded the room beyond comprehension.

In addition to the radio equipment there was a typewriter and a multigraphing machine, used to prepare the radio news section of the little magazine we sold each day. And my chief, who happened to be a camera fiend, had a goodly store of film, printing paper, various chemicals in powder and liquid form, a red lantern and the usual coterie of trays, paper clips, etc. There was hardly room for us to sit down in comfort. There was no room at all for the radio equipment I brought along, so I made no reference to it, although I knew it would have improved the outfit greatly.

On sailing day I found a vantage point in the vicinity of the gang-plank and was agreeably surprised to note the number of attractive young ladies who made their way aboard. A feeling of superiority pervaded me and I paced the deck like a pouter pigeon, in an effort to engage the attention of some of the attractive maidens, but none of them seemed to heed me in the least, for how were they to know that I held the important post of Junior Radio Officer? I had no uniform and must have appeared to be one of those individuals who imagines that he is entirely sea-broken after a ferryboat ride or a sail in some yacht belonging to a friend twice removed.

Some of the ladies strolled about the deck and I went into the radio shack and acted as I





thought a sophisticated operator would act. For the benefit of several gentlemen who made it their business to stop at my door and ask questions, I unsheathed a bundle of technical terms, designed to fill them with awe, but when one of the group asked some questions that indicated quite plainly that his knowledge of radio was greater than my own, I recalled an important engagement elsewhere and closed shop to visit our sleeping quarters.

Here I found my chief laying out his uniform on my bunk and making ready to try a little slumber in his own. Assured that he would not bother me for a while I made my way back to the

operating room, swung the door wide open, removed my coat and started the motor-generator. Its hum attracted a few people, so I disconnected the aerial lead and began manipulating the key while the heavy spark boomed in its chamber. A crowd soon gathered outside the door, though I pretended to pay no attention. I made various adjustments and exercised all the meters, shut down the set and turned around to answer any questions which might be forthcoming.

A young lady, evidently with her mother, beamed upon me and asked about the wonders of wireless. She was most attractive and we chatted for some time and became quite friendly, though we had not reached the point where an exchange of names takes place. Here, indeed, was a stroke of rare luck. I made use of every device I could recall learning from the old-timers in the static room and my progress was so satisfactory that I was wondering how best to invite her to visit the shack occasionally on the trip south.

Suddenly there was a blood-curdling racket on the deck and it seemed to be coming in our direction. A colored porter bawled "All Ashore's Goin' Ashore" and accompanied himself by lambasting a metal tom-tom. My visitors dispersed and the attractive young



HARDLY IN KEEPING WITH MY AUGUST POSITION AS RADIO OFFICER  
Was my job of hawking the magazines we printed, at a dime a copy

lady thanked me for my kindness and departed. I took a position near the gang-plank and by the time that porter finished his parade most of the attractive ladies had made their way down the gang-plank and were waving tear-bedewed handkerchiefs to departing mothers, fathers, etc. Most of those remaining aboard seemed to be possessed of husbands and as we pulled out into the stream I resigned myself to my work and tried to forget the alluring possibilities of feminine companionship which had loomed up during the past hour.

As we left the dock I reported to the Sea Gate Station and was advised that there were no messages on hand for me, so I strolled around the deck a few times, stopping here and there to have a chat with the passengers. A group of young folks attracted my attention and I spent some little while discussing all manner of important events such as the time made in races at a college athletic meet and the possibility of bad weather after passing Scotland Lightship.

We sailed at three and it was not long before dinner time rolled around. My chief relieved me and I found my way into the main dining saloon, where some of the passengers had already gathered, and a rattle of dishes in the pantry proclaimed that service had started. A Negro



THE RADIO MAN'S DINNER TABLE IS LIKELY TO BE GRACED BY A COSMOPOLITAN GROUP

Consisting of a spoiled society bud, the heavily bejeweled wife of a newly 'arrived' pawn-broker, an English remittance man, and a lady who is "well-known in society." Often the peace of mind of everyone present is upset by the ill-bred youngster whose mother is more attentive to the men aboard than to her child

waiter whose smile disclosed two lines of ivory and gold ushered me to a seat, which was reserved for me. It was at a table some little distance from the Captain's, so I felt quite at home.

It is unlikely that any place in the world, even a railroad station, permits the study of so many different kinds of people as a steamship. One finds gentlemen who can eat peas only if served with mashed potatoes and who imagine that their discourses upon the latest scientific discoveries are amazingly interesting to their co-voyagers. One is likely as not to find at his table the wife of a newly "arrived" pawnbroker, heavily bejewelled and master of gestures accompanied by knife and fork; an English "remittance man" on his way to parts unknown; a society matron, whose dwindling fortune makes it increasingly difficult for her to keep up the pace her position demands, while very much in evidence is one of those ill-bred youngsters who delights

in spilling soup without regard to the direction it takes by yanking the table-cloth in a hair-raising fashion.

Following the evening meal among just such company I was to relieve my chief while he ate his dinner and, following that, I would retire until *one o'clock* the next morning. From one to eight was my section of the night watch and there was quite a bit of work to be attended to. Among other things it was necessary to print the radio section for the magazine we sold. The Chief copied the press reports from one of the coast stations and typed them while he was on duty. Our typewriter was provided with a duplicating ribbon, so it was but necessary for me to put the original in a duplicating machine and draw off as many copies as we estimated could be sold.

If there was any brass to shine or similar work to be done, the night watch was the time to do it, for it was difficult to remain awake. The monotony, however, could be broken by



an occasional trip to the officers' mess where coffee and stale sandwiches could be found.

In the morning the chief had his breakfast and then relieved me. When my breakfast was finished I took an armful of magazines and hawked them about the deck at a dime a copy. Being associate editor, reporter, printer and newsboy was interesting but it was hardly in keeping with the august position of the Radio Officer, and I began to cast about for a better selling system. By appointing young ladies to the positions of reporter, subscription and circulation manager, society reporter, etc., we were able to sell more copies with less effort and still maintain our dignity. Thus, instead of retiring at ten-thirty or eleven, it was possible for me to get to bed by nine or nine-thirty, though by that hour the extreme desire for sleep usually had passed and the few winks before lunch time amounted to little or nothing.

After we had been out two days on my first trip on this vessel, I happened to be in the lounge one afternoon, chatting with one of the "society editors," who was a very comely girl of some eighteen or twenty years. I was assisting her to dispose of a box of chocolates, when the Captain came in. Seeing us, he smiled and sat down with us, helping himself to the chocolates. Most of his remarks were addressed to the lady and he seemed to be enjoying himself quite well. As he was about to withdraw he invited us—I was included by a half-hearted attempt at politeness—to visit the pilot house where we could see the navigating instruments. He asked me if I was bound for Charleston or Jacksonville, and seemed somewhat nonplussed at my reply that I was going to both places and then back to New York. Somehow or another the subject of wireless was brought up and he passed some disparaging remarks about the system in general and operators in particular.

"Well, Captain," said the pretty society editor, "this young man must be somewhat different from most operators and I know you must like him."

"What's he got to do with it?"

And he had no sooner asked the question than his face began to go through a series of contortions as it dawned upon him that I was his junior operator. He departed before his wrath escaped, but it was not more than a few minutes later that a quartermaster told me of the Captain's desire to see me in his cabin.

Followed a lecture about ship's discipline during which it became very clear to me that none of my duties included the entertainment of the lady passengers—that task seemed to have been meted out exclusively to the Captain. Among other things, it was essential that I procure a uniform at once in order that the Captain might not again mistake me for a passenger and become the least bit friendly. Finally, my Chief was informed of my transgressions and advised to put my case in the hands of the superintendent upon our return to New York. Captains, as a rule, are strange that way. In their own opinion they are past masters at entertaining the ladies; but a radio shack has wonderfully romantic possibilities if properly engineered.

In this particular instance the "old man" made the mistake of inviting the young lady and her mother to lunch with him in his cabin and during the luncheon pointed out the folly of having anything to do with wireless operators. From his description, we were a bad lot and no fit company for young ladies. The result was that he finished his luncheon alone and we had a word for word report of the proceedings, which the ladies believed would make most interesting reading in our paper. That, of course, was out of the question.

Nothing of great moment happened before we arrived at Charleston, where my Chief took me in tow to point out the places of historic interest. A classmate of mine, who was on his way to Miami with his mother, came aboard and there was another lady in his party. As soon as we left the dock he brought her around to the radio shack and they had all sorts of good things to eat with them. A few minutes later our society editor arrived upon the scene and we had a very jolly little party.

It was but a step to the smoking room and we could have all sorts of pop. There were pickles and olives and ham and saltines and raspberry soda and the usual accessories for a college girl's dormitory escapade. Four of us were inside the room, one seated on the table; one on top of the tuner; one in the only chair and one on the door sill. Papers containing various edibles were strewn about wherever they could be pushed out of the way. One of the girls had a harmonica and she played some popular airs while we all sang or whistled or hummed. I was "on watch" and therefore could not



remove the headphones and dancing was out of the question in our little shack.

We had just finished the refrain of a popular musical number, executed with great gusto and stamping of feet, and were making another attack upon the food when the room was suddenly darkened. I lowered the pop bottle and was more than delighted to see the jolly old Captain standing in the doorway. He was delighted, too, for it seems that our singing had reached him, while he vainly sought slumber.

My guests were dispersed and the wrath of the master again descended upon my unholy head. I was a young fool—a pest—an insubordinate jackass—and a few other things uttered in sub-audible tones.

Next day we arrived in Jacksonville and my newly made friends kindly invited me to visit them, which I felt at perfect liberty to do. There were no "watches" to stand and I did

not put in my appearance aboard ship until a few hours before sailing. I had met the Captain, however, in the dining room of the Windsor Hotel and though he said nothing, he gave me a wicked look.

You see, one of the officers mentioned that the captain was a regular guest at the Windsor by courtesy of the management. Tales had been spun in the static room of similar arrangements extended to radio men in other ports. After a certain amount of argument, it was possible to convince the manager that we could direct a great number of guests to his establishment in return for a room with bath. This was indeed an achievement and a certain satisfaction was felt when we could ask correspondents to write us in care of the hotel. Well do I remember how astonished some of the passengers would be to find that we lived in a hotel while ashore. And the letters written on the hotel stationery sent to friends at home were designed to create an impression of progress in the world of commerce.

Upon arriving in New York, I felt rather doubtful about putting in an appearance at the office, but funds were not running very high and a few dollars would relieve some of the strain, so I fared forth. Quite to my surprise the Senior had turned in a favorable report with the single exception that the Captain objected to my sailing again without a uniform.

For the next three days I spent most of my spare time searching for a uniform at my price, but it was not to be had and the Superintendent was satisfied to have me make another trip provided I purchased a uniform cap. This I did, but the Captain was less easily satisfied and insisted that I could not leave on the third trip ununiformed, so once again my time in New York was spent hunting for proper raiment.

Eventually I was able to procure a suit from the Superintendent himself, who had undertaken to dispose of it for another operator. After he had seen to it that my shekels were delivered safely into his hand he informed me that the fellow who had previously owned the outfit had joined the angels following a contagious disease, but he assured me that the perfect fumigation through which the suit had passed made it quite unlikely that I would go and do likewise.



IT WAS AT LEAST A UNIFORM



# Broadcast Receiving Contest!

## Any Number of Tubes—Any Kind of Receiver

THE LONG-DISTANCE RECEIVING CONTEST, to determine who has done the best with ANY NUMBER OF TUBES AND ANY TYPE OF RECEIVER, is well under way. The drawbridge will be hauled up at sunset on May 31st, however, and after that even the most imposing-looking contributions will have to be left outside the portcullis. A great many of them will probably gallop through in a cloud of dust at the last minute—but that is dangerous business, and we advise you not to try it. Read through the Eight Commandments below, roll up your sleeves, and go to it.

### The Four Prizes

#### First Prize: DE FOREST D-7 REFLEX LOOP RECEIVER

This receiver, described in RADIO BROADCAST for February (page 207), is the latest product of the De Forest Company: it makes three amplifying tubes and a crystal detector do the work of six tubes. The loop antenna aids in selectivity because of its directional properties. An ordinary antenna and ground may be used, however, if desired. Recently, a man in Brooklyn, N. Y. heard a broadcasting station in Seattle, Wash., with one of these sets.

#### Second Prize: GREBE TUNED RADIO-FREQUENCY AMPLIFIER, TYPE "RORN"

Illustrated on page 352, RADIO BROADCAST for February. This amplifier, which has a wavelength range of from 150 to 3000 meters, may be used with any form of home-made or bought receiver. It is the most recent development of a company widely known for the excellence in design and workmanship of its products.

#### Third Prize: Choice of

THREE OF THE NEW RADIOTRON UV-201-A AMPLIFIER TUBES (6 volts,  $\frac{1}{4}$  of an ampere), or

THREE AERIOTRON WD-11 DRY CELL TUBES ( $1\frac{1}{2}$  volts,  $\frac{1}{4}$  of an ampere).

#### Fourth Prize: TIMMONS LOUD-SPEAKER UNIT

This unit, which may be connected directly to the output of your amplifier, has a diaphragm adjustable for sounds of different intensities, and when used with two stages of amplification reproduces broadcasted programs about as loud as the music from the average phonograph.

### Rules of the Contest

1. You should list all broadcasting stations 150 or more miles away from the receiving point, which you have heard distinctly (announcement of location as well as of call letters.)
2. Measure distances accurately, and give aggregate mileage. (This is the sum of all the distances, each station counted once, but two or more stations in the same city being counted separately.) An aggregate mileage of less than 15,000 miles will not be considered.
3. Manuscripts should include the following: description of set, directions or advice for constructing and operating it; any "wrinkles" or makeshifts which you have used to advantage; photograph of your apparatus; circuit diagram; in general, anything you have to tell that will make your story more interesting and helpful. Manuscripts should not be longer than 2000 words. Typewritten reports preferred.
4. Data should be arranged in three columns, under the headings: call letters, location, distance.
5. For material used, a liberal rate will be paid.
6. In judging contributions, the quality and interest of photographs, text, and drawings, and the originality and general effectiveness of the apparatus described, will have greater weight than the list of stations heard, although a long list of distant stations will distinctly help.
7. The Contest begins now and closes May 31st, 1923.
8. Address: Receiving Contest, RADIO BROADCAST, Doubleday, Page & Co., Garden City, N. Y.

# Six-Inch Dry Cells and WD-11 Tubes

By E. E. HORINE

National Carbon Company, Inc.

**F**OR more than twenty-five years the six-inch dry cell has been a popular source of small amounts of electrical energy. It is convenient, compact, safe, and reliable. It is in such

universal demand for a wide variety of purposes that it has become a staple article of commerce all over the country. It may be purchased for a small sum in any city, town, or village, and at most country cross-roads stores.

With such a cheap, convenient, reliable source of energy almost universally available, it is natural that designers of receiving vacuum tubes should bend their efforts toward the development of a tube which would be so economical of current that dry cells could be used for heating the filaments.

The WD-11 tube is the first among these tubes to have been developed and placed on the market. These dry cell tubes are proving popular, and deservedly so, for they are the means of bringing radio to rural sections where storage battery charging is a real problem. They also have a strong appeal for the city dweller, who, although surrounded by cheap current and storage battery charging stations, welcomes relief from the relatively large investment for a storage battery and its attendant bother. Dry battery tubes bid fair eventually to replace all storage battery receiving tubes; so a study of the characteristics of dry cells is of particular interest to the radio enthusiast.

The dry cell is inherently an intermittent service cell. That is, it must be given opportunity to recuperate between periods of service in order to use it most economically.

More work can be obtained from a dry cell by operating it intermittently than by drawing current from it continuously. Practically all radio receiving sets are operated for a few hours each day, standing idle the rest of the

time, which is an ideal arrangement from a dry battery standpoint.

The uses to which dry cells are put are so numerous, and the demands made upon them are so diversified, that it has been necessary to develop a number of different types of cells, each especially suited for some particular class of service. In addition to these so-called "single-purpose" cells, there has also been developed the "general-purpose" cell, de-

signed to cover a number of uses. This latter is the cell with which the public is most familiar, and is the one usually sold over the counter to the retail trade. It is generally used for motor ignition, bell ringing, annunciator systems, and lately for heating the filaments of vacuum tubes. Our discussion of dry battery characteristics refers only to this general-purpose battery.

When a radio enthusiast purchases a number of dry cells for his set, all he wishes to know about them is how much electrical energy he is getting for his money. However, he does not couch his inquiry in this style: he merely asks "How long will they last?" This is a reasonable and proper question, and on the face of it, a simple one. Yet, of all the questions he might have asked about dry cells, this is perhaps one of the most difficult to answer, the main reason being that the amount of service, measured in hours, obtainable from a dry cell, depends largely on the unknown

Since the Westinghouse Company brought out the WD-11 dry cell tube its use has become increasingly popular. There is no doubt that it is one of the most important forward steps made in receiving apparatus during the past few years. It has actually made radio a source of pleasure, information, and instruction for many who would never have availed themselves of it otherwise.

The satisfaction derived from a receiver employing one or more of these tubes depends in no small measure upon a suitable filament current supply. With this in mind we asked Mr. E. E. Horine, of the National Carbon Company, who has directed a great deal of research work in the application of dry cells to radio, to prepare this helpful data for our readers on this important subject.—THE EDITOR.



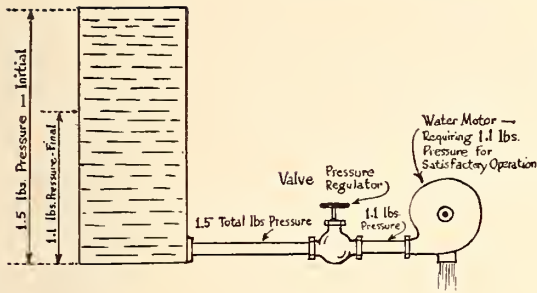

FIG. 1

factor of just how the cell is to be used. All the manufacturer can do is to see to it that his product contains the maximum amount of electrical energy when it leaves his hands. There his control over the cells ceases, and from that point on, the amount of service obtainable from them is strictly up to the user. In the hands of different people, identical cells will deliver widely divergent amounts of service.

If the exact conditions of service are known, it is quite easy to predict just how many hours of useful work may be obtained from an average dry cell. But conditions of service vary, even in radio work, and the best that can be done is to state how many hours of service should be obtained under certain different conditions.

In many ways, a dry cell may be compared to a tank of water. In Fig. 1 such a tank is shown connected to a water motor. The motor is so designed that it will not work if the water pressure falls below 1.1 pounds per square inch. The height of the tank is such that the resultant pressure when full is 1.5 pounds per square inch. To control the pressure applied to the motor, a valve which varies the resistance to the flow of water is inserted in the line between the tank and the motor.

As water is drawn from the tank, the level of water falls, and the pressure drops. After a certain definite amount of water has been withdrawn, the pressure reaches 1.1 pounds per square inch, following which the motor will fail to function due to lack of sufficient pressure. If the operator of this device fails to regulate the valve properly, so that at times the pressure on the motor is in excess of 1.1 pounds per square inch, the water will be drained out of the tank more rapidly, and the length of service down to the final 1.1 pounds, will be materially reduced.

The conditions in Fig. 2 are the same as in

Fig. 1, except that here we are dealing with a flow of electrical energy instead of water. The dry cell is the container of electrical energy. This energy is held under a pressure of 1.5 volts. The proper operating pressure for the WD-11 tube is 1.1 volts. The rheostat serves as a voltage regulator, and if properly manipulated, maintains the voltage on the tube constant at 1.1 volts.

As energy is drawn from the cell, the voltage gradually drops, and this decrease in voltage must be compensated for by adjusting the rheostat. Eventually the cell voltage falls to 1.1 volts, after which satisfactory operation will not be obtained, because it is no longer strong enough to heat the tube filament to a point where sufficient electron emission occurs. The lowest voltage at which a dry cell can satisfactorily supply current to any device is called the cut-off voltage. This figure varies for different electrical devices, and has a marked influence on the amount of service obtainable from a dry cell.

To obtain the desired characteristics, the designers of the WD-11 tube found it advisable to choose 1.1 volts as the operating voltage. This means a cut-off voltage of 1.1 volts for the dry cell used with it.

The current taken by the WD-11 tube at 1.1 volts is about one quarter ampere. Curve A, Fig. 3 shows the number of hours of service obtainable from a six-inch dry cell, delivering one quarter ampere, two hours per day, to various cut-off voltages. This curve, as well as others presented in this article, is the result of a large number of tests on several leading makes of general-purpose dry cells, and represents the average performance of the various makes, rather than the individual performance of any one make. These curves therefore show what the user may reasonably

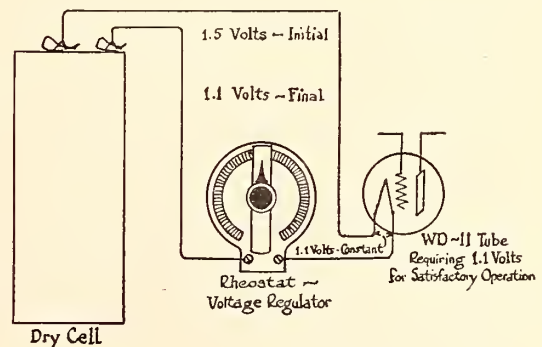

FIG. 2

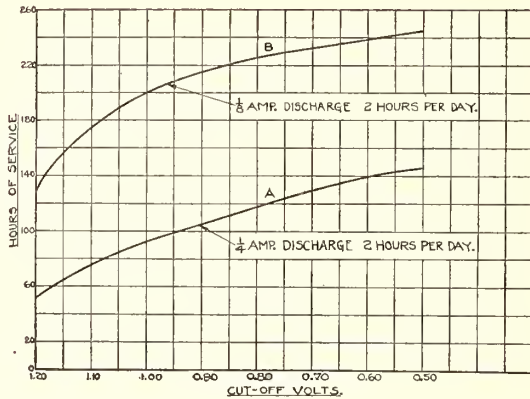

FIG. 3

By comparing curves A and B, the economy of using two dry cells in parallel (curve B) for each tube becomes apparent

expect from any dry cell of reliable manufacture, provided he uses it properly.

By exhausting the cell down to a cut-off of 1.1 volts, at the rate of one quarter ampere, two hours per day, the amount of service obtainable is approximately 75 hours.

Curve B, Fig. 3, shows the amount of service obtainable from a six-inch dry cell when delivering one eighth ampere two hours per day. This is the condition prevailing when two cells connected in multiple (zinc to zinc and carbon to carbon) are used to operate one WD-11 tube. Here the total current of one quarter ampere is divided between the two cells, so that the discharge from each is one eighth ampere. Under these conditions, the amount of service obtainable from the two cells is approximately 175 hours, or at the rate of  $87\frac{1}{2}$  hours per cell, instead of 75 hours, and at one twelfth ampere, it is 258 hours.

Fig. 4 shows the effect on service life of various rates of discharge. This curve was obtained by operating cells two hours per day to a cut-off of 1.1 volts at different currents. At discharges of one quarter ampere, the service life is 75 hours. At one eighth ampere, it is 175 hours, and at one twelfth ampere, it is 258 hours.

These discharge rates correspond to the use of one, two or three cells for each WD-11 tube in the set. The service for one cell is 75 hours; for two cells,  $87\frac{1}{2}$  hours per cell; and for three cells, 86 hours per cell. This shows that while it is more economical to use two cells per tube than one cell, no further increase in economy is obtained by using more than two cells per tube.

Still another factor affecting the service life of dry cells is the average number of hours the cells are used each day. In radio reception, this is an extremely variable factor, and no one knows just how many hours per day the average set is used. It probably lies between two and three hours a day, although individual cases will vary considerably from this figure.

The curves in Fig. 5 serve to show how different periods of use affect the service life of dry cells. Curve A is for one quarter ampere to a cut-off of 1.1 volts, and curve B is for one eighth ampere to the same cut-off point.

It will be observed from a study of Curve B that when the periods of use are below  $1\frac{1}{2}$  or 2 hours per day, the service life is slightly reduced. This is due to the natural depreciation which takes place in all dry cells when not in use. On the other hand, when the service periods are greater than three hours a day, the number of hours of useful life is again decreased, due to the lack of sufficient time between periods of use for complete recuperation. Between these two extremes is a point where maximum service will be obtained, and in this case, it is somewhere between two and three hours per day. For each current discharge, there is always this point of maximum service, but it is different for each current. For one quarter ampere discharge, maximum service will be obtained by using the cells between one half and one hour per day.

This further emphasizes the advisability of using two dry cells for each WD-11 tube in the set. When this is done, maximum service is obtained by operating the set two or three hours per day, and in all probability,

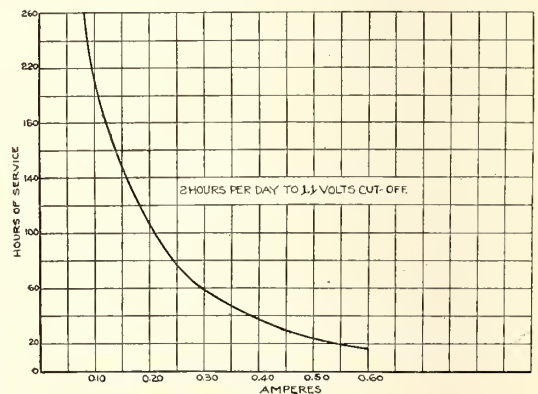

FIG. 4

It is evident that the less current you take from a dry cell the longer its life will be. However, it will deteriorate of its own accord from too little use, as shown in Fig. 5



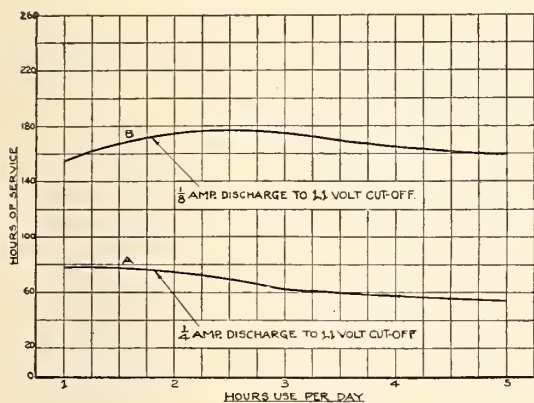

FIG. 5

Different periods of service may be expected where the amperage and the hours of service per day vary. By properly proportioning your cells to meet the demands of your particular service, you may secure the greatest life for your A battery at the least expenditure

this figure comes nearest to average conditions of use.

The age of a dry cell when put into use has some influence on the amount of service which can be obtained from it. The slow depreciation going on in all idle dry cells, has the effect of reducing the useful service life. However, in well-made cells, this depreciation factor does not become appreciable for many months. The date given in the curves, Figs. 3 to 5 apply to dry cells not more than six months old. The possibility of a purchaser securing a dry cell more than six months old is extremely remote, if he confines his purchases to cells of well-known, reliable make, for such cells enjoy a wide sale and consequently the dealer's stock turns over rapidly, insuring fresh cells always on hand.

Let us assume that the average user has purchased two standard six-inch dry cells for his WD-11 tube which he uses between two and three hours daily. Under these conditions he should obtain 175 hours of service from the battery, but he sometimes fails to do this by a considerable margin. On first thought he is apt to blame the dry cells. In the vast majority of cases this is unjust, because cells made by reliable manufacturers are not only carefully constructed, but are constantly inspected during process of manufacture and carefully tested before shipment. The chances for defective cells getting into the hands of the user are

practically zero. The failure to get adequate service is usually caused by the user himself. Just what does the operator do that shortens the life of his cells?

He may fail to adjust his filament rheostat properly. Suppose, in adjusting his rheostat, the operator obtains a current of 0.28 ampere instead of 0.25 ampere. This is easily possible, for the average operator has no means of accurately determining the filament current. By doing just this one little thing, he reduces the service life of his dry cells 25 hours, as shown in Figure. 4.

Some filament rheostats are responsible for decreased service life of dry cells. It may seem a far cry from a filament rheostat to dry battery life, but in reality the two are closely associated.

The construction of certain rheostats is such that it is impossible to cut out all the resistance. With the indicator at the "all out" position, there still remains a small amount of resistance in the circuit, which prevents the full battery voltage from reaching the tube. This voltage drop is always present, and means that the cut-off voltage of the cell must be greater than the tube voltage by an amount equal to the drop through the fixed resistance. Even if this resistance is so small as to cause a drop of only .05 volt, this will reduce the service life of the cells ten or twelve hours.

The resistance of the wires used to connect the battery to the tubes has a similar effect. Resistance measurement of typical installations have been made, and in some cases, the resultant voltage drop has been found to be as much as 1 volt. This immediately raises the cut-off point from 1.1 to 1.2 volts, with a corresponding decrease in battery service life of 45 hours.

To get maximum service from six-inch dry cells in connection with WD-11 tubes, the following should be observed:

Obtain fresh cells by purchasing those of reliable manufacture which enjoy a large sale.

Use two cells connected in multiple for each tube in the radio receiving set.

Never subject the tube to a voltage in excess of its rating, that is, 1.1 volts.

Install the battery so that there will be the minimum resistance in the leads between it and the tubes. Locate the battery as close as possible to the tubes, and use heavy wires for connections.

# Revised List of U. S. and Canadian Broadcasting Stations

This list includes all commercial broadcasting stations in the United States licensed up to March 18, 1923. \*denotes stations that were deleted up to that date. The Canadian list, comprising 59 stations, includes all that were licensed before February 21, 1923. Additional lists, with deletions, are printed every month in RADIO BROADCAST.

KACY	Western Union College	Le Mars, Iowa	KFCZ	Omaha Central High School	Omaha, Neb.
KAD	Y. M. C. A.	Denver, Colo.	KFDA	Adler's Music Store	Baker, Oregon
KDKA	Westinghouse Electric & Mfg. Co.	East Pittsburgh, Pa.	KFDB	Mercantile Trust Co. of California	San Francisco, Cal.
KDN	Meyberg Co., Iseo J.	San Francisco, Calif.	KFDD	Radio Supply Co.	Spokane, Wash.
KDPM	Westinghouse Elect. & Mfg. Co.	Cleveland, Ohio.	KFDF	St. Michael's Cathedral	Boise, Idaho
KDPT	Southern Electrical Co.	San Diego, Calif.	KFDH	Wyoming Radio Corp.	Casper, Wyoming
KDYL	Telegram Publishing Co.	Salt Lake City, Utah	KFDI	University of Arizona	Tucson, Ariz.
KDYM	Savoy Theatre	San Diego, Calif.	KFDJ	Oregon Agricultural College	Corvallis, Ore.
KDYN	Great Western Radio Corp	Redwood City, Calif.	KFDL	Knight-Campbell Music Co.	Denver, Colo.
*KDYO	Carlson & Simpson	San Diego, Calif.	KFDO	Cutting, H. Everett	Bozeman, Mont.
KDYO	Oregon Institute of Technology.	Portland, Oreg.	KFDP	Hawkeye Radio & Supply Co.	Des Moines, Iowa
*KDYR	Pasadena Star-News Pub. Co.	Pasadena, Cal.	KFDR	Bullock's Hardware & Sporting Goods	York, Neb.
KDYS	The Tribune, Inc.	Great Falls, Mont.	KFDU	Nebraska Radio Elect. Co.	Lincoln, Neb.
KDYV	Cope & Cornwell Co.	Salt Lake City, Utah	KFDV	Gilbrech & Stinson	Fayetteville, Ark.
KDYW	Smith, Hughes & Co.	Phoenix, Ariz.	KFDY	South Dakota State College	Brookings, S. D.
KDYX	Star-Bulletin Pub. Co.	Honolulu, T. H.	KFDZ	Harry O. Iverson	Minneapolis, Minn.
KDZA	Arizona Daily Star	Tucson, Ariz.	KFEB	The City of Taft	Taft, Calif.
KDZB	Frank E. Siefert	Bakersfield, Calif.	KFEC	Meir & Frank Co.	Portland, Oregon
KDZE	The Rhodes Co.	Seattle, Wash.	*KFED	Billings Polytechnic Institute	Polytechnic, Mont.
KDZF	Automobile Club of So. Calif.	Los Angeles, Calif.	KFEJ	Guy Greson	Tacoma, Wash.
KDZG	Cyrus Peiree & Co.	San Francisco, Calif.	KFEL	Winner Radio Corp.	Denver, Colo.
KDZH	Fresno Evening Herald	Fresno, Calif.	KFEP	Radio Equipment Co.	Denver, Colo.
KDZI	Electric Supply Co.	Wenatchee, Wash.	KFEQ	Scroggin, J. L.	Oak, Neb.
KDZK	Nevada Machinery & Electric Co.	Reno, Nev.	KFER	Auto Electric Service Co., Inc.	Fort Dodge, Iowa
KDZL	Rocky Mountain Radio Corp.	Ogden, Utah	KFEV	Radio Electric Shop	Douglas, Wyoming
KDZM	E. A. Hollingworth	Centraha, Wash.	KFFA	Dr. R. O. Shelton	San Diego, Calif.
*KDZP	Newbery Elect. Corp.	Los Angeles, Cal.	KFFJ	Jenkins Furniture Co.	Boise, Idaho
KDZQ	William D. Pyle	Denver, Colo.	KFFK	Marksheffel Motor Co.	Colorado Springs, Colo.
KDZR	Bellingham Publishing Co.	Bellingham, Wash.	KFFL	Loewenthal Bros.	Lamoni, Iowa
KDZT	Seattle Radio Assn.	Seattle, Wash.	KFFG	Buchanan Stevens & Co.	Pueblo, Colo.
KDZU	Western Radio Corporation	Denver, Colo.	KFFH	Astoria Budget	Mt. Vernon, Wash.
*KDZX	Claude W. Gerbers	San Francisco, Calif.	KFFI	P. L. Boardwell	Astoria, Oregon
KDZW	Glad Tidings Tabernacle	San Francisco, Calif.	KFFJ	Leland Stanford Jr. Univ.	Stanford University, Calif.
KDZZ	Kinney Bros. & Sipprell	Everett, Wash.	KFFK	P. L. Boardwell	Hood River, Ore.
KFAB	Pacific Radiofone Co.	Portland, Oreg.	KFFL	Fallon Company	Santa Barbara, Calif.
*KFAD	Glendale Daily Press	Glendale Calif.	KFFM	Anthony, Earle C., Inc.	Los Angeles, Calif.
KFAE	McArthur Bros. Mercantile Co.	Phoenix, Ariz.	KFFN	Precision Shop, The	Grimley, Calif.
KFAF	State College of Washington.	Pullman, Wash.	KFFO	Foster-Bradbury Radio Store	Yakima, Wash.
KFAJ	Western Radio Corp.	Denver, Colo.	KFFP	Doerr-Mitchell Electrical Co.	Spokane, Wash.
KFAK	University of Colorado	Boulder, Colo.	KFFQ	Mullins, Electric Co., Wm. A.	Tacoma, Wash.
KFAJ	Electric Shop	Moscow, Idaho	KFFR	Electric Lighting & Wiring Co.	Hollywood, Calif.
KFAQ	Standard Publishing Co.]	Butte, Mont.	*KFFS	Pomona Fixture & Wiring Co.	Pomona, Calif.
KFAQ	City of San Jose	San Jose, Calif.	KGG	Hallock & Watson Radio Service	Portland, Ore.
KFAR	Olesen, O. K.	Hollywood, Calif.	KGN	Northwestern Radio Mfg. Co.	Portland, Ore.
KFAS	Reno Motor Supply Co.	Reno, Nev.	KGO	Altadena Radio Laboratory	Altadena, Calif.
KFAU	Donohue, Dr. S. T.	Eugene, Oregon	KGU	Mulrony, Marion A.	Honolulu, Hawaii
KFAV	Independent School District of Boise	Boise City, Idaho	KGV	Portland Oregonian	Portland, Oregon
KFAW	Cooke & Chapman	Venice, Calif.	KGW	St. Martins College (Rev. S. Ruty)	Lacey, Wash.
KFAW	Radio Den, The	Santa Ana, Calif.	KHD	Aldrich Marble & Granite Co.	Colorado Springs, Colo.
KFAY	Virgin Milling Co., W. J.	Central Point, Oreg.	KHJ	Kierulff & Co., C. R.	Los Angeles, Calif.
KFAZ	Weatherell, C. H.	Readley, Calif.	*KHK	Wasmer, Louis	Seattle, Wash.
*KFBA	Ramey & Bryant Radio Co.	Lewiston, Idaho	KJJ	Standard Radio Co.	Los Angeles, Calif.
KFBB	Buttrell & Co., F. A.	Havre, Mont.	KJK	Radio Shop, The	Stuckville, Calif.
KFBC	Azbill, W. K.	San Diego, Calif.	KJL	Gould, C. O.	Sunnyton, Calif.
KFBD	Welsh, Clarence V.	Hanford, Calif.	KJM	Kraft, Vincent I.	Seattle, Wash.
KFBE	Horn, Reuben H.	San Luis Obispo, Calif.	KJN	Bible Institute of Los Angeles	Los Angeles, Calif.
KFBF	Smith, F. H.	Butte, Mont.	KJO	Dunn & Co., J. J.	Pasadena, Calif.
KFBG	First Presbyterian Church	Tacoma, Wash.	KJP	Noggle Electric Works	Monterey, Calif.
*KFBH	Boise Radio Supply Co.	Boise, Idaho	KJQ	Kennedy Co., Colin B.	Los Altos, Calif.
KFBK	Kimball-Upson Co.	Sacramento, Calif.	KJR	Warner Brothers	Oakland, Calif.
KFBL	Leese Bros.	Everett, Wash.	KJS	Tribune Publishing Co.	Oakland, Calif.
*KFBM	Cook & Foster	Astoria, Ore.	KJT	Reynolds Radio Co.	Denver, Colorado
*KFBN	Borch Radio Corp.	Oakland, Cal.	KKV	Lindsay, Weatherell & Co.	Reedley, Calif.
*KFBQ	Savage Elect. Co.	Prescott, Ariz.	KKW	San Joaquin Light & Power Corporation	Fresno, Calif.
KFBT	Gas & Elect. Supply Co.	Trinidad, Colo.	KKX	Roswell Public Service Co.	Roswell, N. Mex.
KFBV	Thomas, Bishop N. S.	Laramie, Wyoming	KKY	Bullock's	Los Angeles, Calif.
*KFC	Clarence O. Ford	Colorado Springs, Colo.	KKL	Love Electric Co.	Tacoma, Wash.
KFCB	Northern Radio & Electric Co.	Seattle, Wash.	KKM	Beacon Light Co.	Los Angeles, Calif.
KFC	Nielsen Radio Supply Co.	Phoenix, Ariz.	KKN	North Coast Products Co.	Aberdeen, Wash.
KFC	Auto Supply Co.	Wallace, Idaho	KKO	Radio Supply Co.	Los Angeles, Calif.
KFC	Salem Elect. Co.	Walla Walla, Oreg.	KKP	Electric Lighting Supply Co.	Los Angeles, Calif.
KFC	Frank A. Moore	Walla Walla, Wash.	KKQ	Young Men's Christian Association	Denver, Colo.
KFC	Electric Service Station	Billings, Mont.	KKR	New Mexico College of Agriculture and Mechanical Arts	State College, N. Mex.
KFC	Colorado Springs Radio Co.	Colorado Springs, Colo.	KKS	Spokane Chronicle	Spokane, Wash.
KFC	Los Angeles Union Stock Yards	Los Angeles, Calif.	KKT	Western Radio Electric Co.	Los Angeles, Calif.
KFC	Richmond Radio Shop	Richmond, Calif.	KKU	Holzwasser Inc.	Dan Diego, Calif.
KFC	Flygare, Ralph W.	Ogden, Utah	KKV	Detroit Police Dept.	Detroit, Michigan
KFC	Motor Service Station	Casper, Wyoming	KKW	Modesto Evening News	Modesto, Calif.
KFC	Mahafey, Jr., Fred	Houston, Texas	KKX	Hale Bros., Inc.	San Francisco, Calif.
KFC	Western Union College	Le Mars, Iowa	KKY	University of California	Berkeley, Calif.



# The Grid

## QUESTIONS AND ANSWERS

The Grid is a Question and Answer Department maintained especially for the radio amateurs. Full answers will be given wherever possible. In answering questions, those of a like nature will be grouped together and answered by one article. Every effort will be made to keep the answers simple and direct, yet fully self-explanatory. Questions should be addressed to Editor, "The Grid," Radio Broadcast, Garden City, N. Y. The letter containing the questions should have the full name and address of the writer and also his station call letter, if he has one. Names, however, will not be published.

### OPERATING LOUD-SPEAKERS AT A DISTANCE

*Please tell me how many loud-speakers (say Magnavoxes) could be worked off a two-stage audio-frequency set—and is there any limitation to the distance they could be placed from the set, as in neighbors' houses (the receiving set being in one house, and the others having the loud-speakers operated from the same set?)*

W. H. M., MIAMI, ARIZONA.

**T**HEORETICALLY, any number of loud-speakers may be operated in series from one set, if the impedance and voltage are corrected and the signal on a single loud-speaker is strong. Practically, it should not be difficult to operate a dozen or so in this manner.

However, there are much more definite limits, imposed principally by capacity effects, on the distance which such loud-speakers may be operated from the receiving apparatus. The leads running to the loud-speaker are virtually a shunt capacity, and the loss in signal strength is comparable to that occasioned by shunting too large a condenser across the telephone receivers. In some cases the capacity may cause distortion, though in the majority of loud-speakers, this would be counteracted by the inductance in the loud-speaker windings. The undesirable effects of capacity may be somewhat reduced by employing a single wire with a ground return.

If Magnavoxes are used, it is suggested that a separate six-volt battery be located in the immediate vicinity of each Magnavox to excite its field.

For use in neighboring houses, assuming the total length of wire to be less than eight hundred feet, the problem is not a difficult one. In consideration of both economy and simplicity, we suggest using loud-speakers having permanent fields, such as the Western Electric (without power amplifier.) They should be connected in series, Figure 1, using well insulated wire of size number twenty-four or larger, with a final return through the ground. As the wire carries a comparatively high voltage, it should be carefully insulated wherever braced or supported. Forty to a hundred additional volts should be used on the final step of amplification.

For farther distances, or a greater multiplicity of loud talkers, it would be best to distribute the signals from the first step of the receiver, and equip each loud-talker with a

separate one-step amplifier using individual A and B batteries. The auxiliary apparatus would, of course, be housed under the same roof as the loud-speaker itself. (Care should be taken in running the lines for such an installation, that the wires are not closely parallel to lighting or power leads, for all induced disturbances will be amplified.) With this arrangement, Magnavoxes may be conveniently used, the externally excited fields being supplied from the amplifier A batteries.

By elaborating on this latter system, it should be practical to equip the houses of an entire village with loud-talkers operated from a single well located receiver. However, before undertaking such a venture, it would be well to consult a telephone expert, and finally to do the actual installing under his supervision.

### TUNED CIRCUITS

*What relation has the wavelength to which the plate variometer is tuned, to the intercepted wavelength?*

*Can regeneration be controlled in the ultra-audion circuit?*

*What would be the advantage of using both a tickler and tuned plate circuit simultaneously?*

L. U., BELLEFONTAINE, OHIO.

**T**HE wavelength of the plate circuit in a variometer regenerative set is tuned by means of the plate variometer to within a few meters of the wave of the received signal. The degree of regeneration increases as the resonance point is approached, until, just before the plate circuit is perfectly tuned, the bulb oscillates, a condi-

*(Continued on page 86)*

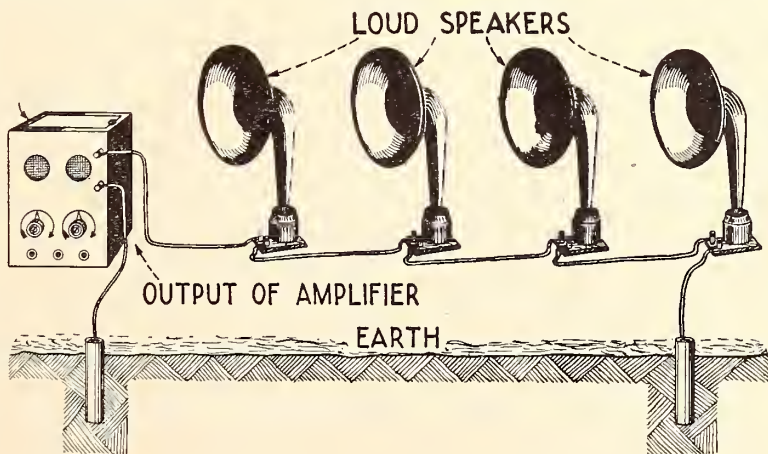

KQL	Kluge, Arno A.	Los Angeles, Calif.	WCAS	William Hood Dunwoody Industrial Institute	Minneapolis, Minn.
KQP	Appie City Radio Club	Hood River, Ore.	WCAT	S. Dakota State School of Mines	Rapid City, S. Dak.
KQT	Electric Power & Appliance Co.	Yakima, Wash.	WCAU	Philadelphia Radiophone Co.	Philadelphia, Pa.
KQV	Doubleday-Hill Electrical Co.	Pittsburgh, Pa.	WCAV	J. C. Dice Electric Co.	Little Rock, Ark.
KQW	Herrold, Charles D.	San Jose, Calif.	WCAX	University of Vermont	Burlington, Vt.
KQY	Stubbs Electric Co.	Portland, Ore.	WCAY	Kesselmen O'Dresscoll Co.	Milwaukee, Wis.
KRE	Maxwell Electric Co.	Berkeley, Calif.	*WCAZ	Compton, Robert	Carthage, Ill.
KSC	Hael & Co.	San Jose, Calif.	WCE	Findley Electric Co.	Minneapolis, Minn.
KSD	Post Dispatch	St. Louis, Mo.	*WCJ	Gilbert Co., A. C.	New Haven, Conn.
KSL	Emporium, The	San Francisco, Calif.	WCK	Stix-Baer-Fuller	St. Louis, Mo.
KSS	Prest & Dean Radio Research Laboratory	Long Beach, Calif.	WCM	University of Texas	Austin, Texas
KTW	First Presbyterian Church	Seattle, Wash.	WCN	Clark University	Worcester, Mass.
KUO	The Examiner Printing Co.	San Francisco, Calif.	WCX	Detroit Free Press	Detroit, Mich.
KUS	City Dye Works & Laundry Co.	Los Angeles, Calif.	WDC	Illinois Watch Co.	Springfield, Ill.
KUY	Coast Radio Company	El Monte, Calif.	WDAD	Central Kansas Radio Supply	Lindsberg, Kan.
*KVQ	Hobrecht, J. C.	Sacramento, Calif.	WDAE	Tampa Daily Times	Tampa, Fla.
KWG	Portable Wireless Telephone Co.	Stockton, Calif.	WDAF	Kansas City Star	Kansas City, Mo.
KWH	Los Angeles Examiner	Los Angeles, Calif.	WDAH	Mine & Smelter Supply Co.	El Paso, Tex.
KXD	Herald Publishing Co.	Modesto, Calif.	WDAI	Hughes Electrical Corp.	Syracuse, N. Y.
KXS	Braun Corporation	Los Angeles, Calif.	WDAJ	Atlanta & West Point R. R. Co.,	College Park, Ga.
*KGF	Thearle Music Co.	San Diego, Calif.	WDAK	The Courant	Hartford, Conn.
KGY	Hawley, Willard P., Jr.	Portland, Ore.	WDAL	Florida Times Union	Jacksonville, Fla.
KYI	Alfred Harrell	Bakersfield, Calif.	WDAM	Weston Electric Co.	New York, N. Y.
KYJ	Meyberg Co., Leo J.	Los Angeles, Calif.	*WDAN	Glenwood Radio Corp.	Shreveport, La.
KYO	Electric Shop	Honolulu, Hawaii	WDAO	Automotive Electric Co.	Dallas, Texas
KYW	Westinghouse Electric & Mfg. Co.	Chicago, Ill.	WDAP	Drake Hotel	Chicago, Ill.
*KYY	Radio Telephone Shop, The	San Francisco, Calif.	*WDAQ	Hartman-Riker Electric Machine Co.	Brownsville, Pa.
KZC	Public Market & Department Stores	Co. Seattle, Wash.	WDAE	Lit Bros.	Philadelphia, Pa.
KZI	Cooper, Irving S.	Los Angeles, Calif.	WDAS	Samuel W. Waite	Worcester, Mass.
KZM	Allen, Preston, D.	Oakland, Calif.	WDAU	Slocum & Kilburn	New Bedford, Mass.
KZN	Deseret News	Salt Lake City, Utah	*WDAV	Muskogee Daily Phoenix	Muskogee, Okla.
KZV	Wenatchee Battery & Motor Co.	Wenatchee, Wash.	WDAX	First National Bank	Centerville, Iowa
*KZY	Atlantic-Pacific Radio Supplies Co.	Oakland, Calif.	WDAY	Kenneth M. Hance	Fargo, N. D.
KUO	Examiner Printing Co.	San Francisco, Calif.	WDM	Church of the Covenant	Washington, D. C.
NAA	U. S. Government	Arlington, Md.	WDT	Ship Owners Radio Service	New York, N. Y.
NOF	U. S. Navy	Anacostia, Md.	*WDV	Yeiser, John O., Jr.	Omaha, Nebraska
WAAB	Jensen, Valdemar	New Orleans, La.	WDW	Radio Construction & Electric Co.	Washington, D. C.
WAAC	Tulane University of Louisiana	New Orleans, La.	*WDY	Radio Corp. of America	Roselle, Park, N. J.
WAAD	Ohio Mechanics Institute	Cincinnati, Ohio	WDZ	Bush, James L.	Tuscola, Ill.
WAAE	St. Louis Chamber of Commerce	St. Louis, Mo.	WEAA	Fallain & Lathrop	Flint, Mich.
WAAF	Union Stock Yards & Transit Co.	Chicago, Illinois	WEAB	Standard Radio Equipment Co.	Fort Dodge, Ia.
*WAAG	Elliott Electric Co.	Shreveport, La.	WEAC	Baines Electric Service Co.	Terre Haute, Ind.
WAAH	Commonwealth Electric Co.	St. Paul, Minn.	WEAD	Northwest Kansas Radio Sup. Co.	Atwood, Kans.
WAAJ	Eastern Radio Institute	Boston, Mass.	WEAE	Virginia Polytechnic Institute	Blacksburg, Va.
WAAK	Gimbel Brothers	Milwaukee, Wis.	WEAF	American Tel. & Tel. Co.	New York, N. Y.
WAAI	Minnesota Tribune Co.	Minneapolis, Minn.	WEAG	Nichols-Hineline-Bassett	Edgewood, R. I.
WAAM	Nelson Co., I. R.	Newark, N. J.	WEAH	Wichita Board of Trade & Landers Radio Co.	Wichita, Kans.
WAAN	University of Missouri	Columbia, Mo.	WEAI	Cornell University	Ithaca, N. Y.
*WAAO	Radio Service Co.	Charleston, W. Va.	WEAJ	University of South Dakota	Vermillion, S. D.
WAAW	Taylor, Otto W.	Wichita, Kansas	WEAK	Julius B. Abercrombie	St. Joseph, Mo.
*WAAZ	New England Motor Sales Co.	Greenwich, Conn.	WEAM	Borough of North Plainfield	North Plainfield, N. J.
*WAAE	Groves-Thornon Hardware Co.	Huntington, W. Va.	WEAN	Shepard Co.	Providence, R. I.
WAAV	Georgia Radio Co.	Decatur, Ga.	WEAO	Ohio State University	Columbus, Ohio
*WAAW	Athens Radio Co.	Athens, O.	WEAP	Mobile Radio Co.	Mobile, Ala.
WAAZ	Omaha Grain Exchange	Omaha, Neb.	WEAQ	Young Men's Christian Association	Berlin, N. H.
WAAZ	Yahrling-Raynor Piano Co.	Youngstown, O.	WEAR	Baltimore American & News Pub. Co.	Baltimore, Md.
WAH	Hollister-Miller Motor Co.	Emporia, Kansas	WEAS	Hecht Co.	Washington, D. C.
*WAAZ	Midland Refining Co.	El Dorado, Kansas	WEAT	John J. Fogarty	Tampa, Fla.
WAAZ	Radio Service Corp.	Crofton, Pa.	WEAU	Davidson Bros. Co.	Sioux City, Iowa
WAWJ	Indian Pipe Wire Corp.	Princeton, Ind.	WEAV	Sheridan Electric Service Co.	Rushville, Neb.
WBA	Marshall-Gerkin Co.	Toledo, Ohio	WEAW	Arrow Radio Lab.	Anderson, Ind.
WBA	Purdue University	West Lafayette, Ind.	WEAX	T. J. M. Daly	Little Rock, Ark.
*WBA	Potter, Andrew J.	Syracuse, N. Y.	WEAZ	Will Horwitz, Jr.	Houston, Tex.
WBAD	Sterling Electric Co. & Journal Printing Co.	Minneapolis, Minn.	WEB	Donald Redmond	Waterloo, Iowa
WBAE	Bradley Polytechnic Institute	Peoria, Ill.	WEH	Benwood Co.	St. Louis, Mo.
WBAF	Middleton, Fred M.	Morestown, N. J.	WEI	Midland Refining Co.	Tulsa, Okla.
WBAG	Diamond State Fibre Co.	Bridgeport, Pa.	WEV	Hurlburt-Still Electrical Co.	Houston, Tex.
WBAH	Dayton Co.	Minneapolis, Minn.	WEW	St. Louis University	St. Louis, Mo.
WBAJ	Marshall, Gerkin Co.	Toledo, O.	WFAA	A. H. Belo & Co.	Dallas, Tex.
WBAM	Rennysen, T. B.	New Orleans, La.	WFAE	Carl F. Woese	Syracuse, N. Y.
WBAN	Wireless Phone Corporation	Paterson, N. J.	WFAF	Superior Radio Co.	Superior, Wis.
WBAO	Millikin University	Decatur, Ill.	WFAH	Watson Weldon Motor Supply Co.	Salina, Kan.
WBAP	The Star Telegram	Fort Worth, Texas	WFAI	H. C. Spratley Co.	Poughkeepsie, N. Y.
WBAW	Republican Publishing Co.	Hamilton, Ohio	WFAJ	Radio Engineering Laboratory	Waterford, N. Y.
WBAV	Erner & Hopkins Co.	Columbus, Ohio	WFAK	Electric Supply Co.	Port Arthur, Tex.
WBAW	Marietta College	Marietta, Ohio	WFAI	Hi-Grade Wireless Instrument Co.	Asheville, N. C.
WBAZ	John H. Stenger, Jr.	Wilkes-Barre, Pa.	WFAJ	Domestic Electric Co.	Brentwood, Mo.
WBAZ	Amer. Tel. & Tel. Co.	New York, N. Y.	WFAK	Houston Chronicle Publishing Co.	Houston, Tex.
WBL	T. & H. Radio Co.	Anthony, Kansas	WFAI	Times Publishing Co.	St. Cloud, Minn.
WBS	May (Inc.) D. W.	*Newark, N. J.	WFAI	Hutchinson Electric Service Co.	Hutchinson, Minn.
WBT	Southern Radio Corporation	Charlottesville, N. C.	WFAI	Brown's Business College	Peoria, Ill.
WBU	City of Chicago	Chicago, Ill.	WFAI	Missouri Wesleyan College & Cameron Radio Co.	Cameron, Mo.
WBZ	Westinghouse Electric & Mfg. Co.	Springfield, Mass.	*WFAI	Hall & Stubbs	Stanford, Me.
WCAB	Newburgh News Printing & Pub. Co.	Newburgh, N. Y.	WFAI	United Radio Corporation	Fort Wayne, Ind.
WCAC	John Fink Jewelry Co.	Fort Smith, Ark.	WFAI	Daily Argus Leader	Sioux Falls, S. Dak.
WCAD	St. Lawrence University	Canton, Ohio	WFAI	Lewis, Edwin C., Inc.	Boston, Mass.
WCAG	Kaufmann & Baer Co.	Pittsburg, Pa.	WFAI	University of Nebraska	Lincoln, Neb.
WCAG	Michigan Limehouse & Chemical Co.	Rodgers, Mich.	WFAI	Miami Daily Metropolis	Miami, Fla.
WCAG	Daily States Publishing Co.	New Orleans, La.	WFAI	Kent, Arthur L.	Binghamton, N. Y.
WCAH	Entreklin Electric Co.	Columbus, O.	WFAI	Daniels Radio Supply Co.	Independence, Kan.
WCAJ	Nebraska Wesleyan University	University Place, Neb.	WFAI	South Carolina Radio Shop	Charleston, S. C.
WCAK	Alfred P. Daniel	Houston, Tex.	WFAI	Strawbridge & Clothier	Philadelphia, Pa.
WCAL	St. Olaf College	Northfield, Minn.	WFAI	Rike-Kumler Co.	Dayton, Ohio
WCAM	Villanova College	Villanova, Pa.	*WFO	Cosradio Co.	Wichita, Kansas
WCAN	Southeastern Radio Telephone Co.	Jacksonville, Fla.	WFO	ORV Radio Co.	Houston, Tex.
WCAD	Sanders & Stayman Co.	Baltimore, Md.	WFO	Orpheum Radio Stores Co.	Brooklyn, N. Y.
WCAD	Central Radio Service	Decatur, Ill.	WGAB	Spanish-American School of Radio Telegraphy	Ensenada, Porto Rico
WCAP	Tri-State Radio Mfg. & Supply Co.	Defiance, Ohio	WGAC		
*WCAR	Alamo Radio Electric Co.	San Antonio, Tex.	WGAD		





## One of these panels fits *your* set

**Y**ESTERDAY you would have had to wait while the size was cut from sheet stock. Today you can get the panel you need immediately. Celoron Radio Panels come in standard sizes, one of which will be right for any set you may build.

Each Celoron Panel is already cut and wrapped ready for you to take home. Full instructions for working and finishing are on the glassine paper around every panel.

The sizes have been selected only after careful study of present-day needs. Your dealer should be able to supply you with any of the following sizes:

- |                           |                             |
|---------------------------|-----------------------------|
| 1.—6 x 7 x $\frac{1}{8}$  | 4.—7 x 18 x $\frac{3}{16}$  |
| 2.—7 x 9 x $\frac{1}{8}$  | 5.—9 x 14 x $\frac{3}{16}$  |
| 3.—7 x 12 x $\frac{1}{8}$ | 6.—7 x 21 x $\frac{3}{16}$  |
|                           | 7.—12 x 14 x $\frac{3}{16}$ |

*Also comes in sheets and can be cut in special sizes when desired.*

Condensite Celoron, the material used for these panels, has high insulating qualities, high dielectric strength, and low dielectric losses. It is used by many of the leading manufacturers of radio equipment. It is easily machined and can be sawed, drilled, turned, or milled.

### Send for free booklet

We have prepared an attractive booklet, "Tuning in on a New World," which tells more about Celoron and gives lists of leading broadcasting stations in the United States and Canada, symbols used in reading radio diagrams, and several highly efficient radio hook-ups. This instructive booklet will be of use to every radio fan and will be sent to you free of charge upon request. Write today.

## Diamond State Fibre Company

BRIDGEPORT

(near Philadelphia)

PENNSYLVANIA

Offices in Principal Cities

In Canada: Diamond State Fibre Co., of Canada Limited, 245 Carlaw Ave., Toronto

**To radio dealers:** Celoron Radio Panels cut in standard sizes offer an exceptional opportunity for quick sales and substantial profit. Write for special dealer price list showing standard assortments.



CONDENSITE  
**CELORON**  
STANDARD RADIO PANEL

WGAF	Goller Radio Service	Tulsa, Okla.	WJAJ	Y. M. C. A.	Dayton, O.
WGAH	New Haven Elect. Co.	New Haven, Conn.	WJAK	White Radio Laboratory	Stockdale, O.
WGAI	Southern Equipment Co.	San Antonio, Tex.	*WJAL	Victor Radio Corp.	Portland, Me.
WGAL	Gass, W. H.	Shenandoah, Iowa	WJAM	D. M. Perham	Cedar Rapids, Iowa
WGAK	Macon Electric Co.	Macon, Ga.	WJAN	Peoria Star & Peoria Radio Sales Co.	Peoria, Ill.
WGAL	Lancaster Electric Supply & Const. Co.	Lancaster, Pa.	WJAP	Kelly Duluth Co.	Duluth, Minn.
WGAM	Orangeburg Radio Equipment Co.	Orangeburg, S. C.	WJAR	Outlet Co., The	Providence, R. I.
WGAN	Lloyd, Cecil E.	Pensacola, Fla.	WSAS	Capper Publications	Topeka, Kans.
WGAQ	Patterson, W. G.	Shreveport, La.	WJAT	Kelley-Vawter Jewelry Co.	Marshall, Mo.
WGAR	South American	Fort Smith, Ark.	*WJAV	Yankton College	Yankton, S. D.
*WGAS	Ray—Di—Co. Organization	Chicago, Illinois	WJAX	Union Trust Co.	Cleveland, O.
WGAT	American Legion, Dept. of Nebraska	Lincoln, Neb.	WJAZ	Chicago Radio Lab.	Chicago, Ill.
WGAU	Limb, Marcus G.	Wooster, Ohio	WJD	Howe, Richard H.	Granville, Ohio
WGAU	B. H. Radio Co.	Savannah, Ga.	WJH	White & Boyer Co.	Washington, D. C.
WGAU	Albright, Ernest Co.	Philadelphia, Pa.	*WJK	Service Radio Equipment Co.	Toledo, Ohio
WGAU	Radio Elect. Co.	Washington, O.	WJT	Electric Equipment Co.	Erie, Pa.
WGAU	North Western Radio Co., Inc.	Madison, Wis.	WJX	DeForest Radio Telephone & Telegraph Co.	New York, N. Y.
WGAZ	South Bend Tribune	South Bend, Ind.			
WGF	Register & Tribune, The	Des Moines, Iowa			
WGH	Montgomery Light & Power Co.	Montgomery, Ala.			
WGI	American Radio & Research Corporation	Medford Hillside, Mass.			
WGL	Howlett, Thomas, F. J.	Philadelphia, Pa.	WJZ	Westinghouse Electric & Mfg. Co.	Newark, N. J.
WGM	Atlanta Constitution	Atlanta, Ga.	WKAA	Landans Music & Jewelry Co.	Wilkes-Barre, Pa.
WGR	Federal Telephone & Telegraph Co.	Buffalo, N. Y.	WKAC	Star, H. F. & Republican Times	Cedar Rapids, Iowa
WGU	Fair, The	Chicago, Ill.	*WKAD	Paar Publishing Co.	Lincoln, Neb.
WGV	Interstate Electric Co.	New Orleans, La.	WKAF	Looff, Charles	East Providence, R. I.
WGY	General Electric Co.	Schenectady, N. Y.	WKAG	W. S. Radio Supply Co.	Wichita Falls, Texas
WHAA	State University of Iowa	Iowa City, Iowa	*WKAH	Bruce, M. D., Edwin T.	Louisville, Ky.
WHAB	Thomson, Clark W.	Galveston, Texas	WKAI	Planet Radio Co.	West Palm Beach, Fla.
WHAC	Cole Bros., Electric Co.	Waterloo, Iowa	WKAJ	Fargo Plumbing & Heating Co.	Fargo, N. D.
WHAD	Marquette University	Milwaukee, Wis.	WKAK	Okfuskee County News	Okemah, Okla.
*WHAE	Automotive Electric Serv. Co.	Sioux City, Iowa	WKAL	Gray & Gray	Orange, Tex.
WHAF	Radio Electric Co.	Pittsburgh, Pa.	*WKAM	Hastings Daily Tribune	Hastings, Neb.
WHAG	University of Cincinnati	Cincinnati, O.	WKAN	Alabama Radio Mfg. Co.	Montgomery, Ala.
WHAH	Griffin, John T.	Joplin, Mo.	WKAP	Flint, Dutee Wilcox	Cranston, R. I.
WHAI	Radio Equipment & Mfg. Co.	Davenport, Iowa	WKAQ	Radio Corp. of Porto Rico	San Juan, P. R.
WHAJ	Bluefield Daily Telegraph	Bluefield, W. Va.	WKAJ	Michigan Agri. College	East Lansing, Mich.
WHAK	Roberts Hardware Co.	Clarksburg, W. Va.	WKAS	Lines Music Co., L. E.	Springfield, Mo.
WHAL	Phillips, Jeffery & Derby	Lansing, Mich.	WKAT	Frankfort Morning Times	Frankfort, Ind.
WHAM	University of Rochester	Rochester, N. Y.	WKAU	Laconia Radio Club	Laconia, N. H.
WHAN	Southwestern Radio Co.	Wichita, Kan.	WKAU	Turner Cycle Co.	Beloit, Wis.
WHAP	Hill, F. A.	Savannah, Ga.	WKAX	Macfarlane, William A.	Bridgeport, Conn.
WHAP	Otta, Dewey L.	Decatur, Ill.	*WKAY	Brenau College	Gainesville, Ga.
WHAP	Semmes Motor Co.	Washington, D. C.	WKAZ	Landau's Music & Jewelry Co.	Wilkes-Barre, Pa.
WHAR	Paramount Radio & Electric Co.	Atlantic City, N. J.	WKC	Zamoiski Co., Joseph M.	Baltimore, Md.
WHAS	Courier Journal & Louisville Times	Louisville, Ky.	WKN	Richman-Crosby Co.	Memphis, Tenn.
WHAT	Yale Democrat & Yale Telephone Co.	Yale, Okla.	WKO	Oklahoma Radio Shop	Oklahoma City, Okla.
WHAU	Corinth Radio Supply Co.	Corinth, Miss.	WKL	Grossman, George F.	Carrollton, Mo.
WHAU	Wilmington Electrical Specialty Co.	Wilmington, Del.	WLAB	North Carolina State College	Raleigh, N. C.
WHAU	Pierce Elect. Co.	Tampa, Fla.	*WLAD	Arvanette Radio Supply Co.	Hastings, Neb.
WHAU	Holyoke Street Ry. Co.	Holyoke, Mass.	WLAF	Johnson Radio Co.	Lincoln, Neb.
WHAU	Huntington Press	Huntington, Ind.	WLAG	Cutting & Washington Radio Corp.	Minneapolis, Minn.
WHAZ	Rensselaer Polytechnic Institute	Troy, N. Y.	WLAH	Woodworth, Samuel	Syracuse, N. Y.
WHA	University of Wisconsin	Madison, Wis.	WLAJ	Waco Electric Supply Co.	Waco, Texas
WHB	Sweeney School Co.	Kansas City, Mo.	WLAJ	Vermont Farm Machine Co.	Bellows Falls, Vt.
WHD	West Virginia University	Morgantown, W. Va.	WLAJ	Morrow Radio Co.	Tulsa, Okla.
WHK	Cox, Warren R.	Cleveland, O.	WLAN	Putnam Hardware Co.	Houlton, Me.
WHN	Ridgewood Times Printing & Publishing Co.	Ridgewood, N. Y.	WLAO	Anthracite Radio Shop	Scranton, Pa.
WHO	Rochester Times Union	Rochester, N. Y.	WLAO	Jordan, W. V.	Louisville, Ky.
WHU	Duck Co., William B.	Toledo, Ohio	*WLAP	Shilling, A. E.	Kalamazoo, Mich.
*WHW	Seeley, Stuart, W.	East Lansing, Mich.	WLAQ	Mickel, A. E. Co.	Marshalltown, Iowa
WHX	Iowa Radio Corporation	Des Moines, Iowa	WLAS	Hutchinson Grain Radio Co.	Hutchinson, Iowa
*WIAA	Waupaca Civic & Commerce Assn.	Wauopaca, Wis.	WLAT	Bosch Co., Chas. G.	Burlington, Kans.
WIAB	Joslyn Automobile Co.	Rockford, Ill.	WLAV	Electric Shoo Inc.	Pensacola, Fla.
WIAC	Galveston Tribune	Galveston, Texas	WLAW	New York Police Dept.	New York, N. Y.
WIAD	Ocean City Yacht Club	Ocean City, N. J.	WLAX	Greencastle Community Broadcasting Station	Greencastle, Ind.
WIAE	Zimmerman, Mrs. Robert E.	Venton, Iowa	WLAY	Northern Commercial Co. of Alaska	Fairbanks, Alaska
WIAF	De Cortin, Gustav A.	New Orleans, La.	WLAZ	Hutton & Jones Elect. Co.	Warren, O.
WIAG	Mathews Elect. Supply Co.	Birmingham, Ala.	WLB	University of Minnesota	Minneapolis, Minn.
WIAH	Continental Radio Mfg. Co.	Newton, Iowa	WLDO	Anthracite Radio Shop	Scranton, Pa.
WIAI	Heers Stores Co.	Springfield, Mo.	WLK	Hamilton Manufacturing Co.	Indianapolis, Ind.
WIAJ	Fox River Valley Radio Supply Co.	Neenah, Wis.	WLW	Crosley Manufacturing Co.	Cincinnati, O.
WIAK	Journal Stockman, The	Omaha, Neb.	WMA	Arrow Radio Laboratories	Anderson, Ind.
WIAL	Standard Radio Service Co.	Norwood, Ohio	WMA	Radio Supply Co.	Oklahoma City, Okla.
WIAN	Chronicle & News Pub. Co.	Allentown, Pa.	WMA	Page, F. Edward	Cazenovia, N. Y.
WIAO	School of Engineering of Milwaukee & Wisconsin News	Milwaukee, Wis.	WMA	Atchinson County Mail	Rockport, Mo.
WIAP	Radio Development Corp.	Springfield, Mass.	WMA	Round Hills Radio Corp.	Dartmouth, Mass.
WIAQ	Chronicle Publishing Co.	Marion, Ind.	WMA	The Tucker Electric Co.	Liberal, Kansas
WIAR	Rudy & Sons, J. A.	Paducah, Ky.	WMA	General Supply Co.	Lincoln, Neb.
WIAS	Burlington Hawk Eye—Home Electric Co.	Burlington, Iowa	WMA	Drovers Telegram Co.	Kansas City, Mo.
WIAT	Noel, Leon T.	Tarkio, Mo.	WMA	Norton Laboratories	Lockport, N. Y.
WIAU	American Trust & Savings Bank	Le Mars, Iowa	WMA	Trenton Hardware Co.	Trenton, N. J.
WIAV	New York Radio Laboratories	Binghamton, N. Y.	WMA	Beaumont Radio Equipment Co.	Beaumont, Tex.
WIAW	Saginaw Radio & Elect. Co.	Saginaw, Mich.	WMA	Broad Street Baptist Church	Columbus, O.
*WIAX	Capital Radio Co.	Lincoln, Neb.	WMA	Utility Battery Service	Easton, Pa.
WIAZ	Woodward & Lothrop	Washington, D. C.	WMA	The Fair Corp. & The Chicago Daily News	Chicago, Ill.
WIB	Electric Supply Sales Co.	Miami, Fla.	WMA	Waterloo Electrical Supply Co.	Waterloo, Iowa
WIK	K. & L. Electric Co.	McKeesport, Pa.	WMA	Paramount Radio Corp.	Duluth, Minn.
WIL	Continental Electric Supply Co.	Washington, D. C.	WMA	Louisiana State Fair Ass'n	Shreveport, La.
WIP	Gimbel Brothers	Philadelphia, Pa.	WMA	Alabama Polytechnic Inst.	Auburn, Alabama
WIZ	Cino Radio Mfg. Co.	Cincinnati, O.	WMA	Whapeton Electric Co.	Whapeton, N. D.
WJAB	American Radio Co.	Lincoln, Neb.	WMA	K. & K. Radio Supply Co.	Ann Arbor, Mich.
*WJAC	Redell Co., The	Joplin, Mo.	WMA	Kings Highway Presb. Church	St. Louis, Mo.
WJAD	Jackson's Radio Eng. Lab.	Waco, Texas	WMA	Mercer University	Macon, Ga.
*WJAE	Texas Radio Syndicate	San Antonio, Texas	WMA	Auburn Electrical Co.	Auburn, Me.
WJAG	Huse Publishing Co.	Norfolk, Neb.	WMA	Columbia Radio Co.	Youngstown, O.
*WJAH	Central Park Amusement Co.	Rockford, Ill.	WMA	Commercial Publishing Co.	Memphis, Tenn.
			WMA	Precision Equipment Co.	Cincinnati, Ohio
			WMA	Doubleday-Hill Electrical Co.	Washington, D. C.
			WMA	Park City Daily News	Washington, D. C.
			WMA	Shepard Stores	Boston, Mass.
			WMA	Oklahoma Radio Eng. Co.	Norman, Okla.



## Why do you do it?



## Is your battery always fully charged and fit?

Is it always toned up for best results, whenever friends happen in—throughout every concert?

Keep it at full strength and prolong its life—the simple, easy, inexpensive Tungar way.

Tungar—the go-between from house-lighting circuit to storage battery—attaches wherever there is a lamp or convenience outlet.

You don't have to move the battery. Just connect Tungar, and leave it—any time, day or night.

Tungar is *certain, clean, quiet*. No moving parts to get out of order or make noise.

Good for the auto battery too—the same Tungar.

See one at any good electrical store, or write for literature. Address Section RB5.

Merchandise Department  
General Electric Company  
Bridgeport, Connecticut

*Tungar Battery Charger. Operates on Alternating Current.*

2 Ampere Outfits—\$18.00

5 Ampere Outfits—\$28.00

(Prices east of the Rockies)

Special attachment for

charging 12 or 24 cell

"B" Storage Battery—\$3.00

—fits either size Tungar.

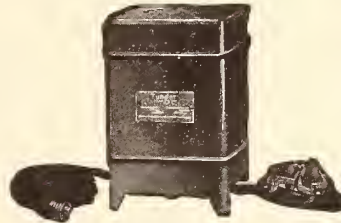

Charge 'em at Home, with

# Tungar

BATTERY CHARGER

A GENERAL ELECTRIC PRODUCT

35A-96C

★ Tested and approved by RADIO BROADCAST ★

*WNAF	Enid Radio Distributing Co.	Enid, Okla.	WQAO	West Texas Radio Co.	Abilene, Texas
*WNAG	Rathert Radio & Elect. Co.	Cresco, Iowa	WQAR	Press Publishing Co.	Muncie, Ind.
*WNAH	Wilkes-Barre Radio Repair Shop	Wilkes-Barre, Pa.	WQAS	Prince-Walter Co.	Lowell, Mass.
*WNAJ	Benson Co.	Chicago, Ill.	WQAT	Radio Equipment Corp.	Westhampton, Va.
WNAL	Rockwell, R. J.	Omaha, Neb.	WQAV	Huntington & Guerry, Inc.	Greenville, S. C.
WNAM	Ideal Apparatus Co.	Evansville, Ind.	WQAW	Catholic University of America	Washington, D. C.
WNAN	Syracuse Radio Tel. Co.	Syracuse, N. Y.	WQAX	S—W Radio Co., J. R. Shumate, Jr.	Thomasville, Ga.
WNAP	Wittenberg College	Springfield, O.	WQAY	Gaston Music & Furniture Co.	Hastings, Neb.
WNAQ	Charleston Radio Electric Co.	Charleston, S. C.	WQX	Walter A. Kushe	Chicago, Ill.
WNAR	C. C. Rhodes	Butler, Mo.	WRAA	Rice Institute	Houston, Tex.
WNAS	Texas Radio Corp.	Austin, Texas	WRAB	Savannah Board of Public Education	Savannah, Ga.
WNAT	Lenning Bros. Co.	Philadelphia, Pa.	WRAC	State Normal School	Mayville, N. D.
WNAV	People's Telep. & Teleg. Co.	Knoxville, Tenn.	WRAD	Taylor Radio Shop	Marion, Kan.
WNAW	Peninsular Radio Club	Fort Monroe, Va.	WRAH	Stanley N. Read	Providence, R. I.
WNAX	Dakota Radio Apparatus Co.	Yankton, S. Dak.	WRAJ	Pickering Co., M. H.	Pittsburgh, Pa.
WNAY	Ship Owners Radio Service	Baltimore, Md.	WRAM	Lombard College	Galesburg, Ill.
WNZ	Shotton Radio Manufacturing Co.	Albany, N. Y.	WRAN	Black Hawk Electric Company	Waterloo, Iowa
WNO	Wireless Telephone Co. of Hudson	Jersey City, N. J.	WRAO	Radio Service Co.	St. Louis, Mo.
WOAA	Hardy, Dr. Walter	Ardmore, Okla.	WRAR	Jacob C. Thomas	David City, Neb.
WOAB	Valley Radio	Grand Forks, N. D.	WRAU	Amarillo Daily News	Amarillo, Tex.
WOAC	Maus Radio Co.	Lima, O.	WRAY	Antioch College	Yellow Springs, O.
WOAD	Whitall Elect. Co.	Waterbury, Conn.	WRK	Dorian Sales Corp.	Scranton, Pa.
WOAE	Medland College	Fremont, Neb.	WRL	Doran Brothers Electrical Co.	Hamilton, O.
WOAF	Tyler Commercial College	Tyler, Tex.	WRM	Union College	Schenectady, N. Y.
WOAG	Apollo Theatre	Belvedere, Ill.	WRP	University of Illinois	Urbana, Illinois
WOAH	Palmetto Radio Corp.	Charleston, S. C.	WRR	Federal Institute of Radio Telegraphy	Camden, N. J.
WOAI	Southern Equipment Co.	San Antonio, Texas	WRW	City of Dallas	Dallas, Tex.
WOAJ	Erwins Electrical Co.	Parsons, Kans.		Sprague Radio Research Laboratory	Tarrytown, N. Y.
WOAK	Collins Hardware Co.	Frankfort, Ky.	WSAA	Sprague, B. S. Elect. Co.	Marietta, O.
WOAL	William E. Woods	Webster Grove, Mo.	WSAB	Southeast Missouri State Teachers' College	Cape Girardeau, Mo.
WOAM	Arthur F. Breisch (temporary-1 day)	Bethlehem, Pa.	WSAC	Clemson Agricultural College	Clemson College, S. C.
WOAN	Vaughn Conservatory of Music	Lawrenceburg, Tenn.	WSAH	Leonard A. G., Jr.	Chicago, Ill.
WOAO	Lyradion Mfg. Co.	Mishawaka, Ind.	WSAJ	Grove City College	Grove City, Pa.
WOAP	Kalamazoo College	Kalamazoo, Mich.	WSAL	Franklin Elect. Co.	Brookville, Ind.
WOAQ	Portsmouth Radio Ass'n	Portsmouth, Va.	WSAS	State of Nebraska	Lincoln, Neb.
WOAR	Henry P. Lundskow	Kenosha, Wis.	WSAT	The Plainview Electric Co.	Plainview, Texas
WOAS	Bailey's Radio Shop	Middletown, Conn.	WSB	Radio Construction Co.	Houston, Texas
WOAT	Boyd Martell Hamp	Wilmington, Del.	WSL	Atlanta Journal	Atlanta, Ga.
WOAU	Sowder Bolling Piano Company	Evansville, Ind.	*WSN	J. & M. Electric Co.	Utica, N. Y.
WOAW	Penn. National Guard	Eric, Pa.	WSV	Ship Owners Radio Service	Norfolk, Va.
WOAX	Woodmen of the World	Omaha, Neb.	WSW	Hunter, L. M. & G. L. Carrington	Little Rock, Ark.
WOAY	Franklyn J. Wolff	Trenton, N. J.	*WSX	Erie Radio Co.	Eric, Pa.
WOAZ	John M. Wilder	Birmingham, Ala.	WSY	Alabama Power Co.	Birmingham, Ala.
WOC	Penick Hughes Co.	Stanford, Texas	WSZ	Marshall-Gerkin Co.	Toledo, O.
*WOE	Palmer School of Chiropractic	Davenport, Iowa	WTAC	Penn. Traffic Co.	Johnstown, Pa.
*WOH	Buckeye Radio Service Co.	Akron, Ohio	WTAS	Carpenter, George D.	Elgin, Ill.
WOI	Hatfield Electric Co.	Indianapolis, Ind.	WTAU	Ruegy Battery & Electric Co.	Tecumseh, Neb.
WOK	Iowa State College	Ames, Iowa	WTAW	Agricultural & Mechanical College of Texas	College Station, Texas
WOO	Pine Bluff Co.	Pine Bluff, Ark.	WTG	Kansas State Agricultural College	Manhattan, Kan.
WOQ	Wanamaker, John	Philadelphia, Pa.	WTK	Paris Radio Electric Co.	Paris, Tex.
WOR	Western Radio Co.	Kansas City, Mo.	WTP	McBridge, George M.	Bay City, Mich.
WOS	Bamberger & Co., L.	Newark, N. J.	WWAC	Sanger Bros.	Waco, Texas
WOU	Missouri State Marketing Bureau	Jefferson City, Mo.	WWAD	Wright & Wright, Inc.	Philadelphia, Pa.
WOZ	Metropolitan Utilities District	Omaha, Neb.	WWAH	General Supply Co.	Lincoln, Neb.
WPA	Palladium Printing Co.	Richmond, Ind.	WWAX	Worman Bros.	Laredo, Tex.
WPAB	Fort Worth Record	Fort Worth, Texas	WWAY	Marigold Gardens	Chicago, Ill.
WPAC	Penn. State College	State College, Pa.	WWB	Daily News Printing Co.	Canton, O.
WPAD	Donaldson Radio Co.	Okmulgee, Okla.	WWI	Ford Motor Co.	Dearborn, Mich.
WPAF	W. A. Wieboldt & Co.	Chicago, Ill.	WWJ	Detroit News	Detroit, Mich.
WPAG	Peterson's Radio Co.	Council Bluffs, Iowa	WWL	Loyola University	New Orleans, La.
WPAH	Central Radio Co., Inc.	Independence, Mo.	WWT	McCarthy Bros. & Ford	Buffalo, N. Y.
WPAJ	Wisconsin Dept. of Markets	Waupaca, Wis.	WWZ	Wanamaker, John	New York, N. Y.
WPAK	Doolittle Radio Corporation	New Haven, Conn.	CFAC	Radio Corp. of Calgary, Ltd.	Calgary, Alberta
WPAL	North Dakota Agricultural College	N. D.	CFCA	Star Pub. and Printing Co.	Toronto, Ontario
WPAN	Superior Radio & Tel. Equipment Co.	Columbus, Ohio	CFCB	Marconi Wireless Telegraph Co. of Canada, Ltd.	Vancouver, B. C.
*WPAM	Auerbach & Guettel	Topeka, Kans.	CFCD	Canadian Westinghouse Co., Ltd.	Winnipeg, Manitoba
WPAP	Levy Bros. Dry Goods Co.	Houston, Texas	CFCE	Marconi W. T. Co. of Canada	Halifax, N. S.
WPAQ	Theodore S. Phillips	Winchester, Ky.	CFCF	Marconi W. T. Co. of Canada, Ltd.	Montreal, Quebec
WPAR	General Sales & Engr. Co.	Frostburg, Md.	CFCH	Abitibi Power and Paper Co., Ltd.	Iroquois Falls, Ontario
WPAS	R. A. Ward	Beloit, Kan.	CFCI	Motor Products Corp.	Walkersville, Ontario
WPAT	J. & M. Electric Co.	Amsterdam, N. Y.	CFCN	W. W. Grant Radio, Ltd.	Calgary, Alberta
WPAU	Saint Patrick's Cathedral	El Paso, Texas	CFCX	The London Advertiser	London, Ontario
WPAV	Concordia College	Moorhead, Minn.	CFPC	International Radio Development Co.	Fort Frances, Ontario
WPAW	Tinetti & Sons, Paul	Laurium, Mich.	CFTC	The Bell Telephone Co. of Canada	Toronto, Ontario
WPAX	Radio Installation Co., Inc.	Wilmington, Del.	CFUC	University of Montreal	Montreal, Quebec
WPAY	S—W Radio Co.	Thomasville, Ga.	CFVC	Roy Russell Brown	Courtenay, British Columbia
WPB	Bangor Radio Laboratory	Bangor, Maine	CFYC	Victor Wentworth Odium	Vancouver, B. C.
*WPZ	Koch, Dr. John R.	Charleston, W. Va.	CHAC	Canadian Westinghouse Co., Ltd.	Montreal, Quebec
WPB	Newspapers Printing Co.	Pittsburgh, Pa.	CHBC	Radio Engineers, Ltd.	Nova Scotia, Halifax
*WPG	Central Radio Co.	Kansas City, Mo.	CHCA	The Albertan Publishing Co.	Calgary, Alberta
WPI	Nushawg Poultry Farm	New Lebanon, O.	CHCB	Radio Corp. of Vancouver, Ltd.	Vancouver, B. C.
*WPI	Electric Supply Co.	Clearfield, Pa.	CHCC	Marconi W. T. Co. of Canada, Ltd.	Toronto, Ontario
*WPI	St. Joseph's College	Philadelphia, Pa.	CHCF	Canadian Westinghouse Co., Ltd.	Edmonton, Alberta
WPL	Fergus Electric Co.	Zanesville, O.	CHCQ	Radio Corp. of Winnipeg, Ltd.	Winnipeg, Manitoba
WPM	Williams, Thomas L.	Washington, D. C.	CHCS	The Western Radio Co., Ltd.	Calgary, Alberta
WPO	United Equipment Co.	Memphis, Tenn.	CHCX	London Radio Shoppe	London, Ontario
WQAA	Horace A. Beele, Jr.	Parkersburg, Pa.	CHCZ	B. L. Silver	Montreal, Quebec
WQAB	Southwest Missouri State Teachers' College	Springfield, Mo.	CHFC	The Globe Printing Co.	Toronto, Ontario
WQAC	Gish, E. B.	Amarillo, Texas	CHIC	John Millen & Sons, Ltd.	Toronto, Ontario
WQAD	Whitall Electric Co.	Waterbury, Conn.	CHOC	Canadian Westinghouse Co., Ltd.	Hamilton, Ontario
WQAE	Moore Radio News Station	Springfield, Vt.	CHOC	Canadian Westinghouse Co., Ltd.	Vancouver, B. C.
WQAF	Sandusky Register	Sandusky, O.	CHVC	Metropolitan Motors, Ltd.	Toronto, Ontario
WQAH	Brock-Anderson Elect. Eng. Co.	Lexington, Ky.	CHXC	J. R. Booth, Jr.	Ottawa, Ontario
WQAJ	Ann Arbor Times News	Ann Arbor, Mich.	CHYC	Northern Electric Co.	Montreal, Quebec
WQAK	Appel-Higley Electric Co.	Dubuque, Iowa	CJBC	Dupuis Freres	Montreal, Quebec
WQAL	Cole County Tel. & Tel. Co.	Mattoon, Ill.			
WQAM	Electrical Equipment Co.	Miami, Fla.			
WQAN	Scranton Times	Scranton, Pa.			
WQAO	Calvary Baptist Church	New York, N. Y.			



# 3 Letters! and they will be interesting to every — radio user.

**HUDSON MOTOR CAR COMPANY OF N.Y.**

**HUDSON AND ESSEX MOTOR CARS**  
1422 BEDFORD AVE.  
BROOKLYN

November 23rd, 1922

Acme Apparatus Company  
Cambridge, Mass.

Gentlemen:—

It will possibly be of interest to you to know that with the aid of your radio Frequency Transformers R2, R3 and R4, I have built an ideal set. This set brings in PWX, Havana, as clear as a bell any time that I care to hear him. I have also reached other stations that I never knew existed. Last night I hooked up 3 Transformers in place of yours, and with the stations that I received there was enough howls and yells to make one think that all Hell was let loose at once, so put the old Acme's back and the loud speaker started to give out some real music. This set has given such satisfaction that I simply couldn't refrain from writing you to let you know that you have satisfied at least one Radio Bug. However, I might add that I am using a loop antenna and my tuner consists of only 2 Variable condensers, one 43 plate and one 3 plate hooked right across the loop outlet.

Please do not think that this is the first set I have ever seen and that my enthusiasm is running away with me. I have owned a . . . a step and a . . . and have also built numerous other sets, but this Acme Radio Frequency Transformer sure has the world licked.

Very truly yours,

Hudson Motor Car Company of N. Y., Inc.



Service Manager

YOU can purchase all Acme Transformers at radio stores. If your dealer does not carry them, we will see that you are taken care of. Leaflets describing hook-ups for various Acme Transformers will be sent on request.

**THE ACME APPARATUS COMPANY**

*(Pioneer transformer and radio engineers and manufacturers.)*

CAMBRIDGE, MASS., U. S. A.

New York  
Chicago

1270 Broadway  
184 W. Washington Street

**ACME APPARATUS COMPANY**

TRANSFORMER RADIO ENGINEERS & MANUFACTURERS

186 MASSACHUSETTS AVENUE  
CAMBRIDGE 28, MASS., U. S. A.

Mr. John M. Craig  
510 St. Marks Avenue  
Brooklyn, N. Y.

December 7th, 1922

Dear Sir:—

We wish to thank you for your letter of November 23rd and would like to know if you would be willing to allow us to use this as a testimonial either with or without your name.

We worked for practically nine months before putting a radio frequency amplifying transformer on the market and it is exceedingly gratifying to receive such letters as yours as a reward for this endeavor.

Yours very truly,

ACME APPARATUS COMPANY



Per Chief Engineer

**HUDSON MOTOR CAR COMPANY OF N.Y.**

**HUDSON AND ESSEX MOTOR CARS**  
1422 BEDFORD AVE.  
BROOKLYN

Mr. G. E. M. Bertram  
186 Massachusetts Ave.,  
Cambridge, Mass.

December 8th, 1922

Dear Sir:—

Your letter of the 7th instant came to hand this morning, and in reply would say that you are at liberty to use my letter of November 23rd, in any way you desire, with or without my name. I might add that I know of four sets copied from mine that are giving results equal to mine.

On Wednesday evening I had a transmission engineer from the New York Telephone Company out to my home and believe me he was the most surprised man I have seen in some time. Without having ever seen my set, in twenty minutes he tuned in PWX, WOC, WBAP, WSB and several near stations. What pleased him especially was that he could tune in the 200 meter stations as well as the 400 meter boys.

Very truly yours,

Hudson Motor Car Company of N. Y., Inc.



Service Manager

JMC:N  
510 St. Marks Avenue  
Brooklyn, N. Y.

# ACME for amplification

★ Tested and approved by RADIO BROADCAST ★

CJCA	The Edmonton Journal, Ltd.,	Edmonton, Alberta	CJSC	The Evening Telegram	Toronto, Ontario
CJCB	James Gordon Bennett	Nelson, British Columbia	CKAC	La Presse Publishing Co.	Montreal, Quebec
CJCD	T. Eaton Co., Ltd.	Toronto, Ontario	CKCB	T. Eaton Co., Ltd.	Winnipeg, Manitoba
CJCE	Vancouver Sun Radiotelephones, Ltd.	Vancouver, B. C.	CKCD	Vancouver Daily Province	Vancouver, B. C.
CJCF	News Record, Ltd.	Kitchener, Ontario	CKCE	Canadian Independent Tel. Co., Ltd.	Toronto, Ontario
CJCG	Manitoba Free Press Co., Ltd.	Winnipeg, Manitoba	CKCK	Leader Publishing Co., Ltd.	Regina, Saskatchewan
CJCH	The United Farmers of Ontario	Toronto, Ontario	CKCR	Jones Electric Radio Co.	St. John, New Brunswick
CJCI	McLean, Holt & Co., Ltd.	St. John, New Brunswick	CKCS	The Bell Telephone Co. of Canada	Montreal, Quebec
CJCN	Simons Agnew & Co.	Toronto, Ontario	CKCZ	Canadian Westinghouse Co., Ltd.	Toronto, Ontario
CJCS	Eastern Tel. and Tel. Co., Ltd.	Halifax, Nova Scotia	CKKC	Radio Equipment and Supply Co.	Toronto, Ontario
CJCY	Edmund Taylor	Calgary, Alberta	CKOC	The Wentworth Radio Supply Co.	Hamilton, Ontario
CJGC	London Free Press Printing Co., Ltd.	London, Ontario	CKQC	Radio Supply Co. of London	London, Ontario
CJNC	Tribune Newspaper Co., Ltd.	Winnipeg, Manitoba	CKZC	Salton Radio Engineering Co.	Winnipeg, Manitoba

## THE GRID

(Continued from page 79)

tion seldom desirable in receiving other than continuous wave signals.

However, as the grid or secondary circuit is of course in resonance with the primary, the set is theoretically more efficient when the plate circuit is likewise in perfect tune with the received wave, i.e., each and every circuit is co-operating to make the most of the energy picked up by the antenna. As before explained, it is impracticable to realize this condition often (except in super-regeneration) due to the circuit falling into an oscillating state; but the experienced operator effects a compromise by slightly lowering the filament, and continuing to tune the plate circuit toward resonance. A happy medium resulting in the loudest signals may be thus achieved, when the plate circuit is almost resonant, and the detector filament lowered *just enough to prevent oscillations without impairing the efficiency of the tube*. Needless to say, the life of the bulb is prolonged by this finesse.

The phenomena of tickler and variometer regeneration were explained in detail in the December GRID.

Regeneration in the De Forest ultra-audion circuit can be controlled, but to a lesser degree than is possible in variometer and tickler circuits. Control is principally effected by the coupling condenser between the plate and filament. In many cases the oscillations may be rendered less critical by varying the grid leak, grid condenser, filament rheostat or a B battery potentiometer.

Whatever advantage exists in a circuit combining both tickler and variometer regeneration is counteracted by the critical and unstable operation. However, some amateurs, familiar with the idiosyncrasies of the circuit, have experienced phenomenal results using a three coil (primary, secondary and tickler) honeycomb set, with variometers in the grid and plate circuits.

A very effective combination of tuned plate and tickler feed-back can be easily secured by shunting the tickler coil (a half dozen or so turns under the normal size) by a twenty-three plate variable condenser.

### ARTIFICIAL STRAYS

*We are troubled here with a Cotterell dust precipitating plant at the smelter, and so far it has been impossible to use a receiver on account of the Cotterell making more noise than the incoming signals. However, I think, perhaps, that a radio-frequency outfit may work through this. What are your ideas?*

—W. H. M., MIAMI, ARIZONA.

DUST precipitating arrangements, as well as those for the elimination of heavy factory smoke, operate on the principle of the electrical attraction and repulsion of charged conductors on small particles, such as dust and carbon (smoke). Many achieve this effect by means of high potentials which, continually breaking down in the process of charging the microscopic matter, set up radio waves. Nearby X-ray and high-frequency apparatus causes similar QRM (interference), as well as do radio-frequency machines for the cultivation of plants and gardens. These last consist primarily of an antenna suspended over a ground (the area under cultivation) and create such an atmospheric disturbance that they have attracted government attention. It is contended by some that the agricultural enterprise is no other than a radio station transmitting without a license, and should be prosecuted as such!

Radio-frequency amplification will doubtless be helpful in almost every case, and in many instances will eliminate such artificial static.

If the disturbance is of audio frequency, due to powerful primary and secondary, and inductively coupled receiver (one having the audion and the antenna system) will help matters, and radio-frequency amplification, which is nothing more than additional couplers, will silence the last undesired crash.

If the interference is in the form of a wireless wave, the solution is more difficult, and next to impossible when the predominant wave of the interfering signal is that which it is desired to receive. There is generally a certain frequency (or wave) in all radio oscillations which carries most of the power. However, due to broadness of the wave (or proximity of the station, in which case oscillations are forced on almost any frequency) the signals, though loudest at the resonant or predominant point, will be heard on more than one degree of the tuning scale. This resonant point may be determined by merely tuning over the range of the set, and noting where the signals are of the greatest intensity. If this wavelength is other than that which it is desired to receive, radio-frequency amplification will help matters, each step acting as a filter, passing and amplifying the genuine signal, but discriminating against the pirating stray.

Engineers might consider this matter, and design dust precipitating and similar apparatus, so that the emitted wave is predominantly of a non-interfering frequency.

The wireless world is beginning to appreciate the possibilities of radio frequency!



Paul Godley on "Choosing Your Regenerative Circuit"

# RADIO BROADCAST

June, 1923

7.13 - 2  
The Search for a Telephone as Sensitive as the Ear

Operating a Loud Speaker on One Tube,  
Without Batteries

Radio in Summer Camps

The Best Battery Connections  
for the Set You Use

All Boy Scouts, Attention!

Learning the Code

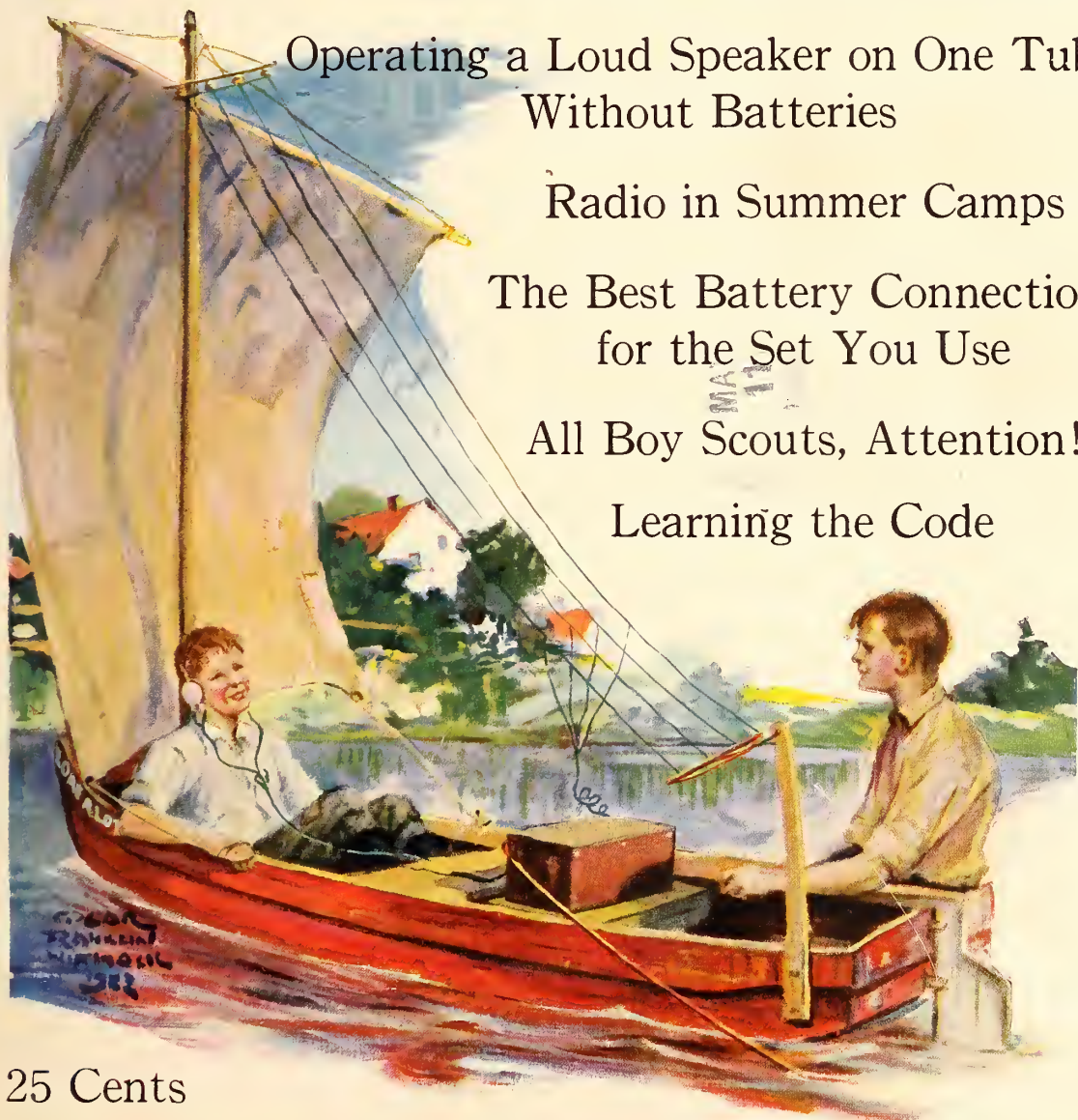

25 Cents

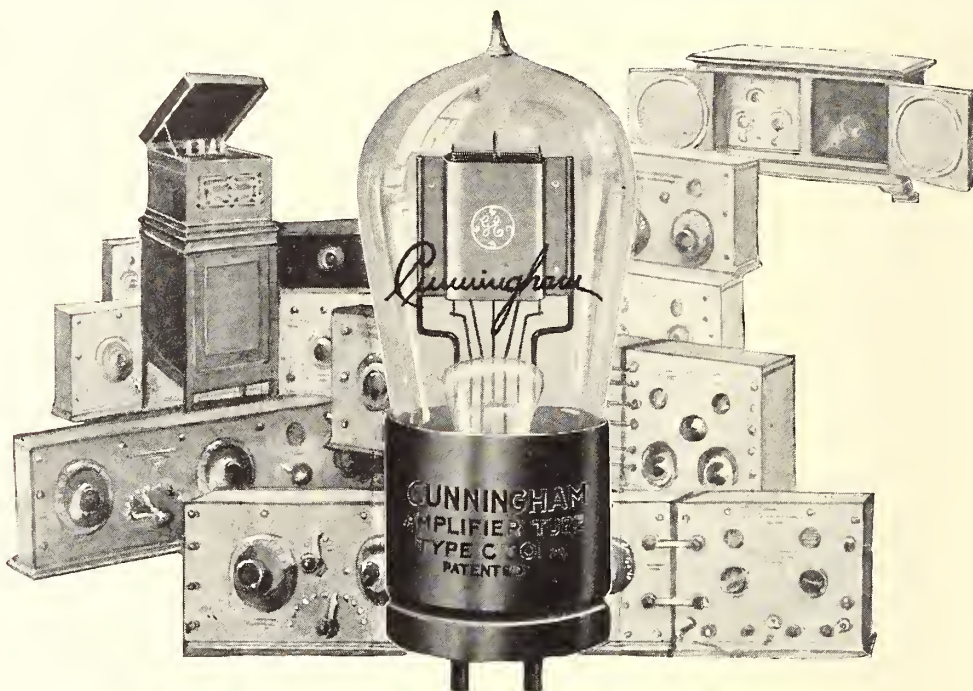

# Cunningham

*the standard tube for all makes of receiving sets*

## Mutual Conductance

### The Correct Rating for Vacuum Tubes

Gas Engines are rated by their horsepower—Electric Generators are rated by their watt or kilowatt output—Mazda Lamps are rated by their candle-power. All of these factors actually express the efficiency of the article for the purposes intended.

In the past vacuum tubes have been known merely as Detectors and Amplifiers. These terms indicated only the use for which the tube was designed, but in no way expressed its efficiency for either of these purposes. Though little known to the general public, there is a factor—MUTUAL CONDUCTANCE—which adequately and accurately expresses the efficiency of vacuum tubes. The new Cunningham C-301-A has the *highest value of mutual conductance ever obtained in a receiving tube*, and it is this factor that is responsible for its *superior operation* as an Amplifier.

Write for Bulletin 1-B explaining the uses and advantages of the term Mutual Conductance as the correct rating for Vacuum Tubes

### Cunningham C-301-A Improved Amplifier Now \$6.50

Filament Current  $\frac{1}{4}$  Amp. Mutual Conductance—600 micromhos at 100 volts plate and 6 volts neg. grid potential

#### Patent Notice:

Cunningham tubes are covered by patents dated 11-7-05, 1-15-07, 2-18-08, and others issued and pending. Licensed for amateur, experimental and entertainment use in radio communication. Any other use will be an infringement.

*E. J. Cunningham*

Home Office:  
248 First Street  
San Francisco, Calif.

For the assistance of the public, in obtaining true musical quality and actual reproduction in broadcast reception, this company will, from time to time, issue Service Bulletins explaining in a clear and simple manner the most important technical features that must be observed in the selection and operation of radio apparatus.

Cunningham Service Bulletin No. 1 explains the use of the factor mutual conductance as the standard rating for vacuum tubes. The information it contains should be thoroughly known to every owner of a radio set who is interested in obtaining maximum efficiency with a given number of vacuum tubes. This bulletin will be mailed to you, free of charge, upon request.



The trade mark GE is the guarantee of these quality tubes. Each tube is built to most rigid specifications.

Eastern Representative:  
154 West Lake Street  
Chicago, Illinois



**CROSLLEY**  
BETTER COST LESS  
**RADIO**  
PRODUCTS

"WLW BROADCASTING STATION  
**CROSLLEY**  
MFG., CO.,  
CINCINNATI, O."

**THE HEIGHT OF EFFICIENCY**  
*Crosley Model X, Price, \$55.* ★

Clearly, distinctly, as though given in the same room, messages from WLW Broadcasting Station, Crosley Mfg. Co., Cincinnati, are heard in all parts of America if a Crosley Model X—a four tube radio frequency set—is used. This remarkable instrument, very easy to tune, simple and beautiful in construction, has repeatedly brought in messages over 4900 miles away.

Other Crosley Models, like the Model VIII, three tube set—price \$48, and the Model VI, two tube set—price \$28, have given exceptional results to thousands of satisfied users everywhere.



Write For Catalogue Showing Complete Crosley Line.  
*For Sale By Best Dealers Everywhere*

Besides a complete assortment of receivers, Crosley manufactures parts for replacement or home construction.

Jobbers and Dealers Will be Interested in the Crosley Proposition.



*New York Office:*  
C. B. COOPER,

1803 Tribune Bldg., 154 Nassau St.

*Boston Office:*  
B. H. SMITH,

929 Blue Hill Ave., Dorchester

*Chicago Office:*  
R. A. STEMM, Mgr.

1311 Steger Bldg., 28 E. Jackson Blvd.

**CROSLLEY MANUFACTURING COMPANY**  
620 ALFRED ST. CINCINNATI, OHIO

**Remarkable  
Regenerative  
Receivers**

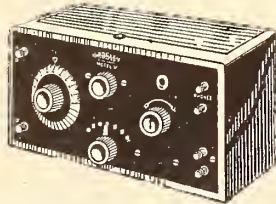

**ACE Model V**  
**\$20** ★

*Formerly known as  
CROSLLEY MODEL VC*

This one tube receiver is astounding the radio world with its wonderful achievements. Stations more than 1000 miles away are being regularly copied on this set. In comparison to its price, there is no receiver on the market to-day to equal it in performance.

Because of its size and price the Ace Model V is a great summer seller.

Licensed under Armstrong U. S. Patent No. 1,113,149.

Live Jobbers and Dealers are eagerly taking advantage of the sales this instrument and the rest of the Precision instruments and parts bring them.

*Free Catalogue on Request*

**THE PRECISION EQUIPMENT CO.**  
*Powel Crosley Jr. President*

620 GILBERT AVE.

CINCINNATI, OHIO

# Radio Broadcast

ARTHUR H. LYNCH, EDITOR



## CONTENTS FOR JUNE, 1923

<i>Not a Soul Aboard—Controlled by Radio</i> . . . . .	<i>Frontispiece</i>
THE MARCH OF RADIO. . . . .	91
RADIO IN SUMMER CAMPS . . . . .	ELON JESSUP 102
OPERATING A LOUD SPEAKER ON ONE TUBE WITHOUT BATTERIES WALTER VAN B. ROBERTS	108
A STORMY P. M. AT ALICE'S . . . . . Drawings by Thomas E. Monroe	WILLARD WILSON 112
LEARNING THE CODE . . . . .	WILLIAM HARRIS, JR. 114
IS SHORT-WAVE RELAYING A STEP TOWARD NATIONAL BROADCASTING STATIONS? . . . . .	W. W. RODGERS 119
THE BEST BATTERY CONNECTIONS FOR THE SET YOU USE EDWARD LINDLEY BOWLES	123
A MAN WHO BUILT A SET HE HAS NEVER SEEN . . . . .	ALFRED M. CADDELL 128
A LOOP RECEIVER IN THE TROPICS . . . . .	CHARLES T. WHITEFIELD 133
WITH THE BROADCASTERS . . . . .	135
PROTECTING YOUR INVENTION . . . . .	ROGER SHERMAN HOAR 136
THE SEARCH FOR A TELEPHONE AS SENSITIVE AS THE EAR GEORGE B. CROUSE	142
CONCERTS FOR ALL IN A VETERANS' HOSPITAL. . . . .	J. TOWNSEND BRADLEY 147
ADVENTURES ON AN AMERICAN YACHT IN MEXICO . . . . . Drawings by Thomas E. Monroe	A. HENRY 149
CHOOSING YOUR REGENERATIVE CIRCUIT . . . . .	PAUL F. GODLEY 154
INTERNATIONAL LAW AND THE SEA-GOING TELEGRAPHER CLAUDE CATHCART LEVIN	159
SOLDERING YOUR OWN . . . . .	W. S. STANDIFORD 161
THE BROADCAST RECEIVING CONTEST—RULES AND PRIZES . . . . .	164
A BIT ABOUT BOOKS . . . . .	165
ALL BOY SCOUTS, ATTENTION! . . . . .	166
NEW WAVELENGTHS FOR CLASS B STATIONS . . . . .	167
ADDITIONAL BROADCASTING STATIONS IN THE UNITED STATES . . . . .	168
THE GRID—QUESTIONS AND ANSWERS . . . . .	170
NEW EQUIPMENT . . . . .	176

Copyright, 1923, by Doubleday, Page & Co. All rights reserved  
TERMS: \$3.00 a year; single copies 25 cents

F. N. DOUBLEDAY, Pres.

RUSSELL DOUBLEDAY, Sec'y.

ARTHUR W. PAGE, Vice-Pres.

S. A. EVERITT, Treas.

NELSON DOUBLEDAY, Vice-Pres.

JOHN J. HESSIAN, Asst. Treas.

## DOUBLEDAY, PAGE & CO.

THE WORLD'S WORK COUNTRY LIFE THE GARDEN MAGAZINE SHORT STORIES EDUCATIONAL REVIEW

CHICAGO: People's Gas Bldg.

GARDEN CITY, N. Y.

NEW YORK: 120 W. 32nd Street

BOSTON: Tremont Bldg.

LOS ANGELES: Van Nuys Bldg.





# Don't Tear 1923 in Half

How a loop and Acme for amplification make radio a pleasure the whole year round

IS YOUR radio set good for just about six months of the year? Do you want to find a way to get distant stations clearly and distinctly the entire year; to get these stations without the usual amount of interference from government and other spark transmitting stations, from your neighbor's radiating receiving set, or from our old foe "summer static"? Then here's a way.

### Use a loop and Acme for amplification

Tear down your antenna, put on a loop and use Acme for amplification (preferably with dry battery tubes) and reduce your interference troubles to a minimum. By using Acme for amplification you get more than mere amplification—you get distance and volume without distortion. There's the Acme Radio Frequency Amplifying Transformers (R-1-2-3-4) for distance and the Acme Audio Frequency Amplifying Transformer A-2 for volume, and the Acme Kleerspeaker for clearness. Use Acme in the set you buy. You can buy this standard Acme Apparatus at any radio or electrical store.

A special booklet has just been prepared explaining exactly how to avoid interference and to secure distant stations clearly and distinct-

ly. The booklet includes wiring diagrams and other serviceable information. It will be sent postpaid anywhere in the United States, Canada or Mexico on receipt of ten cents or its equivalent in American money. This small charge is made in order to be certain that the booklet is placed in the hands of radio owners and experimenters and that it will not be wasted upon mere curiosity seekers. The coupon is for your convenience.

### ACME APPARATUS COMPANY

(Pioneer radio engineers and manufacturers)

Cambridge Mass., U. S. A.

#### SALES OFFICES IN PRINCIPAL CITIES

New York Chicago Cleveland  
 1270 Broadway 184 W. Washington St. 3707 Euclid Ave.  
 Kansas City San Francisco  
 208 Baltimore Bldg. 267 Minna St.

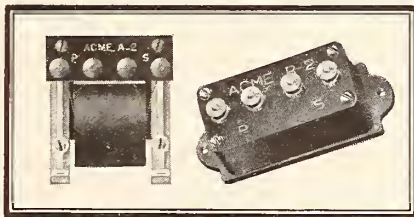

Acme A-2 Audio Frequency and Acme R-2 Radio Frequency Amplifying Transformers. Price \$5 east of Rocky Mountains.

ACME APPARATUS CO.  
 Cambridge, Mass., U. S. A.

Gentlemen—Enclosed find 10 cents in (coin), (stamps), for which send me your booklet on wiring diagrams and complete information on Acme Apparatus.

Name.....  
 Street.....  
 City.....  
 State.....

# ACME <sup>★</sup> for amplification

★ Tested and approved by RADIO BROADCAST ★



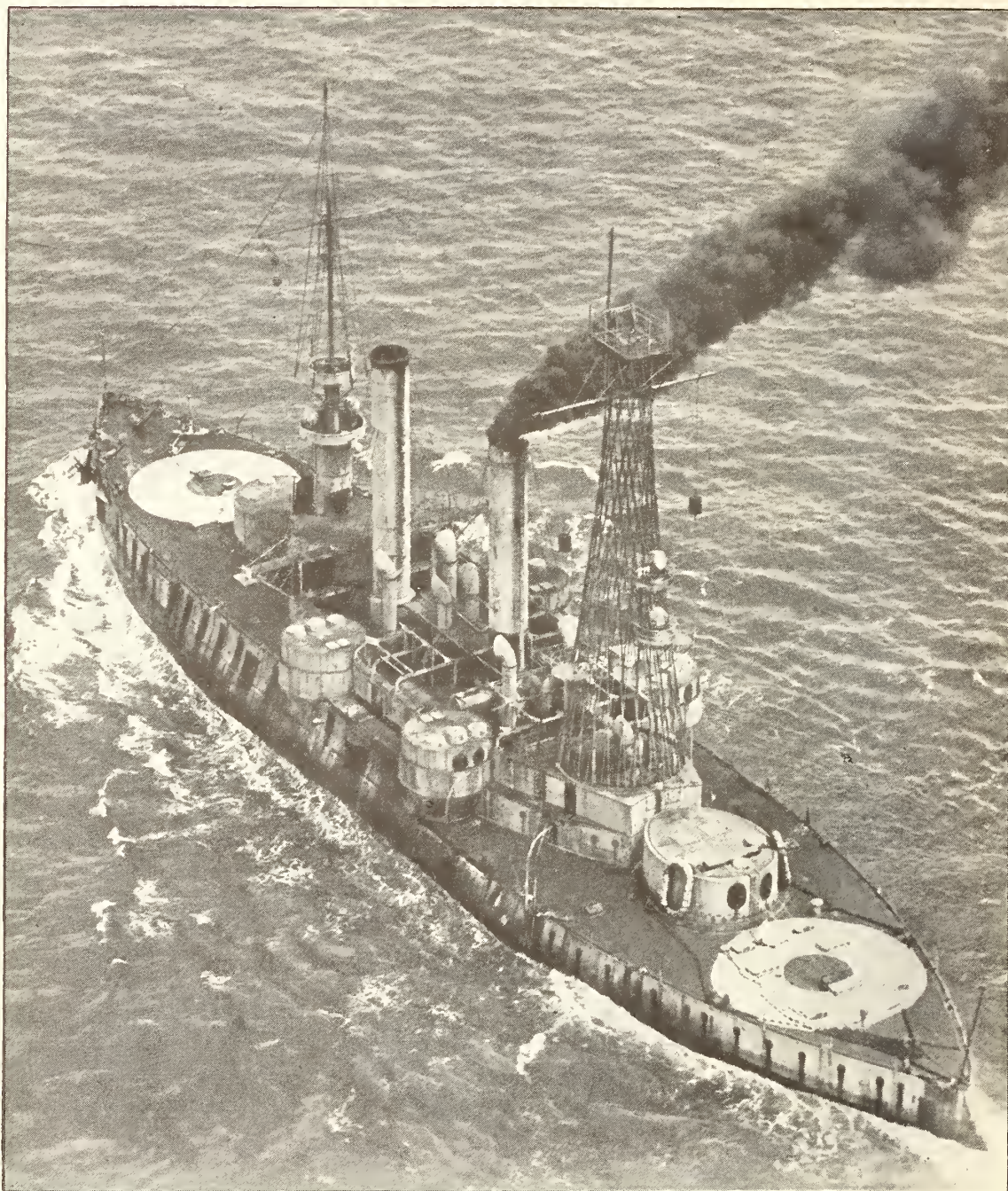

NOT A SOUL ABOARD—CONTROLLED BY RADIO

The old U. S. S. *Iowa*, picked as the moving target, in the recent maneuvers off Panama, for the big guns of the super-dreadnought, *Mississippi*. She was guided on her final trip by a delicate system of radio controls. Early in the "battle," this apparatus aboard the *Iowa* was put out of commission, and she was sent to the bottom in quick time, it being no longer possible for her to evade the enemy fire



# RADIO BROADCAST

Vol. 3 No. 2



June, 1923

## The March of Radio

### OUTDOOR EXPERIMENTING IN VACATION-TIME

**E**VERY man is endowed to a greater or less degree with the spirit of research—the spirit which urges him to investigate, for himself, the region of the unknown. It is probably this desire to know new things, to investigate fields as yet unexplored, more than any other of his characteristics which has differentiated man from the other animals. None of the higher anthropoids has been known to show curiosity about the use of iron ore, for example: to him it remains the same as any other dirt; but to man, who noticed its changes when heated in a fire, it became the source of steel, the basis of our industrial life.

Whereas the research accomplishments of but few men are written upon the pages of progress, it is undoubtedly true that any normal man from childhood up likes to “see what will happen” as a result of conditions he controls. For most of us, however, research must occupy a minor rôle, as the routine accomplishment of the ordinary prosaic tasks must necessarily use most of our time and energy. To him who is more than ordinarily gifted with the spirit of investigation the life of the real research worker—who year after year as his sole occupation pursues the unknown—must seem like one long journey through Elysian fields.

The office or factory tasks seem very unattractive when compared to this work carried out in the spirit of “I must find out.” Although the large industrial companies are very

rapidly expanding their research staffs and laboratories, there can never be more than a very small percentage of us actually engaged in research work as a profession. The labor of the researcher must be supported by the more matter-of-fact jobs of the factory and office worker. Most of the research men’s labors bring forth nothing new of material value, so that it is a foregone conclusion that most of us must be content to perform our routine tasks efficiently to support the researcher, and we must satisfy our investigating spirit by imaginative trips or by reading of the work accomplished by others.

The general interest in radio has brought thousands of us closer to a new and unexplored field than we had thought possible, and in this field we can labor to our heart’s content, for the cost of the apparatus is generally within our means and the corner of the living room suffices for a laboratory. That radio does serve as an outlet for the “I’d like to know” spirit of thousands can be judged by the conversation of young and old as they compare notes on their way to and from work. Hundreds of thousands of people to-day are wondering *why* something happens who would not have had their imaginations excited had it not been for radio. Each night sees a new connection tried, new types of apparatus substituted for old, and subsequent comparison of notes with a pal who has been trying something else.

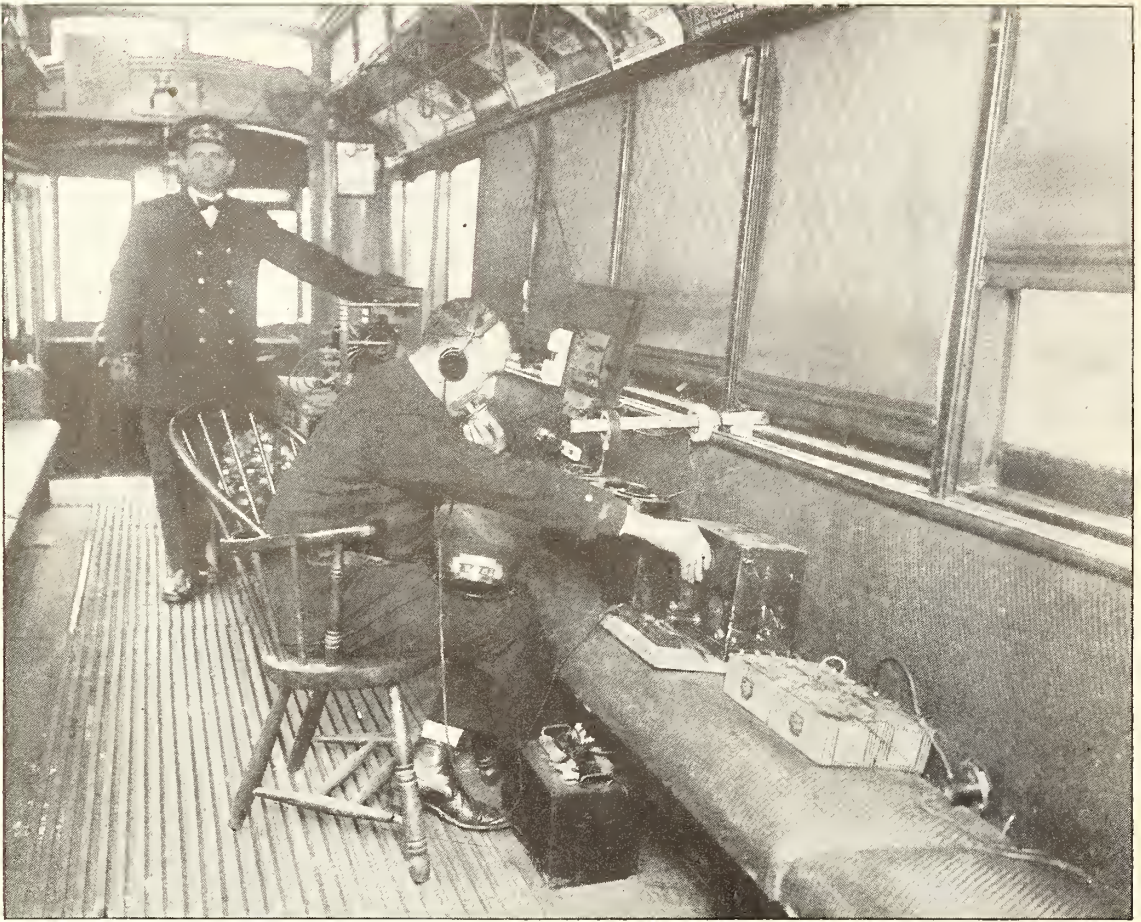

#### EXPERIMENTING WITH RADIO TELEPHONY IN A NEW YORK TROLLEY CAR

The Third Avenue Railway Company, in conjunction with the General Electric Company, has completed a series of experiments wherein radio carrier currents and trolley wires of its overhead system as a means of communication between points on the system. The transmitters and receivers are similar in many respects to the general run of broadcasting outfits and satisfactory communication has been established between substations and dispatchers' offices and the trolleys. Since the receiving point may be at any point along the line, emergency calls will reach their destination in record time and the exact nature of the apparatus needed to remedy whatever troubles may develop will be transmitted. In this way, operating delays will be reduced to a minimum. Conductor George Dwyer is shown trying out the new apparatus

All the good things in radio haven't yet been discovered. To be sure, regeneration and heterodyne reception cannot be re-discovered and their rich rewards again be obtained, but who knows what still more interesting and valuable ideas are hidden, awaiting some investigator's disclosure? According to the theory of probability, perhaps not more than one in a hundred thousand listeners will discover something which is commercially worth much, but the fun and exhilaration of testing and experimenting is open to all, and this kind of work is in itself sufficient reward.

It is not ordinarily possible to carry out tests on our antennas, as the local conditions generally fix their installation, but with the coming of

summer and vacations and auto tours, a fascinating field of work is opened for the radio enthusiast. How does a signal decrease in intensity as the distance from the transmitting station increases? Does it decrease as rapidly if we stay near a large river as if we move over country away from it? How far will a crystal set receive? Does ground resistance really have much to do with the strength of a signal? Let's try it by grounding our antenna right in the stream by which we are camped and by laying a counterpoise wire on the dry ground, or by using the automobile frame as ground, this being well insulated from ground by the tires. Is a single wire antenna actually as directional as "everybody says?" It will be easy to find



out by stringing the antenna to different trees in different directions with respect to the transmitting station. Is the radio compass a reliable way of locating a radio station, or does the presence of streams, ocean shore, etc. greatly affect its accuracy? Using loop antenna, maps, and a magnetic compass, the tourist may answer the question for himself. Is there really a detrimental effect caused by trees around the receiving antenna? It's perfectly simple to find out by trying.

While the answer to these questions, even if reliably obtained, will not materially enrich the experimenter, the "finding out" will prove interesting and fascinating to the average man and the work (or play) involved in determining the answer will be well worth while. So let radio increase the pleasure and profit derived from this summer's trips—take the radio set along with you so that you can experiment when the urge is upon you, and when the set is not being used for experimenting it will keep you in touch with your favorite stations

and make the evenings more pleasurable to you and to the others who will be sure to visit the tourist who has his radio along.

### Hoodwinking the Listeners-In

IT was not long ago that we called to the attention of those who make up the programs of the broadcasting stations their responsibility to the radio public for the material sent out. Programs are generally made up some weeks in advance so that the excuse of "no time" cannot be offered in extenuation. Managers must assume the same responsibility for the quality of the material sent out from their



© Underwood & Underwood

#### SIR BASIL THOMSON BROADCASTING HIS FAREWELL TO AMERICA

The former Director of the Special Branch (detective division) of Scotland Yard giving from WJZ's Waldorf Astoria studio, in New York, his last talk before sailing for the Bahamas

station as the average commercial house does for the goods purchased through it. If the material to be broadcasted lies outside the realm of knowledge of the manager, he should call to his assistance some acknowledged authority who can vouch for the reliability of the lecture. But it would seem that for talks on radio matters the manager himself should assume the responsibility. We wonder why an attempt to hoodwink the listening public as to the possibilities of the crystal receiver was recently permitted. "Operating a loud speaker from a crystal set"—any manager who thinks that possible should give up his job and take one speculating in oil or some other field where his





TRANSMITTING RADIO MESSAGES WITH THE TELETYPE MACHINE

Chief Gunner J. J. Delaney, at the naval radio station, Washington, has only to press the keys as if using an ordinary typewriter: the letters, automatically "put on the air" as radio code symbols, are instantaneously decoded again at the receiving station by a machine which also prints them, "in English," exactly as they are sent

imagination will have sufficient play. A crystal set alone could not possibly operate a loud speaker, unless the listener was perhaps within a stone's throw of the transmitting station and even then the signal would be very poor. How then did this promoter propose to operate a loud speaker from a crystal set? By acceding to his request to write for particulars we found that it was necessary to have an ordinary audio-frequency amplifier, of the vacuum-tube type, to help the crystal!

Why the speaker was allowed to speak on this misleading topic we should like to know. Had he said that his method involved the use of ordinary triode amplifiers he would never have received the number of letters he did. The pile of letters, "more than received by any previous speaker at the station," as was announced, represented just so many radio listeners who, trusting to the judgment of the station manager, had been hoodwinked and have lost much of their faith in the accuracy of the material sent out from this station. A little of such misleading advertising goes a long

way towards spoiling the reputation of the man who so questionably advertises his goods by radio. Instead of bringing sales, such broadcast talks will eventually ruin completely the advertiser's estimate of the value of radio. Discreet advertising, which merely announces that the A. B. Company of C and D streets is offering the program for the next hour and would be pleased to receive suggestions from the radio audience as to future programs, will probably pay in the long run even though its immediate value may not be apparent; but advertising which insults the intelligence of the listener, as that on crystal sets and loud speakers, leaves a bad impression—involving not only the speaker but also the station.

#### A Big Demand for Educational Radio?

**W**ILL radio serve as an adjunct to ordinary methods of college instruction? Will the instruction given in the class room be supplemented to an appreciable degree by broadcast lectures?



There has been much talk lately by the National Radio Chamber of Commerce about helping the colleges to establish a radio broadcasting service; besides the question as to just what the Chamber can do to help in the work, the very important question must first be answered: Is there a real demand from the radio public for educational lectures of the kind given in college, class rooms?

There is undoubtedly a demand for educational material in radio broadcasting, but the demand is for the indirectly educational subjects—the kind of material one gets in listening to good musical numbers, or opera. One cannot help receiving education and inspiration from good music well rendered and there is an increasing demand for it. The managers of the broadcasting stations agree that a great percentage of their audiences prefer operatic selections to jazz. On the other hand these same managers are unanimous in their opinion that lectures of the kind and quality given in class room will not hold the radio audience.

In the class room, the gesture and personality of the instructor, and blackboard illustration, as well as the student's interest in the subject matter, serve to hold his attention. But no such advantages rest with the radio lecturer; his first phrase must capture the interest and curiosity of the listener and every sentence must be so meaty and to the point, with prediction of more interesting things to come, that there is no inclination to re-tune to a competing musical program. Neither politeness nor a desire to "stand in" with the instructor can command the interest of the radio listener—the subject matter alone must be presented in such an attractive fashion that it is considered worth while.

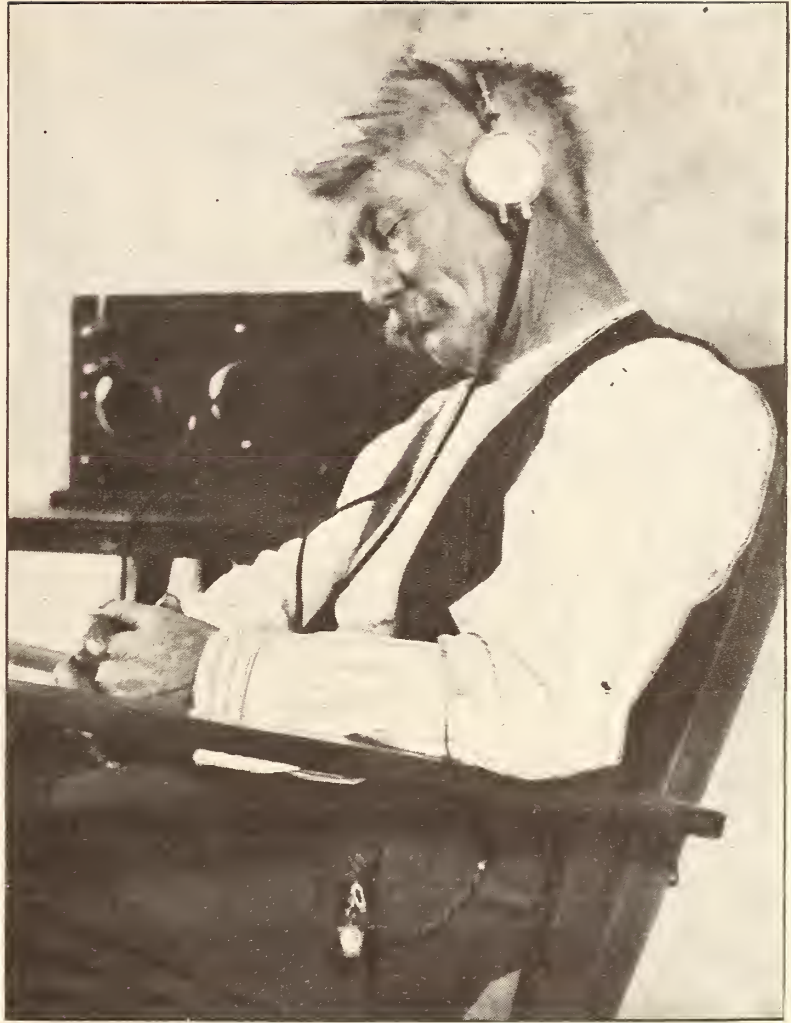

A SERMON'S A SERMON FOR ALL THAT

A glance at the quality of the pictures offered to the movie public indicates that if a demand for educational films has been made, the producers have estimated it to be of almost negligible importance. Occasionally a film with a certain amount of educational material incorporated does appear, but the meagre success of such attempts to educate the masses is evidenced by the scarcity of pictures of this kind. If there were two movie houses of equal accessibility and price, one showing some important industrial process or historical development and the other putting on the latest and hottest from Hollywood, there is no doubt whatever which house would echo with emptiness and which would need stampede regulation at its portals.

Now it may well be questioned whether the





NO HANDLE TO TURN ON THIS HURDY-GURDY

This outfit recently made its appearance on the streets of London, where all and sundry were regaled with radio melodies. Within the box is a 4-tube receiver, and two loud speakers facing in opposite directions. It is said that everyone from a newsboy to an M. P. can be stopped in his tracks at 200 yards' range when this apparatus opens up

analogy of the movies is justifiable, on the ground that the average movie audience is, in general, less particular about the quality of its entertainment than the radio audience, that the educational material which would fall flat when offered to one class would be eagerly awaited by the other. This is an hypothesis which cannot be answered at this time; but we rather question its accuracy. The only method of getting accurate information on such topics is by analyzing the correspondence received by the managers of the broadcasting stations, and it is evidently impossible to use this source of information until the experiment has been thoroughly tried out. It may well be that we shall find a sufficiently wide-spread interest in some branches of education to make it worth while, although for other branches there is no appreciable demand.

In this connection we note with interest that morning broadcasting between 11:00 A. M. and noon has met with unexpected success.

Feeling that many women would appreciate lectures of an informative nature, the Town Hall, a New York organization devoted to promoting worth while things, especially in music and literature, has started to send out through WEAF their morning lectures. From the letters received those responsible for the experiment feel well pleased. One appreciative listener writes: "I feel that it is a wonderful privilege for a busy house mother to pause for an hour and be completely 'transported' to other lands and scenes. When our tired families are home at night the radio is theirs for refreshment, but the morning is mother's own, and I for one sincerely hope that the lectures will be continued."

So do we. Here is apparently a real service for radio to perform, and we hope sufficient stations will take up the idea. It cannot be expected that the mothers will be able to get reception over thousands of miles as their young sons sometimes do in the night time when



conditions are favorable; it will be necessary for many stations well distributed, to undertake this service before it can be widely appreciated.

But this, however, is quite possible. The large department stores which most need to convince the mother of their value and desire to serve, are just the places where the broadcast stations are quite generally installed. What better way of advertising to a picked clientele? We suggest that the experiment started by the Town Hall management be taken up all over the country; the increase in cost due to running the station an hour in the morning is not great and the return might possibly be greater than it is from the more expensive evening program. It seems that not only general lectures on art and literature are suitable for such a morning program, but the courses in home economics and similar subjects which are offered in the better colleges should prove attractive to the home keepers of the country.



### The Accurate Measurement of Signals

LAST month we referred to the theory that radio waves do not travel in all directions with equal ease. After comparing statistics gathered from listeners located in various directions around a transmitting station, we have been forced to the conclusion that such is actually the case. Since we commented on this matter there has appeared a paper on the accurate measurements of radio signals, a paper prepared by three of the research engineers of the Western Electric Company. This company has had opportunities to sell hundreds of transmitting stations, but has consistently "lost" these sales when it has seemed that the intended installation was not a wise one, either from the standpoint of the purchaser or the radio public. In following out this policy the engineers have seen that it would be very necessary for them to know not only the general conditions under which the station was to be used, the wavelength, probable interference, etc., but the effect of the *location* of the station. This point had been brought home to them very forcibly by the comparatively poor performance of their own station, WBAY. Before the preliminary tests on this station

were carried out it seemed that the performance must be excellent, but actually it was disappointing. At the desired wavelength, 400 meters, the antenna system radiated poorly; at a very much longer wavelength, about 800 meters, it performed very well, the signals in the field were much louder than could possibly have been predicted.

The peculiar behavior of this antenna at once convinced the research men and designers that they must have accurate data, not guesses, on the power radiated from the antenna. How much better was the signal at 800 meters than at 400 meters? How did it vary in strength as the wavelength was varied between these limits? After a year or more of work, a measuring machine had been designed, built, and tested, which proved satisfactory. It was mounted on a truck and taken out into the field for making signal measurements on

the defective station. These tests showed conclusively that the radiated power at 800 meters was about 100 times as great as at 400 meters, whereas ordinary theory predicts it should be only one quarter as much. Theory and practice differed by a factor of 400. It was found that the station, located on the top of a sky-scraper, was using as its antenna, not the wire system which had been strung on the steel poles erected on the roof of the building, but the whole building.

Having used the measuring apparatus for the solution of this special problem it was next put to the task of measuring signal strengths at various points around transmitting stations. The apparatus, being self-contained and mounted in a small truck, could be quickly carried to any point at which it was desired to measure the signal strength. So far, it has worked only in the neighborhood of New York, but even in this limited territory it has achieved remarkable results. By making measurements at various points, in all available directions, the points all being approximately twenty-five miles from the New York station doing the transmitting, it was found that northeast of the station the electric field of the signal was only one tenth as strong as it was in a northwest direction. This means that the signal received northeast of the station would be only one hundredth as strong at an equally distant point in a westerly direction, thus confirming

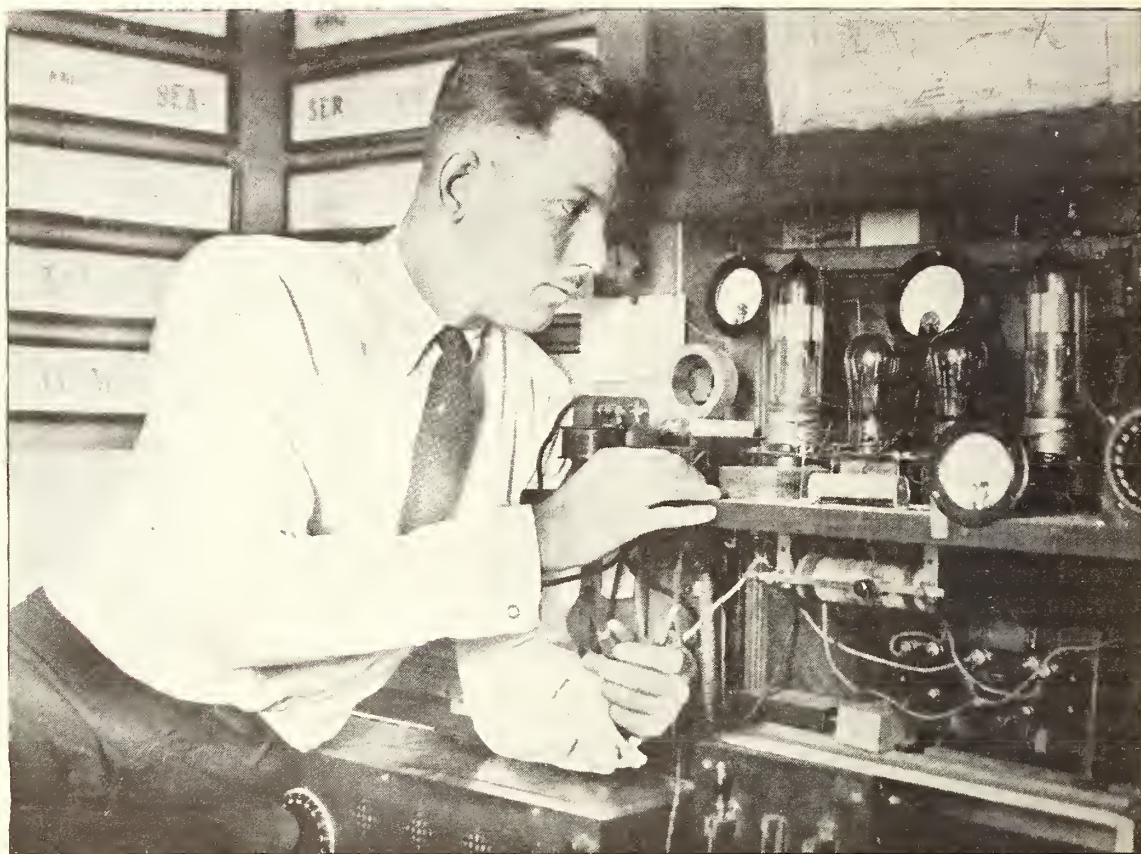

WINNER OF THE HOOVER CUP FOR THE BEST AMATEUR STATION

The Hoover cup, awarded annually to the owner of America's best amateur radio station, has been presented to Frederick R. Ostman of Ridgewood, N. J., operator of station 20M. This trophy is the highest honor in amateur radio and is awarded by the Department of Commerce through Secretary Hoover to the best all around amateur station, the major part of which is home-made. Mr. Frank Frimmerman's station, 2FZ, located in the Bronx, New York, was judged the second best amateur station. 2FZ was described and illustrated in RADIO BROADCAST for April

the decision reached by statistically comparing notes of various receiving stations at different points.

Not only in showing conclusively the trouble in existing stations but in making it possible to find a good location for a new station, this apparatus has already justified the time and expense required to develop it. By putting up a temporary antenna on the building where it was anticipated the new station was to be erected and making signal measurements in the surrounding territory it was shown that very poor results would be obtained. Not only did the results show that the building was too high to be suitable for a 400-meter station but the location of the building among neighboring sky-scrapers was such that in the direction where most of the prospective listeners were located the transmission was particularly

poor. Other temporary antennas were erected on other buildings available for the station, and the field measurements showed decisively the superiority of one of the buildings over the others.

The value of these measurements will be apparent when it is mentioned that one of these stations costs about \$25,000 to install; as these preliminary field measurements have shown the chosen site to be about five times as good as the one which would have been chosen had the measurements not been made, it is evident that they increased the effectiveness of that \$25,000 investment in the ratio of five to one. The work of the three engineers responsible for the development of this measuring apparatus—Bown, Englund, and Friis—has been well done, and they deserve the hearty thanks and congratulations of all listeners-in.



## Help the Boy Scout with His Radio

THESE is probably no doubt in any one's mind regarding the value of the Boy Scout movement. If there is, let the doubter meet one of the troops on the hike and get in conversation with the members or listen to what their Scoutmaster has to say. These healthy, wide-awake boys will soon be the leaders and backbone of the country. The development in them of the right way of living and thinking is the most worth-while work in which any one could engage. These boys' love of the outdoors will undoubtedly make them more suitable for framing and maintaining laws regulating our natural resources, a problem which will have assumed tremendous importance by the time they grow up. The spirit of fair play, with which every Scoutmaster seeks to imbue his followers, and which Scouts so generally show, is an attribute

which will go a long way toward solving the difficult economical problems of continually growing importance. From whatever angle it is viewed, the Scout movement shows up so well that no intelligent man could reasonably withhold his support.

A Scout activity which will serve the double purpose of assisting the Scoutmaster in laying out interesting tasks for his followers and of directing the boys into accurate and interesting experimental work has to do with radio. Every troop on the hike this summer should have along with it a radio outfit for listening to the distant transmitting stations. Receiving sets using dry-cell tubes are not difficult to transport, and in the hands of a skillful operator will receive hundreds of miles.

To see how quickly an antenna could be strung to a neighboring tree and the set be put into operating condition should prove an interesting addition to the Scouts' varied activi-



AN APARTMENT HOUSE STATION THAT SUPPLIES BROADCASTS TO 72 TENANTS

The landlord of a Newark, N. J., apartment house has installed a receiver in his building, which gets broadcast programs from all over the East and Middle West. Each family or tenant is a subscriber, having only to plug in phones or a loud-speaker on the line terminating in his own living-room, to receive the concerts that Operator James Walsh tunes in

ties. In case two or more sets are available, contests to see who can first get "in touch" with the outside world would be welcomed by the troop. Our purpose in writing this is not so much to interest the Scouts in radio—they are interested in it already—but to let their dads know that a request for financial assistance toward a radio outfit may offer them a mighty good investment.

### Commercial Broadcasting in Germany

**I**N SPITE of the troubled condition still existing in Germany, radio is apparently slowly progressing along the paths it has already followed in this country. Germany has, in the past, been in the forefront of radio development; her engineers and artisans have turned out some wonderful radio equipment. The Goldschmidt alternator is a marvel from the standpoints of both design and construction, and the Telefunken marine sets were probably as efficient as any ever put into ship service.

Had the war not occurred, broadcasting by radio telephone would probably have progressed technically in Germany as far as it has here, and certainly it would have been better controlled and regulated by the Government. It is difficult to imagine how government action, anywhere, could have resulted in a condition worse than that at present existing here. A private company (Eildienst Gesellschaft) has started the commercial exploitation of radio broadcasting by renting receiving equipment to subscribers, who pay 500,000 marks annually for the service and use of the sets. The present subscribers are mostly banks and business houses, and the news broadcasted twice daily contains principally financial notes from foreign lands. An agency in New York transmits stock quotations, and other commercial matters to the high-power station at Nauen, near Berlin. The material is then broadcasted over Germany from a government station which this private company leases for the required time. It is anticipated that the material despatched by the American agents will be received by the broadcast licensees within ten minutes of the time it is sent from New York.

We wonder just what the company anticipates doing to the firms who 'make their own' and so are able to receive the broadcast service without paying the subscriber's fee.

### A New Station for Sweden

**A**N ANNOUNCEMENT from the Department of Commerce gives the particulars about the new station to be erected by the Swedish Government at Goteburg, the port at which cables enter Sweden. The contract, which was obtained by an American company in competition with British, French, and German bidders, will furnish for the station a 200-KW Alexanderson alternator. The steel antenna towers will be similar to those of the radio Corporation station at Rocky Point, with which station the Swedish station is expected to communicate directly. Most of the apparatus will be built in America, but the towers will be designed and built in Sweden.

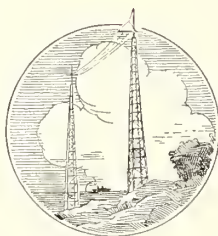

It is expected that the station will be completed before the end of the year, and that a large transoceanic traffic will be built up with this new connection. At present, Sweden has to rely on other countries for making its foreign connections and too frequently this has proved commercially disadvantageous.

One special service which it is anticipated will be inaugurated through this new station is free medical advice to ships at sea, the advice to come from the best hospital staffs in Sweden.

As Sweden is essentially a maritime nation with thousands of seamen on the fishing banks within radio reach of their home ports, this service will probably prove of such worth as to strengthen further the Government's determination to maintain her communication system well abreast of modern developments, a work in which the Government has been actively engaged during the last three years.

### Increased Speed of Radio Traffic

**S**EVERAL times there has been announced through the press the accomplishment of high-speed radio communication, but in general these spectacular results have been maintained for a short time only, when the conditions were especially favorable. A recent communication from the Radio Corporation shows that the development of the automatic transmitter and high-speed receiver required for communication at rates in excess of thirty words a minute is steadily progressing.

The report states: "On the last voyage of the





#### U. S. FOREST SERVICE BOATS IN ALASKAN WATERS

The *Wanigan*, floating home of the men who patrol the Tongass National Forest, keeps in communication by radio with its motor boats. The latter serve as tenders, towing the houseboat from place to place along the shore line, bringing supplies and performing various duties necessary to the protection of the territory. The *Tamm*, shown at the left, is the headquarters boat, which has survived many storms and by the use of radio has helped to save both life and property

White Star liner *Majestic*, the world's greatest steamship, radio messages were exchanged with shore stations of the Radio Corporation of America at speeds of more than eighty words a minute when the vessel was one thousand miles at sea. Ordinarily, speeds in excess of about twenty-five words a minute cannot be attained by hand sending, and in order to meet the demands of increasing radiogram traffic created by the large passenger liners, machine sending must be used, in which case a given message can be sent and received in one third the time required by manual methods.

"The earlier experiments aboard the *Majestic* permitted only one-way high-speed transmission, namely from ship to shore, there being

no apparatus on board the vessel capable of receiving high-speed transmission. In order to effect two-way high-speed telegraphic service on the vessel during the last voyage to New York it was equipped by the Marconi Company with a high-speed receiver which worked most satisfactorily. High-speed signals were also received from Paris at a distance of eight hundred miles at eighty words per minute. Wireless press was completely and perfectly recorded by the automatic receiver through medium static. The principal benefits will be derived from the new apparatus when it is installed on all vessels of the larger type which handle great volumes of traffic."

J. H. M.



# Radio in Summer Camps

By ELON JESSUP

Whether you are a father, mother, or young son or daughter, you will enjoy this interesting article about the increasing use of radio in boys' and girls' camps.

Possibly you have heard of Lloyd Espenshied, the radio engineer who was instrumental in bringing about the first communication by radio telephony between Washington and Paris, and Washington and Honolulu; or you may have operated one of the receivers designed by H. R. Langley of the General Electric Company; but it is unlikely that you know that both these men first became interested in radio at a certain summer camp up on Lake Champlain.

If camp life holds any appeal for you, you should not fail to read Mr. Jessup's description of what radio is doing for young Americans out-of-doors.—THE EDITOR.

**L**AST summer, more than 500,000 American boys and girls, ranging in age from six to eighteen, were members of summer camps. Considering that a few years ago, within the memory of all of us, the institution of summer camps for

young people was almost unknown, this is a pretty fair indication of how firmly the idea has taken hold.

The exceptional educational and recreational opportunities for young America which these camps represent is too well known to require



IN THE "SHACK" AT CAMP DUDLEY

This camp has been using radio since 1908! Every summer, a club, consisting of enthusiastic experimenters, operators, and others interested in radio, holds weekly meetings and engages in all such activities as regular transmission and reception, construction of apparatus, and code and theory classes





CALIFORNIA SCOUTS WITH THEIR 3-TUBE RECEIVER AND SPARK-COIL TRANSMITTER

Bulky apparatus can be carried to the camping place by auto or trek cart, but an evident improvement for a portable station would be the use of dry-cell tubes, making the heavy storage battery unnecessary. These Scouts use a strip of wire mesh, which they place in the water or bury in damp earth, for their ground connection

much comment. As one camp director has expressed it, you find in the well-run camp "healthful recreation, wholesome companionship and educational advantages combined in a program of activities that is in keeping with the progressive tendencies of the day."

To the person interested keenly in radio, the phrase "progressive tendencies of the day" may perhaps give rise to curiosity as to just what is being done with radio in these numerous camps. For here, unquestionably, is an activity having at once recreational and educational value. Logically, it would seem to have a very real place in the average camp program.

The answer in a general way is as follows: in Boy Scout camps, the use of radio and the interest in it are practically universal, and have been for some time; a Boy Scout troop not having a radio outfit is a rare exception. Furthermore, this may be applicable even to winter camps, as indicated by six hundred Boy Scouts who last winter spent their holidays camping in the Interstate Park of New York and New Jersey. Radio sets were almost as thick as snowshoes and skis.

As for the camps which are not connected

with the Boy Scout movement—"private camps" as they are commonly called—it may be stated, broadly, that two summers ago there was no interest in radio to speak of, last summer there was a smattering of interest and during the coming season there promises to be a great deal of interest.

Last summer I visited several of these camps, some of which were for boys, others for girls, and more recently I have talked with numerous camp directors whose camps I had not seen. I wanted to know whether radio was included in their programs of camp activities, and if not I was curious to learn the reasons for its absence. Various attitudes which I met were about as follows:

Some directors showed an entire lack of knowledge and interest in radio and expressed distaste at the suggestion of its being used in their camps. Other directors expressed interest in radio and wanted to know more about it. A few directors freely acknowledged that radio had proved a valuable addition to their camp activities.

As regards the first of these three attitudes: there are some camp directors who frankly object to having a radio set on their premises.



THE SET IN OPERATION

A good aerial can be strung up almost anywhere, in the country, and even a very small portable transmitter will send out its signals with a practical range of a mile or so. The single-tube transmitter is undoubtedly what Scouts and campers are going to use more and more. With careful planning, all apparatus for both transmitting and receiving, except the batteries, might be placed within a box the size of either of the receiving cabinets shown in the picture.

Their reason for feeling this way about it is that they wish completely to divorce camp life from any suggestion of city life. A radio set they classify more or less with automobiles and the movies; something of a distracting influence. During the two or three months while the boys or girls are in camp, these directors feel that they should be living in as complete isolation as possible from the outside world.

I report this attitude, without comment, as I found it. Those who hold it, are, I believe in the minority.

The majority of camp directors are in the second classification which I have given; theirs is the "we'd like to know about it" stage. And this stage in turn is perhaps evenly divided between those who have not had any radio sets in their camps so far but contemplate putting them in, and, on the other hand, those who have experimented slightly with radio and would like to go further with it.

Many camps have "played" with the idea of radio but with the exception of the Boy Scout camps, there are very few so far that have gone at the subject in a really business-like way. As I have indicated, however, there is a growing

interest in radio both from the standpoint of education and entertainment.

As regards girls' camps, radio is regarded almost exclusively as a means of entertainment, for girls are not generally considered to have a mechanical turn of mind; yet, as indicative of the fact that this commonly accepted theory does not always hold true, I might mention that some time ago the Young Women's Christian Association gave a course in radio construction. During the coming season, the Y. W. C. A. intends to install several radio sets in its summer camps.

Boys, of course, are more technically minded than are girls. And almost all boys like to hear the baseball scores and listen to an occasional concert. The wise camp director realizes full well that when a boy is genuinely interested in a given subject, he should by all means be given every facility for expressing this interest.

That is one reason why directors, of boys' camps especially, are turning more and more to radio. The boys themselves have to some extent created the demand. A boy brings to camp a set that he has made at home and a goodly proportion of the rest of the crowd immediately wants to make a set like it. Con-



sequently, in a number of camps, the construction of radio sets has become a recognized camp activity.

For example, I have in mind one camp in which boys last summer spent one hour each day on the construction of crystal sets, each of which, after the camp was over, was carried proudly home. Only a comparatively small proportion of the boys were engaged in this activity.

Yet, as I have indicated, camp directors as a whole are in something of a quandary about radio both as regards entertainment and instruction. It is a new subject to them and they are not yet "sold" on radio. No doubt there are several exceptions to this rule and I will tell you about the one notable exception with which I am familiar. I am now speaking of a boys' camp which is in no way related to the Boy Scout movement—Camp Dudley on Lake Champlain, a camp of about two hundred boys ranging in age from twelve to sixteen.

Two significant facts are attached to this camp, one of these being that it is the oldest organized boys' camp in America and the other is that wireless work has been one of its activities for more than fifteen years. Thus,

one has here an exceptional opportunity to view methods and results.

First, as regards tangible results. The boys who in the past spent their summers at Camp Dudley have grown up and gone out into the world. Some of these boys when in camp had no idea about the sort of work they intended to go into; others did. Take for example, R. H. Langley, now in charge of the receiving section of the radio engineering department of the General Electric Company. His first interest in wireless was aroused when he was a boy in Dudley. The same is true of Lloyd Espenschied, the engineer who was instrumental in bringing about the first wireless communication between the Pacific Coast and the Philippine Islands.

Radio, in its present-day phase, so far as Camp Dudley is concerned, dates back three years. Then it was that a club was formed among the boys, who forthwith became gleeful over obtaining permission from their "Chief," H. C. Beckman, to build a "shack" in which to house the instruments and serve as a clubhouse. Carpentry is one of the camp activities, so they knew how to build a real house and they made a good job of it.



LOCAL RECEPTION ON A LARGE LOOP ANTENNA

First Class Scout Malmros of Troop 1, Roslyn, Long Island, tuning in signals from his headquarters radio telegraph station





THE WIRELESS TOWERS AND RECREATION BUILDING AT CAMP WALLKILL, NEAR LAKE MOHAWK, N. Y.

Membership in this club became in the boys' eyes a desirable goal. Not every boy was permitted to join it. You had, first of all, to know quite a bit about the principles of wireless. Two years ago the membership was somewhat limited but last year about half the boys in camp belonged to the club.

There are, no doubt, many people who would like to know how this radio club functions. The following details were related to me by Martin Walter, Jr., who has been actively engaged in wireless work at Dudley for a number of years, first as a boy in camp and later as an assistant to the director. It is commonly the custom at Dudley for many of the boys to come back to camp season after season, and then when they reach college age some of them become assistants to the director. Mr. Walter says:

"Our radio club at camp is governed by what we call the 'radio committee'. This consists of about six of us who have been interested in wireless work for several years. We all have government licenses and consequently know the code well enough to receive press dispatches every evening. Last summer, however, this was not necessary, as the broadcasting stations

furnished most of the matter we were interested in. This was mainly baseball scores, and the weather for our section, correct time, and even stock reports which some of the older fellows were interested in. As soon as the news was received it was neatly typed and posted on the 'radio bulletin' which occupied a prominent place on the wall of our dining hall. Music was also received every evening and this brought quite a crowd of listeners to the 'shack.'

"We had a small transmitting set and under favorable conditions we could talk with fellows in New York City. However, we had a regular daylight schedule arranged with an amateur in Albany (about 150 miles) and another with the University of Vermont, Burlington (about 50 miles). By relaying to these stations, messages were sent home by the fellows. One of the committee was supposed to be in the shack all the time, and he was responsible for the apparatus. Any one could come in and work the receiving set, provided the consent of the man in charge was obtained, but only fellows holding transmitting licenses were permitted to use the sending set.

"The men on the committee were not



allowed to serve as officers of the club but assumed a position something similar to a board of directors. Elections were held by ballot for the officers. We had no dues, as the camp supplied everything. The regular meetings of the club were held on Sunday afternoons. All boys in camp were welcome to attend and a good many became interested in this way.

"After the roll call, one of the committee generally gave a talk on constructing sets—how they worked—and simple theory. We were lucky last summer in having at camp a Navy operator and he gave talks on his experiences which were always very interesting and well received. Occasionally, a visitor came up who had had some experiences and he was never allowed to get away without giving a talk.

"After the meeting was over, the committee was always on hand to answer any questions, and you may be sure there were enough to keep

us busy. We also had code classes twice a week. These did not work out quite so well, probably because the fellows were too young to be interested in that end of it. After a whole summer of practising, a few fellows got enough speed to take the license exam. when they got back, and the rest of them knew, at least, that there was a code.

"For the first time, last year, we started making sets. This took very well and several sets were finished at camp and a number more were in the 'all but' stage. This idea was started late in the season, or more would have been constructed. We drew up plans for a standard set costing about twenty dollars and any one wanting to make it had to have his parents' consent. After determining the number, a bulk order was sent to a firm in New York and in this way a discount was obtained. After the parts arrived the sets were made in the shop and tried out in connection with the regular camp set."

#### 72% OF THE 1922 CAMP WALLKILL BOYS CONSTRUCTED SETS

The radio workshop where boys are given instruction in building their own apparatus. Five of last summer's campers passed the government requirements and obtained operating licenses, through the training they received at camp



# Operating a Loud Speaker on One Tube, Without Batteries

By WALTER VAN B. ROBERTS

Princeton University

THOSE who are fortunate enough (from the present point of view) to have 110 volts *direct current* available at every lamp socket will find the receiver described below to have the

following advantages:

1. It uses no batteries of any kind, thus eliminating all battery cost and upkeep.

2. It makes use of a loop aerial, which saves the trouble of stringing an aerial and allows the receiver to be set up at any place in the house where a lamp socket is handy.

3. The output is great enough so that local stations (say up to 25 miles) can be heard satisfactorily over a good-sized room.

4. In operating, only two adjustments are really necessary, and neither of these is difficult to make.

5. The cost of the parts is small, compared to the cost of parts that would be required to get the same volume out of the loud speaker by any other means using a loop aerial.

6. Only one vacuum tube is required.

There are disadvantages also:

1. The set cannot be relied upon for satisfactory loud-speaker results from distant stations, although on some nights distant stations can be heard surprisingly well.

2. The quality is not so good as that obtainable by other means. There is the very high weak whistle of the interruption frequency of the super-regenerative circuit, and if the signal is very weak a certain amount of hissing noise develops in the circuit itself. However,

if the signal is fairly strong, the quality is good enough for all practical purposes.

3. It is not very selective. This is one reason why distant stations are hard to get. However, there is no difficulty in separating the 360-

from the 400-meter stations, even if the one to be excluded is only a few miles away.

On the whole, it is probably the most practical arrangement at present available for those who want loud-speaker results with no upkeep cost or bother with battery charging, who are satisfied with the programs of local stations, and who have the necessary direct current supply.

On page 110 is shown the circuit, which is seen to be the one made public by Arm-

strong except for the rearrangements which are necessary in order to avoid using batteries, and the addition of the fixed .0005 mfd. condenser which seems to make the circuit easier to operate. The 2 mfd. condenser and the high-tension winding of the Ford spark coil are not necessary—they were put in to keep the direct current out of the loud speaker windings and thus avoid all chance of overheating them.

The filament current is limited to the desired value by making a proper combination of ordinary electric lights connected in parallel. A single 100-watt light will probably pass enough current for the filament of a 216-A tube. A 100-watt light with a 25- or even a 15-watt light in parallel will be enough for a VT-2 tube. A single 25-watt lamp is as much as can be used with a Radiotron UV-201-A or a Cunningham

Mr. Roberts, who is engaged in research work at the Palmer Physical Laboratory, Princeton, N. J., has been experimenting for some months with various systems of reception employing a single tube. His article, "A Single-Tube Loop Set in a Brief-Case," which was published in RADIO BROADCAST last month, describes a receiver weighing only six pounds, including everything. Although Mr. Roberts' claims for this portable set are very conservative, many readers have apparently become so enthusiastic that they are building, or planning to build, similar outfits for use this summer.

The batteryless loop outfit described this month will undoubtedly make a similar appeal to those who have long been wanting a loud-speaker set which could be operated on a loop without necessitating a prohibitive outlay of capital.—THE EDITOR.





MR. ROBERTS' BATTERYLESS LOOP SET

The filament and plate currents are supplied from the ordinary D. C. house lighting circuit. 1 and 2, 75-turn multilayer coils; 3, Western Electric VT-2 tube; 4, 4-6 ohm rheostat; 5, .05 mfd. telephone shunt condenser; 6, 1250-turn multilayer coil, shunted by a .001 mfd. condenser (7); 8, 100-watt electric lamp; 9, 25-watt lamp; 10, .0005 mfd. variable condenser; 11, switch for turning on and off the 110-volt supply; 12, .002 mfd. condenser across the 1500-turn multilayer coil (14); 13, lamp socket which feeds the 110-volt current into the set; 15, .0005 mfd. condenser, connected directly across the interruption frequency circuit; 16, 2 mfd. condenser in series with the loud speaker; 17, Ford spark-coil, the secondary of which is used as a choke coil

C-301-A. It is not a bad idea to use a carbon filament lamp for the 100-watt lamp because carbon has a high resistance when cold and so gives the effect of turning the current on slowly. The variable resistance is an ordinary filament rheostat and is used to get a negative potential for the grid. It has very little effect upon the filament current.

#### ABOUT THE LOUD-SPEAKER

WESTERN Electric VT-2 tubes (also called "E" tubes) have proven very satisfactory. The Western Electric 216-A, used in that company's power amplifier should be equally good. A Radiotron 201-A or Cunningham C-301-A tube will work well with head phones

but will probably not give enough volume for the loud speaker. If the Western Electric 10-D loud speaker is used with the above mentioned W. E. tubes, the transformer in the base should be disconnected, which makes it equivalent to the 518-W loud speaker, which is the type supplied with the power amplifier.

For any one who likes to build apparatus and knows anything about radio, the foregoing remarks are sufficient. He can wind spider-web coils to avoid buying the small multi-layer coils and he can improvise his own means of varying the mutual inductance between both sets of coils. The writer prefers to spread all the parts out on a flat board where it is all in sight (though rather unsightly!) and to vary mutual

inductances by the simple process of sliding the coils around by hand.

For the benefit of any one wanting to try out this circuit without bothering to make up any parts or figuring out his own way of mounting them, the following instructions are given. It is assumed that the conventional arrangement on the back and front of a panel is desired. The constants of the circuit are the same as used by the writer for the past six months. They are satisfactory; but probably not the best: for instance, the Ford coil arrangement could be replaced with advantage by a properly designed step-down transformer.

A list of parts to be bought is as follows:

- One tube
- One socket
- One filament rheostat, 4 or 6 ohms
- Four sockets for ordinary electric lights
- One Ford spark coil or any other audio-frequency choke coil
- One fixed condenser, capacity 2 microfarads
- One fixed condenser, capacity .05 mfd (a Federal costs \$.50)
- Three fixed condensers such as Micadons, of capacities .0005, .001 and .002 mfd
- One Dubilier variable condenser, .0005 or .001 mfd. maximum.
- Two multilayer coils of 75 turns each
- One multilayer coil of 1250 turns
- One multilayer coil of 1500 turns
- Two double-coil mountings for these coils
- One loud speaker
- One loop aerial of about twice as many turns of wire as usually used on radio-frequency amplifier sets.
- One panel of any insulating material, 7" by 16" or more
- One cabinet, or brackets to support panel

Supply of binding posts, Fahnestock clips, screws, wire, etc.

CONSTRUCTION DATA

ON THE front of the panel (allowing a little space around the edges if it is to go in a cabinet) mount:

In the centre, along the upper edge, three electric light sockets sufficiently spaced so that a 100-watt light will go in alongside another light.

In the centre, at the bottom, the variable condenser, the whole thing being mounted on the front of the panel as this Dubilier "Variadon" is very thin.

At the bottom, to the left of the condenser, the knob of the rheostat, which is preferably behind the panel. The rheostat may be turned into the "off" position in lieu of a switch when not using the set.

At the bottom, to the right of the condenser, an electric light socket into which the plug carrying the 110-volt supply will be screwed when operating the set.

In the upper left and upper right hand corners, the two double-coil mountings, each being mounted so that the movable coil swings sideways away from the centre of the panel.

On the left edge, near the bottom, two binding posts or clips for the loop.

On the right edge, near the bottom, two posts or clips for the loud speaker or phones.

Behind the panel, mount:

The vacuum tube socket, just above the rheostat, being careful that the position is such that the filament won't sag toward the grid.

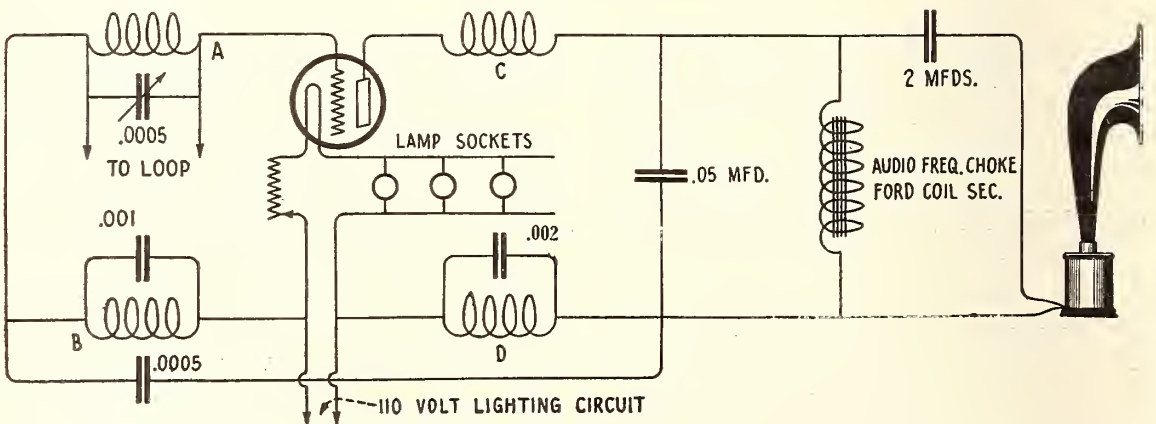

THE CIRCUIT ARRANGEMENT FOR THE ONE-TUBE LOUD SPEAKER LOOP RECEIVER

A and C are 75-turn multilayer coils; B is a 1250-turn coil and D a 1500-turn coil



Behind the right hand side of the panel, the Ford coil, the 2 mfd, and .05 mfd. condensers, in any convenient arrangement.

The small Micadons can be supported in mid-air by the wiring if it is stiff, or if any experimentation with different values is desired, they can be sprung between two Fahnestock clips whose flexible parts are flattened out and bent to stand out perpendicularly from the panel.

#### HOW TO MAKE IT "COOK"

THE wiring can be readily done by following the diagram, but even if this is done without error, there is only one chance in four that the set will work—at the first try. If it doesn't, swing both movable coils out as far as they will go, set the condenser at maximum, and touch both leads to the loop. If no click or very faint high whistle is heard, the 110-volt circuit is connected the wrong way around. This is easily remedied by reversing the points of the plug. Next, set the condenser at about half its maximum value and slowly move the tickler coil in. If a hissing noise is

not heard, the tickler coil is connected backward and the connections to it must be interchanged. Finally, when signals have been obtained with the 1500-turn coil swung way out, see if any improvement can be effected by bringing it in slightly. If not, reverse the connections to this coil also and thus find out which way it works best. (It is assumed that the tickler coil and the 1500-turn coil are the ones that have been mounted on the movable parts of the two-coil mountings.)

In operating this receiver, it may happen that when the tickler coil is brought in too close, the circuit will suddenly go dead. In that case, swing the tickler away a little and touch one of the leads to the loop. A very little practice will make any one familiar with the tuning of the set.

In concluding, the writer wishes to repeat that he is only giving values of capacities, coils, etc., that have worked, and that a few turns less on the tickler coil or loop, or a rearrangement of the coils and condensers in the interruption circuit, or a different kind of tube, may bring about improved results.

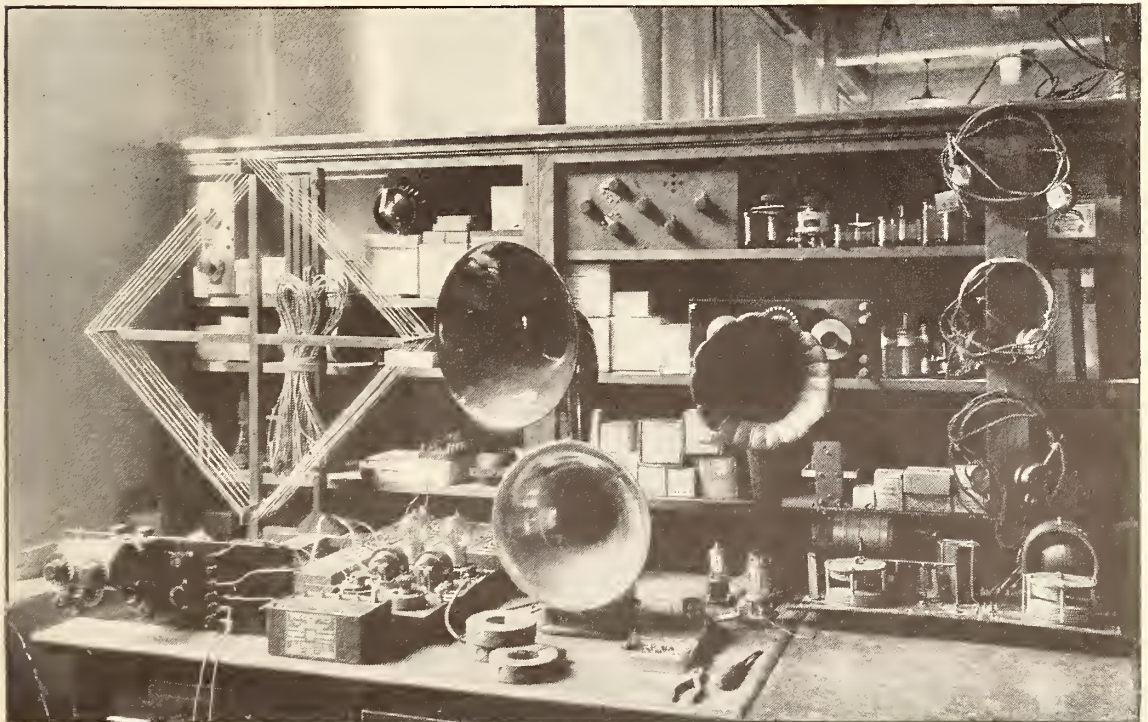

A CORNER OF THE OFFICE OF RADIO BROADCAST, SHOWING APPARATUS TO BE TRIED OUT  
It is our practice to test new circuits and new devices before recommending them to you

# A Stormy P. M. at Alice's

By WILLARD WILSON

I HAD come to call on Alice, and we were taking our tea with animal cookies—that is, she was. I was taking the cookies alone. I have always hated tea, it has such a slimy, greenish taste.

Alice had devoured a great amount of cookies and tea, and I had imbibed a fairly large herd of animals, but still the small tea talk wouldn't come. The atmosphere was getting horribly tense—you know—the way it is when a thunder storm is coming, and the static begins to buzz and whoop in your phones. Already I could see the preliminary flashes of lightning from Alice's eyes, and I began involuntarily to cringe and try to appear humble—and take it from me, that is not a hard job when Alice is about.

I had a pretty good idea of the cause of the oncoming tempest—I hadn't been up to see her or take her anywhere for a whole week. Heaven knows it wasn't my fault! I have a new Armstrong set and I had been mothering it for six days like an old hen, trying to get the blame thing to perk.

But about Alice. She began by gazing thoughtfully at the tips of her little shoes. Carefully she beheaded an elephant, then washed down the carcass with a draught of tea. Eventually she looked at me.

"Willy"—she knows I hate that name above all others—"Willy, where have you been all week?" Her voice was soft and cooing—it always is—but I quailed.

"Oh, I've been pretty busy——"

"Why, Willy!" She interrupted my nonchalant tone with an incredulous cry. "I thought you were having your vacation!"

I began to sweat a little at that, but managed to stave off my fate a little longer by swallowing a cow, a donkey, and two dogs. (It's funny that there are always more dogs in animal cookies than any other beast.) At the end of that operation I had concluded that the quickest way out for me would be to tell the truth.

"Alice dear—" I began bravely. But she cut me off short. The storm had burst and she was in the first stage, where they get defiant.

"Don't 'dear' me!"—she said savagely. "If you don't come enough to come around once in a while——"

Here I interrupted her. "Now, Alice, please don't raise a row until you know what it's about." I was resolved to have at least a hearing, though I was perfectly aware that it would make not the slightest difference to her what it was about.

"I just got a new radio set," I explained carefully. She nodded her head viciously. I really believe she already knew it. But I went on patiently describing the weary hours I had spent tuning and experimenting—I tried to make it all sound very important—and then I began to discuss its merits. I had it going great



I MANAGED TO STAVE OFF MY FATE A LITTLE LONGER BY SWALLOWING A COW, A DONKEY, AND TWO DOGS



just the night before, so I guess maybe I did get a little over-enthusiastic.

"Why," I told her proudly, "Some day I expect to be able to hear program broadcasted from clear across the continent, then across the ocean, and then—" I became aware that she was not sharing my jubilation. Indeed, I saw that she was almost ready for the next stage. Her lip was beginning to tremble. That scared me. I haven't lived this long without learning some of the signs, and I simply cannot be brave in the face of hysterics. It makes me feel like a murderer or something. I never can tell what I'll do when a girl begins to cry.

"Now, now," I said, soothingly, panic tugging at my heart. Nervously I patted her hair. She has wonderful hair—so soft—and with a fresh, sweet smell like new-mown hay. Yes, it's bobbed. I don't know whether that is what makes the new-mown smell or not. But she wasn't quite ready to be soothed yet.

"B—Bill," she went on in that brave, plucky way she has—as if it is breaking her heart and yet she must finish what she has started—"after we are married, and getting o—old"—she moaned dismally—"will you spend all of your time listening to some old pup-pup-program?" She gulped convulsively and looked up at me.

Before I could answer, she presented her conclusive argument. She (speaking vaporically) switched her condenser. It is wonderful the amount of moisture and weeping that can come from two big, pleading eyes. I knew it would get me—it always does. In a moment all I could think of was how I could stop her crying. Frantically I racked my fevered brain for some new scheme, but before I had decided on any definite plan of action she was going again.

"B—Bill," she sobbed, "w-will you promise never to neglect m-me again for that—that old radio?"

"Yes! Yes!"—I promised wildly, distracted by her suffering, "I'll never look at a B battery again. I'll throw my phones out of the window. I'll smash up my—" She put her arm around my neck and cuddled down in my arms. I stopped my resolutions with a sigh of relief. I knew that the storm was over,



WOMEN ARE SO BLAMED INCONSISTENT

and somehow felt that I had gone a bit too far on the swearing off as it was.

A few moments later she lifted her rumpled head from my arms. "Billy dear," she said softly, "did you say it was an Armstrong set?"

"Yes," I answered, "an Armstrong Super."

"Is it made by the same company that makes Armstrong baking soda?"—she wanted to know.

I had never heard the names of the different kinds of baking soda—in fact I never even worked as a cook—and that question stumped me. I slowly swallowed a horse and a camel, then, like a true Californian, began to talk of the weather.

Alice didn't insist on an answer and in about three minutes she was as cool and sweet as a marshmallow sundae. She poured herself another cup of tea as if nothing in the world had happened—just after we had finished a scrap that could easily have turned our lives into different channels.

That's the dickens of it. Women are so blamed inconsistent! Alice was up at our house last night, and she wouldn't even take the receivers from her ears long enough for me to cut in on Arlington for the time signals.

# Learning the Code

Why All New Recruits to the Radio Game Will Find It Worth While to Learn the Radio Telegraph Code. How to Memorize the Alphabet, and How to Train Your Ear. Tips on Copying Code. The Use and Abuse of the Sending Key

By WILLIAM HARRIS, JR.

**Y**OU are one of these out-and-out enthusiasts, let us say, who falls under the general head of broadcast listener. Whether you are the kind of B. C. L. who will sit for hours enjoying the local programs, or (the other extreme) the kind who no sooner bags one brace of station calls than he is off on a hunt for more elusive game, is immaterial: you have a set and you think radio is great stuff and you want the ether waves to talk to you.

No doubt you have noticed that there are other stations in the air besides those that do the broadcasting. If you tune down below the concert range to 200 meters, you will be regaled with all sorts of interesting and unintelligible sounds, ranging in character from the growl

of a bulldog to the whistle of a peanut-roaster. These sounds would, of course, be far more interesting if they *were* intelligible—to *you*. You might listen to an amateur in Florida chewing the rag with a comrade up in Michigan whom he has known on the air for five or six years but has never seen. You might hear two fellows in neighboring towns come back and forth at each other almost as quickly as they could use the telephone, discussing some new hook-up, telling stories, or speculating as to the duration and intensity of the heat wave that's passing through the town where one station is located on its way toward the other, or aiding in the relay of a message from the Atlantic coast to the Pacific.

Then go up to 600 meters, if your broadcast

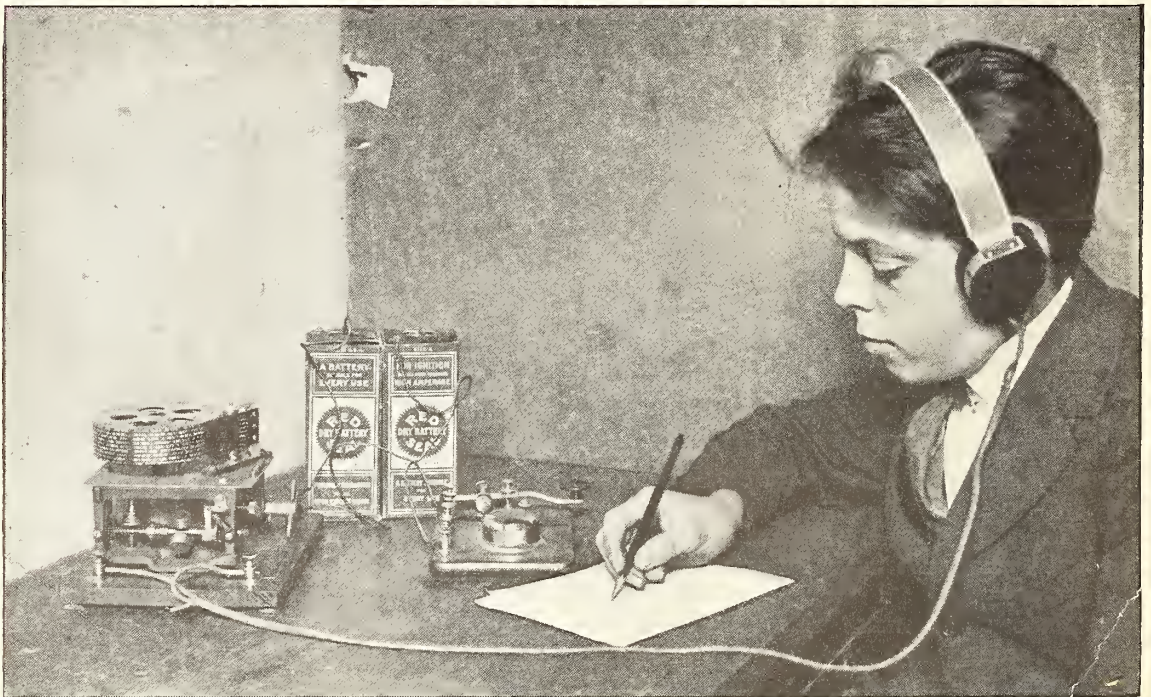

AN AUTOMATIC SENDER IS A GREAT HELP TO THE WOULD-BE TELEGRAPHER

He can turn it on at any time and receive code messages at any speed. This boy uses either the hand-key or the machine to operate the small buzzer shown on the key baseboard. By comparing his own sending with the smooth, perfect sending of the machine, he is able to improve his own "fist" very quickly



receiver will tune that high, and listen to the whines or the musical notes of the ship stations. If you could read code even at the rate of twelve words a minute, you might learn that that booming spark signal is advising the owners of S. S. *So-and-so* that their vessel is delayed six hours on account of heavy fogs but will reach port in the morning. Or the musical note may carry a radiogram from a passenger returning from Europe to his family: "Back to God's country to-morrow tell Mary to make one of her old-fashioned rice puddings love, Ed." You'd be surprised what choice bits a businesslike flock of radio code signals sometimes carries!

The amateur and ship traffic is not all that is of interest, by any means. Of course, your broadcast set will not take you up into the realm of the transatlantic stations—the high-power fellows that come in on a long-wave receiver clear and loud with a single tube. Your 360 to 400-meter outfit won't even go up near NAA's (Arlington's) transmission of time signals (12 noon and 10 P. M.), weather forecasts and news from all over the world. But once you have learned the code, you will probably want to buy, or assemble, yourself, a receiver for the longer waves.

Nor is listening-in on the world the only reason why it will be worth your while to learn the code. Thousands of amateurs will testify that the best sport of all is carrying on two-way conversations with other "hams."\* You may not care to undertake anything as pretentious as the installation of a station with a 500-mile transmitting range; but with a single tube and a simple home-built set you can call up a

### How to Get Your Transmitting Licenses

If you wish to transmit, you must have two licenses, one certifying you as an operator, the other for your station. You must be able to receive at least ten words a minute (five letters or characters to the word), and must comply with certain other requirements explained in the Government pamphlet: "Radio Communication Laws of the United States." It is advisable to obtain this pamphlet, as it gives a list of places where examinations are held and other information either necessary or helpful to the prospective operator. It may be had from the Superintendent of Documents, Government Printing Office, Washington, D. C. Price, 15 cents a copy.

friend who has a similar outfit down the other end of the street, or over in the next town.

But enough of this. If you are still unconvinced that learning the code will open a great new field of interest and enjoyment to you, just ask some dyed-in-the-wool amateur whether he's glad *he* learned it.

#### HOW TO ACQUIRE THE CODE

**B**EFORE attempting to do any receiving at all, you should memorize the code equivalents for *every one* of the twenty-six letters of the alphabet—memorize them so that you can lay the edge of a card over the code symbols on page 116, leaving the letters showing, and repeat to yourself correctly each letter, checking up each time by looking at the correct code equivalent. Take a few letters first—for example, A through F—and "get these down cold." It is easy to improvise simple ways of associating, in your mind, each combination of dots and dashes with

its letter, ways which will last you until the code is ringing in your head, until **—•••** means B immediately, not "dash, three dots." Leave these six letters and take the letters from G through M. Then review what you have memorized so far and you will have learned thirteen letters—half the alphabet! If you are exceptionally keen, and buckle right down to the job, half an hour's study will give you all the letters; and even if you are only an ordinary mortal, like the rest of us, you should not need more than, say, three or four periods of study of a half hour each.

When you have no one to help you, here is an excellent way of drilling the code into your memory: cover over the code symbols in the list and ask yourself what A is, what B is, etc. Each time you don't know, write the letter you missed on a slip and turn it face down: if you can't think what F is, for instance, put an F slip aside. (It might be well also to put aside one whole alphabet.) Then draw your slips,

\*Those who are interested in building their own transmitting sets will be interested in the series of articles by Zeh Bouck, "Simple Bulb Transmitters," which appeared in RADIO BROADCAST from November, 1922 to March, 1923, inclusive. For a low-power, inexpensive and ingenious arrangement, see "Transmitting and Receiving with the Same One-Tube Set" by Frederic W. Proctor in the May, 1923, number.

# INTERNATIONAL MORSE CODE AND CONVENTIONAL SIGNALS

A	. _ _
B	_ . . . .
C	_ . _ . .
D	_ . . .
E	. . . . .
F	. . _ . .
G	_ . _ . .
H	. . . . .
I	. . . . .
J	. _ . _ . .
K	_ . . . .
L	. _ . . .
M	_ . _ . .
N	_ . . . .
O	_ . _ . .
P	. _ . . .
Q	_ . _ . .
R	. _ . . .
S	. . . . .
T	_ . . . .
U	. . . . .
V	. . . . .
W	. _ . . .
X	_ . . . .
Y	_ . . . .
Z	_ . . . .
<hr/>	
Ä (German)	. _ . . .
Å or Å (Spanish-Scandinavian)	. _ . . .
CH (German-Spanish)	. _ . . .
<hr/>	
Ê (French)	. . . . .
Ñ (Spanish)	. _ . . .
Ö (German)	. _ . . .
Û (German)	. . . . .
<hr/>	
1	_ . . . .
2	. . . . .
3	. . . . .
4	. . . . .
5	. . . . .
6	. . . . .
7	. . . . .
8	. . . . .
9	. . . . .
0	. . . . .

Period	. . . . .
Comma	. _ . . .
Interrogation	. _ . . .
Exclamation point	. _ . . .
Bar indicating fraction	. _ . . .
Parenthesis	. _ . . .
Distress call	. _ . . .
Attention call to precede every transmission	. _ . . .
General inquiry call, (C Q)	. _ . . .
From (de)	. _ . . .
Invitation to transmit (go ahead) (K)	. _ . . .
Question (please repeat after interrupting long messages)	. _ . . .
Wait (A S)	. _ . . .
Break (Bk.) (double dash)	. _ . . .
Understand	. _ . . .
Error	. _ . . .
Received (O. K.)	. _ . . .
Position report (to precede all position messages) (T R)	. _ . . .
End of each message (cross)	. _ . . .
Transmission finished (end of work) (conclusion of correspondence)	. _ . . .

1. A dash is equal to three dots.
2. The space between parts of the same letter is equal to one dot.
3. The space between two letters is equal to three dots.
4. The space between two words is equal to five dots.

one by one. If you know them all, well and good; if not, learn the letters you missed, then and there, and put those slips aside to form a new pile. By this process of running over and over the letters you don't know, you will arrive at about half a dozen—J, Q, X, and Z will probably be among them—which will

represent your temporary Waterloos. Go at these few, and *get them*—till you know them as well as you know A and E. Following this, review the whole alphabet once or twice and call it a day. But keep the slips for the next set-to. They may seem like a reversion to kindergarten days; but they can help you



a great deal. The principal advantage this system has over any hit-or-miss method is that you learn the so-called "difficult" letters thoroughly. Later on, when you hear

—•••— or —•—•— you won't mentally curl up and die, as so many beginners do, missing the next four or five letters before you determine that the —•••— was a P and the —•—•— a Q. For some reason, F and L are

regularly confused by those who are learning the code. Take these two aside and have it out with them: they will never bother you again.

We shall suppose that you know, now, what the code sound for each letter is—when you stop to think. (Call them "dits" and "dahs," not dots and dashes; it helps considerably to give your ear the distinction between the short and long code units). If you can get someone to send to you with a buzzer outfit, while you sweat away with paper and pencil, you should make very rapid progress. Be sure to make him send *always a little faster than you can take*. If he sends too slowly, your attention will wander; if too fast, you will not copy enough to keep yourself encouraged. At first, it is advisable to take chiefly five-letter cipher words—xebjr, otnla, etc.—or else ordinary words sent backward. The reason for this is that if you think you know what is coming, you will "anticipate"—either writing down letters before they are sent (and one is often fooled doing this) or by "getting set" in your mind for a certain letter, thus making it harder for yourself to receive correctly a different one.

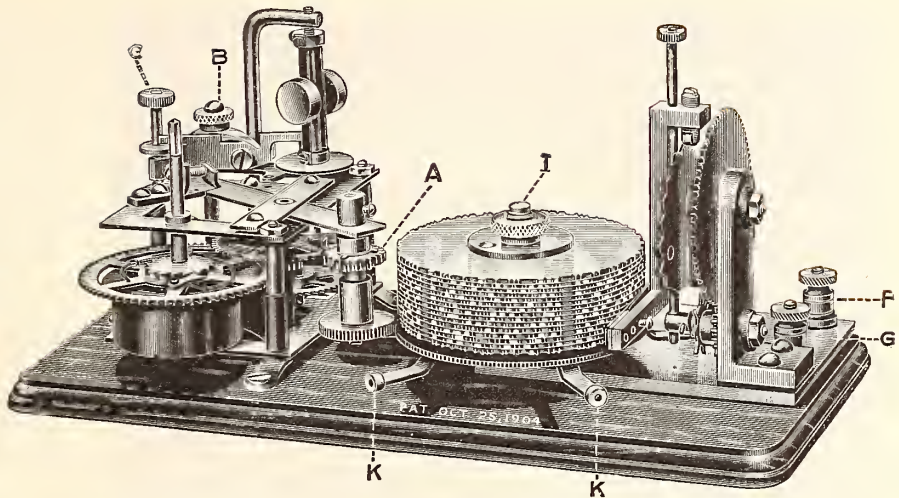

THIS OMNIGRAPH WILL RUN OFF 1200 WORDS ON ONE WINDING  
C regulates the speed—from 5 to 50 words a minute; I is a thumbscrew for changing the dials; K, K, are message changers, which may be operated while the machine is sending

Perhaps it is impossible or difficult for you, in this period of your code development between the alphabet and the copying-slow-press stages, to get someone to send to you. In this case, you can have recourse to either the omnigraph or the phonograph. The omnigraph is an instrument actuated by a coiled steel spring, which, when connected in circuit with an ordinary buzzer and dry cell, makes and breaks contacts according to the raised dots and dashes on its one or more revolving discs. You may think that after a while you would know the omnigraph's repertoire by heart—at least, the words that "make sense"—but it is safe to say that by the time you know the jumbled code letter groups by heart, you will be ready to copy some of the real thing, anyway. Plenty of it is always waiting for you in the ether, ready to have you interpret it when you have the means. A set of six Victor records (12 lessons) can be bought, if desired, which will send all kinds of code to you, at every speed and under various conditions (the more advanced records, for instance, including many realistic bursts

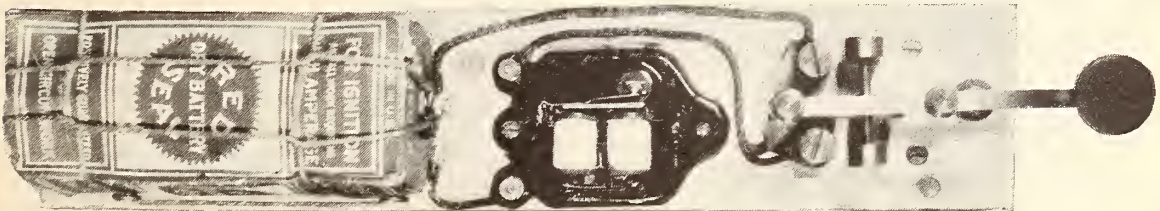

A CONVENIENT WAY TO MOUNT YOUR BUZZER PRACTICE SET



THE PROPER WAY TO HOLD THE KEY

of static and one or more "other stations," to give you practice in copying through interference).

#### A SIMPLE PRACTICE SET

A CONVENIENT way of mounting the three units needed for a practice buzzer outfit is shown at the bottom of page 117. The dry-cell will cost you about 45 cents, the buzzer about 35 cents, and the key anywhere from 0 to several dollars. It will be 0—and just as satisfactory when you are learning the code—if you use simply a strip of springy metal, with a hole in one end, which makes contact with a screw head at the other. A Meccano toy building strip is just the thing. High-frequency buzzers, giving a two-dollar mosquito-like note, may be used if desired, although the 35-cent bark of the ordinary house buzzer is music enough to the ears of most beginners.

A word about sending—but I might as well say "a word" about how to drive a golf ball two

hundred yards. Different operators have different styles, and all of them require a certain amount of practice before being able to send smoothly. Some operators do it all with the wrist, with such a flexibility that the hand "posts in the saddle" like a rider at a trot. Others "fists," no less skillful, roll from side to side when they get warmed up, like a ship at sea. But no good operator lifts his hand off the key while sending, or pecks at the key like a chicken after corn. The most generally accepted method

of holding the key is indicated in the accompanying photograph. Thumb on the side of the key-knob for steadying, first finger on top for applying the downward pressure, and middle finger below, to steady the hand and to give the necessary upward pressure when the key contacts stick (as frequently happens when a heavy current is used). The more you use your wrist in sending, rather than your fingers, the less cramped your hand will be. In this respect, what is true of penmanship is true of telegraphy.

You know the kind of fellow who always drives a car as fast as he can, faster than safety permits; and the kind who always talks loud and long, no matter what other people may have to say. These types are found, alas! in the radio game as well as elsewhere. The first type sends out a jumble of rushed and mutilated signals; and the second jams the air with endless calls, tests, or "bull." Having mentioned these horrible examples, need more be said?

## What Would You Like to Have in Radio Broadcast ?

*The editor would be pleased to hear from readers of the magazine on the following (or other) topics:*

1. *The kind of article, or diagram, or explanation, or improvement you would like to see in*  
RADIO BROADCAST.

2. *What has interested you most, and what least, in the numbers you have read so far.*



# Is Short-wave Relaying a Step Toward National Broadcasting Stations?

Listeners-in in Cleveland, Ohio, Now Hear Pittsburgh as Distinctly as They Hear Local Stations, by a New Method of Broadcasting

By W. W. RODGERS

Westinghouse Electric & Mfg. Co.

Re-broadcasting is a system of transmitting on a certain wavelength, picking up the signals at a remote point, and using the received energy—amplified locally—to actuate other broadcasting transmitters on one or more different wavelengths.

The possibilities of re-broadcasting are indeed staggering. A central station, located in Washington, for example, could carry the voice of the President to listeners in every section of our country if re-broadcasting, as described in this article, were properly fostered. That is a large order, but we shall undoubtedly see its realization by this or some similar system before long. This article by Mr. Rodgers is the first to appear on this very interesting development.—THE EDITOR.

**P**ERHAPS there is no phase of broadcasting that appeals to all of us more than the establishment of national broadcasting stations—just a few of them distributed carefully at selected centres throughout the country so that they serve all sections in a satisfactory manner. One large station, for instance, might serve the public within a radius of 500 miles, and enough of these stations could be established, under government regulation, so that no one within these circles would lack entertainment—or get too much of it on interfering waves.

The present trend in radio seems to indicate that the national broadcasting station will help to solve some of the most important broadcasting problems.

Already, the Westinghouse Electric & Manufacturing Company has successfully relayed concerts on 80 to 100-meter wavelengths with results that warrant further research along this line. Programs from KDKA, the company's broadcasting station at East Pittsburgh, have been relayed from its experimental station, KDPM, in Cleveland, Ohio and from WBZ, in Springfield, Mass. In both these cities, KDKA's concerts have been received with great clarity, even though Cleveland is one of the so-called "dead" spots of the country.

Short-wave relaying and the establishment of national broadcasting stations are, therefore, pertinent subjects in which every radio fan, engineer, and manufacturer should be vitally

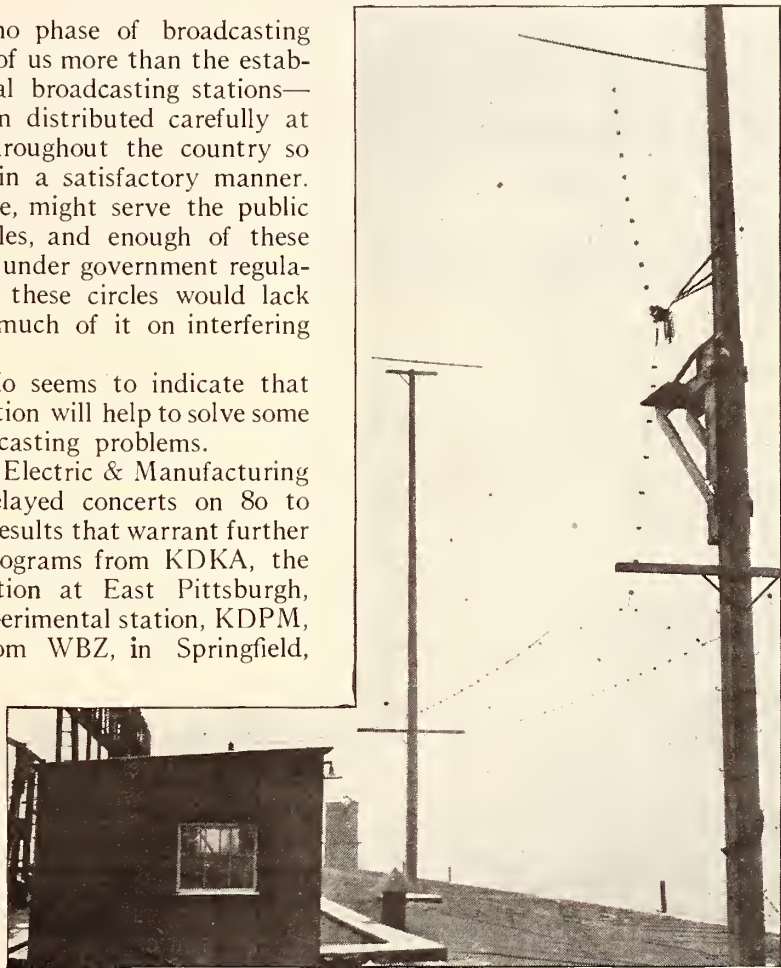

THE SHORT ANTENNA USED FOR 100-METER TRANSMISSION  
Erected at KDKA, East Pittsburgh, Pa.

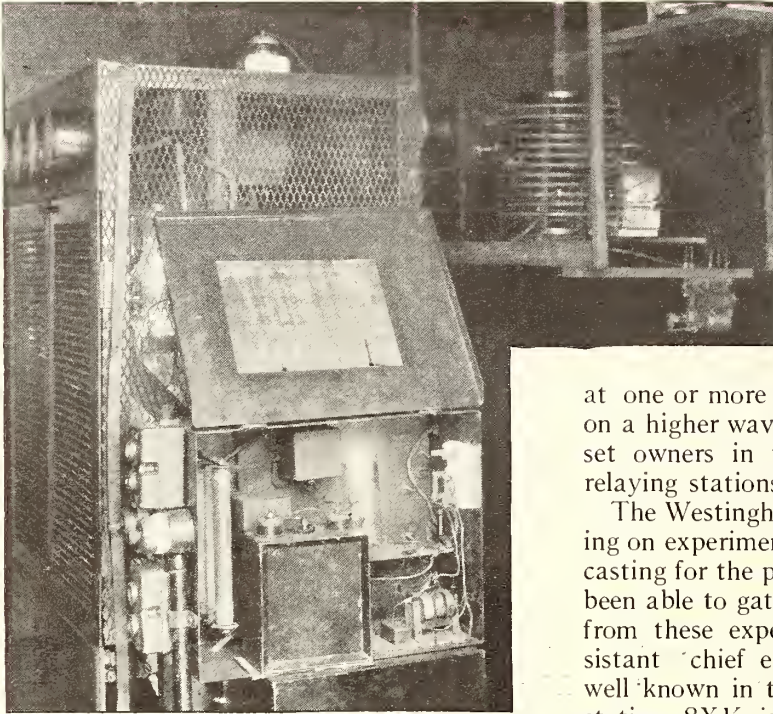

THE 100-METER VOICE AMPLIFIER AT KDKA

interested. Mr. H. P. Davis, vice-president of the Westinghouse Company, is said to be the first to suggest national broadcasting. His plan involves: "The establishment of public broadcasting on the same basis as other public utilities, with an Interstate Radio Commission and, therefore, a Federal Commission created by presidential appointment. This commission would be vested with full power and authority to make regulations and enforce them to the full extent. A transmitting license would then take on the nature of a franchise because of the large expense necessary in establishing a high-class station. There would be established two classes of broadcasting stations. First, the stations national in scope, and second, local stations serving particular districts. The local stations could be made non-interfering by the allocation of different wave bands."

This plan, of course, must be worked out in all its various phases, a task requiring great attention to details and the solving of many engineering problems incidental to its perfection. One difficulty, which has possibly already occurred to you is the fact that the small receiving set, especially if it is of the crystal detector type, would be unable to pick out the long-distance stations, and would therefore be

quite out of the radio world. Here is where short-wave relaying supplies the missing link between the large national station and the small receiver.

Just what is the plan of short-wave relaying? Briefly, it is the broadcasting of programs on a wavelength below 100 meters, to be picked up

at one or more distant stations and relayed on a higher wavelength to serve the receiving-set owners in the districts surrounding the relaying stations.

The Westinghouse Company has been carrying on experiments with this method of broadcasting for the past year and has, in that time, been able to gather a great deal of useful data from these experiments. Frank Conrad, assistant chief engineer of the company, and well known in the radio world because of his station, 8XK, is believed to be the man who first experimented with broadcasting on these very short wavelengths. Before Mr. Conrad got into the work, radio engineers had proved by mathematics that transmission on short waves was impracticable, but he had an idea that their calculations might not be correct, and decided to investigate for himself the possibilities of broadcasting effectively on wavelengths of 100 meters or lower. First, he built a set to transmit on 100 meters and found by tests with an amateur operator in Boston that the 100-meter wavelength was more selective and more efficient than even 360 meters. Mr. Conrad next arranged for a private telephone connection between Station KDKA and his home, about four miles distant, and by a special circuit arranged to receive programs from the studio circuit over his telephone line. He then connected this telephone line to his 100-meter transmitting set and sent out KDKA's programs simultaneously with the broadcasting on 360 meters.

In Boston and other places it was reported that this transmission was stronger than the signals received directly from KDKA on 360 meters! This was true, even though his station was much less powerful than the one at East Pittsburgh.

With these facts in mind, the Westinghouse radio engineering department decided to try



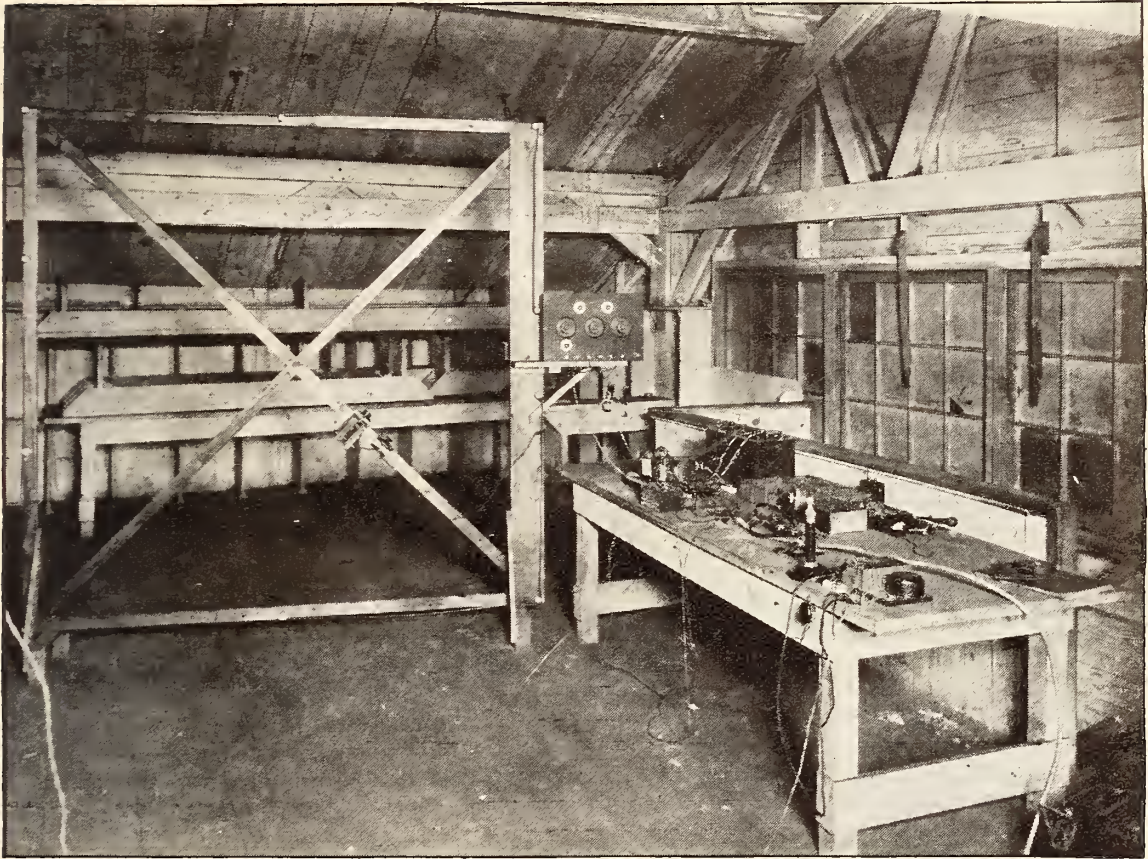

THE LOOP-AND RECEIVING SET AT THE CLEVELAND STATION, KDPM

This is where the broadcasts, sent from KDKA on 100 meters, were received

experiments with Cleveland, where the broadcasts from KDKA on 360 meters, had never been satisfactorily received. To that end a relaying station was established in the Cleveland Foundry, located on the Lake end of West 58th St., and the short-wave relaying tried out. It was not long before Cleveland fans were reported receiving signals from KDKA with the same volume as they were receiving local broadcasting.

The same thing is now going to be tried out in the Springfield station as an adjunct to the programs broadcasted from WBZ.

The mechanics of relaying presented a great many problems which had to be worked out gradually as they presented themselves.

In order to carry on this short-wave relaying, it was thought best to employ two transmitters controlled from the same microphone, one transmitter operating on 360 meters, the other on 100 meters. This was done and now there are also two antennas—KDKA's long antenna

which is 105 feet high and 200 feet long, used for broadcasting on 360 meters, and the short-wave antenna which is 35 feet high and 40 feet long, used, of course, for sending the 100-meter signals.

In Cleveland, the 100-meter signals are received on a loop eight feet square, for the reason that the ordinary inverted L antenna might throw the receiving station out of tune if it swung in the wind. This antenna is located inside the building and is connected to a single-circuit detector unit, with two stages of amplification. The output of the receiver is delivered directly to a 250-watt transmitting set, containing one oscillating and one modulating tube. The transmitting antenna is duplicate of the one at East Pittsburgh used for sending on 360 meters (105 feet high and 200 feet long.)

Naturally there are difficulties encountered in relaying these short-wave signals. For instance, the small size inductances and capacities are difficult to construct. A slight



change, like the swinging of the antenna, will change the wavelength and throw the receiver out of tune. On the other hand, the efficiency on 100 meters or lower is comparatively high, on account of the lower electric losses which permit greater radiation from a given antenna at the same power input than is possible when sending on 360 meters.

Perhaps the principal reason why short-wave broadcasting will prove important in future radio telephone stations is that it will open up a great range of wavelength bands. This is, of course, irrespective of the possibilities of national broadcasting. For instance, there are only 25 wavelength bands, each 10,000 cycles wide, between 300 and 400 meters, whereas there are 300 such bands between the wavelengths of 50 to 100 meters. This fact may lead to the solution of the interference problem that confronts broadcasting as we know it to-day.

There are other things to be taken into consideration which show that the lower wavelengths have some very desirable characteristics. It has been observed that static is less noticeable than on 360 meters. This was found to be true when the same concert was heard simultaneously on 360 meters and 100 meters. A dash of static that would completely drown out the 360-meters broadcasting would scarcely be noticeable on the 100-meter wavelength.

Another advantage, indicated by these tests is that daylight does not reduce the range of the short-wave broadcasting as it does when the 360-meter wavelength is used. At direct variance with the system in use to-day, first tests have shown that daylight transmission is materially better than night transmission at a wavelength of 80 meters. It is believed, though still unproven, that there will not be the falling off in distance in the summer time which is one of the handicaps of broadcasting at present.

There are, to be sure, some drawbacks to broadcasting on extremely short waves. The most serious is that the receiver gets out of tune very easily. This is frequently due to the swinging of the antenna, but this sort of trouble could be easily reduced by using some sort of fixed antenna, or a loop such as is used at KDPM.

Mr. Davis has already suggested the relay, by stations of limited power, of concerts broadcasted from a powerful central station, so that the whole country might listen to the same concert. That such a plan is feasible for a comparatively small area, the Westinghouse Company's experiments have proved; and since the theory itself is known to be sound, it seems that the development of a national broadcasting system can be a matter of only a few years.



#### ANOTHER "CAVE MAN"

Mr. N. M. McCoy, of Monmouth, Illinois, sends us this picture, and says: "Talk about cave-man stuff—how does this set look to you? Cigar boxes nailed on a board, for a panel. Have listened-in on most every station from Minneapolis to Atlanta and from Newpark to Dallas! I enjoyed Mr. Tannehill's article [RADIO BROADCAST for February, 1923] very much and have had all his experiences and then some. He says: 'buy your parts, tie them together, part your hair in the middle, and go after Havana.' I can't part my hair in the middle; but I have seen the time when if the second hand on my watch had stopped I know I would have made the station."



# The Best Battery Connections for the Circuit You Use

Perhaps Your Tubes Are Not Working at Their Best. Different Arrangements of A and B Batteries are Necessary for Best Operation of a Tube When Used as Detector and When Used as Amplifier. Check Up Your Own Circuit

BY EDWARD LINDLEY BOWLES

Instructor in Electrical Communication, Massachusetts Institution of Technology

**A**T THE present time, there seems to be much confusion in the arrangement of A batteries in vacuum-tube circuits. One detector circuit may be shown with the grid connected to the positive side of the A battery, whereas another detector circuit of the same nature may be shown with the grid connected to the negative side. The same is true in the case of audio-frequency amplifiers. And the negative terminal of the B battery is usually connected to the negative side of the A battery for no apparent reason other than that it is the custom.

In many descriptions of circuits, the reader is confronted with the expression "at zero grid potential," or "with a grid potential of minus 1 volt"—another means of expressing the same thing—or "a negative bias of 1 volt." One may well question the exact meaning of these terms, if the grid can be arbitrarily connected to the positive or negative side of the A battery.

In order that the characteristics of a vacuum tube may be clearly defined, it is customary to state them in terms of connections made to the negative side of the A battery. In this way, you can clearly understand that if the grid of a vacuum tube is said to have a negative potential of 1 volt, it is 1 volt more negative than the side of the filament connected directly to the negative terminal of the A battery. But here

again a question may arise, for circuit drawings are shown with the filament rheostat sometimes in the positive, sometimes in the negative, side of the filament circuit. If the filament rheostat is in the negative filament lead, then, even though the grid is connected to the negative

side of the filament battery, it is not at the same electrical potential as the negative side of the filament. In actual practice, there are sometimes certain advantages in placing the filament rheostat in one particular side of the filament circuit. Again, there may be particular advantage in connecting the grid to a particular side of the filament battery. The reasons for special arrangements of connections to the A and B batteries can be

made clear by a few simple diagrams.

In Fig. 1, a vacuum tube is shown with all batteries connected. The voltmeter, in the grid circuit (Fig. 1) indicates the potential of the grid with respect to the negative end of the filament. When the grid is connected directly to the negative end of the filament, that is, when the C battery is removed from the grid circuit and the point M is directly connected to the point N, the grid is said to be at zero potential. It must be remembered that it is at zero potential only with respect to the point H of the filament. The point K of the filament is more positive than the point H, since it is closer to the positive side of the A battery.

## Do You Know:

Why a rheostat is placed in the positive filament lead in some circuits and in the negative lead in others?

Why the negative terminal of the B battery is sometimes connected to the positive and sometimes to the negative terminal of the A battery?

What determines your grid potential, and what effect has it on your circuit?

Why a potentiometer is used with a "soft" detector tube such as the UV-200, and not with the WD-11?

How to make the proper connections for various tubes used as detectors and amplifiers?

If not, this article will be of interest and value to you.

Keep it handy.—THE EDITOR.

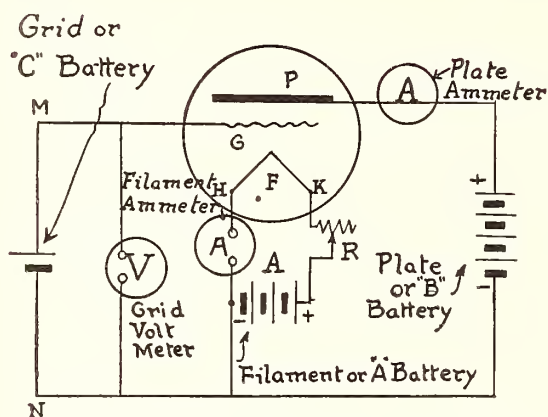

FIG. 1

The fundamental vacuum-tube circuit from which plate, grid and filament voltages for the proper operation of various types of tubes may be ascertained

Whenever the characteristic curves of vacuum tubes are referred to, they are obtained by the standard connections shown in Fig. 1.

It does not follow, from this discussion, that the connections of the batteries shown in Fig. 1 are best for practical applications of the vacuum tube. Where a hard tube is used as a detector it is unnecessary to connect the negative side of the B battery to the negative side of the A battery. Very often it is of advantage to connect the negative side of the B battery to the positive side of the A battery so as to have the advantage of augmenting the B battery voltage by the A battery voltage. Also, it is usually more satisfactory to connect the grid of the detector tube to the positive side of the A battery, because a detector tube usually works best when the A battery tends to make the grid slightly positive. Connections for a hard detector tube, such as the UV-201-A, the WD-11,

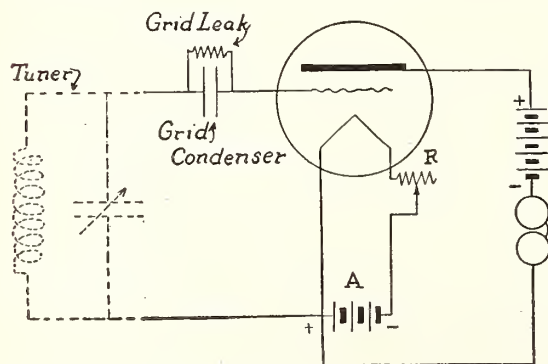

FIG. 2

When a hard tube such as a WD-11, C-300, C-301-A, UV-199, UV-201, or UV-201-A, is used as a detector, this circuit arrangement may be used

or the VT-2, are shown in Fig. 2. In this case, the grid is connected to the positive side of the A battery. The plate, or B battery, is also connected to the positive side of the A battery, and the filament rheostat R is placed in the negative side of the filament. In this way, any variation in the filament current does not affect the potential of the grid as much as if the filament rheostat were placed in the positive filament lead.

Figure 3 shows a detector circuit arranged for using a soft detector tube, such as the UV-200. In this case the grid is once more connected to the positive side of the A battery and the rheostat is placed in the negative filament lead. Since this type of tube is very sensitive to a change in plate voltage, a potentiometer, P, is inserted as shown. Under these conditions, if an 18-volt tap is taken on the B bat-

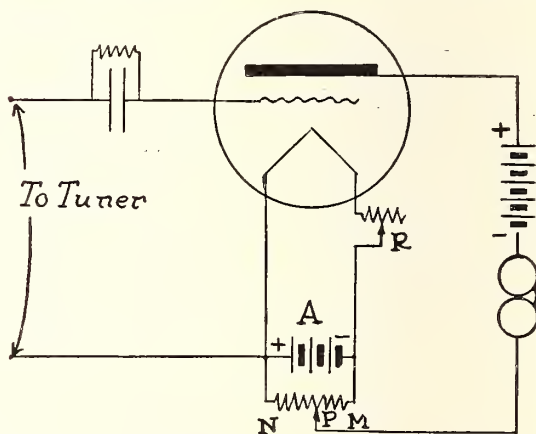

FIG. 3

When using a soft detector tube, such as the C-300, UV-200 or some of the old De Forest, Audiotron and A-P tubes, this circuit arrangement is better than the detector circuit shown in Fig. 2

tery, then if the potentiometer slider is at the point N, the plate will have a potential of 24 volts (if a 6-volt A battery is used). When the potentiometer slider is at the point M, the plate will have a potential of about 17 volts (owing to a drop of about 1 volt in the filament rheostat). By this arrangement the plate potential can be adjusted to an optimum operating value, as required by the particular tube in the socket.

In the case of an amplifier, the problem is a different one. As long as the grid of the amplifier tube is positive, distortion will take place. In fact, in many cases it is necessary to give the grid a decided negative potential, with respect



to the most negative end of the filament, in order that efficient and relatively distortionless amplification may be obtained. It is also of advantage to operate an amplifier tube at a higher potential than a detector tube. Therefore, the negative end of the plate battery might just as well be connected to the positive side of the A battery in order that the plate voltage may be augmented by that of the filament battery.

Figure 4 illustrates the connection of the A and B batteries in the case of an amplifier tube. The grid connects to the negative side of the A battery. The filament rheostat R is also placed in the negative side of the filament battery. The negative side of the B battery is connected to the positive side of the A battery. The insertion of the filament rheostat in the negative side of the filament has the advantage of giving the grid a slight negative potential. In fact, if a 6-volt A battery is used, where the actual filament voltage required is only 5, there will be a 1-volt drop in the filament rheostat. This means that the point D is one volt more positive than the point E, which is the most negative point on the circuit. An audio-frequency amplifier will operate better with the filament rheostat in this position, since the grid will be automatically given a slight negative bias. The disadvantage which attends this arrangement lies in the fact that, as the A battery discharges, less and less of the rheostat resistance is required. When the A battery has reached a potential, let us say, of that actually required by the tube itself, then all the resistance will have been cut out of the rheostat and the grid will have no negative potential or "bias."

Many commercial amplifiers, either radio-frequency or audio-frequency, cannot incorporate this arrangement having a filament resistance inserted in the negative side of the filament lead, because there are certain patents, held by one of the large corporations, which preclude the use of it.

Another arrangement for an amplifier circuit is shown in Figure 5. In this case, a C or grid biasing battery is used, so that the grid may be given any negative potential desired simply by inserting the proper number of cells in the C battery. Flashlight cells are very convenient for this purpose, because of their small size. The approximate electromotive force of such cell is  $1\frac{1}{2}$  volts. Cells used in the C battery should be placed as close to the A battery as

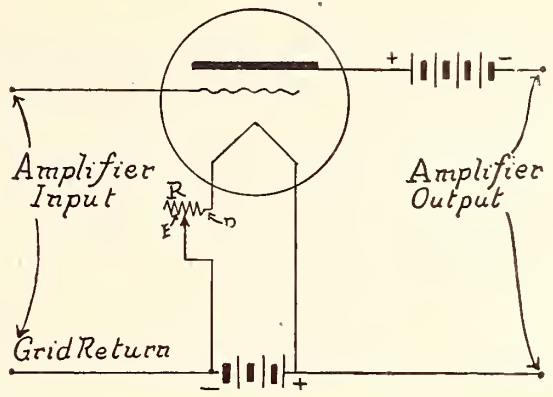

FIG. 4

In amplifier circuits, hard tubes should always be used and this circuit arrangement may be used to advantage. A negative bias, equal to the voltage drop across the filament rheostat, is automatically imposed on the grid. If the A battery is kept well charged, the use of a C battery is usually unnecessary where this circuit is employed

possible, and should not be placed near the grid, as shown by the point H.

Various tubes require various negative biases when used as amplifiers. The new 201-A tube requires from -0.5 to -5 volts, depending upon the plate voltage. The Western Electric VT-1's require from 0 to -3. The Western Electric 216 -A tube, which is used in the W.E. power amplifier, requires a bias of approximately -6 volts, and the WD-11 requires a bias of from 0 to -4.

Figure 6 shows the use of a stabilizer or potentiometer. By the use of this device, the grid bias may be varied when the tube is under

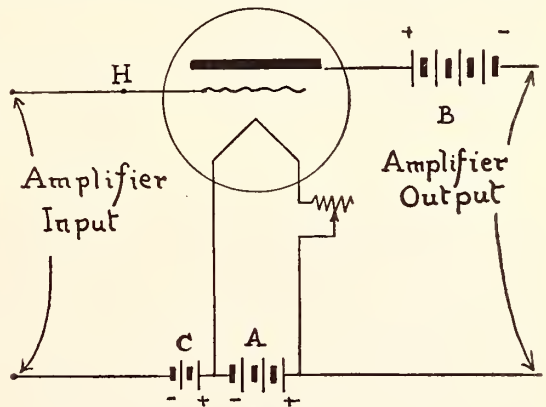

FIG. 5

The value of the negative potential applied to the grid may be varied by manipulation of the number of cells in the C battery in this circuit. The connection between the A and C batteries should be as short as possible. The rheostat, in this instance, is in the positive lead of the A battery

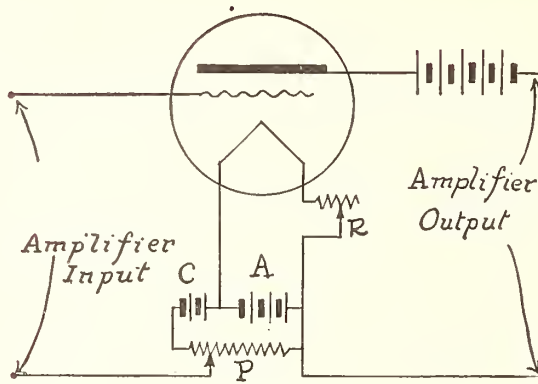

FIG. 6

The best arrangement for amplifier tubes is shown here. By means of the 400-ohm potentiometer it is possible to procure the best value of grid voltage for the operation of the particular tube you are using

operation, so that the optimum point of operation may be readily secured. A potentiometer of comparatively high resistance must be used for this purpose, as otherwise the loss, due to the steady current sent through it by the A and C batteries, which are in series, may become expensive and objectionable.

The A battery may consist of dry cells, in the case where WD-11 or UV-201-A tubes are used, but it will probably be a storage battery, since several or either of these tubes may be operated in parallel. The C battery can be made up of ordinary dry cells, since flashlight batteries will wear out very much sooner in circuits where a potentiometer is used, as in figure 6. For example, if the resistance of the potentiometer is 400 ohms, then for a 6-volt A battery and a 4-volt C battery, there will be 25 milliamperes flowing during the period when the tube is in operation.

Figure 7 illustrates the use of a soft detector tube in conjunction with two stages of audio-frequency amplification, in which UV-201-A tubes are used. The potentiometer P furnishes the necessary fine variation in plate voltage for the proper operation of the soft detector tube. The plate lead of the detector tube is connected to the primary of the first audio-frequency

transformer, and then to the 22½-volt tap on the B battery. The grids of the two amplifying tubes are given a negative bias of from -1 to -4.5 volts by means of the biasing battery shown. This particular battery may consist best of a flashlight type, for, as it carries almost no current, its life will be practically its "shelf life." The jacks enable the operator to utilize the detector tube alone, or the detector tube in conjunction with one or both of the stages of amplification. The plate potential of the two amplifier tubes varies from 60 to 80 volts. A potential of 60 volts will probably be ample, unless the receivers are replaced by a loud-speaking device. Beyond a certain point, there is little advantage in increasing the plate voltage. The biasing battery has a tendency to increase the intensity of the signals over certain ranges of frequency, but with ordinary amplifying transformers, the improvement, due to the insertion of the C battery, may produce comparative distortion, because it will tend to make the amplifier operate more powerfully for certain frequencies, and no better for others.

Figure 8 shows a similar circuit, to be used with three WD-11 tubes, the first tube acting as a detector. In this case, there is no potentiometer in the detector-tube circuit, since the detector-tube plate voltage is not critical. The grid bias is furnished by the necessary number of flashlight cells, inserted as shown by C in the figure. WD-11 tubes will work very well without any biasing battery, but under these

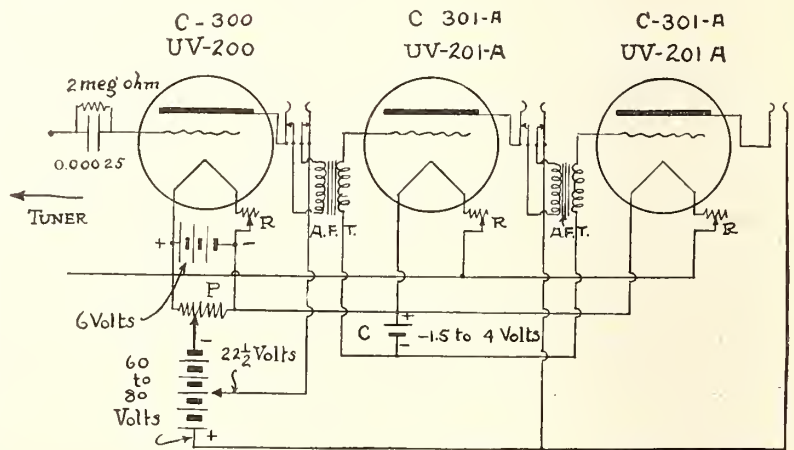

FIG. 7

This is a detector and two-stage audio amplifier circuit which may be made of standard parts and applied to any receiver. The detector tube should be soft, such as the C-300, UV-200, Moorehead, Audiotron, or De Forest detector type. Any hard tubes may be used in the amplifier circuit



conditions it would be better to put the filament rheostats in the negative filament leads of the two amplifying tubes shown. In the figure, the rheostats are placed in the positive filament leads of the two tubes, owing to the insertion of the "C," or biasing battery.

Where the battery arrangement shown in figure 7 is used in a radio-frequency amplifier circuit, the circuit will probably be subject to oscillation the moment the grid becomes the least bit negative, so that the C battery shown is hardly necessary. Logically, it would be ideal to operate the tube with a negative grid potential, but in the case of most radio-frequency amplifiers, the grid must be made slightly positive in order to introduce a loss, which will keep the circuit from oscillating. Any mechanical or electrical system will vibrate if it is once excited, as long as the resistance, or the friction in the circuit, is below a certain value. However, if the resistance is increased, then the system will cease to oscillate. This is evident, for example, in the case of the pendulum of a clock. If the pendulum of a clock is once pulled aside, it will oscillate for some time, even though the clock may not be wound. If the clock is wound, the spring furnishes energy to the pendulum as fast as it is lost to the friction, so that the pendulum continues to oscillate. However, if the pendulum were immersed in some very viscous liquid, then, even

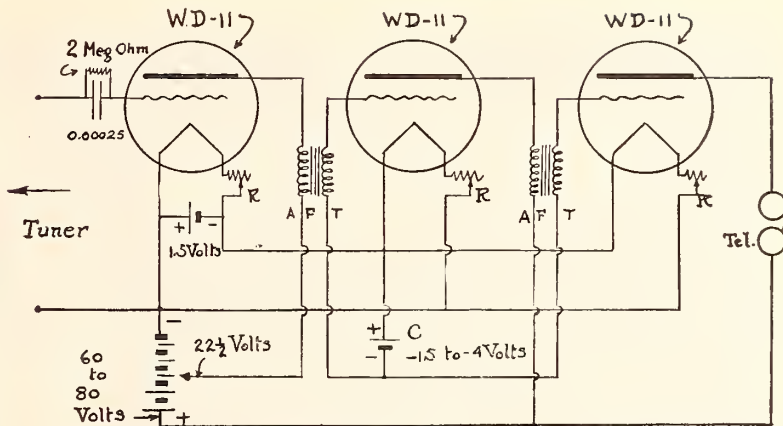

FIG. 8

Three WD-11 tubes are used in this circuit. If the C battery is not employed, it is better to place the filament rheostats for the two amplifier tubes in the negative lead of the A battery, instead of the positive as shown here

though it were given an impulse, it would not oscillate at all.

A C battery in the ordinary radio-frequency circuit is of no use, for the losses just mentioned must be introduced in order to keep the circuit from sliding. In the case of audio-frequency amplification, the results will be very disappointing if the grid is connected to the positive side of the A battery, but very satisfactory if the grid is given a negative bias of the proper amount.

The various arrangements shown illustrate the possible interconnections of the A and B batteries, and from an inspection of them, it should be clear that most circuits, as popularly shown, have been arranged subject to statements made in advanced treatments of vacuum tubes, in which the standard circuit shown in Fig. 1 is used as a standard basis for comparison only.

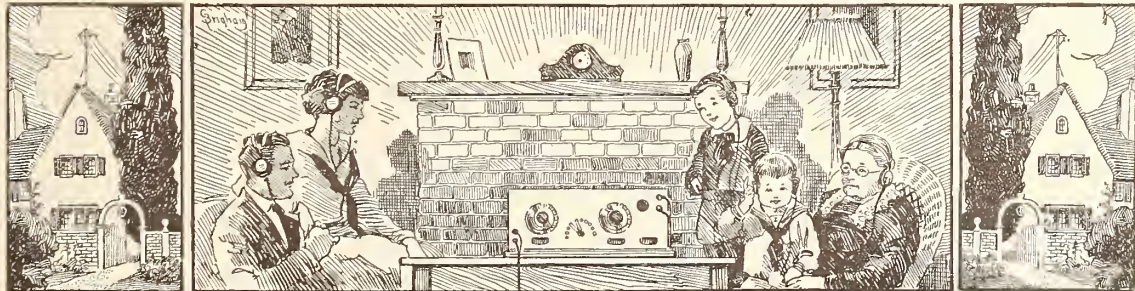

# A Man Who Built A Set He Has Never Seen

By ALFRED M. CADDELL

ONE sunshiny day in September, 1899, a police officer patrolling the streets in the Harlem district of New York heard the cry "Help! Help!" coming from a tenement house. Rushing into the darkened hallway, he hurried up the stairs. Suddenly a shot rang out, followed by another shot—and then the whole world became dark to him.

The officer was taken to the Harlem hospital. The best doctors in the city were rushed to his side. One of the bullets had entered his chest; but the other had penetrated his eyes and wrought such havoc that both of them had to be removed, depriving him of his sight forever.

That was almost a quarter century ago and during all the intervening years the likeness of no new object has come into this ex-policeman's life. But since that day he has done some remarkable things, not the least of which has been to construct a radio receiving set totally unassisted by any one except his twelve-year-old boy who read aloud various radio items and plans culled from newspapers and magazines!

Patrick O'Keefe was born in the Harlem district forty-eight years ago. He received his education in the public schools—that is, up to the age of eleven—and then started out to make his own living. Telegraphy sent out a call to him, and soon he became very proficient in the Morse code. He acquired a typewriter and

learned to write via the system of "hunt and peck." But presently telegraphy lost its charm as a vocation for a young man of such powerful physique. He was very active. He must be out of doors, and so on the 24th day of October, 1896, he became a member of New York's guardian police force.

Little could Officer O'Keefe realize, when he plunged into that dark tenement hall to investigate the cause of the disturbance, that those few moments would mark the passing of his sight. And throughout the following twenty-four years, or until the broadcasting wave swept over the land, little did he dream that he would travel to foreign shores and enjoy the scenery—via radio.

The other evening I called upon him in his Harlem home and heard his story. And he told it in a way that only a man who

had actually lived through the privations of the blind could possibly have told it. Not a man given to self-pity and complaint—on the contrary, as thoroughly buoyant in spirits and health as people with the sense of sight, perhaps more so. A man of the world, with a strong grasp of the hand and a strong grasp on the affairs of the world. For as he sat and talked, and laughed and smoked, one could not help seeing that he had a feel on nature's finer things.

"Nature," he said, "has some wonderful compensating laws. When a man's sense of sight is taken away, the remaining senses come

Radio can and should be a permanent and increasing blessing to those who cannot see. It is the one best way in which the blind can lose the sense of remoteness from the lives of other people, and can enjoy the manifold activities which engage a busy world.

No doubt the manual skill and the power of visualization possessed by Mr. O'Keefe are qualities not found in all blind people. But whether they make their own sets or not, they should be introduced to the advantages that radio can bring them. As Mr. O'Keefe says, "Let the blind be thankful that radio is at hand—and also, *let them use it.*"

Those who can afford their own apparatus will find their investments a thousand times repaid; and as for those who cannot, especially those who spend their lives in institutions for the blind, we can only hope that the more fortunate and wealthy will appreciate the unparalleled opportunity they have for doing good.—THE EDITOR.



to the rescue, and become ever so much more acute. And, too, the loss of sight stimulates caution, easiness, patience—never a loss without some gain. Instead of the eye observing a panorama of things, a man's reason becomes better developed, and his nervous energy greatly conserved. Of course, the loss of sight is a great handicap, but I soon became accustomed to it. It wasn't long before I was taking long hikes to Westchester, wrestling with the boys, swimming, fishing, and otherwise enjoying myself in the sunshine and air. Several years after this handicap came upon me, I married, and my wife and children became the joy of my life.

"When did you become interested in radio?" the writer asked.

"Just about a year ago. Contrary to the custom of many blind folks who become more or less clannish and stay by themselves, I have always mingled with people who read the top-

ics of the day. Or sometimes friends drop in with a few cigars and try to tease me. 'What kind of a cigar is this?' they will ask, just to see if I can tell by the aroma. Or else they will drop in to tell me what is going on at the club. On one of these occasions a friend told me about the development of radio, and related some of the wonderful things that could be taken out of the air—concerts, lectures, travel talks, stories, baseball scores, and code. And then my boy read from the newspapers what was going on in that line. I didn't know very much about how the thing worked, but the thought of listening to good music and the possible educational value of the lectures proved entirely too much for me, and I determined to find out something about this thing and to build myself a set.

"In my early days I had studied telegraphy and of course became familiar with batteries,



OPERATING THE SET HE MADE HIMSELF

Mr. O'Keefe, lost his sight twenty-four years ago. "No one knows the amount of good I get out of this little set," he says, "and no one can know but myself, for it is like an emotion—very hard to explain"

circuits and that sort of thing. And I understood a good deal about the telephone. So it came down to the point of cost and actual construction. Naturally, in my circumstances I had to confine myself to a crystal set, and I like the crystal very much. My boy read to me how to make the primary and secondary coils, how to mount the slide tuner, how to connect the crystal, coil, condenser, and phones in the circuit, and gradually I began to visualize in my mind just how the thing could be done.

"Visualization is half the battle. Also I began to comprehend inductance and capacity and to see why different taps had to be taken from the secondary in order to tune in on different wavelengths. And then came the condenser, detector, phones, and aerial—all this I got firmly in my mind and then proceeded to make a loose-coupler type of set.

"I had been handy with tools all my life, and had always derived a great deal of pleasure with a jack-knife. In fact, one of the first things I made after I lost my sight was a wooden chain which I had whittled out of a stick, and the keeper of the hotel where I was staying up in the Catskills liked it so much that he had it gilded and hung on the wall—not because of the beauty of the thing, perhaps, but because a blind man had made it. That called for visualizing a chain, and very careful carving in order to avoid spoiling the links. Then again some of the neighbors have brought in their clocks for me to fix, and other similar jobs, so all in all I have kept in pretty good trim. And with it I developed a sense of proportion and design, and as I set about the task of building my radio set I could see it being developed step by step—see it almost as well as a man with eyes.



"Dimensions of course were the principal thing. The secondary had to fit into the primary. I had to make calculations for the end boards, the stand it was to rest on, wire the coils, bolt on my condenser, the detector, insert my posts, connect to the aerial and so on. The set you see here is a loose-coupler type crystal set with a 43-plate condenser shunted across the secondary. It was the first set I built, but since then I have built three others—one for a girl across the street and two others for boys. I enjoy it immensely—there is nothing like being employed, no matter whether you are blind or not. It saves people from brooding and pitying themselves—self-pity is the worst affliction that can befall a man. What I have done, others can do, and they will be all the better for it, and if you publish this interview I hope it will reach the ears of blind folks so that they may learn of the advantages of radio.

"First, in the actual construction of my set, I started with the base board, visualizing where the coils ought to be, the condenser, the detector and where the lead-in and ground posts should be. I sawed this board from the solid end of a box, using a square to get the saw started straight, and applying it frequently to the board to learn if I was making a good job. Then for legs for the set I got hold of four base-board bumpers that folks sometime screw onto a door near the bottom to prevent the knob bruising the wall paper and plaster. Besides being about the right height—three inches or so

—they have rubber tips and come so nicely carved all ready to screw on that one wouldn't want anything better for legs. Then I sandpapered them and set about building my coils.

"That is where one of the things belonging to my wife came in—the much abused rolling pin. Besides proving wonderful kitchen night-sticks and pie-crust rollers, they are ideal for the winding of a coil—at least, it was so with me. My boy got a soap box for me and I cut out a small section on both sides, about two inches deep, to form sockets for the ends of the rolling pin to fit in. In a way, this acted as an improvised lathe. Then I ran the rolling pin through the cardboard cylinder on which was to be wound the coil. This proved a very good fit, and when the pin was set in the niches of the box I could turn it very steadily and evenly with one hand and guide the wire with the

other, and thus I wound my primary coil. The secondary of course was a little harder proposition because I had to jab holes through the cardboard with a hat pin every ten loops and lead the wire ends through, for taps to the switch points.

"The end board itself was a little difficult to make because I did not have an auger large enough to bore a  $3\frac{1}{2}$ -inch hole. But my youngster had one of those model building sets with which you can build towers and bridges and things. In this set were several small pieces of steel with a number of perforated holes half an inch apart. Taking two pieces of steel, I set an old Gillette safety-razor blade between them and bolted the steel and blade together. Little axles and collars also come with a building set, so I screwed a collar to the board, saw that my safety-razor blade was  $1\frac{3}{4}$  inches away, or half the diameter of the hole, and then swung it round and round like a compass knife, cutting deeper and deeper each time until finally I had cut all the way through the board. Right here, however, comes a joke on me—after I had spent the best part of a day making that  $3\frac{1}{2}$ -inch hole, I found out I could have bought an end board with a hole already in it for five cents! But I had the fun of figuring out a device for making it, anyway.

"The next step was to mount the condenser. This called for holes to be drilled in order to bolt the blade part to the meter scale. Drilling holes straight was a little difficult, but I managed to do it with the aid of a cardboard pat-



tern and a good deal of patience. The holes had to be straight in order to make the two parts jibe, and I certainly wanted the set to look as though a workman had constructed it, and if it looks the way I have visualized it, it must be O. K.

"Finding a sensitive spot on the crystal also proved a tedious proposition. Finally I got it with the aid of a buzzer, which also lets me know whether my tuner is in contact with the coil or not. Funny thing about these crystals. They seem very temperamental and shy. You never know where a sensitive spot might be, and after you get it you never know the reason why. I remember working practically the whole of one evening trying to find a sensitive spot on my crystal and was about to give it up and go to bed when a sudden little jar with my knee found the sensitive spot for me. I had the phones on my ears, and right away got the surprise of my life. I was tuned in at 360 meters and the first

thing I heard was the name 'Patrick' coming over in code. Patrick is my name, but why it should be the first thing to come through or who sent it I do not know. Anyway, Patrick had found the sensitive spot on the crystal, and Patrick sat up until way long into the night listening to one of the best concerts he had ever heard."

Thereupon Mr. O'Keefe went on to tell of his experience with aerials. His first aerial was a wire that he ran out on the pulleys of the family clothes line. This proved rather weak. Then he tried running a wire around the house, and on the roof of the house, but it was dangerous for him to walk around an unguarded roof. Finally, he came to the use of a device which he screws into an electric light socket, the wiring circuit of the house acting as the aerial. This system has given excellent results, and inasmuch as he uses a condenser which is shunted across the secondary, and also a phone condenser, he is able to tune quite sharply. Altogether, his is one of the best arranged home-made crystal sets that the writer has ever seen, neatly constructed and yet as simple as can be.

"Painting was the only part of the work I didn't do myself," he said. "I wanted the set to look O. K., and while I could gather how it looked by the feel, I could not paint that way—that is, I didn't want to be putting my fingers on the painted surface to guide me in the work, so my boy painted it for me."

"What was the total cost of the set?" I asked.

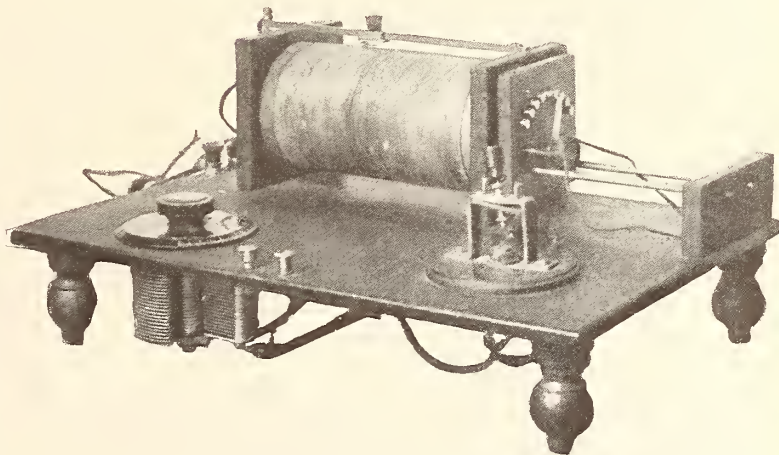

THE CRYSTAL SET WHICH MR. O'KEEFE MADE BUT HAS NEVER SEEN

It is almost inconceivable that a man who is totally blind can build a complete radio set unassisted, including winding the coils, and doing all the wood working. The secondary was wound over a rolling-pin; the legs of the platform are door-stops. Mr. O'Keefe cut the  $3\frac{1}{2}$ " hole in the loose-coupler end-piece with an improvised device employing a safety razor blade

"A little less than \$5.00," was the reply. "The condenser was the most expensive part of it, but it is worth all it cost as it helps me to tune out a station I don't happen to want. The phones are only a makeshift, but I make them do. The whole outfit gives very good satisfaction, and of course I get more than an ordinary amount of pleasure out of it on account of having made it myself."

The ex-policeman leaned back in his chair and puffed contentedly at a cigar. He was sitting in his "corner," or as his wife terms it, his "workshop." Directly overhead were his police department certificates. On one side of the chair, next to the mantel of the fireplace, stood a little table covered with tools, wire, and other odds and ends, and attached to this table was a swinging board supporting his present set. It is always within reach, and pretty nearly always in use. For wherever broadcasting is taking place in the metropolitan area here is one man quite willing to listen.

Next to his chair stood a little stool on which were several magazines for the blind, printed in

Braille, or the raised-dot system, various combinations of dots representing different letters in the alphabet. But I learned from Mr. O'Keefe that there is nothing in the literature for the blind pertaining to radio. He said this was most unfortunate, for of all people in the world who stand to benefit from radio the blind would probably head the list.

"I do not like to ask my wife and children to sit down and read to me," he explained. "The wife has her family work to do and the children have to prepare their school lessons, and it would be selfish on my part to take up much of their time. No, I enjoy sitting here a couple of hours at a time listening to what's going on in the world. No one knows the amount of good I get out of this little set, and no one can know but myself, for it is like an emotion—very hard to explain. I am a great lover of music, and certainly get the concerts very clear—that is, unless some fellow with a tube set allows it to oscillate and send out a flock of 'birdies.' But that doesn't happen very often, for I tune pretty sharply, and generally succeed in tuning them out. Music has a wonderful effect on me—simply lifts me right out of everything, and before radio came in I used to make a lot of it myself.

"The trips you can take via radio are certainly great. A short time ago the advertising manager of the American Express Company gave a series of travel talks on tours in foreign lands—and I went with him. I could visualize the foreign peoples he described, their ways of living, and every bit of the wonderful scenery. The Company never knew how much I enjoyed that trip! I have gone completely around the world, and it didn't cost me a cent. And then I went down to the dock on the East River and talked with an old salt who has been in every port in the world, one of those fellows who can describe things beautifully, and he went more into detail about the different places. But wasn't he surprised when I began to tell him all about Australia? He wondered how the deuce I knew!

"But the best sport of all comes from people who don't know they are broadcasting. For instance, at some of these banquets, the speeches are picked up by microphone and re-

layed to a station to be broadcasted. Now the average man doesn't know how sensitive a microphone is, and unwittingly two or three fellows sitting near the microphone will discuss the ladies and drop whispers to one another in a confidential tone. And away, perhaps for thousands of miles, those little confidences will be wafted by the radio waves to fall on listening ears.

"At one of these formal gatherings the toastmaster announced that Charles M. Schwab would speak. Mr. Schwab gave a very fine address, and during the course of it he commenced to laugh. That laugh tickled me, and I remembered it. One evening I heard the same laugh again, and I said to my wife, 'My friend Charlie Schwab is here,' and sure enough he was afterward introduced to speak. He had evidently been sitting near the microphone, unaware that people with phones over their ears were enjoying the merrymaking too.

"The world's series, the big football games, the horse races—all the sports come to me through the air. Last summer, a friend of mine dropped in and I began telling him all about the ball game. 'How did you hear about it?' he asked. He had been to the game that very afternoon himself, and had got soaking wet in the rain, whereas I sat here perfectly contented and heard Grantland Rice say 'Now the pitcher is winding up, and now he lets it go.' And I didn't get wet, either.

"Of course, my machine is limited to a radius of about 25 miles—the more powerful sets bring in the far-away station, but I get as much as I want at that. Next summer a friend and I are going fishing along the North Shore, and I am certainly going to take my little set along and rig up an aerial on the boat.

Yes, indeed, radio is a wonderful boon to humanity, and I look forward to still greater things. Somehow I think that an artificial sense of sight could be stimulated in people who have lost the sight of their eyes. I haven't any worth-while suggestions to offer, but perhaps someone who knows more about radio than I do will discover a method. In the meantime, let the blind be thankful that radio is at hand—and, also, let them use it."

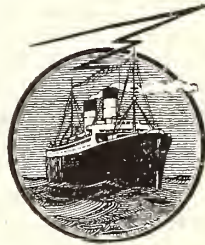



# A Loop Receiver in the Tropics

By CHARLES T. WHITEFIELD

**I** WONDER if many fans have had the fun from a receiver which has been given us by our loop machine. We found it a not considerable package to carry with us on the steamer from New York, and forthwith set it up on deck and attended New York concerts and church services on Sunday to the enjoyment of the passengers.

The apparatus failed us in only one particular. When we moved it to the salon, which is well below decks, it refused to speak—doubtless too much steel between it and the outer world.

From Nassau, in the British West Indies, we get everything 2,000 miles and less north, south, east, and west during the evening, and find it most difficult to get good signals in the daytime; but at night the concerts and lectures come most clearly and the news we pick up from WOO, Philadelphia, is a godsend when news is scarce and from three days to a week late.

Perhaps our most amusing experience was to take the machine to one of the "Out Islands," so called, where wireless was never heard of and the natives were skeptical and superstitious. When we asked them if they would like to go to a church service held in New York, they showed small interest in such "foolish talk"; but when the voice of the minister was heard and the hymns sung by the congregation they thought the end of the world was upon them. They did not at first enjoy the exper-

ience—looked for telegraph wires, and finally gave up in despair as to how the trick was done.

But in the Bahamas, as elsewhere, radio is making its way. A year ago there was not a listening-in amateur in these islands. This year there are well on to six or eight, and the art is spreading. People away from the centres where batteries and parts are sold have no easy time of it. In all the islands you cannot

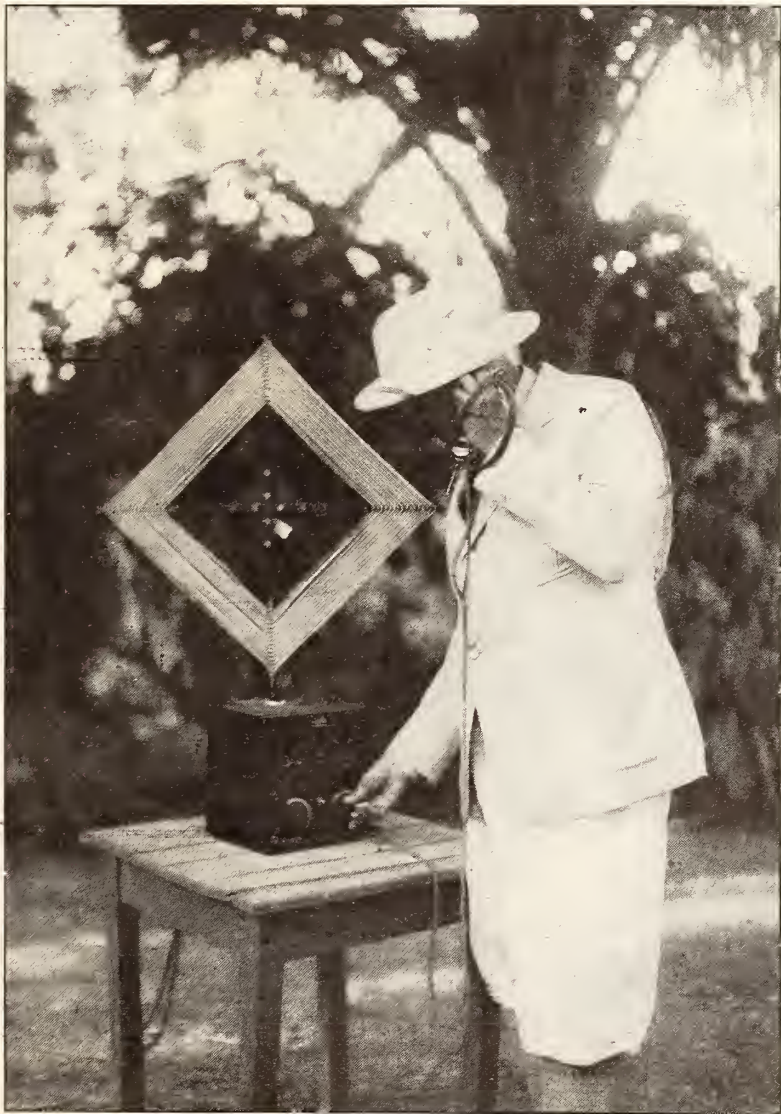

OPERATING THE LOOP RECEIVER IN NASSAU, B. W. I.

buy a tube, a battery, or a head set, or, indeed, any essential part of a radio machine beyond wire, and sets are at a premium. But that condition is changing rapidly because of the great opportunities to hear the outer world perform in a manner which has never been heard of before.

Common report has it—and it is no doubt true—that the Bahamates are the very home of static, and most amateurs shut up shop in April and do not expect to listen in again until November.

I have found the loop aerial much more successful in resisting static than outside aerials. As a matter of fact, so far, to April 1st, it has bothered us not "too much," as the natives say. The one thing that puts us completely out of business is the wireless station on the hill at Nassau. When it starts in to tick off messages to Miami 180 miles away at over 30 cents a word it settles down and drowns us out like flashes of lightning, and we must shut up our telephone headpieces until the messages are complete.

As in England and all British Colonies one can not possess and operate a receiving instrument without a license, and a license is a serious matter. You must apply in writing, and the

matter is then taken up "on behalf of the Governor in Council," and after two weeks or so, if you appear to be a reliable person in good standing, you receive an involved document of three pages. With the license comes a bill for five shillings for a year's use of the machine, and you are at liberty to proceed.

When we set up our machine there was some question about the wire of stringing because of lightning, etc. When it was found out that our set required no wires and gave no sign outside of the house, "The Governor in Council" was perplexed, this being the first loop set ever set up in the Islands.

One's pleasure is often heightened when clear and loud signals come in from northern cities that they are suffering from a blizzard and the performers had difficulty in getting to the station because of the storm, while we sit here in our lightest clothes, with windows and doors open to catch the evening breeze. But we hear, too, from the South. A few nights ago we searched about for the news bulletin and, failing, got Porto Rico, and were informed to our great delight that world news would be distributed. We listened with all our ears, only to hear it all in Spanish, of which not a soul in the room understood a word.



PUTTING "THE TRAVELING SALESMAN" ON THE AIR AT WGY, SCHENECTADY

The scene is laid in a small railroad station—hence the telegraph instrument. The director's phones, padded to exclude all local sounds, are connected to a set outside which is tuned to the concert. By holding up printed cards, he can inform the players how they are "registering"



# With the Broadcasters



EDITH BENNETT

Who sang to Europe from WOR, the Bamberger store at Newark, N. J. She is considered by many as the finest radio singer

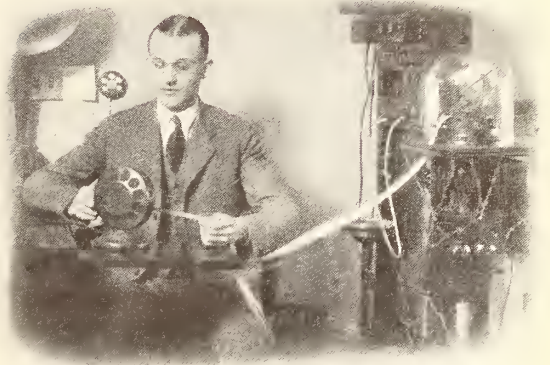

GRAIN PRICES GOING OUT

This ticker at WLAG reports the prices of cash grain and grain for future delivery from the Exchange Room of the Minneapolis Chamber of Commerce



GANNA WALSKA

Grand Opera singer, the wife of Harold McCormick, broadcasting from the Waldorf Astoria studio of WJZ, in New York City



THE "HIRED HAND"

Announcing at WBAP, the *Star-Telegram* station at Fort Worth, Texas. He is president of the Radio Truth Society, with a membership of 10,000 fans

# Protecting Your Invention

First Aid for Those Struck by Patentable Ideas

By ROGER SHERMAN HOAR

Former Assistant Attorney General of Massachusetts

**N**O ONE will deny that "'tis better to be safe than sorry." Suppose that you have an original idea, as some day you may. You do not think that it amounts to much, you have no intention of ever patenting it, you are even reasonably sure that it isn't patentable; and yet it may eventually turn out to be very valuable. Why not play safe and protect your invention from the very start? The fact that you are the original and first inventor will avail you nothing unless you preserve the evidence to prove this fact, and even then you may not be safe unless you take certain further steps.

Therefore, the moment you conceive of a new and useful invention, you should at once prepare an "evidence of conception": i. e., a sketch, signed by the inventor, recording the date of conception, and witnessed by two persons, whose endorsement should read substantially as follows: "(date) Explained to and understood by (signatures)."

Such a sketch should contain, or be accompanied by, a sufficient written description to render the drawing perfectly clear and understandable.

This paper serves several purposes. First, it provides you with two witnesses who can prove your date of conception and date of first disclosure. Then too, it constitutes your first drawing and first written description. Thus you have, in a single document, the means of answering the first four questions which will arise in any interference proceeding, and of proving your answer.

There are many persons who will solemnly inform you that an evidence of conception is invalid unless it is written in ink, signed by two witnesses and acknowledged before a notary. What do they mean, invalid? An evidence of conception is not a Patent-Office form! Furthermore, it has no foundation either in rule or in statute.

The only function of an evidence of conception is to refresh the recollection of one (or both) of the witnesses, so that he can testify

to the dates of conception, drawing, description and disclosure, if necessary, and can make that testimony sound a little more plausible than merely his own uncorroborated word.

If it accomplishes this end, the most informal paper, written in pencil, and signed by a single witness, is sufficient. Even a single witness, without any paper, will do, if he has a good memory and tells a convincing story. But, believe me, his story has got to be convincing! Over three hundred witnesses, produced by Drawbaugh to prove that he invented the telephone before Bell, failed to convince the U. S. Supreme Court, because not one of the witnesses had had the device *explained* to him by Drawbaugh.

So, as a practical matter, rather than as a legal requirement, the more formalities that you can add, within reason, the safer you will be. But note those two words: "within reason." Too much formality is apt to defeat itself by suggesting to the Court that it has been faked to bolster up a weak case. But by far the worst objection is that the greater the formality of a form, the less often will an inventor take the bother to use it. And the evidence of conception should certainly be frequently used.

Among the refinements sometimes employed is the following. The inventor places the paper in an envelope, has the notary seal it, sends it to himself by registered mail, and then doesn't open the envelope until, if ever, it is presented in court.

It is important not only to prepare an evidence of conception, but to prepare it at the earliest possible date. Don't wait for the complete idea to develop, but draw up a paper the moment you have the first hazy outline of your invention. Draw up other papers from time to time, as you work out your details. The most valuable part of your patent will be its broad general claims, and these will be adequately supported by your first general idea.

Your next consideration should be to use due diligence in "reduction to practice," i. e.,



in either building an actual operative machine, or (what is equally effective) filing a patent application. This latter is called "constructive" reduction to practice. Under certain circumstances two months' delay has been held lack of diligence; and eight years has been held diligence; so you see how little the time element has to do with the question.

If you apply for a patent, a diligent reduction to practice is sufficient to entitle you to claim your original conception date. But, if you do *not* apply for a patent, you will have to rely on your first bona fide sale, public use or publication. A fake sale won't do. Hence the importance of selling, using or publishing as early as possible. But this has the disadvantage of starting the running of the two-year period, after which your right to apply for a patent is automatically forfeited. And in the case of publication, there is the additional danger of having your write-up construed as a dedication of your invention to the public. So be sure and include in your write-up a statement that you intend to apply for a patent.

On the whole, therefore, it is much wiser to apply for a patent, even for the mere purpose of retaining your own right to make your own invention. But if you are sure that you do not want a patent, you can effectively play the dog in the manger by publishing a full account of your invention in some magazine. This will render void any patent thereafter conceived; and after two years will render void any patent application thereafter filed, even if conceived prior to your publication.

Beware of permitting the general use of your device prior to your applying for a patent, for this is likely to be construed as a complete abandonment of your invention.

If you decide to apply for a patent, the first

point for you to settle in your own mind is just why you have so decided. Is it because of the fundamental value of the patented novelty; or as a mere scare-crow to keep others from duplicating some distinctive but not particularly patentable feature? Is it to protect yourself in manufacturing your own device? Is it as a mere feeler, to save the expense of an attorney's search of the prior art; or to drag others into an interference, and thus ascertain what are the latest developments along certain lines? Is it to sell the patent, or to secure royalties? Or is it for some other reason? On an intelligent analysis of these questions, at the outset, will depend the handling of the case to the best advantage.

Very often, if your chief desire is merely to keep some one from making a "Chinese copy" of your machine, you can secure a "design patent" on its artistic appearance, even though the machine itself possesses no patentable novelty. But the Patent Office is particularly on its guard against this subterfuge.

If you decide to apply for a patent, you or your attorney must prepare a drawing, a petition, a specification, some claims, and

an oath. These must be gotten up in exact accordance with the "Rules of Practice," a booklet distributed free by the Patent Office. It would pay every inventor to have a copy of this booklet, and to study it frequently. As to whether or not to have a lawyer, and what kind of a lawyer to get, see next month's article.

The Patent Office has some very technical compulsory regulations with regard to drawings, which regulations can be found in the "Rules of Practice." Special printed bristol-board blanks can be purchased through almost any stationer. But what always mystified me about these blanks was: why do they say "INVENTOR" and "ATTORNEYS," when in my

### Patent, Patent, Who's Got the Patent?

It's a great game, according to Mr. Hoar, but you must know how to play it. Many apparently queer tricks are practised for perfectly sound reasons.

Do you know:

Why "most patent lawyers intentionally make several serious misprints in the application?"

Under what conditions an inventor will address and mail a letter to himself?

When it is advisable to make your claims broad, and when narrow?

How to "smoke out a lot of prior art?"

How to avoid "the danger of having your write-up construed as a dedication of your invention to the public?"

This is the third article in a series of four dealing with patents in a clear and practical manner. The other articles are "What Good Is a Patent?" in the April number; "What Can Be Patented?," last month; and "Miscellaneous Considerations," to appear in RADIO BROADCAST for July.—THE EDITOR.

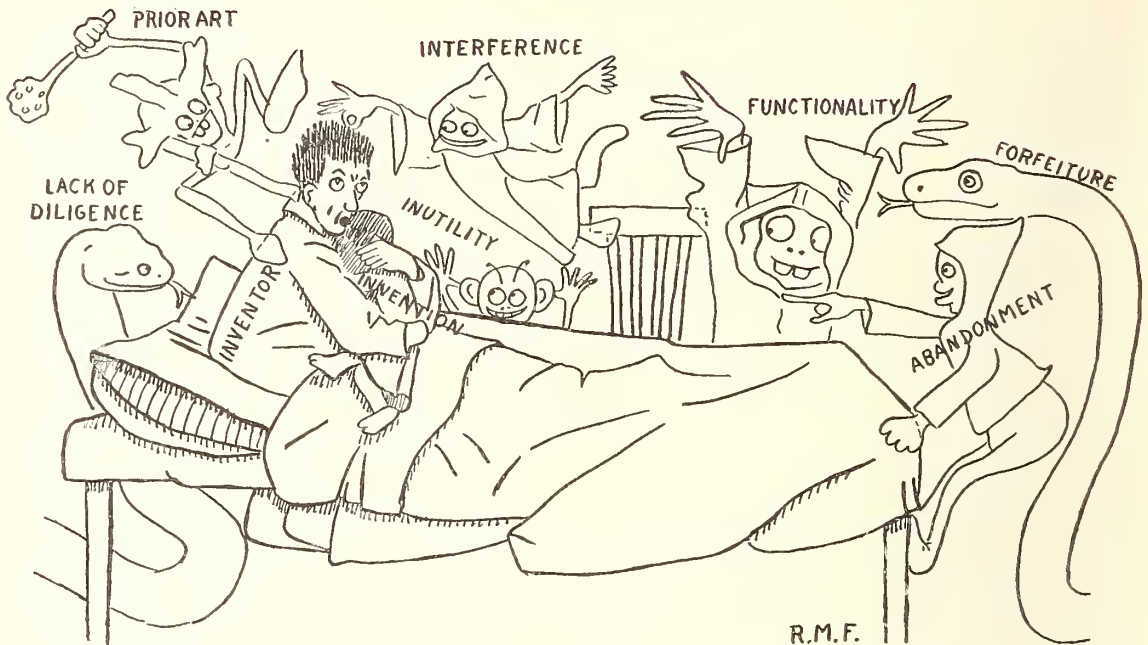

"SEEN' THINGS AT NIGHT"

experience there is usually more than one inventor, and only one attorney?

The petition is a brief formal request for a patent; and, if the applicant has a lawyer, contains his power of attorney, in which case a twenty-five-cent revenue stamp must be affixed.

The specification usually contains a statement of what a hopeless state the art was in before you came along and saved the day with your epoch-making idea, a summary of the principal objects of your invention, an explanation of your drawing, a description of how your device works, and some general language claiming that your invention is not limited to the specific form disclosed by you, but rather is applicable to almost anything under the sun.

The claims are detailed statements of every possible combination of the new ideas involved in your invention. For examples of specifications and claims, study some recent patent obtained by some large corporation, active in the radio patent field.

Ought you to draw the claims broad or narrow? Broad claims are useful to smoke out a lot of prior art, and thus show the inventor exactly where he stands. Also to drag more pending cases into interference, and thus advise you as to what others are doing in the same field. Also to bring into the record some prior patent, which you are afraid that you infringe. This last is often a very important consideration.

You will see, later in this article, that one of the three ways of avoiding a patent cited by the examiner, is to prove that your invention does not infringe it. Your argument is entirely one-sided, as the owner of the earlier patent is not given a chance to present his case. Thus you may be able to get a Patent Office ruling to the effect that you do not infringe this patent, and this ruling will have great weight in your favor, if you are ever called into an actual infringement suit. The advantages of trying your case first in the Patent Office are obvious.

Entirely apart from the above special reasons for making your claims broad, there is the general reason that you naturally wish to get as broad a patent as possible.

But, if you are well acquainted with the prior art, and so realize just how far you can go with valid claims, it may be desirable to draw your claims narrow, for purposes of speed and a clear record. The advantages of a clear record are twofold. First, any infringer of your patent will, of course, try to prove that it is invalid, and his first step will be to secure from Washington the "file wrapper" of your case, i.e. the complete record of office actions and amendments. The less that there is in your file wrapper, the less starting point has your enemy. Secondly, a patent with a clear file wrapper is much more readily salable to the



average manufacturer, due to his ignorance of patent law; although personally I should prefer the very fullest record, as this would show that we were getting the broadest possible patent, and also that there was less chance of some prior art, overlooked by the examiner, cropping up later in the courts.

Even when you can secure broad claims, it is essential that your patent should also contain narrow claims, running all the way down to claims covering every nut, bolt and screw in the utmost detail. The reason for this is that if your patent ever gets into litigation, some of your broadest claims are certain to go by the board, and you should be prepared to contest the ground foot by foot as you retreat. Thus the succession of gradually narrowing claims exists for much the same reason as the succession of first-, second-, and third-line trenches in war.

Be sure that you have enough claims to cover adequately every phase of your invention, but beware of having too many claims. "Multiplicity of claims," as it is called, will irritate and antagonize the examiner, and if your patent ever gets into court, will cause the judge to interpret it most narrowly. But a basic patent, or one which represents a long forward step, is entitled to many more claims than a patent which covers merely some minor improvement.

Usually the claims of a patent application are rather tentatively drawn at first, in order to sound out the patent examiner and see what prior art he can discover. After the Patent Office has passed on it, your attorney will be in a position to redraw the claims, in view of the prior patents which the examiner has produced. Therefore, it would be most unfortunate to have an application allowed right off the bat. To guard against this, by insuring the receipt of at least one adverse office action, most patent lawyers intentionally make several serious misprints in the application.

A patent application, broadly speaking, consists in: (1) a complete disclosure of the invention, so that those skilled in the particular art will be able to duplicate it; and (2) claims as to what part of the disclosure the inventor wishes protected by the patent.

The oath asserts that you are the original and first inventor, and denies that the device was known, used, published or patented prior to your conception, or used or on sale in the

United States more than two years prior to your application, or patented abroad more than one year prior to your application.

The drawing is signed by the attorney. The petition and claims are signed by you. The oath is signed and sworn to by you. The filing fee is twenty dollars.

At any time from three to fifteen months (according to how far behind in its work is the division of the Patent Office to which your case happens to be assigned) you will receive an "office action" pointing out the misprints in your papers, and disallowing some of your claims for lack of utility, or for incompleteness, or for not being supported by the disclosure in your drawing and specifications, or for being "functional" (i.e. attempting to cover the need, or result or effect of

your device), or for not being an improvement over the "prior art," in which latter case certain earlier patents will be cited against you. The examiner may require you to divide your application, on the ground that it contains matters which should be handled by two separate branches of the Office. In rare cases, some of your claims may be allowed.

Within one year of the action, you must "amend," i.e., file a paper correcting the mistakes, and either changing your drawing, specification and claims to meet the objections of the examiner, or else arguing with him in an attempt to convince him that he is wrong.

There are three ways of getting around a citation: (1) amend your claim; (2) convince the examiner that the cited patent has no bearing on your invention; or (3) convince him that your invention is an improvement over the other.

If you get away with No. 2, you are clear of the other patent. If you get away with No. 3, your claim will be allowed, but will infringe the other patent, if it is still alive.

But note that, although the *claims* of an earlier patent are all that is material to the question of *infringement*, yet either the drawing, specification, or claims of that patent may decide the question of *anticipation*: i.e., whether the other fellow beat you to it.

I find that there is a persistent idea among technical men that, in order to get around a prior patent which is cited against you by the Patent Office, it is necessary to file some sort of paper agreeing to hold your patent subject to this prior patent, and that this is the signif-

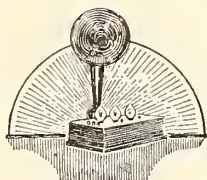

icance of the references to earlier patents, frequently found in printed specifications. But nothing could be further from the truth. This mention is usually either for the purpose of shortening your description, by referring the reader to some earlier step in the development of the art; or for the purpose of giving to a divisional application the benefit of the filing date of the parent case.

An application becomes abandoned, if the applicant fails to reply within one year after any office action; or becomes forfeited, if he fails to pay the final fee within six months after allowance. If not prevented by some other consideration, a new application can be filed in place of an abandoned one; and, if filed before abandonment is complete, can rely on the filing date of the original. A forfeited application can be renewed within two years after allowance.

Division of an application is affected by striking out the objected claims, and then embodying them in a new application.

If either the specification or claims of one application covers the same invention contained in either the specification or claims of another application, the Patent Office may ask either party to adopt certain claims of the other by amendment, and may then declare an interference, throw open the files of each party to the other, and require evidence as to which party is the first inventor. But before doing this, the Patent Office frequently requests of the junior party an informal statement as to the date of his conception, and if this date is not earlier than the filing-date of the senior party, no interference is declared.

The first step in an interference is the preliminary statement, the contents of which, and the relative value thereof, we discussed last month. If the preliminary statements do not prove sufficient, further evidence may be filed in their support, but no inventor will be allowed to claim any dates earlier than those of his statement, except for extraordinary reasons. The disputed claims are allowed to the party who proves first invention coupled with diligence in reduction to practice.

An interference is sometimes declared between a pending application and a patent issued not more than two years before the application was filed. The grounds are slightly different in this case, for only the *claims* of the

issued patent are considered. But, as a victory for the applicant will not result in cancelling the prior patent, and as the whole matter will have to be fought all over in the courts, it may be well for the applicant to avoid interference, and insist upon the issuance of his own patent, on *ex parte* proof that his conception was earlier than the other's filing date.

In handling a patent case, an almost unlimited amount of delay is possible. Thus you can wait nearly a year after each office action

before amending; and, in order to guard against premature allowance of your application, you can keep making intentional mistakes in every amendment. But note that an amendment which does not represent a bona fide attempt to meet the action of the examiner, or which merely reiterates an argument once rejected by

the examiner, will not prevent the case from becoming abandoned through one year's failure to respond to an office action.

The chief object of delay is to extend the date to which your patent will protect you: i.e., seventeen years from the date of issuance. The later your patent issues, the longer it will protect you. Thus, in the absence of other considerations, a reputable attorney will always delay as much as possible.

On the other hand, extreme speed may be desirable to secure immediate protection against infringement, or to put the patent in shape for a speedy sale or as the basis for foreign applications. You see, a foreign application should be filed within a year of your American application, and should be drawn in the light of all the information which you can possibly glean from the Patent Office as to the state of the prior art. Hence the rush.

But inventors are apt to be influenced by a very natural curiosity to learn as soon as possible how their case is going to turn out. And lawyers without an extensive clientele are apt to be influenced by a very natural desire to get their pay as soon as possible. Both of these tendencies should be guarded against.

If the examiner twice rejects a claim on the same grounds, the applicant can appeal to the examiners in chief by paying a \$10 fee. From them, a \$20 appeal lies to the Commissioner of Patents; and from him a \$15 appeal to the Court of Appeals of the District of Columbia. Printed records and arguments must usually be furnished on appeal.





Beware of "double patenting"! Two patents cannot be obtained by the same person for the same invention, nor can a broader and more basic patent be obtained by the holder of a more detailed or more advanced patent. In either such case, if the second patent inadvertently issues, it will be void. So it is imperative to draw your first application so as to cover everything that you will ever wish covered. Also you should be careful not to let some subsidiary later application issue before your basic one, although there are some court decisions which hold that this is allowable.

The rule against double patenting has even been extended, so that if two inventors in the same field assign their applications to the same assignee, and if a patent issues on the narrower and latest-filed application, then this patent will prevent the issuing of a patent on the broader application, although first filed. This is based upon the fact that two applications, owned by a common assignee, cannot be put into interference with each other, and upon the theory that the choice by the owner to let one of these patents issue first, is equivalent to an adjudication of priority in favor of the inventor of that patent.

When, by numerous amendments, your case has at last been put in condition for allowance, the final fee of \$20 must be paid within six months. Thereupon, on the fourth Tuesday after the Thursday after your fee was received, the patent will issue and will be published in the next *Official Gazette*.

An issued patent, from which has been inadvertently omitted some important claim covered by the disclosure, or whose disclosure

is insufficient to support its claims, may be surrendered at any time within two years of issue, and a petition for a "reissue" be filed, on which the procedure will be very similar to the procedure on an original application.

If an issued patent claims more than the inventor is entitled to, he can file a "disclaimer" of the excess. Personally, I never could see any particular point to disclaimers. True, if you sue a man for infringement, and he can show that your patent was too broad, then the judge will not award you your costs. But, even so, since the chief value of a patent is as a scare-crow, I should prefer to have my patents as broad as possible, and take a chance on losing my costs.

In the foregoing article we have covered not only Patent-Office procedure, but also some phases of Patent-Office tactics, which most inventors think should be left strictly to their attorney. Most attorneys think this too. But, don't you believe it! Unless the inventor thoroughly understands the tactics of his case, he will not be able to decide intelligently the questions which his attorney puts up to him, and may unjustly blame his attorney for carelessness, delay, etc., when these may happen to be exactly what the situation demands.



Napoleon once said that he owed his success to his knowledge of *tic tacs*. When asked if he did not mean "tactics," he said: "No". He ascribed his skill in getting out of difficulties to his practice of putting tick-tacks on the teachers' windows and then not getting caught. So, if some of the foregoing article savors more of tick-tacks than of tactics, I hope that the reader will excuse me.

---

### Wanted—Information on Railroad Radio

The Committee on Application of Radio to Moving Trains of the Association of Railway Electrical Engineers desires to communicate with any one who can give information regarding actual experiments in radio reception or transmission to or from a moving train.

Kindly communicate with the Chairman of the Committee,

Mr. P. S. Westcott,  
Assistant Car-Lighting Engineer,  
Chicago, Milwaukee & St. Paul Ry. Company,  
West Milwaukee Shops, Milwaukee, Wisconsin

# The Search for a Telephone as Sensitive as the Ear

By GEORGE B. CROUSE

Chief Engineer of the Connecticut Instrument Co.

**T**HE most important instrument in radio broadcast systems is older than the pyramids, as old as the race itself. This instrument is the human ear. To say that the ear is of first importance is not an exaggeration, for to you no improvement in a radio device would be of the slightest use or interest, were you not equipped with ears. It is of first importance to the engineer, because he can neither redesign it nor improve it; he must take it as he finds it, study its characteristics, and build all the rest of his apparatus to fit its needs.

Even aside from the interest which this organ holds for us as designers and users of radio, the marvelous ingenuity and delicacy of its construction, its accuracy and the wide range of its functions, make it one of the most fascinating organisms in nature. This article, therefore, has for its purpose the explanation of the construction of the ear and the discussion of some of the problems which its characteristics have placed before the designers of radio telephone systems.

Considering the functions which our auditory apparatus performs for us, it first of all detects the presence of sound vibrations in the air. Second, it determines the relative loudness of various sounds and to some extent the actual loudness of a single sound; we say sounds are loud or soft. Third, the ear distinguishes various kinds and qualities of sounds; it distinguishes and identifies the barking of a dog, the rattle of a carriage wheel on the street, the voices of our friends: the trained ear will distinguish the difference between two violins when played successively by the same man in the same way. Fourth, our two ears acting together detect roughly the direction from which a sound is proceeding, but since this is a function which is not of much interest to us in radio, we will not consider the mechanics of its performance.

Turning now to the devices which perform for us these functions, we will undertake the explanation by designing a model to perform in

a manner similar to the ear. In this model we shall combine elements and apparatus ordinarily used in radio telephones.

Historically, it is undoubtedly true that in the lower forms of life the auditory apparatus performs only two functions, those of detecting and roughly measuring the loudness of a sound. We are, therefore, justified in dividing our explanation in two parts and considering first only these two functions.

An apparatus for these purposes would logically take the form shown in Fig. 1 where we have a horn (1) to gather up and concentrate the sound waves at its small end, where they cause a diaphragm (2) to vibrate. On the centre of this diaphragm is placed a carbon microphone (3). This is the device ordinarily used in telephone transmitters and its function is to vary its resistance in unison with vibrations applied to it. We connect this microphone in circuit with a dry battery (4) and the primary winding (5) of a transformer. This transformer may be an audio-frequency transformer taken from a radio set. Now when the current in this primary winding varies, due to the variation in resistance of the microphone, it causes a proportional alternating current to flow in the secondary winding (6) and we measure this alternating current with the meter (7). Then we have a complete instrument for detecting the presence of a sound falling on the diaphragm and for measuring its loudness on the scale of the meter.

This sounds simple enough until we remember that for this apparatus to be the equal of the human ear, it must be capable of detecting a motion of the air of one thousandth of a millionth of an inch, while at the other extreme, it must not be overloaded by air motions ten thousand times as great.

In order to perform the third function of analysing and determining the character of a sound, our model will become much more complex and its explanation requires a short digression to consider the character of sound waves.

You remember in your class-room days, that



in the physics course, the principle of resonance was demonstrated by setting up a tuning fork (Fig. 2) which was not vibrating and bringing near it a second identical fork which was sounding. After a while the fork which originally was not vibrating was found to be in motion. This motion was set up by the energy of the sound waves proceeding from the second fork. If the two forks were not exactly alike, the motion would not be transferred from one to the other. The principle is the same as when a church bell or an old-fashioned swing is set in motion by applying small impulses at exactly the right time.

Now to set a tuning fork in vibration by means of sound waves falling on it, the sound must have exactly the same pitch as the pitch of the fork, but this sound need not be generated by another tuning fork. It may come from a piano string, the human voice, a pipe organ, or any other source. However, if we use say a piano string to set the fork vibrating, it will be found that the sound will set forks of several different pitches vibrating. On the other hand, if our source of sound is an open diapason organ pipe, only one size fork will be found to move. This is due to the fact that the sound of a piano is "compound" or made up of a number of simple sounds, whereas the sound of the open diapason organ pipes is pure. Practically all sounds are compound and their

number of them would be required. If while a sound acts on these forks, we observe which of them have been set in vibration and to what extent, we have an accurate knowledge of the character of the sound.

Now the ear employs just this principle. It contains a series of bodies which like the tuning forks are capable of vibrating at one pitch and one pitch only. The incoming sound acts on these bodies and sets the proper ones in vibration and the nerve terminals determine the amount of the motion.

Before we proceed to build this principle into our model, however, we must examine the properties of the ear a little more closely. When one actually tries the experiment with the tuning forks it is apparent that a certain length of time is required to set the fork in vibration by resonance and that the motion when once set up persists for some time after the cessation of the sound which caused it. Now we know that in the ear, the response and analysis is almost instantaneous and that a sound ceases to be heard very quickly after the sound itself has ceased. If this were not so we would be totally unable to follow a fast conversation or a rapidly executed piece of music: the syllables and notes would run into each other and become confused.

For this reason we must find some way of causing the sound to affect the forks quickly

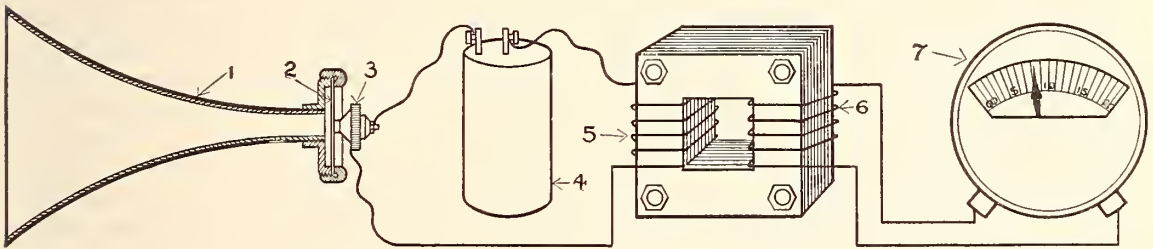

FIG. 1

Apparatus for detecting and roughly measuring the loudness of a sound

character is determined by the number and relative loudness of the various simple sounds which they contain.

Therefore, if we wish to determine the character of a sound we have to analyze it and determine the pitch and relative loudness of the various simple sounds which it may contain. For this purpose, we might use a battery of tuning forks, upon which the sound to be analyzed is allowed to fall. Each of these forks would differ from the other in pitch and a great num-

ber of quickly stopping their motion after the sound has ceased. The way in which this is accomplished in the human ear and the best way for us to accomplish it in our model, is to immerse the forks in liquid instead of air. The greater weight of the liquid will be more effective in moving the forks and the viscosity of the liquid will be effective in stopping or "damping" their motion after the sound has ceased.

Our complete apparatus will then take the form shown in Fig. 3 where as before we have a

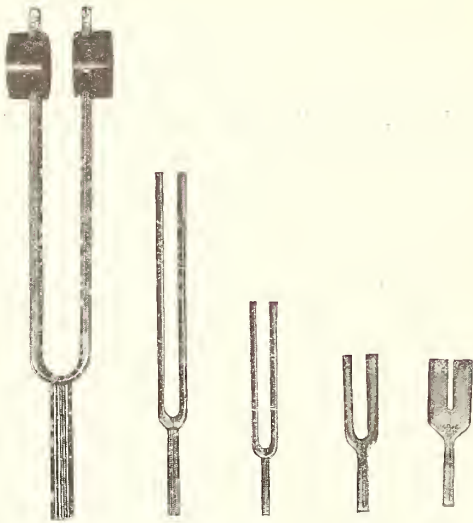

FIG. 2

The vibrations of one tuning-fork will not cause a second fork to vibrate, and thus produce a musical sound, unless both have the same vibration rate. However, the sounds produced by a piano string, the human voice, or a pipe organ, for example, may cause vibrations in more than one of the forks, since such sounds are made up of many simple tones, some of them being the same as those of the tuning-forks

horn (1) which gathers up and concentrates the sound waves at the small end, where they cause the diaphragm (2) to vibrate in unison. The motion of this diaphragm will then have to be transferred to a liquid since the liquid will be very much heavier and harder to move than the air, we must employ a leverage between the diaphragm and the liquid. This leverage we have shown as a simple lever (3) attached at one end to the diaphragm (2), pivoted at the point (4), and attached at the other end to a second diaphragm (5) which encloses the liquid in the chamber (6). Since liquids are practically incompressible, we must employ a third diaphragm (7) at the other end of the chamber so that the liquid can move freely. In the liquid chamber (6) we place a large number of tuning forks, each of a different pitch and attach to each of these forks a carbon microphone (8-8 etc.), each with its electrical connections to a battery, transformer and meter.

Then the sound entering the large end of the horn is concentrated at the small end and causes the diaphragm (2) to vibrate. The motion is then transferred by the lever (3) to the second diaphragm (5) and thence to the liquid in the chamber (6). Movement of the liquid causes

the forks corresponding to the various simple components of the sound to vibrate in proportion to the strength of the components. This motion of the forks affects the attached microphones and thus indicates on the meters (9-9, etc.) We thus have a complete apparatus for detecting the presence of a sound, determining its loudness and analyzing it into its components and thus determining its character. We have shown only five forks in the model but it must be understood that it would be necessary to have many thousands of them. The lowest fork would have a pitch corresponding to about 32 vibrations per second and the highest from 30,000 to 40,000 per second.

The human ear is constructed in principle almost exactly like our model as will be seen from Fig. 4. In this figure we have the external ear (1) corresponding to the horn for gathering up the sound and concentrating it on the diaphragm or drumskin (2). The leverage between the drumskin and the second diaphragm in the liquid chamber is obtained by a system of three bones (3) named from their appearance, the hammer, the anvil and the stirrup. This particular form of lever is employed to prevent any unusual shock from injuring the delicate apparatus of the inner ear, since these bones are arranged so that they slip over each other at their joints if too great a motion is imparted to them. The liquid chamber is shown at (6). It consists of a bony case shaped like a snail shell and named from its appearance the Cochlea. The end of the lever system is attached to the second diaphragm known as the Oval Window (4). The third diaphragm for the purpose of allowing freedom of motion of the liquid shown at (5) is known as the Round Window. In the liquid chamber or Cochlea (6) are located the thousands of vibrating bodies of various shapes and sizes which take the place of the tuning forks in our model. The microphones of the model are replaced by nerve terminals attached to each of the vibrating bodies, each terminal being connected to the brain or measuring instrument by its own nerve fibre.

This short description cannot do justice to the wonderful refinement and ingenuity displayed in the design of our ears, and the action of some of the mechanism is still imperfectly understood. We know very little about the construction of the vibrating bodies, particularly those which are employed to respond to the lowest frequencies. These vibrators are so



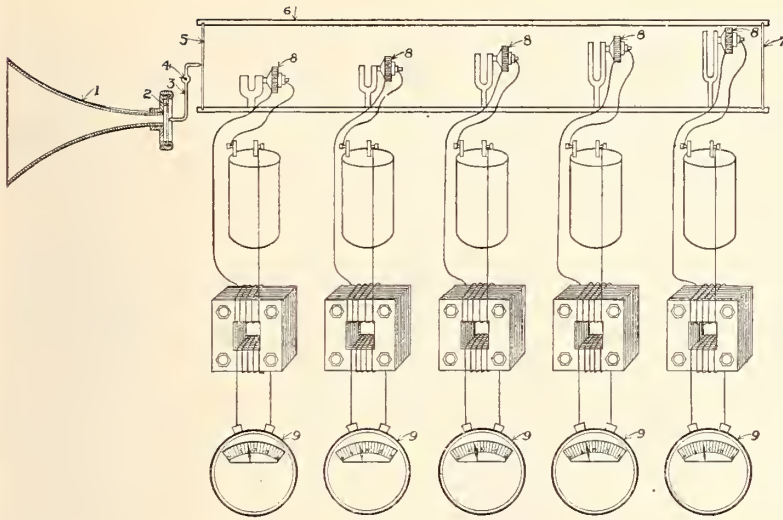

FIG. 3

Vibrations are readily started and quickly "damped" when the tuning-forks are immersed in liquid. This indicates an apparatus for detecting the presence of a sound, and determining its loudness and character. The human ear is constructed in principle in a similar way

small that they are not visible to the naked eye, as indeed they must be to be crowded into the small space available. That they do vibrate at one pitch and at one pitch only we know. Neither have we the space to describe the apparatus for equalizing the pressure on both sides of the drumskin, nor the means for tuning the drum, nor a host of other devices which go to make up the complete organism.

This description is sufficient, however, for us to gain a clear idea of the capabilities and limitations of the ear which must be taken into account in the design of radio and acoustical apparatus.

The most significant factor in the construction of the ear is the completeness of the analyzing apparatus. We should expect that the question of distortion in radio telephones would be a very serious one, for the ear is not easily fooled. This subject of distortion has been completely covered in a previous article\* in which we pointed out most of the things which a radio telephone must do to please the ear. We shall, therefore, confine

\*"How Your Telephones Work," RADIO BROADCAST for January, 1923.

ourselves here to those things which the system must *not* do.

From this point of view, the extreme small size of the parts of the ear is significant as will be seen from Fig. 4 and as though Nature had not gone far enough in this direction to astonish us, she tucked into the corners the apparatus by which we balance ourselves on two feet. The smallness of the fibre which connect the vibrators with the brain is even more extraordinary. Some idea of their size may be gained from the fact that the entire cable, containing thousands of nerves, is less than  $\frac{1}{10}$  inch in diameter.

From this we are at once led to suspect that one of the weak points in the design of the ear is liability to fatigue and particularly to fatigue from the sounding of a single note. The case is very much as though, in our model, we made the wires connecting the microphones with the measuring instruments very small so that if they were used very long at a time they would heat and increase their resistance. In the case of the auditory nerves exactly this happens, with the additional psychological factor that when a nerve is fatigued, we become nervous and exasperated.

This point is readily proved from your own experience. Almost everybody has at some time in his or her life been irritated to the point of exasperation by children's voices and this

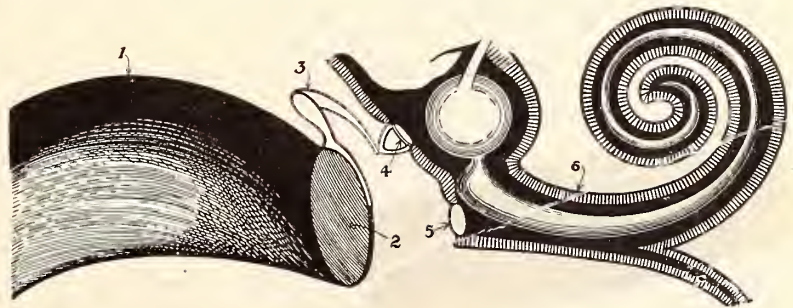

FIG. 4

The mechanism of the human ear. (1) External ear; (2) drumskin; (3) leverage apparatus: "hammer," "anvil," and "stirrup"; (4) Oval Window; (5) Round Window; (6) Cochlea

does not arise from any lack of sympathy with children. It is due to the fact that children have not yet learned the knack of tonal modulation, so that they talk at almost a constant pitch and this is more particularly true when they are excited or interested in their play. The result is that the voice sounds in all directions reach the brain of the listener over a very small number of nerve fibres which soon become exhausted.

It is true that not all monotonous sounds are irritating, but the reasons for this lie in the brain rather than in the ear. The brain has the power under certain circumstances to shut off most of the current to a given set of nerve fibres, so that they are not fatigued although excited for long periods. This control exists, however, only when the sound which is shut off is different in character or pitch from the sounds to which we are trained to direct attention. For instance, we can easily shut out the noise of the wheels on the rails when riding in a railway carriage. On the other hand we are trained from infancy to pay attention to the sound of human voices and therefore we find it most difficult to shut out the annoying voices of children at play.

It is also very difficult for the brain to shut out sounds that are similar to other sounds which it wishes to hear. Have you ever watched a piano tuner search all over the room for the object which insists on vibrating in resonance with a certain string on the piano? The reason is that he wishes to listen to the sounds of the piano and he, therefore, finds it impossible to shut out the other similar sound.

A further simple experiment to prove this point is to have someone play any selection on the piano and while this is in progress tap a single key of the piano lightly and continuously. It will be impossible to direct the attention away from this insistent note and it will generally be found that the result is so annoying to everyone within hearing that the experimenter will be forced to discontinue his work "under pressure of public opinion."

A long series of tests and experiments along the above line, some of them simple, others of a more technical nature, have convinced the writer and his associates that this liability to local fatigue is one of the most important characteristics of the ear from the viewpoint of the designer of acoustical apparatus. This con-

clusion has a particularly important bearing on the design of the acoustical elements of a radio telephone system. On the ordinary telephone, we never listen for very long at a time, even though it may seem an eternity when waiting to use a party line, whereas in radio broadcasting we may listen continuously for hours. For an illustration of the way in which this knowledge of the characteristics of the ear should be applied in the radio art, we turn naturally to our own products, telephone receivers and loud speakers, since we speak there with the greatest authority. When radio broadcasting first came into popularity, the only telephone units available for its reception were those which had been used for land line telephone and wireless telegraphy. Now practically all of these telephones employed a magnetic system which varied the pull on an iron diaphragm in accordance with the incoming signal. We

tested a great number of diaphragms of iron and other metals and found that all of them had very definite natural periods. In other words, they could be and were forced by the magnetic system to vibrate at the proper pitches. However, when so vibrating, they also vibrated at their own natural pitch which never changed. Here we have the ideal condition for fatigue of the ear.

The problem was then to devise a telephone diaphragm which was "dead", or in other words, which would not vibrate freely by itself. This problem was not an easy one, for it was found very early that all of the metallic materials had strong natural periods which could not be completely killed without greatly reducing the sensitivity of the phone. However, after experimenting with a great variety of substances, a non-metallic diaphragm material was found which satisfied the requirements. Receivers constructed of this material have no single-pitch clamor. A large number of them have been placed in use and where we have been able to obtain the opinions of the users, they are unanimous that these instruments may be used continuously without annoyance. Results in actual service by a large number of users are the final check of any theory. We believe, therefore, that we have proved the importance of the study of the ear and have justified the statement that the ear is the most important of radio instruments.

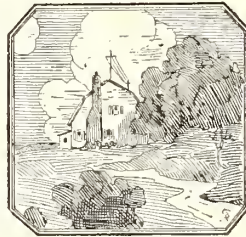



# Concerts for All in a Veterans' Hospital

By J. TOWNSEND BRADLEY

WHO would have thought that the very operators that pounded the keys off Belle Island north to the White Sea, during the War, would be some day turning on a set as easily as a phonograph and getting the best of music and entertainment, leaning back in an easy chair and just listening, without the dreaded "Dangerous Area" reports or without fear of missing his call? What the few lines that follow have to do with, is the percentage of Navy and Army men that didn't quite get through and who have been in Government Hospitals for the last few years. To be specific, this article concerns the U. S. Veterans Hospital No. 50, which along with its Commanding Officer, is well known and a favorite indeed with the Veterans.

The majority of the men here at Prescott, Arizona, do not know much about radio, but there are about forty loyal radio fans and among them a liberal sprinkling of Army and Navy operators. The entire group are ardent fans and aside from the study they are making of radio, they furnish quite a lot of amusement to their bunkies. Nearly every ward has a radio set and in some wards two may be found. The result is that the heretofore long evenings are now passed enjoyably with the programs of KHJ, KF1, and KPO as well as many other stations.

The receivers used vary from a small one-tube set to the elaborate five-tube variety. The majority are home-made, but quite a number of the men prefer to buy them ready made. The general practice here is to use head phones because loud speakers require quite a volume to operate satisfactorily and then are likely to wake up some patient, which means in many instances that his whole night's sleep is disturbed. The ear phones are generally connected to a double lamp cord that runs along the moulding and down to the receiver. Thus in case a patient does not care to leave his bed and go down to his buddy's radio, all he has to do is to lean over and put his phones on, and in comes the music.

Wards 2, 10, 11 and 14 are so connected. The Ward 14 radio set is the largest, using a Kennedy Type 101 receiver with a Type 525 Audio Amplifier and a Wireless Specialty Shop two-stage radio-frequency attachment. The antenna and ground are brought to one plug which can be used in such a way as to use the radio-frequency amplifiers or not. The same connection is used for the loop, which has a small variable condenser to tune it, in addition to the regular clips.

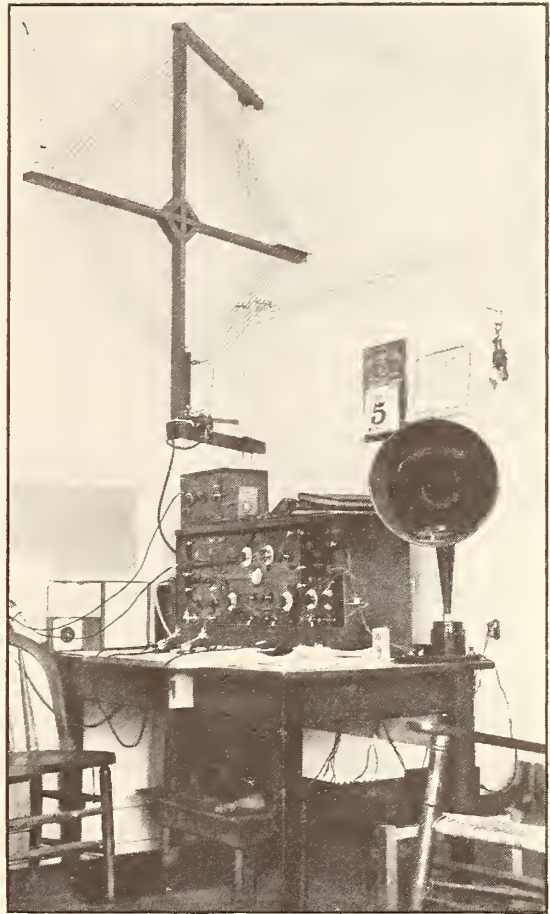

THE 5-TUBE RECEIVER IN WARD 14

The veterans at the Prescott, Arizona, hospital enjoy concerts from stations 1500 miles away, using the loop antenna shown in the picture

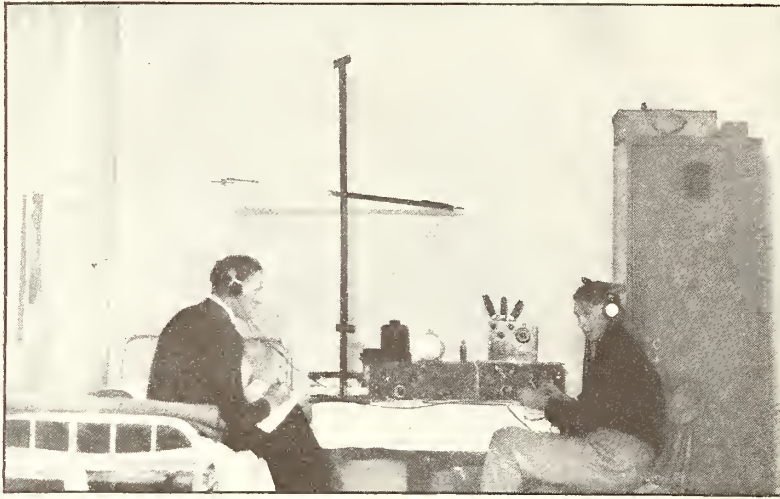

TUNING-IN WITH "HOME-MADE STUFF"

V. S. Keggs and G. B. Gilchrist listening to a station on the west coast. Head phones are generally used in the wards so that the sets may be operated without disturbing one's neighbors, especially during the evening hours

Those of you who have not worked with radio in this part of the country do not know what we have to contend with. The power lines cause a great deal of interference and reception is usually done only during the night. The big set will bring in the signals fairly well, especially on cloudy or rainy days. We always can get arc and spark and as several of the men are ex-Army and Navy operators, they copy it down for practice. If it's press, it is hung up for everyone to see.

On nights when the static comes roaring in we connect our loop and a few stages of radio-frequency, and manage to do remarkably good

than the one at Phoenix, Arizona, is about four hundred miles away, while San Francisco and Portland stations are at a much greater distance but still come in so loud that the windows quiver. Our favorite stations are KHJ, KF1, KPO, and the Kansas City *Star's* Night Hawks.

Aside from amusing the gang and their visitors, and members of the Staff at this hospital, the station is used to test out the home-made sets and to try out numerous ideas that some of the men have put into practice. The place is nearly always full of sets and parts to be tried out.

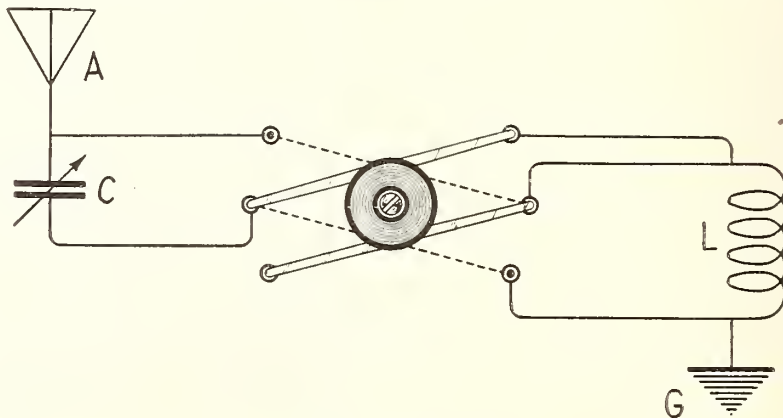

HERE'S AN IDEA

A Marion, Ohio, reader sends us the accompanying diagram with the remark: "Why use eight switch points with a series-parallel switch when six will do and simplify the wiring?"



# Adventures on an American Yacht in Mexico

A Few Intimate Glimpses of Actual Happenings in the Life of a Commerical Radio Operator. Here We Find the Reason for so Many Young Men Entering Radio as a Career

BY A. HENRY

Going to sea is what radio operating usually means, and true stories of life, as an operator finds it, are usually a bit salty. The author of this article has operated afloat and ashore. He is, as we say in radio, an "old timer" and whether you sailed the seven seas when he did, or expect to sail, or are sailing, or never expect to leave your home town—life as it is lived aboard ship should be interesting to you.

This is the fourth of a series of true stories from the life of a commercial operator. Next month, Mr. Henry will tell about his trip around the West Indies on the Duke of Sutherland's yacht, the S. Y. *Cantania*.  
—THE EDITOR.

**A** LONG toward the middle of April I was standing with a group of operators in the "static room" at 29 Cliff Street, New York, swapping stories and waiting for something to happen. Now and again the buzzer up on the wall would bark out the signals that spelled an operator's name. He would enter the superintendent's holy of holies to be commended, transferred or fired, and then return to our group.

For some reason or other I hated that buzzer—it always filled me with unpleasant forebodings and each time it spoke, its menace was removed only when I recognized the first two or three letters of a name not my own. I had been in the static room for periods of an hour or two on the sailing and arrival days for three successive trips now, and I had not been called. Just as I was beginning to think that my fears were unfounded and feel almost as much at home as some of the older members of the operating profession—the passengers and crew of a coastwise liner—when I heard my last name squawking from the buzzer and recognized the smooth swing of the "Super," who had formerly been an operator.

Before his desk I felt like a culprit for no other reason than foolish fear. There was nothing I could think of to be worried about

but I couldn't help feeling that there was something in the wind. Without so much as looking up he asked me if I knew how to install, operate and keep in repair a 2-KW synchronous transmitter and type E tuner. That took my breath away but I gaspingly said something about being able to do it if I could look one over for a few days. Although I had never actually seen one I had read up on it quite a



S. Y. "WAKIVA 1"

Anchored in the Panuco River, a few miles below Tampico. Steam was always up and the yacht kept in readiness to weigh anchor at a moment's notice

little and felt that it was but necessary to reduce my book knowledge to practice.

"All right," quoth this lord high executioner, "you have free rein in the school and in the repair department and a week to learn all you can. Then I'm going to send you out to do the job on a yacht and I feel that you will do it properly. Will you?"

As you may guess, I assured him that I

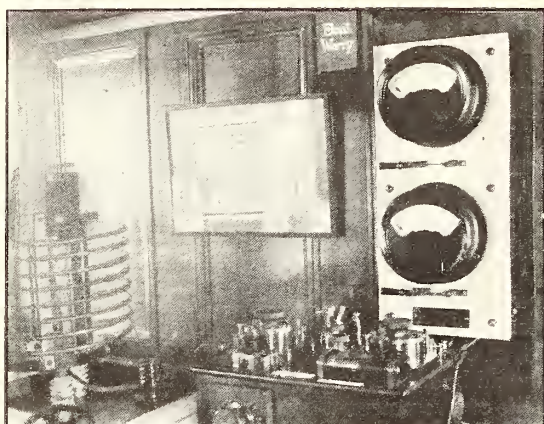

THE NEW RADIO ROOM WAS FINISHED AT LAST

And I transferred the 2 K. W. outfit to its new home. There was hardly room to get the camera in when the job was done

would. For the moment, I forgot that I had recently fallen in love with a young lady in Jacksonville and did not want to leave my present job, but there was no backing down and the mails would have to be relied upon temporarily.

So I spent a week in the school and managed to make a general nuisance of myself by asking the mechanics too many questions of a technical nature which they dodged by becoming angry. Upon the completion of my training I was presented with a wavemeter, which in those days was a rare instrument, and received an assignment as junior operator on a ship bound for Nassau and Tampico. The yacht to which I was assigned was in Tampico and the plan was for me to work my way down and for the operator there to work his way back.

After a voyage during which there was only one short period of excitement we arrived in Tampico. The excitement occurred some time between one and six one hot morning after we had rounded Tortugas and were in the Gulf of Mexico. The radio room was of more ample proportions than most and it was much easier to stand night watches in a steamer chair, one of which was easily obtained from the deck. On the particular night in question I had procured the chair and had made it more comfortable by the addition of a pillow from my bunk. I had locked the wooden screen of the radio shack on the inside, making it impossible for any one to get in the window. Then I closed the door and poked the front end of my chair against it to keep it closed as there was no lock. During the night I fell asleep and was

rather rudely awakened by having my chair pushed along the floor as someone opened the door. There was no getting out of it: the Captain himself caught me red-handed, asleep on watch. He delivered a lecture to which I listened very attentively—and when he departed my repose was continued.

In Tampico I was rather surprised to find that we were docked along a great wharf with several other vessels of goodly size. It was not my idea of Mexico at all. I had expected to find a few adobe huts and a group of Mexicans stealing each other's horses and scrapping over a beautiful señorita. Tampico, in many respects, looked like innumerable other small cities.

After several trips to and from the yacht, which was anchored some three miles down the river, my things were transferred and the other operator and I changed abodes. My new room was a dream. As there were no guests aboard, the officers were using the guests' quarters and my room, which adjoined the captain's, was a great deal more sumptuous than any of those I had occupied on previous assignments, and when I forgot about my huge salary of thirty-five dollars a month (I had been raised five, on accepting this foreign assignment) you may be sure I felt very much of a lord.

There was a complete crew aboard and I was surprised to learn that steam was always up and the yacht kept in readiness to weigh anchor and depart at a moment's notice.

Let me digress for a moment and tell you why the yacht was in Mexico. A certain oil company had holdings outside Tampico and maintained its offices in the city. At the time we are considering, just about ten years ago, there was quite a turmoil under way in dear old Mexico, and Americans were looked upon with anything but favor. American oil tank steamers, taking on cargoes at Tampico, could make it easy for those operating the loading station if they reported their approach by radio. This was particularly true in view of the unreliable operation of the telegraph lines. The Mexicans would not hear of the establishment of a radio station at the loading point so the yacht was sent down and anchored a few feet from shore. A telephone line was run out to her and the whole arrangement was at least as good as a land station would have been, from an operating standpoint.

In addition, two swift motor boats were provided to carry the employees from the city



to the yacht in case of emergency. For a time the emergency seemed imminent. The United States appreciated the situation as evidenced by the battleship *Connecticut* that rode at anchor off the bar just beyond the mouth of the Panuco River.

Part of my duty was the checking up of incoming oil steamers and advising the local agent, whose office was only a short distance from the point where we swung listlessly amid the muddy water that swished along our side as it passed out to sea. Time and again the American Consul at Tampico would call me on the phone and request me to relay a message to the *Connecticut*. Unfortunately, my end of the conversation could not be kept secret from some Mexican carpenters engaged in building a new radio cabin into which I was one day to transfer the installation. These gentlemen were of rebel tendencies and, though we never gave much attention to them, we wouldn't have trusted them with a plugged nickel.

Now and again "bum-boat" men would come down the river with the tide and offer us all manner of tropical delicacies such as mangoes, plantains, pineapples, alligator pears and limes. As a rule they were permitted aboard and their smiles and bows and "Si señor's" and "mañanas" all aided them in removing the shekels from our jeans without resistance. They were not the blood curdling variety of Mexicans at all.

Except for having to sleep under a mosquito bar to prevent being eaten alive, I was pretty well satisfied and managed to become very friendly with most of the crew. My association with one of the sailors and a mess-boy peevd the captain more than a little and soon won his whole-souled ill-favor. Among other things, he arranged to have me eat at the second sitting in the mess hall, which was for the quartermasters, cooks, second cooks, mess boys, etc. Of course I put up a howl but it availed me nothing.

In the meantime, I had become quite friendly with four English fellows who operated the radio outfits on English vessels plying

between Tampico and Galveston and Port Arthur. One of them agreed to purchase some itch powder for me; which he did. One day I was seated in my room with the door into the hallway wide open. The mess boy, with whom I had become friendly and for whose friendship I had suffered humiliation, was also the attendant who took care of the captain's room and my own. As I sat there drawing, he came in with my laundry and put it all away for me. The captain's bundle, he had dropped in the hallway as he came by. With a wink I asked him if he could not find something to occupy him on deck for a half hour. He agreed and departed. The captain's laundry was moved into my room and the door closed. It was then unpacked one piece at a time and given a treatment of itch powder and just as neatly re-packed and replaced in the hallway. Need I describe the captain's misery for the next two weeks?

Inasmuch as it was necessary for a certain number of us to be on board at night, the liberty launch would take one bunch one night and another the next. As a rule I was satisfied to stay aboard but did like to take the ride up with the gang and come back to the yacht to copy press from Sayville or Key West or Arlington. Then I'd go back when the launch did and help round up the drunkards. Even the fellows who had no use for me when they were sober were quite friendly after a few shots of *cerveza*, the Mexican for beer, and they came down to the dock with me in fine style.

There is one such rounding up expedition that will linger long in my memory. The fellows



A FOURTH O' JULY LIBERTY PARTY

had been paid and were out to paint the town red. We pulled in as usual—the boatswain and I—at the little dock some two blocks from the plaza which was in the center of the town. Just one block from our dock was a ramshackle *cantina* for which the fellows steered when they began to think of returning home. Here we would round up most of them, put them in the launch and go back for the rest. They would content themselves in hilarious manner or in slumber according to their particular bent until we returned. As a rule the sober ones would join our scouting party. On the night I have in mind, we rounded up all but one and were about to return to the boat without him when, on a corner a block away, I heard him wrangling with a Mexican policeman. From the names the officer was being called I knew that our wandering boy had been indulging in stronger spirits than *cerveza*. I arrived, after a sprint, just in time to prevent the cop's lantern from being kicked across the street. The cop proved a decent sort and smiled as I persuaded the quartermaster to come along with me. By the time we had staggered to the *cantina* on the corner, the others had all returned to the launch and were shouting for us to hurry.

Now and then one of the partly sober fellows in the launch would address a yell to my charge which the latter would return in kind, accentuating the reply with a wild hat waving and gesticulation. He refused point-blank to pass

the *cantina* without “jush one lil drink, Shpark, jush one more lil drink.” So I let go of him and in he went, while I yelled to those in the launch to wait for us.

I went into the *cantina*. Two Mexicans were seated opposite each other at a small table, their sombrero rims touching each other and two glasses of some sort of liquor before them. They were evidently engrossed in the discussion of some weighty problem. Before I could get around the tables that intervened, the quartermaster had poked his face up between the two, knocking off their hats as he did so. He looked at one, then the other, reached for their glasses and turned them upside down on the table. I expected gun play, but there seemed to be no guns. Instead, there was one of those sudden tropical rains—of glassware. I slid into a corner and turned a table over on top of myself. The few minutes I was there seemed like a life-time and just as the free-for-all was about to end, the crowd from the launch, attracted by the row, put in their appearance, the half-drunken ones yelling like fiends. Again the fray was on. Then I heard wild blasts from a police whistle and four policemen raced in, lanterns and all. In a jiffy the lanterns had been whisked from them and were behaving like comets with a jag on as they were thrown back and forth. One of them exploded behind the bar and covered a Mexican with burning oil. In his fright he ran around like a wild man and finally went out with most of the others racing

after him. That ended the scrap. The heads in our party were bleeding as we made our way back to the yacht, arriving some three hours late.

After two month's carpentry work on a six-by-six radio shack that could have been built in this country in a week, the palace into which I was to move the radio set was completed. Before the set was installed, the captain had a trap door cut in the floor which opened into the centre of the library below.

“You never can tell when you may need it,” he explained. “These ‘spigs’ are not much afraid of the American flag that flies from our stern.”

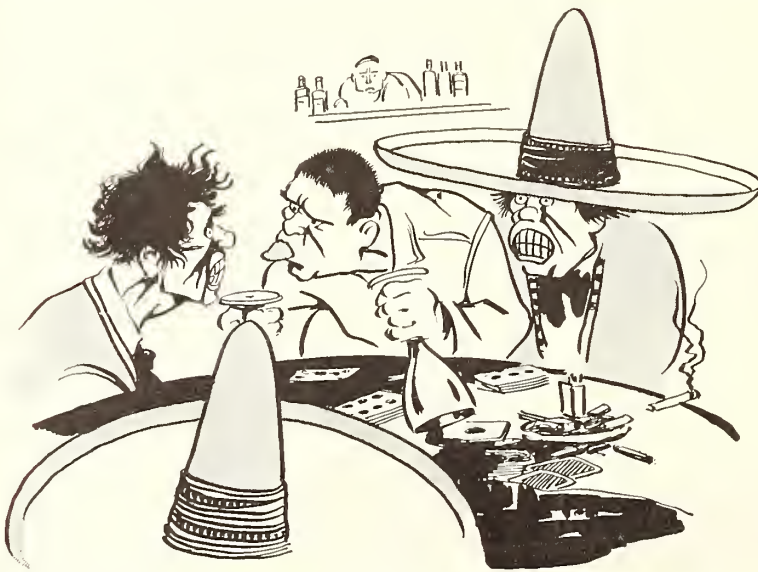

“I EXPECTED GUN PLAY, BUT THERE SEEMED TO BE NO GUNS”



The trap door took another two days, two of the sailors doing the job. It was made with springs and a spring lock. We had a bully time throwing the latch and dropping through to the deck below, for practice.

Finally I transferred the radio outfit and spent the better part of three days getting it tuned up. Then as the oil tankers would arrive or depart I would carry on tests with them and got the outfit working in fine style. By making certain changes in the antenna, it was possible to improve both the receiving and transmitting range. I could count on the old type E tuner and carborundum detector to pull in press from Arlington nearly every night. That meant late working and there were many nights, especially when it was very warm, that I'd fall into the bunk they had built in the room, read a few chapters of some book, and go to sleep.

On one such night I was almost asleep when a commotion on deck startled me. There was a shuffling of feet and I was about to go out and see what it was all about, when the mess boy yelled: "Sparks! Sparks! For God's sake, beat it! Two 'spigs'—" I waited for no more, but dropped through the trap door, slamming it shut as I went through. Then I raced along the lower deck and down to the engine room. As I went, I pulled off my outside shirt and smeared my face with grease grabbed from some of the running gear. The chief engineer happened to be in the engine room and I told him what the trouble was. "Here," he said, as he passed a pair of begrimed overalls to me, "jump into these and be an engineer for a while. I'll go and help Andy get rid of the 'spigs'." (Andy was the mess-boy). As he raced up on deck, I thought of a post card received from my dad a few days before, bearing the cheering message, "Don't Worry." I struggled into the overalls, smeared myself with more grease and went up to the scene of the melée.

By the time I got there the Mexicans were outnumbered and were jabbering in three parts Mexican and one English about wanting only to kill the "telegraphista" who they said was giving information of their activities to overcome the existing ruler of the land. When I appeared they paid no more attention to me than any of the others. Eventually they were calmed down, assured that we bore them no

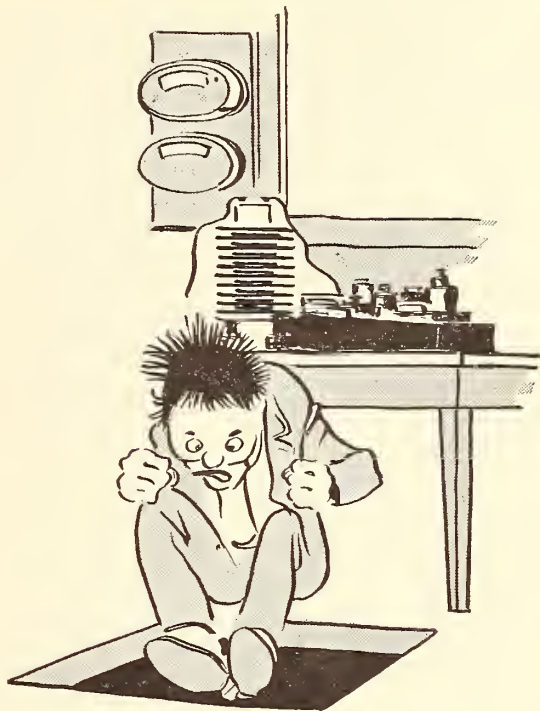

"I DROPPED THROUGH THE TRAP DOOR"

malice and were lowered into their boat. Then they drifted away with the tide and were soon nothing but a dark spot on the silver-crested Panuco.

Perhaps the firemen and sailors were treated to an even greater surprise than I, for the first mate, a huge down-easter who could not talk without swearing and boasting of his acts of prowess in the good old sailing-ship days, was awakened by the row on deck. As he rushed past the galley to gather his clan from the fo'c's'le the night watchman yelled something about being attacked by Mexicans. As the mate reached the fo'c's'le companionway, he saw a movement in the trees along the shore, became frightened, made for the saluting cannon and shot it off.

The cannon was on the deck just above the crew's sleeping quarters and some of them rushed up in time to prevent the mate shooting away any more of the forward canopy and rail in an attempt to scare off shadows caused by the moonlight among the trees. A very pleasant time was had by all.

# Choosing Your Regenerative Circuit

The Advantages and Disadvantages of the Single Circuit and Three-Circuit Regenerative Receivers

By PAUL F. GODLEY

FOR some time, RADIO BROADCAST has told its readers of the shortcomings of the popular single-circuit regenerative receiver. In doing so, it has not lost sight of the advantages of such outfits. The belief exists very strongly in many quarters, and there seems to be a great deal of logic behind it, that the benefits of this type of receiver are outweighed by its disadvantages. Many arguments for and against it have been advanced and one dissertation in particular, under the name of a man who should know better, is full of misleading statements, based upon a theory he would like to have the public believe.

Paul F. Godley, the author of this article, is vouched for by all who know him. His remarks concerning the two types of regenerative receivers are clearly put and to the point. If the exponents of the single-circuit receiver can produce as sound a case, we should like to publish it.—THE EDITOR.

WHAT type of regenerative receivers shall I build or buy?" is a question which is asked again and again. It seems that many of those who have had experience are unable to answer this question satisfactorily even for themselves. The intent of this discussion may best be expressed by the belief that an understanding of the simple action of a regenerative receiver will enable any one to clear up the question for himself.

In general, there are two classes of regenerative receivers, and their exponents claim certain advantages for each. They

are known as: single-circuit regenerative receivers (Fig. 1), and three-circuit regenerative receivers (Fig. 2). Both have marked advantages over many other methods of reception.

Because of its simplicity, the larger manufacturers have chosen the single-circuit receiver for their sales campaigns. By utilizing this simplest type, the greatest number of people may be brought to the use of radio in the shortest time. It is interesting to note in this connection that in England, due to a quite general use of the single-circuit type, laws designed to prevent the use of *all* types of regenerative receivers, have been enacted.

In the opinion of the writer, the British law is as far fetched as, perhaps, ours is lax.

The three-circuit regenerative receiver is manufactured at the present time by several of the smaller companies who have consistently clung to this type because of its marked selectivity and sensitivity, in the belief that the gradual education of the public to what is best will eventually lead to a preponderance in number of the three-circuit receiver.

The essential difference between the two types

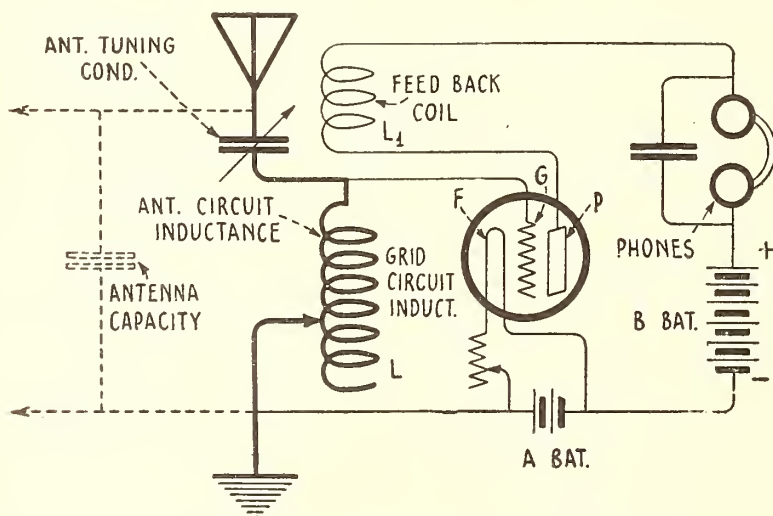

FIG. 1

A typical single-circuit arrangement, with the tube connected directly to the antenna circuit



may be gathered by comparison of Figs. 1 and 2. It will be noted that in the circuit of Fig. 1, the vacuum tube is coupled directly to the antenna circuit, while in Fig. 2, the vacuum-tube circuits are coupled to the antenna circuit through interlinkage of the magnetic fields of the two coils, L and L<sup>1</sup>. In the single-circuit receiver the coupling between the vacuum-tube circuits and the antenna is 100%, in the three-circuit receiver that value of coupling which works out to greatest advantage, both with regard to sensitivity and selectivity, is usually of the order of 1%.

Notwithstanding the size of the United States, considerable annoyance is caused by the energy radiated from regenerative receivers. They actually may be so adjusted as to operate as transmitters. And while all types of regenerative receivers may give rise to interfering energy radiation (unless direct steps have been taken to prevent this) the use of regenerative receivers in which the vacuum-tube circuits are very loosely coupled to the antenna would go so far toward the abatement of this annoyance that the question would never in seriousness be raised as to whether or not we, in this country, should legislate against these "transmitting receivers."

WHY AN OSCILLATING RECEIVER TRANSMITS

**B**UT," you ask, "how does this transmission by a receiver come about?" Also, "If a smaller amount of energy is transferred from the generating circuits to the antenna, would not the same smaller amount of energy be transferred from the antenna to the generating circuits in the case of an incoming signal?" In the answer to these questions lies an understanding of the regenerative principle. Those who would choose intelligently between receivers of various types would do well to study this simple action.

The telephone has been with us now for so many years that it has become a household

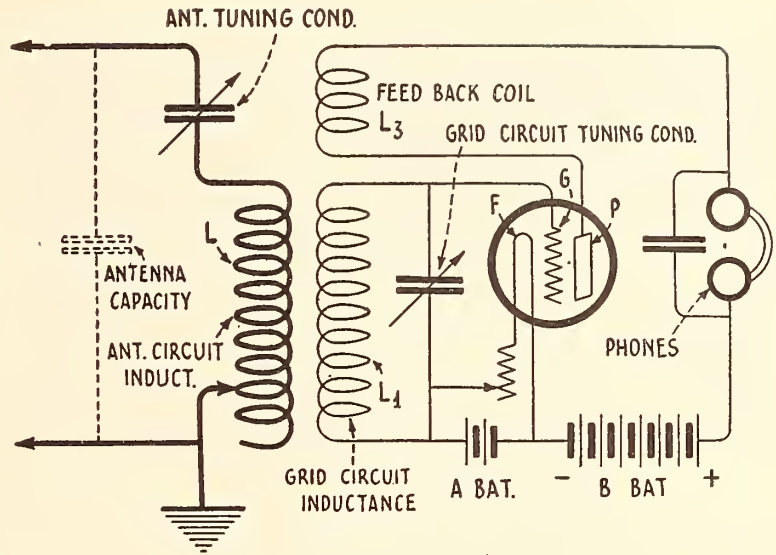

FIG. 2

The three-circuit arrangement. The principal point of difference between this and the hook-up shown in Fig. 1 is that the vacuum-tube circuits are inductively, not conductively, coupled to the antenna circuit

commonplace. Scarcely is there a person who has not endeavored to play the practical joke which may be perpetrated by placing the telephone receiver against the telephone mouthpiece. When this is done, a loud squawking or squealing results, to the great discomfiture of the "party" on the other end. The "squawking" arises due to regeneration—to a "feed-back" of energy as follows: when the receiver, Fig. 3, is placed against the mouthpiece, the slight jarring of the mouthpiece disturbs the carbon granules of the microphone behind it; disturbance of the granules changes the resistance of the microphone, which results in a change of the flow of current through it; the changed current brings about a change of the magnetic lines of force which permeate the induction coil; the sudden rise and fall of the magnetic lines of force create within the secondary winding of the induction coil, a fluctuating current which energizes both the telephone line wire and the telephone receiver. If this cycle of changes took place but once, there would be heard in the telephone receiver one very short click. But, so long as the receiver is held to the microphone, the cycle of changes occurs over and over again. The click in the receiver serves to disturb the granules in the microphone a second time, and so on and on. The rate at which these disturbances occur

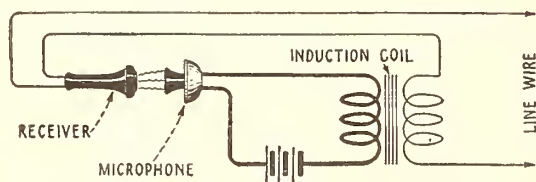

FIG. 3

Illustrating the principle of "feed-back" or regeneration

depends upon the electrical length of the circuit over which the pulsations travel, and the distance at which the receiver is held from the microphone. This rate is usually of such order as to result in a very shrill, screeching noise.

Regeneration in the vacuum-tube circuits is very similar indeed to that outlined above. The grid of the vacuum tube may be likened to the telephone receiver; the electron-filled vacuum between the filament and the plate, to the carbon-granule microphone. Current pulses received by the circuit to which the grid is attached are passed to the grid where they effect a very large change in the flow of the electrons between the filament and the plate. As the charges received by the grid alternate in polarity from positive to negative, the flow of electrons between filament to the plate alternates in magnitude. The current fluctuations in the output circuit are fed back to the grid (input) circuit of the tube. Thus, the grid is charged a second time and a second fluctuation of current in the output circuit results. The magnitude of the current pulse in the output circuit is always greater than that of the pulse which gave rise to it, for the reason that the three-element vacuum tube is an amplifier. Thus the feeding back of the enlarged impulses to the input circuit will result in a still larger fluctuation in the output circuit during the second cycle, and this enlarging action will continue until the resistive forces in the circuit are completely offset.

#### THE HOW AND WHY OF REGENERATION

LET us apply this action in the circuits of Fig. 1. The condenser formed by the antenna and earth, the inductance and the variable condenser across which the antenna (condenser) is shunted, the connecting leads, the by-pass condenser and variometer, or "tickler," in the output circuit of the vacuum tube, all possess inherent qualities which tend

to resist the flow of any kind of electrical oscillation within or through them. If a bit of energy in the form of an electrical current is created in the antenna system, it rapidly spends itself in overcoming this resistive force and, by the time it has reached the point where we expect it to perform its useful function, serious inroads have been made upon it. The extent to which it is dissipated depends, of course, upon the amount of resistance which it is called upon to overcome. But let us assume that the circuit of our diagram (Fig. 1) is average in every respect, and that the resistance encountered is not too great to defeat effective operation. We have insured proper connections in our circuit and lighted the filament of the vacuum tube. Immediately this is done, current supplied by the B battery starts an electron flow across the vacuum from the filament to the plate.

By controlling the electrical length of the output circuit (varying the inductance and capacity in it) let us "time" or tune the journeys of the current pulses in it and transfer a portion of the output circuit energy, *at the proper time*, back into the grid or input circuit. If the timing (tuning) has been properly done, the charge upon the grid will be reënfined by that heavier charge taken out of the plate circuit.

In the ordinary regenerative vacuum-tube receiver, the electron discharge of the tube and the power stored up in the batteries may be called upon to an extent sufficient to generate oscillatory energy at a very rapid rate. An antenna of two or three hundred ohms—and this is quite a high resistance—will not serve to prevent this vacuum tube action from compensating for the resistance of the circuits. It is for this reason that the regenerative circuit has proven so effective as a radio receiver. Theoretically, no matter how inefficient may be the units which comprise the circuit, the vacuum tube, by regeneration, makes up for inefficiencies, but practically efficient units are of as great advantage in the regenerative receiver as in any other type, for, it will be remembered, the vacuum tube does not compensate for circuit inefficiencies when it is not carefully adjusted to a point just below oscillation or when it is not actually oscillating. The value of efficient units, therefore, is apparent in the preliminary adjustments necessary when tuning in a station, when it is impossible to hold all circuits at this critical



point. The currents upon the grid are those which control the action outlined. The character of the oscillatory currents in the whole circuit are determined by the form or character of those which reach the grid from the antenna. The circuit which we have been treating above is that of the single-circuit receiver. When the currents in the grid circuit of this receiver have been reinforced by the feed-back of energy, the currents in the antenna circuit have also been reinforced, for grid and antenna circuits are so closely coupled by the inductance and capacity common to both of them, that they act as one.

#### WHERE THE THREE-CIRCUIT RECEIVER DIFFERS

**I**N THE three-circuit receiver of Fig. 2, this is not true. For example, let us assume that the vacuum-tube circuits are quiescent, and that a signal pulse arriving upon the antenna induces a like signal current in the secondary circuit of Fig. 2. The charge arriving upon the grid as the result of this inductive action will be slightly smaller than that charge arriving upon the grid had the grid circuit and antenna circuit been very closely coupled, depending upon the excellence of design of the receiver circuits. But, this slight loss, along with other losses of the circuits, may be, and is, fully compensated for by regenerative action and the signal built up and up in the system until its value is equal to or greater than that of the energy placed in the antenna by the passing electric wave. As the regenerative energies in the grid circuit grow larger and larger, their tendency toward control of their own destiny becomes greater and greater. Conversely, their dependence upon the form or nature of those oscillations in the antenna circuit be-

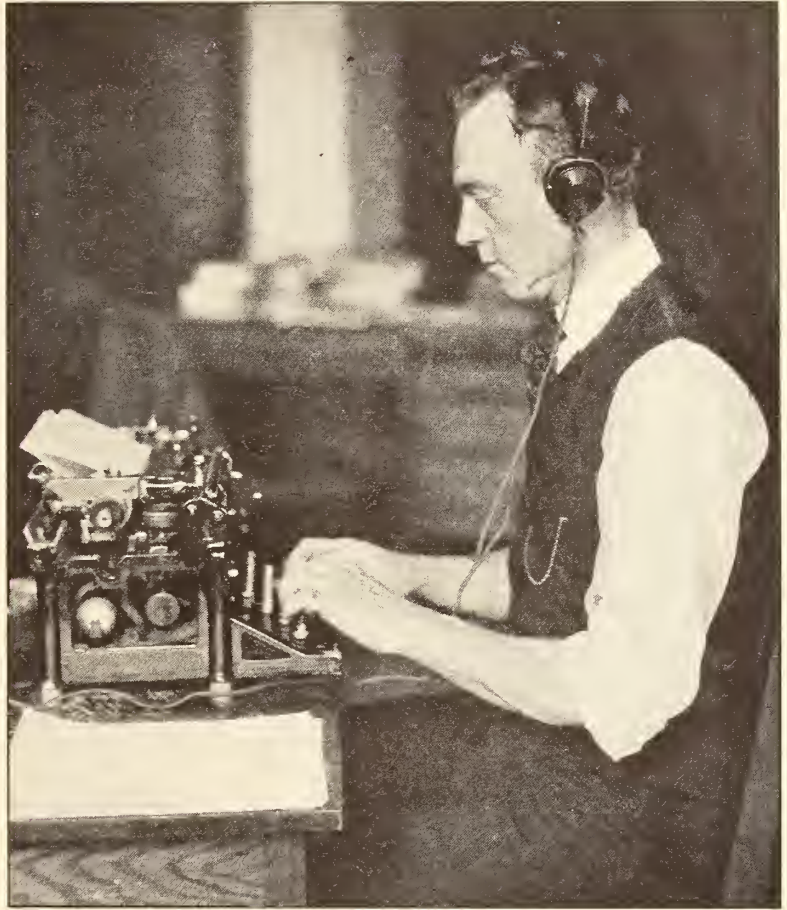

#### KEEPING IN PRACTICE

Paul Godley taking copy from the New Brunswick, N. J. transatlantic station at 50 words a minute

comes less and less, and this divergence may increase until they are, in effect, unguided by the form of the oscillations in the antenna circuit. Therefore, if coupling is too loose, distortion will set in. When it is too tight, it is impossible to secure the maximum benefits of regenerative amplification. Between the two lies the ideal—some arrangement which provides control over the coupling between the antenna and grid circuits and which makes it possible for us to reach this ideal.

In the case of the three-circuit receiver, the regenerating circuits are working upon a *slightly* weaker initial signal and when too loosely coupled are prone to distortion, resulting from lack of guidance. In the single-circuit receiver the guiding forces are 100% present and there are, in addition, many other stray forces—forces existing in the antenna due to shocks which it receives from powerful

"off-wavelength" oscillations which pass through it. These forces may have been caused by powerful amateur or ship or naval stations, by discharges of faulty electric lines, telephone circuits, "buzzer" circuits, and what not. From the foregoing it may be understood why the single-circuit receiver is subject to these disturbances and it may also be understood why the three-circuit receiver, comparatively, is free from them.

Where the regenerative circuits are to a large degree freed from external influence, they may be *very gradually* adjusted toward those settings where maximum regeneration without oscillation (and therefore maximum undistorted signal) is had. Let us suppose this freedom is lacking. When the adjustments are approaching a very critical setting, if some disturbing external influence suddenly throws into the circuit a powerful pulse, the pulse is repeated through to the output circuit and in its greatly enlarged form, back into the grid circuit. Thus the circuits are suddenly thrown into oscillation and the signal distorted. Where the antenna circuit is directly coupled to the grid circuit, this effect is continually taking place. It makes it impossible to secure a maximum of undistorted regeneration, so that, whereas in the case of the direct-coupled circuit the *initial* signal is slightly larger, it never can be so greatly enlarged due to regenerative action as in the coupled circuits.

Although the key to the ideal case for the regenerative receiver lies in the control of the coupling between antenna and vacuum-tube circuits, the idea must not be had that a continual adjustment and read-

justment of this coupling value is necessary. In a well designed receiver it is not. For a given band of wavelengths, say, 360 to 400, and a given antenna, the value of this coupling may be chosen and allowed to rest. This value varies greatly for different antennas, depending upon their resistance, and it may vary slightly for fairly large changes in wavelength, for the resistance of any circuit will change with wavelength.

The observing reader will have foreseen the result of the coupled-circuit receiver with regard to what is known as selectivity—freedom from undesired signals. And, too, he will have noted that in so far as manipulation of the circuits within a given band of wavelengths is concerned, he has three variable controls to deal with instead of two. In the single-circuit receiver there is the wavelength dial—the dial which governs the wavelength of the antenna-grid circuit and the regenerative control. In the three-circuit receiver there are the wavelength dials of the grid circuit and the dial which serves to keep the antenna circuit in resonance with the grid circuit, and the regenerative control. To be sure, there is no technique required to operate the one, while a certain amount of technique *is* required to operate the other; but who does not take pride in the mastery of a thing, and who is there that enjoys the radio concert or the conversation with a friend half a continent away, who would not give a few hours of application to technique in order that his pleasure may be increased by freedom from disturbance, and by the knowledge that he is causing a minimum of interference to others?

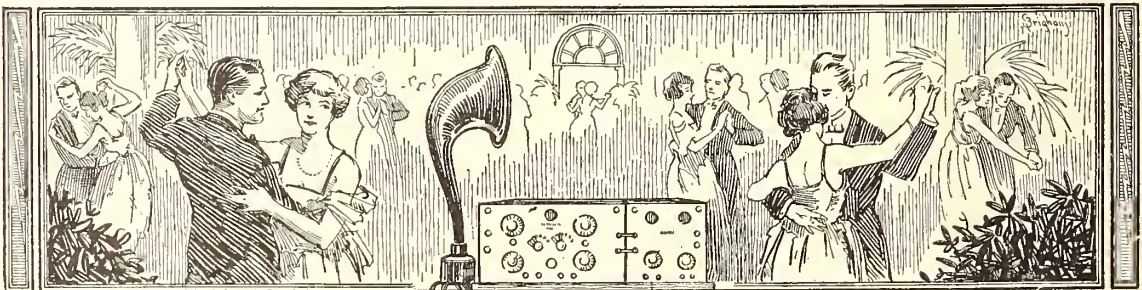



# International Law and the Sea-Going Telegrapher

By CLAUDE CATHCART LEVIN

Associate Editor of *The American Officer*

UNDER the provisions of The London International Radio-telegraphic Convention of 1912, the nations signatory thereto bind themselves to take or propose to their respective legislatures the necessary measures for insuring the carrying out of the Convention's regulations.

Thus the radio laws and regulations of the U. S. are fundamentally those of the London Convention, as are also those of the other signatories.

Great Britain, however, realizing the inadequacy of laws framed in 1912 as applied to modern communication, has gone much farther and has passed legislation affecting radio which stands as a model and which will undoubtedly have great influence in the next convention whenever it is held.

Under British law, ships are divided into three classifications:

1. Those carrying 200 or more persons and not engaged in British coastwise trade.
2. Ships not engaged in British coastwise trade carrying 50 but less than 200 persons, and ships engaged in British coastwise trade carrying 50 persons or more.
3. Ships carrying less than 50 persons.

The rules in general require that a vessel of the first class shall carry three licensed radio operators; that a vessel of the second class shall carry one certificated operator and two certificated watchers, and that a vessel of the third

class shall carry one certificated operator. The "certificate" corresponds to the "license" issued to radio operators by the American Government.

The provisions of the act apply to all vessels, foreign as well as British, of 1,600 gross tons and over touching at British ports, and are now in force throughout the United Kingdom, Australia, and India.

These provisions are far ahead of those of America and the other nations which have not passed similar legislation and which are operating under their own laws based upon those of the Convention.

Under the provisions of the Convention, ship stations in constant service are required to have on board at least two certificated radio operators, who will maintain constant service

(this on vessels carrying 50 or more persons and traveling certain distances). On ships carrying less than 50 persons, radio is not compulsory.

The application of the British law to vessels of all other nations was quickly felt. Italy soon passed similar legislation, with the result that the situation there is practically the same as in the United Kingdom, except that they have no watchers. (A watcher is a person certified to be able to receive a distress signal at a slow rate of speed and is not required to fulfill the regular duties of an operator.)

Norwegian, Danish, and Scandinavian vessels were particularly affected and were forced to place radio on many ships which had not

## The Radio Man at Sea

The best of laws become obsolete, and we find it hard to reconcile our present activities in radio with the law of 1912. From the point of view of the operator, that law is far from satisfactory, and it is true that although conditions at sea are not entirely despicable—as some of the more radical unionists would have us believe—there is plenty of room for improvement.

The author has been in close touch with the matter and has served as President of the United Radio Telegraphers' Association. He is Associate Editor of *The American Officer*, a marine publication, and is conversant with marine radio affairs. RADIO BROADCAST would like to receive articles on the subjects discussed in this article from other men who are helping to make life safe at sea.

—THE EDITOR.

been equipped before. Recent press dispatches state that the Danish Parliament is considering the passage of legislation similar to the British act in order that their ships may not be handicapped, as foreign vessels visiting Danish ports will then be required to comply with the laws.

French law is rather involved, being designed to conform to the requirements of the naval and military services as well as of the merchant marine.

Especially during the last few years, the world has greatly felt the need of new, unified, international radio legislation to suit present conditions and to provide for the future.

The framers of the London Convention, realizing that the art would grow beyond its stage of development in 1912, provided in part as follows:

The provisions of the present Convention and of the Regulations relating thereto may at any time be modified by the High Contracting Parties by common consent. Conferences of plenipotentiaries having power to modify the Convention and the Regulations shall take place from time to time; each conference shall fix the time and place of the next meeting.

It was agreed that the next Conference should be held at Washington in 1917.

Owing to the war it was decided to postpone the Conference. At the Peace Conference at Paris in 1919, the following agreement was reached with respect to calling an International Electrical Communications Conference:

The Principal Allied and Associated Powers shall, as soon as possible, arrange for the convoking of an international conference to consider all international aspects of communication by land telegraphs, cables and wireless telegraph, and to make recommendations to the Principal Allied and Associated Powers with a view to providing the entire world with adequate facilities of this nature on a fair and equitable basis.

A preliminary conference of representatives of Great Britain, France, Italy, Japan, and the United States was held at Washington, beginning in October, 1920, for the purpose, among other things, of preparing an agenda for the International Electrical Communications Conference. The reports adopted at this Conference have been submitted to the governments of the world for their comments and the United States Government has received many replies.

United States Representatives accredited to

governments which have not as yet furnished an expression of their views concerning these reports have been instructed to endeavor to obtain a statement of the views of these governments.

The replies which have been received are being studied, and careful consideration is being given to the matter of determining when further action shall be taken by this government with respect to the next International Radiotelegraphic Conference.

A short time ago there met in Brussels representatives of professional radio telegraphist associations of Belgium, Denmark, Great Britain, Holland, Greece, Italy, and Sweden, and here was formed The International Federation of Radiotelegraphists.

Realizing the great need of new International Legislation, the Federation adopted the following resolution on behalf of its members, the sea going radiotelegraphists of the world:

1. To secure adequate representation on any international authority dealing with wireless matters affecting the position of marine radiotelegraphists.
2. To secure the uniform and satisfactory application of wireless telegraphy on board ship so as to assure the maximum degree of safety of life at sea.
3. Instructing the Secretary to demand recognition by the International Radiotelegraph Convention, and to ask that at least one representative from the Federation should be present at the next Convention. Fixing the basis for an international manning scale.
4. Calling for the introduction of uniform classes of certificates by the International Radiotelegraph Convention.
5. The collection and dissemination of news and information regarding the state of the profession, etc., in various countries.
6. That the operation of wireless telegraphy at sea in all its branches be performed only by qualified operators.
7. That the English and French languages be learned by operators.

The United States Government has received an invitation from the French Government to participate in the International Electrical Communications Conference which it is proposed to hold at Paris this year. It has not yet been decided, however, whether this government will accept the invitation of the French Government, and an announcement concerning this is expected shortly.





# Soldering Your Own

By W. S. STANDIFORD

**O**F THE many people throughout the United States and Canada who are making and installing their own sending and receiving sets, the majority are comparatively "new to the game" and have trouble in getting soldered joints that will remain firm. *It is of great importance to the working of any radio outfit that a clear path for the electrical energy (which at its best is very weak) should be provided, so that no buzzing sounds due to loose connections are heard along with the signals.*

Soldering wires on variometers and other parts is easy, once the knack of handling a soldering iron is learned. It is better for those who have never done work of this kind to try it first on some spare pieces of copper wires twisted together. Soldering irons, or coppers as they are termed, range in weight from a few ounces to several pounds. They can be either made or bought. The lighter ones are easier to handle, but lose their temperature very quickly compared to the heavier irons. One weighing about three fourths or one pound (shank and handle not included) is about right for most radio work. The soldering iron shown in the accompanying photograph weighs close to one pound, and was made by the writer from a one-inch copper bar, the shank being made from a poker, and the wooden handle obtained from an old broom.

In order to do good work in soldering, five things are essential. The point of a soldering iron has to be coated with solder or "tinned," as it is termed by men who make a living doing this work. The portion to be joined must be made very clean, either by scraping with a piece of a sharp knife blade kept for this purpose, or filed, or rubbed with emery cloth—whichever method proves the handier. The parts that need soldering ought to be heated above the melting point of solder. In ordinary classes of small work, such as soldering one wire to another or sheets of metal to other sheets, the

heat of the soldering iron itself must be sufficient not only to melt the solder, but also to raise the temperature of the metal to be fastened together, so that firm joints are made.

Do not let your iron get too hot, that is, red-hot; or it will not take up any solder at all. Lastly, it is best to keep the iron well tinned at all times, so that when you want to use it, it is always ready, and you will thus save time by not having to re-tin it. New irons sold in hardware stores are in the rough state, with no tinning upon their points. Most of them also have no handle, which has to be bought separately. It is necessary after one is put on, to smooth the four sides of the iron with a medium coarse file so as to make the tin stick to it. To tin these sides, put the iron in a clear, red coal fire, which is not giving off any smoke. Heat it until nearly red-hot. When it has the right degree of heat, the solder will melt instantly when it is applied to the iron. At this stage, if it is held about 3 inches away from the palm of the hand, the heat given off from the hot metal may be felt. This will serve as a guide for future heatings instead of touching solder to the tool.

Have some powdered rosin, together with solder, on a board. Quickly brighten one face of the soldering iron with a file or a piece of sandpaper tacked on a block of wood and then rub it rapidly into the rosin and solder mixture. The surface of the copper bit will be found to have taken a shiny coating of solder. Repeat this process with the other sides until they are tinned. If it should happen that a soldering

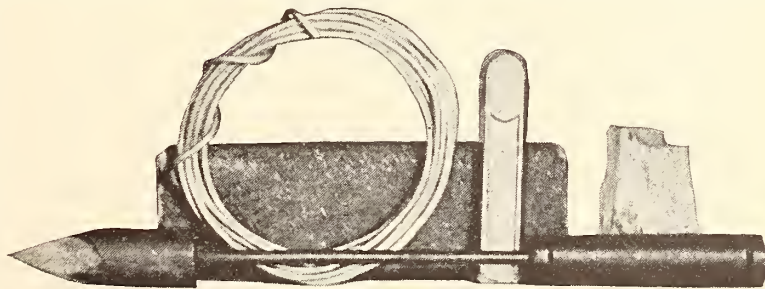

A "TINNED" SOLDERING IRON AND ACCESSORIES

Behind the iron are a coil of wire solder, a bar of "half-and-half" solder (composed of tin and lead), a strip of emery paper tacked on a wooden block, and a lump of sal ammoniac

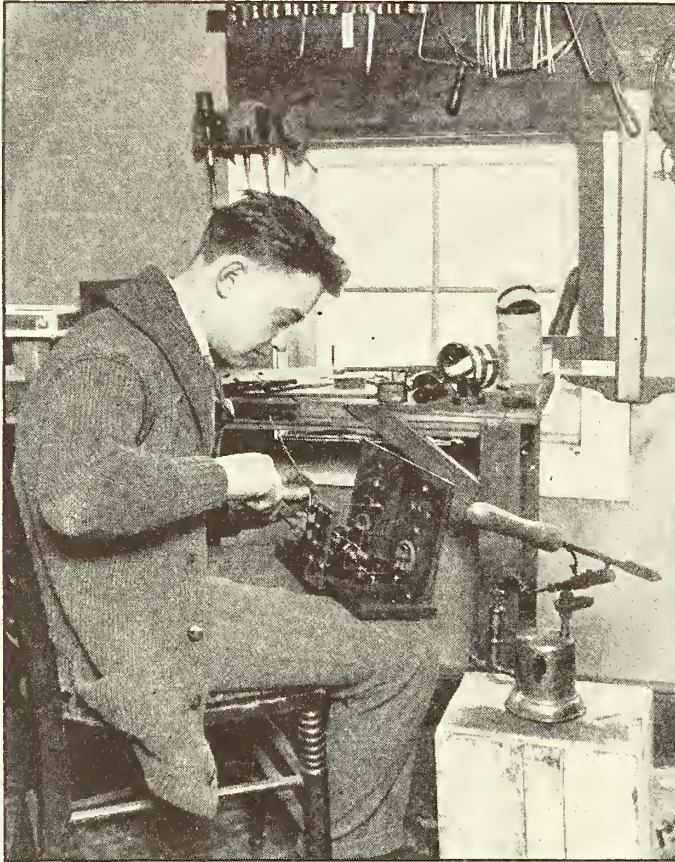

TO SEE YOUR APPARATUS GROW UNDER YOUR HAND  
From a heterogeneous mess of parts into a neat, well-soldered radio receiver, and to connect up that receiver and pull in signals—distant signals—that is truly a “gr-r-rand and glor-r-rious feelin’”

iron refuses to take a tin coat, heat the copper a bit more, but not red-hot; file its face and rub it on a lump of sal-ammoniac to remove any grease, then plunge into the rosin and solder flux. A few trials will enable any novice to do good tinning work.

Once the nose of an iron is “tinned”, it will remain so, provided it has not been overheated so as to burn off the solder or cause it to become alloyed with the copper. This condition can be easily recognized because the surface of the copper turns black. If this occurs, file and re-tin the four sides.

Having coated the tool with tin, you can proceed to use it on the wires of your radio outfit, it being presumed that you will have practiced soldering other pieces of wire before trying this work on your apparatus. A description of fluxes and their action will be touched upon, as fluxes play a most important part in soldering work. The main reason for

using fluxes in order to make joints that will not become loose, is that a thin film of oxide always forms upon all brightened surfaces of metals, this oxide being caused by action of the air. Fluxes dissolve and prevent any further oxide forming and thus allow the solder to stick directly to the metallic body, instead of to an oxide film which, sooner or later, allows the joints to come apart.

To solder twisted wires on vario-couplers, untwist the ends, scrape the insulation off the ends, and brighten them with emery or sandpaper. Then coat them with rosin flux, taking care not to get any of it on the insulation. Heat the iron in a gas or coal fire until it has acquired the right temperature, when the solder on its tinned surface will be observed to melt. This shows it to be hot enough. Remove it from the fire, give it a quick rub on a piece of old carpet or heavy rag and touch it to a bar of solder. A drop of the latter will adhere to the iron and can be conveyed to the wires that need uniting. Hold the hot copper on the junction. As soon as the wires are hot enough, the solder will leave the iron and flow over them. Re-

move the iron, but do not disturb the joint until the solder has set. This will be shown by a sudden dulling of its surface. It may be necessary to add more solder to the joint. In this case, add more flux and put on another drop of metal.

Some radio fans use aluminum wires for aerials and try to solder the joints with ordinary “half-and-half” tinner’s solder and then wonder why it does not stick to the wires.

Aluminum has an oxide on its surface which reforms as quickly as it is removed. For this reason a special solder is needed. If possible, a radio enthusiast who desires to use an aluminum wire aerial should have a wire long enough to reach the binding posts of his set without any soldered connections in it. Should this be impracticable, then resort will have to be made to a soldered lead-in wire. If this work is done with a solder and flux of the formula given, aluminum wires may be united with



little trouble. The formula for aluminum solder is 79 per cent. tin, 20 per cent. zinc, and 1 per cent. aluminum. Obtain a dry, grooved board with a slot cut in it the thickness of a lead pencil. Stop up both ends and pour the hot metal from the iron ladle into it. The flux is composed of equal parts of stearic acid and rosin, melted together and well stirred. A bar of common yellow laundry soap melted up with a sufficient amount of rosin so as to make a mixture that can be spread on with a stick, will also make a good flux.

Heat the place on the wire with a blow torch until it is hot enough to melt the solder (which differs in the ordinary variety in that it flows more sluggishly), then quickly rub the hot surface with flux and tin it well with the solder,

pushing the latter backward and forward. This removes the oxide and prevents any more from forming. When both wires are thoroughly "tinned," wind one over the other in the usual manner. Heat the joint again and apply more flux and solder so as to cover both parts well. In aluminum soldering, it is better to have each wire covered with a plentiful supply of solder so as to exclude moisture. This solder will impart a strength to a joint nearly equal to the strength of the metal itself. An aluminum soldering "iron" will be found to work better than a copper one, although the latter can be used successfully for aluminum work. Joints on outside aerials should be painted with several coats of spar varnish, to keep out the moisture.

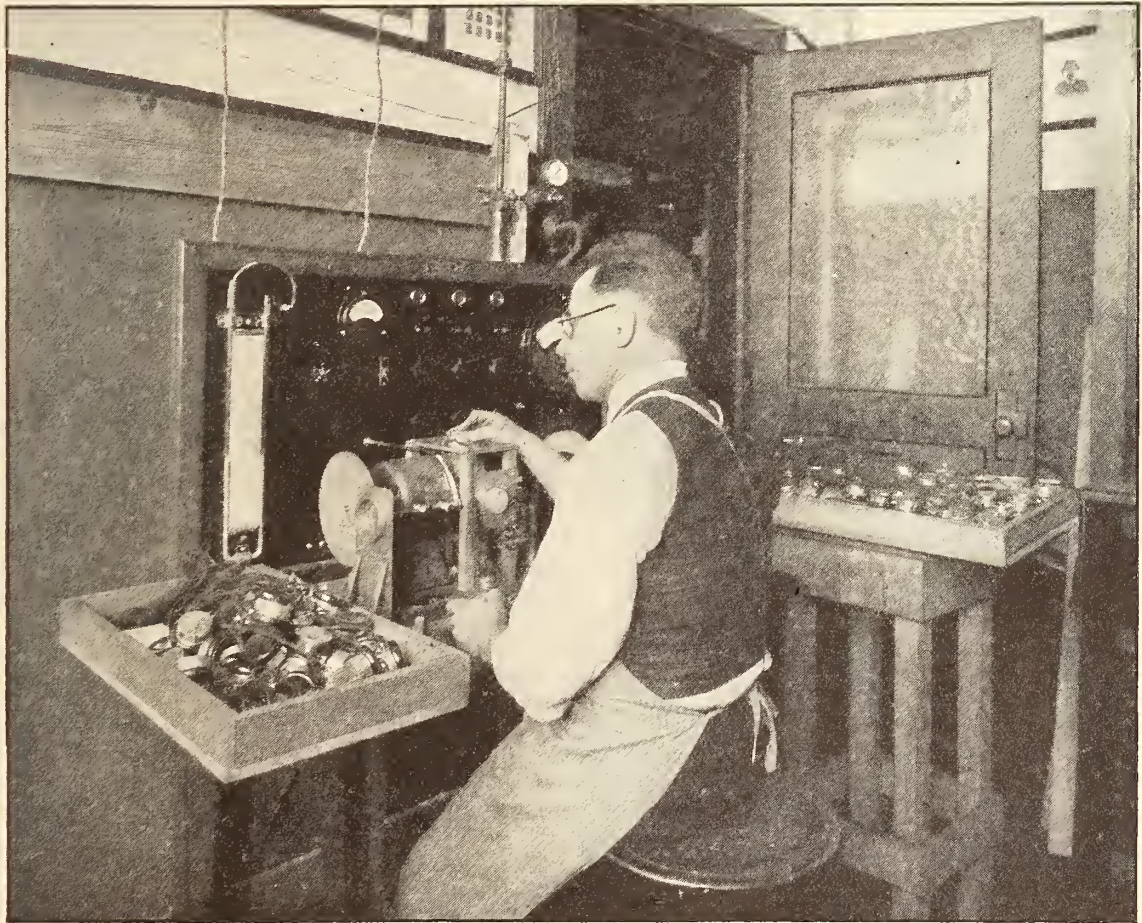

TESTING TELEPHONE RECEIVERS

In the factory of the Holtzer-Cabot Company. The operator is able to determine the tone quality, distortion, and volume of the receivers, directly from the meters, as readily as one can determine resistance by the use of a Wheatstone Bridge



# Broadcast Receiving Contest!

## Any Number of Tubes—Any Kind of Receiver

THE LONG-DISTANCE RECEIVING CONTEST, to determine who has done the best with ANY NUMBER OF TUBES AND ANY TYPE OF RECEIVER, is in full swing. The drawbridge will be hauled up at sunset on MAY 31st, however, and after that even the most imposing-looking contributions will have to be left outside the portcullis. A great many of them will probably gallop through in a cloud of dust at the last minute—but that is dangerous business, and we advise you not to try it. Read through the Eight Commandments below, roll up your sleeves, and go to it.

### The Four Prizes

#### First Prize: DE FOREST D-7 REFLEX LOOP RECEIVER

This receiver, described in RADIO BROADCAST for February (page 297), is the latest product of the De Forest Company: it makes three amplifying tubes and a crystal detector do the work of six tubes. The loop antenna aids in selectivity because of its directional properties. An ordinary antenna and ground may be used, however, if desired. Recently, a man in Brooklyn, N. Y. heard a broadcasting station in Seattle, Wash., with one of these sets.

#### Second Prize: GREBE TUNED RADIO-FREQUENCY AMPLIFIER, TYPE "RORN"

This amplifier, which has a wavelength range of from 150 to 3000 meters, may be used with any form of home-made or bought receiver. It is the most recent development of a company widely known for the excellence in design and workmanship of its products.

#### Third Prize: Choice of

THREE OF THE NEW RADIOTRON UV-201-A AMPLIFIER TUBES (6 volts,  $\frac{1}{4}$  of an ampere), or

THREE AERIOTRON WD-11 DRY CELL TUBES ( $1\frac{1}{2}$  volts,  $\frac{1}{4}$  of an ampere).

#### Fourth Prize: TIMMONS LOUD-SPEAKER UNIT

This unit, which may be connected directly to the output of your amplifier, has a diaphragm adjustable for sounds of different intensities, and when used with two stages of amplification reproduces broadcast programs about as loud as the music from the average phonograph.

### Rules of the Contest

1. You should list all broadcasting stations 150 or more miles away from the receiving point, which you have heard distinctly (announcement of location as well as of call letters.)
2. Measure distances accurately, and give aggregate mileage. (This is the sum of all the distances, each station counted once, but two or more stations in the same city being counted separately.) An aggregate mileage of less than 15,000 miles will not be considered.
3. Manuscripts should include the following: description of set, directions or advice for constructing and operating it; any "wrinkles" or makeshifts which you have used to advantage; photograph of your apparatus; circuit diagram; in general, anything you have to tell that will make your story more interesting and helpful. Manuscripts should not be longer than 2000 words. Typewritten ones preferred.
4. Data should be arranged in three columns, under the headings: call letters, location, distance.
5. For material used, a liberal rate will be paid.
6. In judging contributions, the quality and interest of photographs, text, and drawings, and the originality and general effectiveness of the apparatus described, will have greater weight than the list of stations heard, although a long list of distant stations will distinctly help.
7. The Contest closes May 31st, 1923.
8. Address: Receiving Contest, RADIO BROADCAST, Doubleday, Page & Co., Garden City, N. Y.





## A Bit About Books



ONE of the best books designed to assist the broadcast listener and the amateur to know who is on the air is "The Citizens' Radio Call Book." It contains the call letters of American and Canadian Broadcasting and Amateur Stations; Experimental and College Stations; Naval Radio Stations; press schedules of radio stations throughout the world and a list of high-power trans-ocean stations. It is arranged in a very convenient manner and is well worth its price: fifty cents.

Citizens Radio Service Bureau, 416 So. Dearborn St., Chicago, Ill.

In a thirty-two page booklet called "Getting Acquainted with Radio Receivers," Paul Godley has told a great deal about the use of receivers for broadcast reception. Mr. Godley's work is truly a short course in radio-electricity. Much of the book is devoted to the installation and operation of "Paragon" receivers, but there is a wealth of information which will be found valuable by the operator of any type of regenerative receiver. The book may be had for twenty-five cents.

Adams-Morgan Company, Upper Montclair, New Jersey.

"Radio Reception" by Harry J. Marx and J. Adrian Van Muffling, is a real radio book and is full of practical information for the fellow who builds his own. It is simple and complete and well illustrated. The book contains 92 illustrations and 38 diagrams, and includes a brief outline of applied radio-frequency amplification.

G. P. Putnam's Sons, New York City.  
Price \$2.00.

A rather complete book on radio from the early days to the present, from crystal receivers and double-slide tuners to super-regeneration and the transmission of photographs by radio is Dr. Henry Smith Williams' "Practical Radio." There are a great many illustrations which serve their purpose admirably. The functions of various radio devices are clearly and correctly portrayed and described in a helpful and interesting manner. Here, indeed, is a volume of worth for the beginner and the more advanced enthusiast. It is just what its name implies—Practical Radio.

Funk & Wagnalls Company, New York City.  
Price \$1.75 (\$1.87 postpaid).

"Letters of a Radio Engineer to His Son" is a book designed for those who would understand the reason for various actions that take place in a vacuum tube whether it be employed for receiving or transmitting. John Mills, the author, has told this story in a very complete and comprehensive manner, but these letters would hardly interest the average son unless he is well along in high school. If the book you seek is one on "how to make it," this is not the book for you, for, although it explains design in a complete manner, no attempt is made at assembly and panel layout. There are more helpful books for those who build their receivers and transmitters from standard parts, but for the person who takes pleasure in designing his own units this work is of great value.

Harcourt, Brace & Company, New York.  
Price \$2.00.

# All Boy Scouts, Attention!

RADIO BROADCAST announces a contest, starting now and ending July 31, 1923, to determine WHAT BOY SCOUT TROOP HAS DONE OR IS DOING THE MOST WITH RADIO.

## Prizes for Winning Articles

**FIRST PRIZE: CROSLY MODEL X 4-TUBE RECEIVER.**

This receiver, which may be used with dry-cell tubes if desired, consists of detector, one stage of tuned radio-frequency and two stages of audio-frequency amplification. (Advertised in RADIO BROADCAST).

**SECOND PRIZE: MUSIC MASTER LOUD SPEAKER.**

This is the new loud speaker made by the General Radio Corporation. (A picture and description of it appear in the advertising pages of RADIO BROADCAST).

**THIRD PRIZE: THREE**

The WD-11 is the well-known dry-cell tube manufactured for the Radio Corporation. (Filament voltage 1.5,

A YEAR'S SUBSCRIPTION TO given as prizes for the ten next best

These prizes will be awarded to troop may delegate one of its members to

WD-11 VACUUM TUBES.

cell tube manufactured for the Radio plate voltage 22½—45).

"RADIO BROADCAST" will be contributions in this contest.

troops, not to individuals, although any prepare the story.



## Rules of the Contest

1. Articles must be true accounts of radio with relation to your particular troop: what you have done, or are doing, or both.
2. Every article must be written by a Scout or by more than one Scout belonging to one troop.
3. Articles should be between 500 and 1000 words long.
4. Good photographs to illustrate the article will count 50% in judging contributions.
5. Typewritten manuscript, double-spaced, is desired, though not required.
6. Address contributions to Scout Contest, Radio Broadcast, Doubleday, Page & Company, Garden City, N. Y.

Scouts have done splendid work in maintaining communication by radio in time of floods and disaster, in copying and spreading the market reports transmitted by the government Farm Bureaus, in training themselves along mechanical and electrical lines, and, in short, in using radio as a part of scout work in a way consistent with the best traditions of scouting. What have you to tell of your troop's past or present activities? Get your scribes and photographers under way with that story which will put in a strong bid for first prize. How would a receiver with three stages of amplification go in your troop?

Beginning with the July number of RADIO BROADCAST, the best articles will be published. The winners will be announced in the September number, and unless the three best articles have been previously published, they will appear in that issue.

## Next Month—More About the Grimes Circuit

The article by Mr. Charles H. Durkee in our April number, "1300 Miles on a One-Foot Loop," resulted in a deluge of correspondence from interested readers. The article described the "Inverse Duplex" receiver developed by Mr. David Grimes, of Staten Island, N. Y.

RADIO BROADCAST has arranged to have Mr. Grimes explain to you, next month, how you can construct this receiver and how it should be adapted for use with various types of tubes now on the market. It is the ideal vacation outfit.—THE EDITOR.



# New Wavelengths for Class B Stations

Revised Schedule, Issued by Department of Commerce, in Effect on May 15th

**T**O CLEAR up the congestion in radio broadcasting, says the *New York Times*, a new schedule of wavelengths, going into effect on May 15, has issued from the Department of Commerce, which has been working on the problem ever since the recent National Radio Conference.

Definite wavelengths have been allocated to each of five zones into which the country has been divided, and broadcasting stations will have to adhere to these or suffer the penalty of loss or suspension of license.

For the Class B stations (the high-power transmitting agencies) there will be ten wavelengths in each zone, and each of these will be adjusted so as not to conflict with any other.

Of the ten zone lengths assigned to Zone 1, which extends from New England through the District of Columbia, three of them, 405, 455, and 492 meters, have been assigned to New York City and Newark. This is because so many persons are served by the stations in the neighborhood, and so much entertainment talent is available. The stations in New York and Newark will have to arrange for division of time.

Other assignments of wavelengths thus far in this zone are:

Springfield, Mass. (Westinghouse station) and Wellesley Hills, Mass., 337 meters.

Schenectady (General Electric), and Troy (Rensselaer Polytechnic), 380 meters; Philadelphia (Wanamaker's, Lit's, Strawbridge & Clothier), 509 and 395 meters, and Washington (Arlington and Radio Corporation), 435 meters. It is likely that Arlington will have a special wavelength and not be forced to divide time with any other station. Wavelengths of 303, 319, 469 meters also are reserved for this zone.

Assignments in the other zones up to this time are:

Zone 2—Pittsburgh, 326; Chicago, 448;

Davenport and Des Moines, 484; Detroit and Dearborn, 517; Cleveland and Toledo, 390; Cincinnati, 309; Madison and Minneapolis, 417.

Zone 3—Atlanta, 429; Louisville, 400; Memphis, 500; St. Louis, 546.

Zone 4—Lincoln, Neb., 341; Kansas City, 411; Jefferson City, 441; Dallas and Fort Worth, 476; San Antonio, 385; Denver, 323; Omaha, 527.

Zone 5—Seattle, 492; Portland, 455; Salt Lake City, 312; San Francisco, 509 and 423; Los Angeles, 395 and 469; San Diego, 536.

## NOTHING ABOVE 600

None of the wavelengths goes above 600 meters. This is important to amateurs, as according to a plan proposed to the recent conference the large stations might have had wavelengths up to 700 meters, which would have necessitated the changing over of many receiving sets.

Besides the Class B stations, which broadcast to long distances, there are 540 Class A stations which use the 360-meter wavelength. These will be allowed to retain that wavelength or can come into a special band between 222 and 300 meters. If a new station is erected and it cannot meet the qualifications of a Class B station it will not be allowed to use 360 meters, but must go into the 222-300 band.

Because of the great activity in radio, the Department of Commerce is enlarging its forces in the inspection districts of which there are nine with Boston, New York, Baltimore, Atlanta, New Orleans, San Francisco, Seattle, Detroit, and Chicago as headquarters.

Beginning May 15, inspectors will check the wavelengths of stations in their districts.

It was stated that any station now operating on 360 meters has the privilege of remaining on that wavelength. It is also emphasized that the assignments of wavelengths are for cities and not for specific stations.

# The Grid

## QUESTIONS AND ANSWERS

The Grid is a Question and Answer Department maintained especially for the radio amateurs. Full answers will be given wherever possible. In answering questions, those of a like nature will be grouped together and answered by one article. Every effort will be made to keep the answers simple and direct, yet fully self-explanatory. Questions should be addressed to Editor, "The Grid," RADIO BROADCAST, Garden City, N. Y. The letter containing the questions should have the full name and address of the writer and also his station call letter, if he has one. Names, however, will not be published.

### LOOPS

*The writer would appreciate publication, in an early issue of RADIO BROADCAST, of information concerning the construction of a loop antenna.*

H. H. S., Pittsburg, Pa.

**I**N WRITING to *The Grid* for constructional data, correspondents are requested to furnish the editor with all possible information concerning the use to which the apparatus is to be put. This should include, when pertinent, frequency (supply line), wavelength, voltage, current, sizes, the experience of the correspondent and a description of available material. This will greatly add to the facility with which our advice may be carried out, and to the general usefulness of this department.]

It is assumed that our inquirer desires to construct a loop for broadcast reception. The most desirable size for such a purpose is a compromise between the more efficient larger sizes and the convenience and mobility of a small frame—a square loop, three feet on a side, the various dimensions of which are indicated on the working drawing of Figure 1.

The loop is of the solenoid type, i. e., wound in "box"

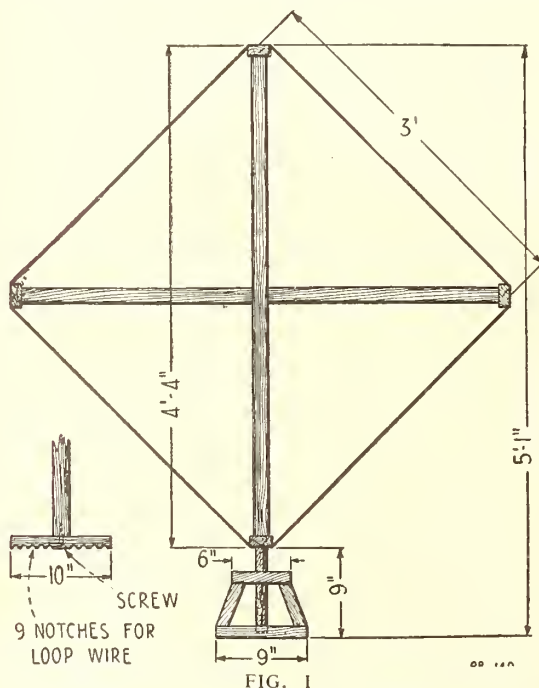

Showing dimensions for a loop for broadcast reception

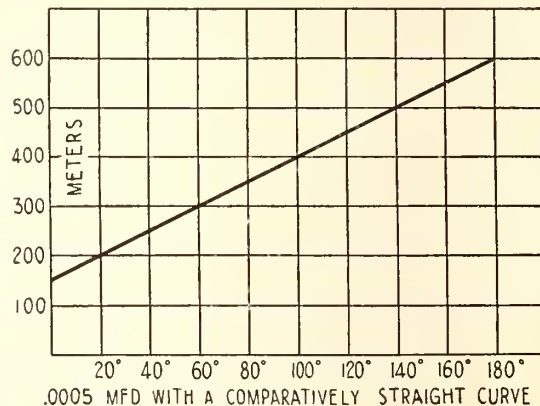

FIG. 2

form rather than as a spiral. There are nine turns of wire, separated one-half inch. There are grooves sawed in the end pieces. Any convenient wire may be used. Green double silk covered, number eighteen, is perhaps the most easily manipulated, and when wound on a stained frame, the finished loop presents a very creditable appearance.

The frame is constructed of one by one-and-a-half inch lumber. The upright may be drilled at the lower support on which the wires are strung to pass the middle wire. The other wires of course pass on either side of the upright. The construction of the base is clearly shown, the holes through the top and into the bottom being one inch in diameter, and the lower eight inches of the upright rounded to fit with sufficient looseness to permit turning.

Figure 2 shows the approximate wavelength range of this loop when shunted by the average .0005 mfd. plate condenser.

The indoor loop, as described, will give satisfactory results only when used with radio-frequency amplification. Employing two stages of transformer-coupled, or one stage tuned plate R. F. amplification, detector and two steps of audio-frequency amplification, stations one thousand miles distant should be received with very good audibility.

### A. C. FOR RECEIVING FILAMENTS

*Is there any possible way in which I can light the filament of my detector bulb from 110 volts alternating current? I thought, perhaps, the A. C. could be stepped down to six volts by a transformer, and this changed to direct current through a rectifier. Choke coils would be used to smooth out*



A Millionaire's Cruise on an Operator's Pay



# RADIO BROADCAST

July, 1923

7, 3, 43



The "Inverse Duplex" With Various Tubes

Making Radio Your Business

A Home-Made Amplifier for Any Receiver

Dry Cells and UV-199's



25 Cents

Filament Current .06  
amp. Mutual Conductance  
337 Micromhos at  
40 volts plate and 0  
grid potential.



Type C-299  
Price \$6.50

Cut shows actual size of tube  
3 inches high

Announcing the New



*Cunningham*

## Dry Battery Detector and Amplifier Tube

Designed by the engineers of the General Electric Company's great research laboratories, this new dry battery tube, type C-299, is by far the most economical vacuum tube ever placed on the market for amateur, experimental and entertainment use.

It has been designed for use as a Detector and Amplifier of both radio and audio-frequency currents. The filament is lighted from three 1½ volt dry batteries in series, and the filament current is only .06 of an Amp. This is less than one fourth of the current of any previous type of dry battery tube. This feature makes it possible to use four of these tubes in parallel, with only one set of three dry batteries.

The C-299 has practically the same operating characteristics as the previous Cunningham Amplifier, type C-301. Due to the low distributive capacity of the elements it is an excellent radio-frequency amplifier. When used as an audio-frequency amplifier the output from two steps is sufficient for the operation of a small loud speaker.

Bulletin No. 2-B describes this new tube in full and gives the necessary data regarding rheostats, battery voltages, transformers, etc. A free copy will be sent to you by return mail, upon receipt of your request at either of the addresses given below. Complete instruction sheet for its care and operation is packed with each of these New Cunningham Dry Battery Tubes, type C-299.

*R. J. Cunningham*

248 First Street, San Francisco, Calif.

154 W. Lake Street, Chicago, Illinois

★ Tested and approved by RADIO BROADCAST ★



# Just one Reason why **CROSLEY** RADIO RECEIVERS are so much better

The heart of any receiver is the variable condenser. The superiority of the Crosley book-type variable condenser over the old type interlocking plate air condenser is now generally admitted for the following reasons:

1. Rugged construction that prevents damage.
2. Freedom from short circuits.
3. Permanent metallic contact with plates eliminates sliding contacts.
4. Minimum stray electrostatic field eliminates body effects when tuning.
5. Liberal leakage paths through condenser.
6. Grounded frame provides electrostatic shield.
7. Minimum high frequency resistance or energy loss.
8. Maximum variation in wave length with fixed coil.
9. Maximum mechanical and electrical efficiency.
10. Minimum cost.

We state positively that the substitution of a Crosley condenser for any other type of commercial receiving condenser in any receiving set or circuit will greatly increase the range, volume and simplicity of tuning.

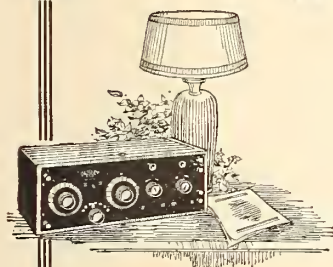
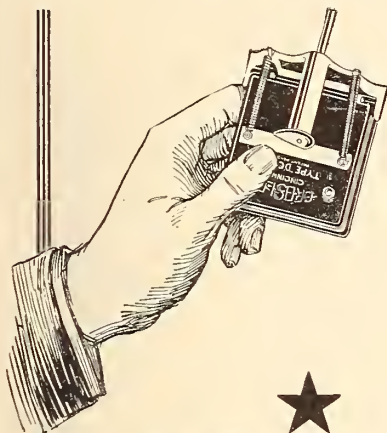

The justly famous Crosley Model VI, a two tube set incorporating one stage of tuned radio frequency amplification and detector, price—\$28.00.

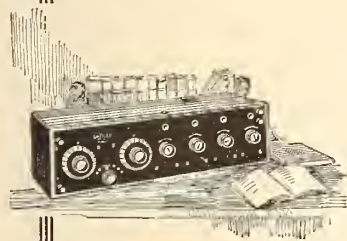

The Standard Model X that has made history during the past year, and is now recognized as the most efficient set on the market, will be continued at the same price, \$55.00, notwithstanding the advanced cost of materials.

We announce a new Model X, to be designated as Model X-J, equipped with head phone jacks for detector and one stage of amplification, in addition to loud speaker binding posts.

The instrument has been redesigned internally with new molded sockets, condensers having molded plates, rheostats in molded shells, new dials, price, \$65.00.

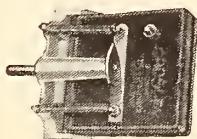

New Crosley type D Condenser has molded plates. Price \$2.25.

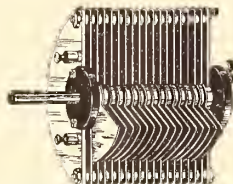

Old-fashioned multiple plate condenser which has been largely replaced by Crosley type D.

New York Office, C. B. Cooper, 1803 Tribune Bldg., 154 Nassau Street

Boston Office, B. H. Smith, 929 Blue Hill Ave., Dorchester

Chicago Office, 1311 Steger Bldg., 28 E. Jackson Blvd., R. A. Stemm, Mgr.

*Crosley receivers incorporating tuned radio frequency amplification reduce static and other interference to a wonderful degree, which greatly increases summer receiving range.*

## CROSLEY MANUFACTURING CO.

720 Alfred Street

Cincinnati, Ohio

# Radio Broadcast

ARTHUR H. LYNCH, EDITOR



## CONTENTS FOR JULY, 1923

"Resolved: That the Volstead Act Should Be Repealed" - - - - -	Frontispiece
THE MARCH OF RADIO - - - - -	179
MAKING RADIO YOUR BUSINESS - - - - -	CARL DREHER 190
USING THE "INVERSE DUPLEX" WITH VARIOUS KINDS OF TUBES	DAVID H. GRIMES 197
RADIO IS EXPENSIVE FOR THE MARRIED MAN - - - -	ROBERT OLIVER 202
PUTTING YOUR PATENT ACROSS- - - - -	ROGER SHERMAN HOAR 205
THE SET THE BOY AND HIS DAD MADE - - - - -	ARTHUR N. KING 210
R. F. AMPLIFICATION WITHOUT DISTORTION OR RERADIATION	EDWARD LINDLEY BOWLES 214
A PORTABLE SET FOR LONELY HOTEL HOURS - - - - -	J. T. N. 219
A MILLIONAIRE'S CRUISE ON AN OPERATOR'S PAY - - - -	A. HENRY 222
A HOME-MADE AMPLIFIER FOR ANY RECEIVER - - - - -	ZEH BOUCK 230
THE "HOW FAR HAVE YOU HEARD?" CONTEST - - - - -	234
WEAF'S NEW HOME - - - - -	239
BOY SCOUTS' RECEIVING CONTEST - - - - -	240
REDUCING THE GUESSWORK IN TUNING - - - - -	J. H. DELLINGER 241
RECENT BROADCASTERS IN NEW YORK STUDIOS - - - - -	246
DRY CELLS AND UV-199's - - - - -	E. E. HORINE 247
WHAT RADIO HOLDS FOR BOY SCOUTS - - - - -	ARTHUR H. LYNCH 251
RADIO BROADCAST CENTRAL - - - - -	PIERRE BOUCHERON 254
THE GRID—QUESTIONS AND ANSWERS - - - - -	256
ADDITIONAL BROADCASTING STATIONS IN THE UNITED STATES - - -	260
NEW EQUIPMENT - - - - -	262
AMONG OUR AUTHORS - - - - -	264

Copyright, 1923, by Doubleday, Page & Co. All rights reserved  
TERMS: \$3.00 a year; single copies 25 cents

F. N. DOUBLEDAY, Pres.

RUSSELL DOUBLEDAY, Sec'y.

ARTHUR W. PAGE, Vice-Pres.

S. A. EVERITT, Treas.

NELSON DOUBLEDAY, Vice-Pres.

JOHN J. HESSIAN, Asst. Treas.

DOUBLEDAY, PAGE & CO.

THE WORLD'S WORK

COUNTRY LIFE

THE GARDEN MAGAZINE

SHORT STORIES

EDUCATIONAL REVIEW

CHICAGO: People's Gas Bldg.

GARDEN CITY, N. Y.

NEW YORK: 120 W. 32nd Street

BOSTON: Tremont Bldg.

LOS ANGELES: Van Nuys Bldg.



PERFECT  
FILAMENT  
CONTROL  
FOR  
**ALL**  
TUBES



- C-300
- C-301
- C-301A
- WD-11
- WD-12
- UV-200
- UV-201
- UV-201-A
- UV-199

# Ask

for the

## Universal Bradleystat

With 3 Terminals

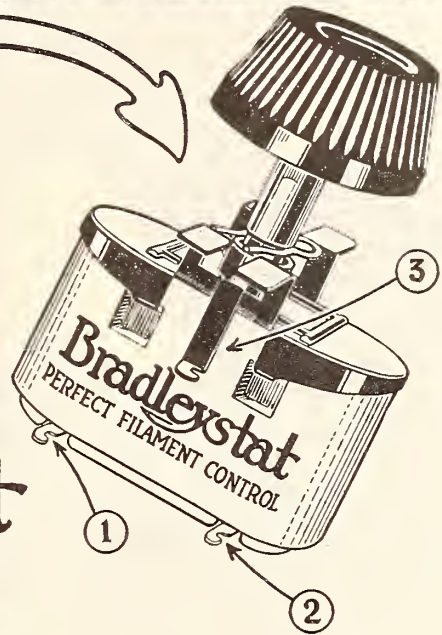

## A Perplexing Problem Solved!

**T**RY any tube in your radio set! It makes no difference what tube is used, the new universal Bradleystat with three terminals will give perfect filament control. A very simple change of connections and a remarkable range of control make this possible for the first time in radio history. Like former Bradleystat models, the new universal Bradleystat with three terminals is covered by the same iron-clad guarantee of perfect performance, noiseless control and quicker tuning that sold hundreds of thousands of Bradleystats during the past year.

Be prepared to try any new tube by replacing your present rheostats with the new universal Bradleystat. It is the last word in flexible and perfect control. It is backed by twenty years' experience with graphite disc rheostats. *Beware of imitations.* Avoid the use of inferior carbon powder rheostats. The name "Bradleystat" is embossed on container for your protection.

*Mail the coupon below for full information about the latest and most remarkable development in filament control. CLIP THE COUPON, NOW!*

ALLEN-BRADLEY CO.    278 Greenfield Ave.    MILWAUKEE, WIS.

I am pleased to hear that the universal Bradleystat with three terminals has solved the perplexing problem of finding one rheostat for all tubes. This is good news. Please send me full information and explain how it is done

---



---



---

★ Tested and approved by RADIO BROADCAST ★





**"RESOLVED, THAT THE VOLSTEAD ACT SHOULD BE REPEALED"**

It is estimated that the debate between Wayne B. Wheeler (right), General Counsel of the Anti-Saloon League, and Ransom H. Gillett (left), General Counsel of the Association against the Prohibition Amendment, broadcasted on April 18th from WEA, New York, was heard by half a million people. This was the first time that two such leaders of opposing thought faced each other before the microphone on a subject of national interest and importance. At the finish of the debate, questions submitted by the audience were answered by the speakers. A poll of WEA's audience showed decisively that Mr. Wheeler won the debate, and that the personal preference of the radio audience on the question, "Should the Volstead Act be Repealed?" was 57% "No" and 43% "Yes"



JUN 20 1923

© C1B579415

# RADIO BROADCAST

Vol. 3 No. 3



July, 1923

## The March of Radio

VOLSTEAD IN THE AIR

**I**N TRYING out the radio public to see what they like and what they don't like, WEA, the well-known station of the American Telephone and Telegraph Company in New York, recently staged a debate on the liquor question: "Resolved, that the Volstead Act Should be Repealed."

This station is continually experimenting with broadcast material, not only with the idea of giving the public varied entertainment, but of enabling those responsible for its operation to gauge the extent of the public's interest in radio and to endeavor to gather reliable statistics as to what kind of programs the public wants. It is evidently in this way only that proper development of radio entertainment can be brought about—only by the tone of the correspondence received can the manager of the station judge of his success in catering to the public's desires. The American Telephone and Telegraph Company is spending many thousands of dollars a year to get the correct answer to the question, "What is the demand for broadcasting?"

The debate on the value of Mr. Volstead's activities was brought about by the Government Club, the President of this organization, Mrs. Geo. E. Owens, having charge of the program, introducing the speakers, and reading the questions sent in by the radio listeners. The public had been told to send in questions as the debate progressed and that their questions would be answered, as far as possible, by

the debaters. The debaters were Wayne B. Wheeler, general counsel of the Anti-saloon League of America, and Ransom H. Gillett, general counsel of the Association Against the Prohibition Amendment. That the question was a live one in which the listeners took an intense interest soon became evident as the questions poured in; only a small fraction of them could be answered in the time allotted.

As we listened to this debate, and pictured the invisible audience of possibly hundreds of thousands, the great utility of radio for political campaigning was once more driven home. The questions asked by the listeners showed thought—showed that the debaters were being closely followed in their arguments by their vast audience. When used by persons aspiring to governmental positions this method of presenting their virtues will prove of real value to those of worth, and should show up at the same time the hollow arguments and fallacies of the familiar political spell-binder. Not only is this scheme of contact between orator and public valuable to the public, allowing them to analyze what the speaker is trying to "put over," but it also has certain advantages for the speaker. It makes him condense his arguments to such a degree that he cannot well remain ignorant of the weak spots and possible fallacies in his speech and it furthermore allows him to proceed uninterrupted to the end. His would-be hecklers must remain silent until he chooses to answer their questions.

### More Injunctions for the Broadcasters

WE NOTED some time ago the action of the American Society of Composers, Authors, and Publishers, in calling on broadcasting stations either to pay royalties for broadcasting music or plays put out under the copyright of its members, or to cease broadcasting such material. We mentioned at the time that the stand of the jazz writers seemed to be somewhat unreasonable in that, whatever their legal rights might be, given to them by our copyright statutes, most of the broadcasting stations were operating as experiments only and were undoubtedly carried by their owners at a considerable loss. When a station can be shown to be on a paying basis then it seems proper for the music writers to collect as their share of the proceeds as much as seems reasonable, but to insist on large royalties while the game is in the experimental stage seems very much like killing the goose which might, some day, lay golden eggs for them.

Our ideas along this line are confirmed by the recent decision of the management of WJZ, the Radio Corporation station at Newark, not to broadcast any more material copyrighted by the members of the complaining society. Thus it seems that the members are certainly going to collect no royalties from the Radio Corporation and it seems, furthermore, that this cor-

poration is one of the very few companies which might show a real, substantial profit as a result of its radio activities.

This company sells a great many receiving sets, realizing no doubt a considerable profit on them, furthermore in the manufacture and sale of tubes the average buyer believes there must be a considerable profit for some one. According to a recent communication from the President of the Radio Corporation, General James G. Harbord, one tube factory alone of the Radio Corporation was turning out 5,000 tubes a day and expected soon to put on the market 10,000 tubes a day. His company had been severely criticised regarding the sudden disappearance from the market of the WD-11 dry-cell tube of the Westinghouse branch of the Radio Corporation; some even went so far as to accuse the company of actually suppressing the sale of these tubes, so that complete sets, in which the tubes were used, could be unloaded on the public. In answering the charge the General made the statement given above, that they would soon be making 10,000 WD-11's a day. If we add to this number a proportionate figure for those made by the General Electric Company, it would seem that the public was buying tubes at the rate of more than a hundred thousand a week!

Is it? If so, it would seem that this company might possibly figure quite a profit from its radio business, but with the American Telephone and Telegraph Company, which as a result of an agreement with the Radio Corporation, sells practically no radio receiving sets or tubes (compared to the numbers estimated above), the situation is different. Their activities in the radio broadcasting field have proved so far a rather expensive proposition, yet they have come to some kind of an agreement with the Society of Composers, Authors, and Publishers, and tell their audience so every time they broadcast—tell it in phraseology which sounds as though it had been specified by counsel for the musicians. We

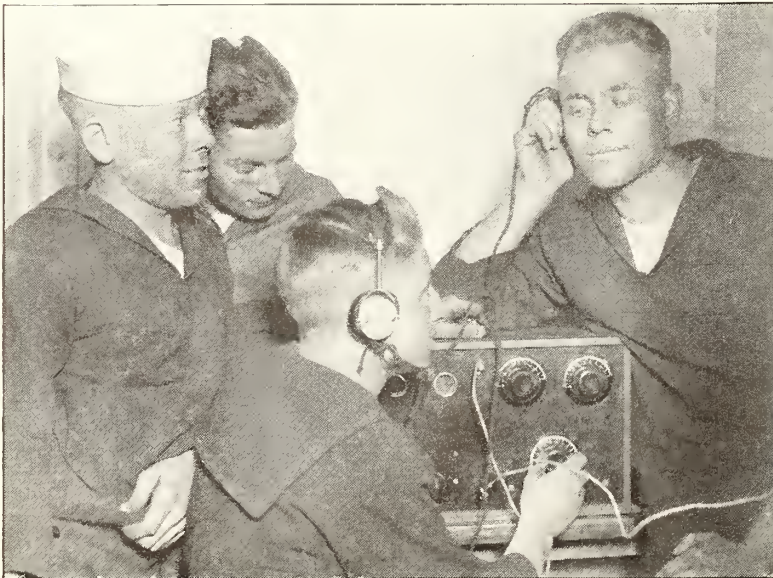

GOB FANS ON THE U. S. S. "MARYLAND"

Many home-made sets are turned out by radio enthusiasts in the Navy. This particular quartet—Arthur Johnson, Thomas Frank, Frank June, and Alvin Munne—are known as the "movie gang," as they operate the movies on the *Maryland*



think the public is rather "fed up" with this society and would enjoy some music without being informed of the copyrighters' existence.

But it seems that WEAFF'S compromise with the S. C. A. P. only leads to more of the same kind of thing; in their efforts to give the public a chance to see how they might enjoy a musical play via radio they arranged to broadcast one directly from a New York theater. This

scheme at once called forth an announcement from Mr. Arthur Hammerstein, in behalf of another society, this time the Producing Managers' Association, in which it is declared that "on behalf of the Producing Managers' Association I wish it to be understood that no music of any opera, musical comedy, or musical play produced by these managers will be permitted to be broadcasted by radio or otherwise without the consent of the Producing Managers' Association. We give notice now that we shall hold to strict accountability any one who shall attempt to produce or broadcast any of our music or any of our works . . . in addition to which we shall attempt to hold, if it is found possible, any violators of our rights under the copyright laws of the country."

So it seems that the path of the broadcast station manager is beset with difficulties—wherever he turns for material he finds the counsel of some body or other confronting him, with bills for royalties in one hand and an injunction in the other. In the meantime the public, the real beneficiaries, get it all for nothing.

### The Electron and its Discoverer

ANYONE who has read even an elementary text on radio has at least a speaking acquaintance with the electron, the minute charge of negative electricity of which there are varying numbers associated with each atom, and to the arrangement and behavior of which is due the apparently complex system of chemical elements. In what way does hydrogen, our lightest element, differ from mercury, one of the heaviest? Only in the number



SIR ARTHUR CONAN DOYLE AND LADY DOYLE AT WJZ

While Lady Doyle broadcasted her views on spiritualism from the Radio Corporation station at Newark, Sir Arthur, known to everyone as the creator of "Sherlock Holmes" and lately come into public attention as one of the foremost investigators in the field of spiritualism, marveled at the potentialities of radio telephony

and arrangement of the electrons around the positive nucleus of the atom. The number of positive charges increases as does the number of electrons with increasing mass of the atom, but the whole behavior and chemical qualities of the various substances seem to be due entirely to the arrangement of the electrons only. In what way does oxygen, the life-sustaining gas, differ from chlorine, the death-dealing gas? Only by the number and arrangement of the electrons in the atom. Can one element be changed to another? By shooting off electrons and positive charges from their atoms the radio-active substances are continually changing from one chemical element to another. Sir Ernest Rutherford has recently shown it possible to "hit" a complex atom with sufficient force to knock it to pieces, the pieces in this case being atoms of other substances. Besides being the active agent in the field of radio, the electron, and its arrangement in the atom, give us the various colors of light, our X-rays, etc.

These same electrons serve to pull trolley cars and subway trains. The electrons in the copper wires of the armature, moving with respect to the electrons in the field windings and magnetic poles of the motor are able, by their concerted action, to develop sufficient force to haul a long train at high speed. It is this same electron which evaporates from the filament of the vacuum tube, and attracted by the positive plate, makes possible the conduction of a current through what is otherwise a vacuum. The electrons oscillating up and down in the antenna of the transmitting station send out waves over their electric fields,



which waves are able to set up corresponding oscillations in the receiving antenna, and thus permit radio communication.

Because of the important part played by the electron in radio, it is fitting to call your attention to the visit to this country of Sir J. J. Thompson of Cambridge University, England, the discoverer of the electron. He has just finished a course of five lectures before the Franklin Institute of Philadelphia, at which all the lectures had to do with some phase of electron activity. Using that keen vision and imagination with which every real scientist must be endowed, he called attention in one of his lectures to the action of an electron held fast to the positive nucleus of the atom, not able to move around as are the electrons which by their motion give the electric current. These rigidly held electrons have certain definite arrangements in which they must fit to make a certain element; if by some means one of these electrons is disturbed from its normal position in the atom it will at once endeavor to fall back into its proper position. As it regains

its proper place in the atom it generally oscillates back and forth about this position, as it "settles down." While the electron is thus oscillating around its proper place in the atom it sends out waves on its electric field just as do the electrons in the antenna of the broadcasting station, but in the cases analyzed by the lecturer the frequency of the vibrations is millions of times as great as the frequencies used in radio transmission; these excessively high frequency waves are the waves of ordinary light or in the case of those much shorter than light waves, X-rays. Thus, says the lecturer, every atom, having its electrons disturbed from their normal positions, acts as a transmitting antenna, while they are settling back into place.

Moreover, different atoms, under like excitation, send out different wavelengths just as different transmitting stations do. Thus an atom of hydrogen, with vibrating electrons, will send off entirely different wavelengths from those of an atom of oxygen or any other chemical element. Whereas our transmitting



"THIS IS STATION BG4"—OF THE 101ST SIGNAL BATTALION, N. Y. N. G.

Located in Herald Square, New York, this field station, type SCR 67A, treats passers-by with music and speech from local broadcasting stations, and also sends out recruiting talks on 200 meters. The receiving apparatus consists of detector and six stages of amplification, affording plenty of "kick" for the loud speaker



antennas send off only one wave, however (if the effect of modulation on frequency is neglected), each atom sends off many waves, but no two atoms, of different substances, send off waves of the same length, so that no interference is caused between the different elements. To detect these different wavelengths the physicist uses a spectrograph instead of a radio receiver; by the reading on his spectrograph he can tell exactly what "atomic broadcasting stations" are operating and thus recognize the presence of different atoms. By this means the physicist knows what substances are on the hot stars, even though they are millions of millions of miles away—a record for long distance reception never to be equalled by the ordinary broadcasting receiver.

Sir Joseph's picture of these "atomic broadcasting stations," transmitting their characteristic waves over distances inconceivably great compared to terrestrial distances, with wavelengths so faithfully maintained at the values assigned to them by Nature that our best measuring instruments, thousands of times as precise as any radio measuring instruments, cannot even detect any departure whatever, cannot but serve as a stimulus and inspiration to our research workers, ever seeking to expand and improve the radio art.

### Wavelength or Frequency?

**A** CHANGE in radio nomenclature is now being advocated by radio engineers and others interested in radio development, which, if adopted, will put into the discard the familiar term "wavelength." In place of this term, which really serves to identify the



SIR JOSEPH THOMSON, DISCOVERER OF THE ELECTRON

On his recent visit to this country, he witnessed the progress which American engineers had made with his theory of electrons, upon which the present development of long-distance radio communication is largely based. His investigations along this line took Sir Joseph Thomson ten years

number of cycles per second of the alternating current at the transmitting station, will be substituted the more logical and reasonable word, frequency, measured in cycles per second.

Radio is nothing but a special branch of communication engineering, itself an important sub-division of the general field of electrical engineering; and as such its language must naturally conform to that of electrical engineering as a whole. Certain specific features of radio communication, being peculiar to radio, and used only by radio engineers and experimenters, may be named in accordance with the



LISTENING TO AN ADDRESS BY GOVERNOR PINCHOT IN ORRSTOWN, PA.

In this rural community, young and old gather in the little school-house to hear the broadcasts received on the set owned and operated by Miss Hannah H. Kieffer, Director of Rural Education in the Cumberland Valley. This receiver, with the power amplifier, is used in twelve different community centres, and has brought in stations from Iowa to Texas and from Canada to Cuba

judgment of those responsible for coining the new words and expressions, but in so far as radio uses ideas and methods in use in other branches of engineering, which have already been named and defined, the nomenclature must be consistent with that already adopted.

It is very easy to see how radio has developed its own language; when Marconi and the other pioneers started to talk and write about their work it was not at all evident that they were engaged in a natural sub-division of engineering. It undoubtedly seemed to them an entirely new art and as such to demand new words and expressions. But as we have studied and experimented in radio, discovered its laws, and found them to be in agreement with those of other branches of electrical engineering, it has become ever more evident that here is simply an addition to the general field of communication engineering and as such it must incline in its language toward that already in vogue among communication engineers.

That the language of radio has changed to a great extent even during its short life of a quarter of a century becomes evident to one

reading the early writings. We wonder how many of our readers know what a "jigger" is and does; to Marconi it was an extremely important piece of apparatus. Does any one nowadays use one of Marconi's "X-stoppers"? Fifteen years ago, Fleming invented the very useful "cymometer", yet we do not often hear it mentioned. Fessenden, in his early and important contributions to the art, employed a "barretter" which he found very sensitive and reliable, compared to other similar apparatus, and Count von Arco's "syntonizer" seemed like a piece of radio equipment destined to become known to every one. We suspect that a large proportion of our readers hardly know what a coherer is, yet it was but a few years ago that every radio worker was endeavoring to improve it. The radio nomenclature of to-day does not know these words of only a few years ago, so it is not at all unlikely that many of our present terms may likewise disappear in a few more years.

One of the most important characteristics of a radio signal is its frequency, that is, the frequency of the alternating current in the antenna of the transmitting station. In the



early days this was known only approximately, but it was always many hundreds of thousands of cycles per second, if not several millions. As the early experimenters, familiar with the electromagnetic theory of Clerk Maxwell, and the experimental verification of the same by Heinrich Hertz, pictured the electromagnetic waves shaken off from their antennas and traveling away in all directions with the velocity of light, it was natural for them to think of wavelengths, as well as frequency, and as the wavelengths, in meters, were generally a few hundreds only, and the frequency hundreds of thousands or more, it naturally became the practice to speak of wavelength in meters rather than of frequency in cycles per second.

As long distance radio developed, and the longer waves proved more suitable than the shorter ones, the frequencies used became lower and lower; thus a 15,000-meter wave used for transatlantic communication, requires in the antenna a current of only 20,000 cycles per second and this is getting well down to the frequencies used every day by the telephone engineer. It seems then, that from this viewpoint alone, it would be advisable to conform to engineering usage and speak of cycles instead of wavelength, unless some serious disadvantage should arise therefrom. Instead of being disadvantageous, however, it will be pointed out later that a marked advantage accrues to the radio engineer by thinking in terms of cycles instead of wavelength.

It will be remarked that the frequencies of the currents used in broadcasting are always several hundred thousand per second, so that apparently inconveniently large numbers would have to be used, such as seven hundred and fifty thousand cycles per second, which is evidently more troublesome than to say a wavelength of four hundred meters. But the term seven hundred and fifty thousand cycles per second will be abbreviated to seven hundred and fifty kilo-cycles; electrical engineers have found it un-

necessary to retain the "per second" part of the term as this is always understood, and the idea of "thousand" is obtained from the prefix "kilo". The engineer interested in transmission lines always speaks of "so many kilo-volts" instead of speaking of thousands of volts. So the four hundred meter wave signal may soon become a seven hundred and fifty kilo-cycle signal and the three hundred meter wave a one thousand kilo-cycle signal, etc.

The advantage of speaking in kilo-cycles, besides putting radio in conformity with the rest of electrical engineering nomenclature, arises from the ideas of "wave bands" used in radio telephony. There the kilo-cycle shows itself much more useful in conveying information than the term wavelength. For the ordinary radio telephone channel there is required a band of frequencies about ten thousand cycles wide, on each side of the carrier frequency. Thus a four hundred meter broadcasting station, using the ordinary method of modulation, requires the exclusive use of frequencies from seven hundred forty to seven hundred sixty kilo-cycles, the carrier frequency being seven hundred fifty kilo-cycles. A neighboring station, sending with a carrier of seven hundred twenty-five kilo-cycles, would require for its exclusive use all frequencies between



AN ENGLISHMAN TELLS THE BEAR FACTS

This diminutive British subject is rebroadcasting to his attentive companion the story of the Three Bears

seven hundred fifteen and seven hundred thirty-five kilo-cycles. With a good receiving set there would be no interference between these two stations, although it would not be advisable to use carrier frequencies so close together for neighboring stations, because the crystal sets, of which there are a good many in use, would be bothered by interference.

Now this frequency band, carrier frequency plus and minus ten thousand, is required *no matter what the wavelength of the carrier may be*, so that in calculating the number of radio telephone channels available in a certain wavelength range the engineer has to change the wavelengths over to frequencies anyway. Moreover when this is done it is much easier to see at once the number of channels available in a given assigned range than it is if the same range is given in wavelengths. *Thus if broadcasting is given a wavelength range of from 220 meters to 550 meters, and amateurs are assigned the 150 to 220 meter band, it seems as though they*

*were getting squeezed into a pretty narrow region, but this is really not the case.* The assignment would give to broadcasting from 545 kilo-cycles to 1360 kilo-cycles, a band of 815 kilo-cycles in which about twenty channels are available. The assignment to the amateur, although apparently much narrower than this actually gives to him a frequency band 640 kilo-cycles wide, almost as many channels thus being available to the amateur as to the wider wavelength assignment for broadcasting. This increase in the number of channels in a given wavelength band as the band moves into the shorter waves is not apparent when speaking in terms of wavelength, but appears at once when the frequency of the current is used to designate the signal instead of the wavelength.

From the foregoing analysis, the advantage of kilo-cycles over wavelength is evident and when it is further remembered that all the instruments used for making radio measurements are really frequency-measuring instru-

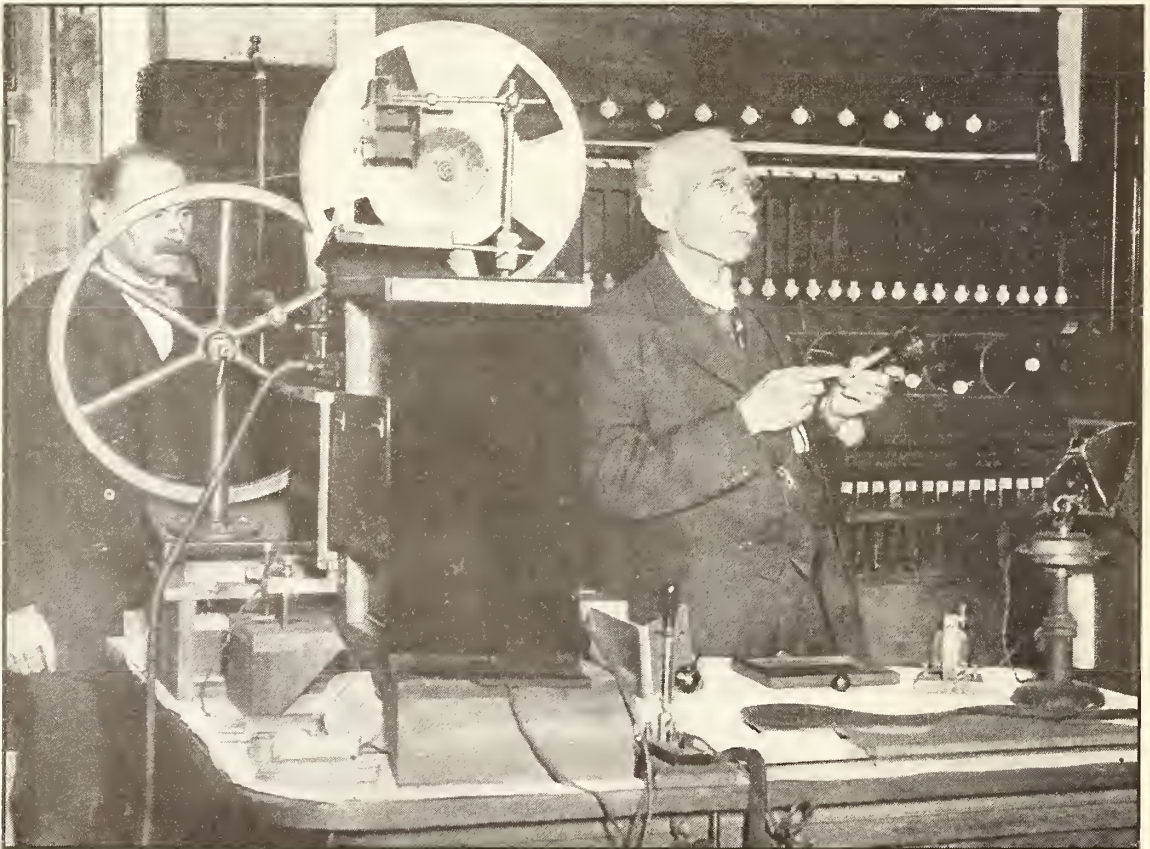

PROFESSOR J. A. FLEMING, F. R. S.

The inventor of the Fleming valve explaining the action of the telephone receiver at one of the lectures he holds for children at the Royal Institution





PUBLIC SCHOOL STUDENTS BROADCASTING THEIR PRIZE COMPOSITIONS

Violet Miller, age 12, of School No. 77, Ridgewood, Long Island, is "on" at WHN, while other budding writers await their turn. School No. 77 is perhaps the first to hold a children's radio forum, an institution which not only stimulates a great interest in the writing of compositions, but gives the children excellent practice in public-speaking

ments rather than wavelength meters as appears from the name "wave meter", and when it is further appreciated that waves do not have their specified length except when they are traveling through free space where there is no absorption, the decision of the radio engineers to use kilo-cycles instead of wavelength is seen to be reasonable and justifiable. Standard works on radio, and technical radio magazines will, for some time at least, print the kilo-cycles per second and wavelength in meters side by side. So it is well to get yourself accustomed to thinking of a station in terms of its kilo-cycles, obtained by dividing three hundred thousand by the wavelength in meters.

#### The Possibility of Re-Broadcasting

IT IS evident to any one who thinks much about the question that in the final solution of the broadcasting problem a given program must be made to reach as large an audience as possible; as the programs of the

broadcasting stations improve, this fact will become increasingly apparent. For example, if an opera is being broadcasted from the Metropolitan Opera House in New York, the artists may be the finest in the world; why then should people in other sections of the country who enjoy opera, have to listen to some mediocre program from a local station? Of course, entirely apart from radio, this is actually the case to-day; we can't all go to the best opera and so we have to content ourselves with something less expensive and less artistic. But right here lies the great promise of radio—it need cost but little more to broadcast to a million listeners than to a thousand, so that the very best programmes should be available to every one.

Some enthusiasts will of course say, "Why worry about the situation? We listen to New York programs every night even though we are more than a thousand miles away." But for every such listener there are a hundred others, potential or actual listeners, who do not re-





SOLDERING TRANSFORMER LEADS—A DELICATE JOB

There are more than one hundred distinct parts used in each of these audio-frequency transformers. No. 40 enameled wire, thinner than a human hair, is used and the task of making uniformly neat soldering jobs with wire as fine as this would be difficult for most people. Not so for Miss Gay Garrity, however

ceive over such distances. The majority will probably always be in this class. Expensive receiving sets, great selectivity and difficult manipulation, are not the factors which make for the popularization of radio, and most of these are required for reliable long distance reception.

The question then arises, How is the multitude to get in contact with the good stations? Two possibilities are being tried out and both of them are likely to be in service before long. The program can be relayed to the various broadcasting stations located throughout the country by either radio or wire. Station KDKA has for some time past been sending out its programs for re-broadcasting in other cities, the transmission between the two stations being carried out on a 100-meter wave. This 100-meter signal is used to actuate the modulator of the second broadcasting station, in Cleveland for example, which then sends out the program on 360 meters. This scheme requires the very best kind of receiving set at the second station in order that the signal may not be unreasonably distorted while being received and amplified for its second transmission.

The second scheme, which seems to us more reasonable, less likely to either receive or give interference, is to send the signal from the first

broadcasting station to the others in the form of audio-frequency currents, over wires. This will undoubtedly be the method of attack of the American Telephone and Telegraph Company as their engineers are experts on speech transmission over wires, and they can carry speech currents over wires almost any distance, with as little distortion as the case may demand. They understand the factors involved sufficiently well to predict, even before a line is put into operation, how good the speech will be; if the amount of permissible distortion is specified, they can design a line and terminal apparatus which will meet the specifications.

In other words here is a problem which can be solved any time the money is available: Telephone transmission is frequently very poor, as every one knows, but the ordinary transmission does not show, by any means, what the engineering staff could do if occasion demanded better, and if the funds were available.

In this scheme, therefore, all broadcasting stations will be connected to a network of telephone lines and cables, and the same audio-frequency signal will modulate all the radio transmitters simultaneously. This scheme does not use up any extra ether channels and should be much less subject to atmospheric and other disturbances than is the radio transmission. Moreover, disturbances on a wire line can generally be eliminated by certain engineering tricks, if the importance of the transmission justifies the expense, whereas but little progress has been made in eliminating static disturbances from the ether channels.

It seems to us that the future of broadcasting is intimately connected with the establishment of a wire network covering the country and connected to the best broadcasting station in a given locality, this wire network to be of the highest quality that the telephone engineer—who has had years of experience in this sort of thing—knows how to build.



## Weather Forecasts

WITH the idea of increasing the utility of the Weather Bureau service, a new broadcasting schedule has been recently put into effect. Every day of the year there will be sent out from the Arlington Naval Radio Station (NAA), on a wavelength of 710 meters, radio telephone weather forecasts and warnings for all the Eastern part of the United States.

In addition to these services, at 10.05 A. M. and 10.05 P. M., an additional forecast will be sent out, at 3.45 P. M., daily except Sundays and holidays, and also on Wednesdays (at 7.45 P. M.) during the growing season, March 15 to Nov. 30, advice will be sent out for farmers and others interested, summing up the effect of the weather for the past week on the progress of the crops.

A feature of this service which provides for dissemination of the weather forecasts immediately after they are issued, is that the announcements are made directly from the Weather Bureau Office in Washington, which is connected by telephone with the transmitting apparatus located at Arlington. The bulletin giving us this information requests that listeners send in suggestions to the Chief of the Weather Bureau, Washington, D. C., stating which service is of most use to them, how the transmission is received, as well as any suggestions regarding the possible improvement in this new branch of government activity.

## An Old Radio Company Changes Hands

ACCORDING to a recent announcement of Mr. Charles Gilbert, President of the De Forest Radio Telephone and Telegraph Company, the control of this company has passed into the hands of certain automobile manufacturers, including E. T. Jewett, of the Paige Motor Car Company, some of the financiers having large interests in the automobile industry, and William H. Priess, the latter having a patent on a certain reflex circuit at present used in some of the De Forest sets. The re-organization will place at the disposal of the company sufficient funds to permit that expansion which the ever-increasing interest in radio receiving seems to warrant. Dr. De Forest has been retained by the new company as consulting engineer, his services being engaged for a period of ten years together with

rights relating to patents he may obtain during that period.

The De Forest company is anticipating a considerable increase in its tube plant. According to Mr. Gilbert, the present plant has a capacity of 1200 tubes a day, but it is expected to increase the number of men employed there from 300 to 600 and so increase the tube output to 2400 a day.

Certain subsidiary De Forest companies, notably those primarily interested in research and development, will continue their work as at present, but the result of their work will undoubtedly be placed at the disposal of the larger company. The phono-film, De Forest's invention in the field of talking movies, is not affected by the transfer as this development has already been taken over by a company formed especially for the purpose. Still another De Forest enterprise, the De Forest Patent Holding Corporation, is exempt from the new agreement, its control remaining as at present.

## An Opportunity

PEOPLE away on a summer vacation are especially susceptible to new ideas, their old prejudices have been left at home and they are quite ready to try anything that looks interesting. They are easily "sold," as witness the high hotel rates for mediocre accommodations and the excessive prices often charged at the novelty stores with which the average summer resort is so richly endowed.

Now, if the Radio Dealers' Association would put into the summer hotel one of their best receiving sets, with the best loud speaker obtainable, we believe many people would become radio converts. Many times the evenings at the smaller resorts are quite dull, and we are sure that a good receiving set would be an attraction which could do real service. It would pay the dealers to install these sets in the hotel for nothing, and maintain them for nothing; the people at the resorts are the kind that have sufficient money to invest in a good receiving set, and they will be excellent "prospects" if the demonstrations are good enough to create the right impression.

There are receiving sets and loud speakers which reproduce music better than the best phonograph.

This looks like a real opportunity to increase the popularity of radio, and we hope the dealers will seize it.

J. H. M.

# Making Radio Your Business

By CARL DREHER

Engineer, Radio Corporation of America

**A**FTER extended observation I am convinced that the rising generation intends to go into professional radio *en masse*. Not only the rising generation, but also many of the generation long since risen. What are the opportunities, they want to know? What sort of jobs are to be had or will be available, what qualifications are necessary, what personal qualities are desirable? Can one become rich as fast as Coal-Oil Johnny, or richer and faster? Shall we train little Oswald to be a radio engineer, or do you think he will be happier as a lard salesman? Will Mr. X, who lost everything he had during the late radio boom, ever regain it? Was it his fault that he went under, or was it Fate? Do all wireless operators rise to \$10,000-a-year jobs? And so on.

Not all of these questions can be readily answered, but it may be useful to attempt the formulation of a list, more or less complete, of the various positions which the individual vaguely known as a "radio man" may fill, and the particular type of character which fits best into each place. In some cases this is a matter of opinion, and while the writer's ideas are based on acquaintance with and observation of a considerable number of radio professionals in active practice, he does not wish to lay down dogmatic rules, nor to have his conclusions swallowed uncritically. It is obvious, however, that the engineer in charge of a broadcasting station, for example, should know a scherzo from a Maltese cat, possess some social ability, and not chew tobacco, while the wireless operator of an oil tanker need not shave more than once in a fortnight, need know nothing about music, and may chew tobacco or even loco weed without hindrance. A particular variety of character make-up, that is, is required for each of these positions, in addition to the difference in technical qualifications.

A very common means of breaking into professional radio is by the operating route. Professional operators are recruited largely from the ranks of the amateurs. Many boys of high school age learn the rudiments of radio

theory at home, running their own sets, then go to a school for a period of about six months, to be taught the somewhat different methods of handling commercial equipment and dispatching traffic. If they qualify for the second grade operator's license they may then be assigned to a ship as junior operators. This is a sort of apprenticeship, for while the second operator stands regular watches, in case of emergency, or if he gets into trouble, he can always rout out the senior radio man, provided the latter is of a not too irascible temper. In time, usually about a year after he thinks that he knows more than the senior operator, the junior may be promoted to the first position on board some other ship, and then, after some years more of marine service, he may be in line for a job at a land station.

## ABOUT GOING TO SEA

**T**HE advantages of the marine operator's life are that he gets to see the world and the ways of other people than those of his native Main Street; that he can save considerable money if he is so inclined; that his migratory existence usually preserves him from getting married too early, and that he has an opportunity to study and to learn the insides, not only of ship-to-shore radio, but the shipping industry in general. In regard to saving money, the average senior operator is paid in the neighborhood of \$100 a month at the present time, and a junior about \$70, plus his lodging and food aboard ship. It is not at all difficult for an operator to lay away \$40-\$70 a month, if he is not too much attracted by the bright lights on his periods of shore leave, and thus in the course of a few years he may amass a capital of several thousand dollars and be in a position to start a small business on shore. The disadvantages are that the hours are irregular and involve night work, and some men find this schedule unhygienic, although the health of the general run of ship operators is probably as good as that of men in other vocations; and that in many cases the man tends to become lazy and to lose his ambition. Ship jobs are of all kinds—on the large transoceanic



liners the telegraphers work almost as hard as the Morse operators on bonus wires ashore, and in fact high speed automatic equipment is being installed on some vessels in this class. On other ships the work is very slack; only a few messages a day are handled, and if the operators are naturally inclined to follow the line of least resistance, such positions are demoralizing.

While some of the foremost executives in radio to-day received their start as operators, it is also true that a man may be industrious, and be an extraordinary operator, and yet show little aptitude for any other position. In such a case he frequently gets into high-power reception, where the particular coördination of ear, eye, and hand at which he has become adept will stand him in good stead. The pay of such men runs about level with that of skilled landline telegraphers in brokers' offices and the like, about \$180 a month, with often a chance to earn more by working overtime.

This is for really fast men who can take 35 words a minute. Contrary to the general impression, a man may be an excellent operator and know little of the mechanics or theory of radio. As in the case of other fields, the work is tending to become more and more specialized, and just as many engineers scarcely know the Continental code, so operators may be found who have less acquaintance with the engineering aspects of the art than some of the enthusiastic laymen in the broadcast reception ranks.

A skilled operator who shows comprehension of the technique of handling traffic—routing of messages, proper coördination with foreign stations, and the like, and who displays some executive ability, may graduate into the ranks of supervisors, chief operators, and superintendents of stations. In these positions a

man must possess technical qualifications enough to enable him to coöperate with engineers, he must know how to keep traffic moving as fast as is consistent with accuracy under various conditions, and he must be familiar with the ordinary methods and principles of business practice. All this requires ability which comes only with years of observation and experience. Not

only is it necessary to know radio, but experience in other lines of communication is also very desirable. The majority of the traffic executives in radio to-day are ex-cable and ex-telegraph men. They know how to coöperate with the older methods of communication, and how to compete with them when expedient. They are not likely to overlook tricks of the wire trade which may be adapted readily to ether communication. The development of radio has in many respects paralleled the growth of wire telegraphy, in, for example, high-speed automatic methods, and

Summer is with us again. Schools and colleges are "letting out" until next September; and many a young fellow is looking for a job of a kind that will be at once a business training, a vacation (at least in the sense of being a change from the winter's work), and a source of income. Comparatively few young men have a strong natural inclination toward one particular kind of work. Often, it is by the merest chance—a scrap of information that appeals to the imagination, a lack of interest in certain other fields, or some unaccountable and illogical prejudice—which lands a fellow in a job in which he is destined to make a distinct success.

A boy's hobby often leads to a man's business. How many young radio enthusiasts of to-day will be in one way or another connected with the radio game when they grow older? Thousands—that is certain. For them, and for other thousands who may have only a vague idea, or none at all, that their life work may be concerned with radio, this article of Mr. Dreher's will have a strong appeal.—THE EDITOR.

the history of radio invention is in part a process of adaption from cable and wire technique with, of course, many innovations and novel expedients. Likewise the men at the very top of radio communication, particularly in its high-power international aspects, are largely former executives of wire telegraph companies. Accordingly, if a man wants to become a real expert in radio telegraphy, it might be good advice to tell him to start with a cable company, just as a few years of telephone experience are a sizable asset for a specialist in radio broadcasting.

#### THE TRAFFIC MAN

THE traffic or operating man must always be prepared to think and act quickly, as an inherent requisite in his field. He has under his charge expensive machinery and elab-



GEORGE LEWIS—ONE OF THE "OLD-TIMERS"

He has been actively interested in radio since 1908—possesses the first commercial operator's license issued by the U. S.—was in charge of field radio design for the Signal Corps in 1910—designed the first high-power military radio tractor and the first tuned-circuit transmitter, making air-craft transmission possible—was in charge of radio design division at the Navy Department during the War—organized and was first executive secretary of the National Radio Chamber of Commerce—and is at present with the Crosley Mfg. Co. as assistant to Mr. Crosley. He has traveled widely in this country, Europe, and the Orient, and is well known in radio circles here and abroad. As a recreation from work, Mr. Lewis writes poetry, plays golf, and enlarges his collection of artistic camera studies.

orate circuits which must be utilized to the fullest possible extent. The case is the same whether the operating man has charge of a broadcasting station, or is pounding the key in a ship's cabin, or has charge of a transoceanic station. In the broadcasting station one cannot afford to keep either the performers or the radio audience waiting. Marine radio conditions in congested districts are like the New York subways during the rush hour. There are always four or five ships lined up waiting to unload their messages. The land station gives its "Go ahead" signal to a ship, and the ship is expected to be there with its answer with a speed somewhat exceeding that of a faculty procession. In a transoceanic station the payroll and the investment are very high

and delays eat up the profits. The design and research people know occasional periods of leisure, but the operating man's job is often an uninterrupted rush; at least his ability to hold it is dependent on his ability to get things done fast at certain times. Thus if one has aspirations in the way of making a living in the radio field and one's natural tendency is to work slowly, however thoroughly and dependably, the best thing is to keep away from the operating end of the game.

Of course a man who gets dizzy on the deck of an auto bus *may* develop into a successful steeplejack—but the chances are against him.

#### RADIO ENGINEERS

RADIO engineers fall into three classes: operating, designing, and research. Of course these categories overlap, and a competent engineer will not be lost in changing from one function to another. The operating engineer, as the term indicates, is concerned with actual handling of equipment. In this class, therefore, would fall the technical staffs of broadcasting stations, and the men who handle the machinery of high-power wireless telegraph circuits. The designing engineer, somewhat farther in the background, takes care of the layout of apparatus and its adaptation to specific uses. Farthest removed is the research worker, whose business it is to anticipate the needs of the future and to develop new and improved methods of transmission and reception.

What has been said above about the character qualifications of the operating man in general applies in every particular to the operating engineer. He must be quick in thought and execution and not easily rattled in emergencies. He must know how to coöperate with people who are not interested in and usually have little understanding of his problems, without letting the attendant difficulties get on his nerves. If he is a telegraph man, his contact will be with traffic officials and operators with little or moderate technical training and an overwhelming desire to get things running immediately, if not sooner, and to keep them running all the time, if not longer. The technical man may be nursing along a 200-kilowatt alternator out at some high-power station, and when the local lighting company drops the supply voltage a few notches he may have to ask the traffic people for time out to retune. In ten minutes the voltage comes back to



normal, and the job has to be done all over again. It takes only a few minutes, but to the traffic man, staggering under a load of urgent messages, those minutes are very precious. Or, at a receiving station, signals may be weak at times, and one has to explain why less high speed is being handled than last July.

Again, at a broadcasting station, the operator is the connecting link between the performer and the audience; neither must be kept waiting, and any interest they manifest in the technical features and difficulties is of necessity

very casual. If a reactor breaks down in the plate circuit during a concert, and the set begins to go glug-glug-glug in the middle of *Caro Nome*, who will pity the poor broadcast operator or speak of him charitably on the commuters' express the next morning? Such an accident simply mustn't happen. And it rarely does. It is surprising, considering the newness of radio and the complexity of transmitting equipment, how rare and brief the interruptions are. But if this is so, it is not by any special dispensation of Providence, but by foresight, provision against weaknesses, ample safety margins, and unceasing observation and striving for improvement on the part of the men who design and run the sets.

The designing engineer converts ideas which have been found to work, into operable apparatus. The research engineer tries to dig up ideas which will work. They must work, of course, not only in the laboratory, but in the field. Hence the research worker requires a physical sense which will restrain and guide him in his search for new methods. Lacking this, his tendency will be to turn out plans for intricate and unstable apparatus which no amount of capable designing will save from the scrap-heap. At the same time he is usually a more imaginative individual than his colleagues in the other branches of the art, and his work is more closely allied to that of the artist or the pure scientist. He is frequently better versed in fundamental theory than the other classes of engineers; he must be, in fact, in order to be in a position to utilize the work of the pure scientists and mathematicians. It is

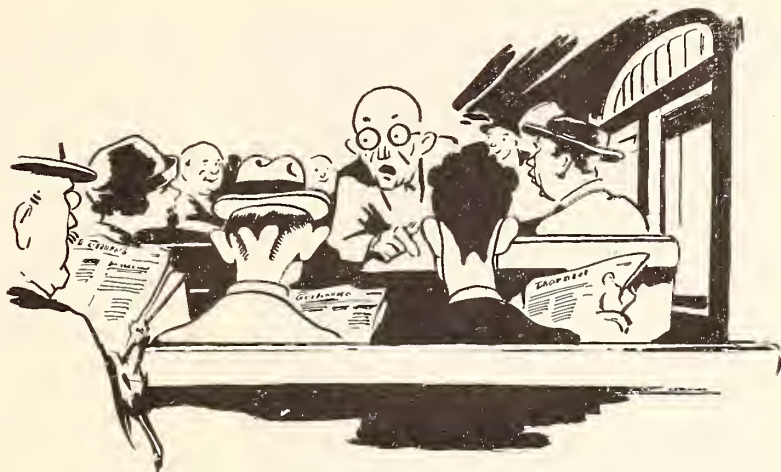

WHO WILL PITY THE POOR BROADCAST OPERATOR  
Or speak of him charitably on the commuters' express the next morning?

with the latter that novel ideas usually, though by no means always, originate. Thus we have an Oliver Heaviside investigating the properties of electrical lines and cables, and putting his conclusions into forbidding mathematical form, and a few decades later a Pupin digesting Heaviside's formulations, drawing practical conclusions, and ultimately producing the methods of inductance loading, which, with the development of the vacuum-tube amplifier, have made transcontinental telephony possible. The research engineer is thus on the second rung of the ladder which leads from ideas, more or less in the abstract, to concrete machinery operable by fallible human beings. A man well endowed with scientific curiosity, who wishes to work in an atmosphere of quiet and orderly pursuit of knowledge without regard to the vexatious details of practical application, is best off in academic research. With somewhat the same bent, but a little less zeal for reducing all ideas to a clearly expressed physical basis, and more tendency to turn out something which can be fitted into the complex machinery of industry, he may make a good industrial research man. Given still less preoccupation with ideas as such, and the type of mind which does not shrink from minutia—whether to use a 6-32 or an 8-32 machine screw, or how thick to make a panel, or how many turns of wire to use in a coil—always with an eye to the greatest durability and efficiency at the least expense, we have the material for a designing engineer. Of course, as in other fields, a capable man knows a lot about one thing and a good deal about everything

else. A first class designing engineer, for example, will be familiar with the outstanding ideas, at least, of men like Clerk Maxwell, Hertz, and Heaviside; he will have original ideas for improvements in the art and be at home in a laboratory; he will have the command of detail and knowledge of materials and manufacturing methods enabling him to draw up plans for efficient apparatus, and in a pinch he will be able to operate an actual station.

#### OTHER OPPORTUNITIES

**M**ANY other branches of technology might be mentioned in this outline of the varying functions of the radio engineer. The test shops, for example, have turned out some of the leading technicians in the field. In a test shop one learns, as in no other place, the method of operating, kinks, and limitations of

apparatus. Not only that, but one gains an assurance in handling apparatus which is hardly obtainable elsewhere. In a test shop an engineer gets his baptism of fire.

In one test shop where I worked it was the fashion to thumb one's nose at a short circuit arc immediately, if one retained the power of movement after the accident; no other reflex was considered *comme il faut*. Not that short circuits are welcome, but they occur in electrical practice, and in a test shop one learns not to be disconcerted when the fireworks start. And there are many tricks, such as the preliminary jerking in and out of the switch at the first test of a piece of apparatus, which form part of the equipment of a good electrician and save a great deal of money in the long run. There is no other place like a test room for learning these tricks.

#### RADIO DEGREES?

**P**EOPLE new to the field are sometimes influenced by the aggregations of letters which some of the experts and writers put after their names. Most of these mean about as much as the title of "Professor" prefixed to the name of instructors in boxing or the gentry who teach you to play the piccolo in four lessons. As yet no institution of good academic standing has established any such degree as "R. E.," for example, and, although a man putting these letters after his name may be a capable worker, they merely represent his own idea of himself and should be taken with the same reserve as advertisements in general. A certain discrimination should also be exercised in the matter of the weight given to membership in engineering societies. These organizations play an important rôle and everyone of consequence belongs to them, but it is not generally known that for an associate membership the only qualifications are interest—not necessarily competence—in the art, conventionally good business morals, and the ability to spend five or ten dollars a year for dues. For the higher grades—member or fellow,—some four and seven years of actual engineering experience are requisite, and to that extent membership in these grades has some bearing on the standing of the engineer in question. Holding of office in the societies, present or past, is of course an indication that the individual is respected by his colleagues and may be taken as safe evidence of high professional standing. Similarly, technical degrees from

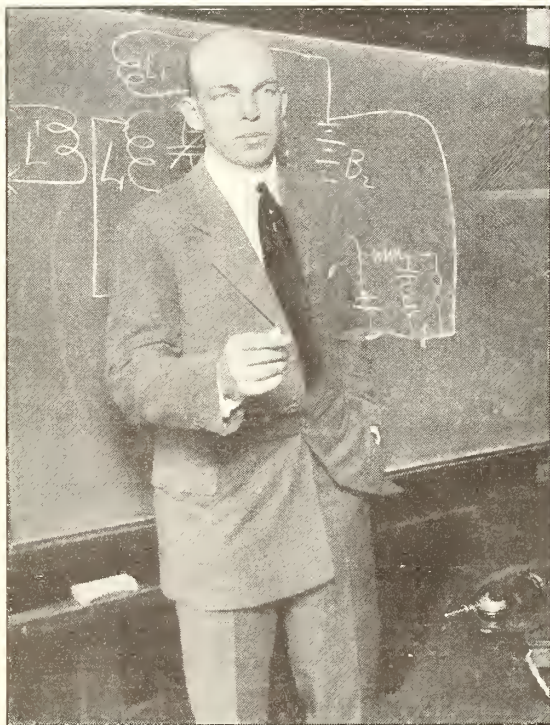

© and courtesy of Hearst's International Magazine

#### HE MADE RADIO HIS BUSINESS

Edwin H. Armstrong has been responsible, within the past ten years, for three of the most important radio developments. Before the War, he invented regeneration, which makes long-distance reception possible with a minimum of equipment. During the War, he devised a system of reception called the super-heterodyne, used at the time for intercepting enemy messages on very short wavelengths and now becoming popular for long-distance broadcast reception. Last year he disclosed his most recent invention—super-regeneration. Among the apparently unlimited possibilities of this form of reception is long-distance work with a single-tube loop set



universities of good standing, or study under acknowledged authorities, may reasonably be taken into account.

#### THE RADIO BUSINESS

THE business side of radio is hardly within the scope of this article; success is here a matter of general business acumen, plus special knowledge of the field and its particular patent and commercial difficulties. Broadcasting has of course changed the entire aspect of things in radio. It is only necessary to consider the case of one manufacturer whose experience dated back to the very earliest days of radio in the United States, and who maintained his business tolerably well in the spark-set years, and then, after almost two decades of moderate prosperity, failed when he tried to swing an ambitious program in manufacturing broadcast equipment. Apparently with the greater opportunities of the radio telephone boom he did not sense the instability of the new market, the necessity of meeting severe competition, and the adjustments required in manufacturing for a new class of users. So he went to the wall just as fast as any newcomer. In radio, as elsewhere, people who try to become millionaires in haste repent at leisure.

#### THE BROADCASTING GAME

BROADCASTING has opened up a considerable number of new positions. The personnel of a first-class station may include a program manager, who interviews prospective artists and makes arrangements for out-of-the-studio broadcasting, several announcers, and a technical staff, consisting of control operators, transmitter attendants, and outside or pick-up men. The control operator monitors the outgoing material and makes indicated adjustments, such as increasing or decreasing the amount of modulation, setting the accompaniment at the proper loudness relative to the singer, and so on. The transmitter operator watches the tube set, checking the wavelength and antenna current, and listening in at short intervals for distress signals at sea, which necessitate immediate shutting down of the transmitter. The outside men take care of acoustic exploration at theatres and halls from which special-event broadcasting is contemplated, the setting of the microphones, necessary tests, and supervision during the actual transmission. Of course in most stations there is not as much specialization as this,



© Underwood & Underwood

#### HE HAS HAD A FINGER IN MANY RADIO PIES

Elmer E. Bucher, born in Akron, Ohio, in 1885, and educated at the Academy in Oberlin, Ohio, joined the De Forest Wireless Telegraph Company as experimental engineer in 1903. Later, he was active as construction and installation engineer, organizer of radio schools, inventor, and radio editor and author. His "Practical Wireless Telegraphy" is the best-known of his many books on radio. He is at present managing the sale of amateur and broadcast equipment for the Radio Corporation of America

and one man may handle most of the routine of the studio. As soon as one gets into outside work, however, a good-sized staff becomes imperative.

An ear for music and sensitiveness to cacophonous elements are among the special qualifications of the broadcasting station operator. The more he knows about the engineering end—the special features of tube set operation, the technique of electrical voice reproduction, and so on—the better, but in addition to these fundamental factors he must be something of a musician and expert in practical acoustics. If he lacks these qualities, he will often be in the position of knowing less about the mechanics of his job than the performers in the studio, many of whom have had experience in the closely related field of phonograph recording. Social qualities are also of more importance in the broadcasting field than in other branches of the art, since the personnel of a station is in contact with outsiders of prominent position and good breeding. The broadcasting specialist, accordingly, has to try to make himself a combination concert hall manager and engineer. This question of general cultivation and social ease is likewise prominent in the selection of announcers.



←  
HE CAME, HE SAW, HE BECAME A  
RADIO MAN

At the age of sixteen, David Sarnoff persuaded the superintendent of the Marconi Company that he was the "Boy wanted." He soon became an operator, then manager of the Sea Gate station, then sailed to the Arctic as wireless operator on a sealing vessel. Returning, he enrolled as student in electrical engineering at the Pratt Institute night school, in Brooklyn. His next position was that of Inspector, then Chief Inspector for the Marconi Company. In September, 1922—at the age of 32—he was elected Vice-President and General Manager of the Radio Corporation. He is the man who, eleven years ago, received the message in New York, from the S. S. *Olympic*, 1,400 miles at sea, giving first confirmation of the sinking of the *Titanic*



→  
FRANK M. SQUIRE, OF THE DE FOREST CO.

Starting in radio as an amateur, he entered the game professionally in the draughting end. He worked with the A. H. Grebe Company as draughtsman, and finally as Chief Engineer. Later, he organized the Radiocraft Company, of which he is now President, in addition to being Chief Engineer of the De Forest Company. His outstanding contribution to broadcast reception goes by the name of the De Forest D7-A Reflex Receiver

The writer has had occasion recently to give counsel on the matter of taking up radio as a profession to several young men of high school age, and an outline of his recommendations may be of interest to readers in somewhat the same position. The first desirable step is to get into practical touch with the field through amateur activities—reading the periodical literature, building sets, joining radio clubs and becoming junior members of the engineering societies. It is best to go to a college or technical school, specializing in electrical engineering—not that a B. S. or an E. E., as such, makes an engineer of a man, but it affords him a good foundation, enables him to make pleasant and valuable personal connections, and gives him, in later years, the satisfaction of feeling that he has not overlooked any good bets in preparation. This point is emphasized, it should be added, by associates of the writer for whom he has the highest respect, and who, lacking academic preparation, feel nevertheless that the time and capital is advantageously invested. Dur-

ing vacations, if it is at all practicable, the student should try to obtain temporary employment in commercial operating, as an apprentice or junior, or factory experience, less for the income obtainable in this way than for the value of coördinating practice and theory. Attention should be devoted to code practice and a commercial operator's license secured as soon as possible. Although radio's centre of mass may be shifting from telegraphy to telephony, the relations between the two will of necessity remain intimate; operators of broadcasting stations, for example, are required to have commercial telegraphers' licenses at the present time. On the other hand, it is clear from what has been said above that courses in the arts, such as a study of the history of music; and such experience as may be obtained in playing in a college orchestra, for example, will be quite valuable, even looking at the question from a narrow utilitarian viewpoint, without regard to humanizing and cultural influences.

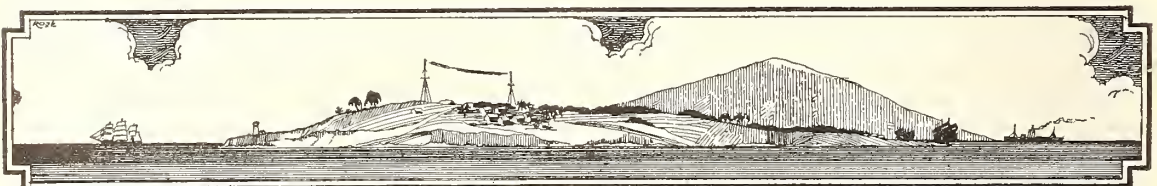



# Using the "Inverse Duplex" with Various Kinds of Tubes

By DAVID H. CRIMES

This article, written by the inventor of the Inverse Duplex circuit, discusses, from the standpoint of practical operation, the hook-up of which the theory was explained by Mr. Charles H. Durkee in the April number.

Since that first article appeared, we have been deluged with letters, some hundreds of them, asking every imaginable question about the theory, construction, and operation of the Inverse Duplex. The present article has been written by Mr. Grimes at our request, to answer many of the questions that have been asked by correspondents, and to let others know something of the possibilities of this circuit.

Briefly, the Inverse Duplex is a method of employing tubes for radio and audio-frequency work *simultaneously*, without overloading them—the heaviest audio-frequency currents flowing in the tube where the weakest radio-frequency current is flowing.—THE EDITOR.

**S**INCE the publication, in RADIO BROADCAST, of some of the details of the Inverse Duplex receiver<sup>1</sup> there must have been, conservatively speaking, at least two million questions asked concerning various parts of the circuit.

As a result of the much appreciated cor-

respondence, I have learned several things concerning the operation of the hook-up which would otherwise have taken me several years! And it is the purpose of this article to give the radio fan at large some of the benefits which I have received individually from him.

As with all new developments, there are many things which have to be known by the enthusiast before he can successfully dupli-

<sup>1</sup>"1,300 Miles on a One-Foot Loop," by Charles H. Durkee, April, 1923.

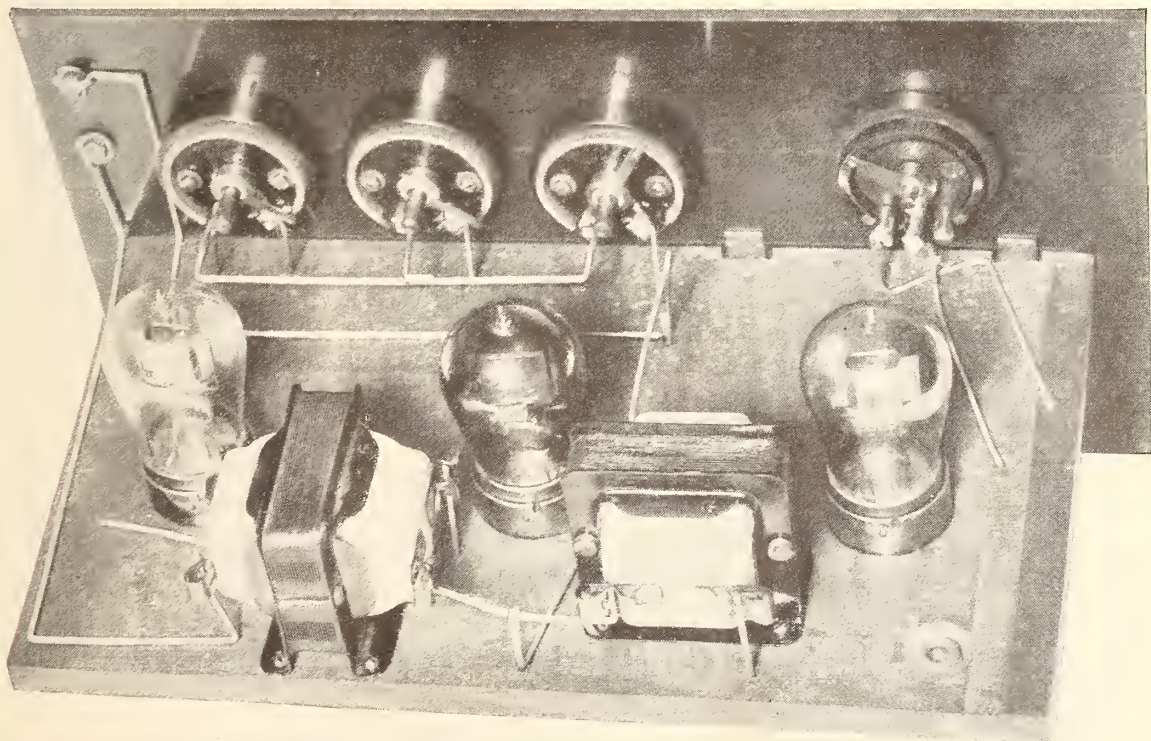

THE LAYOUT FOR THE AUDIO-FREQUENCY PART OF THE INVERSE DUPLEX



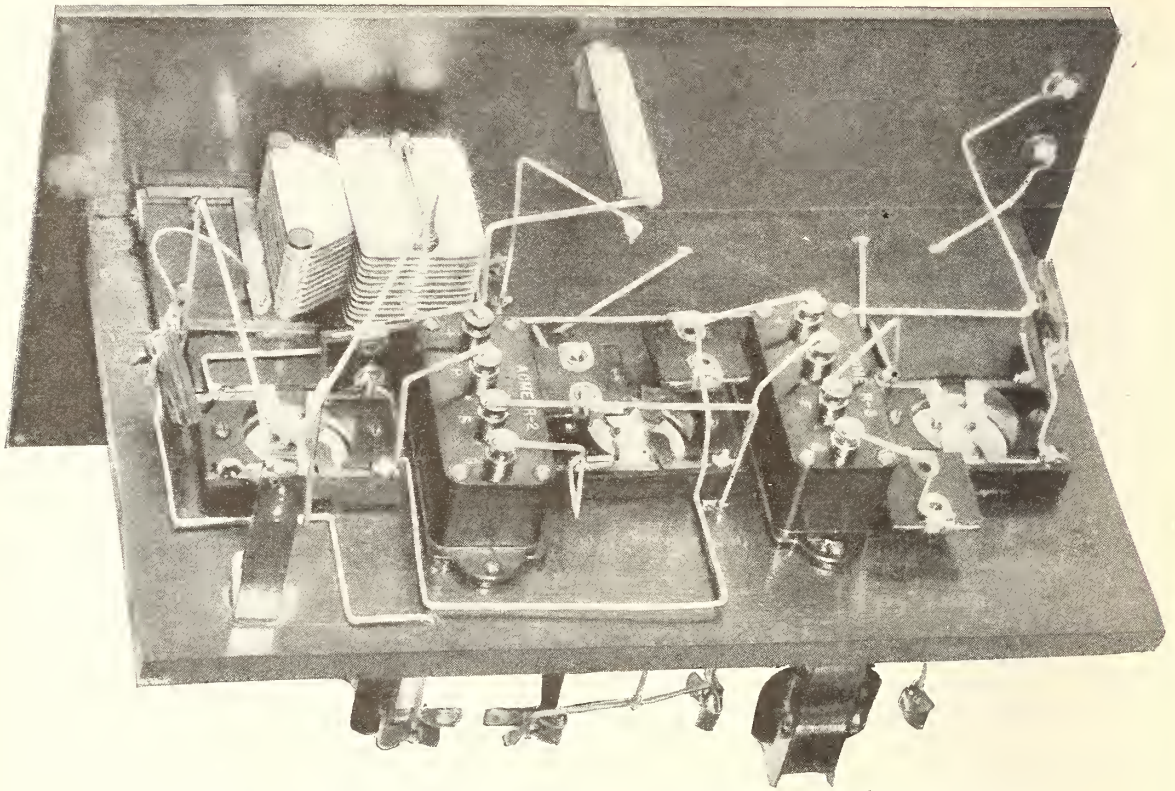

BOTTOM VIEW SHOWING RADIO-FREQUENCY ASSEMBLY FOR THE 3-TUBE CIRCUIT

cate the Inverse Duplex, even though he thoroughly understands the principle. Such supposedly simple details as equipment assembly, method of wiring, types of tubes, voltage of batteries, etc., immediately take on immense importance.

The circuit details disclosed in the April number of RADIO BROADCAST were necessarily applicable to only one type of apparatus, especially the tubes, as the purpose of that article was to outline theory, rather than practice. With the advantage of the theory fairly well appreciated, it may be of interest to you to learn what has been found *best in practice*, by myself and others.

Most of the troubles encountered in the operation of the Inverse Duplex arise from the radio frequency part of the circuit. If you have had little or no experience with radio frequency circuits, the following suggestions will prove helpful to you. All leads from the radio transformers to the grids, plates and bypassing condensers should be as short as it is possible to make them. These wires are carrying high frequency alternating currents and if run near other wires or apparatus they are

likely to "cross over" into them through the capacity between them, just as they do between the plates of a condenser. This will cause no end of trouble. The photograph showing the equipment layout indicates the closeness of the radio transformers and tubes.

Next, radio frequency amplification, unless properly designed, has a tendency to oscillate or howl and to the novice with little experience, it is almost impossible to stop it. This is mostly a problem of radio transformer construction, but even with a given transformer which tends to oscillate, there are several tricks which may be employed to stabilize it.

Radio transformers have to be pretty carefully built, and even then are best suited to certain types of vacuum tubes. Some transformers which are absolutely successful on, say, the Radiotron tubes, are very poor on any other type of tube. It is impossible, generally speaking, to use indiscriminately any type of vacuum tube with any type of radio transformer. Therefore, in purchasing your tubes and R. F. transformers, be certain that they are of a design suitable for operation with each other.



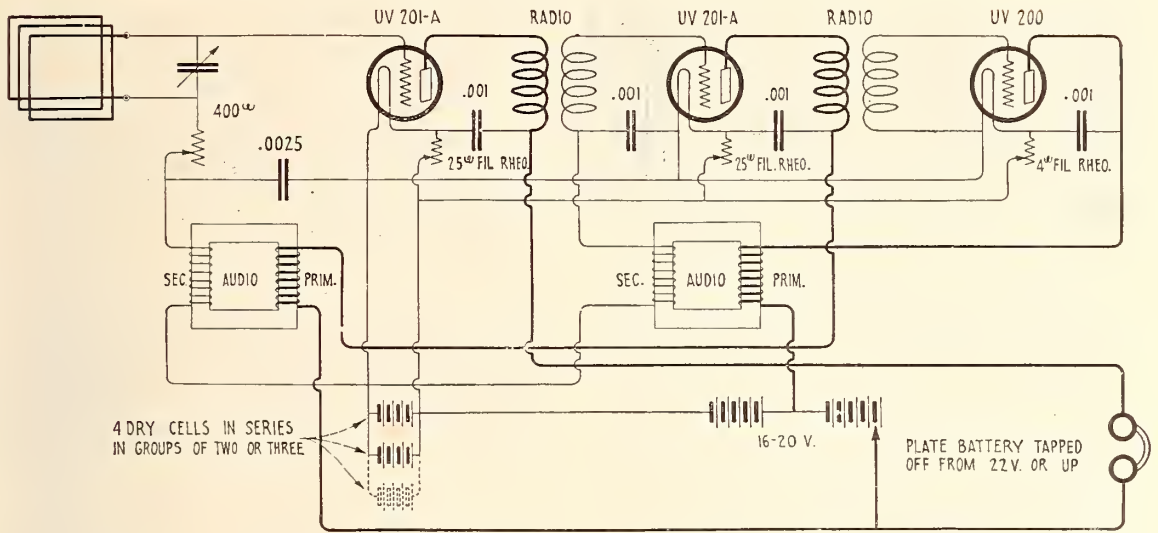

FIG. 1. HOW TO EMPLOY A UV-200 AND TWO 201-A'S

25-ohm rheostats are used for the 201-A's, and the common 4 to 6-ohm rheostat controls the UV-200. Dry cells in series-parallel are used to light the filaments

BEGIN AT THE BEGINNING

THE best possible way to proceed in wiring up an Inverse Duplex circuit is to connect up merely the two stages of radio and a detector to start with. If no results are obtained on this, it is useless to expect anything by adding the two stages of audio. The audio stages function to make louder the results already obtained by the detector tube. Hence it is absolutely necessary to secure results there before proceeding further.

One of the features of the Inverse Duplex circuit is the easy and ready way in which trouble may be located. The hook-up can be cut into three separate and distinct circuits—the radio, detector, and audio connections. Any one of these three may not be operating properly due to troubles common to radio circuits, detector circuits, or audio circuits.

For instance, on loop reception, it is somewhat difficult to make a so-called "hard" tube, such as the UV-201, act properly as a detector on only two stages of radio. On the

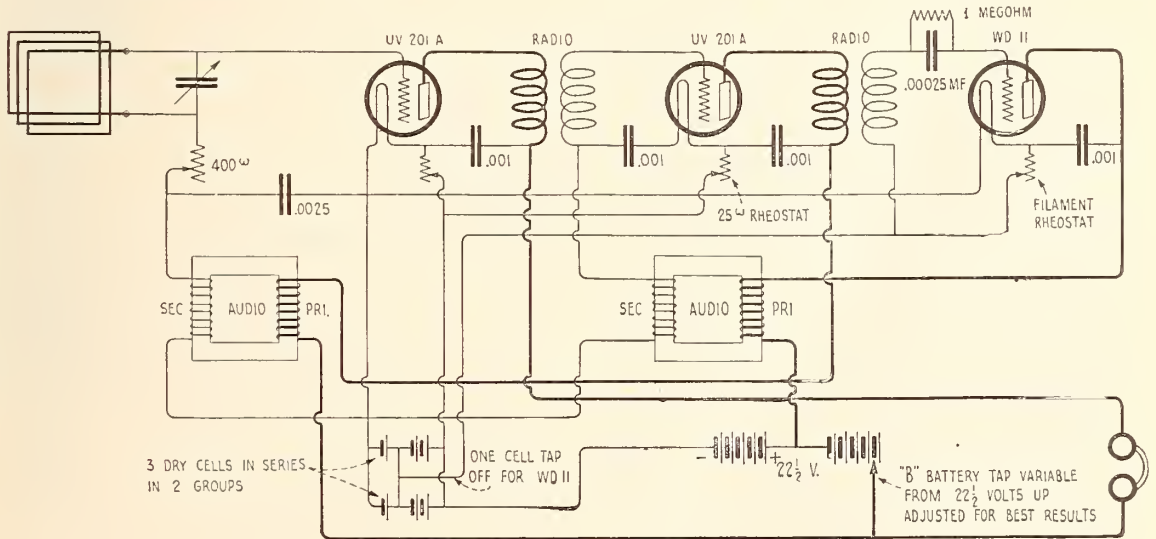

FIG. 2. THE SAME CIRCUIT ADAPTED FOR USE WITH A WD-11 OR WD-12

Note the 1 1/2-volt tap-off for detector-tube filament

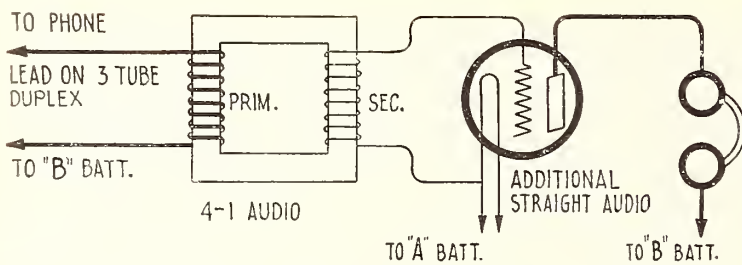

FIG. 3.  
SHOWING HOW TO ADD A STAGE  
OF STRAIGHT AUDIO TO THE IN-  
VERSE DUPLEX

other hand, a "soft" tube such as the UV-200 will do this easily. There are detectors and detectors, varying over all known ranges of sensitivity. A great deal will depend, naturally, on the sensitivity of your detector for best results. The April article recommended a UV-200 tube as a detector. This tube does not require a grid condenser or leak and the grid wire should lead back to the negative side of the filament. A UV-201 or 201-A tube is not recommended here for a detector.

#### USING DRY CELL TUBES

THIS brings up the dry-cell situation as applying to my circuit. The same thing holds true in this case. When satisfactory radio amplification is obtained and successful detection is secured, the rest is easy. The new UV-201-A tubes which will operate on low enough currents to permit their use with dry cells, cause considerable difficulty in radio circuits unless special precautions are taken. I have found that the easiest way to secure stability with these tubes on radio frequency is to drop the plate voltage to 45 volts and sometimes even lower. Dropping the filament voltage below 5 volts often helps.

For a detector tube on dry cell operation, the UV-200 can hardly be recommended because of the high filament current required. It is possible to use it but several banks of dry cells must be connected in parallel to hold up for any length of time. The expense of such operation becomes greater than the maintenance of storage batteries and is not advisable. The UV-201-A tubes have, in my experience, not responded as detectors to weak enough signals to permit their use with only two stages of radio on a loop. The WD-11 is apparently much better but requires a different line-up in the filament battery circuits. It operates on only about 1 volt while the UV-201-A tubes function on from 4 to 5 volts.

Many questions have arisen regarding the omission of the filament rheostats on the

amplifying tubes in earlier drawings. These were purposely left out because the UV-201 tubes would take the battery voltage (about  $5\frac{1}{2}$  volts after the filament current had gone through the battery leads) directly, with only a small decrease in their life. It was thought that omitting these rheostats would simplify the adjustment of the set to a sufficient degree to compensate for the somewhat shorter life of the tubes. The confusion, however, has been so great that I am now suggesting that the amplifying tubes have rheostats inserted as shown in the accompanying diagrams (Figs. 1, 2, and 5).

Having assumed, now, that the radio frequency part of your circuit has been adjusted to function satisfactorily, we are ready to consider the specific difficulties encountered in duplexing the audio on the radio tubes. Most fans have little or no trouble with audio circuits, or if they have, they have learned how to overcome them, by reversing the primary windings, etc. The reversing of leads on the primaries of the radio transformers, by the way, is a good thing to try when troubled with instability in the radio frequency circuit.

You will no doubt recall what was said in the April issue about overloading the tubes in certain types of "reflex" circuits. It was also brought out that the Inverse Duplex greatly helped in overcoming this trouble by balancing the load. Even then, if the incoming energy is excessive, as is the case on aerial reception for local work, the carrying limit of the tubes is reached and poor quality results. In this case, the 400-ohm resistance would not be sufficient to cut the energy down to a reasonable amount. WD-11 tubes are not very satisfactory as amplifiers in this circuit as they are limited in energy and are easily overloaded. This circuit is essentially a super-sensitive layout and will not stand tremendous currents. If louder reception is desired on local or long distance stations than that given by two stages of audio, it is suggested that an



additional tube of straight audio be added between the set and the reproducer. The sole purpose of this tube will be audio amplification and can be used to the limit of its ability for that purpose. If greater range is desired, a straight radio stage may be connected between the loop and the first duplex tube, but, of course, this has a tendency to overload the duplex tubes on local reception. Running three duplex tubes beside the detector is not to be recommended to the uninitiated, although it has worked out perfectly in hundreds of cases during the past year. Until the amateur has fully familiarized himself with the duplex peculiarities on two amplifier tubes, he should not tackle the three-amplifier layout.

#### ANY LOOP WILL DO

A ONE-FOOT loop was referred to in the previous article and this has led to much confusion. Many readers inferred that the circuit would operate with nothing else. Any kind of a loop will work on the circuit provided the number of turns are such as to tune properly with the variable condenser for the wave lengths desired. The smaller the loop, the less energy it will pick up and the less will be the range for a given sensitivity of circuit. Many other types of sets have operated over considerable distances on loops ranging all the way up to 5 feet on a side or even larger. The one-foot loop was emphasized merely to illustrate the extreme sensitivity of the circuit. On powerful stations up to 175 miles away, I

have obtained good reception on a 4-inch coil—the secondary of a variocoupler. For best all-round results, a 16- to 20-inch loop with 8 to 12 turns of wire, spaced  $\frac{1}{4}$  inch apart is suggested. On a three-foot loop, a listener in New York using the Inverse Duplex circuit with two tubes and a crystal detector, has picked up stations as far west as Kansas, at noon. This size loop has a tendency to overload the circuit on night reception. Overloading is easily ascertained by poor quality or the first or second amplifying tube acting as a detector instead of the regular detector tube.

#### TWO WAYS OF OVERCOMING "SILENCE"

AFTER all the above suggestions have been followed, there will be cases, no doubt, where the fan will still have trouble. There are so many variables which can cause trouble. I would recommend trying two additional changes which ordinarily are not desirable. The first is to run the grids of both amplifying tubes back to potentiometers instead of to the negative filament, and the second is to cut down or perhaps eliminate entirely the bypassing condensers on the middle tube. This first gives broad tuning and also reduces the audio, while the second materially reduces the range.

The audio transformers should be of the  $3\frac{1}{2}$  or 4 to 1 ratio preferably. Under certain conditions, especially when using a crystal for a detector, the first audio transformer after the detector can be of the high, or 10 to 1, ratio.

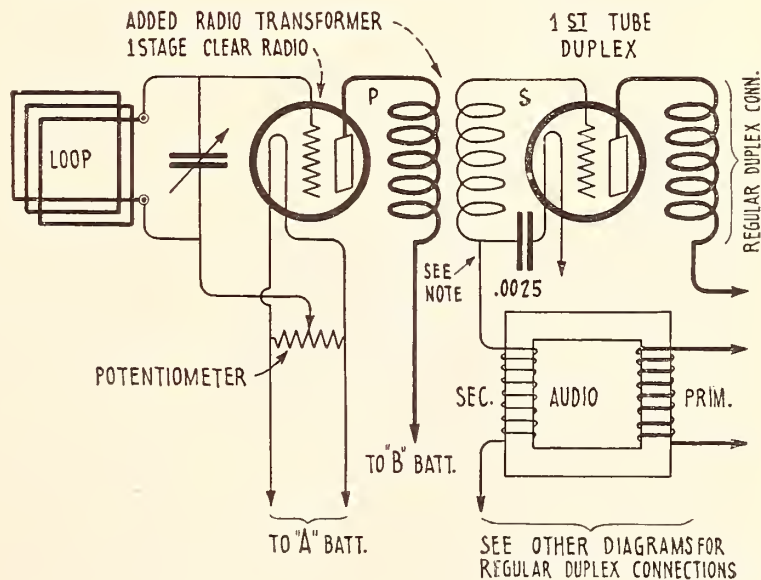

FIG. 4.

HOW TO ADD ONE STAGE OF STRAIGHT "RADIO" TO THE INVERSE DUPLEX

Where UV-201-A tubes are used, 25-ohm rheostats should be connected in series with the filaments. The same thing applies to the arrangement shown in Fig. 3

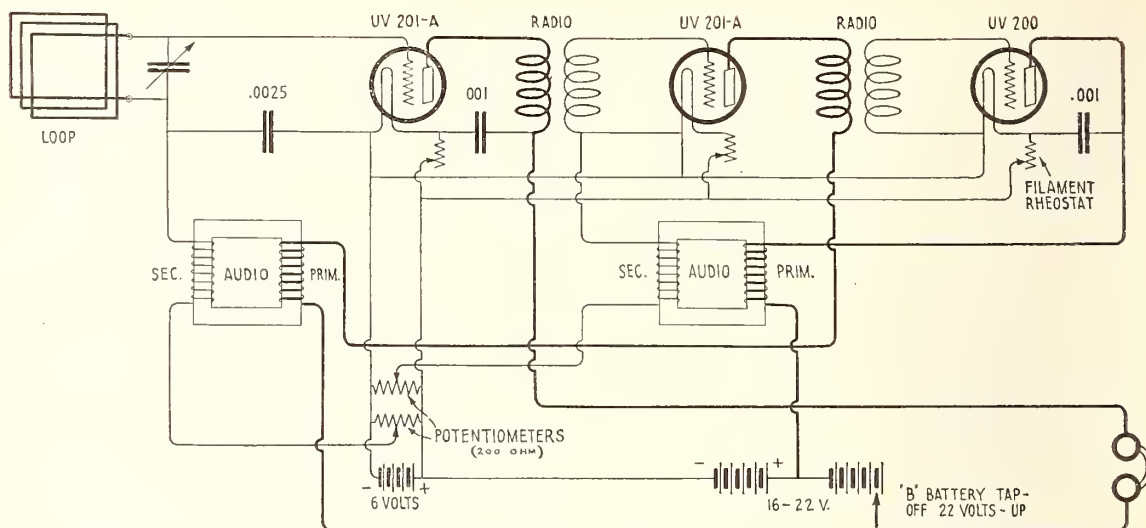

FIG. 5. THE STABILITY OF THE CIRCUIT IS IMPROVED BY TWO 200-OHM POTENTIOMETERS

Note that in this case there is no by-pass condenser on the second tube

It is assumed that the ordinary troubles possible in radio hook-ups, such as open transformers, poor tubes, broken down condensers and run down B batteries, have been located and eliminated. It is naturally beyond the scope of this article to cover all these points, but nevertheless they must first be checked before any success can be obtained. Fully nine out of ten troubles which I have been personally called to remedy were due to such things as mentioned above.

If I have in any small degree helped the radio fan along, I shall feel amply repaid, and to those who have not achieved all the results they had a right to expect, I can only suggest that they accept the advice on the back of one of the earlier automobile handbooks: after all the cures for possible automobile troubles have been given throughout a vast number of pages, the final statement is made, "Don't forget that this machine once worked, and with proper care will work again."

## Radio is Expensive for the Married Man

By ROBERT OLIVER

**R**ADIO, relatively speaking, is not very expensive when indulged in by a single man, but when a married man succumbs, it is different. Not, as you may have hastily concluded, because the places where radio apparatus is exposed for sale make a practice of jumping a married man harder than they do the bachelor, but because of one item in the total cost which is submerged.

If you are a married man, and, like many another, goaded to a point where you feel like an outsider amid the jargon of radio fans, you

may decide to investigate and perhaps invest. But listen. There is one item that belongs on the list of what to buy that you never can dodge.

This item belongs in the class of things that you can not say with words. Florists advise saying it with flowers.

If one could get by with flowers it wouldn't be bad. But flowers don't seem to suffice. One man I know had to get his wife a new car and teach her to drive it. Thus, when he came home at night with his arms full of parts he could pretty safely bank on his wife's being out with the car.



Take my friend Jennings. Before the radio mania seized him, he was as keen a conservator of the old savings account as one could wish to meet. Now Jennings has a one-man radio factory going full blast in his basement, but the price he pays for it is terrible. His wife has an ermine cape and has already priced certain articles of jewelry involving platinum.

Possibly the prospective married radio enthusiast who has an idea that a couple of hours will be sufficient to put together a set may pause when he learns that radio takes time. It takes time to shop around for apparatus. It takes time to read radio magazines. One must read the radio advertisements. One must study all the new hook-ups and figure out the weekly, one might say daily, batch of super circuits.

As for any one particular hook-up, its days are as grass: as a flower of the field, so it flourisheth; for the wind-of-something-new passeth over it, and it is gone; and the place thereof shall know it no more.

Take the radio fan's Sunday. Almost any Sunday will do. His routine is something like this.

7:00 A. M. The fan wakes up and wonders if a C battery wouldn't help his second step. He resolves to try it and gets so interested in the idea that he can't go back to sleep.

7:15. Gets up and turns off the current on his battery rectifier.

7:25. Fixes furnace and makes a side trip to work-bench. Inspects new set he is working on. Finds a couple of loose connections.

7:30. Lights laundry stove to heat soldering iron. While soldering iron is heating, decides to substitute bus bar for bell wire in connections from filament.

8:00. Remembers that rheostat for first step makes poor contact, decides it is good time to take it out and put in new one bought yesterday.

9:00. Wife calls breakfast. Soldering iron poised in midair. "Can't stop just now dearie, be there in a minute." Finishes soldering, puts tools away and discovers two loose taps on inductance. Better fix it while iron is hot. Iron is cold, so lights gas and waits for iron to heat.

9:30. Taps all fixed, tears himself away, shaves and dresses. Comes down to breakfast. Wife and breakfast cool.

10:00. Goes down to fix furnace again. Makes another side trip to work-bench.

Starts tracing out grid and plate circuits. Finds grid leak connections very loose. Better solder them. Lights gas and waits for soldering iron to heat.

11:00. While iron is heating decides to put some spaghetti on plus A lead to prevent getting it crossed with 90-volt B which is bad for tubes.

11:30. Too late to go to church. Wife gone to church. "Oh well, 'sall right. Get a little time to myself now." Starts laying out some radio frequency.

12:30. Still laying out radio frequency. Decides to get another radio freak transformer to-morrow. Saw one advertised in magazine.

1:00. Mess call. "Just a moment dear, can't come just now. Be there in a minute."

1:30. Responds to mess call. Wife and mess decidedly cold.

2:00. Mess over. Not a very chatty meal.

2:15. Decides it might be a good plan to "say it with an automobile ride." Skies brighten a bit at suggestion. Goes down to



"CAN'T STOP JUST NOW, DEARIE, BE THERE IN A MINUTE"



"I'VE BEEN THINKING,  
MY DEAR  
That you need a rest. How  
would a trip to California strike  
you?"

fix furnace. Makes side trip to bench to see if everything is all right. Everything not all right. Left gas burning and soldering iron is red hot.

2:20. Decides to solder a couple of connections while iron is hot.

2:45. Still soldering. Can't make 'em stick. Too big a hurry. Gets sore and hot.

3:00. Still soldering. Hears noise upstairs. "All right dear, be there in a moment."

4:00. Goes up. Finds wife gone out. Noise was door slamming. "Oh, all right. It'll gimme a little time to myself. Gosh, women are unreasonable."

4:10. Goes down to work-bench, now that he has a little time to himself, and works on radio-frequency hook-up. Decides to drill new panel bought yesterday.

5:00. Panel all drilled. Might as well mount condenser and rheostats now that he has a little time to himself.

6:30. "Gosh how time flies." Wonder if the wife has returned. Wife still out. "'Sall right, now I've got a little time to myself."

8:00. Wife returns. Brrr!

8:15. Hooks up set and listens in. Gets sermon entitled "One Day of Rest in Seven."

8:16. Decides to try to get distant

stations. Local stations too strong.

8:30. Quits and goes down to fix furnace. Wishes radio-frequency hook-up was finished. Better go and look over radio-frequency hook-up. Makes side trip to work-bench.

10:00. Still working on radio frequency. Glances hurriedly at watch. Wow—10 o'clock already!

11:00. Prepares "temporary" hook-up of radio frequency. Tries it. Doesn't work. Takes it back to basement. Decides to put in condensers on transformers.

12:00. All set again and ready to try. Local stations silent. Doesn't work. Goes over hook-up plans again. Remembers article in magazine on radio frequency.

12:30. Funny where that magazine went. Goes back

and tries radio-frequency hook-up again. It works but not very well.

1:00. Decides to quit and call it a day.

Gentle reader, perhaps you begin to gather the importance of doing something to thaw out the frigidity resulting from such a schedule. The only way is to search out some of the wife's repressed desires. See if she hasn't a complex centering around a trip to California. Every woman has such a complex, something that comes to the surface every now and then, under stress.

Decide upon the particular complex that makes its presence known most frequently. Then, with casualness, not to betray the hidden motive, say something like this: "I've been thinking, my dear, that you really need a rest. I can't get away myself, but how would a trip to California strike you?"

Try to find the California trip complex if possible. It is really much better than a fur or diamond complex. I'll tell you why. Although furs and diamonds are more enduring and in times of great stress may be hypothesized, perhaps, still there are advantages about a California trip for the wife which should not be overlooked—by the fan who wants a little time to himself.



# Putting Your Patent Across

How to Choose Your Lawyer. A Word About Foreign Patents. Some Popular Illusions Mercifully Destroyed

By ROGER SHERMAN HOAR, A. B., M. A., LL. B.

Former Assistant Attorney General of Massachusetts

**T**O MOST inventors, the patent law seems a maze of complications. It seems complicated merely because everything unknown is mysterious.

But as soon as its principles are separated from technical terms and from the usual hocus-pocus with which some lawyers are fond of mystifying their clients, it becomes a lucid subject, easily understood.

On the other hand, everything about which you have a smattering of knowledge seems easier than it really is.

Now, it is possible for any intelligent inventor to handle his own case from start to finish, by following the book of rules issued by the Patent Office. In some instances it may be desirable for you to handle your own case, as for instance when you are filing your application merely for the purpose of saving the expense of a "search," or for the purpose of ascertaining what some competitor may have up his sleeve.

But, in general, "a man who is his own lawyer has a fool for a client." Did you ever notice, in reading the newspapers, that whenever a lawyer gets into trouble, he does not try to handle his own case, but rather hires the most able and expensive brother lawyer whom he can find. If lawyers, who know all the shortcomings of their own profession from the inside, and who are much more able to handle their own cases than any layman could possibly be, nevertheless consider it advisable to employ an attorney, how much more advisable is it for a layman to do likewise! To show that I practice what I preach, I will state that at present I have three applications of my own pending at Washington, and that each of them is in the hands of an attorney other than myself.

Since April, when this series of articles started in RADIO BROADCAST, I have been deluged by letters from readers, and a large proportion of these have been from inventors inquiring as to how to choose a patent attorney.

A great many inventors are perplexed by the apparent *impasse* created by the fact that the only way to find a lawyer is by his advertisement, and that reputable lawyers do not advertise. Although it is true that the ethics of the profession do not permit lawyers in general to advertise, yet, in the first place, it is not unethical to use an advertisement merely stating one's name, one's address, one's phone number, and the fact that one is a lawyer, specializing in certain sorts of cases; and, in the second place, the rule against advertising has been considerably relaxed in the case of patent lawyers, for they are not in as good a position to get business by other means as are general practitioners.

So don't worry about whether your lawyer advertises or not, for plenty of reputable patent lawyers do advertise. But be sure and give heed to what he claims in his advertisements. And especially avoid lawyers who guarantee results, for the mere fact that he can get you a patent on your invention means practically nothing. You may have a perfectly wonderful invention, and yet secure an absolutely valueless patent based on it, especially if you employ a guaranteeing attorney.

There's nothing wonderful in being able to guarantee results! It is the simplest thing in the world to secure a patent! I, here and now, will guarantee to get any one a valid patent on anything under the sun, new or old, provided only that it has some detail, however slight, to distinguish it from the prior art; but this is not particularly clever of me, for any other attorney could do the same. We would not, however, promise that the patent would be worth the paper it was printed on.

Closely akin to the patent attorneys who guarantee results are those who *impliedly* guarantee results by making their fee contingent upon success. What do they mean, "success"? Contingent fees are proper, and even desirable, in certain fields of the law, notably personal injury suits and will-contests, for

in such cases the client can ill afford to pay a cent if he loses, but can well afford to pay a quarter, or a third, or even a half, of his total recovery, if he wins. Even in such cases, there is a temptation for the lawyer to make a quick settlement for the certainty of a small fee, rather than to do the extra work necessary to secure a larger recovery. But, be that as it may, there is *no* excuse for a contingent fee in any situation where it is impossible to measure accurately the value of the results.

The third class of lawyers to avoid are those who charge a uniform fee, regardless of the amount of work involved. It stands to reason that they will give just as much attention, and no more, to the case, than is necessary to secure some sort of a patent.

It is hard to say which is the worst: guaranteed results, contingent fees, or uniform charges, for they all are akin.

If you are interested merely in getting *a* patent on your invention, then by all means go to such an attorney. But if you want a patent carefully drawn, so as to secure you the maximum protection against infringement, consistent with the state of the prior art, within the allowable range of equivalents of the elements of your invention, then you should avoid a shyster lawyer as you would avoid a quack doctor. Go to the best firm you can afford, and be prepared to pay them well, on a time basis, regardless of results.

It is not necessary that your lawyer be an expert in your particular field, for lawyers are notably adaptable. At the Coast Artillery School during the War, some statistics were compiled to show the relation between previous education and standing in War studies, the object being to induce highly trained technical men to choose the Artillery branch. The figures came out just as expected, with one startling exception; or rather, addition. The lowest grades were those of grammar-schooling or less. Then came the high school graduates. Then the college graduates. Then the holders of advanced degrees: M.A. and Ph.D. in mathematics, Civil Engineer, Mechanical Engineer, Electrical Engineer, etc. But, far in advance of all, in a group sufficiently large to show that it did not exist by mere chance, stood the holders of the LL.B. So, in order not to spoil the statistics, the Army authorities lumped the lawyers in with the engineers, under the head of "and other advanced degrees."

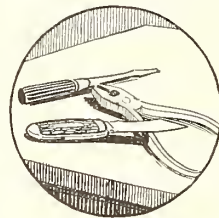

This episode shows us that the law-trained man is, by nature, so adaptable that it is easier for the average lawyer, with no technical experience at all, to master a branch of engineering, than it is for an engineer to switch from one branch of engineering to another. So don't worry about your lawyer's ignorance of your particular line.

It is much more important for a lawyer to understand judicial psychology (i. e., the mental processes of his courts), than it is for him to be versed in the law; so, all other things being equal, choose a former Patent Office examiner to handle your applications. But, if possible, choose one who has been graduated from a law school of standing, as otherwise you are not getting a really law-trained man.

For searches, choose an expert in this line of work. Several former Commissioners and Chief Examiners have made conspicuous reputations in this field.

For foreign patents, there are firms who do nothing else, having their representatives in every country in the world. Most local patent attorneys are totally unfitted for this work; but you should have your American lawyer cooperate with your firm of international lawyers.

For drawing assignments and similar papers, a general practitioner is preferable to a patent lawyer, as such papers are governed by the general, rather than by the patent, law.

For court-work, choose a good trial lawyer, who understands the psychology of the particular judge before whom the case is to be tried, but have your patent attorney sit in with him. Some of the best patent-trial lawyers in the country have never handled a single patent application, and some of the most skillful claim-drafters have never appeared in court.

When a person wishes to buy or sell a patent, the thought naturally occurs to him to secure an abstract of title from the Patent Office, just as one does from the Registry of Deeds when dealing with real estate. But there is a great difference. In the case of real estate, a bona fide purchaser cannot be affected by a deed which has not been recorded; but in the case of patents, unrecorded papers frequently spoil the entire title.

Interests in patents can be vested in assignees, in guarantees of exclusive territorial rights, in mortgagees, and in licensees.



An assignment conveys the whole interest of the patentee, or an undivided part thereof, extending throughout the whole United States.

A grant conveys exclusive rights under the patent throughout some specified part of the country.

The meaning of "mortgage" is well known.

A licensee is one who takes an interest less than or different from any of the aforementioned. A license may be oral, written or printed, and if written or printed must be duly signed. In the absence of words to the contrary, a license is personal to the licensee, and cannot be transferred.

Assignments, grants, mortgages, and possibly exclusive licenses, must be written or printed, must identify the patent by date and number (or, if the invention be unpatented, must give the name of the inventor, the filing date and the serial number, if any), must be duly signed and acknowledged before a notary or similar official, and must be recorded in the Patent Office within three months of execution, or at least prior to the execution of any subsequent purchase or mortgage, in order to be valid as against such subsequent purchase or mortgage. It is said that the subsequent purchaser or mortgagee has "constructive notice" of the recorded conveyance. Actual notice by the purchaser or mortgagee, prior to his acquiring title, is equally effective to invalidate the subsequent purchase or mortgage.

And now, I suppose, you would like to know something about foreign patents. Obviously the subject can merely be sketched in the brief space that remains to me; so let us call this merely an *introduction* to foreign patents.

If you decide to patent abroad, you will wish "to get in under the Convention"; i. e., to file abroad within one year of the filing date

of your American application. The Convention is a treaty between most of the civilized countries of the globe, whereby an inventor will not be penalized because of the publication or use of his invention within a period of 12 months from the filing of his first patent application. Under the Convention, an applicant is safeguarded for one year from the date of filing his first patent application; and, so long as he files foreign applications (in the countries party to the Convention) within 12 months from the date of filing his first case, his foreign applications will be immune from attack on the ground of any publication or use of the invention that may have taken place in the interim.

In the United States the date of conception of the invention is what counts, but in practically all foreign countries the applicant must stand or fall by his filing date. Thus in most foreign countries, a published description or public use of an invention prior to the filing of an applica-

tion will forever prevent a patent, unless the inventor gets in under the Convention. In some of these countries the publication must be local, but in others a foreign publication will bar.

In case you do not wish patent protection abroad, but merely wish the field left clear for yourself, you can prevent others from obtaining a valid patent on your invention, by publishing a description thereof in the countries in question. This description should be full enough to enable any skilled person to duplicate the device.

In considering the foreign field, bear in mind that if no publication or use has taken place, a valid patent can be obtained; but that otherwise a valid patent is possible only under the Convention. An invalid patent, however, is better than none.

According to Mr. Hoar, most people are possessed of a number of erroneous ideas regarding patent law and procedure. In this article, he sets you right, with a jolt, perhaps, but with no less shrewdness and accuracy on that account.

Until you have read this article, you may be under the impression:

That sale is the only sort of infringement. This is not the case.

That an inventor can continue to manufacture his own invention after selling his patent. Not so.

That joint owners must split fifty-fifty. No such thing.

That it is wise to hire a patent lawyer on a contingent fee basis.

Quite the contrary.

It is very agreeable to have some of the prevailing "mysteries" of the patent game clearly exposed and explained. We commend this article, and the three in the series which precede it (April-June, 1923), to all our readers who have even the slightest glimmer in the back of their minds of an idea which might some day be developed into an invention worth patenting.—THE EDITOR.

The cost of patent proceedings varies greatly in foreign countries, and is complicated by the cost of translations, patent taxes and "workings," none of which exist in America. Of course, different firms charge different amounts, but the following represents a fair average.

Translation, one dollar per hundred words in most countries, but running as high as three-fifty in some. Drawings, five or ten dollars a sheet. Fees and legal services, from forty to two hundred dollars, depending on the country.

In most countries, patents are subject to an annual tax, usually starting either immediately on filing, or immediately on issuance, or a few years thereafter, and gradually increasing during the life of the patent. Non-payment forfeits the patent. In some countries, there is merely an extension fee required, once in the case of 14-year patents, or twice in the case of 20-year patents. A few, notably Canada and some Latin American countries, have no tax.

In nearly all foreign countries, no search, or at most a mere perfunctory examination, is made by the patent office. The patent is advertised, and if no objection is filed within a certain period of time, it issues as a matter of course. But Canada, Germany, and Great Britain proceed by office-action and amendment, very much as does the United States. Some countries, in the case of applications under the Convention, require the filing of copies of all American actions and amendments.

In nearly all foreign countries, the patentee must, within a certain number of years, commence the local manufacture of his invention on a sufficient scale to satisfy the local demand; as otherwise the patent will become void. This is called "working." But in some of these countries, a "nominal working" will do. This consists in advertising for someone to build your invention, and then in the rare eventuality of someone taking you up, making your terms too hard for him. Or in some countries, it is sufficient to mark your patent "license of right," which means that you will license any one who applies. This may sound dangerous; but in Canada, out of all the hundreds of patents so marked, only one such license has ever been required.

Some countries, notably Canada, prohibit the importation of the patented article by the

patentee, under penalty of forfeiture of his patent. But the law is usually satisfied by Canadian manufacture of the parts vital to the patented feature, American manufacture of the rest, and assembly in Canada. Similar acts will also satisfy the working requirements of most countries.

In many British colonies, a British patent can be registered at any time during its life, and thereby becomes effective locally for the rest of its duration. A similar rule exists in certain Danish and United States colonies. But in a very few British colonies, local use or publication will bar filing. And in another very few, use abroad by others than the inventor will bar filing.

The life of a foreign patent varies from five years in some countries to twenty-one years in others, the prevailing period being fourteen or fifteen years.

I strongly advise any inventor against foreign patents, unless he is backed by a corporation sufficiently affluent, pugnacious, and liberal to defend his rights, or unless the invention is epoch-making (which, unfortunately, most inventors consider all their "brain-children" to be). For it is a comparatively simple matter for a determined local competitor to upset the patent of an absentee.

A large part of these articles has consisted in the puncturing of popular fallacies. Therefore what more appropriate way is there for concluding the series than to give a list of deadly parallels setting forth each of the prevailing misconceptions; and, in contrast to each, the truth. This list will follow as closely as possible the order of the preceding text, to which the reader can refer for more detailed enlightenment.\*

The deadly parallels are:

1. That the ownership of a valid patent is a guaranty of your right to manufacture the patented article. On the contrary, you are more than likely to be barred by at least one earlier patent.
2. That sale is the only sort of infringement. On the contrary, manufacture is infringement, and use, even by an innocent purchaser of a machine, may also infringe.
3. That no damages can be collected for an

\*The three preceding articles in this series of four, are: "What Good is a Patent?" in the April number; "What Can Be Patented?" in the May number; and "Protecting Your Invention", last month.





infringement which doesn't make money. On the contrary, the patentee can collect three times what *he* would have made, if you had not taken away his trade.

4. That use purely for amusement is not infringement. On the contrary, it is infringement, if the device is an amusement device.

5. That, if you invent something first, no subsequent inventor can prevent you from using your own invention. On the contrary, he may quite likely obtain a patent which will be held valid, in spite of proof of your earlier conception, and thus may enjoin you from using your own device.

6. That joint owners of a patent cannot act alone. On the contrary, any one of them can issue a valid license under their patent.

7. That joint owners must split fifty-fifty. On the contrary, neither of two co-owners is responsible to the other, in the absence of an express agreement.

8. That the invention of a technical employee, invented in the course of his employment, belongs to his employer. On the contrary, there are many situations in which it does not, even though the invention is applicable to the employer's business.

9. That it is a harmless courtesy to include your helper or your boss as a joint inventor. On the contrary, this may invalidate your patent.

10. That an assignment of all future inventions is void, unless it contains a time limit. On the contrary, a limit as to subject matter is equally effective.

11. That an inventor can continue to manufacture his own invention, even after selling his patent. On the contrary, a patent, once sold, is *gone* forever.

12. That there is some magic in having the inventor's first drawing bear the signatures of *two* witnesses and be attested by a notary. On the contrary, the real requirement is the assurance that at least one outsider has understood the invention on the date in question, and will so testify convincingly in court.

13. That when some prior patent is cited against your application, you must execute some sort of paper admitting its validity. On the contrary, you can avoid the citation by showing either that your invention does not come under it, or that your invention, although subsidiary to the other, yet constitutes an improvement upon it.

14. That the mention of some prior patent in a printed specification shows that some such paper, as mentioned above, has been filed. On the contrary, there is no such thing. This mention is usually either for the purpose of shortening your description by referring to some well-known prior device, or for the purpose of obtaining the benefit of the earlier filing date of some other application of your own.

15. That patent office tactics are no concern of the inventor. On the contrary, many a patent proceeding has been spoiled through the failure of the inventor to keep intelligently in touch with the different moves which his attorney was making.

16. That there is something wonderful in a lawyer's being able to guarantee the securing of a patent. On the contrary, I myself will guarantee to get any one a patent on almost anything, old or new; but I will not guarantee that this patent will be worth a nickel.

17. That it is wise to hire a patent lawyer on a contingent-fee basis. On the contrary, a patent application is unlike a damage suit, for in the case of a patent it is impossible to measure the value of the results. A contingent-fee patent case is likely to be carelessly handled.

18. That a clear abstract of title means a clear title. On the contrary, there may be outstanding a valid license, which has not been recorded in the Patent Office.

19. That, at least, the ownership of a valid patent clears you of all prior patents which were not cited against your application. On the contrary, your patent may infringe some patent of which you have never heard, and yet may be clear of many which were cited against it.

20. That the patent examiner exhausts the prior art. On the contrary, patent examiners are overworked and underpaid, and often issue a patent which is absolutely void because of some overlooked prior patent which is directly in point.

In general, remember that nearly every bit of current belief about patent law is decidedly *not* so. The more that anyone says, "Oh, everybody knows that!", the wiser it will be for you to run to some authoritative book and *look it up!*



# The Set the Boy and His Dad Built

By ARTHUR N. KING

(Dad)

SAY, Dad, if you will help me get a radio set, I'll stop wanting a bicycle." Dad said, "All right," and so the work was begun.

The boy had made several attempts at winding coils and finally had made a very good loose coupler from material obtained at a five-and-ten-cent store. A crystal detector came from the same source. The boy and his younger brother found some long poles in the woods and used them to erect an antenna about sixteen feet high and forty feet long. A good set of phones completed the outfit and after some strained listening the boys heard a bit of code, but it was like a foreign language to them.

The next act was to purchase a vacuum-tube socket, a rheostat, grid condenser, variable air condenser, and a variometer. Dad made up a little unit containing the control for the detector filament; etc. Mother contributed a small table to put the apparatus on. A UV-200 detector tube and five flashlight batteries were then bought, the latter to be used as the 22½-volt B battery.

Dad didn't want an outdoor antenna, so it

was up to him to provide one in the attic. One night the two boys and Dad shed most of their clothes, donned overalls and climbed up through a trap door into the attic which was barely four feet high in the centre. A very few boards, nailed here and there over the joists which held the ceiling below, made a precarious



footing, or rather backing, for they had to move around on their backs most of the time. One boy held the lantern, the other held the wire, and Dad nailed up the insulators and fastened the wire; while down below the family dog, Jakey, cocked one ear aloft and looked as if he wanted to help too. Always afraid of putting their feet through the plaster, the trio wriggled and squirmed, pounded, puffed, and groaned for nearly three hours. When they crawled down, the attic was well dusted and they were fit only to get into the bath tub.

The next night Dad finished tacking the lead-in wire through a closet and along the baseboard of the boys' room to where the radio table was.

A kind neighbor came in with a spare A battery which he said they could use until they were able to get one of their own. This Good Samaritan brought a newspaper with him, which showed a diagram of the hook-up to be used. Dad was mighty glad that this was *the* hook-up, for he has always felt that there were as many hook-ups as there are radio fans, maybe more, for some fans seem to be constantly dopping out new ones.

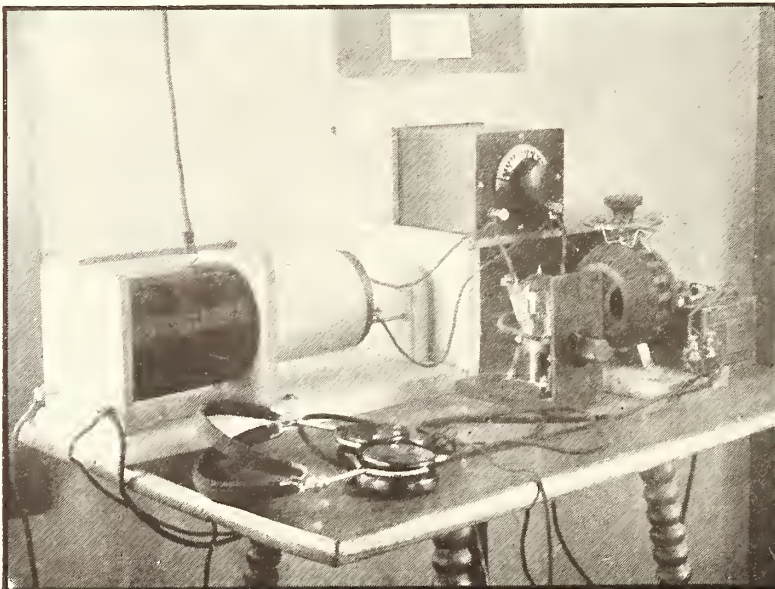

THE SET



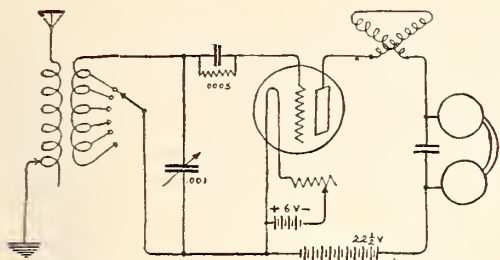

THE GOOD SAMARITAN'S HOOK-UP

When the stuff had been fastened to the table top, the Good Samaritan studied his treasured hook-up and fastened bits of wire here and there on the apparatus and finally connected it to the batteries. The ground wire was attached to a radiator. Then, oh critical moment, he put on his headset and began to move different things while he listened for something. The bulb lighted but it wouldn't talk. What could the matter be? Dad and the G. S. compared the hook-up with the different wire connections and found a disagreement between them. Changing the wires he listened again. Suspense . . . WAAJ! Hurrah! Twenty watts, eleven miles away and our set was getting it. Then he tuned in WNAC, Boston, and all hands called it a night and went to bed.

Two days later, Boy, Dad, and Company



STATES HEARD FROM WALTHAM, MASS.

picked up "the Voice of the Air" at WGI, Medford Hillside, Mass., and after more than two weeks heard WJZ and WOR in Newark, N. J. Then a few days later came KDKA, "the Pioneer Broadcasting Station," over in Pittsburgh, and oh boy!—what a queer feeling they had when they thought of its being so far away! Did you ever have that feeling?

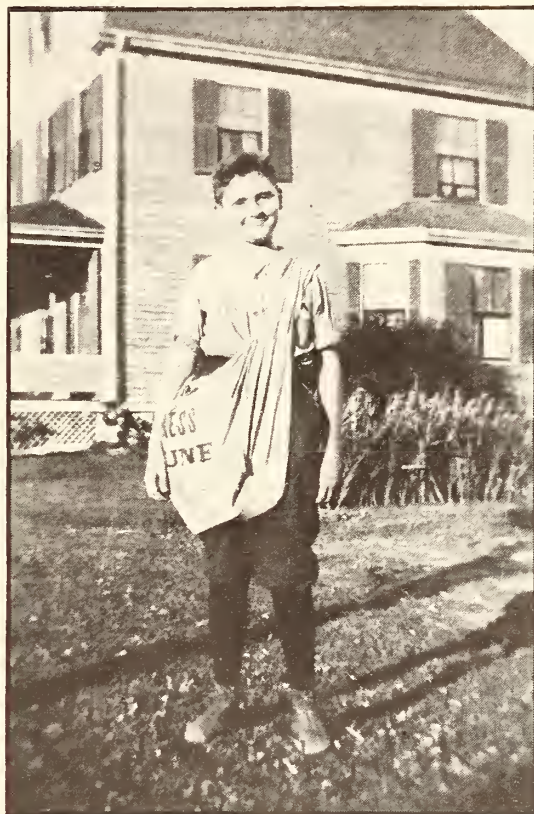

THE BOY

Dad was becoming handier at the tuning and he added WFAU and then WGY, "the Generous Electric Company" in Schenectady. Then, from the G. E. factory, he skipped over to school in Troy, WHAZ, and then back nearer home to WCN, Clark University.

Hearing about the electric light socket attachments that could be used for an antenna, the boy bought one and it has been in use ever since.

Don't forget that this was the boy's set, but Dad appointed himself chief operator and was on the job almost every evening. The younger lad contributed another pair of phones, so that by dividing up the ear pieces, four people could listen at one time, as shown in the etching of the family quartet.

The family next became acquainted with the great public service company at WEA, New York City. Then up the Hudson a bit was WRW in that town which reminds one



THE F. Q.

of Washington Irving. Skipping east again they stopped to listen to WBZ, Springfield, and then a big jump south landed them with the navy at NOF in the District of Columbia. A step backward and they heard that noble organ at WOO in the store of one of the great merchants, in Philadelphia. Then one Sunday evening, faintly came the words, "WDAP, Chicago!" If getting KDKA had made Dad feel queer, think of his feelings now. He almost slipped off his chair, he was so excited. With his hands off the dials, there was silence, with his hands touching the dials came music from WDAP.

"Hello boy, wake up!"

"What's matter," muttered the boy.

"Got Chicago! Put the phones on and listen!" At this a sleepy boy rolled out of bed, slipped on the phones and heard Chicago while Dad held the dials. What bliss; and the boy had wanted to change the hook-up because for a long time we couldn't hear WJZ!

Skipping back to rugged New England they heard the voice of the Green Mountain State from WLAK; and then the Courier-Journal, WHAS, called then to Kentucky, the old hunting ground of Daniel Boone. What boy doesn't like to read about him? While they are thinking about hunting and Indians, Pontiac comes to their minds as they hear WWJ talking from Detroit. Back down in Philadelphia, another merchant announced WIP, further south they listened to WBT, in Charlotte, North Carolina. Returning a bit they heard "Hello Uncle Johnny, Hello Everybody" at Station WQAA. WRP in Camden, N. J.

reminded them of the school-days history of the Revolutionary War, and then in a few minutes they were on the banks of the Father of the Waters listening to the call of WOC, "Where the West Begins, and the Land

Where the Tall Corn Grows," and the name of a school having a queer name which they didn't understand.

They paused to breathe again, for they had broken their distance record. The next night from KYW in Chicago came the strains of that splendid grand march from the opera "Aida," played in the Chicago Opera House. The following evening they stopped in the midst of the machine tool industry and heard WLW, Cincinnati, Ohio. Skipping up to Buffalo

they heard WGR. WGM, "The Voice of the South" calling from Atlanta, Georgia, reminded them of Sherman's March to the Sea. Moving the condenser one degree carried them to a foreign shore, where a voice said, "Habana, Cuba." Shades of the buccaneers! Dad and his better half nudged each other and held fast.



An announcement in English and one in Spanish, then a fine piece of orchestral music followed by the call PWX, assured them that it was indeed a foreign land. Fifteen hundred miles away, and they could hear the talking and music.

Doesn't the wonder of it almost take your breath? Oh yes, they have a clock down at PWX and you can hear it tick.

The next evening the boy made his farthest West by hearing WHB, Kansas City, Missouri, in the heart of America.

Returning east once more the boy and his Dad heard WHN on Long Island. Next they were out by the Mississippi listening to KSD in St. Louis and were reminded of Churchill's story "The Crisis." Then the "Wave from Lake Erie," WJAX, broke on their ears and they remembered about the battle of Lake Erie which took place at Put-in-Bay, fifty or sixty miles west of Cleveland. Ever been to Put-in-Bay? There are some mighty interesting caves there and one of them is said to have been a hiding place of Perry's.



So they go, skipping here and there, making the acquaintance of places far from home, studying maps and listening to people whom they had never expected to hear but are usually glad to have heard. They hear the tum, tum, tum of the fox-trot, the melody of Grand Opera, a talk about the Everglades, politics, books, medicine, or clothing. All Dad knows about a boxing match came from a bout at Madison Square Garden. One night there was the story of the Creation told in an ancient Indian language so old that only one man in the world could now speak it. Subjects innumerable, and a whole education for those who have the time to listen.



Broadcast reception is very erratic. It is not always the powerful stations which have been heard through the greatest distance. One night they picked up WHAK, a twenty-watt station 570 miles away in West Virginia and the next night Dad listened to WBL, a fifty-watt station, 1545 miles away in Anthony, Kansas.

Do you who live in the Central States ever stop to think what a fortunate location you enjoy? You can just tune in to the different stations in every direction around you, while radio fans on the Eastern edge of the country can listen-in on only half of the horizon, for not many people have stations that can get Europe.

One night, the boy started for bed and some time later, Dad, not having heard the usual cheery "Good-night," went up to investigate. Lo and behold, the boy had a regular loud-speaker working. He was stretched out on two chairs, with his feet on the radiator, phones on his ears, sound asleep and snoring like a saw-mill.

Ma wanted to understand code and now each evening at suppertime, while preparing the evening meal, she keeps one eye

on the clock so as not to be tardy at the receiver when Uncle Jack starts sending slow code from WGI. Now, when Dad and Ma are listening to a concert and code comes slamming in to the exclusion of all else, Ma doesn't mind at all, but listens to the dah-dit-dah and smiles while Dad sits by in a spirit of resignation.

Did you ever have a radio ghost in your house? One night Dad was roused from sound slumber by Ma, who said, "There's a queer noise downstairs." Dad didn't hear anything for a few moments, then all at once there came the sound of a telegraph ticker; a few taps and then silence, a few more taps and silence. The boy had a practice set, but he was sound asleep, so Dad made a trip downstairs to investigate. On a table was a dry-cell lying near a telegraph ticker. Suddenly, while Dad stood still, looking and listening, the instrument began clicking. Not a hand near it. A few taps and then silence. Dad thought it about time for the ghost to go to bed, so he carefully looked the outfit over and found that while there was one wire connected between the battery and the ticker, the second wire was disconnected at one end but lying in such a way that a slight vibration of the building would cause the wire to make a contact and the ticker would momentarily operate. Removing the wires laid

the ghost, and Ma and Dad slumbered quietly the rest of the night.

Dad usually joins the boy at the radio set for a while every night before retiring. No matter how sleepy or tired he is, a few minutes' listening-in brightens him right up, but oh how aggravating are those faint indistinct announcements that can't be brought in! Just aggravating enough to make Dad want some radio-frequency amplification. You will see by the photo of the set that the controls are in such positions as to cause a great deal of trouble from body capacity. This was avoided to a certain extent by slipping a brass tube about two and one-half inches long over the detector bulb and connecting the brass to the ground wire. This arrangement made the set more stable, but several stations previously heard are now dumb, so Dad removed the brass tube in order to have another try at those stations. From the operation of the boy's receiver, Dad is firmly convinced that the best way to avoid trouble from body capacity is to use long shafts on the controls, preferably of nonmetallic material. A friend of Dad's extended the shaft of a grid variometer and placed on it a talking machine disc record for a dial. This arrangement gave excellent results as it avoided the body capacity effects, and the large dial gave a very sensitive control of the instrument, permitting the tuning-in of stations whose broadcast was formerly nothing but noises.



THE BEST WAY TO AVOID BODY CAPACITY

Of the calls heard, the worst mix-up was when two stations were alternating their programs and announcements: WHN, Ridge-wood, Long Island, and WEAG, Edgewood, Rhode Island. The two kinds of wood and islands certainly had everyone puzzled.

# R. F. Amplification Without Distortion or Reradiation

By EDWARD LINDLEY BOWLES

Instructor in Electrical Communication, Massachusetts Institute of Technology

Many beginners have been intrigued by the claims made for various involved circuits. For the novice, radio frequency is complicated, and its use does not always result in greater range with a home-made outfit.

You will do well to attempt R. F. amplification only after you have mastered a regenerative receiver and A. F. amplifier. This is especially true since the change in the broadcasting wavelengths has been in effect, because few transformers will cover satisfactorily a range from 220 to 550 meters.

We do not wish to discourage the use of radio frequency, but we do wish to discourage indiscriminate buying which results in disappointment to the buyer and ultimate reduction of sales for the dealer. —THE EDITOR.

**T**O-DAY the question of radio-frequency amplification is uppermost in the minds of both the amateur and the broadcast listener. Since the new allocation of wavelengths, the broadcast receiving set is not confined in its operation to wavelengths in the neighborhood of 360 and 400 meters, but it must range from as high as 550 meters to as low as 220 meters.

Volumes have been written on radio-frequency amplification, in which proponents of particular methods have been eager to convince readers of the merits of their choice circuits. Yet, many of those who have attempted to construct their own radio-frequency amplifiers for short wavelength work have been disappointed in the results. This is due to an in-

adequate knowledge of the functioning of the units employed, and the natural tendency to judge as "best" the circuits bearing high-sounding names and blessed with good press agents.

Many so-called radio-frequency amplifying transformers, or amplifying devices, which have been advertised for the shorter wavelengths, have proved to be poor. In fact, the writer has found that in some cases so-called short wavelength radio-frequency amplifying devices have done more harm than good. It seems only fitting that since radio broadcasting has reached a point where many wavelengths must be used in order to relieve congestion, and since these wavelengths must be "short," the broadcast public should have a general idea, at least, as to why there is likely to be difficulty in applying

only general ideas of radio-frequency amplification to circuits which they have already constructed or which they propose to construct, in order that these difficulties may be avoided.

Technical analysis has shown that R. F. amplification is more effective than A. F. in bringing in distant signals. Of course, if a signal is too weak, no matter how good the receiving set may be, the signal will not come in. In other words, there must be a slight disturbance, at least, in the neighborhood of the antenna or loop, in order that the re-

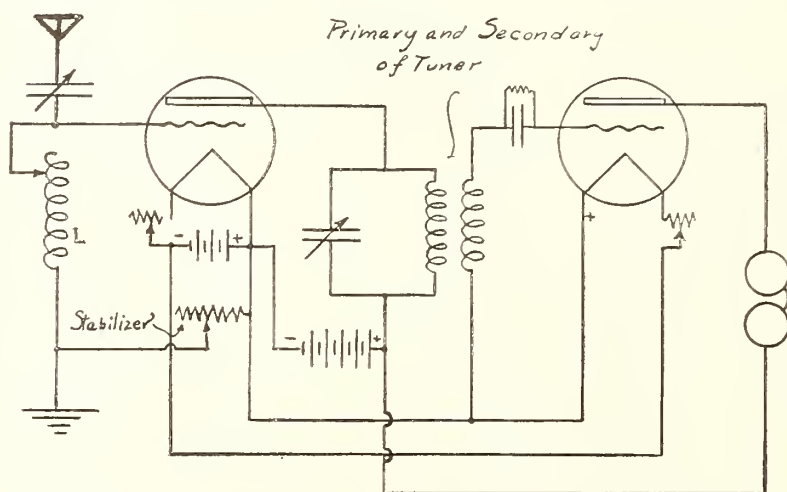

FIG. 1

R. F. amplifier showing a tuned primary transformer



ceiving apparatus may be affected. The antenna is capable of grasping more of the energy sent out in the form of waves than is the loop. As a consequence, much more amplification is necessary where a loop is used. In either case, where a single tube is used, and where signals are not coming in strong, or where distant signals can not be heard, one is confronted with the problem of introducing some sort of amplification. One can use audio-frequency—a common practice—or radio-frequency. Audio-frequency has, of course, become very popular, and many receiving sets are now equipped with a stage or two of such amplification. Two stages of audio-frequency amplification, a regenerative tuner, and a detector tube, make the most popular combination. If a loud speaker is used, the amount of energy delivered by the two stages of amplification is not always sufficient to operate, especially in large, open places, so that in some cases an additional amplifier, usually of three tubes, is used to furnish sufficient energy to operate the loud speaker diaphragm.

It has been shown by actual analysis that the detector tube is comparatively more sensitive when it is affected by a strong signal than when it is affected by a weak one. In fact, the effect which signals can produce on a detector is probably roughly proportional to their square. That is, if the intensity of the impressed signal is doubled, its effect will be quadrupled. It is evident, then, that any amplification of the incoming signal which can be made before it reaches the detector tube will have an effect far greater than the same amount of amplification of the signal after it has affected the detector tube. Roughly, a radio-frequency (voltage) amplification of 10 has the same effect as an audio-frequency (voltage) amplification of 100. It is for this reason that so much effort has been made to devise apparatus which would properly amplify signals at radio frequency.

The design of radio-frequency amplifying circuits for the longer wavelengths is a comparatively simple matter. The long wavelengths correspond to the lower frequencies, and it is much easier to build circuits to behave properly at low frequencies than it is to build them to behave properly at high frequencies.

Various radio-frequency amplifiers were discussed in two articles by Mr. Arthur H. Lynch in the March and April issues of RADIO BROADCAST. Ordinarily, tremendous amplification is

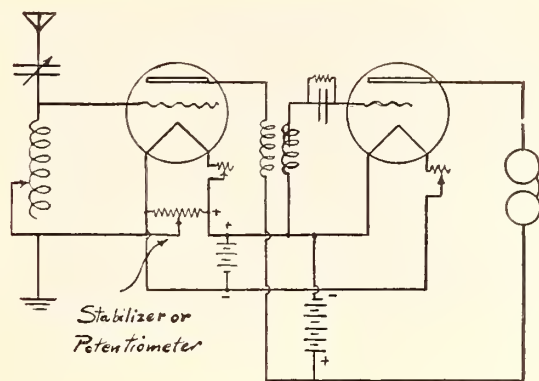

FIG. 2

An air-cored transformer-coupled amplifier with a potentiometer to control the R. F. tube

obtained by regeneration; and even greater amplification can be obtained by super-regeneration; but, at the same time, regeneration introduces distortion, and produces reradiation. Improperly adjusted regenerative sets may make a particular locality untenable for others who are attempting to receive, for the latter, in making their own adjustments, will be greeted with a series of variable howls and squeals which are anything but enjoyable. Regeneration can be used in conjunction with radio-frequency amplification, however, so as to prevent reradiation.

The greatest difficulty in radio-frequency amplification is to obtain this amplification without regeneration. Many of the coupled radio-frequency amplifiers for short wavelengths operate as regenerative circuits, so that after all, the amplification in this case is determined by regeneration and not by what we would ordinarily term direct tube amplification—due to the amplification factor of the tube itself. An example of a tuned radio-frequency amplifier, as produced by a commercial company at the present time, is shown in Fig. 1. This amplifier is constructed with a set of four output coils so that it operates at from 150 to 3,000 meters. The radio-frequency amplifier is coupled to the detector tube. The grid bias voltage is obtained by means of the stabilizer shown in the figure. This stabilizer makes it possible to prevent the amplifier from oscillating. When the arrow is at the extreme right, the grid of the tube is most positive, and when it is at the extreme left, the grid is most negative. As the arrow moves toward the left, the circuit is more and more likely to oscillate. A radio-frequency amplifier should operate with-

out regeneration and without oscillating. Those who have operated a regenerative receiver know that as the tickler is moved up to a certain point no sound is heard, but suddenly a definite point is reached where a click is heard in the telephones. This click is due to the fact

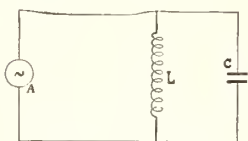

FIG. 3  
A schematic circuit showing how a condenser and an inductance in parallel may divide the current

that the tube has begun to oscillate at a radio-frequency. When the tube oscillates, the current furnished to the tube by the B battery changes and it is the change of this current through the receivers that produces the click. When the tickler is moved still further, another click will be heard. This second click indicates that the oscillations have ceased. In tuning-in a station, regeneration is obtained (if the setting of the tuner is correct for the particular station) just before the first click occurs. If a radio-frequency amplifier is oscillating at a radio frequency, this fact can be detected by touching the finger to the grid of the tube. If oscillations are present, they will be stopped by this act so that a distinct click will be heard in the telephones. This is not the proper state of a radio-frequency amplifier.

Fig. 2 shows a simple type of radio-frequency amplifier involving an air core coupling transformer. The operation of such a circuit is very difficult at short wavelengths because the tubes are almost bound to oscillate unless the potentiometers shown are so adjusted that the grids of the tubes are positive. When the grids are positive, the possibility of oscillation, and therefore of regeneration, is reduced, but it will usually be found that under these conditions the ordinary radio-frequency amplifier is not of much use. In other words, if the grids are made positive and then are slowly made negative, in the act of tuning, it will be found that the operation of the circuit will depend upon a critical adjustment of the potentiometers. This means that the circuit is operating on the border of oscillation; that is, it is acting as a regenerative circuit. This can be definitely determined by having the circuit in operation under such conditions and by sliding the potentiometer dial in such a position that the grid is as negative as possible (that is, by sliding the potentiometer to the extreme left in the

figure). Under these conditions, if the amplifier is oscillating, a distinct click will be heard on touching the grid connections of either tube.

The action of radio-frequency circuits may be understood more clearly by considering some of the units which make them up. For instance, a coil of wire in an electric circuit offers no more opposition to the flow of direct current (that is, current flowing in one direction only and interchanging in value) when the wire is in this form than it does when the wire is unwound. For currents which alternate in direction, the situation is different. The higher the frequency, the more opposition the coil offers to the flow of current.

Further, an electric condenser is made up of two adjacent conducting surfaces separated by an insulating material. It does not allow any direct current to pass through it, yet, if an alternating voltage is impressed on a circuit containing a condenser, the current which flows depends upon the frequency. The higher the frequency of the alternations of the impressed electric force or voltage, the greater the current. Short wavelengths correspond to high frequencies. For example, a wavelength of 300 meters represents a frequency of one million cycles a second. A wavelength of 100 meters represents a frequency of three million

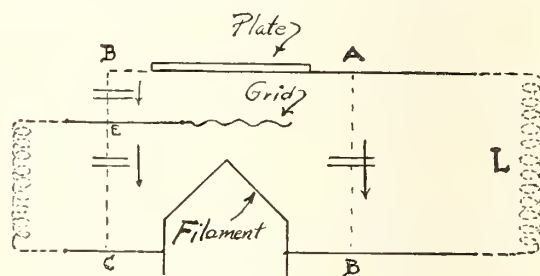

FIG. 4  
A schematic diagram showing the little fixed condensers which are present in every vacuum tube

cycles a second. Keeping these facts in mind, the result can be illustrated by means of the circuit shown in Fig. 3, where there is an alternating current generator capable of producing an electric force or voltage of any desired frequency. If the frequency is very low, all the current will flow through the coil L, for the lower the frequency the less will be the opposition which the coil offers to the flow of current through it. At high frequencies, the tendency of the current will be to flow through the condenser C, for the higher the frequency the



lower will be the opposition which the condenser offers to the flow of current through it. It is possible, then, to have a frequency so high that much of the current will be passed by the condenser C. When the frequency is such that the opposition offered by the condenser is practically the same as the opposition offered by the inductance, then the circuit is said to be in resonance. Such is the case, for example, when the parallel circuit of Fig. 1, made up of the condenser and inductance, is properly tuned to a particular wave.

A very small capacity may have a very harmful effect at high frequencies. In the case of radio-frequency amplification, the little condensers in the vacuum tubes themselves cause much mischief. Small condensers are formed by the grid and filament, and by the plate and grid, so that if we were to represent these little condensers on the outside of a vacuum tube, we would have a picture much like that shown in Fig. 4. These little condensers are capable of causing oscillations at high frequencies, for if a pressure exists between the points AB, it will not only send a current through the little condensers represented by the plate and filament, but it will also send a current from B to C through the little condensers represented by the plate and grid, and by the grid and filament, respectively. The current flowing through the condenser between E and C causes the proper kind of voltage to be impressed on the grid of a tube to produce an oscillating current in the plate circuit, if the plate circuit contains a small amount of inductance, as shown. Usually the grid circuit also is tuned by an inductance, as shown by



FIG. 5

A recently developed set of the Clapp-Eastham Company, having one stage of R. F., detector, and two stages of A. F. amplification

the dotted line. This aggravates the tendency for the tube to oscillate. Therefore one may construct a radio-frequency amplifier with apparently no condensers, and yet the amplifier may oscillate and give no results whatever.

Tuning the transformers of a radio-frequency amplifier has the effect of building up parallel circuits of capacitance and inductance eager to oscillate, but in the receiver illustrated in Fig. 5, this tendency is curbed as shown in Fig. 6.

The tuning element consists of a series antenna condenser C<sub>1</sub> in series with a variometer V. The first tube is used as a radio-frequency amplifier, and it is coupled to the detector tube by means of a tuned primary radio-frequency transformer which is prevented from oscillating by means of the control condenser C<sub>2</sub>. This little condenser is a variable of about .0002 mfd. capacity. The primary of the radio-frequency transformer is tuned by means of

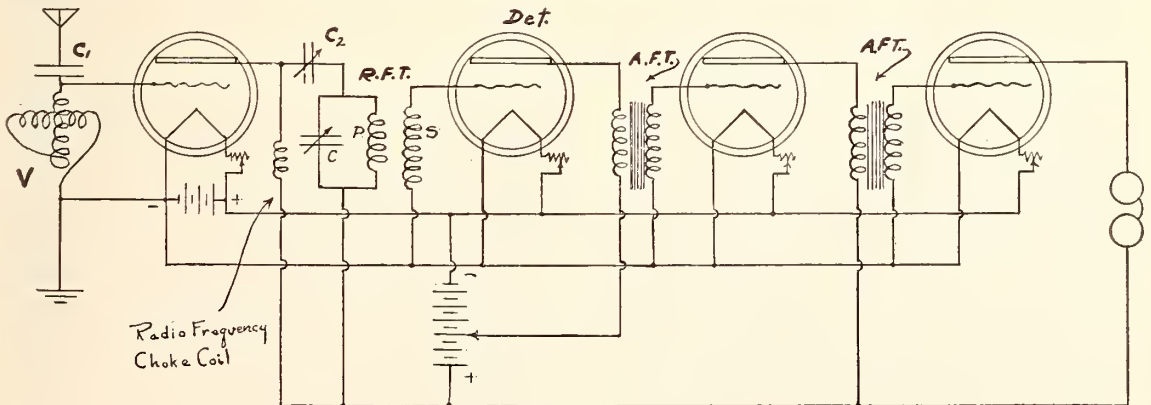

FIG. 6

Wiring diagram of the set shown in Fig. 5. The oscillation condenser is shown as C<sub>2</sub>. Note that the B battery feeds the plate of the R. F. tube through a choke-coil

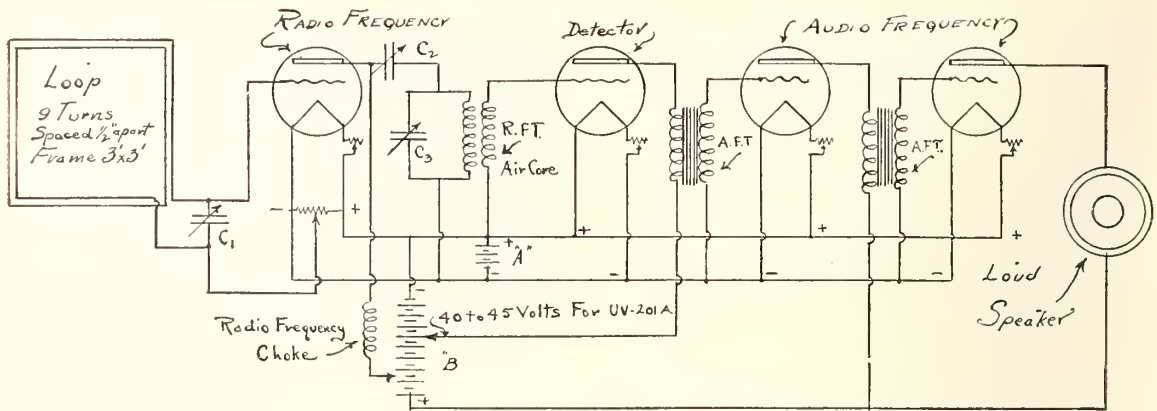

FIG. 7

A suggested hook-up. The oscillation control condenser is shown as C2. Note that there is no grid condenser or grid leak

the condenser C3, which has a maximum capacity of .001 mfd. The secondary of the radio-frequency transformer is not tuned in any way, but it is connected directly to the grid of the detector tube, as shown. The control condenser in the plate circuit makes it necessary to furnish the B battery voltage to the plate through the radio-frequency choke shown. This is an iron-cored coil. No grid bias is used in this set and there is no stabilizing device such as a potentiometer. It is interesting to observe that the detector tube contains no grid leak or grid condenser. The designing engineer for this company has found that the insertion of the grid leak and grid condenser in the set actually hinders its operation.

The detector tube works with two stages of audio-frequency amplification, as shown. These are of the usual form. The dial marked "Osc. Control" (Fig. 5) operates the condenser C2 (Fig. 6). The dial marked "antenna inductance" operates the variometer V, and the dial marked "radio-frequency control" operates the condenser C3. These dials are unique in that they operate at all times with a micrometer adjustment; that is, the knob makes several revolutions in order to advance the dial through its full scale. The condensers C2 and C3 are so arranged that the shaft supporting the moveable plates, and running to the knob, is always farthest from the plate side of the condenser; that is, it is always at the potential nearest that of the filament. In this way, body capacity effects are nearly eliminated.

A variation of this circuit is shown in Fig. 7. In this circuit a loop is used in conjunction with a small tuning condenser C1. The control

condenser is shown as C2, and the transformer tuning condenser as C3. The radio-frequency transformer may be made up of cardboard tubes. Bakelite apparently does not work as well under ordinary conditions. The two windings may be placed one inside the other, as shown in Fig. 8. The inner winding may be used as the primary and the outer winding as the secondary. Both coils should be wound in the same direction. They can be made up with ordinary cotton covered or enameled wire of from Nos. 22 to 26. The primary should have comparatively few turns compared to the

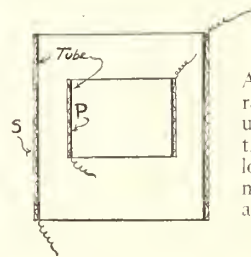

FIG. 8

A cross-section showing the arrangement of the coils that make up the primary and secondary of the R. F. transformer. The two lower leads should go to the filament and B battery if both coils are wound in the same direction

secondary. The exact number can be determined only by practice. Roughly, from 30 to 40 turns on the primary and from 75 to 100 turns on the secondary will probably give good results if the ratio of the diameter of the primary winding to that of the secondary is about 0.6. The radio-frequency choke may consist of an old primary of an audio-frequency amplifying transformer or any iron-cored coil of only a few layers in which the wire is not too fine.

This set is subject to almost perfect control by means of the series plate condenser C2, and with it, radio-frequency at short wavelengths is very satisfactorily accomplished.



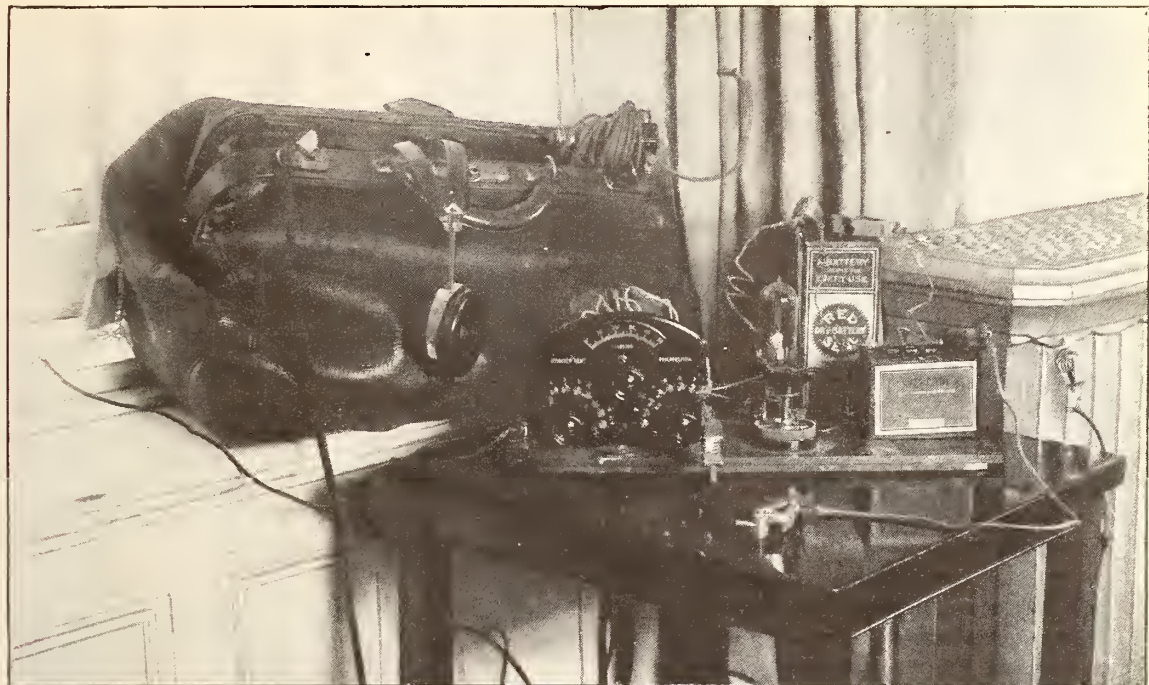

© Clinedinst

#### IT DOESN'T TAKE LONG TO GET IT HOOKED UP

At the left is the antenna wire, flung out of the window, and at the extreme right, the ground connection on the radiator. The plug and roll of wire in the jaws of the traveling bag are an alternative aerial appliance

## A Portable Set for Lonely Hotel Hours

By J. T. N.

SOME cynical person has said that love of home is chiefly expressed and upheld by the homeless. However that may be, I am one of those to whom days and nights at home are a luxury, and days and nights in hotels the all too common experience. To relieve the monotony there have been always, of course, various expedients, theatres, movies, books. None, however, as good as modern radio. At least I find it so. I am often too tired for theatre or movies, even if there is an attractive offering. Also my mind is generally too full of the day's work to favor the concentration necessary for profitable reading. Radio makes fewer demands. No matter how tired or preoccupied, you can listen. Sweet voices sing for you, bands play, violins, horns, orchestras, organs. Besides there are frequently broadcasts of banquets and public meetings. Even lectures and speeches do not tax your tired energies

when you know they can be turned off without disturbance (or discourtesy) the moment they fail to hold the attention.

The advantages of radio under such circumstances are obvious enough and do not require elaboration. My purpose here is to tell how I manage my hotel radio.

My method is simple. After years of experience in regulating luggage—the problem is to carry all one needs but not a scrap more—I have settled down to a suit case for clothing, a small bag for toilet articles, pajamas, books, etc., and a brief case for documents. The brief case frequently travels in the suit case, leaving only two articles of hand luggage. To add radio to the outfit was more or less disconcerting to one of settled habits. I considered having a small case made the size of a set, with the panel just inside the lid. But at best this involved a third thing to carry and a fourth when the brief case could not go inside. So I

rejected the idea of radio in a separate case. I then tried packing the essentials of a hook-up in the suit case, but they would not stay put, and the result was a mess, involving poor radio, because of loosened joints and fittings. Finally I decided to get a larger hand bag to substitute for the small one carrying toilet articles. I selected one with a fairly wide bottom and ample jaws. On a board or base a little smaller than the bottom of the bag I fastened a vario-coupler, a WD-11 tube socket, a small rheostat, a combination grid-condenser and *variable* grid leak, and four small binding posts. These I screwed down securely wired with the shortest possible leads. All connections were well soldered. To the most convenient negative A battery lead, I soldered short, flexible insulated wire terminating in a strong battery clip and added the same equipment for the positive A battery lead and the positive B battery lead. (In my hook-up, as will be seen,<sup>1</sup> the negative B battery lead connects with the negative of the A battery, and consequently this is not a part of the fixtures on the board.) I also soldered a short, flexible wire terminating in a battery clip to the plate lead. This is for connecting the phones. The outfit thus assembled goes to the bottom of the traveling bag. It is not much of a nuisance there as it is all firmly put together. The vario-coupler is a commercial unit already equipped with dial, switch lever and points, fixed on a little panel of its own. Into the bag, in convenient corners, I also tuck a roll of about fifty feet of No. 18 stranded flexible insulated wire, a small 22½-volt B battery, another roll of about ten feet of the same wire with battery clips on both ends, a short wire similarly provided, a pair of head phones, and (in case it is best to use it for an aerial connection) a radio plug for an electric light socket, with about fifteen feet of flexible insulated wire attached, terminating in a battery clip. I carry also two WD-11 tubes, one for use and one reserve against a possible blow out. I have as yet no satisfactory place to carry the tubes and they go in the suit case cushioned by the wearing apparel. But this is a poor makeshift. Some sort of a small box, padded and partitioned,



would be the thing, but I have never happened on one so far.

There is nothing peculiar about the hook-up I use and doubtless it could be improved somewhat so as to give even better results. However, I would reject any modification which called for more parts, as I now carry quite enough miscellany in that bag. (My wife occasionally inspects it with expressions of horror.)

One who lives much in hotels learns to adapt himself to circumstances. To have radio in a hotel it is necessary to call upon this acquired aptitude. If I arrive in daylight (and as well as I can anyway) I inspect the environment before registering. To the room clerk I probably appear rather a fussy old gentleman, possibly slipping into a paranoic state with fixed ideas, obsessions, violent likes and dislikes. Or he may be "on." These hotel

clerks know a lot they say nothing about.

I show marked preference for rooms at the top. I like them at the front, or at the rear, or at the side, *as the case may be*, and in each case I am very definite about it. (It depends on where I saw the telephone and telegraph wires, the trolley lines and the near by or connecting buildings). I am apt to inquire casually about the construction of the building. Old hotels are best. They may burn you up, but in the meantime the radio will be better. No metal construction, of course, is the reason. Also I have a weather eye out for the hotel detective. I do not intend to violate any rules, but if he subsequently thinks my wire (if I use it) is intended to facilitate an escape without paying my bill, I want to explain before he insults me.

Having done as well as I can in the location of my room, I inspect its interior. A glance takes in windows, ledges, available ground. Radiators are usually all right for that; maybe bathroom connections are better, but I seldom use them as they are inconveniently placed. Recently in an overcrowded hotel where I had to grab anything I could get, the room had no bath and no radiator. It was in the South. I used the electric light wires there for the aerial and was puzzled what to do for ground. Finally I fastened the ground wire to the bed springs. It worked beautifully. I'd heard of bed springs for aeriels but not for ground. (It

<sup>1</sup>J. T. N.'s hook-up is practically the same as the "Parker" circuit. This is shown in Fig. 1, page 230, of this issue.



would be a counter-poise doubtless.) But I cannot claim a discovery, for the bed spring connection fell off and the reception went on without any change whatever. This was one of the old hotels, God bless 'em, no steel construction nor reinforced concrete.

Where it will work, and usually it will, I prefer to drop my fifty-foot wire over the window sill. I select a small table, move it over by the window, take out my outfit, throw out my wire, and clip my ground wire to the radiator. One telephone lead I attach to the plate circuit by letting the clip bite it, and the other telephone lead I insert directly in the proper tap of the B battery. My short double clipped wire connects B minus with A minus. I forgot to tell about the filament battery. I exclude it from my outfit because dry-cell batteries are purchasable at all hours and at low cost in any city.

If the outside wire will not work or conditions will not permit its use, I try the electric light connection. I have never had any real trouble. Most cities have local broadcast stations or are near some other city that has. Sometimes those near enough for my single tube and more or less haphazard equipment operate only semi-occasionally or on restricted

schedules which do not match my hours of freedom, but I seldom fail to find real entertainment ready at hand. Even if broadcasts are lacking there are near by amateurs handling "traffic." One lulls a child to sleep with monotony and repetition. The c-q-ing of the amateurs has a similar effect, and I am apt to grow drowsy. Well, that was what I wanted, wasn't it?



© Chinedinst

A WELCOME RELAXATION, AFTER A DAY OF WORK AND TRAVEL  
The portable apparatus in action at the Shoreham Hotel in Washington

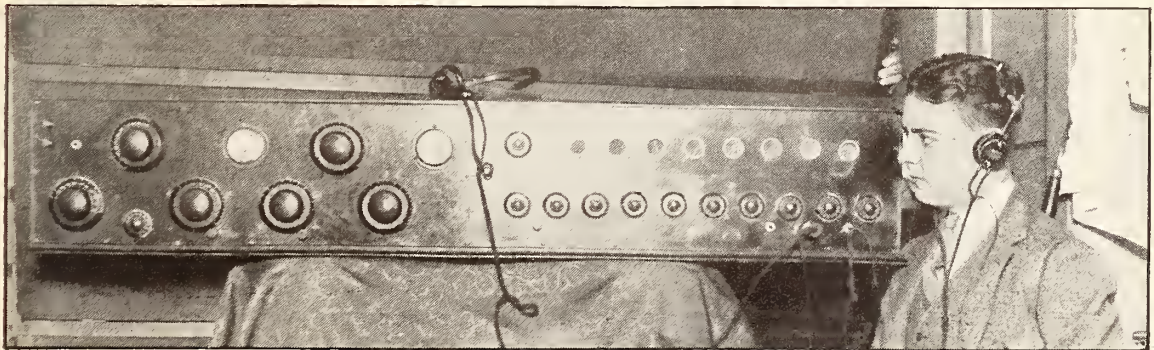

THE 10-TUBE SUPER-HETERODYNE SET WITH WHICH R. R. MAYO, WHO BUILT IT, HEARS  
EUROPE REGULARLY



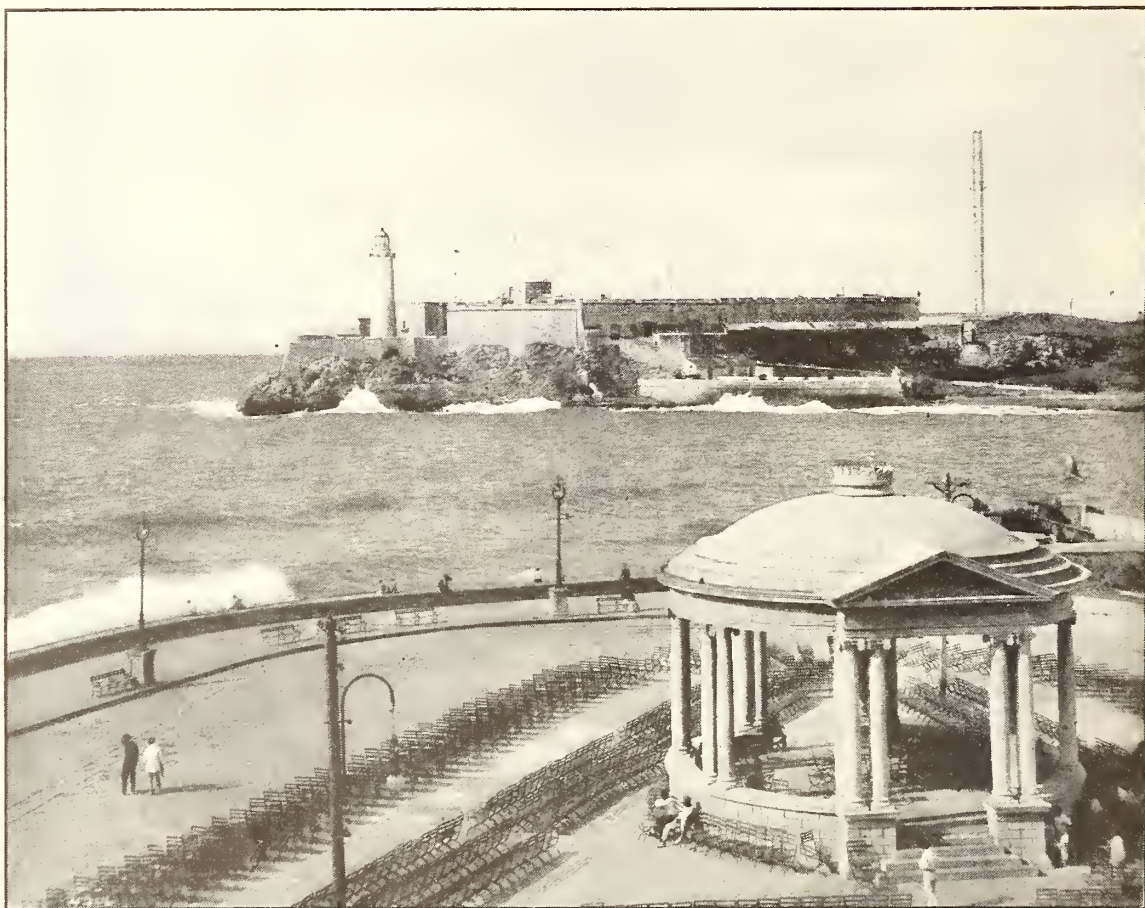

AT THE FOOT OF THE PRADO, HAVANA

Where Cuban beauties and beggars share the moonlight and the music, while the light on famous old Morro Castle winks first at them and then at the men who go down to the sea in ships

## A Millionaire's Cruise on an Operator's Pay

By A. HENRY

Yachting on \$40 a month is possible only for radio men (and not always for them!) In this article—the fifth on the subject of “Operating as a Career”—Mr. Henry shows us further lights and shadows of one of the most fascinating jobs in the world.—THE EDITOR.

**F**OLLOWING my dismissal for having missed a vessel sailing for Nova Scotia, you may imagine my surprise when I was told by the Superintendent that my case had been reconsidered and that he was pleased to offer me a fine assignment. After dilating upon the wonderful cruise the yacht was to take, it was no

longer necessary for him to “sell” the job to me. As advertising men say, I was completely “sold.” Before letting him know this, however, I went through the business of showing indifference and mentioning an assignment promised me by a competing company in the approved manner. Yes, I secured the raise.

The reason for my being selected was that a



radio outfit had to be installed on the particular yacht which I was to meet at Key West, and I had done a similar job on the *Wakiva*, down in Tampico. The equipment had been on its way a day or two and they were anxious to have me follow as soon as possible. A steamer was leaving New York in two days for Key West and I would have to take it and stay at a hotel there until the yacht came in. Well, you can imagine how my adventuresome nature responded to that! One does not care to abandon the winds and snows of New York in February for the sunshine and flowers of the tropics, but—I permitted myself to be persuaded.

Oh, those days when one is foot-loose and fancy-free, gloriously young and satisfied to be off in a balmy, spring climate, bound for nothing more definite but nothing less exciting than Travel and Adventure! In Key West, the world smiled and I smiled back, ready to

lick the world or to make friends with all of it at a moment's notice. The best of everything was none too good to suit me and the worst was none too bad to bother me.

During the five days at Key West, following a delightful trip on one of the Mallory liners, I lived at the best hotel in town and casually mentioned to one or two of the gentlemen with whom I became acquainted that I was waiting for my yacht and that we were going to take a cruise around the West Indies; whereupon I found that even Key West has its financial pirates. One man of about middle age decided to take me under his wing and show me around. He dined me and would have wined me, but I did not indulge at the time. He was a very smooth article and kept me busy making evasive answers to his pointed questions concerning my finances, family and the like. He unfolded a great plan for making a fortune in a jiffy and let me know from time to time that he had



HINDU SNAKE CHARMERS AND FAKIRS AROUND IN PORT OF SPAIN

The weird music of the pipes of these snake-charmers in Trinidad is of a variety never to be forgotten



confidence in me, sought my judgment, as it were, and almost succeeded in swelling my head beyond the limits of the Panama hat I had purchased. My wardrobe was complete enough to allow me to accept his invitations to a dinner or a dance at this home or that club. Key West, in short gave me a reception that was not half bad. I was alluded to as a friend of the Duke of Sutherland, a claim I had never made, but didn't deny because I didn't have the heart to ruin all the fun these folks were having entertaining a "friend of the royal family."

Many of them begged me to offer the Duke free reign in their homes for the time he was to be in Key West; several tried to coax me to give up my room at the hotel and accept their hospitality during my stay. In saying that I knew the Duke would be grateful for their kind offers, but that I felt sure he had made arrangements which it would be difficult to change, I felt that the truth was not being transgressed; and my thanks for the offer to me was always followed by a refusal.

Mr. Van Wicklen, the financial gentleman, soon took it upon himself to ward off any more such offers for me, saying that he was entitled to first consideration and that I had repeatedly refused him.

Eventually the yacht came in, and by dropping out a back window of my hotel and going down the fire escape I managed to evade the few who had come to have me take them aboard the yacht. I hired a launch to go out and introduce myself to the Captain. As we drew up to the port gang-plank, another launch left from the starboard side, and from a vantage point on deck I saw the Duke and Duchess of Sutherland leave for the shore and to take a train back to the North. That is as near as I ever came to those good people. To my great relief, I found from the Captain that we would tarry but a few hours in Key West. We were to wait for the Count and Countess Szechenyi, who had chartered the yacht from the Duke. It was well for me to begin immediately to install the radio equipment.

The Captain and I went over the vessel to-

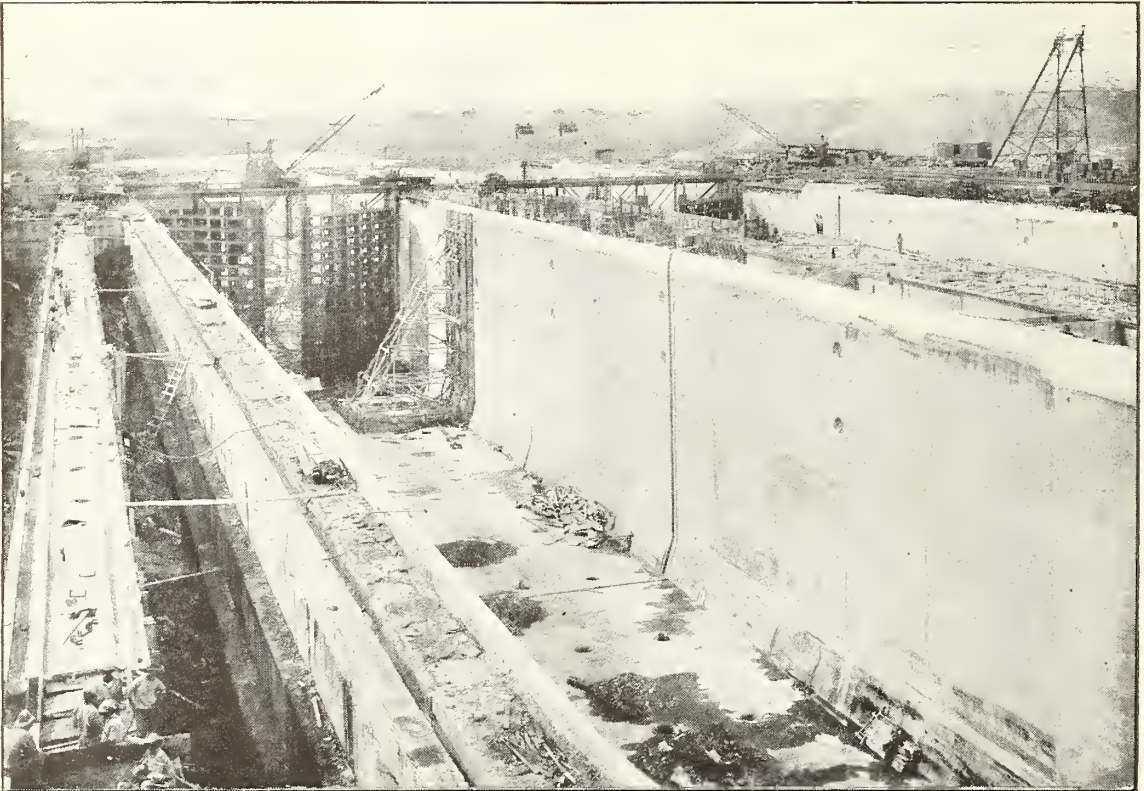

ON THE HIGHEST OF THE THREE LOCKS AT GATUN, PANAMA

Where American engineers fought every form of tropical disease in completing one of the largest "jobs" the world has ever seen. The Chagres River may be seen in the background. Just beyond the farthest horizon lies the Atlantic



gether looking for a suitable room to use for the purpose. A chat with the Chief Engineer, a good-natured Scot, revealed that the ship's generator was rated at 5K. W. and delivered a voltage of 35. Great Caesar's Ghost! I saw my trip being taken away from me. Someone had bungled—for the outfit I was to install was designed for use on 110 volts and even though the voltage had been correct, the poor little dynamo on the yacht could never have stood the load. There was only one thing to do and that was to get the ten-inch spark coil from the radio school at Key West and use it to transmit. The local manager refused to let me have it, however, and it was too late to get anything from New York. I visited several amateurs in an attempt to purchase a transmitting outfit, but could find none that was powerful enough.

All that day, with the assistance of the local manager, I worked erecting an antenna and installing a receiving set. That night I had something to tell the Captain confidentially. He agreed to the plan I unfolded, put two men in my charge, and sent us ashore in the tender. Once ashore we made for the radio school, and cracked a pane of glass out of a window, which we then unlocked. One man climbed through and it was then easy to open the automatic lock on the door and let the rest of us in. With the aid of a flashlight we found the object of our search, the treasured coil, and wrapped it up in burlap.

Then we returned to the yacht. It was an easy matter to put a sending key in series with the electric light line to operate the coil and there we were, all ready to go. I went to bed—and the next morning, when I woke up, we were in Havana Harbor.

During the day I was too busy shopping for



#### WHEN YOU STAND ON MORRO CASTLE

On one of those brilliant, peaceful, tropical days; with the Cuban flag snapping in the breeze above you and small craft cutting the blue Caribbean far below—it comes over you with a thrill that you wouldn't be anywhere else and you wouldn't change jobs with any man

white uniforms to reflect much upon my recent activities, but in the evening when I had a chance to review the past week, I wondered what had happened in the radio school when they found that the place had been burglarized. I chuckled as I wondered what Mr. Van Wicklen said upon finding that the Western Union messenger had paid my bill at the hotel and ordered my luggage sent aboard the yacht.

Havana Harbor and Havana! I thought of all the stories I had read and heard of that wonderful city. Many a time and oft had my algebra teacher held me up to ridicule before the class for reading a book of travel held between the bottom of my desk and my knees, instead of paying attention to a dissertation on

the value of X. I'm afraid X never appeared very valuable to me. Some of the tales I had read must have been written many years before, because I found it difficult, when traveling about the city, to locate any of the haunts I had read about.

The Chief Engineer's son was a chap of about my own age, and we went out to see Havana together. A military band played in the Plaza that night and a cosmopolitan gathering walked and talked and listened with languorous enjoyment.

We walked down the Prado, where Cuban beauties strolled in grandeur, for the edification of us passers-by, and the children amused themselves with roller skates and velocipedes. We dropped in at a cabaret called "The Black Cat" and saw, among others, a great many Americans of the race-horse-following variety. Then we sauntered on to the bandstand where a great crowd sat in the moonlight and listened to the music. Flivvers and limousines whizzed by; voices sang or called out gaily; and small craft made their way in and out of the harbor. No worry, no hurry—nothing to do but take in everything with grateful eyes and ears—and be glad to be alive.

On our way back we stopped in a soft drink establishment and watched a native skin a pineapple, cut it in chunks, put it in a thing that looked like a chemist's mortar, beat it to a pulp and strain the juice off into glasses for us. It was delicious. To attempt to tell you of the wonderful sights of Havana, from the Country Club to the race track, from Miramar to the Municipal Wharves, would be foolhardy. I think you'll have to go there. . . .

Following our two days' stay at Havana, we went around the north coast of Cuba to a small town called Nuevitas. We were told that tarpon fishing in Nuevitas Bay was good. It certainly was. Even as a schoolboy, I could never wax enthusiastic over fishing, for there never seemed to be enough action in it, but there is fishing and FISHING. In Cuba I was given a taste of the latter.

At night we hung a cluster of lights over the rail near the gangway, then threw bits of meat and bread into the water. In a few seconds what appeared to be dozens of large silver-hued fish were scrambling for the food. When they gathered in numbers this way, one of the quartermasters would hurl a harpoon at them.

Every hurl usually meant a fish. But catching fish is one sport, and catching tarpon is another. With a harpoon right through one of them he would swim first in one direction then dart in another, then shoot six or eight feet in the air, going through all sorts of contortions to break away. Some of them would bite fiercely at the bronze cable that held the harpoon to the line. A large tarpon would require two or three men to pull him in unless he was "played" and playing such fish with a line and rod is a very, very different game from snagging sunfish with a worm and a bent pin.

After a few days' sport at Nuevitas, we dropped in at Jacmel, Haiti. We were going to go to Port au Prince but an insurrection there caused a change in our plans. Anyway, it could hardly have been more interesting than Jacmel. Voodooism is still an active cult among the Negroes of Haiti, and a part of the ceremony connected with this particular form of worship includes offering an occasional human sacrifice. One of these celebrations, if you will, was well under way when we arrived.

Those engaged in the festivities were bedecked in all manner of weird costumes. Nondescript and informal paraders followed a number of seemingly self-appointed leaders in a riotous march through the rows of huts that made up the town. Each of the leaders carried a large staff, dangling from the top of which was some part of the sacrificed unfortunate's body.

Jacmel is on the slope of a hill and is one of the dirtiest places it has ever been my privilege to see. Open sewers ran through the main streets and—but what's the use! I'm afraid Jacmel cannot be remembered as being particularly fragrant.

Our next stop was made at Kingston, Jamaica, where one could not help being impressed with the tropical beauty that makes so fitting a frame for the spotless city that a few years before had been wrecked by an earthquake. Our tender slipped alongside a little wharf at the foot of the public market and we were immediately surrounded by a crowd of Negroes who beamed at us as they offered mangoes and alligator pears (that is not the correct name, but it is the one most used) and tobacco made up into rope, and strings of bright colored beads made from berries and beans. These Negroes, who spoke with a pro-







THE ALLIANCA—FIRST LINER TO GO THROUGH THE GATUN LOCKS

"Although you may not recognize me," writes Mr. Henry, "I am on the boat deck in the picture—sailed a few months later on this cruise as operator. We have let go the lines from the 'electric mules' and are headed for Gatun Lake"

nounced English accent, were politeness personified, despite their attempts to sell us more than we could carry.

But in telling you of this trip I have failed to mention the fact that I did a certain amount of radio work. Among other things—very few others—I copied press from the German station at Sayville, Long Island (SL) each night and banged it out with a few carbon copies on a Corona borrowed from the Countess. The time signals from NAA, Arlington, were a revelation to the Captain, and he was delighted to have the weather reports which came in twice a day. In mentioning the radio outfit, I cannot refrain from telling you of a record made with that purloined ten-inch spark coil. To my knowledge, it has never been beaten and is seldom approached. While we were in Santo Domingo City, the Count wanted to arrange for a railroad car for some friend, and requested a message sent to that effect. The radio station at Santo Domingo (SD) was out of commission at the time, owing, I was informed, to an enterprising operator's having departed with part of the equipment—and after attempting to reach Guanica, Porto Rico, without success, I was surprised to hear P,

the old spark station in the Isle of Pines, south of Cuba, tell me to go ahead with my message. I did, and he sent me an OK. In a few minutes I heard him send it on to M (Morro Castle, Havana), but I could not hear M. The air-line distance to the Isle of Pines was 480 miles—a long way to bat with a ten-inch coil and a crystal receiver, *in daylight*. That night the reply to the Count's message was among those sent broadcast by SL.

Upon leaving Jamaica, we went north again, as far as Santo Domingo City, and arrived just in time to witness the annual ceremony at which the natives carry the bones of Columbus through the streets.

In mentioning the next few places we stopped, it may be well for me to quote a letter from Rosea, Dominica sent while making the cruise:

You must be having a wonderful time with all the trolleys and traffic tied up by snow. Last night I received a report from Sayville, saying that you have had the worst blizzard since 1888. Here the summer attire we are now wearing is frequently too heavy for comfort.

We stopped in at Basseterre, St. Kitts, long enough to have a look around and mail a few post cards.





BALBOA'S PACIFIC, FROM THE SUMMIT OF ANCON HILL ABOVE PANAMA CITY

Just to the right is the Pacific entrance to the Canal. Mr. Henry says he will never forget this scene; and the incident of the flag-pole, which he describes, tells one reason why

Then followed a glorious run through the Virgin Isles. These islands are composed of lava and brimstone thrown up by some volcano, now extinct or sleeping.

Every time we set foot ashore, we are set upon by a band of blacks who hover around, begging pennies. I don't wear a uniform or carry a sign, but someone in the band is bound to single me out and tell me they have some nice things to show the "wireless." The "nice things" they have to sell usually amount to little more than a few woe-begone post cards or a poor-grade Panama hat.

From here we go to Martinique, St. Lucia, St. Vincent, Grenada, Trinidad, La Guayra, and Curaçao. With such an itinerary before us I can't help feeling like a millionaire—this is the life.

And it *was* the life!

Each one of the islands and towns had an individuality, but the one that made the great-

est impression upon me was St. Pierre on the island of Martinique, for here twelve years before, fire and brimstone from an active volcano had wrought havoc with the little town. Many of the battered walls were still standing. Great crevasses could be seen in the hillsides, caused by the burning lava as it flowed toward the sea. The natives tell of three vessels, lying at anchor in the harbor when the eruption took place, which were demolished, and how at certain times they appear again in phantom form, lying at anchor in the harbor.

One incident, which you will agree is enough to stick in a fellow's memory, occurred in Fort de France. Several young natives had paddled their little boats out to where we were at anchor, and we had been having great sport watching them dive for coins thrown into the



water. The water was so inviting that I decided to have a little swim myself, and inasmuch as my clothing was light, I dove right off the gangway and was soon having as much fun as the little coal-black roses. My attention was attracted by several people on board rushing to the rail, shouting and gesticulating wildly. I thought something had happened on the ship and that I was wanted in a hurry, so I made for the gangplank. As I approached it, two sailors who had rushed down, grabbed me by the arms and whisked me out of the water. I looked back into the water and saw several huge shark-fins in silent retreat.

Following a short stay at La Guayra and Curaçao, we went to Colon, Panama. There we had a mighty fine look at the greatest engineering undertaking in the world. Little did I imagine at the time that a few months later it would be my good fortune to be on the first ocean liner to pass through the Gatun Locks.

In Colon, I met a friend who was Radio Officer on a Panama Liner and he arranged for a railroad pass to Panama City for me. Among a million and one other things I saw the locks

at Mira Flores and Pedro Miguel and climbed up Ancon Hill, which is just above Panama City. Not satisfied with the wonderful view of the city and the canal and the Pacific that this vantage point offered, I climbed to the top of a topographical tower and then shinned up the mast to the cross tree, used to hold the red cloth marker. When I had almost reached the top, the mast snapped, and I fell to the upper platform, suffering no further injury than a huge rip in the seat of my trousers, which had caught on the projecting part of the mast. A pair of khaki trousers from a local shop relieved the only embarrassment caused by the fall.

From Panama we made another stop at Kingston, to take on coal, and then returned to Key West by way of the south coast of Cuba. Here, I dismantled the radio equipment, returned the coil I had stolen from the school there and said good-bye to the good yacht *Catania*.

The only people in the world who can take a trip of this sort are millionaires and radio men. The radio game is surely worth the candle.



#### OFF FOR A TRIP AROUND THE WORLD

Peter Taylor, radio man (with cap); his sister, Mildred Taylor, writer (in the car); and Blanding Sloan, artist (not shown) left City Hall, New York, on April 26th for a trip to the Orient and around the world. The radio set, an important part of the travelers' equipment, was stowed on the port side of their car. Among other things, the trip will be productive of articles and photographs concerning radio in other lands, which will be prepared especially for RADIO BROADCAST.

Arthur H. Lynch, (at Mr. Taylor's right), Editor of RADIO BROADCAST, joined in seeing the party off

# A Home-Made Amplifier for Any Receiver

By ZEH BOUCK

Many owners of single-tube sets who have considered adding audio-frequency amplifiers are prevented from doing so either because of the expense or because they have the idea that a two-stage amplifier is a difficult piece of apparatus to construct or handle. An inquiry into the prices of the necessary tubes, sockets, transformers, etc., will allow you to settle the cost question for yourself. This article will show that the second obstacle—difficulty of construction or operation—is somewhat of a myth. It will show you not only how to make a two-stage amplifier from standard parts, obtainable from any good radio dealer, but also how to use it to best advantage with the receiver you already have. And even if you are using or expect to use, a bought amplifier, Mr. Bouck's tips on the proper connections may put the breath of life into a "dead" set, or improve a set that is not quite "hitting on all cylinders."—THE EDITOR.

**C**ONSIDERABLE uncertainty exists in the minds of many enthusiasts as to the operation and application of audio-frequency amplifiers, probably the most simple and most standardized of audion circuits. The impression of complication is due, for the greater part, to the general misconception that different tuning circuits require different systems of amplification. This idea is altogether at variance with fact, for the A.F. amplifier is a *unit* that can be added to *any* receiver without varying the connections to the amplifier. However, it is sometimes necessary, for greater simplicity and B battery economy, to alter slightly the plate circuit

connections of the receiver proper. The majority of unsuccessful attempts at adding audio-frequency amplification, particularly to the "Parker" circuit (Fig. 1) and the Peterson "Automatic Regenerative" circuit (Fig. 2), have been due to the failure to re-arrange the positions of the B battery and phones.

Changing the sequence, or varying the relative positions of different pieces of apparatus in a circuit, affects neither the circuit nor its operation, while it may greatly facilitate the addition of auxiliary equipment. (The fan should familiarize himself with the fundamentals of important circuits in order that he may recognize them camouflaged by the eccentricities of individual experimenters.) For example, in a single bell ringing circuit, the electrical position of the push-button is immaterial in so far as the operation of the bell is concerned. However, if more bells than one are to be operated from the solitary push-button, it must then be placed in a lead common to all bells. In a single-bulb receiving circuit, the position of the B battery is unimportant as long as it places the required positive charge on the plate and the current passes through the telephone receivers. But when amplification is added, the position of the battery must be such that it may impress its potential *across all the tubes*.

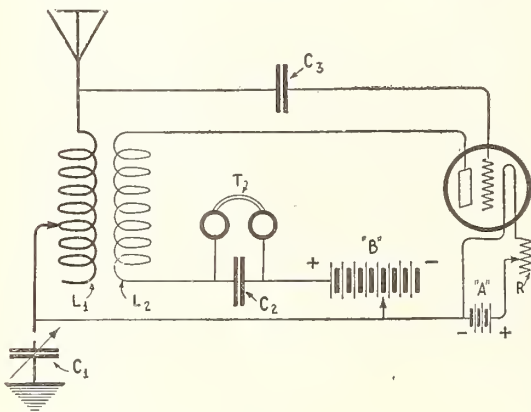

FIG. 1

Experimenters endeavoring to add amplification to this circuit have run up against many difficulties, including the burning out of tubes and the shorting of high-voltage batteries. In this case, the voltage taps are taken on the wrong side of the B battery. C<sub>1</sub> is of .001 mfd. capacity, C<sub>2</sub> is a telephone condenser of .0025 mfd. and C<sub>3</sub> is a grid condenser of .0005 mfd.

## EXAMINE THE B BATTERY CONNECTIONS

**I**N ARRANGING a receiver for the addition of audio-frequency amplification, it should be first determined if there are any instruments between the A and B batteries, such as telephone receivers, variometers and plate



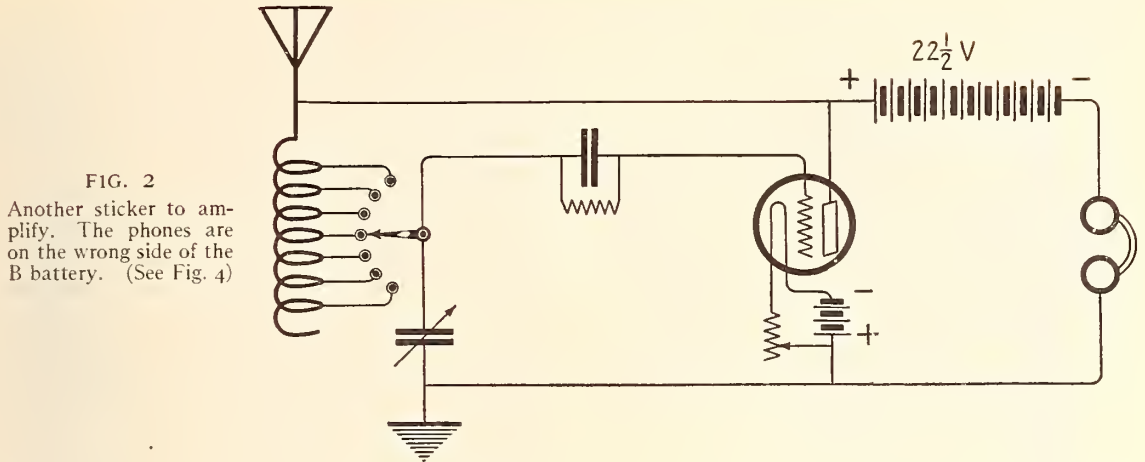

FIG. 2  
Another sticker to amplify. The phones are on the wrong side of the B battery. (See Fig. 4)

tuning devices. Figs. 1 and 2 show circuits with this (undesirable) arrangement. Such inter-battery apparatus should be moved to the plate side of the B battery, and the latter connected directly to the filament lighting source. Fig. 3 and 4 show practically the same circuits with the changes made, and to which amplification may be added without more ado.

The standard amplifying circuit is shown in Fig. 5. The required instruments are plainly indicated on the diagram, and are carried by any well stocked radio supply house. In securing the apparatus the experimenter should be satisfied with only the best obtainable. This applies, not merely to tubes and transformers, but equally well to sockets,

rheostats, and jacks. The unsatisfactory operation of home-made amplifying apparatus is due, in the majority of cases, to defects in mediocre instruments which give rise to distorted and noisy amplification. The leads on the transformers should be examined, in order to determine which wires run from the outside of the primary and secondary windings (ends farthest from the core). These leads should connect, one to the plate of the preceding tube (the outside lead of the primary) and one to the grid of the succeeding tube (the outside lead of the secondary). This correct disposition of the transformer leads is a factor which contributes greatly to the success of the amplifier. Jacks one and two are double-circuit jacks, while the third may be of the

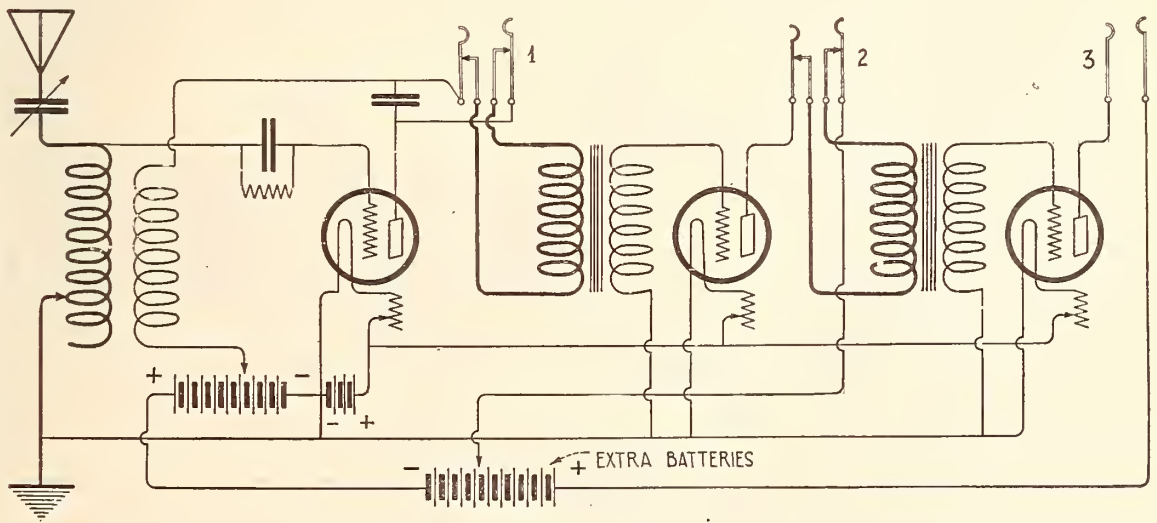

FIG. 3

This is Fig. 1 with slight alterations and the amplifier connected in the proper way

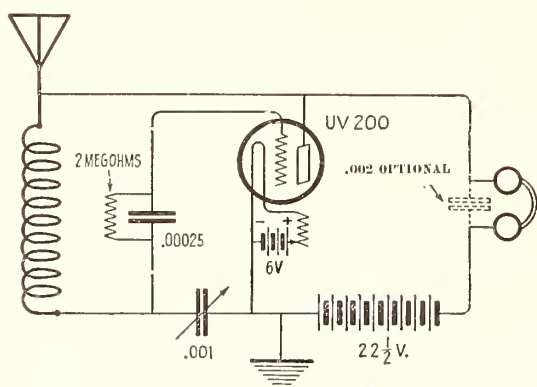

FIG. 4

This is Fig 2 corrected and ready for amplification

open-circuit type. The condenser across the input is a small fixed capacity of approximately .0015 mfd., commonly called a telephone shunt condenser. It is possible that such a condenser already exists in the enthusiast's unamplified receiver, and if such is the case, an extra capacity is not required.

The connections of the various instruments should be made with hard-drawn wire of a size not smaller than number eighteen. The wiring should be well spaced, and needless to say, every joint soldered. Particular care should be taken in making clean and firm connections to the jacks. Use the least amount of flux necessary to effect a perfect joint, and any superfluous acid or paste should be removed by wiping with a rag dipped in wood alcohol. Bungled soldering on the jacks is the cause of seventy-five per cent. of "tube noises" in audio-frequency amplifiers.

The additional B battery should be of at least 40 volts, which, when connected as indicated to the detector plate supply, will place a potential of some 60 volts on the amplifying tubes. This is generally a minimum voltage for satisfactory amplification. Still greater intensification will be had on voltages in the neighborhood of one hundred, though distortion will be more marked. The use of a power tube in the final stage of amplification will

often improve the quality of amplified speech. Voltages in excess of 100 seldom give satisfactory results on ordinary amplifiers, and should in general be avoided as it sometimes happens that this voltage results in burning out the transformer secondary.

The construction of the amplifier, while not a difficult matter, should be undertaken by the fan only after he has had the experience of building an efficient single-bulb set. The mechanical details of a popular form of construction are shown in Figs. 6 and 7, and the dimensions are approximately indicated. The panel should be of bakelite, hard rubber or a similar insulating material at least one quarter of an inch thick. The instrument shelf may be of the same material or of unpainted wood. There are several ways in which this last may be mounted, and many amateurs make the jacks do a double duty by utilizing them as supporting brackets for the shelf. This, however, subjects the panel to considerable strain, and the writer recommends the use of wooden blocks or small brass brackets. These are screwed to the panel at such a height that the tops will be on a level with the tops of the jacks (Fig. 6), which will lend an additional support to the shelf without endangering the panel. The wooden blocks should be as large as possible without being cumbersome and interfering with mounting and wiring. The small insert in Fig. 7 indicates the preferred method of mounting the sockets, transformers, etc. The cores of the transformers are placed at right angles to each other in order to reduce the possibility of inductive feed-back and

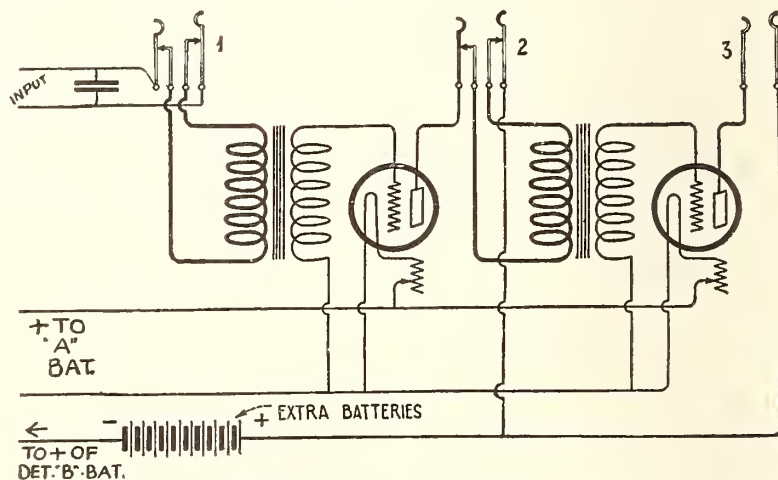

FIG. 5

The standard amplifying circuit for connection to any receiver



howling. Binding-posts on the shelf are also provided for connecting the batteries behind the cabinet.

PREPARING THE PANEL FOR DRILLING

THE panel may be drilled at an electrical or machine shop at a very small cost, and many supply houses perform this service gratis for customers who purchase from them the apparatus required in the construction of the amplifier. In preparing the panel for professional drilling, the positions of the holes should be carefully laid out and center-punched. The panel should be accompanied by a rough sketch on paper showing the locations and sizes of the holes. Excepting for the peep-holes, and those passing the rheostat shafts and jack shanks, the holes may be drilled for the passage of a No. 8 screw. This will permit the use of comfortably large wood screws, and in the case of smaller machine screws, will allow for slight inaccuracies in drilling.

If the experimenter possesses a small hand-drill, the panel work may be done on his own bench. However, he will probably find that

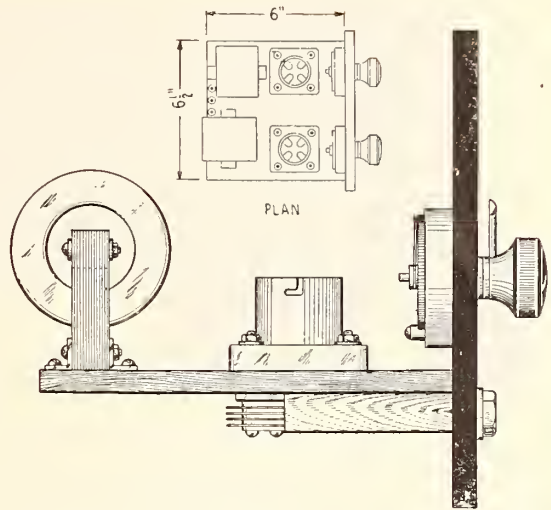

FIG. 7

Showing the preferred method of mounting the shelf and instruments behind the panel. Note the transformers at right angles to each other

the large peep-holes present somewhat of a problem. This is most easily overcome by making a group of small holes arranged symmetrically.

Before building the amplifier, the fan will do well to examine some commercial amplifier of reliable make.

The amplifier described is connected to the receiver by effecting the indicated battery connections (Fig. 5) and by connecting the input wires in place of the telephone receivers. These last should be wired to a standard plug fitting the jacks.

The experimenter need not build the two stages at one time. Even a single step adds greatly to the enjoyment one may derive from a receiving set, and it often makes possible the use of a loud speaker on near-by stations. In adding a single stage of amplification, the second transformer and tube are eliminated from Fig. 5, and the remaining connections made as indicated. A one-step amplifier will give an average signal intensification of five to twenty times, while two stages will multiply the sound of the detector output from one hundred to four hundred times.

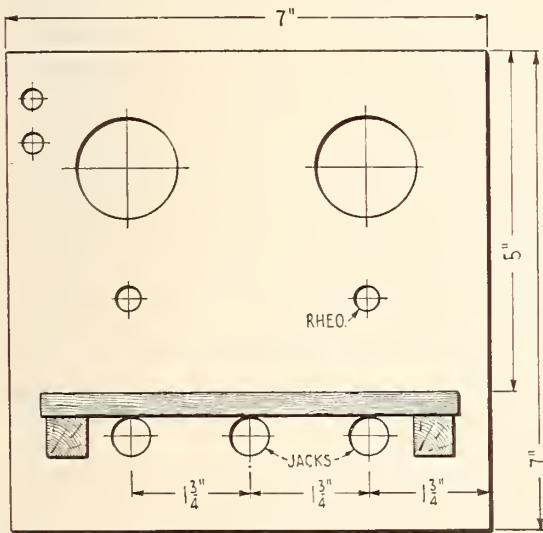

FIG. 6

Indicating the approximate dimensions of the panel and the positions of holes



# How Far Have You Heard?

On Any Number of Tubes

2500-mile reception has been achieved by two contestants, with home-made apparatus



Reports from all over the country indicate that our second "How Far Have You Heard?" Contest has created a great deal of enthusiasm.<sup>1</sup> Inasmuch as this issue goes to press before May 31st (the date the contest ends), it is impossible to declare the winners or to print some of the best reports; but the winners will be announced next month, and their articles, as well as others of particular interest submitted in the "How Far?" Contest, will appear in the next and subsequent issues.—THE EDITOR.

## A 5-Tube Receiver that "Delivers the Goods"

By E. D. HARRINGTON

**B**ECOMING dissatisfied with a crystal receiving set, as most broadcast listeners do, I became more and more determined to build for myself an audion set that would satisfy the most exacting person. I began by reading available data and articles published on vacuum tubes, condensers, transformers, aerials, etc., and when more or less assured that I understood the underlying principles of radio reception, I began building my set. My observations and studies had soon assured me that although not many were as yet using radio frequency, it was by far the most desirable, in that the results obtained<sup>2</sup> seemed easily worth the increased time, effort and amount of money.

As was to be expected, I had much trouble at first and lost many good hours of sleep puzzling over different wiring diagrams, and building various sets with all sorts of hook-ups. The result was that six months after I started, I completed the set I am about to describe. In

my opinion, it is very satisfactory, quite different from the crude single-tube affair that was my first attempt. The set is selective, capable of bringing in clearly many distant stations, and has enough power to fill the whole house with music when using a Type C Baldwin phone at the end of a three-foot lacquer horn. The lacquer horn is superior to metal in that there is no metallic sound to the music heard through it. Another improvement in the quality of the music may be had by melting a very small drop of sealing wax over the pin through the center of the diaphragm of the phone. This tends to lessen any tendency of over-vibration, and will also keep the pin tight in the diaphragm.

The set is of the spider-web coil type, consisting of two stages of radio frequency, detector, and two stages of audio frequency. All controls, rheostats, condensers, coils and potentiometers are mounted on a panel of  $\frac{1}{4}$ -inch hard rubber, 9 inches high and 26 inches long, completely shielded with .002 brass. All the instruments on the panel are well insulated from the shield, and the latter grounded to the ground lead. A series-parallel switch is used in the antenna circuit to switch the aerial condenser from series to parallel for long-wave reception, and a like switch is used to cut the radio frequency in or out as desired. The latter switch is necessary for the reception of signals

<sup>1</sup>This Long-Distance Receiving Contest, held to determine who has done the best work with any number of tubes and any kind of receiver, was explained in full, with a list of prizes for winners, in the March, April, May, and June issues of RADIO BROADCAST.

<sup>2</sup>With the set described, Mr. Harrington has heard 16 stations more than 1000 miles from his home (Berkeley, California) including 6 more than 2000 miles away. His greatest distance is WJZ, Newark, N. J.—2550 miles.



of more than 600 meters, as the R. F. transformers will not handle waves over that length. Separate B batteries are used for the radio and audio frequency, but a single 6-volt A battery is used for both. Jacks for the detector and each stage of audio frequency are supplied for use on signals from stations close enough not to require the full power of the set. This saves the batteries and tubes a little.

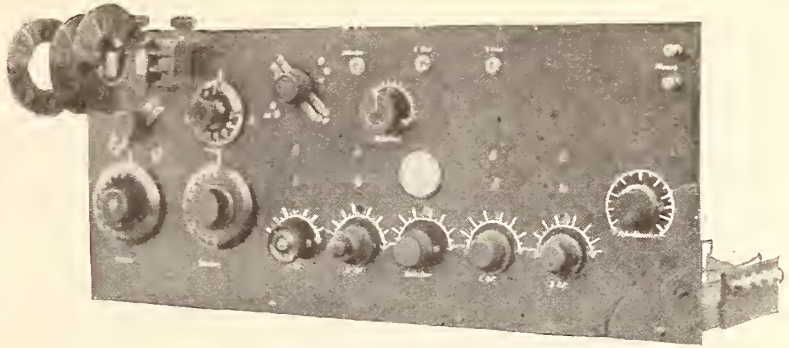

THE RECEIVER BUILT BY MR. HARRINGTON  
Whose success in transcontinental reception can be attributed,  
in large measure, to soldered connections throughout his set

The tuning is controlled by two condensers—a 43-plate variable in the primary circuit and a 23-plate variable and vernier in the secondary circuit—and two potentiometers, one used as a stabilizer. A word about condensers, both fixed and variable. From my experimenting with different kinds and makes of both types of condensers, I have discovered that those whose movable and stationary plates are very close to each other are not as practical as those having the plates a little farther apart because of the fact that dust particles are floating in the air at all times, and some of these settle on the plates of the condensers. In time, enough of these particles may collect so as to cause some of them to touch each other as the plates are moved, thus causing a discharge between the plates of the condenser, the dust particles acting as a high resistance conductor. If this should happen, the set would become very noisy and would cut its efficiency very materially; so, for this reason, encased condensers are best. Due to the fact that there are no spring contacts to come loose or to wear out, variable condensers whose plates are balanced have been found to be more efficient for longevity and hard use. Another important thing is the selection of fixed condensers. Paper-insulated fixed condensers are liable to puncture if high B battery voltages are being used, and when this happens it sounds as if all the arc lights and X-Ray machines in the community were inside the set! From some few experiences like the above, I have found that mica-insulated fixed condensers are more satisfactory.

The tubes are mounted in cascade, back of and about two inches away from the panel. They are placed behind their respective rheostats so as to keep the leads from the latter as

short as possible, and all the connections are soldered. Too much stress cannot be laid upon the importance of soldered connections. *All* joints and connections, leads to transformer and socket binding posts, battery binding posts, etc., should be soldered. There will be no "rock-crushers" or "stamp mills" in a set so connected. In order to keep their leads as short as possible, the transformers are set directly behind the tubes, and have their cores at right angles to each other. The transformers are separately shielded and the shields grounded. A C battery is used to impress a heavier negative charge on the grids of the amplifier tubes in the audio frequency, and this tends to cut out distortion and also to increase the volume of the signals. The voltage used here is varied to get the best results, sometimes being as low as  $1\frac{1}{2}$  volts but never over  $7\frac{1}{2}$  volts. 90 volts on the plates of the R. F. tubes, 18-23 on the detector, and 90 on the A. F. amplifiers bring the best results.

Two outside aerials are available for use. One, a 5-wire inverted L, 44 feet long and 65 feet high with a fan shaped counterpoise containing 350 feet of wire is very efficient on the more distant stations. The other, a single wire 165 feet long, 65 feet high at one end and 50 feet at the other, works very well on the local and near distant stations. The leads in are taken from the higher end and are as short as possible. For reception up to 500 miles, where great strength of signals is not desired, a loop aerial is used. With it the set becomes ultra-sensitive. Music from stations 300 miles away using a reasonable amount of power output in their aerial, comes in strong enough to operate the Baldwin phone and be heard over the entire room. Cunningham 301-A tubes are used throughout the set, and I

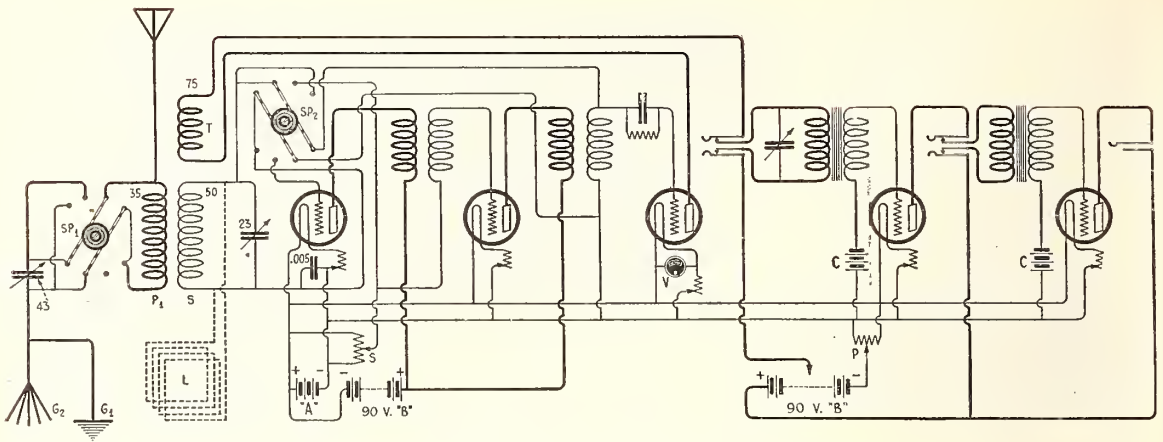

“TWO RADIO, DETECTOR, AND TWO AUDIO”

C,  $7\frac{1}{2}$ -volt batteries for biasing A.F. tube grids; G<sub>1</sub>, earth ground; G<sub>2</sub>, capacity ground (counterpoise); V, detector tube voltmeter; SP<sub>1</sub>, series-parallel antenna condenser switch; SP<sub>2</sub>, switch for cutting R. F. in or out; S, stabilizer; P, A-battery potentiometer; L, loop which may be used instead of outside antenna when desired

have found them to give very good results. These tubes are not critical as to filament voltage, although 5 to  $5\frac{1}{2}$  volts on the filaments works as well as any higher voltage. These tubes “fry” less and oscillate more freely, than any other tube I have used.

Tuning the set is accomplished as follows: for wavelengths up to 375 meters, the correct size coils are placed in the coil-mountings (about 35 turns in the primary, 50 in the secondary, and 75 in the tickler). The bulbs are turned to their right temperatures and the aerial condenser is switched to series with the aerial, and the R. F. switched in. The primary condenser is then turned to somewhere between 0 and 40 on the dial (usually about 25), and the secondary condenser is slowly rotated from 0 to maximum until a shrill whistle is heard. The stabilizer is then adjusted until voice or music is distinct and clear. Usually the secondary condenser, vernier and stabilizer must be re-adjusted slightly, and then the concert or address “picked up” may be enjoyed to the greatest extent. Moving the coils and changing the stabilizer and vernier will enable a

person to hear different stations operating on nearly the same wavelength. If the primary condenser be turned farther toward maximum and a larger coil inserted in the primary circuit, stations of different wavelength may be brought in. For 400-meter stations I have found that 50 turns in the primary and secondary, with 100 turns in the tickler give the best results, the signals being clear and loud, with a minimum of interference from 360-meter stations and amateur stations. Flat-wound pancake coils seem to give quite the best results.

In the short space of the half-hour in the evening while local broadcasters are quiet, I have been able to tune in as many as 18 different stations. Those within 500 miles may usually be brought in while local broadcasters are in the air, with no interference from the latter. This is especially true when using a loop aerial. The loop used with this set is two feet square and has twelve turns of wire.

In conclusion, I will say, that for one who wishes a set that is sensitive, selective, powerful and easy to operate, this set gives great satisfaction.

## REPORTS FROM OTHER ENTRANTS IN THE “HOW FAR?” CONTEST

FINE WORK FROM A REMOTE CORNER OF THE U.S.

MR. LESTER WITHERBY, who lives in Ferndale, Washington—a hundred miles north of Seattle, near the Canadian border, has done some remarkable receiving with a 3-circuit two-bulb set, for which he wound his own

multi-layer coils. His list of stations is too long to publish here, but his three greatest jumps are WGY, Schenectady, N. Y., 2,500 miles; NOF, Anacostia, D. C., 2,475; and KGU, Honolulu, 2,300.

Mr. Witherby has supplied the following “dope,” which, with the photo and circuit



diagram shown, should enable the experienced radio fan to build a similar set (the 3 coils and coil mounting may, of course, be bought if desired):

"My set is a home-made one and consists of a detector and one stage of audio-frequency. It is mounted on a bakelite panel 6½ inches by 15 inches.

"I use three honeycomb coils of 35, 50 and 75 turns each, in the primary, secondary and tickler respectively, with a 43-plate vernier condenser across the secondary coil.

"The only thing to bother about my set was to get it to oscillate on 400 meters without an extra amount of current on the detector. To overcome this trouble, I placed a .001 mfd. fixed condenser across the primary of my amplifying transformer which helped considerably in cutting down the filament current.

"I made my own honeycombs and also the mounting, which is similar to a Remler mounting except that the contact is made with spring brass clips instead of brass plugs.

"In tuning, I set the coils nearly closed, get the wave with the condenser, then tune in clearly with the vernier condenser and vernier rheostat. One thing that gives me lots of volume, and very little noise is a large-ratio (9 to 1) transformer.

"My aerial, about 30 feet high and 150 feet long including lead-in, is made of the copper ribbon from the field coil of a Ford magneto. It works fine because of its extra surface.

"The set is wired with No. 14 copper wire, and all joints are soldered.

"All measurements for mileage were taken on a Rand-McNally & Co. copyrighted map. This map checked closely with Cram's official radio map.

"Being located in the very northwest corner of the United States and therefore unable to get any stations north or west, I consider my aggregate mileage better than the same mileage at some central point. Some stations, such as Atlanta, Birmingham, New Orleans, etc., are as far from Ferndale as they are from any place in the United States."

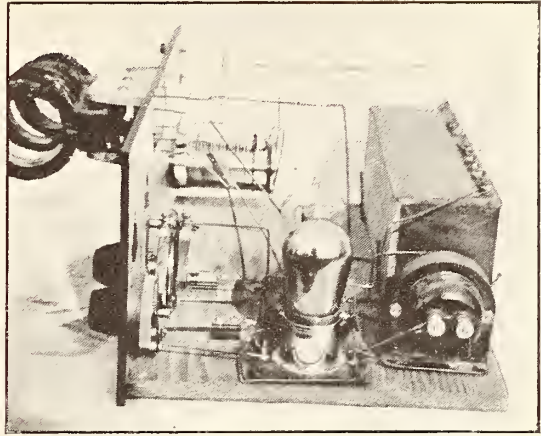

MR. WITHERBY'S SET IS SIMPLE  
But it has reached out 2500 miles

YOUNGSTER AMONG THE LEADERS

ROSCOE ROBINSON of Ponca City, Oklahoma, who is but fourteen years old, has run up an aggregate mileage of 93,475. He uses a Murad Type MA-13 receiver with a loop antenna. Among the stations he hears are KHJ, Los Angeles, Calif., WGY, Schenectady, N. Y., WF1, Philadelphia, Pa., PWX, Havana, Cuba, KDZT, Seattle, Wash., CKKE, Toronto, Ontario, WDAL, Jacksonville, Fla., KUO, San Francisco, Calif., CJCE, Vancouver,

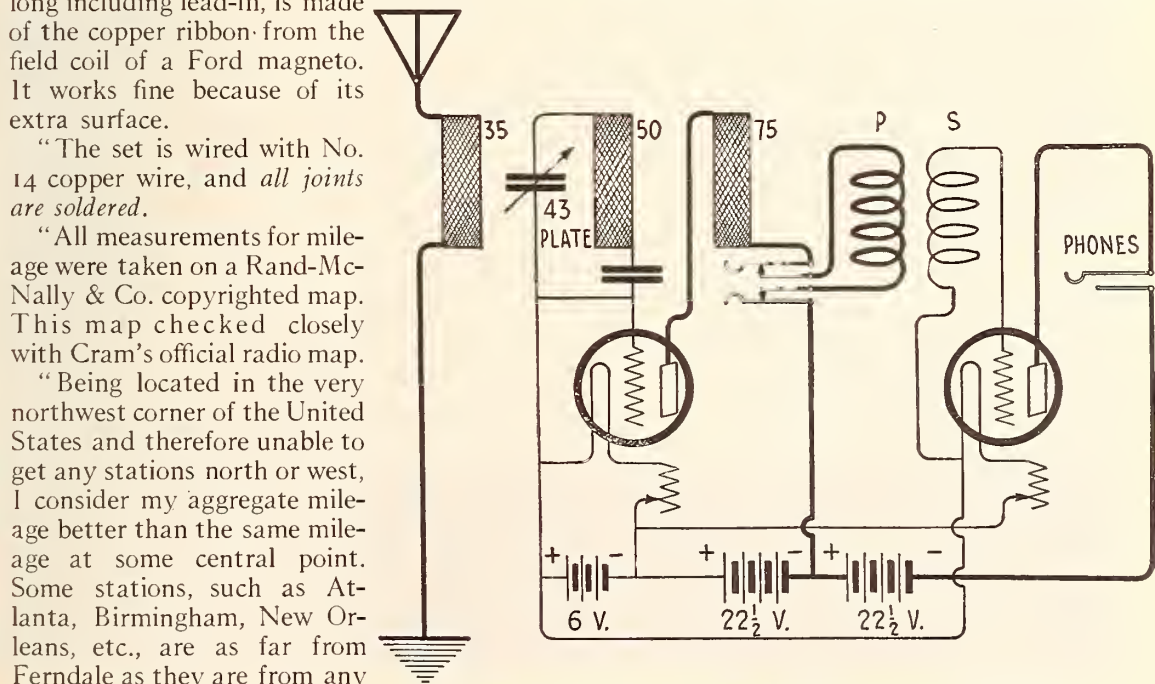

MR. WITHERBY'S HOOK-UP—A GOOD ONE TO TRY

B. C., and WGAD, Ensenada, P. R. He has included no stations within 150 miles of his receiving station, and Ensenada is his best single jump—approximately 2,000 miles.

Henry Duderstadt of Kansas City, Mo. has heard 110 stations from 150 to 1,550 miles from his home, and his aggregate mileage is 69,980. Mr. Duderstadt is using a Grebe CR-9. He has listed but 7 stations less than 200 miles distant; 13, between 200 and 300 miles; 7 between 300 and 400; 20 up to 500; 15 up to 600; 10 up to 700; 8 up to 800; 5 up to 900; 2 up to 1,000; 3 to 1,100; 5 to 1,200; 1 to 1,300; 4 to 1,400; 3 to 1,500, and 4 up to 1,600. His list would make a pretty good broadcasting directory in itself and it has been sworn to before a notary.

Curtis Herbert of Rutherford, N. J. has heard 88 stations from 180 to 3,200 miles distant with an aggregate mileage of 69,501 on a home-made single-circuit regenerative outfit. His longest jump is Los Angeles, Calif. This is exceptionally good for a home-made outfit.

On a modified single-circuit regenerative outfit employing a vacuum-tube detector and one-stage amplifier, Mr. Edwin M. Nissen (Radio 9EAM) had heard 77 stations from 375 to 1,725 miles distant from his home in Denver, Colo. His list includes stations located along our Eastern seaboard, all the way from Boston to Cuba, along our southern border to the West Coast, up into Canada and back to Boston.

R. P. McElhiney of Madison, Me., has received concerts from 24 states. His receiver is a single-circuit regenerative outfit made up of standard parts. The shortest distance on his list is 200 miles and his greatest jump is 1,785, to Fort Worth, Texas. His aggregate mileage is 69,840.

Rolland R. La Pelle of Washington, D. C., using a two-tube receiver that he made himself, lists 100 stations from 175 to 2,300 miles. His aggregate mileage is 56,905 and his 2,300 mile jump is to Los Angeles, Calif.

Among the contestants who are below 50,000 is Daniel Lamb of Mesa, Ariz., who uses a home-made single-circuit regenerative outfit and has heard 39 stations from 200 to 2,300 miles distant. His aggregate is 36,950. He mentions, however, that this list is not complete and that he has only recorded some of the best distance work he has done. Perhaps the present list may be considerably increased if all his stations are included.

Alex H. McKay, of Bradford, Pa., using a single-circuit regenerative receiver and two stages of audio-frequency amplification, has heard 72 stations 150 to 1,450 miles distant and his aggregate is 36,710. His 1,450 mile hop is to San Antonio, Texas.

A. J. Wishart and L. D. Thorpe of Perdue, Saskatchewan have sent in a joint report of 34 stations from 150 to 2,700 miles, with an aggregate mileage of 30,925. They use a standard three-circuit regenerative receiver.

Miss Hazel B. Horne of Montreal, Quebec, using an Aeriola Sr. has heard 47 stations from 225 to 1,575 miles away, and her aggregate mileage is 30,070. Miss Horne has the best aggregate mileage among the ladies, and we wonder why more of them have not sent in their reports.

Mr. W. H. Croft, Saskatoon, Sask. has heard 31 stations 185 to 1,500 miles distant and his aggregate mileage is 27,035. That makes an average mileage for the 31 stations of considerably better than 800 miles.

T. J. Forgy of New Carlisle, Ohio, is using a three-circuit receiver of the type used by Mr. Bedell and described in RADIO BROADCAST for January. He has heard 44 stations from 160 to 1,900 miles distant. His aggregate mileage is 25,125.

Nelson Brown of Southampton, Ontario, also uses a three-circuit tuner and has heard 35 stations ranging from 180 to 1,500 miles. His aggregate is 20,740.

Henry S. Sherman, Jr. who is but 14 years old, uses an outdoor antenna with a spider-web regenerative outfit that he built himself. He has heard 35 stations from 250 to 1,950 miles distant. The 1,950 mile jump is KDKL, Salt Lake City, Utah and his aggregate mileage is 19,210.



A NEAT 6-TUBE SET MADE BY DON ROSS, OF IRONWOOD, MICH.



# WEAF's New Home



THE LARGE STUDIO OF THE AMERICAN TELEPHONE AND TELEGRAPH COMPANY, NEW YORK

From a control booth commanding a view of both studios, the announcer can "cut in" an artist in the small room, while an orchestra, for example, is preparing to "go on" in this one

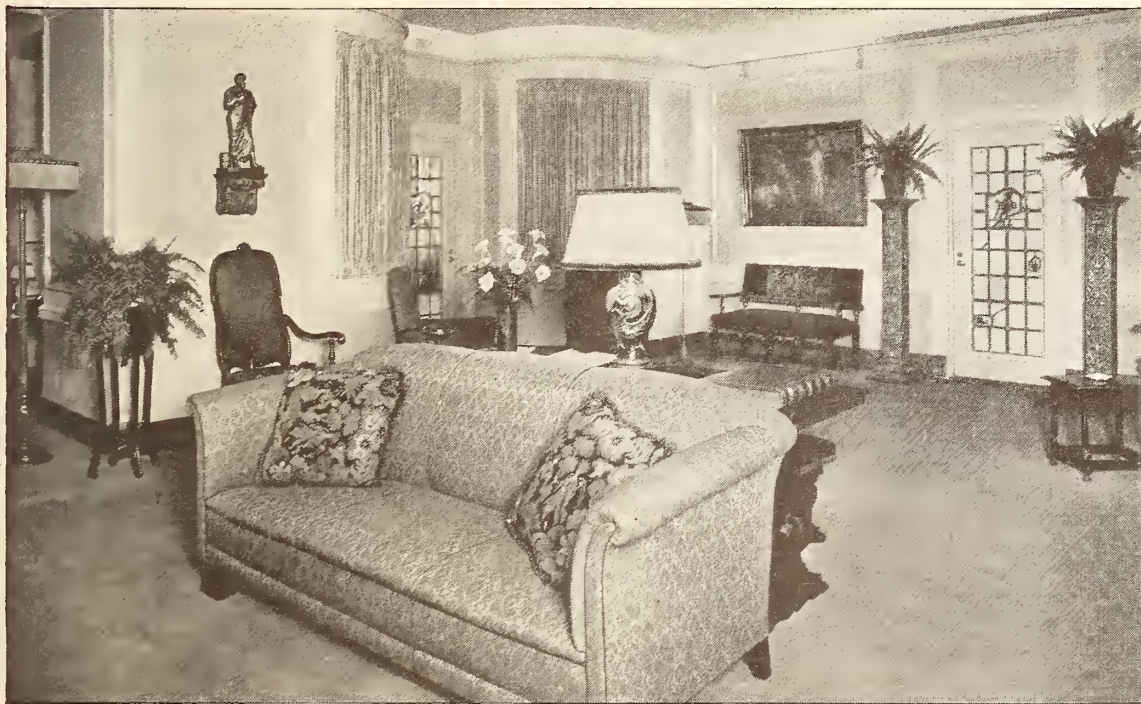

THE COMFORTABLE RECEPTION ROOM, WITH DOORS LEADING TO BOTH STUDIOS

# All Boy Scouts, Attention!

RADIO BROADCAST announces a contest, ending July 31, 1923, to determine WHAT BOY SCOUT TROOP HAS DONE OR IS DOING THE MOST WITH RADIO.

## Prizes for Winning Articles

FIRST PRIZE: CROSLEY MODEL X 4-TUBE RECEIVER.

This receiver, which may be used with dry-cell tubes if desired, consists of detector, one stage of tuned radio-frequency and two stages of audio-frequency amplification. (Advertised in RADIO BROADCAST).

SECOND PRIZE: MUSIC MASTER LOUD SPEAKER.

This is the new loud speaker made by the General Radio Corporation. (A picture and description of it appear in the advertising pages of RADIO BROADCAST).

THIRD PRIZE: THREE

The WD-11 is the well-known dry-Corporation. (Filament voltage 1.5, of the third prize may have UV-199's

A YEAR'S SUBSCRIPTION TO given as prizes for the ten next best

These prizes will be awarded to troop may delegate one of its members to



WD-11 VACUUM TUBES.

cell tube manufactured for the Radio plate voltage 22½—45). The winner or UV-201-A's if he prefers.

"RADIO BROADCAST" will be contributions in this contest.

troops, not to individuals, although any prepare the story.

## Rules of the Contest

1. Articles must be true accounts of radio with relation to your particular troop: what you have done, or are doing, or both.
2. Every article must be written by a Scout or by more than one Scout belonging to one troop.
3. Articles should be between 500 and 1000 words long.
4. Good photographs to illustrate the article will count 50% in judging contributions.
5. Typewritten manuscript, double-spaced, is desired, though not required.
6. Address contributions to Scout Contest, Radio Broadcast, Doubleday, Page & Company, Garden City, N. Y.

Scouts have done splendid work in maintaining communication by radio in time of floods and disaster, in copying and spreading the market reports transmitted by the government Farm Bureaus, in training themselves along mechanical and electrical lines, and, in short, in using radio as a part of scout work in a way consistent with the best traditions of scouting. What have you to tell of your troop's past or present activities? Get your scribes and photographers under way with that story which will put in a strong bid for first prize. How would a receiver with three stages of amplification go in your troop?

Beginning with the August number of RADIO BROADCAST, the best articles will be published. The winners will be announced in the September number, and unless the three best articles have been previously published, they will appear in that issue.



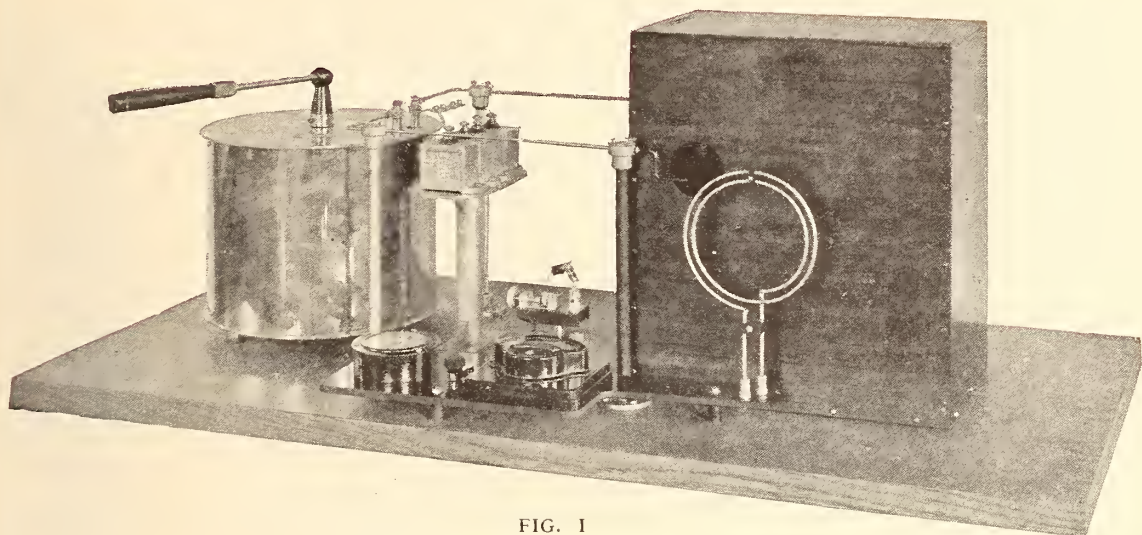

FIG. 1  
Standard wavemeter of the Bureau of Standards

## Reducing the Guesswork in Tuning<sup>1</sup>

How the Bureau of Standards Will Measure the Wavelengths of Broadcasting Stations with an Accuracy of 99.9%, Making it Possible for Any One to Use His Receiving Set as a Wavemeter

By J. H. DELLINGER

Chief, Radio Laboratory, Bureau of Standards

THE good results already appearing from the recommendations of the Second National Radio Conference could easily be wrecked if the radio broadcasting stations and other stations should not operate accurately on the frequencies to which they are assigned. One of the reasons why interference has been the great draw-back to progress in radio has been that the transmitting stations have used waves which approximated the assigned wavelength or frequency only very roughly indeed. Among its numerous tasks of standardization and research, the Bureau of Standards has devoted itself with some vigor to the task of improving the frequency standards of the country, with the result that there is every prospect that the interference situation will be greatly relieved from now on. The Bureau's work in this direction<sup>2</sup> has been directed at two objectives:

<sup>1</sup>Published by permission of the Director, Bureau of Standards.

<sup>2</sup>Among those who are engaged in this important work, under Dr. Dellinger's direction, are Mr. E. L. Hall, the Misses F. Kenyon and G. Hazen, Mr. F. W. Dunmore, Mr. F. H. Engel, and Mr. H. J. Walls.

increasing the accuracy of its standards, and making these standards available to the radio public.

About a year ago the Bureau began a program of work which would materially improve the accuracy of its radio-frequency measurement. Prior to that time the basic wavemeter standards were based entirely on circuits made up of standard capacities and inductances, the values of which were either calculated or measured at low frequencies. These standards were prepared with great care and precautions were taken to avoid errors in the measurements, but there was no certainty that the frequency basis thus established could be relied upon to be correct within less than 1 per cent., particularly for the very high radio frequencies. The work that has been done recently has given a new basis of measurement, resulting from several interesting and quite independent methods of frequency determination, and is much more accurate. The goal set in this work was an accuracy of 99.9 per cent. The reason why this degree of accuracy is important may be seen from a brief consideration of the

frequency assignments to broadcasting stations. The waves used by the broadcasting stations are spaced 10 kilocycles apart (3 meters at a wavelength of 300 meters). Thus one station is on 990 kilocycles, another on 1000, and another on 1,010 kilocycles. If one of these is inaccurately adjusted by as much as 0.1 per cent. this would mean a variation of 1 kilocycle from the established value. The next station having a frequency only 10 kilocycles different, this variation of 1 kilocycle is decidedly appreciable in comparison with the 10 kilocycle separation. A variation of the frequency of 1 per cent, for example, would be a variation of 10 kilocycles and could cause one station to be using exactly the wave that had been assigned to another. The whole success of American broadcasting is thus tied up with the placing of broadcasting stations on the correct frequencies to an accuracy approaching 99.9 per cent. Since receiving sets are now available by which an individual can hear the stations from all over the United States on the same night, the importance of this accuracy is apparent.

The basis of frequency measurement of the Bureau of Standards includes absolute frequency measurements by four entirely independent methods. These are:

A. Measurement or calculation of capacity

and inductance of carefully constructed standard condensers and inductors.

B. Measurement of frequency of the sound from a tuning fork, together with measurement of ratio of such frequency to radio frequencies by use of harmonics from an electron tube generator.

C. Measurement of frequency of the sound of a tuning fork, together with measurement of the ratio of such frequency to radio frequencies by the use of Lissajous figures produced by the direct application of the two frequencies to a cathode-ray oscillograph. This method is free from the assumption of integral ratios involved in the harmonic method (B).

D. Measurement of the actual length of very short waves and calculation of the frequency from this and the known velocity by the relation,  $f = v/\lambda$ . ( $\lambda$  = wavelength in meters). Ratios of frequencies thus measured, to lower radio frequencies, are obtained by the same general methods for ratio measurements as in B and C.

These four methods are not all that are theoretically possible. Another one that could be used is the accurate measurement of the speed of a radio-frequency alternator. Every method goes back ultimately to the measurement of a time interval.

Method A was the first method to be used by the Bureau of Standards. Where this system is employed, the capacity of specially designed condensers are measured by their charge and discharge at about 1 kilocycle. The inductance of the standard inductors is measured at the same frequency. The design of both capacity and inductance standards is such that there is no appreciable change with frequency. The capacity of coil and leads is measured by the use of harmonics as described on page 100 of the Bureau of Standards Circular 74, entitled "Radio Instruments and Measurements." This standard wavemeter, with its instruments for indicating resonance, is shown in Fig. 1.<sup>1</sup>

Method B employs the frequency of a tuning fork as the starting point, measuring the ratio of such frequency to radio frequencies by means of harmonics of the current in an electron tube generator. The use of harmonics for establish-

<sup>1</sup>Further information on the standard wavemeter is given in an article now in preparation entitled, "The Standards of Radio Frequency of the Bureau of Standards," by Mr. E. L. Hall, who is in charge of radio standards and testing. The time and place of publication of that article, and others referred to below, will be announced in the Radio Service Bulletin.

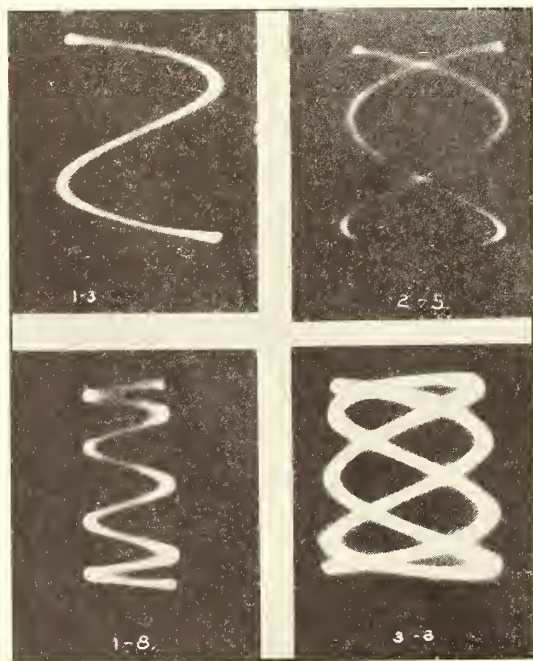

FIG. 2

Lissajous figures giving accurate frequency ratios



ing radio frequency ratios has been described in Circular 74, page 103. The method has been especially developed by Prof. H. Abraham whose apparatus is known as the multivibrator. The multivibrator has not been set up in the Bureau of Standards laboratory, but has been in use in the Naval Radio Research Laboratory located at the Bureau of Standards. Comparisons of this multivibrator and the other methods have been carefully made throughout the range from 18 to 3600 kilocycles.

In method C, the frequency of a tuning fork is carefully measured with a chronograph, and ratios of this to frequencies in the radio range are measured by the use of the cathode-ray oscillograph. This device is a special kind of vacuum tube in which a beam of cathode rays produces a spot of light on a fluorescent screen placed in the end of the tube. When the beam is deflected the spot moves across the fluorescent screen. Provision is made for deflecting the beam in two directions at right angles to each other by two pairs of small condenser plates to which controlled voltages may be applied. When two alternating voltages are applied which have frequencies related by a simple ratio, the spot of light traces out a Lissajous figure on the fluorescent screen. The shape of the Lissajous figure tells the ratio; the examples in Fig. 2 show this. The two pairs of deflecting plates are connected in parallel with the condensers of two independent generators of currents of audio or radio frequency. In the first step of the standardization process, the "low-frequency" generator, Fig. 3, is an electron tube generator of approximately 1 kilocycle, the frequency of which is determined by the tuning fork. The "high-frequency" generator is an electron-tube generator having a frequency anywhere from  $1\frac{1}{2}$  to 22 times this, the frequency being varied until successive Lissajous figures appear on the screen. The frequency ratio thus measured is extremely accurate, being in all cases closer than the accuracy of setting of the standard wavemeter, which is tuned to the frequency of the "high-frequency" generator. The method was largely developed by Mr. R. T. Cox. Its use will be described in a separate publication entitled, "Primary Radio Frequency Standardization by Use of the Cathode-Ray Oscillograph," by Misses F. Kenyon and G. Hazen.

In method D, a direct measurement of the wavelength of short waves on wires is made by coupling a short-wave generating set (Fig. 4) to

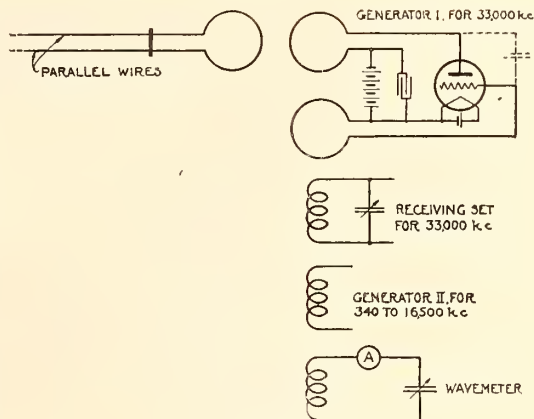

FIG. 3

Showing connections of generators whose frequencies are compared by the cathode-ray oscillograph

a loop of wire connected to one end of two long parallel wires approximately 4 centimeters apart. A short wire at right angles to the parallel wires, and containing a thermo-element is moved along the parallel wires and the positions of successive maxima of current are noted. The distances between these positions are each a half wavelength. They are measured with a steel tape, and agree within a few hundredths of one per cent, for the wavelengths used, 9 and 16 meters. These wavelengths correspond to frequencies of approximately 33,000 and 19,000 kilocycles respectively. These frequencies are not so high as to be beyond practical application in radio telegraphy and telephony. Experiments at the Bureau have shown how to produce them and to use them for communication as well as for measurements.

The method of harmonics has been used to step down from the very high frequencies thus produced and measured to radio frequencies in the whole range down to 340 kilocycles. This is done by placing between generators I and II (Fig. 5) a receiving set tuned to the frequency of generator I which produces the current in the parallel wires. Generator II is an auxiliary, the frequency of which is varied until one of its harmonics approaches the frequency of generator I. The frequency of Generator II is adjusted until the beat note heard in the receiving set becomes zero. The wavemeter is meanwhile tuned to the frequency of the generator II. The frequency for that setting of the wavemeter is then the frequency obtained from the wavelength measured on the parallel wires, divided by the number of the

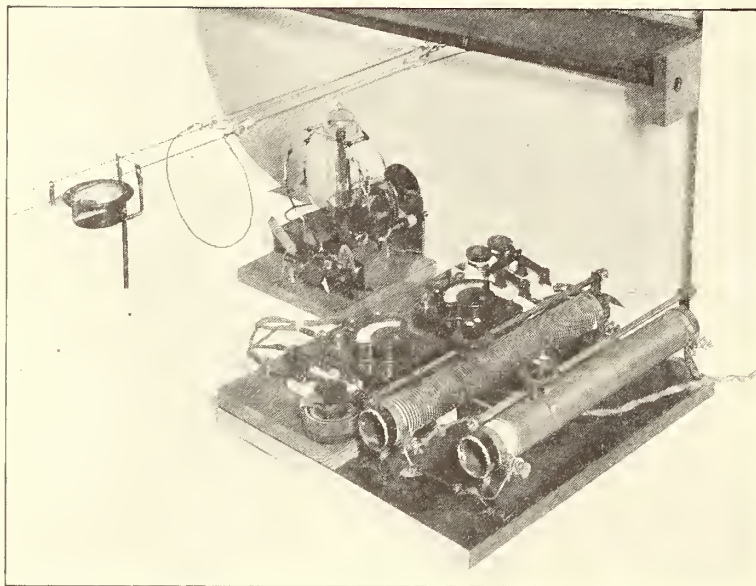

FIG. 4

Generator, detecting instrument, and end of parallel wires used to measure very high frequencies

harmonic. The measurement of these very high frequencies and establishment of the frequency basis by this method is described in a paper prepared by Messrs. F. W. Dunmore and F. H. Engel entitled, "A Method of Measuring Very Short Wave Lengths and Their Use in Frequency Standardization."

The step down from the very high frequencies to some of the more commonly used radio frequencies can also be made by the cathode-ray oscillograph, as described above, obtaining a Lissajous figure directly between the very high frequency and a lower one from an auxiliary generator, the latter frequency being measured by the wavemeter. The method is difficult at such high frequencies, and the work is still in progress.

The results of the independent establishment of the frequency basis by methods A, B, C, and D have been intercompared and the order of agreement is 0.1 per cent. to 0.2 per cent. When the present series of measurements is completed, the Bureau of Standards frequency basis will be certainly accurate well within 0.1 per cent. This frequency basis extends from 3.5 to 33,000 kilocycles.

While an accuracy of 0.1 per cent. is all that has been sought, for present needs, this will clearly not be adequate for the future. It is highly desirable for some purposes to place a heterodyne receiving set on a definite pre-

determined frequency with great accuracy. It would be possible to recognize transmitting stations by the beat note produced in such a heterodyne receiving set. This is important for certain Navy requirements. In order that the beat note may not vary from the pre-determined value by more than, say 100 per second, this means that the station which it is desired to receive should have its frequency adjusted accurately to  $\frac{1}{100}$  of a kilocycle which is 0.01 per cent. for a frequency of 1,000 kilocycles. It will be quite possible in the next year or two to attain this accuracy (0.01 per cent.) through further series of careful measurements and particularly by improvements in

the frequency standards and methods of indicating resonance.

The frequency standards have in past years been made available to the country only through the standardization of wavemeters at the Bureau of Standards. This service is now extended through the transmission of standard frequency signals and through measurements at the Bureau of the frequency of various transmitting stations. Only a small amount of direct wavemeter standardization can be done by the Bureau. Because of the Bureau's limited personnel, it has been necessary to restrict tests of wavemeters and other apparatus solely to important standards. The transmission of signals of standard frequency, however, which was begun in March of this year, places the frequency standards in the hands of all who care to use them. These signals are sent out approximately monthly, with special repetitions weekly during May and June, 1923. Starting at 11 P. M., so as not to disturb broadcast programs, some eight or ten standard frequencies are transmitted, the intervals between transmissions on the particular frequencies being approximately 15 minutes. Announcements are given both in radio telephony and in continuous-wave telegraphy, and the standard frequency is transmitted as a series of long dashes and the letters WWV. Methods by which these waves can be received



and wavemeters standardized are very simple. Information on this matter is given in Bureau of Standards Letter Circular No. 92, a limited supply of which is available at the Bureau of Standards, Washington, D. C. The standard frequency signals are transmitted with an electron tube set rated at 1 KW, having a radiation of approximately 150 meter-amperes. The schedules of transmission are announced in the newspapers and in the Radio Service Bulletin. The transmission and utilization of the standard frequency signals are further described by an article in preparation by Mr. H. J. Walls, entitled, "Radio Signals of Standard Frequency."

These signals are received and used throughout the United States east of the Mississippi River. No permanent means have as yet been provided for extending this range to cover the western part of the United States. One method that may be used is the transmission of signals, the frequency of which is kept constant for a certain number of minutes, by a Mid-Western broadcasting station. Measurements of this transmission can then be made by any one, using the same methods as are used for receiving the Bureau of Standards signals of standard frequency. The measurements will simultaneously be made by the Bureau of Standards and the values so measured will be announced by the Bureau.

A final method of supplying frequency standards uses the ether itself as a wavemeter. The transmitting stations operating on definite frequencies are the points on this wavemeter. Broadcasting and other stations will more and more from now on utilize a radio frequency indicator to assure operation on the assigned frequency every time they transmit. Measurements of the actual transmitted frequencies of various stations are made from time to time at the Bureau of Standards. When these measurements for a given station show great

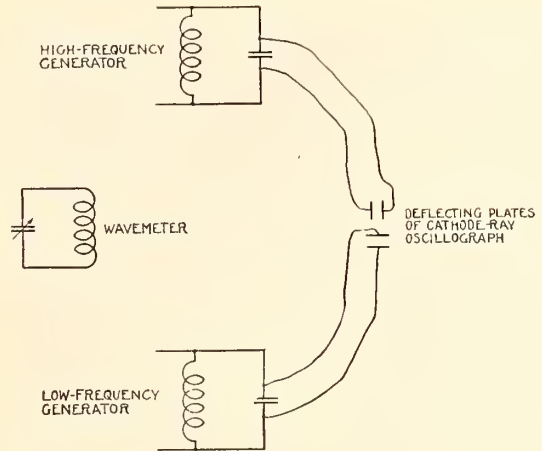

FIG. 5

Arrangement of apparatus for stepping down from very high frequencies

constancy, and the station is known to use a suitable frequency indicator, so that the Bureau is convinced that the station's operating wave can be used as a frequency standard, the Bureau will so announce. These announcements will probably be made in the Radio Service Bulletin. The transmissions from such stations can then be used as known points on the ether wavemeter.

Summarizing, means have been provided whereby accurate frequency adjustment of radio stations is possible. Great improvements have been made in the primary frequency standards and in their availability to the public. This will of itself remove a large portion of existing radio interference and make it possible to realize the benefits of the new frequency allocations recommended by the Second National Radio Conference. It seems quite certain that before long the ether itself will be a standard wavemeter with the frequencies of a number of the transmitting stations as its fixed points.

## Next Month! The Ultimate Receiver

Mr. Walter Van B. Roberts, whose articles "A Single-Tube Loop Set in a Brief Case" and "Operating a Loud Speaker on One Tube, Without Batteries" appeared in our May and June issues, respectively, is preparing another article—just as interesting and even more important—for our August number. In building the particular kind of super-heterodyne receiver which he is going to describe, Mr. Roberts has incorporated suggestions from the best technicians of to-day. Although having but two wavelength controls, this receiver is to combine the best there is in the super-heterodyne, the neutrodyne and inverse-duplex methods. With a laboratory model, Mr. Roberts is hearing KFI and KHJ (from Princeton, N. J.) on a loop and five tubes. We know of no receiver that exists which will compare in selectivity, long range and ease of operation with the one which Mr. Roberts will describe in RADIO BROADCAST for August.—THE EDITOR.



## Recent Broadcasters in New York Studios



**S. L. ROTHAPPEL FILLING THE AIR WITH FUN**  
He receives, on an average, 1500 letters a week from listeners-in who enjoy his witty announcements between selections broadcasted from WEAF via the Capitol Theatre, of which he is the Director



© Underwood & Underwood  
**FRIEDA HEMPEL SINGS "HOME SWEET HOME"**  
As part of the celebration of the 100th anniversary of John Howard Payne, creator of the best-known song in the world. In the picture Miss Hempel is shown at WJZ's Waldorf Astoria studio



**THREE RADIO CORPORATION PRINCIPALS AT THE OPENING OF RADIO BROADCAST CENTRAL**  
Left to right: Mr. Owen D. Young, Chairman of the Board of Directors; Dr. Alfred N. Goldsmith, Director of Research, and Major-General James G. Harbord, President of the Radio Corporation of America. Their speeches marked the opening of the Aeolian Hall stations, WJZ and WJY, on May 14th



# Dry Cells and UV-199's

By E. E. HORINE

National Carbon Company, Inc.

THE UV-199 vacuum tube is the latest and smallest member of the Radiotron family. The men responsible for its development, realizing the handicaps of the storage battery for radio receiving, have made it a dry cell tube. And while the voltage required to operate this tube is higher than for other dry-cell tubes, it is so sparing of current that under certain circumstances it is entirely feasible to operate it from an A battery made up of flashlight cells!

This remarkable decrease in filament energy, compared with storage battery tubes, has not been accomplished at a sacrifice of other desirable features. As a matter of fact, the electron emission from the tiny UV-199 filament is greater than from the husky filament used in the UV-201, which requires 1 ampere at 5 volts for normal operation. This gives the UV-199 somewhat better characteristics as an amplifier, because with greater electron emission, larger B battery energy is made available for the operation of the telephone receivers.

Prior to the introduction of the UV-199, about the only dry-cell vacuum tube available to the public was the WD-11. This was really the first tube put out which gave successful results on dry cells. The phenomenal popularity of the WD-11 is due to its ability to use dry cells, with advantages of low cost, reliability,

freedom from attention, and ease of renewal. It is not surprising, therefore, that the WD-11 should prove to be the forerunner of the dry-cell class of tubes.

The filament of the UV-199 differs somewhat from that of the WD-11 in its electrical characteristics, in that the UV-199 is what we might

call a high-voltage, low-current tube, while the WD-11 is a low-voltage, high-current tube. Although both tubes were designed to utilize the energy of dry cells, this outstanding difference in filament characteristics makes it necessary to employ different battery connections for the two tubes.

The current required by the UV-199 tube is .060 ampere (60 milliamperes). The voltage necessary to force this current through the filament is 3.0 volts, and in order to get this voltage, three dry cells connected in series must be employed. Herein lies what to some is considered a discrepancy. It is generally known that the voltage of an unused dry cell is 1.5 volts. Actually, it is usually

in excess of this figure, sometimes running as high as 1.6 volts in new cells, but for convenience, and to employ round numbers, it is usually stated as being 1.5 volts. Since the UV-199 requires only 3.0 volts, the question naturally arises, "Why is it necessary to use three dry cells? Why not two?"

It must be remembered that one of the char-

## Do You Know

Why it is more economical to use three dry cells rather than two, to operate a UV-199 tube, although the rated filament voltage of the tube is 3, and three dry cells in series deliver  $4\frac{1}{2}$  volts?

Why it is more economical to use three dry cells than four, even though four permit each cell to be used for a longer period?

Why, with 199's, it is best to use large B batteries, except for portable sets, in which lightness comes first in importance and operating cost comes second?

What the "cut off" voltage of dry cells is, and how it governs your operating expense?

Why it is more economical to use large dry cells than those of the flashlight variety for your A battery, although the voltage rating of each is the same?

Why, when operating one, two, or three 199's from three cells, you should use a 30-, 20-, or 10-ohm rheostat respectively?

These facts and others are thoroughly and interestingly described in this article. In presenting this work of Mr. Horine's to you, RADIO BROADCAST believes it is performing a valuable service. This is the type of article you will want to read at once, to be thoroughly posted on the UV-199 tube; and you will do well to keep it handy for future reference.—  
THE EDITOR.

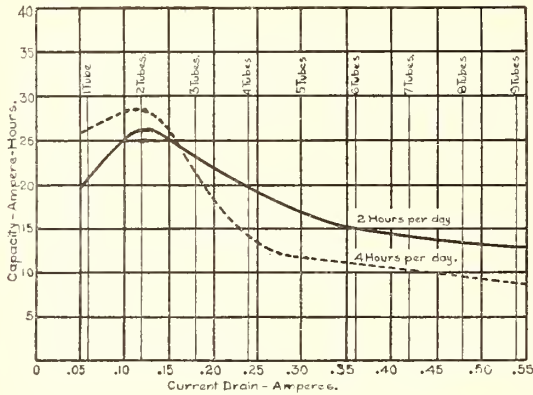

FIG. 1

Illustrating how different current drains affect the capacity of a dry cell

acteristics of dry cells is that the voltage drops slightly when current is drawn from them. The nominal figure of 1.5 volts per cell is what is known as the "open circuit voltage"; that is, the voltage of the cell when delivering no current. As soon as the cell is connected to any device which draws current from it, a different voltage, called the "closed circuit voltage" is obtained. The closed circuit voltage of a dry cell is always less than the open circuit voltage.

Obviously, it is the closed circuit voltage of the cell that we are primarily interested in. And while a battery made up of two dry cells connected in series will have an open circuit voltage of 3 volts, the minute such a battery begins delivering current to one or more UV-199 tubes the voltage will drop to something under 3 volts, which is less than that required by the tube for satisfactory operation.

Another important reason for using a battery of three cells connected in series for UV-199 tubes lies in the matter of service obtainable from the cells. As more and more energy is drained day after day from them, the voltage gradually drops, until eventually the available closed circuit voltage is just equal to that required by the tube. Any further withdrawal of energy will reduce the cell voltage to a point lower than that required by the tube, and unsatisfactory operation will result. It is evident that the lower this permissible minimum voltage (called the "cut-off voltage"), the more energy may be obtained from the cells. The cut-off voltage is determined by the electrical characteristics of the filament, which, in the case of the UV-199, is 3.0 volts.

Therefore, when three cells are used, the range through which they can be worked is the

difference between the initial 4.5 volts and the final 3.0 volts, which is 1.5 volts for the battery, or .5 volt per cell. On light current drains, a cut-off of 1.0 volt per cell is sufficiently low to insure obtaining a major portion of the total energy originally stored in the cell, whereas, if the cut-off is made 1.5 volts, which would be the case if only two cells were used, the amount of service obtainable would be very small, indeed.

On account of the extremely small current taken by the UV-199 tube, filament rheostats having much more resistance than common must be employed. If the voltage of a new dry-cell battery is 4.5 volts, the rheostat must be able to absorb 1.5 volts with a current of only 60 milliamperes flowing through it. This immediately establishes the minimum resistance necessary at 25 ohms, but in order to provide a reasonable factor of safety, and to allow for flexibility in making adjustments, a rheostat having at least 30 ohms should be used.

The greatest amount of service from the battery will be obtained by always adjusting the filament rheostat as close to the "off" position as possible, consistent with good performance. Incidentally, this method of control will also result in prolonging the life of the tube.

When so used, the filament rheostat can be looked on as a rough indicator of the condition of the battery. With new cells, it will be necessary to move the rheostat only a very short distance away from the "off" position. As the voltage of the cells is reduced through service, the handle must be moved farther and farther over to obtain good results, until finally, it must be thrown all the way over. This is an indication that the voltage of the dry cells has fallen to the voltage of the tube, and when this happens, the cells are exhausted and should be discarded and new ones installed.

The capacity of a dry cell is measured in ampere-hours, the same as a storage battery. An ampere-hour is the amount of electricity taken from a battery when a current of one ampere flows for one hour, or  $\frac{1}{4}$  ampere for four hours, or  $\frac{1}{8}$  ampere for eight hours, etc. It is always obtained by multiplying the time in hours by the current in amperes.

It is impossible to state the capacity of a dry cell, unless all the conditions under which the cell will work are known. The question, "What is the capacity of a dry cell?" is quite similar to that old one, "How high is up?" It is as easy to answer one as the other.



There are three major factors, each having an important bearing on the capacity of a dry cell, and all three are under the control of the user. They are: the cut-off voltage, the current drain, and the average number of hours the cells are used daily.

Just how can the user control these factors? Take the cut-off voltage. This, in connection with the UV-199 tube, is determined by the number of cells, connected in series, used to operate the tube. For example, the tube voltage is 3.0 volts. If two cells are used, the cut-off for the two cells is 3.0 volts, or 1.5 volts per cell. With three cells, the cut-off becomes 1.0 volt per cell, and with four cells it is  $\frac{3}{4}$  of a volt per cell. In general, the lower the cut-off voltage, the greater the capacity of the cell, but in this case, it is inadvisable to reduce the cut-off of  $\frac{3}{4}$  of a volt by using four cells, for two reasons. First, the cost of a fourth cell is a  $33\frac{1}{3}$  per cent. increase over the cost of three cells, while the extra amount of service obtained by using four cells is less than  $33\frac{1}{3}$  per cent. greater than from three cells. In other words, it is not economical. Secondly, there are no filament rheostats generally available having sufficient resistance to absorb the extra voltage of the additional cell. As far as the UV-199 tube is concerned, therefore, the cut-off becomes established at 1.0 volt per cell.

The effect of different current drains on the capacity of a dry cell is somewhat involved. In general, the smaller the current, the greater the capacity, but this is true only within certain limits. If the current taken from the cell is too small, the time required to exhaust it is so great that the factor of natural depreciation becomes active, thereby reducing the capacity. If the current is too great, the capacity is again reduced, due to the lowered battery voltage. So, in choosing a current drain for dry cells, one must be taken which is somewhere between these two extremes. It is necessary to choose between a heavy current, which discharges the cell rapidly, but reduces its capacity, and a very light drain which prolongs the time of service, but also reduces the capacity. On radio loads, where current is drawn from the cells for an average of two or more hours per day, this happy medium occurs somewhere in the neighborhood of  $\frac{1}{8}$  ampere.

The two curves shown herewith (Fig. 1) serve to illustrate how different current drains affect the capacity of a dry cell. The solid curve shows the capacity of dry cells when delivering

current two hours per day, and the dotted curve the capacity when the cells were operated four hours per day. Both curves represent the capacity of a dry cell to a cut-off of 1.0 volt, and are the average results obtained by testing a large number of different makes of cells. It is not intended that the figures given on this chart, or in the discussion of it, be taken literally as an absolute measure of the capacity of a dry cell. They are merely intended to give an approximate idea of what the average user may expect from the usual general-purpose dry cells when used to operate UV-199 tubes. Some operators will obtain greater capacity than indicated, and others will obtain less, depending on their skill and the conditions of operation.

It will be seen that in both cases, maximum capacity is obtained at a current drain of about one-eighth (.125) ampere. At smaller drains than this, the capacity falls off, due to the natural depreciation of the cell, and, as is to be expected, the decrease in capacity is greater for the cells which were in use only two hours per day, because the length of time required to exhaust them was so much greater. Thus, at a current drain of .06 ampere (the current taken by one UV-199 tube) the capacity at 2 hours per day was 21 ampere-hours, which means that the number of hours service obtained was 350. Since the cells were discharged only two hours per day, it required 175 days, or approximately six months to complete the test. In the case of the 4 hour per day cells, the capacity was 26.4 ampere-hours, which was 440 hours of service. But since these cells were in use 4 hours per day, the test only lasted 110 days, or about  $3\frac{2}{3}$  months instead of six, and it is this shorter time which explains the increase in capacity.

Although it is in the power of the user of a

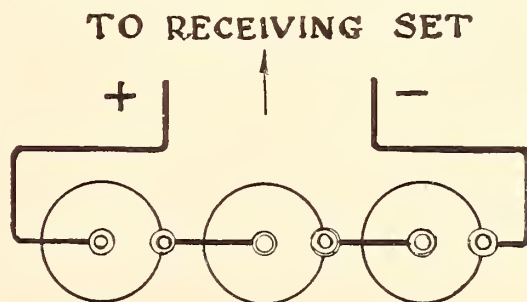

FIG. 2

Three dry cells connected in series. This is the most economical A battery for sets employing from one to three UV-199 tubes

radio set to regulate the number of hours of service each day, it is unreasonable to expect him to do it. Under certain conditions, greater capacity will be obtained from dry cells by reducing the number of hours they are in use daily, but can you imagine a radio enthusiast shutting down his set at 8:57 p. m., right in the middle of a good program, merely because by so doing he will be adding a possible 5 per cent. or 10 per cent. to the life of his A battery? It is to laugh.

The number of hours the average set is used daily is a moot question. At one time, it was generally felt that two hours a day was fairly representative of average performance. But of late, loud speakers are coming into more general use, and because of this, the amount of time put in by the average set has gone up considerably. Eventually, of course, all receiving sets will employ loud speakers. A receiving set without a loud speaker will some day be as much of a curiosity and excite as much comment as an automobile without a top. Because of the tendency toward universal loud-speaker operation, it is felt that the time the average set is used daily is closer to four hours than two. There are some individual cases known where the set is used an average of eight hours a day!

The most economical current drain on the dry cells used as an A battery can be obtained by connecting the proper number of cells in multiple. When this is done, the total drain is equally divided between the cells, so that each one delivers only a fraction of the total. In

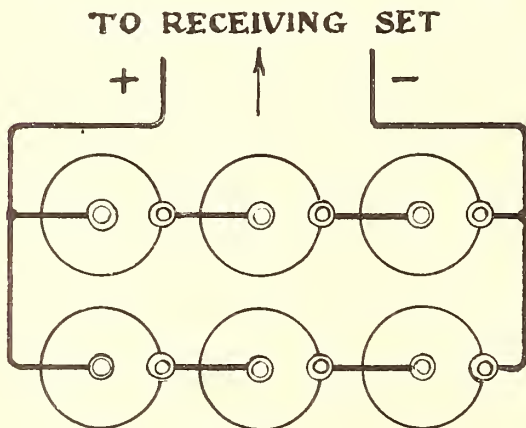

FIG. 3

From sets employing four or five tubes, maximum economy will be obtained by using six dry cells, connected three in series and two in multiple, as shown here. When flashlight cells are used, this last arrangement forms the most economical A battery for one tube

connection with UV-199's, however, the situation is somewhat complicated, because of the necessity of using three cells connected in series to obtain the correct voltage. This is not so bad as it appears, for it is only necessary to consider three cells connected in series as a battery. Then any number of such three-cell batteries may be connected in multiple to get the most economical drain on each.

The curves (Fig. 1) will be useful in determining the most economical battery for any given radio set. As an example, assume a set having three UV-199 tubes. The total drain therefore is  $3 \times .060 = .180$  amperes. Reference to Fig. 1 shows that the corresponding capacity is 23 ampere-hours when used two hours per day. If the drain is reduced by using two three-cell batteries connected in multiple, the total drain of .180 amperes is equally divided between the two batteries, so that the drain on each is only .090 amperes. But at this drain, the capacity of each battery is only 22 ampere-hours, which is less than when the drain is .180 amperes. Therefore, for sets employing one to three UV-199 tubes, the most economical "A" battery is one made up of three six-inch dry cells, connected in series (Fig. 2).

Now, take the case of a four-tube set. Here the total drain is .240 amperes, and the corresponding capacity is 19 ampere-hours. By using two three-cell batteries connected in multiple the drain on each is reduced to .120 amperes, with a corresponding capacity of 26 ampere-hours for each battery, or a combined capacity of 52 ampere-hours. This is by far the most economical battery to use, for while it requires double the number of cells, the amount of service is considerably more than doubled.

Applying the same method of calculation to different numbers of UV-199 tubes, the most economical battery is found to be as follows:

For one to three tubes, use three cells connected in series (Fig. 2).

For four or five tubes, use two three-cell batteries connected in multiple (Fig. 3).

For six or more tubes, use three three-cell batteries connected in multiple (Fig. 4).

Because of its ability to operate from an A battery made up of flashlight cells, the UV-199 lends itself admirably to the construction of small portable sets. Such a battery is much smaller and lighter than a six-inch dry cell, and, taking advantage of these properties, it is possible to design a complete receiving set,



including all the necessary batteries in a remarkably small amount of space. It should be remembered, however, that electrical energy in the form of flashlight cells is somewhat more expensive than in six-inch dry cells. Therefore, when designing a portable set, it is advisable to provide terminals to which an external A battery of six-inch dry cells may be connected. Then, when the set is to be used at home, use the large battery, and depend on flashlight batteries only when the set is to be taken away on a trip.

Only the largest size flashlight cells, which are approximately  $2\frac{1}{4}$  in. long and  $1\frac{1}{4}$  in. in diameter, should be used. They take up very little more room than the smaller sizes, but they last a great deal longer.

The current drain which gives maximum capacity for the large size flashlight cell is .030 ampere. This is one half the drain caused by one UV-199 tube, therefore, the most economical flashlight A battery is one using six cells for each tube, connected as in Fig. 3. However, a single three-cell battery will give remarkable results, considering its size. When used between one and two hours per day, such a battery of reliable manufacture will give approximately 30 hours of service, which is sufficient for most vacation trips.

Never attempt to operate more than one UV-199 tube from a battery of three flashlight cells. Use at least as many such batteries as there are tubes in the set, otherwise the current drain on the cells will be so heavy that the amount of service obtainable from them will be seriously reduced.

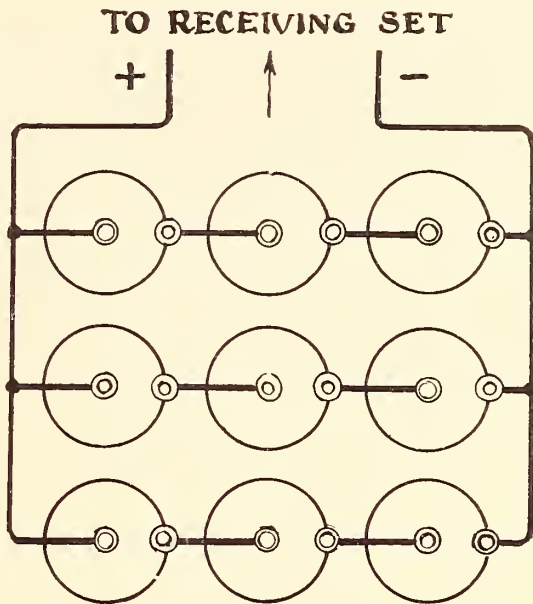

FIG. 4

When six or more UV-199's are used, it is best to employ nine dry cells connected as shown above

In planning the construction of a small portable set, the designer will naturally utilize the smallest size B battery, to conserve space and cut down weight. But for home use, it is inadvisable to depend on these tiny batteries, primarily because their capacity is extremely limited. Provision should be made for connecting a large external B battery to the set, just as in the case of the A battery. The large size B battery has many times the capacity of the small one, but costs less than twice as much.

## What Radio Holds for Boy Scouts

A Brief Outline of Some of the More Important Possibilities of Radio in Their Application to One of the Biggest and Best Games America has Ever Gone in For

By ARTHUR H. LYNCH

**A**S MOST of us know, the Boy Scout is pledged to "Do a good turn daily." Let us consider briefly some of the aspects of radio as they may be applied to Scouting to make it possible for a number of good turns to be done. One of the best troop activities I know of is the building of complete receiving sets by troops for installation in hospitals. Scout

leaders throughout the country should appreciate some of the direct benefits which will come to their troop following a campaign of this sort. First of all, it will indicate quite clearly to the citizens of the community that the particular Scout troop engaged in this work is not only interested in its own welfare but in the welfare of the community. And what better activity could any of us engage in than

doing our small part to make life more pleasant for those in hospitals?

In order to put a radio set in a hospital satisfactorily, it is generally necessary to arrange for two types of reception. As a rule a complete receiving set provided with suitable amplifiers is all that is necessary. If this outfit is of the loop variety, it may be mounted on a "tea-wagon" and wheeled about from one room to another without difficulty. If it is taken into a convalescent ward it is unlikely that a loud speaker would prove disturbing to any of the patients, but in those rooms or wards where the patients are very sick, a better arrangement is to have a telephone receiver or pair of receivers attached to a plug and placed beside each bed. In this instance, the tuning equipment would be controlled by a hospital attendant and the incoming signals would be sent through the hospital on a set of wires with plugs at each bed. Patients who desired to listen-in would then only have to place the plug attached to their telephones in the socket

to hear whatever was going on, without annoying their neighbors in any way.

In a community of any size it should not be difficult for an active Scout troop to secure an appropriation large enough to pay for the wiring if the troop itself would undertake to furnish the radio equipment, and it is likely that those who enjoy this broadcasting brought to them by the Scout troop will look with favor upon other activities that this particular troop undertakes.

#### IN THE CONTAGIOUS SICK ROOM

ANOTHER very important work that lends itself particularly to Scouting is the installation of receiving outfits in the homes of people who are quarantined because of contagious diseases. Scarlet fever, for example, is sometimes followed by serious complications, and in order to ward off complications of this nature it may be necessary for the patient to be kept in a dark, or partly dark, room. In order that the eyes may not be strained, reading



CONVALESCING HOSPITAL PATIENTS FIND RADIO A GREAT BOON

It helps to pass pleasantly the time they must lie in bed or stay indoors. A whole troop of scouts should have little difficulty in earning enough to pay for the installation and up-keep of a set such as this in the hospital in their community



is not allowed and where a contagious disease exists, the patient is not even allowed the privilege of an occasional visit from his friends. Naturally, a person who is ordinarily active and in touch with the affairs in the world, when confined to bed under conditions of this sort finds the rest particularly irksome. A radio set, in such a case, will undoubtedly win for the Scout or Scout troop that installs it the everlasting appreciation of the patient.

In making an installation of this character, however, every precaution should be taken to safeguard oneself against the possible contraction of the disease, and it is not advisable for those who supply the equipment to make the installation personally because it would be possible to carry the disease to others even though they did not contract it themselves. It is always better to make an installation of this character in strict accordance with the dictates of the local Board of Health. For example, a set might best be assembled out of the sick room, and its operation explained to someone in charge of the patient.

#### IN VETERANS' HOSPITALS

**M**OST of us hear very little to-day of those war veterans who are patients in hospitals maintained by the Government, but there are a great many of them. Would it not be well for the Scouts of the country to undertake a campaign to secure radio outfits for these men? In many instances some of those in the hospitals are quite familiar with radio receiving equipment and would be able to install and operate outfits if they had them. In this way they would be able to bring entertainment to the fellows who are still confined to their cots.

*A great many radio sets have been bought that are not at present being used.* Many people who purchased crystal outfits have gradually put them aside in favor of tube sets. These crystal outfits are performing the rather useless function of collecting dust in attics or closets. The number of broadcasting stations in the country has increased so rapidly that very few veterans' hospitals are now out of range of all stations, with a crystal receiver. Receiving



SCOUTS LEARN TO MAKE THINGS WITH THEIR HANDS

An up-and-doing crowd of boys such as this could do a good turn, size extra large, by combining to build radio receivers for invalids

outfits would be particularly appreciated at this time of year when most of the stations in the country are broadcasting the baseball scores. Most of these men are baseball fans and follow the game as closely as they can. One of the best ways to help put some fun and diversion into the lives of these fellows is to get them to think about baseball. A radio set will help them to do it.

#### IN SCOUT CAMPS

**T**HERE are many Scout camps in this country at present, and it is more than likely that the majority of these camps will have at least one good radio outfit this summer. The large set may be used in the evening to entertain the gang and the various small sets may be used in field communication activities. Simple low-powered telephone and telegraph transmitters will make the signaling course particularly attractive this summer. A good transmitting station at camp headquarters will serve to transmit all kinds of messages to troops in the field, and maneuvers may be engaged in that would be entirely impossible otherwise. Radio as a means of signaling is very much superior to wigwagging or even wire telegraphy; and another—and perhaps the best—application of radio in camp is a course in the building of receiving equipment under the guidance of a Scoutmaster who is thoroughly capable of carrying on this work. For instance, it is well for a camp to offer as part of its curriculum, a course in simple receiver design. The experience the boys get in building their own receivers is not only helpful to them in securing a knowledge of radio but it gives them an intimate knowledge of wood-

working, soldering and the use of various tools.

That the boys of this country are interested in this sort of work is very apparent from the fact that in a single camp last year seventy-six per cent. of the boys who attended constructed

radio receiving sets—and the fun didn't end with the boys: it gave them something with which to entertain the whole family.

Radio really has something to offer Scouting. Let all Scouts make the best of it this summer.

## Radio Broadcast Central

The Radio Corporation's Station at Aeolian Hall, New York — The Dream of the Pioneer of 1903, the Vision of the Engineer of 1913, a Reality for the Betterment of Mankind in 1923

By PIERRE BOUCHERON

Director of Advertising and Publicity of the Radio Corporation of America

**A**MID the hustle and bustle of the world's greatest metropolis, a new broadcasting station has been established. It is different from any station we have seen, so far, in that it is made up of a quadruple personality, so to speak. Except for the fact that it employs but two antennas, it incorporates four complete broadcasting stations. There are,

to be sure, only two studios, but in these days of out-of-the-studio broadcasting, two are quite sufficient, and the arrangements for this sort of broadcasting made at Radio Broadcast Central are in keeping with the great advance marked by the station itself.

For instance, a permanent group of wire lines has been run along Sixth Avenue for several miles, beginning at 14th Street. There are permanent lines from this central cable to the Town Hall, the Waldorf Astoria Hotel and Aeolian Hall. By running short, temporary lines to theatres or other important gathering places, it is possible to supply the radio audience with the best of music, drama, humor, lectures, religious services, and the like that New York can furnish. In opening Radio Broadcast Central, Mr. Owen D. Young, Chairman of the Board of the Radio Corporation of America, summed up this phase of the enterprise in the following words:

"Broadcasting has appealed to the imagination as no other scientific development of the time. Its ultimate effect upon the educational, social, political, and religious life of our

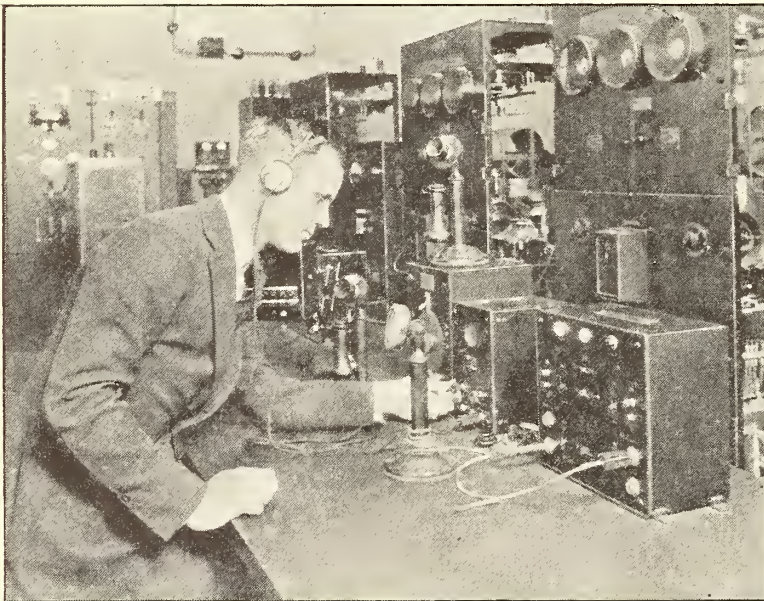

WHEN A TUBE "BLOWS"

It is necessary for the operator in the operating room on the roof merely to cut out the transmitter thus crippled and switch in another. There are two separate broadcasting "channels," one for WJZ and one for WJY, and each channel is equipped with two transmitters. Besides the operating crew, there is a man constantly listening-in for vessels in distress. If he hears an SOS, the broadcasting is immediately suspended



country and of the world is quite beyond our ability to prophesy.

"Already it is bringing to the farmer, market, weather, and crop reports as well as time signals, which cannot help but be of economic value: in remote communities, where the country parson is no longer in attendance at Sunday morning services, it is filling a great need in the spiritual life; its educational possibilities are being investigated by our foremost national and state educators; it is taking entertainment from large centres to individual homes; to the blind and sick it has unfolded a new and richer life. For the purpose of communication it has destroyed time and space."

There are two stations at Radio Broadcast Central, which may be operated simultaneously or individually. WJZ is the 455-meter station, used to broadcast music and entertainment of the lighter kind, while WJY, operated on 405 meters, is used for broadcasting opera, classical music, and lectures on more serious subjects.

At Aeolian Hall, where this super-station is located, WJZ and WJY are characterized as channels A and B respectively, and each is equipped with two complete sets of equipment in order to prevent any break in the program being broadcasted, regardless of any mechanical trouble that may develop. There are two pick-up devices in each studio, as well as a system of dual wiring from the studio to the control station on the roof where two complete transmitters are used on each channel.



AEOLIAN HALL, NEW YORK

From 40th Street, with the Public Library in the Foreground

The broadcasting from Aeolian Hall is already recognized as being of the highest character. In dedicating the station to the people of America, General Harbord, President of the Radio Corporation, said: "This station will gather from every part of New York City and from all available sources all that will instruct and entertain, and hurl it over millions of square miles of territory." It is, as the General expressed it, "the world's first national theatre."



# The Grid

## QUESTIONS AND ANSWERS

The Grid is a Question and Answer Department maintained especially for the radio amateurs. Full answers will be given wherever possible. In answering questions, those of a like nature will be grouped together and answered by one article. Every effort will be made to keep the answers simple and direct, yet fully self-explanatory. Questions should be addressed to Editor, "The Grid," RADIO BROADCAST, Garden City, N. Y.

### AUDIO AMPLIFYING CIRCUITS

*I have a two-step receiver of my own construction, using Cunningham detector and two Cunningham amplifiers.*

*This arrangement is not giving satisfaction, and I should appreciate your publishing what you consider to be the best amplifying hook-up.*

—E. E. B., Itta Bene, Miss.

AUDIO-FREQUENCY amplification has become so standardized that the various transformer coupled hook-ups have resolved themselves into a single-conventional circuit, which may be applied to any receiving set. This fact is at variance with the impression under which many of our readers labor, that different receiving circuits require different systems of audio-frequency amplification.

Figure 1 shows the usual circuit for a two-step amplifier. The three telephone jacks make it possible to plug in at the detector, first or second stage. The last jack (J<sub>2</sub>) may be an open-circuit jack, as in the diagram, or a closed-circuit one similar to J<sub>d</sub> and J<sub>1</sub>, the inner contacts running to binding posts for a loud-speaker. Thus, when the plug is removed (the headset eliminated) the loud-speaker is automatically thrown into the circuit.

No amplifier will operate properly on poor tubes or transformers, nor will satisfactory amplification be secured on a plate voltage under sixty. The bulb should be a hard one, i. e., there should be no blue or purple haze about the elements when the plate voltage is applied and the filament lighted. The amplifying transformers should be of a reliable manufacture, and the experimenter is advised to expend from four to seven dollars in procuring them, rather than purchase transformers of doubtful value for half that price.

The transformers should be mounted with at least four

inches between cores, and many experimenters make a practice of placing the transformers with the cores at right angles to each other. Careful separating of instruments and wiring in amplifying circuits eliminates feed-back with resulting howls and squeals.

Rheostats of the wire or compression types, vernier or otherwise, may be used. The 1½ volt tubes are also adaptable to amplification circuits, and will give very good results when used in conjunction with transformers designed to balance their impedance.

The only restrictions on panel layout are those concurrent with adequate spacing, and the experimenter may build the amplifier so that it will conform in appearance with his present apparatus. However, before constructing the set, it is suggested that the builder familiarize himself with the interior details of some standard manufactured amplifier.

Connections should be well soldered, using soldering paste rather than acid or rosin, and all superfluous flux should be wiped away, washing the joints if necessary with wood alcohol. This precaution is particularly important on the lugs of the jacks, where messy soldering will result in annoying clicks and extraneous sounds.

Such an amplifying installation (Fig. 1) may be added to any receiving set by disconnecting the telephone receivers, and replacing them by the primary of the first stage, amplifying transformer (input). Condenser C, indicated in the diagram, is a telephone shunt condenser of .002 mfd. capacity. It is possible that such a condenser is already included in the experimenter's present receiving equipment, in which case the extra capacity will not be necessary.

### MULTI-LAYER COILS AND INDUCTION

*Can you tell me what size honeycomb DL coils, according to catalogue numbers, are best for receiving broadcasts on 360*

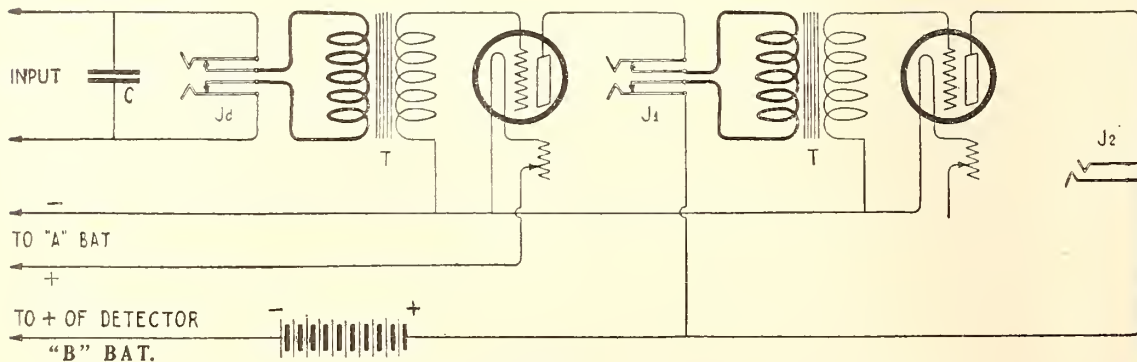
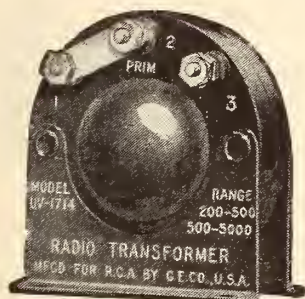

FIG. 1

The usual circuit for a two-step amplifier. The lead from the second amplifier rheostat should, of course, go to "+ A"



# Get Long Range with *RCA* radio- frequency transformers



Model UV-1714  
\$6.50

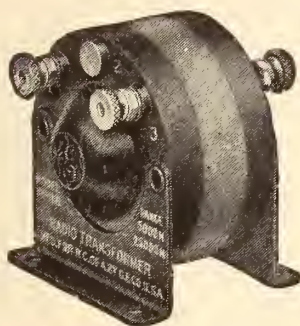

Model UV-1716  
\$8.50

—To make a small inside loop reach as far as an outside antenna.

—To increase tremendously the range of an outdoor aerial without distortion.

—To amplify singly or in cascade; complete shielding prevents interaction of fields.

—To cover a broad band of wave lengths and pick up stations of every class.

*Particularly Adapted for Use  
with RCA Radiotron Tubes*

Insist on RCA audio and radio-frequency transformers at your dealer



*This symbol of quality  
is your protection*

★  
**Radio**  **Corporation**  
*of America*

Sales Dept., Suite 2066  
233 Broadway  
New York, N. Y.

District Sales Offices  
10 South LaSalle Street, Chicago, Ill.  
433 California Street, San Francisco, Cal.

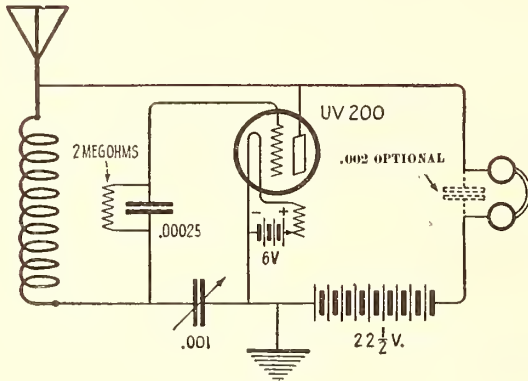

FIG. 2  
The "Flivver" Circuit

and 400 meters, i. e., the sizes to use in primary, secondary, and tickler? What do the numbers mean?

I would also like to know what causes the humming noise in my receivers when I am using two steps of audio-frequency amplification. It sounds like a generator hum, and it is present over the entire tuning range of the set.

L. T., CINCINNATI, OHIO.

THE DL35, DL50, and DL75 are the correct sizes for broadcast reception, primary, secondary, and tickler being respectively indicated.

On the original honeycomb coils, the numerals referred to the number of turns of wire wound on the designated coil. Thus, an L50 was wound with fifty turns of wire. However, a slightly different method of winding was shortly discovered, which resulted in coils superior to the original honeycombs; and it was found that the number of turns on the new coils, called the Duolateral or DL, necessary to secure a certain value of inductance, differed from the number of turns required by the honeycomb for the same effect. The numeral following the initials "DL" indicates that the duolateral coil may be substituted for a honeycomb coil of that number of turns.

The humming heard in the telephone receivers is probably due to induction from near-by electric light wires. A reading lamp on the operating table is often sufficient to give rise to such a disturbance, and usually the trouble can be remedied by merely moving the lamp farther from the instruments, particularly from the detector and amplifying cabinet. If ordinary care is taken to keep unnecessary electric light wires away from the apparatus, and to run those essential to its operation in armored cable, the hum will be eliminated.

However, if our correspondent is using a single-circuit tuner, it is possible that the sound is induced from the street lines to his antenna. If such is the case, an inductively coupled tuner will rectify matters.

#### FARM LIGHTING PLANTS AND RADIO

I am located on a farm which is equipped with a 32-volt lighting plant. Can this be used in any way for radio reception?

B. O. Z., BOUCK'S FALLS, N. Y.

A FARM lighting plant can be used very nicely for the lighting of receiving filaments, it being only necessary to include sufficient resistance in the circuit to drop the voltage and protect the tubes.

A series of 6- or 10-ohm porcelain-base rheostats is a convenient resistance for this purpose. Using a single tube drawing one ampere, such as the UV-200 and UV-201, a variable resistance with a maximum of 30 ohms will be sufficient to drop the 32 volts to the working potential of the bulb. However, if the WD-11, 201-A or a similar quarter-ampere tube is used, the resistance must be considerably higher, using not less than 125 ohms for a single bulb.

If two tubes are to be used constantly, the external resistance may be halved, and if three tubes, it may be lowered two thirds the total resistance given for a single tube. This is due to the fact that the voltage drop is directly proportional to the current consumed. Therefore, all tubes must be turned off by a common switch, and the circuit through amplifying filaments never broken until the resistance is increased to the required value for the remaining detector bulb.

In all cases where bulbs are lighted from a comparatively high voltage dropped through a common resistance, each tube should be separately fused, in order to protect the remaining bulbs when the filament of one burns out in the course of time. Unless this precaution is taken, the sound tubes will necessarily be blown in the sudden rise of the applied voltage.

In some types of farm lighting equipment one side of the line will be found grounded. While this will not affect reception with certain receivers, on the majority of circuits it will result in undesirable complications and probably decrease selectivity. When this ground is not effected through the frame of the engine and the exhaust pipe, it is easily eliminated by removing the ground wire.

#### THE "FLIVVER SET"

Will you please give me the circuit of the so-called "Flivver Set"? I am anxious to construct this apparatus which I understand is a very simple and excellent regenerative receiver.

The required parts are, I believe, 43-plate condenser (variable), 1 Duolateral coil of fifty turns, detector tube, etc.

R. W. W., WILKES BARRE, PA.

THE accompanying diagram (Fig. 2) indicates the connections for the "Flivver Set." The single tube "super" is also called the "flivver."

However, RADIO BROADCAST does not recommend the use of this circuit in its unmodified form in other than isolated radio districts. The flivver system, which oscillates almost continually during the process of tuning, is nothing more than the Colpitts transmitting circuit used extensively in continuous-wave transmission. Even when employed as a receiver, with a soft tube and low plate voltage, it is capable of radiating an interfering wave which may be often picked up with annoying consequences over a mile away. Out of consideration for other listeners this circuit, as shown, should never be used in cities or even small towns.

However, in such congested localities, the undesirable radiation may be eliminated by the addition of one step of tuned-plate radio-frequency amplification. There are several excellent sets, using this system, on the market. However, when this pound of cure is resorted to, the total expense of the apparatus, which is now a two-bulb set, and the complexity of the installation are such that the original purchase or building of a selective three-circuit tuner is recommended as preferable.





Any Good Receiving Set

Magnavox keeps the "stay-at-homes" happy

THE "boys" just naturally make their headquarters in proximity to the receiving set whose owner has been wise enough to add a Magnavox Reproducer and Power Amplifier. When "Magnavox invites you." the Radio party is sure to be a success.

Magnavox R2 Reproducer and 2 stage Power Amplifier (as illustrated) \$115.00

R2 Magnavox Reproducer with 18-inch horn: the utmost in amplifying power; requires only .6 of an ampere for the field . . . . . \$60.00

R3 Magnavox Reproducer with 14-inch curvex horn: ideal for homes, offices, etc. . . . . \$35.00

Model C Magnavox Power Amplifier insures getting the largest possible power input for your Magnavox Reproducer  
2 stage \$55.00  
3 stage 75.00

Magnavox Products can be had from good dealers everywhere. Write for new booklet.

**THE MAGNAVOX COMPANY**  
Oakland, California  
New York Office: 370 Seventh Avenue

# MAGNAVOX PRODUCTS

No Radio Receiving Set is complete without them



7-R

# Supplemental List of Broadcasting Stations in the United States

LICENSED FROM APRIL 21 TO MAY 17 INCLUSIVE

CALL SIGNAL	STATION	FREQUENCY (Kilocycles)	WAVE-LENGTH
KFEX	Augsburg Seminary, Minneapolis, Minn.	1150	261
KFGC	Louisiana State University, Baton Rouge, La.	1180	254
KFGJ	138th Inf., National Guards, St. Louis, Mo.	1130	266
KFGM	Abilene Daily Reporter, Abilene, Texas	1290	233
KFGP	Cheney Radio Co., Cheney, Kans.	1310	229
KFGQ	Crary Hardware Co., Boone, Iowa	1330	226
KFGV	Heidbreder Radio Supply Co., Utica, Nebr.	1340	224
KFGX	First Presbyterian Church, Orange, Tex.	1200	250
KFGY	Gjelhaug's Radio Shop, Baudette, Minn.	1340	224
KFGZ	Emmanuel Missionary College, Berrien Springs, Mich.	1120	268
KFFX	The McGraw Co., Omaha, Nebr.	1080	278
KFHC	University of Oklahoma, Norman, Okla.	1180	254
KFHD	Utz Electric Co., St. Joseph, Mo.	1330	226
KFHF	Central Christian Church, Shreveport, La.	1130	266
KFHI	Chas. V. Dixon, Wichita, Kans.	1340	224
KFHL	Penn College, Oskaloosa, Iowa	1320	227
KFIB	Franklin W. Jenkins, St. Louis, Mo.	1230	244
KFIC	Philip Laskowitz, Denver, Colo.	1340	224
KFID	Ross Arbuckle's Garage, Iola, Kans.	1220	246
KFIQ	Yakima Valley Radio Broadcasting Assn., Yakima, Wash.	1240	224
WABC	Fulwider-Grimes Battery Co., Anderson, Ind.	1310	229
WABD	Parker High School, Dayton, Ohio	1060	283
WABE	Y. M. C. A., Washington, D. C.	1060	283
WABF	Mt. Vernon Register-News Co., Mt. Vernon, Ill.	1280	234
WABG	Arnold Edwards Piano Co., Jacksonville, Fla.	1210	248
WABH	Lake Shore Tire Co., Sandusky, Ohio	1250	240
WBBA	Newark Radio Club, Newark, Ohio	1250	240
WBBC	Sterling Radio Equipment Co., Sterling, Ill.	1310	229
WCBB	K & K Radio Supply Co., Greenville, Ohio	1250	240

## DELETIONS FROM MARCH 19 TO APRIL 30

KDYB	Salt Lake City, Utah	WEAC	Terre Haute, Ind.
KDYY	Denver, Colo.	WEAE	Blacksburg, Va.
KDZA	Tucson, Ariz.	WEAW	Anderson, Ind.
KDZL	Ogden, Utah	WFAD	Salina, Kans.
KDZM	Centralia, Wash.	WFAS	Fort Wayne, Ind.
KDZZ	Everett, Wash.	WFAV	Independence, Kans.
KFAS	Reno, Nev.	WGAB	Houston, Tex.
KFBV	Colorado Springs, Colo.	WGAK	Macon, Ga.
KFCC	Wallace, Idaho	WGAT	Lincoln, Nebr.
KFGG	Astoria, Ore.	WIAZ	Miami, Fla.
KHD	Colorado Springs, Colo.	WLAM	Springfield, Ohio
KLP	Los Altos, Calif.	WMB	Auburn, Me.
KOG	Los Angeles, Calif.	WNAK	Manhattan, Kans.
KON	San Diego, Calif.	WNO	Jersey City, N. J.
KQP	Hood River, Ore.	WAOQ	Portsmouth, Va.
KXS	Los Angeles, Calif.	WOAY	Birmingham, Ala.
KZC	Seattle, Wash.	WOZ	Richmond, Ind.
KZI	Los Angeles, Calif.	WPAV	Laurium, Mich.
WAH	El Dorado, Kans.	WPAX	Thomasville, Ga.
WBAG	Bridgeport, Pa.	WRAJ	Pittsburgh, Pa.
WCAP	Decatur, Ill.	WSAS	Lincoln, Nebr.

## What Would You Like to Have in Radio Broadcast?

The editors would be pleased to hear from readers of the magazine on the following (or other) topics:

1. The kind of article, or diagram, or explanation, or improvement you would like to see in RADIO BROADCAST.
2. What has interested you most, and what least, in the numbers you have read so far.



Eighteen Years of Amateur Radio

# RADIO BROADCAST

V. 3, 4

In Touch with the World from the Arctic

August, 1923

V. 3 # 4

Porto Rico Fan Wins  
"How Far?" Contest

Sets for Summer

25 Cents

A Practical  
Super-  
Heterodyne  
with 199's



Thos E Monroe

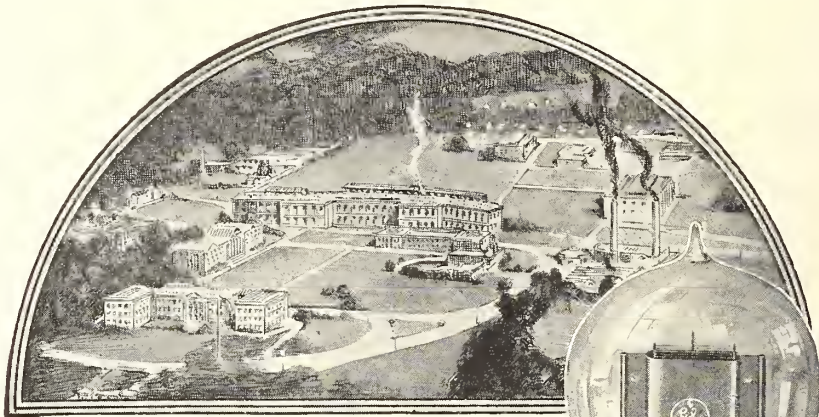

**One of the World's  
Largest Manufacturers  
with unlimited resources  
Builds Cunningham Tubes**

**F**ORTY-THREE years ago the carbon filament electric lamp, at that time considered the finest development in the electrical art, came into general use.

The important and ever-growing demand resulted in the building and expansion of mighty factories, and the improvement of factory methods, until to-day the tungsten filament gas-filled lamp yields eight times the candle power for the same electric input.

In recent years these same highly skilled manufacturers have been devoting a part of their factories, and applying their engineering talent gained through years of experience, to the production of vacuum tubes.

The new Cunningham type C-301-A, Amplifier and Detector represents a combination of these years of manufacturing experience, and the engineering ability contributed by that great scientific organization, the Research Laboratory of the General Electric Company.

The low filament current of only one-fourth of an ampere and the extremely high mutual conductance of 700 micro-mhos, make the C-301-A the most efficient vacuum tube ever built for amateur and entertainment use in radio.

**Patent Notice:** *Cunningham tubes are covered by patents dated 11-7-05, 1-15-07, 2-18-08, and others issued and pending. Licensed for amateur, experimental and entertainment use in radio communication. Any other use will be an infringement.*



*A Specially  
Designed Tube  
For Every  
Radio Use*

*E. J. Cunningham Inc.*

**Home Offices:**  
248 First Street  
San Francisco, Calif.

**Eastern Representatives:**  
145 West Lake Street  
Chicago, Illinois

★ Tested and approved by RADIO BROADCAST ★





## Perfect Performance Guaranteed

Ace Type V, Armstrong Regenerative Receiver—\$20—Formerly known as Crosley Model V. For performance no receiver at its price can equal it.

A man writing from Evansville, Ind. says, "The other night I tuned in Kamach, Hawaii and held the concert for one hour. The music was clear and the speaking distinct." Quite a tribute.

Ace Receivers are licensed under Armstrong U. S. Patent 1,113,149. All Ace sets are equipped with the Crosley multistat, the universal filament control rheostat for all makes of tubes.

Wave length range 200 to 600 meters.

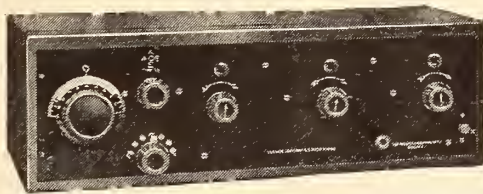

### Announcement

**ACE** TYPE 3 B  
\$50.

ets and new Crosley Condensers with molded plates. This is one of the latest and most efficient sets on the market for steady performance. Battery cabinet and bench can be furnished as extra equipment if desired. There is also a Model 3 B portable for camping trips and outings.

Live Jobbers and Dealers are taking advantage of the sales these instruments and other Precision instruments and parts are bringing them.

*Free Catalogue on Request*



## THE PRECISION EQUIPMENT COMPANY

POWEL CROSLY, Jr., *President*

820 Gilbert Ave.

Cincinnati, O.

# Radio Broadcast

ARTHUR H. LYNCH, EDITOR



## CONTENTS FOR AUGUST, 1923

<i>An Aid in the Fight Against Crime</i> - - - - -	<i>Frontispiece</i>
THE MARCH OF RADIO - - - - -	J. H. M. 269
IN TOUCH WITH THE WORLD FROM THE ARCTIC - - - - -	BURNHAM McLEARY 282
A DRY-CELL TUBE LOOP SET FOR LOCAL RECEPTION - - - - -	ALEX. V. POLSON 288
EIGHTEEN YEARS OF AMATEUR RADIO - - - - -	GEORGE E. BURGHARD 290
"SELLING" THE PUBLIC ON BETTER CITY GOVERNMENT - - - - -	J. L. SIMPSON 299
ADVENTURES IN RADIO—When Messina was Destroyed - - - - -	303
PORTO RICO FAN WINS "HOW FAR?" CONTEST	
A Neighbor at Three Thousand Miles - - - - -	RICHARD BARTHOLOMEW 304
UNLOADING THE MAIL FROM THE TRANSATLANTIC LINERS - - - - -	M. G. CARTER 311
THE GRIMES CIRCUIT WITH OUTDOOR ANTENNA AND COUNTERPOISE	
	HERBERT E. DILL 314
RADIO ANGLING AND FISHERMAN'S LUCK - - - - -	THE REV. H. F. HUSE 316
CRYSTAL RECEIVERS ARE WELL WORTH WHILE - - - - -	ZEH BOUCK 319
POWEL CROSLY, JR. "THE HENRY FORD OF RADIO" - - - - -	ALVIN RICHARD PLOUGH 323
RECEPTION DE LUXE - - - - -	A. R. BOSCOW 325
TEACHING SCHOOL FROM A BROADCASTING STATION - - - - -	LLOYD JACQUET 331
A TABLET DEDICATED TO THE RADIO CONGREGATION - - - - -	332
ALL BOY SCOUTS, ATTENTION! - - - - -	335
SETS FOR THE GREAT OUTDOORS - - - - -	A. HENRY 336
A PRACTICAL SUPER-HETERODYNE WITH 199'S - - - - -	WALTER VAN B. ROBERTS 340
A NEW REGENERATIVE RADIO-FREQUENCY COMBINATION - - - - -	ROGER A. WEAVER 346
THE GRID—QUESTIONS AND ANSWERS - - - - -	350
ADDITIONAL BROADCASTING STATIONS IN THE UNITED STATES - - - - -	352
NEW EQUIPMENT - - - - -	354
AMONG OUR AUTHORS - - - - -	356

Copyright, 1923, by Doubleday, Page & Co. All rights reserved  
TERMS: \$3.00 a year; single copies 25 cents

F. N. DOUBLEDAY, Pres.

RUSSELL DOUBLEDAY, Sec'y.

ARTHUR W. PAGE, Vice-Pres.

S. A. EVERITT, Treas.

NELSON DOUBLEDAY, Vice-Pres.

JOHN J. HESSIAN, Asst. Treas.

## DOUBLEDAY, PAGE & CO.

THE WORLD'S WORK  
CHICAGO: People's Gas Bldg.

COUNTRY LIFE

THE GARDEN MAGAZINE  
GARDEN CITY, N. Y.

SHORT STORIES

EDUCATIONAL REVIEW

NEW YORK: 120 W. 32nd Street

BOSTON: Tremont Bldg.

LOS ANGELES: Van Nuys Bldg.



# Radio "Blind-man's Buff"

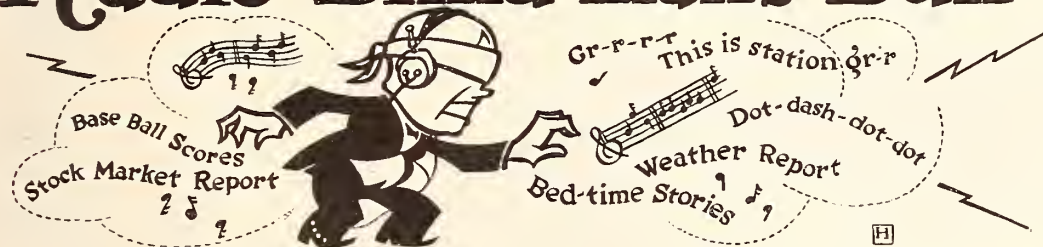

Picking your program with a single circuit receiver is a whole lot like playing blind-man's buff. You're not sure what you'll catch—nor how long you'll hold it.

In the midst of the entertainment you selected some other broadcasting station is quite likely to cut in and spoil the fun.

Selecting your radio equipment with your eyes open avoids this nuisance of jamming and scrambled messages.

Any radio-wise amateur will tell you that there's no comparison in genuine satisfaction between a single circuit instrument and the Paragon three-circuit receiver.

# PARAGON

Reg. U. S. Pat. Off.

## RADIO PRODUCTS ★

The amateur will tell you that the Paragon three-circuit receiver, because of its great superior selectivity and sensitivity, can pick and choose between broadcasting stations of about the same signal strength with less than one per cent differential.

This means that with a Paragon receiver you get what you want when you want it—complete messages and clear music from the station you tune in on, without interruption and jamming. Until you have listened in with a Paragon three-circuit receiver, you cannot guess the real pleasure and fascination of radio.

Long before broadcasting popularized radio with the general public, Paragon equipment was the choice of the experienced amateur. He will tell you today that if you want quality and satisfaction, Paragon Radio Products are the best and safest buy on the market.

*An illustrated Catalog of Paragon Radio Products Is Yours For the Asking*

DEALERS—The Adams-Morgan Company has an interesting proposition to make to reputable radio dealers who believe in quality merchandise. Details on request.

ADAMS-MORGAN COMPANY  
 10 Alvin Ave., Upper Montclair, N. J.

Type RD-5 Regenerative Receiver and Detector—\$75.00  
 Type A-2 Two-Stage Amplifier—\$50.00  
 (Licensed under Armstrong Patents.)

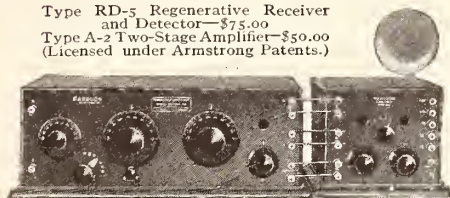

### Also Manufacturers of PARAGON

Radio Telephone	Amplifier
Transmitters	Transformers
V. T. Control Units	Control Dials
Rheostats	Amplifiers
Potentiometers	Receivers
V. T. Sockets	Switches
Detectors	Variometers



AN AID IN THE FIGHT AGAINST CRIME

The New York Police Department has installed receiving apparatus on some of its automobiles and motorcycles, making it possible to receive orders sent from the powerful broadcasting station at Police Headquarters



# RADIO BROADCAST

Vol. 3 No. 4



August, 1923

## The March of Radio

### BUYING SETS ON THE INSTALLMENT PLAN

**T**HERE are undoubtedly many homes where a good receiving set would be welcome, which have up to now missed the evening's radio entertainment because of the rather high cost of a good radio outfit. To get the sort of apparatus which will operate a loud speaker satisfactorily requires in the neighborhood of \$200, including a good loud speaker. For the set alone it will be necessary to give, perhaps, \$125, if stations a thousand miles distant are to be picked up with any degree of ease and certainty.

Now such an expenditure is often impossible in the form of a cash payment and one wide-awake company—The American Radio and Research Corporation—has realized this and by associating itself with a reputable credit house, has arranged to sell its sets so that they are available to the public on the partial payment plan. A 10 per cent. deposit for the set, and time payments extending over a year, will enable the family to enjoy radio while they are paying for the set. Of course many people feel that if they cannot afford to pay cash for an article, they cannot afford it at all; to these, the scheme offers nothing. But there are thousands of families willing to go into a contract to pay for some luxury, who would have to do without it if the contract plan were not in existence. This fact is evidenced by the tremendous popularity of the partial payment plan in the automobile industry; probably

more than half the cars purchased to-day are obtained in this manner. And, we may ask, how many of us pay cash for our homes?

Those who depend upon the small boy of the family to buy the parts and assemble the set are probably fairly well "sold" by this time; but a purchasing public, numbering millions, is still to be equipped with radio. With new stations going up, and the programs of the older ones continually increasing in excellence, this part of the public is waiting to purchase radio sets which require no tinkering nor complicated adjustments before they are ready to provide entertainment. These sets will, for some time to come, probably be sufficiently expensive to warrant the use of the policy of delivering the goods to the customer for a very small payment and relying on the pleasure which is had by the purchaser, to keep further payments coming in on time.

Incidentally, this will do much to help kill off the poor trash on the market, because if such apparatus is bought on the installment plan, the family will sacrifice the first payment and give back the set rather than continue to pay for something which is not what it is represented to be.

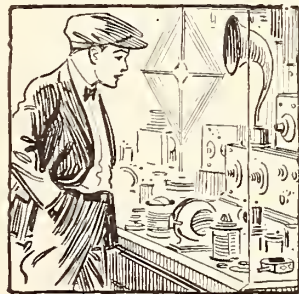

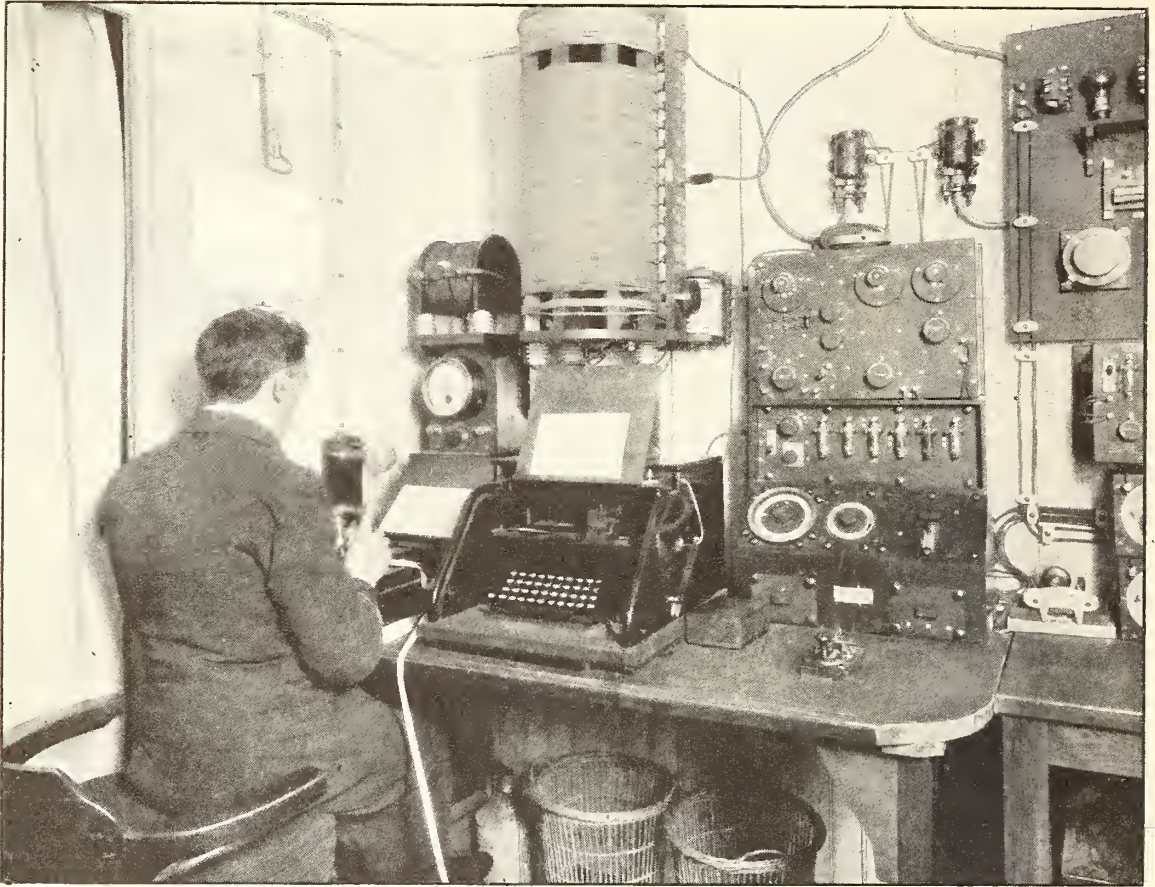

PREPARING MESSAGES TO BE SENT AT 80 WORDS A MINUTE

This operator, on the S. S. *Majestic*, is using a perforating machine to make records of radio messages on a tape. The work is done at a time when traffic is slack. When the ship nears port and a great deal of business has to be rushed through, the tape is fed into an automatic transmitting apparatus and buzzed off in short order

### Music Publishers With Vision

WE HAVE several times had occasion to express our disapprobation of the action of the popular music writers in prohibiting the broadcasting of any of their compositions without the payment of rather large license fees. The recent action of the Radio Corporation in cutting out from their programs all compositions controlled by the Society, evidently verified our guess that this grasping after revenues, where none was in sight, would react to the detriment of these composers and publishers. It is with real pleasure that we now record the action of another group of music composers and publishers; producers of the so-called "standard" music, as contrasted to the "popular" variety.

In a report on the subject of broadcasting, a

committee of the Music Publishers' Association of the United States says: "Our committee has been carefully investigating the broadcasting of copyrighted music since last November. In our report, just adopted by the Association, we point out that music publishers are vitally interested in radio broadcasting as a great future user of music and that our rights in the use of copyrighted music in public performances must be protected. However, we appreciate the fact that radio broadcasting is still in a chaotic and experimental state, and that while ultimately it will have to be placed on a commercial basis if it is to develop its potentialities, nevertheless the commercial side of the broadcasting problem has not yet been solved.

"In view of these facts, and also because we desire to coöperate in developing the music possibilities of radio, we believe that we should allow the use of our copyrighted compositions





SOME OF THOSE RESPONSIBLE FOR THE NATIONAL ASSOCIATION OF BROADCASTERS

Left to right: J. E. Jenkins, of WDAP, Drake Hotel, Chicago; Frank J. Elliot, WOC, Davenport, Iowa; Henry Ramsey, Chicago Board of Trade; Thorne Donnelly, WDAP; E. F. McDonald, Jr., WJAZ, Edgewater Beach Hotel, Chicago; and W. Johnson, WFV

for broadcasting without charge for the present and without prejudice in our rights."

In another part of the report the musical possibilities of radio are hinted at and present defects mentioned; altogether the report shows keen analysis and liberal judgment of the members of this organization, and we heartily recommend its perusal (especially the italicized part) by the more short-sighted members of the American Society of Composers, Authors, and Publishers.

#### Will the Composer Pay for Broadcasting?

**M**ANY and varied have been the suggestions volunteered to solve the question—who is going to pay for broadcasting? This was the subject of our first editorial in the very first number of our magazine; it seemed at that time the one important question involved in the future development of radio, to which no satisfactory workable answer had been given. To-day, more than ever, this question is uppermost in the

minds of those concerned with the future of broadcasting.

There are two large organizations interested in the question which can get along indefinitely with conditions as they are: undoubtedly the Radio Corporation has a large income from the sales of tubes and sets, and the American Telephone and Telegraph Company can charge up its broadcasting expense to development without seriously reducing its dividend. But there are scores, or even hundreds, of broadcasting stations which cannot continue in this fashion. Their future is not promising unless some source of revenue is found and found soon. This is especially true since the popular music writers have begun to insist on their royalty rights and want to collect money where there is none.

Now, the American Society of Composers, Authors, and Publishers undoubtedly numbers among its members many of the better writers and composers of popular music, but we have wondered of late if it were not possibly adopting tactics like those of some labor unions, suppressing potential talent so that those in the



Society might better control the dividend sources. Although we have never tried the experiment (not having sufficient gift along musical lines) we imagine that a new song and score writer, not in the Society, and not wanted in it, might have quite a difficult time getting his wares on the market. If this is so, the scheme outlined in the pamphlet before us may succeed very well, and in succeeding, indicate at least one way in which broadcasting may be made self-supporting.

A group of broadcast managers have combined to form the nucleus of the National Association of Broadcasters. The proposed constitution and by-laws are well drawn up and show the executive ability of the organizers. Membership in the Association is suitably divided into classes, and other formalities are taken care of properly, such as membership fees, schedules for broadcasting, and care of

*surplus funds.* The mention of this last item started us thinking. Surplus funds from the operation of a broadcasting station!

Well, here's the idea. Musical genius is to turn over its compositions, properly copyrighted, to the Association—for nothing. The Association will, through its members, put the composition "on the air" and so bring it at once to the public's attention and if the listeners think the stuff is good the composer's product is "sold." The composer begins to reap his royalties from the publication and sale of his music, and the Association, as its reward for putting the music before the public, is to get the mechanical royalties—those reaped from phonograph records and roll music. When the composer turns his work over to the Association to broadcast, these mechanical royalties are conveyed to it in the contract.

This looks like a very good scheme, and we



RESERVE OFFICERS AT CAMP VAIL, NEW JERSEY

Using an outfit with a collapsible loop. With this little machine it is possible to send and receive, even though located deep in a dug-out. This set was developed by William Preiss during the War



shall watch its development with interest. All stations represented in the Association will send out the compositions contracted for by the society, on a schedule arranged by the Board of Directors, so that a definite, known advertising campaign is assured to the composer. It is for the best interests of both parties to the contract that the new piece be "put over", because both benefit from large sales. As far as we can see, composers and broadcasters alike have everything to gain and nothing to lose in trying out the scheme. If it works, as we hope it will, societies like the A. S. C. A. P., which have been so insistent on radio royalties, will have to look elsewhere for funds to pay their eminent counsel.

In outlining the need for this society, one of its organizers informed us of the following incident, which, he maintains, is but one of a number:

An author sold one of his compositions to a Chicago music house. It remained dormant for a long time. Later, arrangements were made with a broadcasting station to have the author sing his own song. It made quite a hit and has enjoyed a good sale. Radio has actually brought this author out of obscurity. Then, because the author had made an arrangement with the A. S. C. A. P., he was prevented from singing his own song at all radio stations that failed to pay royalties to his society.

The new Association is made up of some of the leading broadcasters in the country and they have very good ground for the belief that they are in a position to popularize their own songs. Powel Crosley, Jr., a member of the Association, has already started a music publishing company and the first song to be popularized by radio is now being put on the air. Is this the handwriting on the wall?

### The Effect of Broadcasting on the Churches

ON TWO recent occasions we have commented on the effect of broadcasting upon church attendance. It is evident that effects of considerable importance may be looked for. We had ventured the guess that the smaller churches would probably lose in attendance as the worshippers at these small country churches, with their itinerant pastors, came more directly in contact with services at the larger metropolitan church with their wonderful music and inspiring

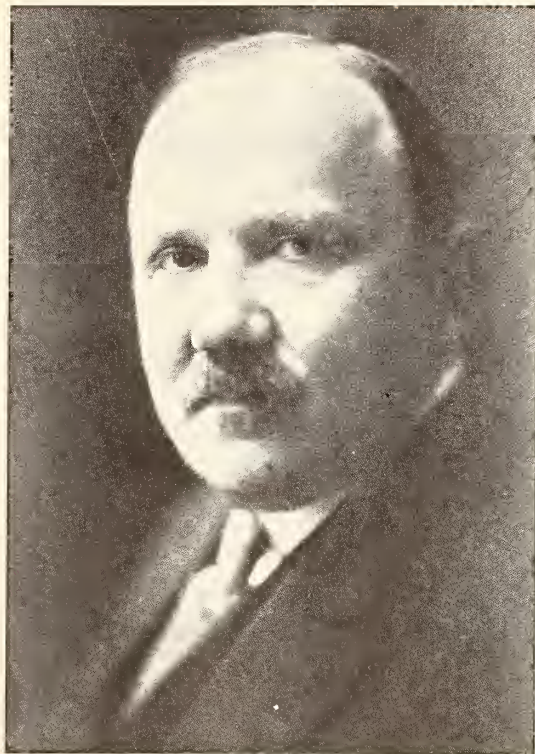

THE HONORABLE ERNEST LAPOINTE

Canadian Minister for Radio. He is to supervise the activities of the twenty-odd broadcasting stations and arrange for the collection of the \$1.00 tax levied on every broadcast receiver. It is estimated that there are more than 150,000 receiving sets in use in Canada at the present time

preachers. It seemed to us, also, that an argument might be found on the other side of the question: the country pastor, ordinarily having but little contact with the larger churches, administered by the more capable preachers of his denomination, might himself install a receiving set, and so gain ideas and inspiration for his own services. Ordinarily, he is dependent upon the printed word for his sermons, but by radio he is put directly into the audience of the best thinkers and speakers of his church. In this way, we believed, he must improve himself, and this improvement might result in the increased interest of his own little band of worshippers.

These were only guesses, as most of the opinions on the effect of radio broadcasting must be for some time; but that the guesses come somewhere near the mark would appear from a recent letter in which an Episcopal bishop voices his ideas on radio. The letter is from Bishop Stearly, and reads as follows:



USING A YOUNG BLIMP TO SUSPEND THE ANTENNA

Mr. Roy Knabenshue, of Burbank, Calif., a pioneer aeronaut, constructed this 14-foot balloon, filled it with hydrogen, and sent it up with 200 feet of antenna wire attached. Using a commercial two-stage receiver, he claims to have received various broadcasting programs with greater clearness than when using a horizontal antenna suspended in the ordinary way. Mrs. Knabenshue and Mr. R. W. Coburn (on either side of Mr. Knabenshue) assisted in the experiments

The wide-spread use in private homes of the wireless apparatus lays a fresh responsibility upon the clergy and laity in regard to services of the church. It is debatable whether the broadcasting of sermons of popular preachers and of entire church services will act as a stimulant or a deterrent to church-going.

Why go to your parish church when you can sit at ease in your parlor and hear the heavenly music of a capable choir and be charmed by the fervid eloquence of a magnetic preacher?

There seems to have entered into our crowded and throbbing life another ally of those forces which make difficult the assembling of the faithful for praise and prayer. The habit of church-going has a hard time in the face of Sunday excursions, movies, sacred concerts, automobiling, and broadcasting.

What this means to us, I suspect, is, at the bottom, a challenge to our ingenuity, wisdom, and devotion. None of these things, nor all of them together, can fill the deepest need of the spirit in man,

and in the church, in its worship and teaching and work and fellowship, are the potencies capable of bring to men the highest satisfaction, the deepest and most abiding joys.

Now it becomes necessary for the clergy to make the church more attractive than the world's entertainments, to discover to men the possibilities within it for strength and refreshment, and the gifts of grace in its bestowing, more precious than earthly things.

#### Broadcast Central, Comprising WJZ and WJY

THE past month saw the opening of probably the best equipped radio broadcasting station in America, the Radio Broadcast Central of the Radio Corporation of America. It is located on the top of Aeolian Hall, one of New York's tall buildings in the



centre of the city. Trouble from power absorption in the neighboring buildings, and poor radiation, might have been anticipated, but from results so far reported the station seems to function excellently.

The Radio Corporation's previous broadcasting station, WJZ, located in Newark, a dozen miles from New York, was extremely inaccessible to lecturers and performers. This drawback was partially remedied by fitting up a studio in New York City, and sending the voice currents by wire to the radio station. But this scheme gave much trouble; the wires used were leased from the Western Union Telegraph Company, and in spite of assurances that they were "as quiet as it was possible to make them," noises of all sorts were picked up by them between the studio and the transmitting station. In fact, on the night when they were first put in commission, while the

Western Union official was telling us—via radio—how quiet his wires were, they were picking up so much extraneous noise, unknown to him, that his words were scarcely intelligible.

A studio and radio transmitter should be as close together as it is possible to make them, because wire connections between them even under the best conditions *will* pick up *some* disturbing "electrical noises." Broadcast Central's studios (there are two of them) are directly under the antenna, so that trouble from this source has been eliminated.

Two antennas, suspended from the same masts, lead to two entirely separate transmitting sets, each of which has its own control equipment. Each studio controls one of the antennas, and as these and their respective transmitters are tuned for different wavelengths, both studios and antennas may operate simultaneously without interference. This

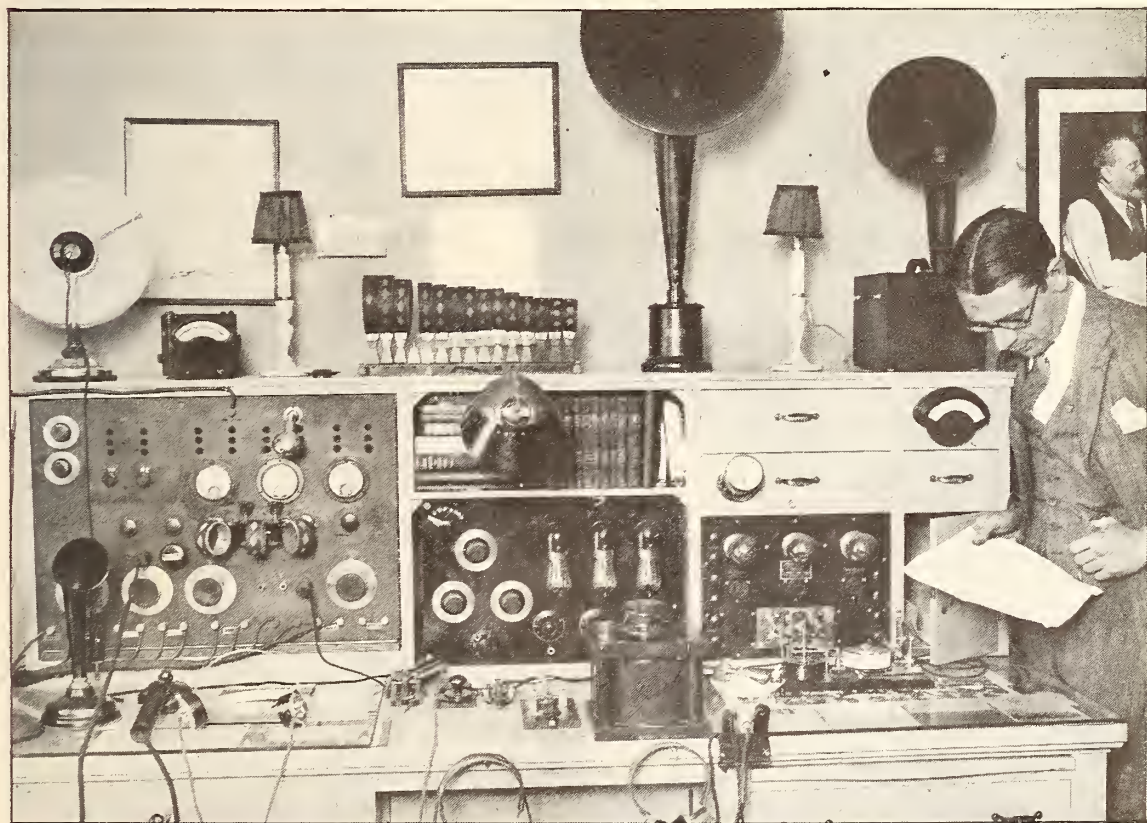

A PLACE FOR EVERYTHING AND EVERYTHING IN ITS PLACE

Amateur station 2ABT, owned by Mr. George Freisinger of New York. It is one of the most elaborate in the East, and its performance is in keeping with its appearance, as Mr. Freisinger (at right of picture) has heard stations in Europe as well as all over America. The 300-watt transmitter is not shown, but the combination transmitter and receiver of the navy type, using 20-watt Singer tubes for transmitting, and a standard honeycomb regenerative hook-up with two stages of amplification for receiving, is mounted on the desk at the left. In the centre is a special type amateur receiving unit with two stages of A. F. amplification. At the right, is a three-stage power amplifier



is the first time such a system has been introduced into the broadcasting game.

These paragraphs do not pretend to give a technical description of WJY and WJZ, but one very ingenious scheme of control does warrant mention here; the visual control of the amount of modulation of the antenna current. The high-frequency antenna current is rectified by a tube outfit and thrown on to an oscillograph screen, and a wavy line of light shows the operator exactly how much the antenna current is being varied by the singer's voice. Moreover, this operator has at his immediate command the control of the amount of modulation sent to the antenna—if a singer puts too much fortissimo into her voice so that the antenna current would be modulated too much to sound well, the effect of the voice on the antenna current can be at once (and unknown to the singer) cut down, thus tem-

pering the singer's effect on the transmitter. The idea is very much like having an orchestra perform in a room enclosed by shutters which could be opened or closed by a listener outside; if the performers put too much intensity into their playing the outside listener could close the shutters when they played too loudly and open them when the softer passages were being executed.

Some such control over radio modulation is absolutely essential if the quality of the received signal is to be good. While one performer will sing with tremendous volume, and stand close to the microphone, the next, standing farther from the microphone and singing with less force, may scarcely affect the antenna current. The engineers of the Radio Corporation are to be congratulated on the method which they have developed to solve this problem.



THE FIRST DEMONSTRATION OF THE RADIO TAIL-E-PHONE

The scene is laid in Leadville, Colorado, in 1905, when Mr. C. B. Cooper (sitting on the apparatus) was Superintendent of Construction for the United Wireless Company. Mr. Cooper is now a member of the Hoover Conference Committee, the Board of Governors of the National Radio Chamber of Commerce, and Chairman of its Broadcasting and Finance Committees, and Treasurer of the Radio Broadcasting Society of America. In 1917, he left construction work to organize the Ship Owners' Radio Service, in Seattle. Recently he started the C. B. Cooper Company, Factory Representatives.

His company acts as New York representative for the Crosley Manufacturing Company



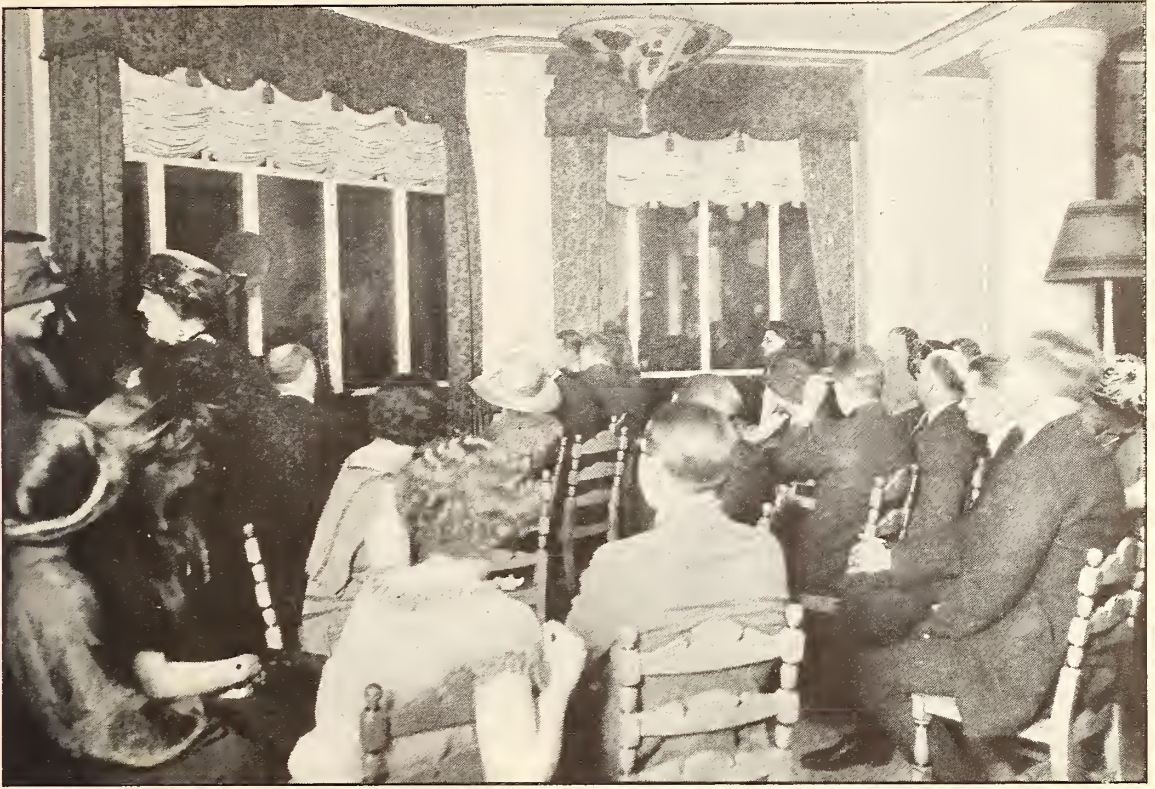

LISTENING TO WJAZ FROM JUST OUTSIDE THE STUDIO

Guests at the Edgewater Beach Hotel, Chicago, can see the broadcasters through the windows at the left and the control room operators through the windows at the centre. At the same time, they can listen to the program by means of a receiver and loud speaker

### Secretary Hoover Acts

WE BEMOANED the failure of Congress to act on the White bill, by which the broadcast situation was to be remedied; but before the echo of our moans had died away we found the situation suddenly remedied without the White bill! Apparently feeling that it already had sufficient authority, and that the situation was bad enough to warrant immediate action, the Department of Commerce, acting in accord with the opinion of the radio experts and authorities of the country, has reassigned frequencies to practically all the broadcasting stations in the country and has done it so well that we no longer have any cause for complaint. Instead of the bedlam of noise to which we had become almost accustomed, there is practically no interference at all. With a good receiving set, one can go through the range of wavelengths assigned to broadcasting and pick up perhaps twenty stations with no appreciable interference.

To be sure, it was possible for the expert, even under previous conditions, to get rid of much of the interference, because no two stations sent on exactly the same wavelength, and by using two- and three-circuit tuners with just the right amount of regeneration, he was able to cut out many of the disturbing stations. Most of us, however, were not sufficiently expert, and didn't have sufficiently complicated sets (and didn't want them, either) to do such fine tuning. But now no such skill is required. Even the novice can eliminate practically all interference; and the concerts, ever improving in quality, are really worth while staying at home to hear. The finer passages are not spoiled by the whining beat note of a competing station, as they formerly were.

With this re-assignment of wavelengths, a big step has been taken in forwarding the interests of radio broadcasting; considering the apparent ease with which it was accomplished we wonder more than ever why the Department of Commerce delayed its good work so long.





#### THE BOOM IS ON IN ENGLAND

And manufacturers are hard-put to supply the increasing demand for broadcast receivers. These women are doing light assembly work at the Marconi Works in Chelmsford

#### The Interdepartmental Radio Advisory Committee

FROM the Department of Commerce we have received a bulletin describing the successful functioning of the committee of representatives from all governmental departments having a serious interest in radio communication. For some time past various departments have been doing more or less broadcasting, and as it seemed only consistent with the Federal Government's activities in other branches of coordinating the work of various government sub-divisions to cut down expense and interference, Secretary Hoover brought about in April, 1922, the formation of the Interdepartmental Radio Advisory Committee, which we discussed in these columns about a year ago. The scope of the Committee's activities was widened in January of this year to include not only questions of methods of, and material for, broadcasting, but all other radio matters in which the several departments may be interested.

The Chairman of the Committee is Acting Assistant Secretary S. B. Davis of the Department of Commerce, and he has with him repre-

sentatives of the Departments of Agriculture, Interior, Justice, Labor, State, Treasury, War, and Navy, Bureau of the Budget, Interstate Commerce Commission, Post Office, and the Shipping Board. Whereas the power of this committee is purely advisory, its members have cooperated so harmoniously that no matter has yet been brought up for consideration which has not been amicably solved. As its fundamental principle in controlling the extension of governmental radio activities, the committee has wisely concluded "that radio broadcasting should not be used where wire telegraphy or telephony or printed publication would be as satisfactory."

In the words of the bulletin, "the several departments feel that the committee has been a satisfactory clearing house for government radio matters. While the experimental broadcasting system has operated satisfactorily to date, the experience which has been had with it should be used as a basis of a rational plan for a government broadcasting system. The question is, of course, intimately related with the existing and prospective privately owned broadcasting stations throughout the country. If radio is to become of maximum benefit to



the people, the Government must continue to study the question of properly organized broadcasting and other services. There are constant occasions for the curtailment or expansion of the Government's radio plant and the committee's effort is to coordinate these needs and fulfill them with maximum economy."

### Radio Repays its Genius

**T**O THOSE who have followed, even superficially, the development of radio in America, the name of Alexanderson is well known. The contributions which have come from him and his co-workers are many and varied; his work is not apparent in the receiving sets with which most of us are familiar but deals rather with the engineering features of radio. The reduction of losses in the huge insulators used in suspending the large antennas of the Radio Corporation's transmitting stations, the ingenious scheme for reducing earth losses of an antenna by his "multiple tuning" method, the magnetic behavior of iron at the excessively high frequencies used in radio, and the design and construction of the immense high-frequency alternators which bear his name, serve to illustrate the type of work which this engineer is contributing to the advancement of this branch of electrical engineering.

He now undoubtedly feels repaid a thousandfold for the energy he has devoted to radio research, as will be evident from the following narrative from the News Bureau of the General Electric Company:

Monday, April 30, Verner, six-year-old son of Dr. Alexanderson, was lured from his home by the promise of a gift of rabbits, and kidnapped. The police had practically no clue to work on; in spite of the active work and close cooperation of the newspapers, police, and radio broadcasting stations, the case appeared to be at a standstill and the whereabouts of the boy remained a mystery for three days.

Bert Jarvis, of Theresa, Jefferson County, N. Y., a village of a thousand inhabitants, listening-in Monday night on his home-made radio set, heard WGY, the Schenectady broadcasting station of the General Electric Company, announce the kidnapping of Verner Alexanderson. Jarvis rents boats to fishermen and acts as caretaker for numerous summer cottages in the vicinity of Theresa. A few days before the kidnapping, he had rented an



DR. ALEXANDERSON AND HIS SON

isolated cottage to a man who was bringing his family up from the city for the season.

After hearing the radio description of the missing boy and the kidnapper, Jarvis's suspicions were aroused. Tuesday he met the owner of the cottage and asked him who had taken possession. The owner explained that it was only an old woman, a little boy, and one man.

It so happened that the man when renting the cottage had said that he was going to bring his daughter. Jarvis's suspicions grew and Wednesday he decided to ride out to the vicinity of the cottage in his motor boat. He stopped at the cottage and asked the old woman who came to the door for a glass of water. He entered the house and saw a child on the bed. Jarvis returned to the cottage later and asked for candle wicking for his motor. On this visit he waved to the boy and the boy waved at him.

Thursday morning, Jarvis saw a photograph of the kidnapped boy in the *Syracuse Post Standard* and this picture tallied with the boy in the cottage. Now sure of his ground, Jarvis reported to the Deputy Sheriff and a few hours



HOMeward BOUND WITH THE CAVE-MAN SET HE MADE AT SCHOOL

This English youngster is eager to see what's on the air down in London. The apparatus looks a bit primitive but it's easy to "get at," at least

later Verner talked over the long distance telephone to his father and mother.

The successful use of radio in the Alexander-son case has convincingly proved the value of broadcasting as a publicity factor when far-reaching results are desired in a short time. WGY announced the kidnapping within two hours after it had been reported to the police. Other broadcasting stations joined their voices to the voice of WGY, and the story, with a description of the missing boy, went over the entire country. Radio fans were everywhere enlisted in the search. The newspapers kept them posted on the progress of the case and also furnished them with pictures of the boy. Through Hudson Maxim, the members of the Amateur Relay League took up the case and hundreds of spark sets flashed the story through the air.

Dr. Alexanderson made a personal appeal from the Schenectady broadcasting station. After the boy had been found he again addressed the radio audience thanking everyone for his interest, sympathy, and assistance. He placed special emphasis on the cooperation of the press and police.

## West Coast to Have a New Station

THE General Electric Co. has started work on a new broadcasting station to be located in Oakland, Cal. Most of the broadcasting stations to date have been fitted up in more or less makeshift quarters in buildings already erected, but this new Western station is to be built for radio from the ground up.

Research is being carried on to determine how reverberatory an ideal studio should be; a room having no echoes at all gives the transmission a peculiar empty quality, whereas too much echo from walls and ceiling makes the speech unintelligible and accentuates severely certain musical notes.

A small power house for the radio apparatus will be built below the antenna, which will be of the multiple tuned type. An interesting feature of the new station is the use of water-cooled triodes for the oscillator and modulator; although the normal antenna power from these tubes will be only 1000 watts, the possible output, to be used for test purposes, will be many times as much.

It is expected that the programs will be broadcasted not only from artists in the station studios, but that also, by suitable wire connections provided by the Pacific Telegraph and Telephone Company, any of the interesting events taking place in San Francisco, the West's metropolis, will be put on the air!

## The U. S. Health Service Functioning by Radio

THAT radio is surely becoming one of the very necessary factors in our every-day life is evidenced by the following recent note from the U. S. Public Health Service:

The steamship *West Cabous*, lying at anchor in Baltimore harbor, about nine miles from the city, needed medical help at about 3 a. m. recently and needed it quickly. A member of the crew had fallen into the hold and injured himself seriously. So the captain of the ship sent a wireless broadcast asking help.

The call was picked up, not in Baltimore, nine miles away, but at Cape May, about 100 miles due east of Baltimore. As Cape May was separated from the *West Cabous* by parts of New Jersey and Delaware and by the eastern shore of Maryland, not to mention Delaware and Chesapeake bays, no direct help from it was possible.

But the operator was on the job. Promptly he consulted the long distance list in the Baltimore telephone directory and called up the residence of



the Public Health Service, Surgeon-in-Charge of the Marine Hospital in Baltimore—100 miles to the west. The surgeon, roused from sleep to receive the message, asked him to radio certain emergency treatment to the *West Cabous* and to direct the captain to send a boat to a certain pier in Baltimore, where he would find a surgeon waiting to go to the ship with him. And so, in the middle of the night, in less than an hour from the time the call for help was sent, a sea-going ambulance carrying a Public Health Service officer reached the side of the injured sailor.

### Good News For Our Readers

EVERY one really interested in the development of radio realizes that to understand its problems a knowledge of its more technical features is most desirable. Of course, we cannot all expect to be radio experts, but we can learn to read, intelligently and with reasonable comprehension, papers dealing with the technical progress on radio.

Those of you who look at radio in this light will appreciate our good fortune in having been chosen by the executive committee of the

Radio Club of America as the magazine to publish the papers presented at its meetings.

In the membership of this club are included nearly all the best-known amateurs in the vicinity of New York. Not only do the members themselves contribute interesting and valuable papers on the various phases of radio, but well known workers in the field from the research laboratories of the large manufacturing companies have always appreciated the honor of being invited to speak before the members, and have gladly done so. We have frequently attended the meetings of the Club and have always come away with added knowledge and renewed enthusiasm for the radio game.

RADIO BROADCAST is to be congratulated on having been selected by the Radio Club of America for the publication of its papers. We believe that the class of readers to whom RADIO BROADCAST appeals is such that the Radio Club may feel sure that its papers are reaching an intelligent and appreciative audience.  
—J. H. M.

### AT CAMP—FOR THE TIME BETWEEN SUPPER AND SLEEP

The large home set can be taken over the hills and far away, when the family chariot does the toting







DR. MACMILLAN AT THE NEWLY INSTALLED SET ON THE "BOWDOIN"





THE "MONARCH OF ALL HE SURVEYS," IN ETAH, NORTH GREENLAND

## In Touch with the World from the Arctic

How Dr. Mac Millan Came to Take Radio with Him to the Far North. The Question of Communication Through the "Auroral Band." How Broadcasts from Civilization will Relieve the Greatest Hardship of the Expedition, and How the Explorers will Flash Back Weekly Code Messages to Civilization

By BURNHAM McLEARY

WHILE you lounge in your easy chair this winter, listening to violins in some distant city, give a thought to the brave ship *Bowdoin*, captained by Donald B. MacMillan, the Arctic explorer; for he and his seven ship-mates will likely enough be listening to that same orchestra and perhaps be dancing to its music on the sparkling ice-fields of the Frozen North.

For radio is on its way to meet the Eskimo.

About a month ago it set out from Wiscasset, Maine, ensconced in the forward end of Captain MacMillan's 89-foot schooner and bound for the northernmost limits of Eskimo Land, hardly three hundred miles from the Pole itself.

And while you are picturing the pleasures which radio will bring to these Arctic explorers,

stand by and listen for the signals of their far-off station. For under the ice-battened hatches of the *Bowdoin*, there is a wireless operator, Donald H. Mix by name, who hails from Bristol, Connecticut; and his hand on the key will be flashing each week a five-hundred word story of adventure (in a special code prepared for the purpose by the Government) to seventy of the leading newspapers and magazines of America. He will transmit, also, coded diagrams of all new lands and harbors found and charted by the expedition. Each message will be signed with the letters WNP. The full name of the sending station, happily christened by the Government, is Wireless North Pole.

It's a great thing for radio, this adventuring into the land of perpetual stillness, undoubtedly the greatest from the standpoint of



DONALD H. MIX, RADIO OPERATOR ON THE PRESENT EXPEDITION

He was selected from a group of many applicants to take charge of the *Bowdoin's* communication with the outside world. He is 21 years old, a graduate of the Bristol High School, Bristol, Conn., and an amateur operator of six years' standing

popular appeal that has yet taken place; and the story of how it all came about adds an interesting chapter to radio history.

On March 21, 1923, Captain Donald B. MacMillan, F.R.G.S., was guest of honor at a dinner given by U. J. ("Sport") Herrmann at the Hotel Sherman, Chicago, and attended by prominent officers of the Naval Reserve. At this dinner Captain MacMillan told of the true hardships of the Arctic—not the cold, not the lack of food, but the awful solitude, so terrible indeed that men go mad because of it. He recalled one expedition in particular when this tragic fate befell a number of the crew and the only way the remainder of the party could get back to safety was to shoot them.

Seated next to Captain MacMillan was E. F. MacDonald, Jr., radio fan and owner of the powerful Edgewater Beach Broadcasting Station.

"Why in the world don't you take along a radio receiving set?" was MacDonald's immediate question.

"Haven't room," replied MacMillan.

"Great goodness, man," said MacDonald, "do you realize how little space a radio set would take up—and don't you see what it would do? I don't mean a radio equipped with ear-phones, but a set with a big loud-speaker that could be heard in all parts of the ship. Why, at a single stroke you would eliminate, by your own testimony, the most terrible hardship of your entire voyage. Your men could listen to the same concerts, the same orchestras, which they would be hearing if they were at home, could get all the news of the day, could even receive direct messages from their families back in civilization. Give me space no bigger than that"—MacDonald measured the limits with his two hands—"and I'll not only furnish the radio that will do all this but have it installed and let you try it out."

"All the space I've got left," said MacMillan, "is four cubic feet. If you can do it in that, go ahead."

This conversation took place in March. Two months later the idea of radio communication had made such appeal to the explorer that he had arranged to take with him not only a standard Zenith receiving set but also a 500-watt Zenith transmitter, and had told the carpenter to rip out four bunks in the forward end of the forecabin to make room for it.

The set selected was located in the laboratory on the second floor of the Zenith plant on the outskirts of Chicago. The motor generator was placed on skids approximately eight feet from the transmitting unit. Leads were run across the floor in a temporary manner and the set was then ready for test. The aerial consisted of 4, wires No. 22, 7 strand, 52 feet long, an exact duplicate of the antenna which was subsequently used on the ship. One porcelain insulator was used at the opposite end. The lead-in was composed of two wires connected to the outside wires and came down over the side of the building spaced five feet away, and in through the top of a window through a formica tube, to the set, the total length of the lead-in being approximately thirty-eight feet. The free end of the aerial was supported on top of an electric sign approximately twenty-five feet above the roof of the building. The opposite end was supported by a long wire attached to the flagstaff which is located in the center of the front of the building and was approximately fourteen feet above the roof. All rheostats and controls for the motor generator were temporarily bolted



to the floor in order to save time in the installation for trial purposes.

When the test was started at 10:30 P.M., the operators immediately started to get in touch with amateur station 1AW. However, 1AW did not find the wavelength until 1:30 in the morning when communication was established through the means of a relayed message from 3JJ. Immediately afterward, Hartford switched their wavelength and caught the testing station and worked for approximately 1½ hours with the ease of being in the same town. At the time the lower wavelength (220 meters) was used, the radiation was 3½ amperes, and on 310 meters 5 amperes. Under full load, the machine delivered 5½ amperes into the antenna on 220 meters, and 6½ amperes on 310 meters.

The  $\frac{6}{10}$  K. W. motor generator was driven by storage batteries of 32 volts, each an exact duplicate of conditions on board the *Bowdoin*. Two 50-watt power tubes were used. During the test the following stations were worked: 1AW, Hartford, Conn.; 8Q, Freeport, Pa.; 3JJ, Washington, D. C.; 6KA, Los Angeles, Calif.; 9BXA, Denver, Colo.; 8AWT, Syracuse, N. Y.; 9ZT, Minneapolis, Minn. (daylight); 9CWB, Columbia, Mo.

Meanwhile, the adventure had so appealed to MacDonald that the explorer invited him to go part way with him and the invitation was accepted; so that even while you read this article, MacMillan and MacDonald are headed toward the North Pole. The latter, however, plans to end his northward journey at the Eskimo village of Hopedale, Labrador, the farthest point from which he can get a mailboat back before ice closes navigation for the winter.

Incidentally, Mr. MacDonald will return to the United States with information of real importance to the success of the expedition, for his personal contact with the crew will have shown him exactly what kind of radio program most appeals to the men and will enable him to put on just such a program once a week at the Edgewater Beach Broadcasting Station in Chicago.

The selection of the operator to accompany radio on its first adventure in the Arctic, forms a story in itself. Strangely enough, it is not physique and ability that are the most important qualifications for success in the Arctic, but personality—the faculty for making oneself congenial in the close quarters of an ice-bound ship. In the search for the right man,



THE CREW OF THE "BOWDOIN" ON HER 1921-22 CRUISE

Hiram Percy Maxim, President of the American Radio Relay League, was appealed to, and his aid was readily enlisted. Mr. Maxim sent out a call for volunteers. Hundreds responded. From this group, five were picked as candidates, the final choice being made by Captain MacMillan.

#### WILL RADIO PENETRATE THE AURORAL BAND?

WITH a single powerful radio station sending messages from Farthest North, opportunity will be afforded for studying certain phases of radio transmission in a way that has never before been possible. For example, there is a period of 141 days during which a message sent at midnight must traverse hundreds of miles of sunlight before it reaches darkness. How will this unusual condition affect the reception of the message?

Again, a request will be issued to all members of the American Radio Relay League to stand by on a certain evening of each week and tune in for Station WNP. What portions of the American continent will receive these messages? Where will they come through clearest? If a line be drawn on the map through the stations that succeed in picking them up, what sort of an arc—if it be an arc—will that line describe? Of especial significance is this latter question, for the reason that never before has

a scientific attempt been made to transmit wireless messages through the "auroral band" which encircles the North Pole, and which, it is believed, will act as a powerful deterrent. In this connection it is hoped that these experiments will shed new light of a purely scientific nature upon that great mystery of the heavens, the Aurora Borealis.

Of the nature of the news that will be flashed to us from out the Arctic, we may gain some inkling from the talks which Captain MacMillan has given in recent months. He tells, for example, of the marvelous Arctic summer, when the weather is mild and emerald fields are agleam with myriads of little twinkling flowers. He tells, also of vast mineral deposits—a twenty-foot vein of coal, for instance, utterly exposed and waiting only for the great airships of the future. Doubtless, too, he will have interesting reports to make of the glaciers of the Far North, now known to be advancing rather than receding, and believed by many to foreshadow for this thriving continent of ours, a return engagement for the Age of Ice.

#### AN APPRECIATION OF THE ESKIMO

MOST interesting of all, however, will be his studies of the Eskimo—in many ways the only remaining specimen to whom humanity can point with pride! Devoted to his wife or wives, kind to his children, reverent always toward his elders, ready always to bring up the orphan as his own, the Eskimo is so free from guile that he may well thank his lucky stars that he has no money, for the white man would surely go after it.

Very naïve is the Eskimo. Shown a telephone set by Captain MacMillan, one of them jabbered into one end of it, just as he had seen the white man do and then ran as fast as he could to the other end, to see if he could hear his own voice coming through. Failing in that, he cut the wire, puzzled over it for a while, and then averred that the whole business was impossible as the wire had no hole in it!



THE "BOWDOIN" FROZEN IN FOR THE WINTER

Note the snow igloos built on the deck of the ship, covering the hatches to retain the warmth



Shown, in motion pictures, the traffic on Fifth Avenue, he exclaimed, "Oh, see the dog sleds that move without dogs."

Naïve, indeed, the Eskimo, but a rather good sort, for all that—and he doesn't have such a bad time of it, either, according to MacMillan.

If an Eskimo baby lives five days, it is almost certain to be good for sixty years—unless it falls through the ice, or gets killed by a bear or a walrus. Except for heart disease and rheumatism, sickness in the Arctic is practically unknown. No good Eskimo would ever think of having such a thing as a "cold."

Time, too, is practically unknown to the Eskimo. He keeps no calendar, has no weeks or months or years. No Eskimo woman knows her age.

Although the Eskimo is deeply religious, he would never think of praying to God for help, because he holds that it is not necessary; God is his friend. His only prayers are to evil spirits, begging them to let him alone. He is sure of a future life; to his mind no one with any sense would question it. Some day he will go to heaven, a place where it's warmer, and the hunting's good.

What will the Eskimo say when he listens to the radio? Something about spirits, you can be mighty sure; for the Eskimo's explanation of motion pictures, which Captain MacMillan introduced him to last year, was, in effect, that the white man had cleverly conjured up the spirits of people in distant lands and put them through their tricks! Doubtless he will say now that the white man has found out a way to make those "spirits" talk and sing!

#### FOURTEEN MONTHS—OR FOUR YEARS?

**H**OW many months shall we be privileged to entertain our guests in the Arctic and how long will they be able to send us instalments of life in the great white solitudes?

Fourteen months, if all goes well—but one never knows.

In the year 1913, for instance, Captain MacMillan headed an expedition to "Crocker Land," which Peary reported having seen on his successful dash to the Pole in 1908. Incidentally, Captain MacMillan, who up to that time had been a professor at Bowdoin College, his Alma Mater, accompanied Peary on his earlier expedition, being third in relief when the final dash was made. On this "Crocker Land" Expedition MacMillan journeyed 300



HAPPY LAUGHING AL-NING-WA OF THE SMITH SOUND TRIBE

Eskimos do not keep a calendar, and no Eskimo woman knows her age. But that is the least of Al-ning-wa's worries

miles across a field of solid ice to a point 100 miles beyond the supposed location of "Crocker Land." It was nowhere to be seen. He then turned back and ascended the exact elevation from which Commander Peary had sighted "Crocker Land," and there, at a distance of 100 miles, he beheld this imaginary country—*rugged hills and wooded stretches, a perpetual and permanent mirage!*

In 1913, as I said, Captain MacMillan set out on this expedition to be gone only fourteen months. Four years later the ice of the Arctic gave up a ship, and a band of weary explorers made their way back to "civilization," there to learn for the first time that practically the entire world was at war!

Great changes have come about since then. Radio may not have made the whole world kin—but at least it has placed its people all on speaking terms.

War smolders, and at present writing, the only terrible thing that impends is another presidential contest. This time, however, the men of the *Bowdoin*—happily enough—will not



IF AN ESKIMO BABY LIVES FIVE DAYS, HE IS GENERALLY GOOD FOR SIXTY YEARS

This most northern Eskimo boy in the world is taking a sun bath twelve degrees from the North Pole on the northern shores of Greenland

be kept in darkness. For better or worse, they shall have the news—and no man quicker than they! Thus, betwixt wars and rumors of wars, these men up North shall have full opportunity to size this old world up—and who shall say

that they may not indeed *prefer* to stay four years and perchance find out the answer to that question the Eskimo is always asking: "*Why do you and all the other white people like it better to live so far from our home?*"

## A Dry-Cell Tube Loop Set for Local Reception

By ALEX V. POLSON, E. E.

**T**HE receiving set here described is one which was built after a few weeks' experimenting with loop aerial sets, and it is primarily designed for reception from broadcasting stations that are not over a hundred miles away.

This set has operated satisfactorily, signals being clear and loud, while it was being carried around the house. As the detector tube used is a  $1\frac{1}{2}$ -volt tube, the set may be made very compact and may therefore be used as a portable outfit which will prove convenient where a ground connection cannot easily be made.

A feature of this set that is a little unusual is the *double loop aerial*, one loop being used as a regular loop aerial and the other being used as a tickler coil. The diagonals for the frame consist of two pieces of dry wood  $2\frac{1}{2} \times \frac{1}{2} \times 18$  inches, mortised at the centre and mounted as shown in the accompanying diagram (Fig. 1). Two sets of binding posts are mounted on the face of the frame as shown. The loop aerial proper consists of 15 turns of No. 20 D. C. C. magnet wire spaced one eighth of an inch apart and held in place by saw cuts made in the ends of the diagonals. The ends of the wire should



be connected to two of the binding posts. The tickler loop consists of 14 turns of No. 20 D. C. C. magnet wire spaced one quarter of an inch apart and held in place on the face of the frame by small brads. The ends of this coil are connected to the other two binding posts.

The inductance coil shown consists of 60 turns of No. 24 D. C. C. magnet wire wound on a cardboard tube 4 inches in diameter and  $3\frac{1}{2}$  inches long. Taps are taken off at every tenth turn. The variable condenser is an 11- or 23-plate one, with a vernier for best results. In mounting the condenser and inductance it was found that considerable space could be saved by putting the condenser inside the inductance tube. The rheostat should preferably be one with a vernier, as very close regulation of the filament temperature is advisable with the peanut or other  $1\frac{1}{2}$ -volt tubes. The grid condenser may be of either .0005 or .00025 mfd. and should be used in conjunction with a variable grid leak. The phone condenser may have a capacity of .001 or .002 mfd. The panel used by the writer is of mahogany, one quarter of an inch thick, but any one of the several radio panel materials may be used satisfactorily. Tin foil was stuck on the rear of the

panel and connected to the negative side of the B battery to cut out body capacity effects. Care should be taken that the tin foil does not touch any of the metallic parts such as binding posts or contact points as

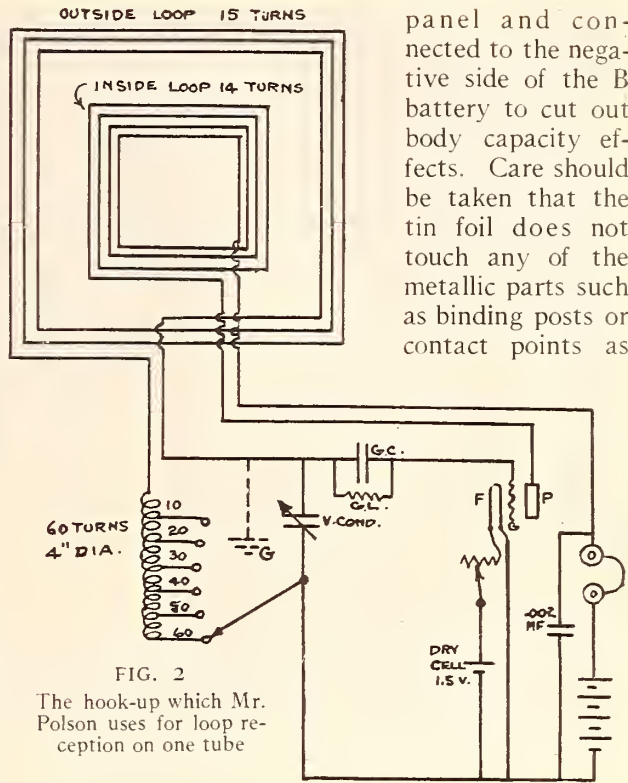

FIG. 2  
The hook-up which Mr. Polson uses for loop reception on one tube

this may short circuit some of the apparatus. About eighteen or twenty will probably be the best B battery voltage to use.

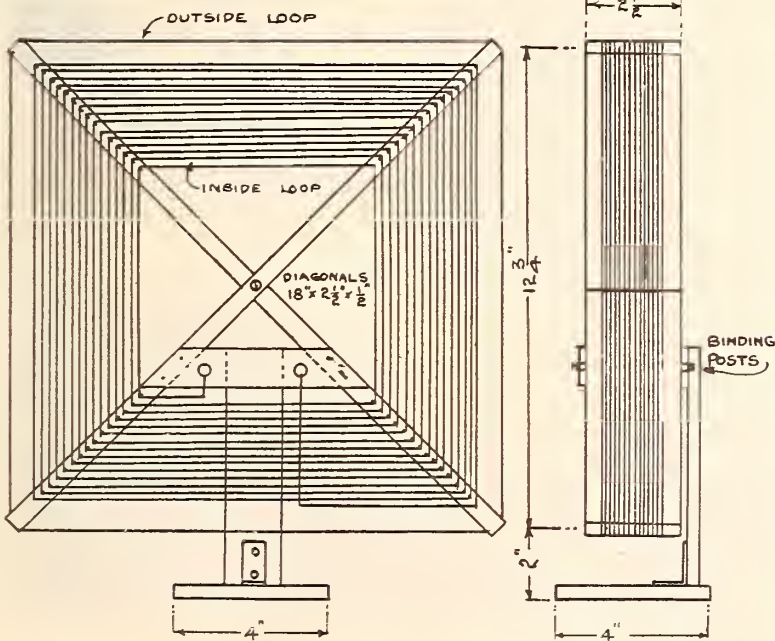
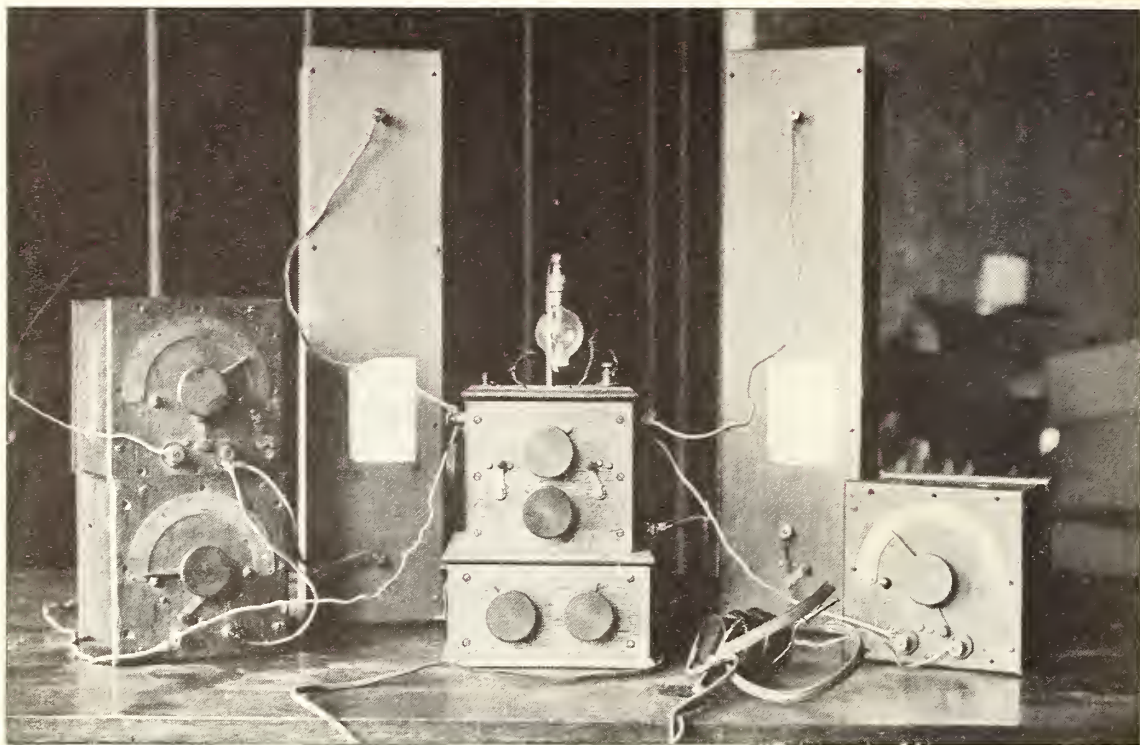

FIG. 1

To operate the set, it is only necessary to point the loop so that its edge points toward the broadcasting station, turn on the filament, set the inductance switch to about 50 turns and vary the condenser until signals or a whistling sound is heard. Further adjustment of the rheostat and vernier condenser will then clear up and bring the signals in at their best. If it is impossible to get signals at all, the tickler should be reversed at the binding posts, as the tickler must be connected in the proper direction. If the ground connection shown by the dotted lines (Fig. 2.) is used in addition to the loop, signals will be much improved in intensity.



**JUNK WORTH A MILLION!**

With this very equipment, Edwin H. Armstrong discovered regeneration—the receiving system that revolutionized radio reception and made the inventor famous



## Eighteen Years of Amateur Radio



The Days When Hams Could Send on Any Wave. The “Junior Wireless Club Limited,” Which, in 1911, Became the “Radio Club of America.” Pioneer Experiments and Inventions. Early Measures to Reduce Interference. Recent Activities Sponsored by the Radio Club

By **GEORGE E. BURGHARD**

President of the Radio Club of America

It is with pleasure that we present this paper on amateur radio, prepared by one of the foremost American amateurs. This paper has just been read before the Radio Club of America at the close of a successful season of lectures.

We feel sure that the readers of **RADIO BROADCAST** will be glad to learn that the Radio Club of America has chosen our magazine for the exclusive publication of its papers, and we wish to express our appreciation of the compliment paid us.

Such solons as Professor M. I. Pupin, Professor L. A. Hazeltine, Professor J. H. Morecroft, E. H. Armstrong, W. C. White and many others, present to this Club papers of importance, in which we feel sure that you will find great interest.

The second of these papers, which will appear in our September issue, deals with the latest of all the vacuum tubes—those employing thoriated filaments—and is the work of Mr. W. C. White, of the General Electric Company, who helped develop the tubes.—**THE EDITOR.**



**I**N AN attempt to create a precedent which it is earnestly hoped will be followed as long as the Radio Club of America exists, this paper is presented as the first of a series of papers by the Chief Executive, describing the activities of the organization and its members during the last twelve months. As this is the first of the series, however, it may be well to review the achievements of the Club from the time of its inception, and even the work of its members before the idea of organization had materialized. In this way it is possible to gain a good idea of the beginnings of amateur radio as well as the early strivings of the art in general, since the Club numbers among its members many of the radio pioneers.

It is the earnest hope of the writer that the aforementioned precedent will be followed closely and that each succeeding President of the Club will prepare and read a paper covering its accomplishments during his period of office. Thus, an accurate record of Radio Progress can be maintained and should prove of considerable interest and value both to the present and future radio generations.

The early days of radio were indeed days of darkness and pioneering—days when traffic had to be handled with a coherer and a straight gap spark transmitter. This meant that the personnel was really the most important factor, and operators were developed who could copy coherent messages under conditions when the average mortal could distinguish nothing but crashes and noises. These men, who learned their lessons in a very hard school, learned them well and are in many cases the prime factors in radio to-day.

At the same time that the commercial companies were making their initial stand, the fascination of sending messages through space without wires began to take hold of the younger generation, and we have the beginning of amateur radio, about 1905. Of course, there had been private experimenters prior to this, but the real radio amateur had his beginning in the end of 1904 to 1905. Small boys began to inveigle their parents into giving them money with which to buy wire and other material to build their own sets in imitation of those used by the commercial companies. Their efforts were gallant indeed, for there were no books



BACK IN 1910, WHEN THE WRITER WAS AN ARDENT FAN  
George Burghard operating one of his first transmitters, located at 1 East 93rd Street, New York City





## THE RECEIVER

AT 2 PM

Not the time of day but the call letters of the station owned by John Grinan and Adolph Faraon. Amplifiers were almost unknown when this station, in New York, heard the "Coast," and the two tubes were both used as detectors, with individual controls

to guide them. But the results proved successful in some cases, where the frequency of the transmitter happened by chance to be within the range of the receiver, or someone had gained expert knowledge from the operators at Manhattan Beach or the Waldorf Astoria where the main commercial land stations were located. With the crude apparatus and the embryo knowledge available, it was really remarkable that those boys could communicate at all, but almost any night one could hear messages being exchanged between stations in New York City covering distances of approximately a mile or two.

At that time there were perhaps a handful of these amateurs in New York City, but they grew rapidly in numbers and by 1909 they had already organized into the "Junior Wireless Club Limited." This organization, which was really the first of its kind, held regular monthly meetings at the Hotel Ansonia where the President, W. E. D. Stokes, Jr., was living at that time. The original membership consisted of eleven men who, it may be said, were the founders and charter members of the Radio Club of America: W. E. D. Stokes, Jr., George Eltz, Jr., Faitoute Munn, Ernest Amy, Frank King, Graham Lowe, Frank Whitehouse, Lyman Butler, and George E. Burghard. These young boys were the leaders of amateur radio at that time and soon drew all the live operators into their organization.

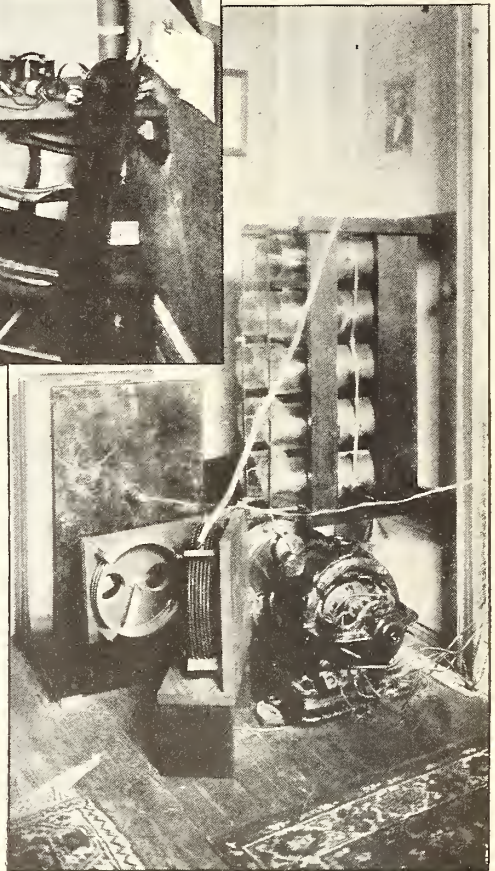

## 2 PM'S TRANSMITTER

This was the first amateur station to transmit across the continent

In 1910, under the auspices of the Radio Club, the father of all radio call-books was born. It consisted of a single mimeographed sheet with some thirty-odd names. Later this was increased to two sheets, then four blue printed sheets, and so on until the task became too ponderous and had to be undertaken by real publishers.



The following list is copied from the original typewritten sheet. (The question marks indicate names or addresses that could not be made out):

BB Max Bamberger, 16 W. 70th St.  
 GX Harlow Hardinge, 331 W. 101st St.  
 9 ? Melly, 328 W. 96th St.  
 HB Doctor Besser, SE Cor. Bdwy & 144th St.  
 DR Dr. W. G. Hudson, 312 W. 100th St.  
 VD Randolph Runyon, Yonkers, N. Y.  
 C George Cannon, Mount Vernon  
 SK G. Skinner, Mount Vernon  
 GE George Eltz, ? W. 47th St.  
 WR W. Russell, 242 W. 104th St.  
 VN Irving Vermilya, Mount Vernon  
 BB Louis Schulman, ? W. 106th St.  
 K9 Francis C. Knochel, ? W. 159th St.  
 YN G. Popper, 763 Beck St., Bronx  
 PC Percy Corwing, 5 West 107th St.  
 DG Harry Johnson, Patterson, N. J.  
 IY Fred Tracy, 4 W. 129th St.  
 BF Brace Fidler, ? W. 129th St.  
 RG Alfred Roebing, Far Rockaway  
 UH Ernest Hubner, 1657 First Ave.  
 WL Walter Lemon, 94th St. & Bdwy.  
 GW G. Bartlett, 8 W. 108th St.  
 EA Ernest Amy, 48 W. 70th St.  
 DX Elmer Ayers, 235 W. 103rd St.  
 SG Vincent Lamarche, 70 W. 46th St.  
 CH John Myers, 315 W. 40th St.  
 GH Doctor Goldhorn, Mount Vernon  
 KH K. Harries (2)  
 QW C. D. Winslow, 1985 Amsterdam Ave.  
 PX P. H. Boucheron, 303 E. 48th St.  
 JB Louis Bahr, 1929 Amsterdam Ave.  
 JF John Farrington, 467 W. 159th St.  
 TR George Post, 292 Riverside Drive  
 CP Clarence Pfeiffer, Ridgewood, N. Y.  
 AH Arthur Herbert, 138 W. 123rd St.  
 CS Charles Schaffer, 459 E. 147th St.  
 YP Fred Parsons, 764 Beck St., Bronx  
 BO Massey Wireless Co., 170th St. & Jerome Ave.  
 FK Frank King, 326 West 107th St.

In 1911 the membership had increased considerably, and the name was changed to The Radio Club of America, which is the name it bears to-day. By this time books and other literature on various radio topics began to appear, so that the knowledge of the Club members was greatly increased and papers were delivered at their monthly meetings, which were held at the home of Frank King, who was elected first President of the new organization. The first papers consisted of short talks describing the various stations operated by the members, and various they were indeed. It is almost useless to attempt descriptions, but perhaps the accompanying photographs will serve to give an idea of the types of apparatus used and the great handicap under which communication was maintained in those days when it was considered a great event to work Yonkers from New York City direct. But still, even this was a great advance over the old coherer days. Now there were

crystal detectors, microphone detectors, and even electrolytic detectors. Boys were busily engaged in breaking up chunks of rock in an attempt to find a good piece of carborundum, copper pyrites, or zincite, or groveling on hands and knees diligently searching the floor for the missing piece of Wollaston wire which was always diminutive and hard to find. These new detectors together with the advance in knowledge enabled the amateur operator to establish quite reliable communication within the city limits and occasionally a superhuman feat such as working Yonkers, a distance of about fifteen miles was accomplished, but for some unknown reason it was impossible to get any signal across to Brooklyn.

And yet the strivings of this handful of boys led to great things and great things were discussed at the meetings. No one thought of the far-reaching possibilities of the Hudson coated filament at the time when Dr. Hudson delivered his paper describing this very useful invention over the pool table at Frank King's house in 1913, nor were the stupendous results of the regenerative circuit in any way apparent at the time E. H. Armstrong told us all about it at one of the meetings in 1915. Who could have dreamed of the extent to which radio telephony would grow when, in 1911, George Eltz and Frank King constructed and operated an arc telephone transmitter at 107th Street and actually played music for the benefit of the fleet in the Hudson River when the alcohol didn't explode in the arc chamber and cause a violent break-down without any time for an apologetic "one moment, please." This may be said to constitute the first real broadcasting station ever operated with any degree of success.

By this time the three-electrode vacuum tube had appeared on the scene. Audions they were called, and cost \$5.00 a piece, but every amateur had to have one. So down to the Metropolitan Tower he would go, up to the DeForest Radio Company's laboratory, leave his five and go home with his most precious possession. Of course the number of identical new circuits and inventions developed by these boys was great, but nevertheless communication was greatly benefited and messages could be sent and received over distances of approximately 50 miles, quite regularly. This marked a great advance in amateur radio.

During these early days, the activities of these amateur experimenters aroused con-

siderable interest, and it was not long before the Government began wondering what it could do to control these newcomers. The idea of restricting the free air had never occurred to any one before. The result was a bill introduced by Senator Depew in 1910, prohibiting amateur radio communication. The then members of the Junior Wireless Club quickly rallied, and a committee was sent to Washington to plead the cause of the amateur before Congress. The plan was successful and the bill was lost. In 1912 the Alexander Wireless Bill was introduced, which purported to do all that the Depew Bill had failed to accomplish and even more. The Club also took action on this bill, killed it in Committee, and later, through the concerted action of its members in the service after the Armistice, definitely settled the matter.

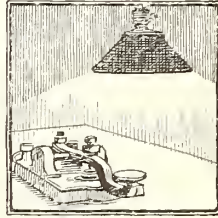

In 1912, one of the most illustrious members of the Radio Club, E. H. Armstrong, developed the feed-back circuit which has made possible the broadcasting of to-day. This, of course, did wonders for the amateur. All kinds of tuning coils and couplers were put into use, and sets were operated to the Nth degree of regeneration until finally real communication with the Western amateur stations was established and amateur radio came into its own.

This also opened another field to the amateur, namely transatlantic reception. Perhaps the first attempts at hearing the stations of Europe were made by Paul Godley, Harry Sadenwater, and Louis Pacent, who in 1914 strung an antenna from the Palisades on the Hudson River and with a specially constructed receiver listened patiently for what they had never heard before. Little did Godley think at that time that some years later he would be listening just as attentively, under different conditions, in a tent in Scotland, for the signals of his brother amateurs in America.

In those days, of course, there were no licenses and no regulations for amateurs. Everyone used whatever wavelength he happened to hit upon, and the great difficulty of getting a wave meter left that unknown in most cases. The only way to find out whether the set was in tune was by inserting a carbon filament lamp in series with the antenna and adjusting the helix [antenna tuning inductance] for maximum brilliancy. Some stations had aerials of as many as eight or ten wires, one to two

hundred feet long, and sparks gaps directly coupled. This, of course, could not continue, so the Radio Club welcomed the new license regulations and did a great deal toward assisting Radio Inspector Marriott and later Harry Sadenwater in clearing up the mess. In fact, the relationship of the Club with the Department of Commerce has always been most friendly. On one occasion the two organizations combined to track down an amateur station in Brooklyn with a loop mounted on an automobile. The boy had for no apparent reason been sending out distress calls, and after a whole night's searching the station was finally located and the culprit called to account.

This was going a long way toward the right system of cooperation, especially in those days when the notion of free air still prevailed and it was actually necessary for the operators of one commercial station to invite certain amateurs to go swimming at Coney Island so that the relief operators could handle their traffic without interference!

The Club soon outgrew its quarters at Frank King's home in 107th Street and it was not long before the attendance at meetings grew so large that it became necessary to use the large lecture halls of Columbia University for the monthly gatherings. As the art grew and radio knowledge was more readily obtainable, the character of the papers also changed. The small body of amateur operators gradually changed to a large scientific organization of recognized standing, before which the leading lights in the radio world were glad to deliver papers on their newest discoveries. But in spite of these changes the club idea and spirit of comradeship was never lost, and even to-day the Radio Club of America is as proud of its congenial club spirit as it is of its scientific standing.

In 1915 the Club installed and operated a transmitting and receiving station in the Hotel Ansonia where Admiral Fletcher had made his headquarters. The station operated by the Club members handled all of the Admiral's traffic with the fleet in the Hudson River. Several hundred messages were handled, and President Wilson himself sent a message from the *Mayflower* commending the good work. The Navy League also presented the Club with a banner in recognition of its services.





PROFESSOR PUPIN AND THE DELEGATION THAT VISITED IBCG AT GREENWICH, CONN.

The trip was made with a view to using this station for transatlantic work on short waves. Professor Pupin is seated in the centre of the group, with George Burghard at his right, and E. H. Armstrong at Burghard's right

A year later, amateur station 2PM which has gone down in history as one of the most famous of all amateur stations, owned and operated by John Grinan and Adolph Faraon, succeeded in breaking all records by sending the first transcontinental relay message from New York to California. This affair was not prearranged but was accomplished during the ordinary transmission periods and the answer was received back in New York in one hour and forty minutes from the time of transmission. Several weeks later the same station and the same operators succeeded in getting signals to California, a distance of some 2,500 miles overland, a feat which had heretofore been deemed impossible with an input of one kilowatt on amateur wavelengths.

Activities had to be suspended for the next few years, due to the fact that all the members of age enlisted in one branch of the service or another. The war records, which have been chronicled elsewhere, make too lengthy a

proposition for this paper. It suffices to say that practically all were officers in radio capacities and in charge of important operations, such as radio aircraft, radio schools, laboratories, field service, etc. Notably, E. H. Armstrong, with the armies in France, invented the super-heterodyne receiver which aided greatly in establishing successful radio communication at the front.

After the Armistice was signed and things began to assume a normal appearance, Club activities were resumed and the first event was a get-together dinner, held at the Hotel Ansonia, in honor of E. H. Armstrong upon his return from France. Many prominent men were among those present and due homage was paid him for his great work with the Expeditionary Forces.

In 1919, a successful flight was made by the Navy Department from Halifax to the Azores, in which radio played an important part. Three planes were used and



of course radio was a very important part of the equipment and the operators had to be of sterling worth. Lieutenant Harry Sadenwater, a Radio Club member, was chosen to operate the set on the NC 1. Unfortunately, this ship was forced to the water within twenty miles of the Azores and it was due to the valiant efforts of Lieutenant Sadenwater that the storm-tossed crew were finally rescued by a destroyer which responded to his calls after some fifteen hours of gruelling work.

When, in 1921, the American Radio Relay League instituted its amateur transatlantic tests, the Radio Club of America built a special continuous-wave transmitting station at Greenwich, Conn. and succeeded in winning the prize offered by Mr. Burnham, of England, for the best station in the test. This station not only succeeded in transmitting audible signals to Paul Godley, also a member of this club, in Scotland, but was heard in Germany, Italy, and France. It also broke all records by sending a complete 12-word message to Scotland and later sent three complete messages direct to Avalon, Catalina Islands, off the coast of

California. These feats aroused such interest in view of the low power and short wavelength used (i. e., 1 K. W., 215 meters), that such prominent men as Professor M. I. Pupin of Columbia University and David Sarnoff, General Manager of the Radio Corporation, went to Greenwich to visit the station.

By this time the number of amateur stations had increased to a tremendous extent, and with broadcasting just about beginning, communication was becoming almost impossible. The Radio Club investigated the situation and found that most of the interference was caused by spark and interrupted continuous wave transmitters. It therefore undertook a vigorous campaign of advice and suggestion, through papers presented before the membership, to educate the amateur in the whys and wherefores of pure continuous-wave transmission and its many advantages over the older forms. The campaign proved successful and is still in progress.

It was at one of these meetings in 1922 that E. H. Armstrong startled the radio fraternity by producing a sufficient volume of music

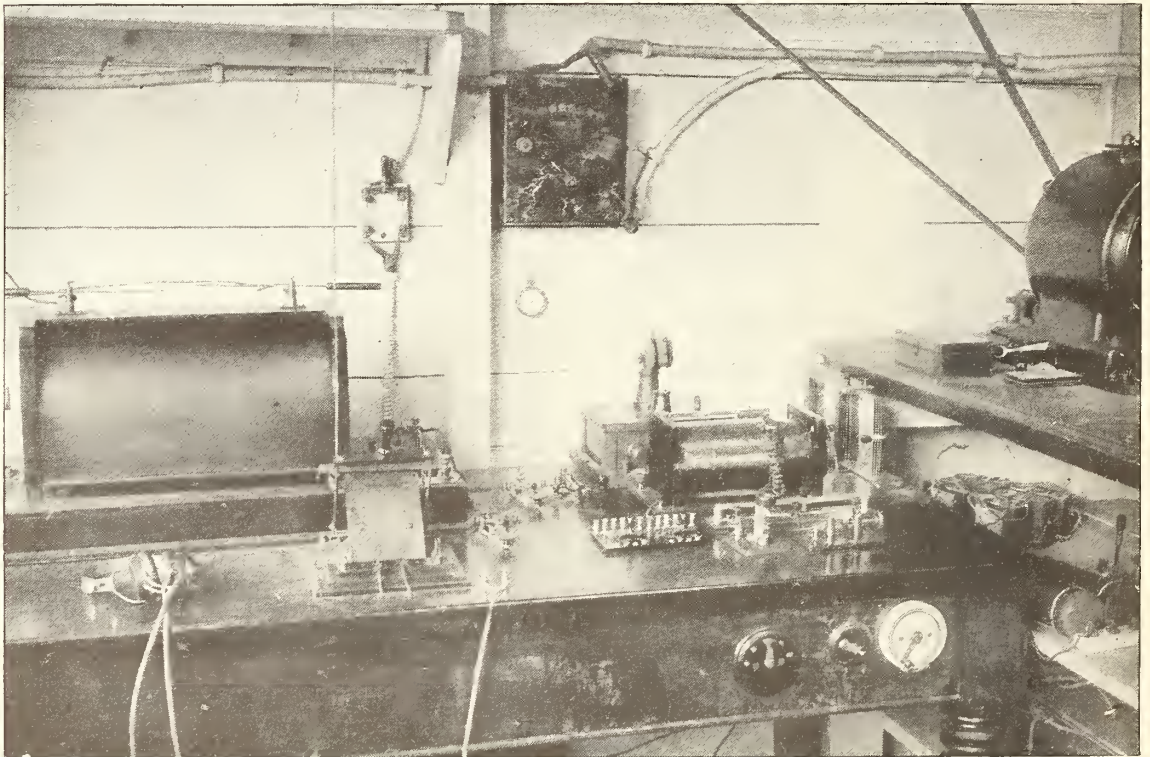

THIS IS FRANK KING'S STATION, FK, NOW NOTHING BUT A MEMORY OF PAST GLORY

Old-timers will recognize several antiques, including a variable condenser, loose coupler, crystal and electrolytic detectors, and that king of QRM—the 10-inch spark coil



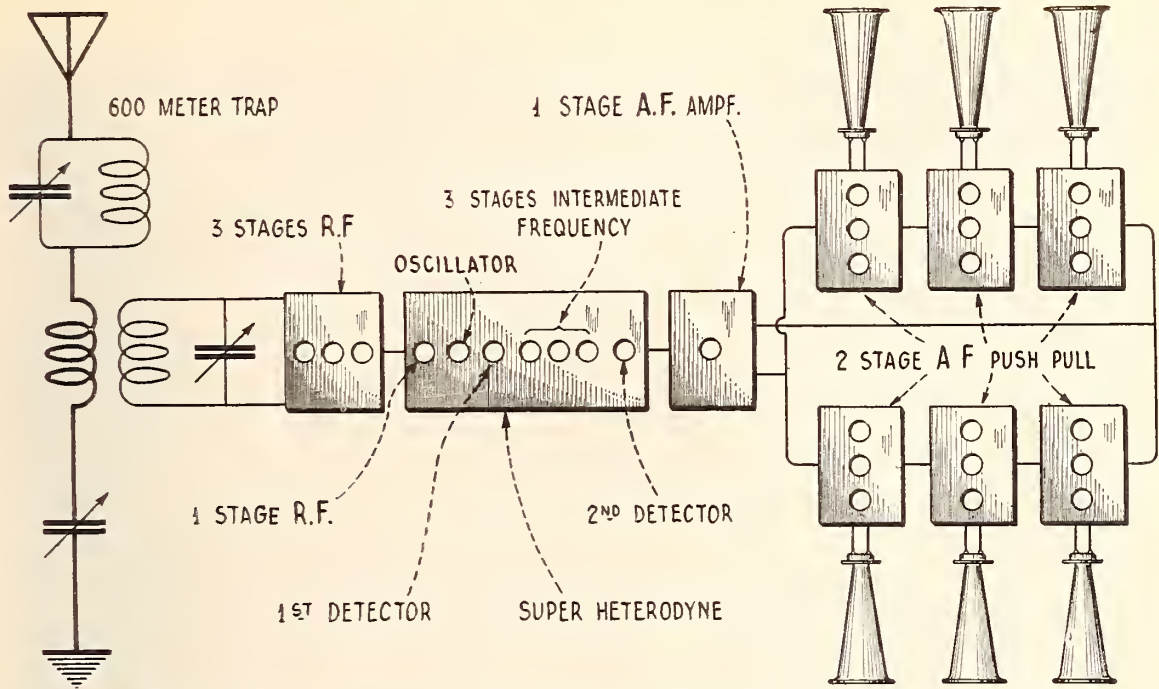

SCHEMATIC DIAGRAM OF THE LOUD SPEAKER SYSTEM USED AT GRAND CENTRAL PALACE

to fill the large lecture hall, using his newly invented super-regenerative circuit, a loop aerial and only one Western Electric J Tube. This performance, of course, had never been equalled, and when it is considered that the signals were coming from station WJZ, at Newark, N. J., and that the receiving set was located in a steel building with a copper roof at Columbia University, it was certainly an epoch-making event.

In December 1922, The Radio Exposition Company held a large Radio Show at the Grand Central Palace, New York. As everyone knows, if all the exhibitors at a Radio Show are permitted to receive broadcast programs at the same time, chaos would result due to heterodyning between the receivers themselves. In order to avoid this difficulty, the exposition directors decided to permit only one concern to do all the receiving. This, of course, was an unhappy thought since there was no way of deciding which company this should be, without causing vigorous protest from the other exhibitors. Finally it was decided to choose a non-commercial organization. The lot fell to the Radio Club of America. A special committee was appointed and the work begun. Tests were made a week prior to the opening of the

show with various types of antennas and finally it was found that even a loop would pick up too much of the noises resulting from commutator sparking, circuit breakers, and electric locomotive shoes, from the power houses in the vicinity and the New York Central tracks directly beneath, so that a single wire about fifteen feet in length had to be used. The problem proved to be twofold and a great deal more ponderous than was at first anticipated. First there was the matter of doing away with extraneous noises so as to deliver pure radio signals to the power amplifiers and secondly a physical problem of placing the loud-speaking horns so that there would be no re-echoes or dead spots. The first was solved after much experimentation by the small antenna, a 600-meter frequency trap, and a super-heterodyne receiver. The acoustic problem, however, offered stubborn resistance. Six loud speaker units with four-foot straight horns were obtained, and the question was how to place them so that the sound would fill the entire Grand Central Palace exhibition hall. At first, they were hung radially in a cluster from the ceiling in the centre of the floor space. This proved unsuccessful since many re-echoes were produced from the side walls and dead spots resulted from large columns. Finally,

after trying several other positions, it was decided to place the horns on the balcony directly in front of the specially constructed booth which housed the receiving and amplifying apparatus. It is interesting to note that all the horns had to be placed together because any separation by placing horns at various points about the hall produced out of phase relationship and distortion. As it was, only five horns could be used, since the sixth faced a wall and produced a decided re-echo which interfered with the speech to a marked degree.

The receiving and amplifying apparatus used, consisted of the small antenna described before, a frequency trap consisting of a coil and variable condenser, a tuned circuit, three stages of radio-frequency amplification, a super-heterodyne receiver with one initial stage of radio-frequency amplification, and three stages of intermediate-frequency amplification, and the usual oscillator and two detector tubes; one stage of audio-frequency amplification and then six two-stage audio-frequency amplifiers of the push-pull type, connected in series parallel, each amplifier feeding one horn, the sixth horn being in the booth and acting as a pilot for the operators. Some twenty-nine tubes were used in all and each horn may be said to have had fourteen tubes connected to it. Of course, the drain on the batteries was great, but four 250-ampere-hour 6-volt storage batteries supplied the filaments without much trouble, while 95 dry cells connected in series successfully handled the plate supply. The diagram on page 297 gives an idea of the general layout and circuits.

This system proved very successful and in spite of many sceptical opinions at the outset, sufficient volume was produced to fill the hall amply, and on the last night, the signals from WEAF were reproduced with such intensity that several of the audience on the main floor were seen to hold their hats in humorous indication of their approval.

In 1922, when Secretary Hoover found it necessary to call a meeting of the radio interests before a special committee of his choosing, the Radio Club was represented on the Committee by E. H. Armstrong. Thus the Club again as of old took an active part in the regulation of radio by Congress. This special committee reported direct to Congress

on its findings, and did much to help frame the present regulations.

This brings the tale of the activities of the Radio Club up to the present day. It is hoped that they may continue along the same lines for many years to come and that those policies which have been followed in the past and the ideals for which the Club stands will never be forgotten. The Radio Club of America was organized to propagate the art of radio telegraphy and telephony in all its branches, and

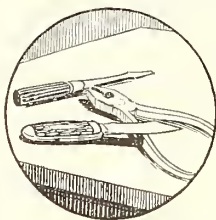

true to this ideal it has always lent its aid to the best of its ability to all phases of the art. It originated as an amateur organization with a scientific purpose. It fought for the continued existence of the amateur and helped to educate him. It lent a helping hand to commercial radio, by

research and coöperation wherever it could. It gave all it had to the Government when it was in dire need of radio personnel, and, finally, when that new element in radio cropped up—the broadcast listener—it gave him much needed assistance. This organization belongs to no one branch of the radio art but to all branches and therefore its duty at present must necessarily be one of education. Through the medium of its papers and discussions as well as the individual efforts of its members, it must endeavor to terminate the disastrous conflict which has sprung up between the original radio amateur or traffic amateur and the broadcast listener. Both classes must be trained and assisted to become mutually beneficial to one another. The traffic man must be shown how to construct his transmitter so as to create minimum interference, and the broadcast listener how to operate his receiver at the point of maximum selectivity. Neither one nor the other can or should be permitted to die out, for each has his own particular value. The broadcast listener class is composed of the general public whose pleasure and comfort must not be interfered with at any cost, while the splendid services of the traffic amateurs in the World War will never be forgotten and surely entitle them to an everlasting right of existence. But, unless these two warring factions, can be educated to coöperate and aid one another, one of the two is doomed; and this task of education for the good of the radio art must now be the important work of the Radio Club of America as well as all other radio clubs throughout the United States.





BROADCASTING A NIGHT SESSION OF A KANSAS CITY COURT  
A part of one of Mayor Cromwell's "civic radio nights." Judge Michael J. Kilroy of the North Side Court is at the right of the microphone

## "Selling" the Public on Better City Government

How Mayor Cromwell's Civic Radio Night Programs Bring Sessions of the Municipal Court Into the Homes of Kansas City Residents

By J. L. SIMPSON

**C**OULD the average business or professional man of Kansas City, or any other full-grown city in the United States, if suddenly called upon, take over the job of mayor of the city? Even the business man who regards his job as tedious or difficult might be pardoned for regarding such a step as jumping from the frying pan into the fire, especially with the horde of voters who "put him over" sitting back in an attitude of critical observation, waiting for the first sign that the new

chief executive of such city may fail to turn out a full day's work, with each and every twenty-four hours.

Frank H. Cromwell, who was overwhelmingly elected to preside over the "Heart of America" at the last municipal election, recently found himself in this precise predicament, and didn't exactly enjoy this sensation. He had specialized in the butter and egg business until his election about one year ago, and discovered very shortly that he knew much more about the intricacies of dealing in those commodities

than he might reasonably expect to know about his new job for some time to come. Commenting upon this startling discovery, he said:

"I wasn't Mayor long when I found out I'd have to learn a lot of things about the machinery of city government I'd never dreamed of. I was up against the proposition of learning a new business—for the operation of a city government is a business of the most intricate sort."

The first morning Mayor Cromwell sat in his new office, he made the discovery that he was boss of twenty-three city departments, each separate and distinct from the others, just as in any great corporation.

Each department, he found, had a certain duty to perform in giving service to the public, and must give satisfactory service to its "customers" very much in the same manner as a street car company, a water and light company, or the grocer or baker around the corner. And at the head of each of these departments he found a board, or an individual, in control.

To this successful butter and egg merchant—the new mayor of a city of 350,000 people—the job of rightly comprehending, to say nothing of intelligently directing this great municipal corporation, looked like a mighty big task. True, he was very familiar with the process of turning butter and eggs into dollars and cents—but this was different! However, like a true business man, he set about to learn this new executive job—city government. He made up his mind to discover "what made the watch tick" in the city hall, and especially to ascertain the source of the "wherewithal," and the close connection between the taxpayers' "outs" and Kansas City's "ins."

Then followed tedious hours, days, and weeks, while the Mayor, surrounded by instructors, departmental heads and the like, bent over wide tables and delved into great books—amazing arrays of tabulated reports and totals—striving to gather something beyond a mere superficial knowledge of how and where the city

obtained the funds which are the lubricant of city government, and, more important, how to direct the distribution of these millions of dollars.

After weeks of study along this line, bringing gradual enlightenment, he came to realize that his own ignorance of the functioning of the municipal government was as nothing compared with what the average voter knew of the conduct of his city's business.

Here was a real problem—and one of universal application. The merchant, to exist, reasoned the mayor, must sell his wares, and to sell

his wares he must advertise. The city, with a great stock of wares to sell, also should advertise. The voter—the ultimate consumer at the city store—must know what is on the counters and shelves. He must be informed of the "service" offered by his city.

The mayor pondered over this problem. How was he to "take the city government to the voter?" How was the voter "to be sold" on the proposition of operating his city government?

After compressing the problem into this understandable form, Mayor Cromwell compiled a list of prospective advertising mediums, jotting them down on a slip of paper.

"Printed publicity is good," he said "providing that a sufficient number of people will read it.

"Public meetings will draw only a negligible per cent. of the population. We might write letters, but that would entail great expense, and perhaps only a few persons would pay any attention to them."

On Mayor Cromwell's desk, as he thus pondered this question, lay a magazine. The cover design caught his attention. It was of a woman singing before a microphone, her voice being broadcasted by radio to thousands of listeners-in.

Suddenly Mayor Cromwell saw a "great light." "That's it!" he shouted. "I'll broadcast my lessons in city government to the voter. We'll say it with ether waves."

Mayor Cromwell likes to make his dreams

Said Mayor Frank H. Cromwell: "A year as Mayor of Kansas City has revealed to me that an astoundingly large number of our citizens are ignorant of the functions of the various city departments. Only a few persons find time to attend public meetings. I believe that radio offers a medium through which citizens of a municipality who have little or no opportunity to learn the details of municipal government, can inform themselves of the work of the various departments."



come true. Perhaps that is one reason why he made a success in the butter and egg business; or why he managed to win the race for mayor of Kansas City, while every newspaper in town was plugging for his opponent.

There followed immediately a conference with Emory J. Sweeney, president of the Sweeney Automotive and Electrical school, and owner of one of the most up-to-date broadcasting stations in the United States.

"We could broadcast civic radio night programs from your station," explained Mayor Cromwell to Mr. Sweeney, "and our big difficulty—that of finding a medium of maximum expression—would be solved."

Mr. Sweeney was interested in the mayor's plan. So a date was set for the first civic radio night. It was announced as "Hospital and Health Board Night," with Dr. E. H. Bullock, Kansas City health director, as principal speaker, and Mayor Cromwell as master of ceremonies.

Thousands of radio set owners, not only residents of Kansas City, but of surrounding communities, were surprised and pleased by the new type of program. Letters of commendation and telephone calls poured into the mayor's office, calling for "more along the same lines."

The feature of the second civic radio night was an address by John Pew, City Counselor. His address was aimed directly at voters and taxpayers, and he explained to them exactly "where the money goes" in keeping the wheels of the city government revolving at the necessary speed.

The third city official whose voice was broadcasted from station WHB was Charles Tucker, President of the Board of Public Welfare; he explained the operation of men's and women's reformatories, the municipal farm, and the scores of similar activities connected with his department.

Fred E. Turner, President of the Fire and Water Board, was the next speaker. He described the romance—and service—rendered

by the fire department, to each home in the city, and the courage and loyalty of the grizzled firemen, on a par with that of the soldier upon the battlefield.

Chas. S. Foreman, Assistant Engineer for the Water Department, told citizens and voters of the work in connection with furnishing a constant supply of fresh water for the city, while Ernest Tucker, Secretary of the City Plan Commission, outlined some of the commission's plans for the future betterment and growth of Kansas City.

But the big sensation and dramatic *coup* of Mayor Cromwell's civic radio night programs was entirely different from any of these, and one which almost took away the breath of a public accustomed to thrills of many kinds.

"We'll introduce something lively now," said the mayor to his assistants. "Why not permit the voters to listen-in on a session of one of our municipal courts—allow them to learn of the functioning of this department of our city government?"

Thus it happened, one night in March, radio fans in Kansas City and the Middle West were startled by this announcement:

"This is station WHB, broadcasting a session of the North Side Court, Michael J. Kilroy, presiding judge, as one of Mayor Cromwell's civic radio night programs. Just a minute, please."

A whirring drone followed—a minute of suspense, then—

"The next case," said the voice of the bailiff, "John Strong vs. the City; charged with drunkenness."

The arresting officer was called. John Strong could be heard walking up to the bench.

"John Strong, you are charged with drunkenness," came the voice of Judge Kilroy over the air. "Guilty or not guilty?"

"Guilty, your honor," replied the prisoner. "I'm always drunk—when I can get it!"

"One hundred dollars!" came the judge's reply.

And down through a regular docket of the



MAYOR FRANK CROMWELL  
Who is letting Kansas City listeners-  
in know how their city is run

court was broadcasted a slice of the comedy and tragedy found daily in the courts of Kansas City, yet beyond the imagination of many of the old-time residents of the town. It was a civic program with an appeal which was new to thousands of people wearing headsets that night in March.

Mayor Cromwell, to date, had played his trump card in educating the voter along the lines of better city government; had, in fact, taken the mysteries and practical workings of the various departments, and, more startling still, the courts themselves, right into the homes of tax-payers and voters, and had shown them the cost of operation and the results.

But what has been done is just a beginning. The mayor is convinced that this innovation is proving a valuable medicine in curing some of the city's chronic ills.

"We plan to broadcast a program each month," declared Mayor Cromwell, "and, to the best of my knowledge, this stunt is the first of its kind in the United States. I believe it is educational and will go a long way toward bringing the city government closer to

the people who pay to maintain it, and I believe further, judging from the interest and favorable comment, that the programs are appreciated."

Let those who doubt the tangible results achieved read some of the letters received relative to the civic radio night programs. Here is an excerpt from a letter written by one of the city's most successful insurance men:

I had the good fortune to listen in on the civic program broadcast by the Sweeney radio station last night and feel impelled to write and say that I appreciated it. It is of the greatest importance that our citizens, who are all stockholders in this, our great Kansas City corporation, should be informed fully as to all our civic affairs. . . . The program you have outlined will accomplish this most satisfactorily, in my opinion.

One could spend a whole day reading letters of this sort—sufficient proof that American people are willing to devote their time to a study of municipal government, especially when it is brought to them in as novel and appealing a manner as that conceived and executed by Mayor Cromwell.



BILLIE ORR, OF YOAKUM, TEXAS, REACHES OUT MORE THAN 1000 MILES WITH THIS SET

He saved up for a few simple parts, wound his inductance on a salt-box, salvaged some old telegraph wire for an aerial, used his dad's auto storage battery as the "A Batt.," and pulled in Detroit, Denver, and Atlanta. He has left plenty of room for the stage or so of amplification which he hopes to add



# Adventures in Radio

Perhaps no other branch of science enjoys the romance and the spirit of adventure ever present in radio. It matters not whether it is the radio telegraph or the radio telephone; both have equal advantages in this respect. Of course, radio telegraphy is the older of the two, and its exploits are more numerous; up to now, it has covered a wider field of endeavor, both on land and on sea.

Aside from its everyday uses, radio figures in a great many strange happenings which few devotees of broadcasting know about. Many of these are unique, not always possible or practicable to duplicate; some are accidents, others mere incidents, still others great adventures—adventures never to be forgotten and which stand out as red-letter days for the individuals concerned.

By adventures in radio we mean that which deviates radically from the commonplace. Radio has been responsible for many innovations. Some of them stand out as monuments of scientific achievement; others are ignominious exploits to which this high art has been subjected. All, nevertheless, are intensely interesting, breathing the very spirit of adventure and romance.

It will be the purpose of this department to report, from time to time, such radio adventures as have actually taken place, with real human beings as principals. The series will range over the entire world, including incidents in Sweden, Patagonia, and far-off Japan as well as in the United States.

We shall be glad to receive accounts of radio adventures from readers of the magazine, either their own experiences or authentic experiences of others.—THE EDITOR.

## When Messina was Destroyed

THE following paragraphs are from a letter received by RADIO BROADCAST from Mr. Stuart Lupton, now American Consul at Chefoo, China:

In the latter part of 1908 I was appointed Vice Consul at Messina, Italy, arriving at my post on December 22nd. At 5:20 A.M., December 28th, the city was almost totally destroyed by a disastrous earthquake. Owing to my having changed my lodgings on the 26th, I was fortunate enough to escape injury. As soon as I could I made my way to the Consulate, becoming more and more aware of the tremendous damage done as I walked along in rather a dazed condition. On my arrival, I found the place a heap of ruins which I had great difficulty in distinguishing. I realized that there was no chance of the Consul or his wife having escaped, and also that matters looked black for me. I knew very few people in the city, was practically penniless as I had not drawn any money after my arrival, and my knowledge of Italian consisted of less than a dozen words. I found all public services had stopped, cables were broken, land lines down and altogether things looked hopeless. That night I was a refugee on board a merchant vessel in the harbor. Seventy-eight people were packed in a small saloon, two or three cabins, and connecting passageways, with the rain coming down in sheets. The next morning we all had to go ashore again, as the steamer was to sail for Constantinople. Shortly afterward the British cruiser *Sutlej* came into port, stopped for about four hours, and left again with 1,100 wounded on board.

As the last boat was leaving for the ship, I had an inspiration. Seeing a piece of brown paper lying on the ground I picked up the cleanest portion and scribbled a message to the Captain of the *Sutlej*, asking if he would wireless a message to our Consul at Malta, to be relayed to the Department of State. A sailor said he would give it to the Captain, but did not know whether it could be sent or not. On the following Saturday, I found that the message had been sent, and that it was the first authentic news of the disaster received in the United States.

About this time I went on board the British Cruiser *Muierva* to call on the Captain, and while on board was told the following story. Captain Cagni, one of the best known and bravest officers of the Italian Navy at the time, had arrived in Messina in command of the battleship *Napoli*. On arrival, he paid several visits of ceremony, one of them being to Captain Wake, of the *Muierva*. He told Captain Wake that he had started from Naples to Gibraltar a day or two before the earthquake, and when nearing the latter port his wireless operator had intercepted a fragment of a message. All that was received was, "Messina destroyed." At that time there was a great deal of friction between Italy and Austria, so Cagni jumped to the conclusion that war had been declared and that an Austrian squadron had bombarded the city. Hence he turned and went full steam for Messina with the full intention of engaging any Austrian man of war he might meet. Fortunately, none was encountered, or the World War would have started ahead of time.

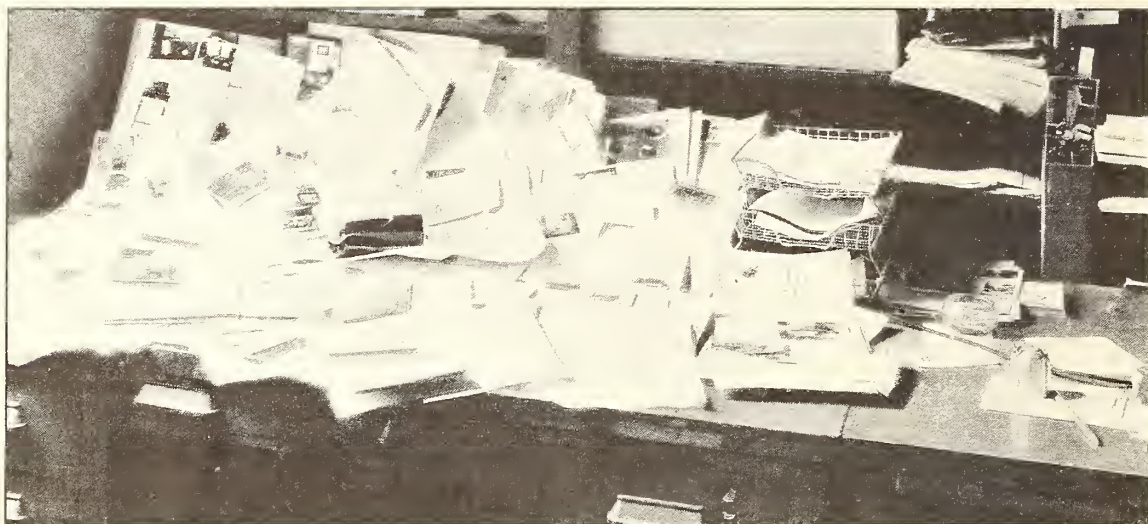

THE PRIZE-WINNING CONTRIBUTIONS ARE IN THIS LITTLE PILE  
Photo taken after the five-day blizzard which effectively tied up traffic on the Editor's desk

## Porto Rico Fan Wins "How Far?" Contest

Richard Bartholomew of Garrochales, P. R., Captures First Prize—a De Forest D-7 Reflex Loop Receiver—with Home-Made Three-Circuit Regenerative Receiver of Unique Design. Hears Many West Coast Stations Regularly. His Story

Before Mr. Bartholomew tells you about his very remarkable reception and his more remarkable receiver, there are a few words we want to say about our "How Far?" Contest.

As you may remember, our first contest—"How Far Have You Heard on a Single Tube?"—was a great success, so great, in fact, that we felt sure that one allowing any number of tubes and any kind of a receiver would be of even more interest to you. Accordingly, we announced the second contest, figuring that it would be successful from the firing of the first gun.

After three months of waiting for a publishable article for this contest, we decided that one of two things had occurred: either the interest in DX work had taken a sudden and universal slump or you were all sitting tight, figuring on coming up strong on the last lap and crossing the finish line a winner. If you could see our desk for an instant you would appreciate that the first of our suspicions was groundless.

We are snowed under. To be frank about it, we were entirely unprepared to handle the reams of material that arrived in time to be included in the contest. For the next week or so we are going to be up to our ears and no mistake, but it is going to be great fun, and we are sure that many of the articles will be suitable for publication.

And the articles themselves are not all that we have; one of the fellows went as far as making dictaphone records of the stations he heard. Unfortunately these records failed to stand the trip and arrived in a more or less pulverized condition. But with photos and diagrams and broadcasting maps and lists of stations and distances heard and descriptions of receivers and two or three sample home-made coils (all "world-beaters"), as well as a tremendous amount of "dope" on many "best" circuits—we have something to do.

As you may remember, in the rules for our contest the following paragraph appeared:

"In judging contributions, the quality and interest of photographs, text, and drawings, and the originality and general effectiveness of the apparatus described will have greater weight than the list of stations heard, although a long list of distant stations will distinctly help."

The contestant whose material measured up best has been chosen; but the short time remaining before we go to press, and the fact there are several contestants well toward the lead whose work is so nearly equal that a hasty decision might be an unjust one, make it impossible for us to announce the remaining three prize winners. They will therefore be announced in the next issue and several other articles deserving honorable mention will also be published if space permits.—THE EDITOR.



# A Neighbor at Three Thousand Miles

By RICHARD BARTHOLOMEW

(FIRST PRIZE)

**N**ATURALLY it has been of much interest to me to sit here in Porto Rico and listen to all parts of the United States,\* and up into Canada, and over to Cuba; but what appealed to me still more was to sit here in my shirt sleeves, with all doors and windows open, and listen to reports of five, six, or seven inches of snow and the thermometer ranging from freezing down to fifteen below zero. Then was when I could sit back and (if mean enough) give you the laugh; but if I listened in long enough I would again get back to a warm climate—California—although there the time was four hours later than in Garrochales.

My set is of the regenerative type, but due to the hook-up I use and a special method of shielding, there is *absolutely no body capacity* noticed, even while working on stations 3,525 miles away. In one instance, I adjusted the receiver to bring in KFI, Los

\*Mr. Bartholomew sent with his manuscript and photos a whole sheaf of letters which he had received from far-away broadcasting stations, verifying his records and commenting on his remarkable work. Here are excerpts from three of these letters:

"I wonder if you have received a notification that you are the winner of the Western Electric ear phones awarded to the person who heard the concert on October 28th, the farthest distance from Minneapolis? The announcement created a tremendous amount of interest in this city. On that evening we were heard by forty-six states in the Union, four provinces in Canada, in addition to you.  
Program Director, WLAG."

"We received your card reporting hearing our Radiophone and wish to thank you very much for same. We believe this reception to be a record for a 50-watt transmitter.  
WKY RADIO SHOP,  
Oklahoma City, Okla."

"You are our neighbor . . . you are certainly doing some good reception.  
HALE BROS., INC.,  
Radiophone Broadcasting Station KPO,  
San Francisco."

This last station is 3,500 miles from Porto Rico!

Angeles, and without changing the dials I heard about 20 different selections. This was on their opening night. I have heard them many times since.

The adjusting of this set is more than simple, for often I have tuned in eight stations only by turning the grid dial. At one time I had to be away from home a while, and so showed my

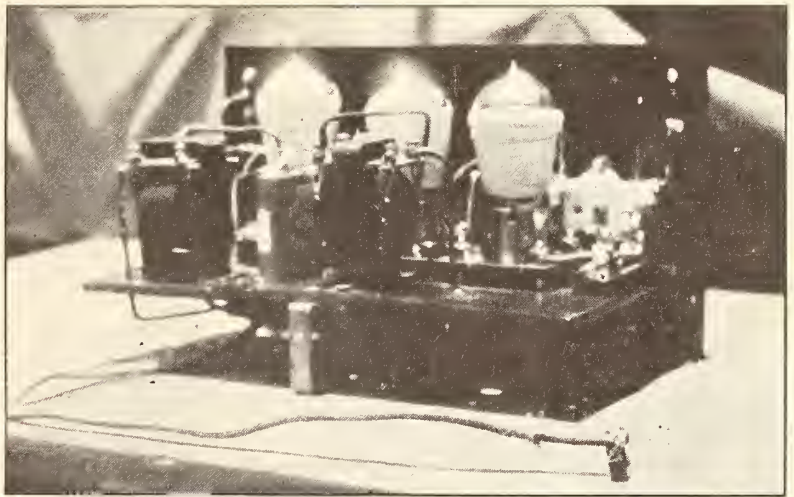

THE DETECTING AND AMPLIFYING UNIT SHOWING SHIELDED TUBES

wife how to connect the batteries, as she wanted to try the set. Upon returning, I found that she had had music every night, and the first night received eighteen selections, with names of pieces and artists, from WGY, 1,600 miles away.

Now we might as well roll up our sleeves and get right to the principal business of the day, which is, how you can make a receiver such as mine and how you can use it to best advantage.

## MATERIALS NEEDED FOR CONSTRUCTION

- 15 binding posts
- 18 switch points
- 3 switch levers
- 2 two-circuit jacks
- 1 single-circuit jack
- 1 Bradleystat
- 2 wire-bound rheostats (or Bradleystats)
- 1 potentiometer
- 1 grid leak (1 megohm)
- 1 grid condenser (.00025 mfd.)  
(1 double mounting if Radio Corp. materials are used!)
- 3 tube sockets

- 2 transformers audio. (Amertran or UV-712)
  - 1 .001 mica phone condenser
  - 1 panel, 7" x 18" for receiver (bakelite)
  - 1 panel, 7" x 12" for detector and amplifier (bakelite)
  - 1 piece of bakelite, rubber or wood, 7 x 11, for mounting transformers and sockets in detector unit
  - 2 vernier controls for variometers, friction type
  - 2 pieces of buss wire or No. 18 wire with spaghetti
  - 2 variometers having 66 turns on the rotor and 60 on the stator. Those wound with large wire and not using shafts for contacts are preferred
  - 1 variocoupler, same type as variometers, but with 30 turns on the rotor and about 48 on the stator, tapped so that it can be adjusted to every, or every other, turn
  - 1 piece of tubing of non-conductive material, dia. 4", length 1½"
  - ¼ lb. of No. 20 D. C. C. wire
  - 3 dials. One for each variometer and one for coupler
  - 1 4-volt flashlight battery
  - 1 piece of copper foil. 7" x 18" (shield)
- A few odd screws, brads and stove bolts  
 Enough ¼" lumber to make the two cabinets, one 7" x 8" x 18" and the other 7" x 8" x 12". Stain for same  
 Small bottle of shellac for painting loading coil
- 4 brass hinges (small) with screws
- Regular equipment:
- 1 6-volt A Battery (storage)
  - 2 22½ or 24 volt B battery either dry or storage
  - 1 pair of good phones
  - 1 detector tube, UV-200
  - 2 amplifying tubes, UV-201 or UV-201-A
  - Antenna and ground equipment.

#### CONSTRUCTION OF THE RECEIVER

ON the piece of tubing listed just above, make two small holes  $\frac{1}{8}$  in. from the edge and  $\frac{1}{4}$  in. apart. Through these two holes fasten the end of the No. 20 wire and make thirty turns, using the system of bank winding illustrated in Fig. 1. Make the first turn  $\frac{1}{8}$  in. from the edge and wind the wire in the same direction as the windings of the stator of the plate variometer. At thirty turns take off a

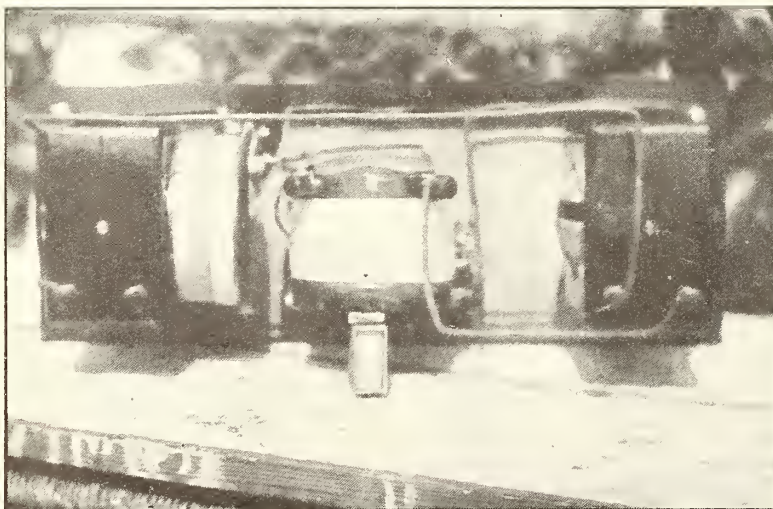

REAR VIEW OF THE RECEIVING UNIT

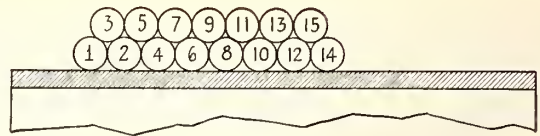

FIG. 1

Showing how the turns are made in bank-winding

tap, then wind thirty more and fasten the end as before. This makes a coil of 60 turns with a tap at 30. Now fasten this coil on the left hand side of the plate variometer, as shown in Fig. 2. (The coil is shown at the right of the variometer in Fig. 2, but this is because the view is from the rear). The writer did this with shellac, but any method will do. Place the taps so that they will be toward the panel.

Paste over the face of the panel a piece of white paper and on this draw out to size the dials, binding posts, switches, switch points, and verniers, always leaving enough space for the sides of the cabinet. Put on this drawing all holes to be made, to size, their centres, and whether to be counter-sunk or not.

Now try placing all the parts on the panel as indicated by the drawing you have made, including variometers and coupler, and see that they do not interfere one with the other. (The writer found that he could best place the variometers 13 inches apart, centre to centre, with the shaft  $3\frac{1}{2}$  inches from the top of the panel. The coupler shaft went half way between those of the variometers and 1 inch above them.) But as all variometers, etc., are different, you will have to experiment a bit to determine how to place and fasten them on the panel.

Using a centre punch, punch each hole and bore it. Glue the copper foil to the back of the panel and cut away around the holes for the shafts, all switches, switch points, and all binding posts *except the ground and filament posts*. Be sure that the foil is not closer than  $\frac{1}{16}$  inch to any of the parts other than the two binding posts mentioned. Solder the shield to these two posts.

Now you are ready to mount all the parts. Do so and wire them according to



the diagrams (Figs. 3, 4, and 5). Solder all contacts and run wires in straight lines making turns at right angles. Neat, painstaking work at this point will amply repay you for the longer time it takes.

CONSTRUCTION OF THE DETECTOR AND AMPLIFIER

THE panel of the amplifier unit is laid out and handled in the same way as that of the receiver, except that there is no need of a shield. Keep in mind that the binding posts have to correspond with those in the receiver, so should be placed at the same distances from the top of the panel.

The base supporting the sockets, transformers, etc. rests upon the jacks and is bolted to them. This means that one small hole has to be made in the detector and second-stage jacks, through which the base is made fast with two small bolts.

The Bradleystat is placed on the left hand side of the panel. Then comes the two wire-wound rheostats and last the potentiometer. These are evenly spaced across the panel and are on the middle or central line. The jacks are placed halfway between these about  $1\frac{1}{4}$  in. from the bottom of the panel. The five holes

made for each light are placed directly above the jacks; the top hole is 1 inch from the top of the panel.

The parts are now mounted on the panel and the base (of bakelite or wood) is put in place after cutting out a section to allow for the potentiometer and B battery leads. Now set the sockets, C battery, transformers, and grid (leak and condenser) mounting in the best possible positions. Try to keep the grid leads

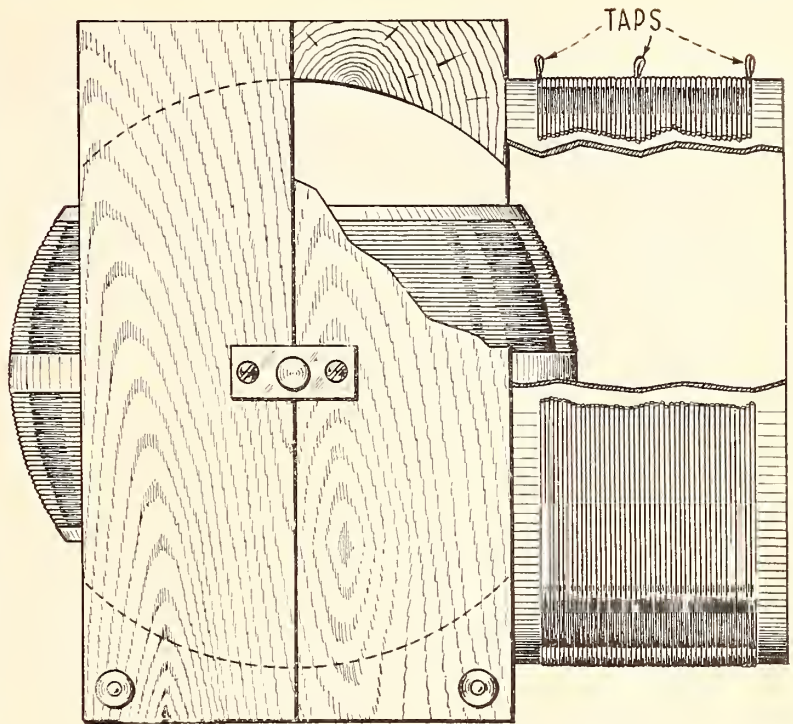

FIG. 2

Plate variometer and coil, rear view

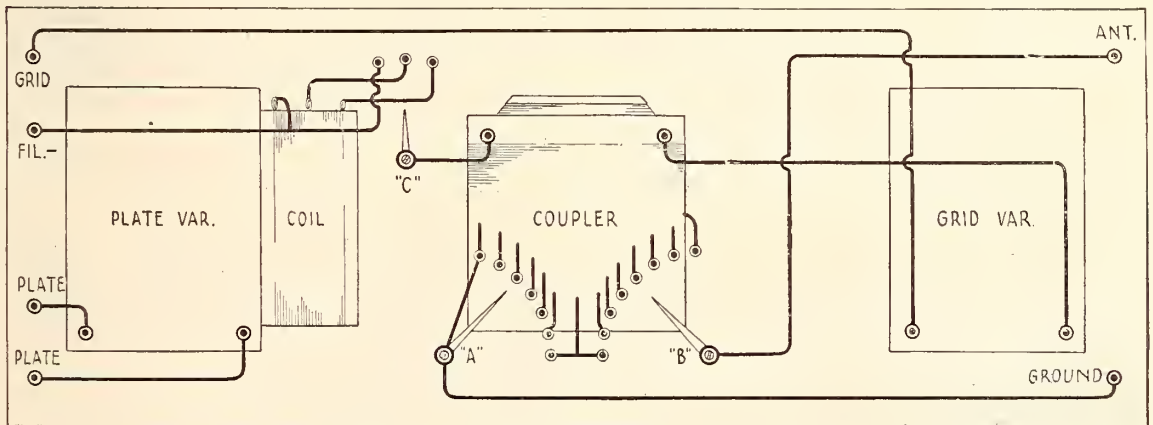

FIG. 3

Schematic wiring diagram of the receiver unit, rear view

as short as possible, the cores of the transformers at right angles to one another, and the lights directly back of the holes in the panels. When well placed, mark the position of each piece on the base, also mark holes for running the wires to the primaries of the transformers, plates of the tubes, and condenser shunted across from the plate to the filament (phone condenser, .001). Remove the base, bore all holes, mount the parts, and replace for wiring.

Don't overlook the negative binding post for the B battery, as this is placed on the back side of this base. A hole is made through the rear of the cabinet to admit the lead.

WIRING THE RECEIVER

**M**AKE all leads as short as you can, running them horizontally or vertically, with the turns forming sharp right angles.

Solder all connections possible, and be sure that all unions are good and clean.

The diagram, Fig. 3, is that of the rear view of the receiver. Note posts "Fil-" and "Ground"; they are the ones that should be soldered to the shield. The ground wire goes to the fine taps at switch marked A, and the switch and end of coil are connected as in the circuit diagram (Fig. 5). The aerial goes to

the coarse taps or switch B (Fig. 3). Switch C is use for the loading coil.

The taps at A are taken every turn.

The taps at B are taken every six turns.

WIRING THE DETECTOR AND AMPLIFIER

**M**AKE all the leads as short as possible, especially the grid leads; also be careful that the grid and plate leads do not run parallel for any great distance.

The binding post for the negative of the B battery is placed on the base supporting the sockets, etc., and a hole is made in the cabinet back to admit the lead.

All tubes are wound with No. 20 wire. This can be done in any way as long as the wire makes a perfect shield as high up on the tube as possible, leaving the end of the tube uncovered (see photo showing tubes wound with wire). The writer fastened the wire in place with small pieces of tape. Both ends of the wire are fastened together and grounded to the negative of the filament, or negative of the A battery.

Solder all connections, and when everything is ready try lighting the tubes before you connect up the B battery. It may save blowing out a tube.

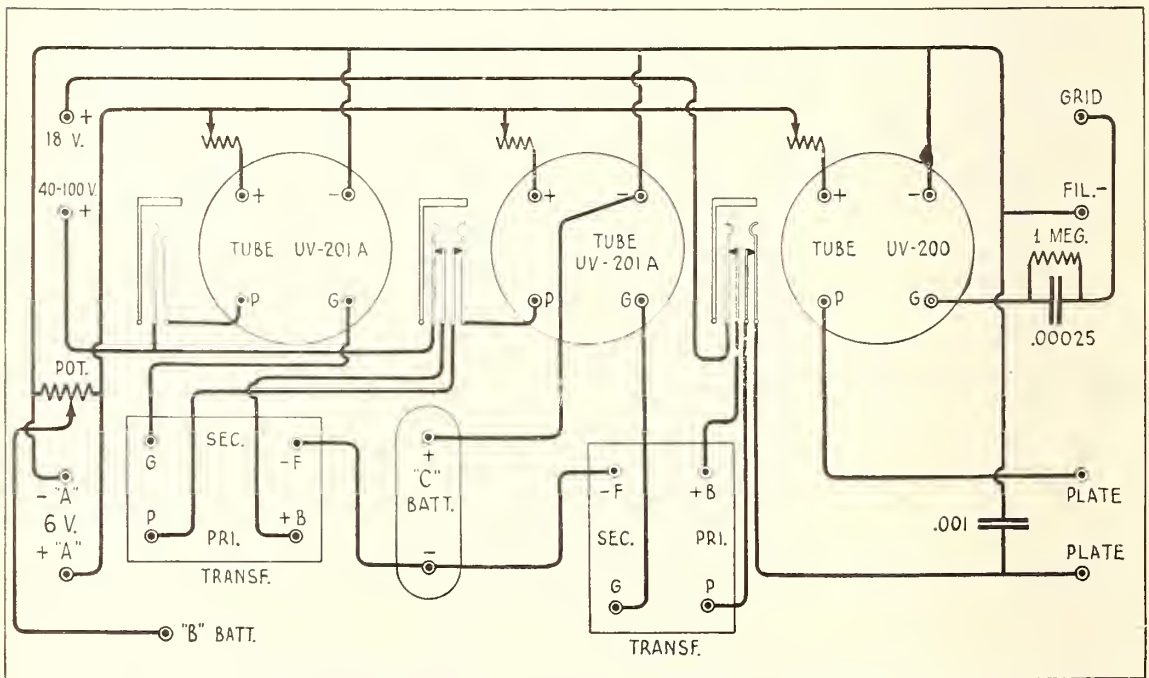

FIG. 4

Schematic wiring diagram of detector and amplifier unit, rear view





find that the station will drop in clearly or drop out. If it comes in clearly, O.K., but if it drops out, you have turned too far, either with one or both variometers. Take it *slowly* at first. If you get the station, but the signals are not clear, try adjusting the Bradleystat and potentiometer. These last two adjustments are very necessary on distant stations.

It might be well to add here that if any capacity effect is noticed on either variometer, try reversing the two leads and see if that does not do away with it.

If, after trying all this, you do not pick up any signals, change your switch on the coupler primary and try again. The longer the aerial, the fewer turns you need on the primary. The shorter the aerial and longer the wavelength of the station, the more turns you need. Now, if you don't hear anything, check over the wiring again.

The loading coil in the secondary can be used for all broadcasting stations, but it is most helpful on the class B stations or those having a wavelength of 400 meters and over. In this case use the middle tap (30 turns) and for 500 to 600 meters use the full coil (or 60 turns). It will be found with this coil in the circuit that more attention has to be paid to the adjustment of the plate variometer, and the writer believes that it makes his machine much more selective. For, while using this coil, he can separate stations that could not be separated without it. It will also be found that where a station comes in clearly with the grid variometer the set at 110° (on a 180° dial), and the plate variometer at 90° (without the coil), you will now have to turn the grid variometer to about 100° and the plate variometer will have to be set around 110°. But with practice this coil will prove very efficient. The writer has heard three stations in California six nights in succession, a distance of more than 3,350 miles, and they always came in at the same setting of the dials.



Mr. Bartholomew's station list is so remarkable, especially when it is appreciated that he is located about 500 miles south and 900 miles east of the lower end of Florida, that we are printing it in full.\* You will note that all the stations heard are more than 1,000 miles from Garrochales, and that six are more than 3,300 miles away.

CALL LETTERS	LOCATION	MILEAGE
KDKA	East Pittsburg, Penn.	1,650
KFI	Los Angeles, Calif.	3,350
KHJ	Los Angeles, Calif.	3,350
KOB	State College, N. Mex.	2,675
KOP	Detroit, Mich.	1,850
KPO	San Francisco, Calif.	3,525
KSD	St. Louis, Mo.	1,950
KUO	San Francisco, Calif.	3,525
<i>Examiner</i>		
and <i>Herald</i>		
KYW	Los Angeles, Calif.	3,350
WAAK	Chicago, Ill.	2,000
WAAM	Milwaukee, Wis.	2,050
WAAP	Newark, N. J.	1,550
WAAW	Wichita, Kan.	2,250
WBAK	Omaha, Neb.	2,300
WBAP	Harrisburg, Penn.	1,575
WBAV	Fort Worth, Texas	2,150
WBL	Columbus, Ohio	1,725
WBT	Anthony, Kansas	2,275
WBZ	Charlotte, N. C.	1,400
WCAL	Springfield, Mass.	1,600
WCX	Northfield, Minn.	2,300
WDAE	Detroit, Mich.	1,850
WDAF	Tampa, Fla.	1,225
WDAJ	Kansas City, Mo.	2,150
WDAL	College Park, Ga.	1,400
WDAR	Jacksonville, Fla.	1,250
WEAF	Philadelphia, Penn.	1,500
WEAO	New York, N. Y.	1,500
WEAY	Columbus, Ohio	1,725
WFAT	Houston, Tex.	2,000
WQAM	Dallas, Tex.	2,100
WFI	Sioux Falls, S. D.	2,400
WGI	Miami, Fla.	1,050
WGM	Philadelphia, Penn.	1,500
WGR	Medford Hills, Mass.	1,600
WGY	Atlanta, Ga.	1,500
WHA	Buffalo, N. Y.	1,775
WHAF	Schenectady, N. Y.	1,075
WHAM	Madison, Wis.	2,100
WHAO	Pittsburg, Penn.	1,650
WHAS	Rochester, N. Y.	1,775
WHAZ	Savannah, Ga.	1,250
WHB	Louisville, Ky.	1,725
WIP	Troy, N. Y.	1,075
WJAN	Kansas City, Mo.	2,150
WJAX	Philadelphia, Penn.	1,500
WKY	Peoria, Ill.	2,000
WJZ	Cleveland, Ohio	1,750
WLK	Oklahoma City, Okla.	2,200
WLW	Newark, N. J.	1,550
WLAG	Indianapolis, Ind.	1,825
WLAL	Cincinnati, Ohio	1,725
WLAK	Minneapolis, Minn.	2,325
WLAT	Tulsa, Okla.	2,125
WMAB	Bellow Falls, Vt.	1,700
WDAP	Burlington, Iowa	2,100
WMAQ	Oklahoma City, Okla.	2,200
WNAC	Chicago, Ill.	2,000
WMAF	Chicago, Ill.	2,000
WMAJ	Boston, Mass.	1,600
	Round Hills, Mass.	1,600
	Kansas City, Mo.	2,150

\*Regarding this list, Mr. Bartholomew writes:

"Have also picked up many other stations including Denver, Colo., and parts of telephone conversations between Avalon, Calif. and Catalina Island; but have not included them in this list as I have not heard call letters and location together.

"All of the above stations were heard on *one step of amplification only*. On two steps I use a home-made loud speaker (Baldwin unit and horn), and with it I have heard California 30 feet from the horn."



CALL LETTERS	LOCATION	MILEAGE	CALL LETTERS	LOCATION	MILEAGE
WMAK	Lockport, N. Y.	1,775	WWI	Dearborn, Mich.	1,850
WMAT	Deluth, Minn.	2,350	WWJ	Detroit, Mich.	1,850
WMAZ	Macon, Ga.	1,400	- CANADA		
WMC	Memphis, Tenn.	1,800	CHYC	Montreal, Quebec, Can.	1,850
WOAI	San Antonio, Texas	2,175	CFAC	Calgary, Alberta, Can.	3,500
WOAN	Lawrenceburg, Tenn.	1,700	- CUBA		
WOAW	Omaha, Neb.	2,300	PWX	Habana, Cuba	1,000
WOC	Davenport, Iowa	2,100	F. H. Jones	Tuinucu, Cuba	900
WOI	Ames, Iowa	2,225	- AMATEURS AND EXPERIMENTAL STATIONS		
WOO	Philadelphia, Penn.	1,500	2EL (on phone)	Freeport, N. Y.	1,500
WOR	Newark, N. J.	1,550	1XAE (on phone)	Springfield, Mass.	1,600
WOS	Jefferson City, Mo.	2,050	2XI (on phone)	Schenectady, N. Y.	1,675
WPA	Forth Worth, Texas	2,150	- TOTAL MILEAGE, AIR LINE . . . . .		
WPAC	Okmulgee, Okla.	2,100	172,075		
WPAL	Columbus, Ohio	1,725	- BROADCAST STATIONS HEARD . . . . .		
WQAO	Parksburg, Penn.	1,525	90		
WRP	Camden, N. J.	1,550	- AVERAGE MILEAGE . . . . .		
WSB	Atlanta, Ga.	1,500	1,911		
WSY	Birmingham, Ala.	1,600			

MR. BARTHOLOMEW'S OUTFIT COMPLETE



# Unloading the Mail from the Transatlantic Liners

By M. G. CARTER

**I**N ACCORDANCE with certain existing laws, the contracts with the various steamship companies provide that all foreign mail brought in on their ships shall be delivered to the receiving Post Office at the expense of the steamship companies. The New York Harbor Mailboat Service is maintained to facilitate the rapid handling of incoming foreign mail by utilizing the time spent by the ships in passing public health inspection at quarantine.

There are times when the mail-carrying ships from South America, the West Indies and abroad arrive too late to pass the doctor at quarantine which sometimes means a delay of twelve hours. However the mail is not delayed, but is taken aboard the mailboats and brought to Pier 72, North River, New York, and thence by trucks or train to the distributing Post Offices. This relieves the steamship companies of the considerable expense of trucking the mail to the Post Office, and min-

imizes congestion on the piers after the ships have docked.

The Harbor Mailboat S.S. *President* (radio call letters, NURL) is the flagship of a fleet which includes two and sometimes three steam lighters each capable of carrying from two to three thousand bags of mail, while the *President* has a capacity of approximately five thousand sacks.

A twenty-four hour watch is maintained every day of the year in all kinds of weather, by three crews both on the dock and on the mailboat. This is necessary because the ships arrive at all times of the day and night. It is the radio operator's job to receive notification of the approach of mail-carrying vessels as far in advance of their arrival in quarantine as is possible; to ascertain the amount of mail on board, where it is stored, whether separated or not, and the approximate time of the vessel's arrival in quarantine, so that those in charge can prepare various organizations to handle the mail.



FROM SAILOR TO "PRESIDENT"—IN FIVE SECONDS

The Harbor Mailboat *President* is shown in action alongside the *Mauretania*. Fifty sailors on each side of the liner drop the mail down the chutes as fast as possible. The day this picture was taken, 7,500 bags—approximately 60 carloads of mail—were transferred to the mail boats in an hour and twenty-eight minutes

By the receipt of such information the extra men are not ordered on duty until necessary. This saves the Post Office Department money on each ship met, amounting to a considerable sum at the end of the year. Some of the ships carry from four thousand to twelve thousand bags of mail, and for these, special schedules are made for boats, trains and auto trucks, and extra men must be secured to perform the service expeditiously.

It is interesting to note that during the past year 1,470 ships were met and approximately 750,000 bags of foreign mail handled. December was the heaviest month, with a record of 95,801 bags taken from the ships at quarantine.

The Post Office Department publishes a list of mail-carrying ships and their expected time of arrival in New York. The radio operators keep close watch on these ships for any irregularities in their time of arrival and amount of mail carried. For example, let us say that the *Mauretania* or the *Majestic* or the French Liner *Paris* is listed to arrive on a certain day with ten thousand sacks of mail. The radio opera-

tors watch for her and when within range send a message to the commander of the vessel, somewhat as follows: Commander, *Majestic*. Please advise number sacks mail how much on deck whether separated and time you expect reach quarantine. The reply soon comes back: Mailboat *President* 5165 bags New York City starboard 4061 bags Railroad port 803 bags Parcel Post hold number three expect reach quarantine 315 P.M. Commander, *Majestic*. From such information the clerks in charge are enabled to procure enough men and to dispatch such boats as are necessary to handle that particular situation.

On the other hand, suppose that a thick fog prevents the boat from coming up the channel to quarantine and she anchors off Ambrose Channel Light-vessel. It becomes necessary to keep posted by radio as to the exact movements of the vessel so that no mailboats will be dispatched aimlessly. If conditions permit, the mailboat often goes to Gravesend Bay, or even to Ambrose in fog, gets the mail, and returns to her pier; and the mail is delivered in Philadelphia, Pittsburg, and Boston before



the ship docks! Then again, suppose that a ship approaches that ordinarily carries mail, but this particular trip has none. It is by radio that such information is obtained, and a trip to quarantine is made unnecessary. As another example, a boat may be listed as carrying five hundred sacks of mail, but stops at another port en route to New York and picks up perhaps fifteen hundred sacks. If it were not for the radio reports, a small crew would be dispatched which could not handle such an amount of mail while in quarantine.

The radio equipment on the Mailboat *President* comprises a U. S. Navy 1-KW 500-cycle spark transmitter which has a daylight range of two hundred miles. The receiver consists of a U. S. Navy short-wave receiver with detector and a U. S. Army low-frequency amplifier type SCR-72. With this receiver, ships are picked up two thousand miles east of New York. All communications between the boat and the pier are made through the New York Navy Radio Station, NAH.

The important fact regarding the radio service is that the operators who maintain the watches are men of experience. Four men make up the radio personnel: J. Maresca, H. L. Swart, O. N. Johnson and M. G. Carter



CHIEF OPERATOR M. G. CARTER AT THE KEY  
In the radio room of the Harbor Mailboat *President*

(operator in charge). All of these men have had at least ten years', and some fifteen years', experience in such organizations as the Radio Corporation of America, International Radio Telegraph Company, Signal Corps, Navy, and the Air Mail Radio Service. Consequently, the work is handled with uniform efficiency, in spite of the fact that in the vicinity of New York the radio traffic is very heavy.

#### MAIL FROM THE OLD COUNTRY AND POINTS EAST

Before the *Manchuria* arrives in New York Harbor, the sacks are brought up on deck ready to be tumbled down the chutes when the mailboats come alongside. Boat No. 28 is shown receiving the mail, with No. 14 and No. 6, near by, about to steam off to take mail from the *Mauretania*



# The Grimes Circuit with Outdoor Antenna and Counterpoise

An Adapted "Inverse Duplex" that has Brought in California from Boston, Massachusetts

By HERBERT E. DILL

I AM using apparatus built in accordance with several published descriptions of the David Grimes "Inverse Duplex" three-tube set, with an outdoor antenna and a counterpoise, tuning by means of a standard Remler variocoupler and 43-plate and 23-plate condensers.

To enumerate the stations listened to each night and frequently well into the morning, would be literally to copy the lists of prominent broadcasting stations one finds in the radio column of the daily press. I am not missing anything. Having completed this Grimes circuit to my entire satisfaction, I have gladdened the hearts of a score of amateurs in my community by turning them loose without restriction upon my junk-pile of coils, con-

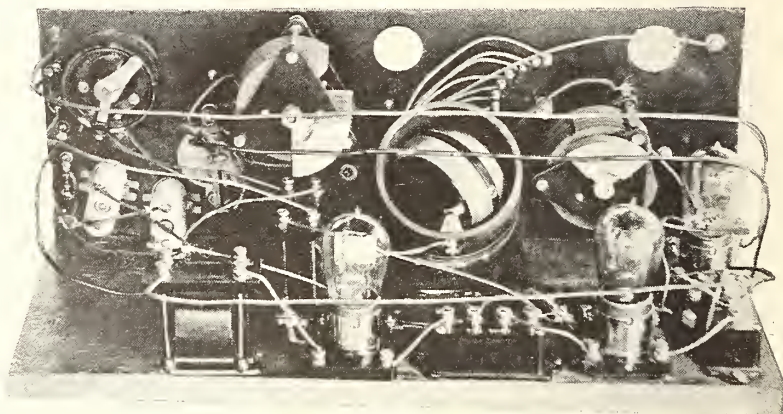

THE INVERSE DUPLEX SET MADE BY THE AUTHOR

densers, variometers, tuners and the like with which my den and attic and cellar have been littered for two years. It is such a pleasure to have *just one outfit* in the corner of my den and to feel satisfied with the results it gives me.

My circuit diagram is like the one published in RADIO BROADCAST for April, except that the loop is replaced by the apparatus indicated in (Fig. 1). Cunningham tubes, type 300 and 301 are used; Acme R2 and R3 and Chelsea transformers; General Radio variable condensers and potentiometer; Micadon fixed condensers; and Eveready large size block B batteries. The storage battery is of 100-ampere-hour capacity, kept well charged by means of a Tungar rectifier.

Difficulty has been experienced in selecting rheostats for this circuit because very careful adjustment of filaments seems necessary. Excellent results were obtained experimentally with separate

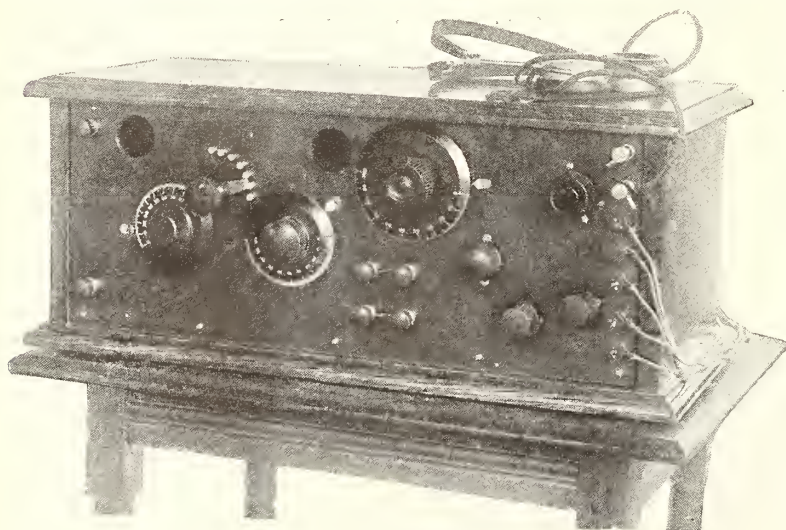

A NEAT JOB

After he had successfully made and operated this set, Mr. Dill gave away all the radio "junk" he had accumulated in the past two years





MR. DILL AT HIS "JUST ONE OUTFIT"

FIG. 1  
The secondary terminals replace the terminals of the loop (Fig. 2)

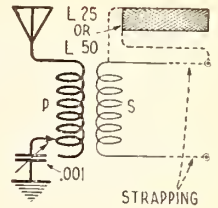

controls improvised of resistance wire with sliding contacts, but these are hardly suitable for neat panel mounting.

A Remler variocoupler is employed to permit experiments with various types of antenna ground and counterpoise, but by removing the strapping connecting two pairs of binding posts on the front panel, the Remler tuner is disconnected and any type of loop may be wired directly to the set.

The specifications of the original Grimes set that appeared in the April issue of RADIO BROADCAST have been carefully followed, with the exception of the addition of this variocoupler for tuning, and the installation of the separate filament controls. Extraordinary success with this Grimes circuit is due principally to my excellent location, the use of an outdoor antenna, and a counterpoise calculated to work perfectly with the set.

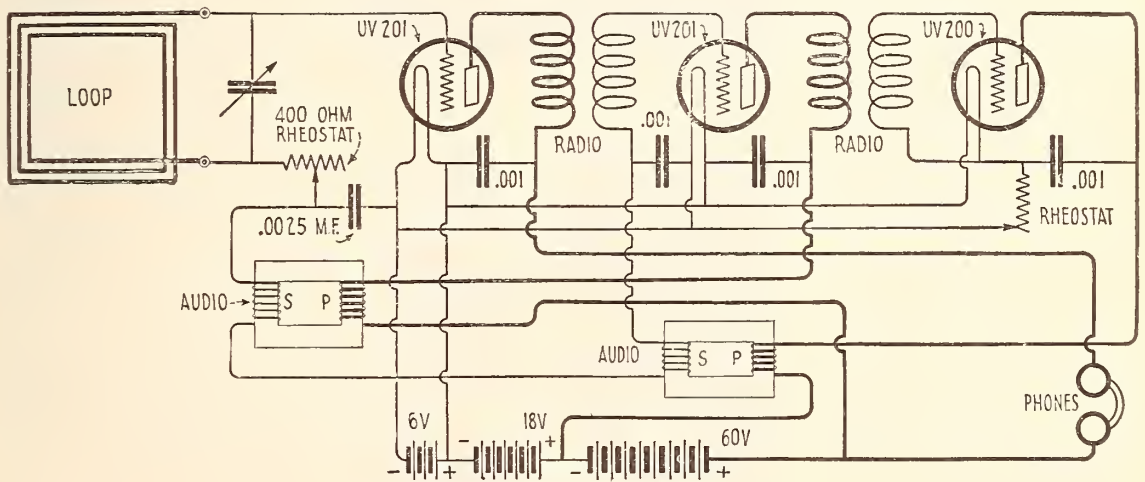

FIG. 2

The regular hook-up of the Grimes "Inverse Duplex." The only changes made by Mr. Dill in constructing his own set are the use of separate filament controls and the antenna and counterpoise arrangement shown in Fig. 1. A double-pole, double-throw switch, cutting in a loop, might be employed to advantage—especially when it is desired to receive from local stations

# Radio Angling and Fisherman's Luck

The Thrill that You Get When the Game Takes the Fly, and the Way that You Feel When It Doesn't. The Inspiration and Power for Good of Broadcasting, as Seen by One Clergyman

By REV. H. F. HUSE

In an editorial published in a previous issue, we expressed the belief that radio would prove a valuable asset to the preacher in the small town, in broadening his vision and educating him in a manner otherwise impossible. The Rev. H. F. Huse, Pastor of the United Baptist Church in Dover-Foxcroft, Maine says, in telling of the single-tube receiving set built by his fifteen-year-old son:

"One night, just before starting for a church service I heard a beautiful voice at WSB, Atlanta, Georgia, singing 'The Heart that was Broken for Me.' It tuned my soul at once for the service I was to lead." And again, "I shall never forget Miss Bennett's voice and the words as they went out from WOR, Newark, N. J. in the transoceanic broadcasting concert of February 24th . . . her wonderful voice came with a clearness that was startling. It made one think of the shepherds long ago, startled, as they were, in their midnight vigils by voices out of the air. I listened with rapt interest to the greetings she spoke at the end of the concert: 'I wish to express the great privilege I feel has been mine in singing to the people, not only of my own country, but also to the people of France, Italy, Belgium, Switzerland, and other countries of Europe. I send my most cordial greetings to all. . . . ' Such, I thought, is the spirit of America, the spirit of Christianity, the spirit of good will the world needs. Moreover, broadcasting is glorified as it scatters this cordial good feeling to the ends of the earth."

THE pleasures of radio are many and varied. There is first of all the satisfaction which comes in acquiring the information that accompanies all this new knowledge, the energies, the subtleties, the mysteries of radio. There is the wonder of this new thing, this agency that makes it physically possible for us to hear instantaneously out of the air the voice of man from the ends of the earth. There is the joy of a new and wholesome interest in life. There is the delight in the friendship and fellowship of those whose voices we hear over the air, and whose wonderful talent we so much enjoy. There is the delight of the family circle gathered about the radio set in the home. And not least among the pleasures of radio is the angling for stations!

More than once this winter as I have sat at the receiving set, and twisted the dials first one way and then another, in trying to pick up a station, I have thought of the similarities and the contrasts between casting upon the radio

waves for a station strike, and whipping the surfaces of pond and stream for the sudden flash of yellow and gold, the strike that means the battle royal with the red-spots, and at last the pleasure of leading Mr. Trout by the nose or walking him upon his tail into a fish basket for my lady's dinner the next day.

I taught my boy to fish before he was in his teens. Now that he is in his teens he has come back and taught me radio. And what a time we have had together, with phone on ear, angling for the stations, and what a thrill as we have landed them, the little ones and the big ones, all the way from Dover-Foxcroft, in the heart of Maine, to Tuinucu, Cuba in the South, and to Kansas City, the home of the Night Hawks, in the West.

In angling for stations as in angling for trout, sometimes the game takes hold and sometimes it doesn't. When the stations do bite, it gives you a thrill of pleasure; and when they don't, it sometimes tries your patience; but a true sport in radio, as



I TAUGHT HIM TO FISH



in fishing, takes things as they come without too many complaints.

I once took a friend fishing to a fine brook where I had always had good success. I wished very much for this friend to see some of the beauties that I knew were in its sequestered pools and swift currents. But that day they just would not bite. And this friend of mine stood on the bank and "joshed" me for fair:

"Trout! This brook never saw a trout! Let's go up in the woods and fish, we will get just as many as we get here, and then we won't get our feet wet!" Well, I've talked the wonders of radio to friends. I have told them the fine speeches and splendid music we hear, and how at times the box just bursts with sound! And then I have invited them in for an evening. I have seated them at my side and adjusted the phones and then begun angling. I have angled and angled. But it has been an off night. Nothing doing. A few ripples in the radio waves, but nothing worth while coming in. I have felt that their thought of radio was like that of the friend on the bank when the trout would not come to the hook.

Last night I invited in a friend. It was Sunday night and I wished very much to pick up a good church service. Like children whom we wish to speak their pieces before company, and sometimes fail us, so at times it is with radio. Nothing took hold very well until after this friend had gone and then with another twist of the dial I picked up WBZ, Springfield and heard a fine address by the pastor of the Methodist Church of that city!

I taught my boy fishing and he has taught me radio. When the fifteen-year-old came home and said: "Dad, we are behind the times. We have got to have a radio set," then it was time for the boy's best chum to sit up and take notice. I made the agreement that if he would find out how to construct a set, and convince me that he could do it, I would dig down and see if I could find the wherewithal

to pay the bill. "Say, Dad, you're the real article! The set is ours. I have the parts we need all down on paper, their prices, and the hook-up." The eighth wonder of the world is the way a boy in his teens learns these new things—and so quickly! We looked over the list of parts and prices. The total cost was \$40.92.

In due season, the box was made, the parts that we sent for came, and the set was constructed. The antenna was hung from the parsonage to the church vestry, and I was thankful indeed when this job was ended, without broken legs or pneumonia from climbing and scrambling over snow-covered roofs with the wind blowing a gale and the mercury down below zero.

In radio as in fly fishing the "hook-ups" are as varied as the fifty-seven orders of pickles. Speaking of flies, Henry Van Dyke says: "The blasé trout demands something new, something modern. It is for this reason that an altogether original fly, unheard of, startling, will often do great execution in an over-fished pool." So it is with radio sets and hook-ups. Every now and then it's the new hook-up that seems to gather in the stations.

#### THE HOOK-UP AND THE CABINET

WATCH the fisherman," says Henry Van Dyke again. "When he comes home with a full basket of trout on his shoulder, or a quartet of silver salmon covered with green branches in the bottom of the canoe. His face is broader than it was when he went out, and there is a spark of triumph in his eye." Who is there who has not seen the radio smile on the face of another, or felt the thrill in his own soul the morning after a successful catch? What fisherman returning home at night from an all-day outing to brook or pond has not been greeted with the question: "What luck?"

Our radio record began Sunday night, February 11, 1923. Up to the date of this writing our parsonage radio creel has to its credit the



HE TAUGHT ME RADIO



SOMETHING DOING IN THE AIR

following stations a thousand or more miles distant: KSD, PWX, WDAF, WDAJ, WFAW, WLAG, WMC, WOAW, WOC, WOS, WSB, SKW (Tuinucu, Cuba), and WKAQ. Considering our location in the heart of Maine and upon the outer circle of the area that includes the broadcasting stations, our catch is "not too bad."

Reflecting upon what has come out of the air to the listeners, one cannot fail to be impressed by the wonderful talent that everywhere in America seems to be the same—talent of speech and song, orchestra and band, solo and chorus. Parenthetically, as a preacher, may I say that the way in which the broadcasting stations have so generously lent themselves to the service of the churches is one of the finest instances of religious cooperation in a big way that the Christian world has ever seen.

Would that there were time and space to tell something about certain speeches and sermons and music that I have heard. It is said that Daniel Webster put together his famous reply to Haynes as he fished along the waters of a New England trout stream. Be this as it may, the radio listener finds not only mental change and rest in what comes to him out of the air, but

he finds inspiration to better things and nobler effort.

There have been such fine things from all the stations that it does not seem fair to mention one without mentioning all. But the "big fish" that I have missed someone else catches! There stands out in my memory the "New York City Symphony" from WEAJ, the "Albany Chorus" from WGY, the exquisite music from the "Waldorf Astoria" through WJZ, and the selections by the Little Symphony Orchestra via KDKA. One night just before starting for a church service I heard a beautiful voice at WSB, Atlanta, Georgia, singing "The Heart That Was Broken for Me." It tuned my soul at once for the service I was to lead.

I shall never forget Miss Bennett's voice and words as they went out from WOR, Newark, N. J. in the transoceanic broadcasting concert of February 24th. It was midnight. The transmission conditions were perfect, and her wonderful voice came in with a clearness that was startling. It made one think of the shepherds long ago, startled, as they were, in their midnight vigil by voices out of the air. I listened with rapt interest to the greetings she spoke at the end of the concert. "I wish to express the great privilege I feel has been mine in singing to the people not only of my own country but also to the people of France, Italy, Belgium, Switzerland, and the other countries of Europe. I send my most cordial greetings to all, and, to the people of Concord, N. H., my love."

Such, I thought, is the spirit of America, the spirit of Christianity, the spirit and goodwill the world needs. Moreover, broadcasting is glorified as it scatters this cordial good feeling to the ends of the earth.

#### THE RADIO ANGLER'S ROD AND REEL





# Crystal Receivers are Well Worth While

Some Types that are Simple to Put Together, Cheap, and of Value Both to Beginner and Confirmed Enthusiast

By ZEH BOUCK

Are you: interested in radio but without any experience in it; eager to enjoy the programs that fill the air, and to have the fun of building or operating your own receiver; broke—or at least unwilling to pay “beaucoup francs” for apparatus which you think you cannot operate, to hear programs which you think you may not care for? If so, get yourself a crystal set and have a taste of radio reception before tackling vacuum-tube apparatus.

Or, if already of the radio fraternity, are you building and rebuilding, soldering and unsoldering apparatus that passes in a single week through the throes of super-regeneration and inverse duplex? If so, build yourself a crystal receiver as a standby to tide you over whenever your tube set is *hors de combat*, so to speak. —THE EDITOR.

THE advent of the dry-cell tube, and the general drop in the price of vacuum-tube apparatus has by no means sounded the knell of crystal receivers. The advancement in bulb apparatus has been accompanied by similar strides in crystal equipment, notably in the development of synthetic crystals which make possible fairly consistent reception over moderately long distances. Experienced operators still recommend the purchase or construction of crystal receivers by beginners, as the least expensive way of mastering the fundamentals of tuning, and by the possessors of bulb apparatus as a standby when tubes burn out and batteries run down. When bulbs have suddenly ceased to function, many an interesting program has been “saved” by requisitioning a discarded crystal set. Also, a familiarity with the theoretical and practical aspects of crystal reception is of value in the operation and design of many reflex sets, in which a crystal is used as the detector.

The crystal provides the simplest means of detecting radio signals, and reception is effected by imposing the incoming radio-frequency energy on the circuit containing the detector, where it is “rectified.” The radio current, as the reader is probably aware, is an alternating current and of so high a frequency that, due to a phenomenon known as reactance, it cannot pass through the windings of the telephone receivers. However, by means of rectification, which the crystal accomplishes

through its property of passing electricity in only one direction, half the alternating current is suppressed, leaving only that part traveling in one direction (a direct current), which passes quite readily through the receivers.

There are several ways in which the radio wave may be delivered to the crystal, but as the sound from an unamplified crystal set is actually furnished directly by the power of the received wave, which is necessarily weak, only two methods, those making the most of the weak radio impulses, will be considered. The fact of direct power transformation, from energy of radio frequency to energy of audio frequency, should be constantly borne in mind when building crystal apparatus, to emphasize the necessity of painstaking construction tending to eliminate all possible losses. A carelessly made tube set may work, its imperfections probably being manifest in un-

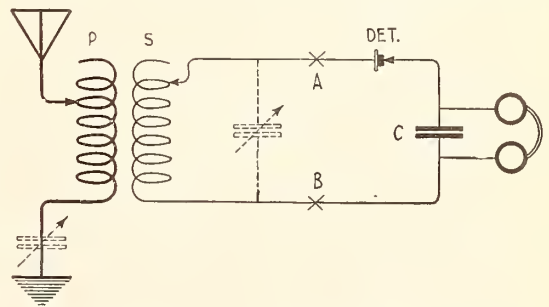

FIG. 1

The preferred crystal circuit, which, with the addition of the indicated condensers, makes an excellent set

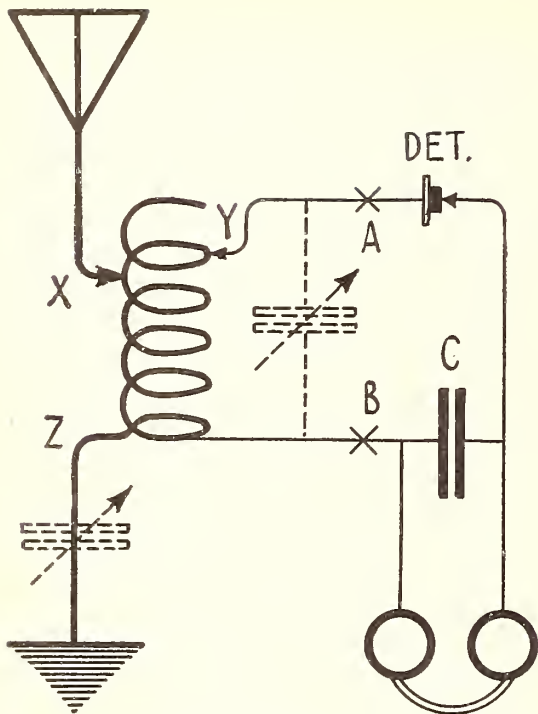

FIG. 2  
An efficient and simpler circuit

desirable sounds and lack of selectivity; but a poorly constructed crystal receiver, incapable of compensating for inefficiencies by local batteries, will function far below its ability.

The most efficient system of crystal reception employs a loose- or variocoupler in the tuning circuit. Fig. 1 indicates the manner in which it is connected to the detector and phones. The coupler, P S may be of the type designated commercially as the "universal" or "all-wave" coupler, or it may be a standard short-wave variocoupler with the secondary coil rewound (if necessary) with smaller wire. Good variocouplers can be had from reliable dealers for from \$2.75 to \$6; for the person who does not care to make his own apparatus and yet would be glad to save money by assembling bought parts himself, the purchase of a variocoupler is recommended. Many complete crystal receivers, of course, are also on the market. They cost comparatively little to buy, and nothing at all to operate, since they require no bulbs or batteries. However, a home-made coupler is well within the ability of many experimenters, and the primary coil should be wound with 60 turns of any convenient wire on a three-and-a-half-inch tube, tapped every sixth turn. The secondary may be

wound with 72 turns on a three-inch tube, tapping every twelfth turn.

If the fan already possesses a short-wave variocoupler, but does not care to rewind and tap the secondary, a variometer may be added to the circuit at point A, figure 1, and tuning accomplished by means of it.

The loose-coupler circuits are very selective, and close tuning is possible through variation of the coupling.

A single coil of wire combining the functions of both primary and secondary, is, perhaps, the more usual form of inductance for crystal reception, but while quite efficient, it necessarily lacks the advantages gained by variable coupling. This circuit, Fig. 2, is theoretically identical with that just discussed, the turns of wire between X and Z acting as the primary, and those between Y and Z as the secondary coil. (It might be well to note here that the functioning of many electrical circuits, particularly those associated with wireless, depends upon one coil acting in the capacity of two or more.)

The inductance coil in Fig. 2 may be wound with 120 turns of No. 20 to No. 28 magnet wire, and tapped every tenth turn. Fig. 3 shows the method of doubling up on the taps, permitting the two switch levers to cut in individual amounts of wire from the same taps.

The fixed condenser, shown across the telephone receivers, should be of about .0015 microfarad capacity.

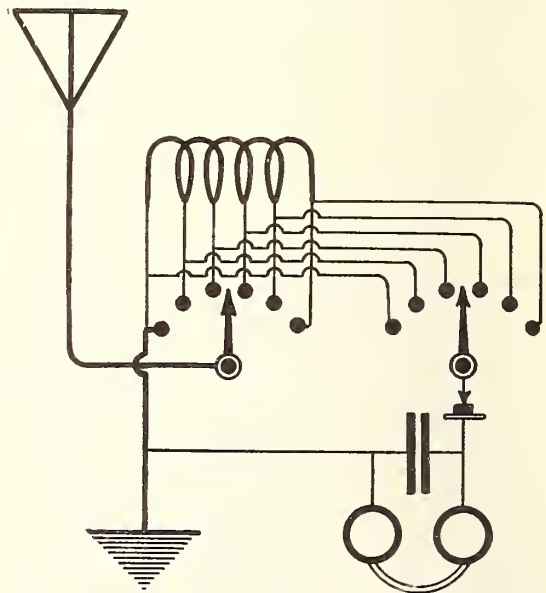

FIG. 3



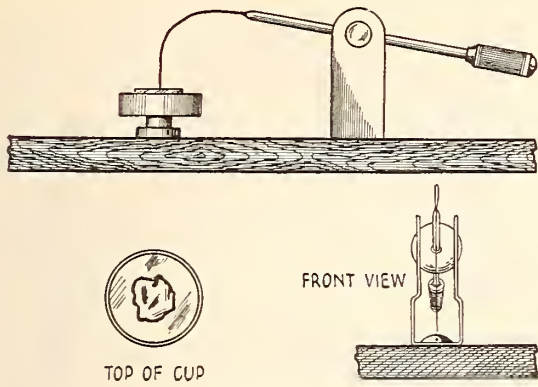

FIG. 4

A simple form of crystal detector for home construction

The crystal sets just described are well adapted to the refinements associated with audion equipment, and the addition of variable condensers in the primary and secondary circuits will add to the selectivity, and to the ease with which the apparatus may be tuned. Such condensers are indicated by dotted lines in Fig. 1 and are preferably of the 43-plate (.001 mfd.) size, though the 23-plate condensers will be found useful. If only one condenser is available, it can probably be used to greater advantage across the secondary coil, in the loose-coupler circuit, and in the ground-lead when the tuning coil is used. Whether or not condensers are employed, apparatus constructed in conformity with the directions given, will respond to all the broadcast wavelengths.

The detector itself may be any one of the popular types on the market, from the simple moving-bar design to the more elaborate

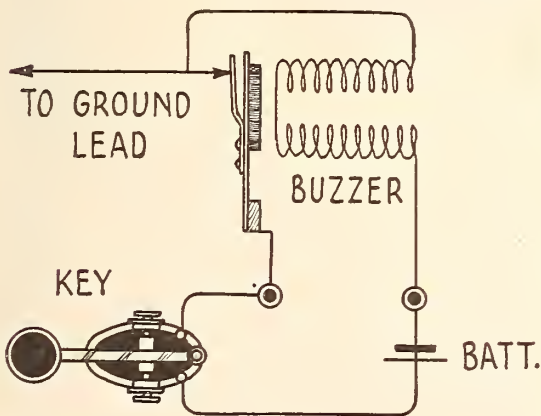

FIG. 5

Test buzzer connections

glass-enclosed instruments. The majority of crystal detectors are of the cat-whisker type in which contact with the crystal is effected by means of a fine, springy wire such as phosphor-bronze. Such a detector is easily built by the experimenter. A simple design is shown in Fig. 4. The support is a "U" shaped strip of brass or other convenient metal. The ball and the brass rod which is passed through it after drilling, may be made from the end of a curtain ring. The cat-whisker (a short, single strand from a flexible lighting cord, will do for this) is soldered to one end of the rod, while an insulating handle is attached to the other. The crystal may be purchased mounted in a revolving cup.

Another popular detector design which is particularly adapted to mounting on a vertical

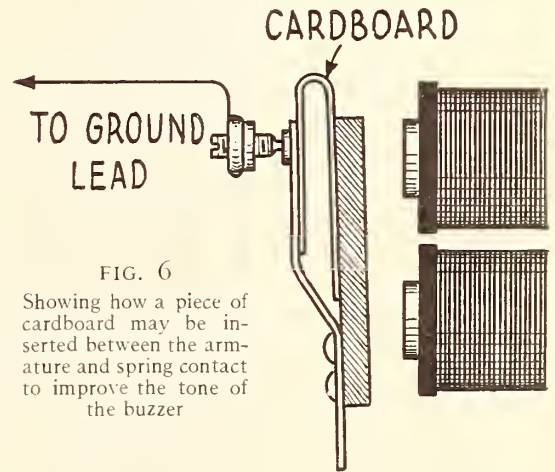

FIG. 6

Showing how a piece of cardboard may be inserted between the armature and spring contact to improve the tone of the buzzer

panel is that of the rotating type made in the form of a hard-rubber wheel. It contains a sensitive crystal with which contact of the required delicacy is obtained through gold or other metallic dust. Adjustment is effected by turning and tapping the wheel.

The crystal itself may be galena, a natural crystal, or a synthetic product, which is sometimes more sensitive than the average natural mineral. Galena is a double sulphide of lead and silver along with many unrectifying impurities—all in varying proportions. It is not difficult to imitate the natural process of galena crystallization, and the majority of manufactured crystals are merely an artificial galena built up in the most efficient proportions (from a rectifying standpoint) with the useless and perhaps undesirable impurities eliminated.

A crystal set is most easily adjusted for the

highest sensitivity by means of artificial signals from a test buzzer. The buzzer, though preferably of the high-frequency type, may be of the ordinary door-bell design, the note of which can often be improved by inserting a pasteboard slip between the armature and the spring contact (Fig. 6). The sole connection between the buzzer and receiver (and no connection at all is required when the detector is correctly adjusted) is a single wire running from the stationary contact to the ground-lead (Fig. 4). The detector should be adjusted while the key or push-button is down, and the note of the buzzer will be plainly audible in the receivers when a sensitive adjustment is secured.

The apparatus is preferably mounted on a panel after the fashion of bulb sets, with the detector placed on the front in such a manner as to permit easy adjustment. A push-button may be set flush in the panel for operating the buzzer test, but many enthusiasts prefer a telegraph key on the operating table, making the buzzer additionally useful for code practice. Care should be taken in the construction and mounting of the instruments, in order that the crystal receiver may be given the finish and appearance which it merits.

#### ADDING AN AUDION TO THE CRYSTAL RECEIVER

THE crystal sets which have been described employ a tuning system that is readily adaptable to bulb reception, it being merely necessary to build up the bulb equipment as an auxiliary unit. The additional parts which will be required are: the bulb, A and B batteries, socket, rheostat, grid condenser and grid leak, and the plate variometer. The extra equipment should be connected as shown in Fig. 7, and is hooked up to the crystal receiver by connecting wires A' and B' to wires A and B respectively in Figs. 1 or 2 after eliminating the detector and receivers (the phones of course being transferred to the bulb circuit).

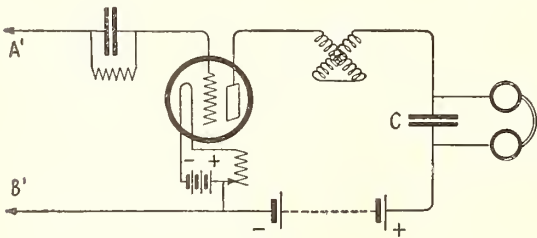

FIG. 7

The bulb unit for connection to Figure 1 and 2. This will make the crystal set into a regenerative receiver

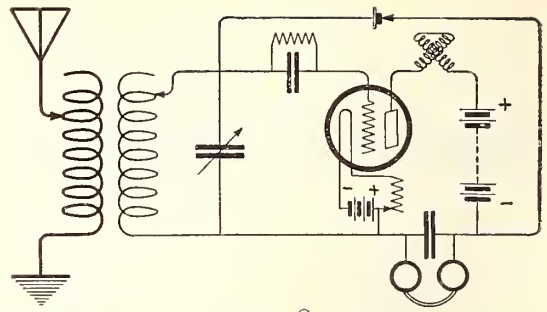

FIG. 8

A combination audion-crystal set, permitting instant change to either form of detection

The result will be an efficient regenerative receiver, which, if desired, may as easily be changed back to a crystal set.

Fig. 8 shows a combination crystal-tube set in which either form of detection is immediately available. When tube reception is desired and the tube is lighted, it is merely necessary to remove the cat-whisker from its position on the crystal. When crystal reception is preferred, the current that lights the bulb is turned off and the cat-whisker is adjusted to rest lightly on the crystal. No switches are required unless it is desired to keep the detector permanently adjusted, in which case a single-pole single-throw switch may be placed between the crystal detector and the phones, thus obviating the necessity of removing the cat-whisker. The principle is quite clearly indicated in Fig. 8, and it may be applied with equal simplicity to almost any crystal or bulb circuit which you may at present possess.

The crystal receiver is capable of remarkable results when constructed and operated with some degree of "finesse"—which, alas, is often as totally lacking in radio as in bridge. The close of the war found crystal receivers covering fifty to a hundred miles, *on amateur power and wavelengths*; and until much more recently they were used almost exclusively for commercial work (due to patent complications on bulb apparatus), traffic being handled in many instances over distances of a thousand miles! Of course, you cannot expect to hear broadcasting stations a thousand miles away with a crystal set, and even fifty-mile reception may be considered exceptional; but if you live within about twenty-five miles of a broadcasting station, you should be able to hear it consistently and plainly; and the music will come in without the distortion so common with sets employing vacuum tubes.



# Powel Crosley, Jr.—“The Henry Ford of Radio”

By ALVIN RICHARD PLOUGH

**T**HE other day I visited two large radio plants where several hundred people are daily engaged in turning out radio apparatus to meet the tremendous demand for such products. When I was ushered into the office of the president of this enterprise, I found that he was a much younger man than I had expected; in fact he confessed to being thirty-six. His youth impressed me and I marveled at his ability to grasp big problems and make quick decisions. What ability he has along this line, he says, has been developed through the many and varied things he has done during his business career.

Those who knew Powel Crosley, Jr., President of the Crosley Mfg. Co., as a very young man, refer to him as a “rolling stone” type of boy; but now they are glad to “hand it to him” as a sound business man. Such has been the change in sentiment about the man who operates the radio plants I visited in Cincinnati, and who has been referred to as “the Henry Ford of radio,” because he builds such large quantities of good and comparatively inexpensive radio apparatus.

Mr. Crosley told me that it was in 1921 that he first became interested in the radio business. He considers that he owes a great deal to his young son for the position that his company holds in the radio industry. It was on Washington's Birthday, just two years ago, that his boy, who was then nine years old, wanted a

radio set. He took the boy to the factory of the Precision Equipment Company, which was manufacturing receiving sets and is one of the original licensees under the Armstrong patent. It was Mr. Crosley's intention to buy an inexpensive set as a toy for Powel, 3rd, but he

found that the least expensive one cost about \$130, which appeared to him to be too much of an investment for a small boy's toy. The insistence of the boy was followed by the purchase of parts to assemble a set and notwithstanding the limited amount of broadcasting two years ago, Mr. Crosley and his son became ardent radio enthusiasts.

Less than two years after his first visit to The Precision Equipment Company's factory, he purchased a controlling interest in that corporation, which is now being operated as a separate organization, so that he is now at the head of two radio manufacturing companies!

The early career of Powel Crosley is very

interesting. Before going to work, his academic education consisted of public school and military preparatory school, one year of engineering work in college and two years at law school.

His first job was rebuilding some old telephones during a summer vacation while in the public schools. This was followed by work in various phases of the automobile business during summer vacations from college. During his last year in law school he was employed by a large bill-posting company to acquire leases



HE FIRST BECAME INTERESTED IN RADIO TWO AND A HALF YEARS AGO

Now he is head of two radio manufacturing companies



MR. CROSLY BROADCASTING AT WLW, CINCINNATI

on locations for their signs. Before completing his course in the law school, he decided that there were opportunities for quicker financial returns than in law, so he did not complete his course but obtained a position with a Cincinnati concern selling municipal bonds. This was followed by the organization of a small company, of which he was president, to manufacture a low-priced, six-cylinder car. This was in the days when there were not more than two or three six-cylinder cars on the market. Although the first car was built and operated successfully, others were never put into production because of a lack of sufficient capital.

A few years later, he took up advertising and sales work, which was followed by the organization of another automobile manufacturing company to build a very light six-cylinder car, and later, another company to build a light four-cylinder car. Neither of these companies went into production due to the lack of sufficient capital.

It was then, Mr. Crosley says, that he determined never again to attempt to operate on other people's money. He had experienced

several disappointments and now started over again, with the intention of making advertising his life work. He associated himself with an advertising agency on a drawing account of only \$20 a week in 1914, and later changed his connection to another agency. By 1916 he had built up a fairly large and profitable clientele. Through the service rendered to one of his clients, he was induced to become interested in the organization of a company to sell one and later several automobile specialties. This company he purchased outright in the spring of 1917, and it has grown to be one of the largest concerns of its kind in this country.

From all this it will be seen that Mr. Crosley has exceptional ability in business organization. But it was his realization of the difficulty of obtaining an efficient and inexpensive receiving set in 1921—and due also to the fact that he wanted something to manufacture which would keep his wood-working plant in full operation—that he plunged into the radio business and turned out simplified apparatus which could be manufactured in large quantities and sold at low prices.



# Reception de Luxe

By A. R. BOSCOW

**T**HE receiving set described in this article is of a type created to satisfy the ideals of the most lavish experimenter and amateur who wants a highly sensitive instrument, responsive to the 100-600 meter wave band, embodying as simple a system of control as is consistent with efficient operation. While there are no radical departures from standard radio circuits, the auxiliary circuits possess some novel features.

Before the final assembly of this set, practically every known receiving circuit had been tried during the previous twelve years that the writer had been experimenting with radio. This set, then, expresses what he believes to be the ultimate in receivers at the present time on the lower band of wavelengths and for actual performance and ease of control exceeds the seven-tube super-heterodyne operated at this station last year.

Practically all the stations heard have come in clearly on the loud speaker, which consists of a Vocarola attachment on a large horn, and most of the stations were heard with considerable volume on one step of audio amplification and quite a number on the detector alone. While the above remarks refer particularly to broadcast reception, it must not be inferred that this is the set's only feature, for amateur CW stations have been copied in every district.

The set employs six tubes—three radio-frequency stages, a detector, and two audio-frequency stages. The tuning circuits are arranged for either loop or antenna reception. When used with an antenna, the tuning elements consist of a primary condenser, a variocoupler and secondary condensers. When used with a loop, plugging in on the loop jack disconnects the primary circuit and variocoupler, leaving the secondary condensers in parallel with the loop for tuning. The primary

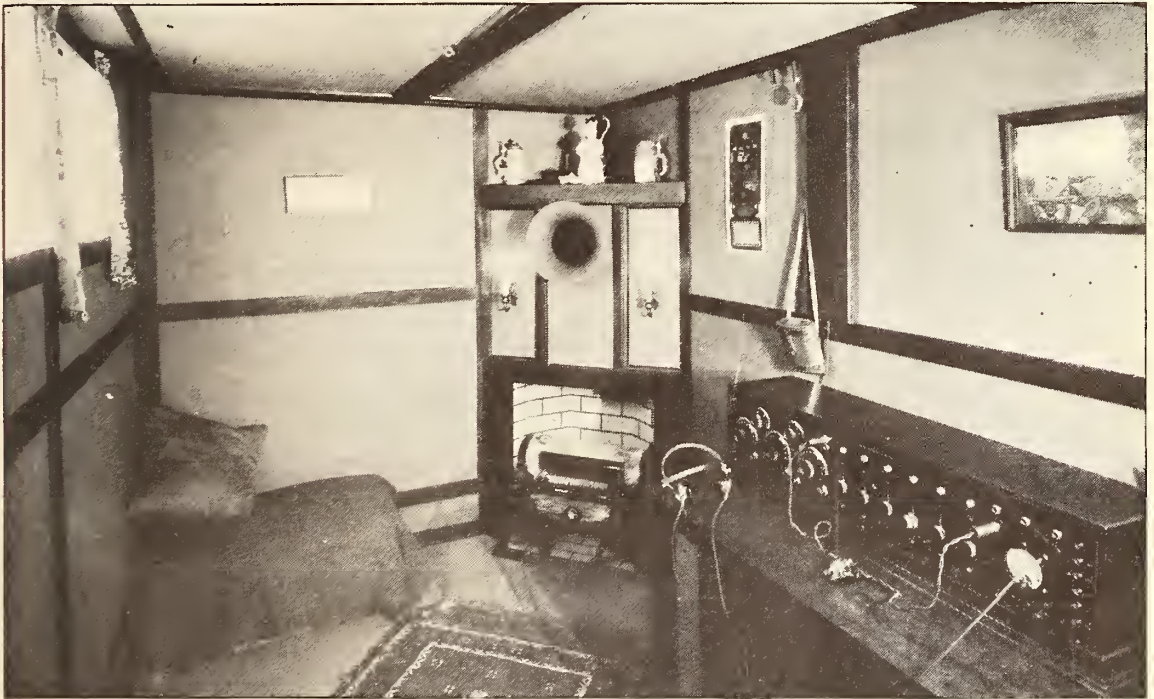

THE COMFORTABLE RETREAT WHICH MR. BOSCOW BUILT IN THE BASEMENT OF HIS HOUSE

The fireplace is electric and thermostatically controlled—no getting up from the set to put logs or coal on during the winter evening!

inductance is variable by means of a tap switch mounted on the back panel, while the secondary circuit is tuned by three condensers (two variable and one fixed). The shaft of the variocoupler was lengthened to include the shaft of the three-plate vernier condenser which is thus made to rotate with the coupling coil in such a manner that as the coupling is increased, the vernier condenser capacity is decreased, thus tending to stabilize the resonant point of the primary and secondary circuits and helping to prevent detuning when the coupling is changed. In parallel with this condenser is the main secondary condenser of thirteen plates which is in turn shunted by two .00015 mfd. condensers in series. When the main secondary condenser is set at 0, the secondary wavelength is approximately 180 meters and increases to 420 meters at full scale. If now one of the small mica condensers is cut out by the switch provided, the secondary wavelength becomes 400 meters at 0 and increases to about 600 meters at full scale. This arrangement gives a full vernier effect with a small variable condenser and still provides a large range of wavelengths.

In case it is desired to use the tuning elements without the radio-frequency bank, a

jack has been provided which enables a crystal or other detector to be plugged in. The tuning is accomplished in the usual manner.

In addition to the usual jack arrangement which enables the signals to be received on either the detector or the first or second audio amplifiers, an additional jack has been provided so that an external detector can be plugged in on the audio-frequency bank. This jack in connection with the one associated with the loop jack enables crystal reception, utilizing the tuning elements with or without audio-frequency amplification and makes an ideal arrangement for local reception.

A rather extensive system of voltage control has been provided and has proved to be an absolute necessity. A 0-10 D. C. voltmeter is connected through a two-pole, triple-throw, cam-key switch to three separate circuits, one of which follows along on a buss under the filament rheostats, to which is connected six double-pole single-throw push-button switches which are in turn connected, one to each of the tube socket terminals. With the key in the proper position, pressing any one of the push-button switches shows the voltage on the terminals of its associated tube. A second circuit from the key switch goes to the A battery terminals

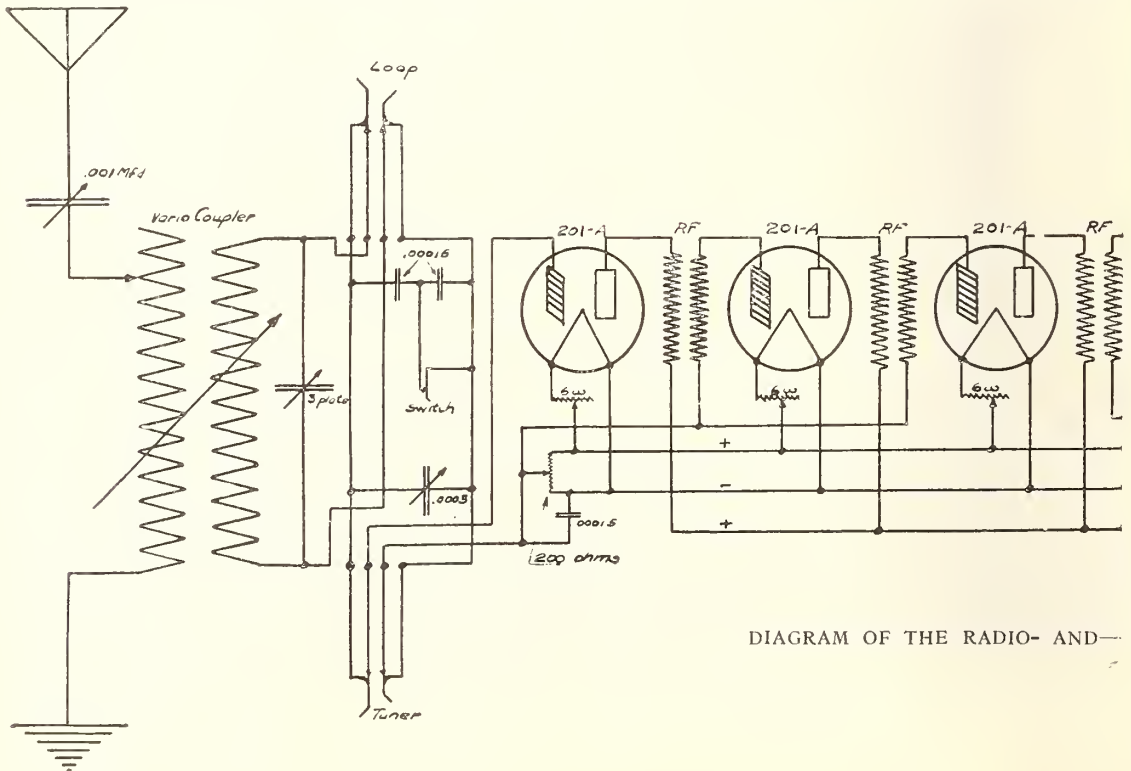
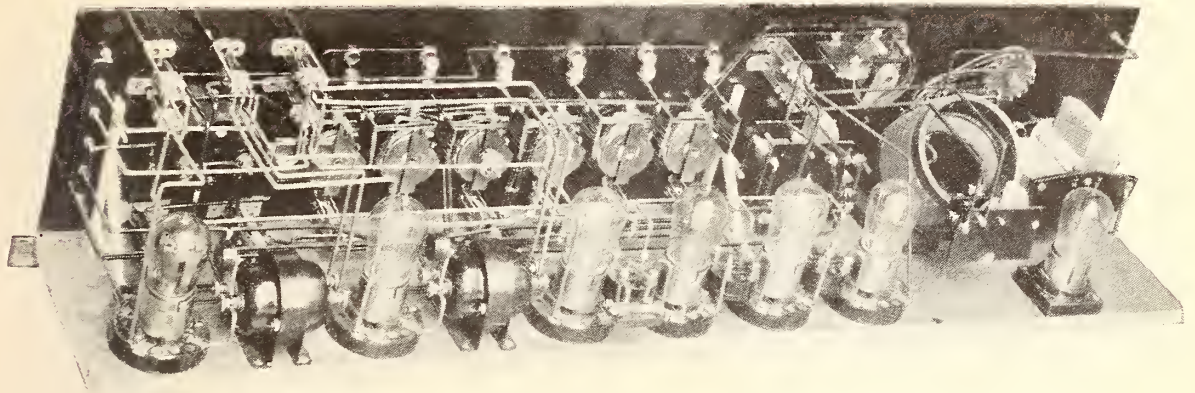

DIAGRAM OF THE RADIO- AND—





IT IS A PLEASURE TO SEE A HOME-MADE SET AS NEATLY BUILT AS THIS

so that the condition of the storage battery may be determined at will. The third circuit goes through a high resistance to the B battery terminals and enables a reading of the plate voltage. The amount of this resistance varies with different makes of voltmeters but should be of such a value that a scale multiplier of 10 may be used. That is to say that when the key switch is thrown to the B battery position it is only necessary to make a mental calculation to get B battery voltage by multiplying the scale reading by 10. Such an arrangement

permits readings up to 100 volts on a 10-volt meter.

Because of the amount of equipment in the set, it was not possible to have the tubes so located that their filaments could be observed through windows or holes, and an auxiliary indicating system was provided. Above each rheostat control knob has been placed a small bullseye, similar to those used in the older types of telephone switchboards. Behind each bullseye a 2-volt 1-candle-power light has been placed and connected through a suitable re-

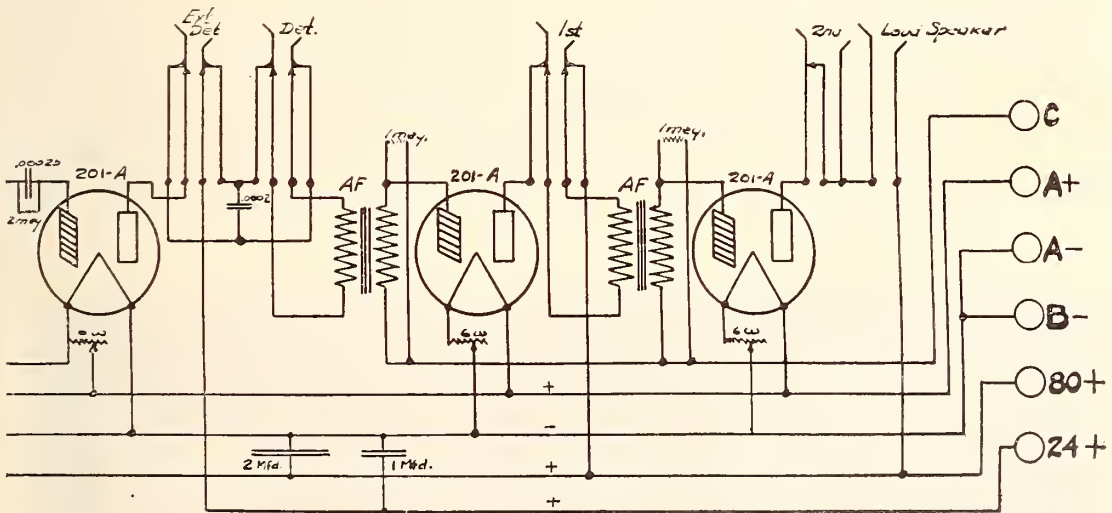

—AUDIO-FREQUENCY CIRCUITS

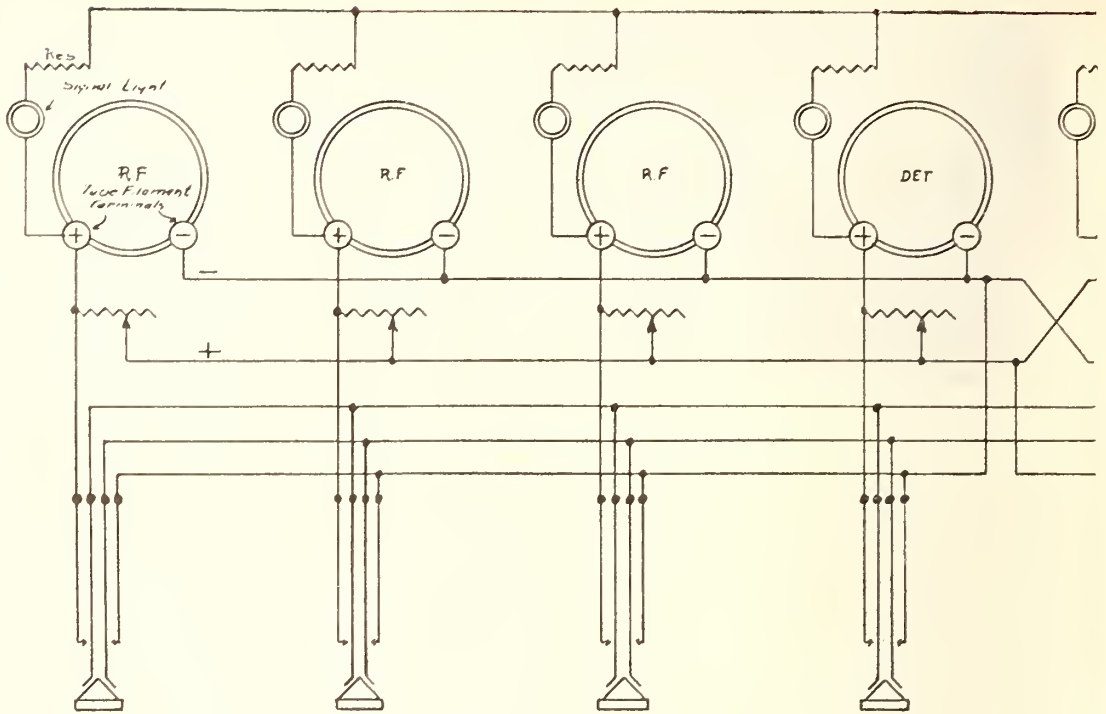

THIS DIAGRAM SHOWS THE VOLTAGE-CONTROL AND INDICATING-LIGHT—

sistance, wound on flat bakelite strips, to the tube side of the filament rheostat. As the filament of each tube is turned on the indicating lamp also lights, giving an attractive as well as an effective indication of the tubes in use.

The common returns from these indicating lamps are connected to a second key switch which is in series with the main filament leads from the A battery which provides three switching combinations:

- 1.—All A battery current off.
- 2.—A battery on tube filament buss.

- 3.—A battery on tube filament buss and indicating lamp circuits.

These combinations make it possible to operate the set with or without the indicating lamps being lighted.

Binding posts are provided for the following terminals; antenna, ground, A battery leads, B battery leads and audio amplifier grid bias, the first two being located at the left end of the panel, while the others are at the right end. The panel is of bakelite  $\frac{3}{8}$ " x 8" x 38" and is screwed to the wooden base along the bottom

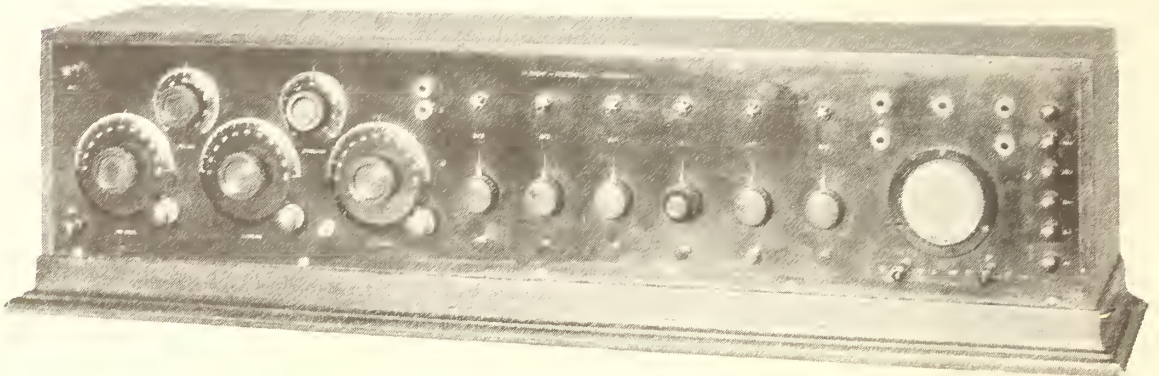

DE LUXE IS THE WORD FOR IT

Note the small pilot lights above the six rheostats, indicating whether the vacuum tubes are lit or not



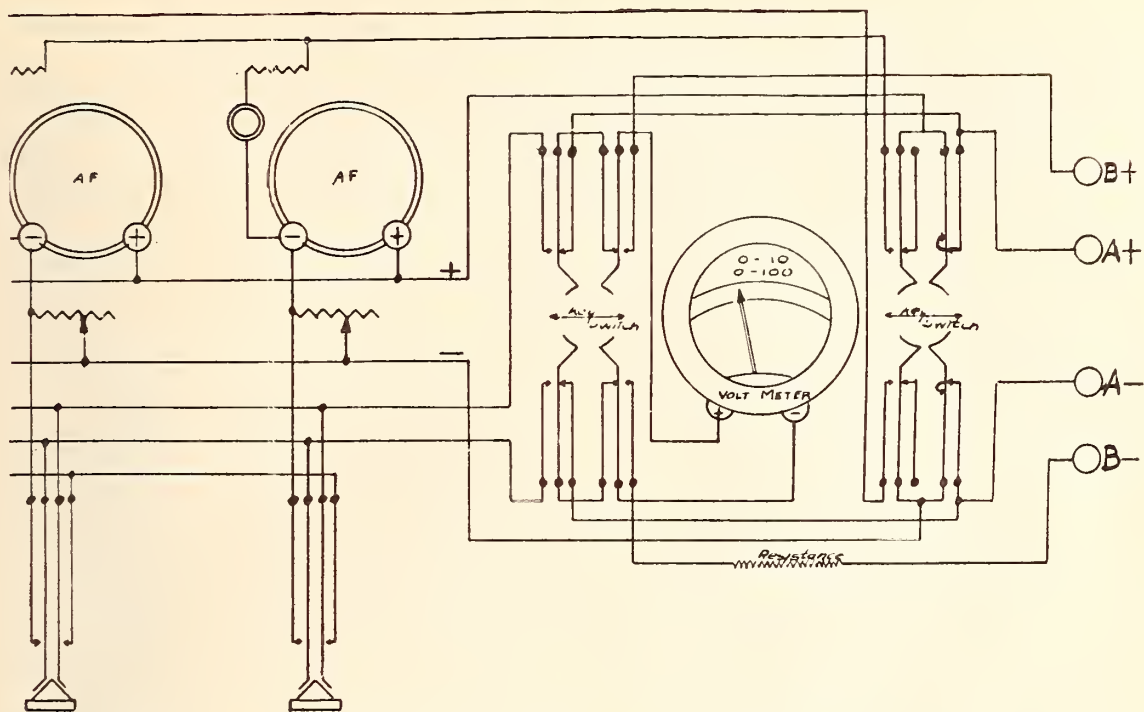

—CIRCUITS AS USED BY MR. BOSCOW IN HIS ELABORATE RECEIVER

of the panel and is maintained in an upright position by cast aluminum brackets. This panel and base are arranged so that they will slide in and out of the mahogany case. Rubber-rimmed vernier controls make for easy manipulation.

With the exception of some of the voltmeter leads the set is wired throughout with No. 14 copper wire covered with "spaghetti". Red colored covering is used for the primary circuits, green for the secondary circuits (the same as the wire covering on the variocoupler), and yellow for the balance of the radio and audio frequency wires. Black covering is used for the battery and other circuits.

The following standard parts were used in the construction of the set:

Binding Posts	EBY
Dials	Chelsea
Rheostats	Cutler-Hammer
Jacks	Pacnet
Variable Condensers	Wireless Shop
Fixed Condensers	Micadons
Vario-Coupler	Remler
R. F. Transformers	Murad
A. F. Transformers	Radio Corp.
Tubes	" " 201-A
Sockets	" "
Potentiometer	" "
Grid leak and Condenser	Dubilier
Voltmeter	Jewell
Vernier knobs	Arkay

THE ANTENNA

THE antenna is of cage construction 4 inches in diameter at the outer end, tapering to two inches at the lower end, with a 1 inch, three-wire cage lead-in. The flat top has 4 wires (No. 14 hard-drawn copper wire) and is 40 feet high at one end and 30 feet high at the other. This construction amounts practically to a one-wire antenna, but with the wire in cage style built on small brass rings of increasing diameter. The reason for this kind of antenna was an attempt to reduce the high-frequency resistance.

HOW THE SET IS OPERATED

THE A battery switch being closed, the successive filaments are adjusted so that the proper voltage is impressed on each tube. This procedure is made easy by the conveniently placed voltmeter push button located under its corresponding rheostat. This method of always burning the filaments at constant potential insures consistent duplication of long-distance reception as well as conserving the operating life of the tubes. The detector tube filament temperature is somewhat governed by its plate voltage as well as by the position of the stabilizer, so that it often

happens that its filament is operated above or below normal temperature. This adjustment can only be determined by experiment and varies from time to time. As both the radio and audio amplifier banks are connected to one plate voltage buss, their plate potential is the same and appears to be best at about 75 volts. The detector plate voltage is a variable factor, but gives best results at about 24 volts, when amplifier tubes are used throughout. A grid bias of from  $1\frac{1}{2}$  to 3 volts on the audio-frequency tubes prevents distortion at that point as do also the 1-megohm grid leaks connected across the output of the audio-amplifying transformers. As it is essential for best telephone reception to operate the receiver without local oscillation, the stabilizer is adjusted until this condition is obtained. The tuning now becomes nothing more than a rough adjustment of the antenna circuit by means of the primary inductance tap switch in conjunction with the primary condenser, a variation of coupling until a signal is heard, then an adjustment of the secondary condenser until maximum signal is obtained. A reduction of coupling is then advisable and slight readjustments of the condensers until you have the signal as you want it. With a minimum of coupling, the receiver is most selective, and by rotating the secondary condenser it is possible to go rapidly from one station to another without interference between them although they may be on only slightly different wavelengths. In this respect the set is so selective that it is possible to tune out a local 500-watt station on 492 meters and bring in a 360 meter station 1,100 miles away. Due to the radio-frequency amplification there is but little loss in signal strength when used with a minimum of coupling.

Some of the distant broadcasting stations

heard by the writer in Portland, Oregon include:

STATION	LOCATION	AIR LINE MILES
KLZ	Denver, Colo.	1035
KSD	St. Louis, Mo.	1810
KFAF	Denver, Colo.	1035
WDAF	Chicago, Ill.	1860
WCX	Detroit, Mich.	2100
WOC	Davenport, Ia.	1710
WSB	Atlanta, Ga.	2270
WBAP	Fort Worth, Tex.	1680
WDAF	Kansas City Star	1575
WHAZ	Rensselaer, Troy, N. Y.	2550
CHCF	Winnipeg	1315

#### USING A LOOP

IF IT is desired to use a loop, the tuning operation consists simply of varying the secondary condenser and the direction of the loop until the signal is at a maximum, always keeping the stabilizer down just below the oscillating. Frequent voltage tests of both the A and B batteries, as well as of the filament potentials, are essential to consistent and successful operation.

The "De Luxe" part of this radio reception would not be possible in a cold garage or among a crowd of visitors in the living room, for instance, so I have given my set an attractive and comfortable place to live in by building a small room in the basement with a painted linoleum floor and paneled walls and ceilings of plaster board. Comfort is assured by an electric fireplace (thermostatically controlled) in one corner of the room, from the top of which appears the horn of the loud speaker. Reception of a sort is possible with almost any kind of apparatus, but not the least enjoyable feature of it consists in being able to sit in your own cozy room, listening to St. Louis, Los Angeles, or Calgary, as the notion happens to strike you, and knowing that you will not be troubled with interference of any kind.

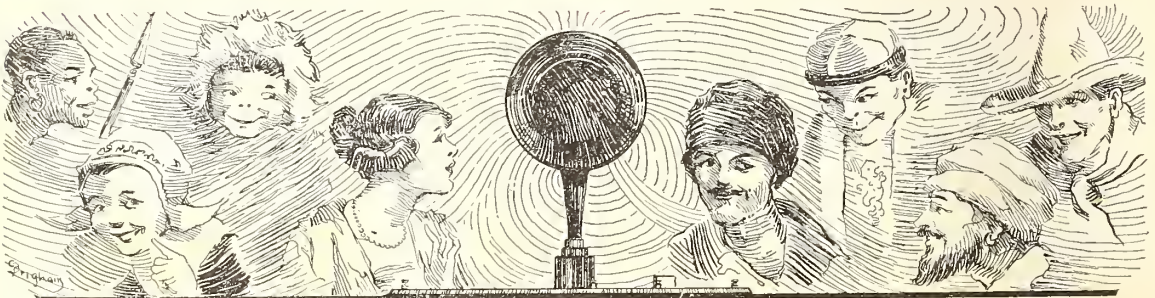



# Teaching School from a Broadcasting Station

A Successful Test by WJZ and the New York Board of Education

By LLOYD JACQUET

**T**O BE the first group of students instructed by radio, is something of a distinction, and it seems to belong to the class in accounting of the Haaren High School, in New York City.

At a recent meeting of educators, attended by officials of the Board of Education and members of the faculty, it was decided that the experiment should first be carried out at the Haaren High School under the direction of Mr. R. Wesley Burnham, the principal, and Mr. Fred Siegel of the faculty. This was to be the

first experiment made to determine the feasibility of conducting a course of instruction by radio in an educational institution in New York or elsewhere.

Accordingly, WJZ, the Westinghouse broadcasting station, was chosen as the station through which to conduct the experiment. sensitive receiving sets were installed in the school room and at headquarters in the Board of Education Building, through the courtesy of the Radio Corporation.

Voice amplifiers were attached to the receiv-



A CLASS IN ACCOUNTING AT THE HAAREN HIGH SCHOOL CONDUCTED BY RADIO

ing sets, so that a large audience could hear the broadcast simultaneously.

Promptly at 1:15 p. m. on a particular afternoon, the announcer's voice came through loud and clear. At the Haaren High School, 11 Hubert Street, New York, the buzz of conversation stopped abruptly.

Dr. Gustave Straubenmuller, Associate Superintendent of the Board of Education, was the first speaker.

"Thirty pupils of the Haaren High School sitting in a classroom in their school building will be instructed by their teacher from the WJZ studio. This is the first time that pupils are being instructed this way."

He was followed by Mr. Burnham, Principal of the High School. He told, briefly, of the part-time and coöperative plan of education.

All the speeches were taken down in shorthand by students in the class room.

A few seconds later, Mr. H. W. Leyenburger, head of the Business Practice Department, addressed his class in accounting, and began the lesson.

"I am glad to greet my class in Machine Calculation in this way," said Mr. Leyenburger. "In the classroom about thirty girls are assembled for regular work in Machine Accounting. To-day the class room is equipped with a loud speaker. Miss Ella Hastings, the class teacher, is in immediate charge of the work.

"The problems that will be given involve the four fundamental processes: Addition, Subtraction, Multiplication, and Division. Now, if you are ready, I will give the first problem—

"Question No. 1. Find Trial balance," said Mr. Leyenburger, whose voice was per-

fectly registered in the classroom. "4832.60; 5392.75; 3570.00—Answer!"

In the classroom, the adding machines were going full speed. One question followed another at a brief interval, until the six problems, involving addition, percentage, cost plus, division, pro rata, etc., were all given.

A few minutes after the lecture was completed, the correct answers to the problems were sent out and received at the Board of Education headquarters, where they were checked up against the results arrived at by the students. The overwhelming correctness of the pupils' work testifies to the faultless manner in which radio waves carried the many details of the complicated problems, every one of which had to be received perfectly to permit of a correct solution.

Principals of more than twenty-five city high schools were interested listeners-in at headquarters. Far away classes in business schools were interested audiences also.

Haaren High School was not the only one to receive this instruction. Other high schools, radio equipped and operated by the pupils, also listened-in, and the telephone brought to waiting officials reports of successful reception from schools scattered all over the city. This was proof conclusive that hundreds, even thousands of pupils in many widely separated locations can listen to leading instructors and educators with whom they otherwise would never come in contact.

Officials of the Board of Education were warm in their praise of radio as a factor in school education, and are already discussing methods for the immediate broadening of the service.

The advent of the "University of the Air" may be at hand.

## A Tablet Dedicated to the Radio Congregation

**A** BRONZE memorial tablet, donated by and dedicated to the invisible radio congregation of Calvary Episcopal Church, Pittsburgh, Pa., was recently unveiled during the church services of that congregation. The Rev. Edwin J. van Etten, pastor of the church and the first minister to have his services broad-

casted; Bishop Alexander Mann, of the Pittsburgh Episcopal diocese; H. P. Davis, representing Station KDKA, which station first broadcasted the church services; and other prominent Pittsburghers took part in the ceremony.

More than 4,700 people, representing 40 states of the Union, five provinces of Canada,



Cuba, Bermuda, London, and ships sailing the Atlantic Ocean contributed to the purchase of the tablet. The contributions came in every form of legal tender—silver dimes, stamps, nickles, pennies, and checks. There was a surprising number of Canadian dimes. A worker in a Southern cotton mill sent Dr. van Etten two cotton socks with a nickel in each toe. A sailor sent 120 pennies he had won playing penny ante.

These contributions came as a result of Dr. van Etten's idea that the radio congregation to which he had been preaching since January 2, 1921, might like to contribute to some sort of memorial.

Accordingly, during the reading of his regular church announcements, Dr. van Etten told his unseen hearers of a plan to have small contributions from such of them as might like to participate, the sum obtained to be used for a memorial.

Response to this idea was almost instantaneous. An hour after the announcement was broadcasted contributions were received from people living in Pittsburgh. People in the vicinity even walked to the minister's home a few minutes after they had heard his voice by radio and left their contributions.

The first announcement was sent out into the ether one Sunday last February, and contributions have been coming into Calvary Church ever since. The amount obtained, all of it in small contributions, has been used to purchase a beautiful bronze memorial tablet.

The tablet is 30 x 26 inches in size. On it is a bas relief map of the territory where Calvary's church services have been heard. The map is crossed with jagged lines, indicative of radio waves emanating from the radio station at East Pittsburgh.

On the tablet is the following inscription



#### THE DEDICATION OF THE RADIO TABLET

Mr. H. P. Davis, Vice-President of the Westinghouse Electric & Manufacturing Company, is standing nearest the tablet. On his right is the Rev. Edwin J. van Etten, pastor of the church, and believed to be the first minister in the world to broadcast a sermon. In front of Dr. van Etten is Bishop Alexander Mann, of the Episcopal Diocese of Pittsburgh, and at Bishop Mann's left is Mr. John Frazier who installs the Westinghouse Company's direct telephone connections for broadcasting outside events

which will undoubtedly be read with great interest in the years to come: "January 2, 1921, from Calvary Church for the first time in history a church service was broadcasted by radio wireless by the Westinghouse Electric & Manufacturing Company. This tablet was placed (1923) by the Unseen Congregation."

The words of H. P. Davis, Vice-President of the Westinghouse Company, made a deep impression on the visible audience, as no doubt they did on the unseen listeners miles away.

"Other cities have memorials, but Pittsburgh is proud to be the first to broadcast by radio to the world her own religious worship," declared Mr. Davis, "Pittsburgh is further proud to have as a citizen Rev. E. J. van Etten, rector of Calvary, the first minister in the world to catch the vision of sending his message out into the highways and byways by radio.

"It is impossible for me to express in words the great good he has done for thousands of people by recognizing and using radio for such

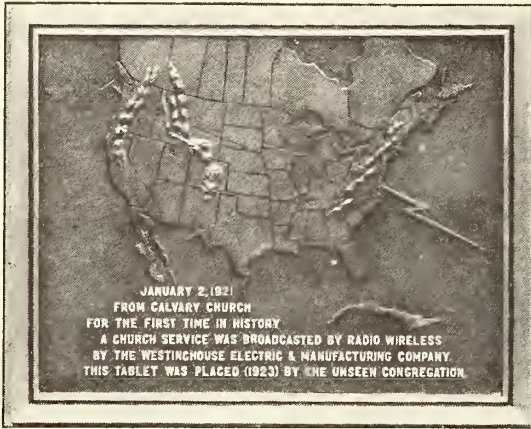

TABLET AT CALVARY CHURCH, PITTSBURGH

More than 4,700 people, scattered all over North America, contributed small amounts toward this memorial

a noble purpose. It has enabled him to reach and to console the sick and the shut-ins all over this continent, without detracting one iota from the excellent work he is doing in his own parish. Mr. van Etten has reached suffering people who have been cut off from church services for years and who never expected to hear church services again. His initiative has made possible this splendid memorial gift from which I have just lifted the American flag, which Calvary always will point to with pride.

"I see in the future constant pilgrimages making way to this spot where we stand to view this tablet and to read these words. You who gather about this church to-night are the first to make that pilgrimage.

"Pittsburgh is proud to be the home of Calvary Church, the first church in the world to extend by radio its services beyond its own parish, into every corner in the country, to an

audience which in numbers, in denominations, and in location never before has been comprehended.

"This testimonial of appreciation has come back to Calvary from the unseen congregation. The bronze tablet, for which contributions have come from more than 40 different states, from five Canadian provinces, from ships at sea, from England, Mexico, Honduras, and Cuba, is placed to commemorate in a prominent and permanent way the pioneering done by Calvary Church of Pittsburgh and Station KDKA in the broadcasting of church services."

Mr. Davis's talk and the singing of one verse of "America" by the surpliced choir and the audience, and Dr. van Etten's brief benediction all were broadcasted via the microphone which stood on a tripod near the speakers. Even the noise of the passing street cars and whirring auto engines could be heard by the radio listeners hundreds of miles away.

Dr. van Etten, who has preached nearly every Sunday to his radio congregation since his first sermon in 1921, declares the radio possibilities for the clergy to do good work are boundless.

"Mission churches without a parson may have the best religious services," he said. "Hospital wards have been equipped. Our parish is doing organized work by wireless. We have several receiving sets. The church home hears our services through one of the sets. The invalids of the parish are enjoying the use of two others. Outside our own parish family, groups all over the country gather at the library table for a wireless Sunday night worship. Thousands can have services who never had the chance before. I feel radio is a wonderful boon to the church."





# All Boy Scouts, Attention!

*RADIO BROADCAST* is holding a contest, ending July 31, 1923, to determine *WHAT BOY SCOUT TROOP HAS DONE OR IS DOING THE MOST WITH RADIO.*

## Prizes for Winning Articles

**FIRST PRIZE: CROSLY MODEL X 4-TUBE RECEIVER.**

*This receiver, which may be used with dry-cell tubes if desired, consists of detector, one stage of tuned radio-frequency and two stages of audio-frequency amplification. (Advertised in RADIO BROADCAST).*

**SECOND PRIZE: MUSIC MASTER LOUD SPEAKER.**

*This is the new loud speaker made by the General Radio Corporation. (A picture and description of it appear in the advertising pages of RADIO BROADCAST).*

**THIRD PRIZE: THREE**

*The WD-11 is the well-known dry-corporation. (Filament voltage 1.5, of the third prize may have UV-199's*

*A YEAR'S SUBSCRIPTION TO given as prizes for the ten next best*

*These prizes will be awarded to troop may delegate one of its members to*



**WD-11 VACUUM TUBES.**

*cell tube manufactured for the Radio plate voltage 22½—45). The winner or UV-201-A's if he prefers.*

*"RADIO BROADCAST" will be contributions in this contest.*

*troops, not to individuals, although any prepare the story.*

## Rules of the Contest

1. *Articles must be true accounts of radio with relation to your particular troop: what you have done, or are doing, or both.*
2. *Every article must be written by a Scout or by more than one Scout belonging to one troop.*
3. *Articles should be between 500 and 1000 words long.*
4. *Good photographs to illustrate the article will count 50% in judging contributions.*
5. *Typewritten manuscript, double-spaced, is desired, though not required.*
6. *Address contributions to Scout Contest, Radio Broadcast, Doubleday, Page & Company, Garden City, N. Y.*

*Scouts have done splendid work in maintaining communication by radio in time of floods and disaster, in copying and spreading the market reports transmitted by the government Farm Bureaus, in training themselves along mechanical and electrical lines, and, in short, in using radio as a part of scout work in a way consistent with the best traditions of scouting. What have you to tell of your troop's past or present activities? Get your scribes and photographers under way with that story which will put in a strong bid for first prize. How would a receiver with three stages of amplification go in your troop?*

*The winners will be announced in the September number, and at least one of the three best articles will appear in that issue.*

# Sets for the Great Outdoors

By A. HENRY

This article, prepared for RADIO BROADCAST by a radio man of wide experience should be interesting and helpful to all of you who are contemplating trips into the country this summer or autumn. Mr. Henry has used radio receivers in automobiles and small boats for several years, and his remarks on various types of bought receiving sets and their use may assist you in choosing a good outfit for yourself. A receiver on your vacation will be a source of great pleasure if it is kept in working order, but it will only be an extra package to lug around if it "goes bad."

The author has just returned from a thousand-mile automobile trip and some of the difficulties encountered are still fresh in his mind. He has prepared what we think is a very practical and helpful article.—  
THE EDITOR.

**Y**OUR vacation this year, and your shorter trips into the country, may be made much more enjoyable if you arrange to take a good receiving set with you. Receivers for any kind of use and suited to almost any pocket-book are now available, so that there is no reason why—even though you be in the woods of Maine or the mountains of California—the World Series baseball scores, music, and other entertainment should not come to you in the evening.

With most of us, the cost of a radio receiver is a rather important item, and for this reason it may be well to consider several types, ranging in price from a few dollars to two hundred or more.



A PORTABLE RECEIVER

That includes everything from the antenna to a spare tube. It was developed by Lyon and Healy, the Chicago music company

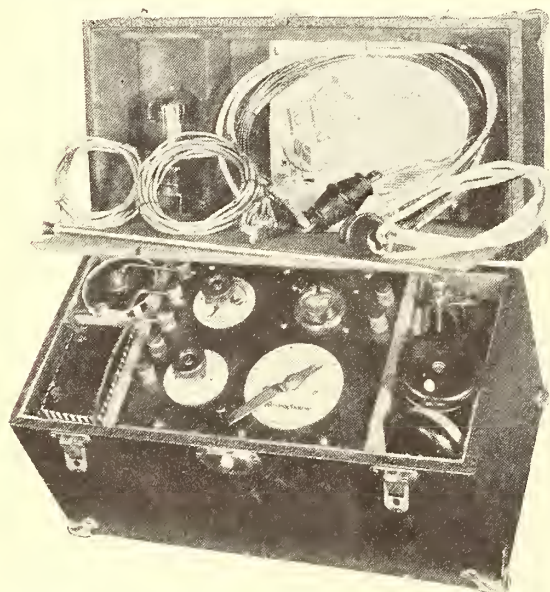

A PLACE FOR EVERYTHING  
Is found in this neat carrying case.  
Interior view of the set shown above

The single-tube receivers that have furnished so much enjoyment in your homes during the last few months will serve equally well on a camping or boat trip, provided, of course, there is room enough to erect a single-wire antenna. Where a single tube is used there are only two circuits that will prove satisfactory over any distance. They are the single- or double-circuit regenerative outfits and the single-tube reflex with a crystal detector. There is little need in dwelling upon the use of the home-made receiver, for any one who is ingenious enough to have made and operated one, will have little difficulty in shifting it from the house to the automobile or boat.

Realizing the great demand there would be for portable receivers this summer, some of the commercial companies have developed compact



machines that will work very satisfactorily over comparatively long distances. One receiver of this nature is the "Aeriola Sr.," which is made up with a tube that operates from a single dry cell and one small "B" battery. This receiver, along with a complete antenna equipment, tube, and batteries may be had for \$75. It is quite small and may be tucked away almost any place in the camping outfit and may be set up in a few minutes. A single-wire aerial stretched from a tree to your automobile from 50 to 75 feet and a few feet above the ground should receive at night over distances of five hundred miles.

Another and equally satisfactory portable receiver is the new outfit made by the Colin B. Kennedy Company. Where this outfit is used with dry-cell tubes, it is entirely self-contained with the exception of the antenna. It comes in a cabinet 15" x 7½" x 7" and weighs seventeen pounds. It sells for \$75 with tube, dry batteries, phones, and carrying case.

Another very compact portable receiver designed for use with two tubes, having the A and B batteries right in the carrying case, is known as the Radiola II. It is manufactured by the General Electric Company and sells without antenna equipment for \$97.50. With this outfit, it is necessary to put up the antenna and make some sort of a ground connection. The necessary equipment for this may be procured for a dollar or so. All the other wiring has been taken care of by the manufacturers.

A fourth outfit, and one which we believe will be found popular during the summer, has been made up by the firm of Lyon & Healy in Chicago. It incorporates a single tube regenerative receiver with the necessary batteries for operating it, a spare vacuum tube, and a complete antenna equip-

ment provided with shackles and ropes which make it possible to erect the antenna in a jiffy. All the equipment is placed in a well made containing case. This outfit sells for the reasonable price of \$100.

Where the antenna and ground connections would be inconvenient, it is possible to use some form of loop receiver. We have secured some very satisfactory results in operating a three-tube De Forest reflex outfit, using telephone receivers. This outfit may be had complete with UV-199 tubes, the necessary adapters, "A" and "B" batteries, and a pair of telephones, for approximately \$162. Where a loud speaker is desired, it is possible to use this De Forest outfit with an antenna from 25 to 50 feet long. No ground connection is necessary. In this



ON TOP OF THE WORLD IN THE CUMBERLAND MOUNTAINS

Louis G. Pacent, the radio manufacturer, C. F. Goudy, Instructor of Mechanical Engineering, Pratt Institute, and the author entertained a few Shriners on their way to the Washington gathering

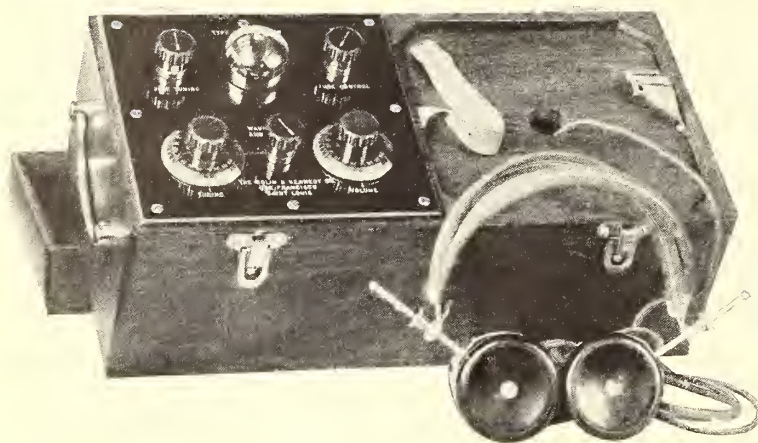

THE COLIN B. KENNEDY PORTABLE

case, however, instead of using UV-199 tubes, the 201-A's are found more satisfactory and may be operated from the automobile or boat storage battery as described a little farther on.

The De Forest four-tube receiver, called the D-10, may be used to operate a loud speaker with UV-199 tubes over comparatively long distances without an antenna, and inasmuch as the A and B batteries may be carried in the lower part of the receiver cabinet, this outfit is very practical for traveling. The necessary equipment, including the loud speaker, a good pair of telephones, and a carrying strap may be had for approximately \$225.

Where it is desired to operate without antenna, ground, or loop, the new four-tube Grebe receiver may be used. In this case, a single wire some twenty feet long, thrown over the top of the car or across the roof of the deckhouse on a boat, will work very satisfactorily and collect energy enough for the operation of a loud speaker over comparatively long distances. Where the auto or boat battery is used, it is already grounded to some part of the motor and the single wire is all that is necessary. It may be run around an auto top or up the mast on a boat.

#### ENTERTAINING A CROWD

**L**OUND speaker operation, as we have considered it so far, is not of the character that will entertain a whole community or supply music with volume enough for dancing in the open. This may be accomplished, however, if any good power amplifier is used. The Western Electric or Magnavox three-tube amplifier, for example, used with UV-201-A tubes operated from a storage battery and one

105-volt B battery and a 22½-volt B battery in series will be enough to supply music for the entertainment of rather large audiences.

It is quite likely that most vacationists will find that receivers operated from dry cells will suit their purpose best and there is little use in discussing receivers of this character, for those of standard make are supplied with complete instructions.

But where the automobile or boat storage battery is to be used to light the filaments, a certain amount of care must be

exercised to prevent the filaments being burned out, especially while you are in some place where new vacuum tubes cannot be obtained. In an automobile, plugging in on the storage battery is a simple matter. Most machines are provided with a dash light and the wiring system is made to accommodate either single- or double-contact bayonet-based lamps. By taking the lamp out of your dash socket you can determine the character of wiring in your machine. Having found this out, it is but necessary for you to call upon an automobile accessory store and procure an attachment plug from which a pair of wires may be led to supply the current for operating your filaments. In connecting these attachment plugs, care should be taken to have all the contacts firm. A loose contact will cause a great deal of noise. Before placing the wire in the attachment plug, it is a good plan to solder the end of each wire so as to make it a solid mass rather than a number of strands. By so doing the contact screw in the attachment plug will not cut through the thin wires and there is very much less possibility of a short circuit. The most suitable wire for work of this sort is called



SINGLE OR DOUBLE CONTACT

That's the question when you wish to use your auto storage battery to light your filaments. With one of these little adaptors plugged in your dash socket you can get "juice" in a jiffy



double-conductor Rome super-service cord. Number 16 will be found satisfactory. The wire in this case is entirely rubber-covered and it will stand a great deal of abuse and twisting without breaking. For its entire length throughout the cord, one wire is covered with a cotton material of a different color from the other, making it an easy matter to connect the positive side of the battery where it should be connected.

Another method of using the automobile battery—although not quite so convenient as the plug cord attachment—is using two large clips fastened to the end of the battery leads, which in turn are snapped on to the terminals of the battery. This arrangement, however, makes it necessary to lift the floor boards every time a connection is desired and on the road frequently results in the dirtying of clothes and the possibility of ruining them with the acid deposit found on an automobile battery. Great care should be taken to prevent any possible short circuits. The free ends of the leads from the storage battery should be kept well separated while the attachment plug is in the socket, unless they are connected to binding posts on the receiver.

In the event that ordinary lamp cord is used instead of this cord, the matter of determining the polarity of the storage battery is a com-

#### IT IS WELL TO SOLDER THE ENDS

When flexible cable is used, to prevent the binding screws in the plug from cutting the individual strands



paratively simple matter. It is but necessary to stick the leads into a raw potato and it will be found that a greenish deposit will soon appear around the positive lead.

#### DON'T BURN OUT YOUR TUBES

A SAFE method of preserving the filaments is to connect an ordinary 25-watt 110-volt lamp in series with them. Where this is done and the B battery leads happen to touch the A battery terminals, the filaments will not be burned out. This precaution is especially recommended where an attempt is made to operate the receiver from the automobile or boat battery while in motion. As a matter of fact, the use of the set under these circumstances is not recommended.

Some of the little stunts that will be found invaluable on the camping trip are shown in the accompanying illustration. Others will suggest themselves to you as you prepare for your trip. There is one word of caution that I would have you remember, for I believe it will offset the possibility of carrying a receiver that will be out of business when you want most to use it: *be sure that the receiver is packed well.* Do not leave it out until the last minute and then stick it wherever it will go, because the vibration is hard on soldered connections and they are likely to part. The safest place to carry vacuum tubes is in their sockets, but where the receiver is of the cabinet variety some soft paper or cloth should be put in on top of them. This should be removed when the set is in operation.

If you are not the owner of a set at present, in deciding upon the receiver to take with you it is well to remember that when your vacation is over you will want a good receiver in your home and it is well to consider, in purchasing the receiver, the amount of home use you are likely to require from it.

Another thing that will add to the pleasure of your trip is a camera. Photographs of your party entertaining people where radio was previously unknown, for instance, will be a source of pleasure to you, not only now but in the years to come.

## A CALL BOOK FOR THE AMATEUR

All the active amateur and broadcasting stations in the U. S. and Canada are contained in the fourth edition of the Amateur Radio Call Book, published by the Radio Directory & Publishing Co., 45 Vesey St., New York. A large two-color map, suitable for mounting on cardboard, is an added feature.

# A Practical Super-Heterodyne with 199's

By WALTER VAN B. ROBERTS

Princeton University

RADIO fans all over the country are constantly experimenting with "new hook-ups," and the papers and magazines are full of circuit diagrams. One might think that there were a vast number of really different methods of radio reception. Actually however, there are only a few fundamentally different schemes in use, and all circuits are based on these. For example, out of the fundamental idea of regeneration, there have sprung hundreds of apparently different regenerative receiving circuits. These may differ in ease of adjustment, but, *with the same tube and antenna, any type of regenerative receiver, if properly built, will be exactly as sensitive as any other type.* Hence, if you have a good regenerative receiver and are not satisfied with its sensitivity, there is no use wasting time and money trying other regenerative circuits. Rather, improve the one you have.

Nearly all circuits in use at present are based upon the following fundamentally different schemes for increasing the strength of the signals:

- (1) Regeneration
  - (2) Super-regeneration
  - (3) Radio frequency amplification
  - (4) Super-heterodyne
- } (a) untuned  
} (b) tuned

Without discussing these methods at length, their limitations and drawbacks may be pointed out briefly:

- (1) Regenerative circuits, when allowed to oscillate, annoy the neighbors, and the sensitivity obtainable without loss of quality is not great enough for the satisfactory use of a loop antenna.
- (2) Super-regenerative circuits are not very selective, and are noisy if the signals are weak.
- (3) Untuned radio-frequency amplification

with the present type of tubes is not entirely satisfactory (in the writer's opinion) due principally to unavoidable transformer losses.

Tuned radio-frequency amplification, with regeneration prevented by the "neutrodyne" principle, seems very satisfactory, except that for great sensitivity tuning becomes difficult on account of the large number of circuits that have to be tuned.

(4) The super-heterodyne method seems to have no inherent drawbacks or limitations. To justify

## THE ULTIMATE RECEIVER

In this comprehensive article, Mr. Roberts discloses the advantages of the super-heterodyne in which the intermediate-frequency circuit may be either of the untuned- or tuned-transformer variety and in which neutrodyne and reflexing may be employed to advantage.

This is not the receiver for the novice to attempt building, because a certain amount of familiarity with radio-frequency circuits is necessary.

During our recent visit to Princeton University, we inspected and operated, with Mr. Roberts, the completed receiver. To say that it tunes sharply would be putting it mildly, while its ease of operation is remarkable. There is a growing respect for the super-heterodyne, and we shall welcome information from those who experiment with the intermediate-frequency transformers along the lines outlined in this article.—THE EDITOR.

this rather sweeping statement, let us consider briefly the three most important features in any receiving set.

First, sensitivity: here nature, in the form of "static," spark sets and other interfering radio transmitters, imposes a limit to the useful sensitivity of any receiving set. For if the static and other interference coming in on the same wavelengths as the signal are stronger than the signal itself, then no amount of sensitivity will be of any use, for the undesired noises will always be louder than the signals. Thus, there is no sense in possessing a radio receiver that is any more sensitive than enough



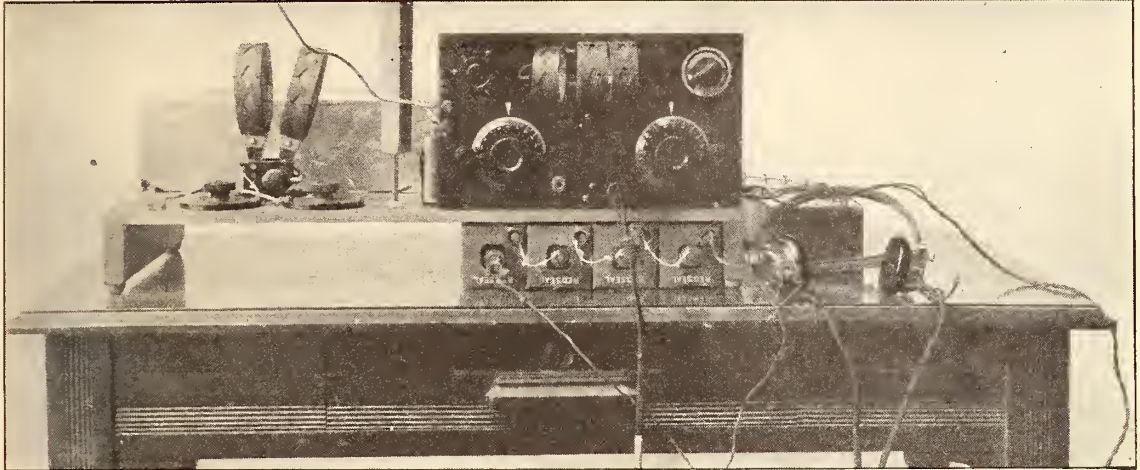

FRONT VIEW OF SUCCESSFUL SIX-TUBE SUPER-HETERODYNE BUILT BY MR. ROBERTS

The set uses two stages of intermediate-frequency amplification coupled by R. C. A. long-wave transformers, and one stage of A. F. amplification. The rheostat in upper left-hand corner of panel controls the volume, the left-hand condenser tunes the loop, and the right-hand condenser tunes the heterodyne

to bring in static and other noises with annoying loudness on the days when the interference is minimum. Any further increase in range will have to be obtained by the use of more power on the part of the transmitting stations.

Second, selectivity: here we have a very much more definite limit. To transmit music of high quality requires not a single frequency or wavelength, but a band of frequencies about 10,000 cycles wide. Thus, a station that advertises a concert "on 600 metres" will really be using all the wavelengths between about 594 and 606 metres, while a station transmitting on 300 metres will use all wavelengths between  $298\frac{1}{2}$  and  $301\frac{1}{2}$ . Hence the receiving set must receive these *bands* of wavelengths. If it is so selective as to receive only a narrower band, the quality of the received music suffers. On the other hand, if it is too "unselective" to eliminate signals on wavelengths outside of the necessary band, then there is just so much more opportunity for interference to get in. The ideal selectivity would be realized, of course, only when all wavelengths lying in the necessary band are received *equally* well and wavelengths outside the band are not received at all.

Third, ease of operation: only two controls should be necessary, one to select the station it is desired to hear, and the other to regulate the volume.

The super-heterodyne system can be made to meet all these requirements. There is very little trouble in getting all the sensitivity that is

desirable for working with a loop antenna. The selectivity can easily be made sufficiently close to the ideal, and by using what are called "band pass filters"<sup>1</sup> it could be made ideal; but this refinement hardly seems worth while. The controls are simple—one knob to control volume and two condensers to tune with. Here again, the ideal could be attained (if thought worth the trouble) by gearing or shafting the two condensers together so that turning a single knob would operate both condensers, the plates being cut to such shape that the relative values of the capacities would always be exactly correct. Or, almost as good, a single knob could turn two ordinary condensers so that they are approximately correct, and a small vernier condenser in parallel with one of them could be used to make the tuning exact after the station is picked up.

Having pointed out that the super-heterodyne method meets the most important requirements of a radio set better than any other

<sup>1</sup>A band-pass filter is an arrangement of capacities and inductances that allows almost uniformly free passage of all frequencies lying in a specified band, but almost completely prevents the passage of currents of any frequency lying outside this band. Band pass filters can be made successfully to pass a band of medium frequencies, but cannot be made to pass a narrow band of very high frequencies such as used in broadcasting. Hence they could not be employed directly in an ordinary receiving set, but if the super-heterodyne method is used, the intermediate-frequency amplification can be made to take place at a frequency sufficiently low so that a band pass filter could be constructed that would make the amplifier satisfy approximately the condition previously mentioned for ideal selectivity.

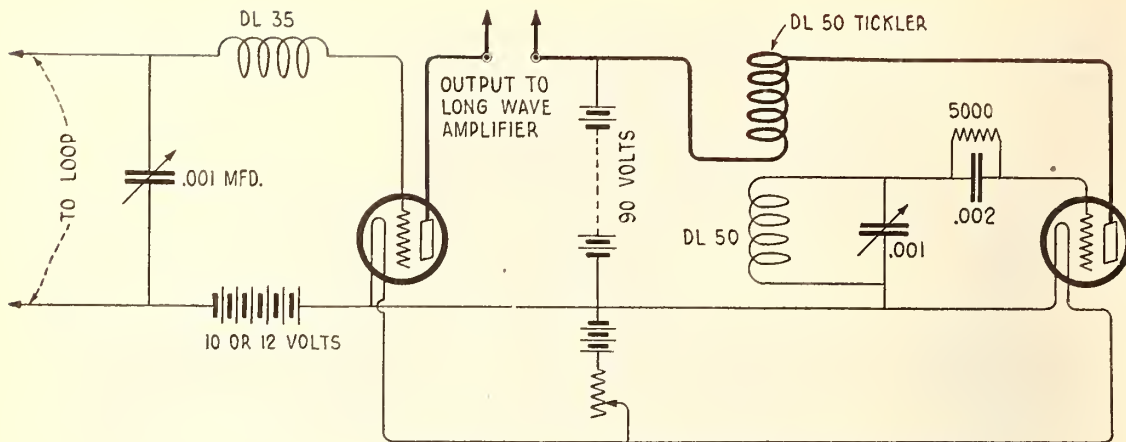

FIG. 1

The frequency changer is used to alter the incoming signals so that they may be put through a radio-frequency amplifier which operates on comparatively long waves

method in use at present, it will be well to describe this method briefly before going on to consider the actual circuits. The fundamental idea is supposed to have resulted from the following train of reasoning: a radio-frequency amplifier is comparatively easy to build for long wavelengths, but extremely difficult to make operate on short waves. But the signals to be received are on short waves. Then why not change the short-wave signals into long-wave signals? If this were done, long-wave radio frequency amplifiers could be used to receive them. Thus a super-heterodyne receiver really consists of two units, a frequency-changer and a long-wave receiving set. These two units are as distinct from one another as an ordinary radio set and the audio-frequency amplifier that is used with it. If you have a satisfactory frequency-changing unit, you can connect it up to any kind of long-wave amplifier and detector, or vice versa. It is to be hoped that in the future, radio apparatus makers will put out a first class long-wave amplifier-detector unit built to receive a fixed band of frequencies about 10,000 cycles wide. The amateur can then buy one of these and make his own frequency-changer to feed it, just as he may now buy a Western Electric 7A audio amplifier and builds his own radio receiver to feed it.

In the meantime, the amateur will have to experiment with his own make of long-wave amplifier, and it is the construction of this that presents the only difficult problem in making a super-heterodyne.

Returning to the frequency changer, its oper-

ation is as follows: if two voltages of different frequencies are simultaneously applied to the grid of a detector tube, then in the plate circuit of the tube will be found a number of currents of different frequencies, among these being a current whose frequency is equal to the *difference* between the two frequencies supplied to the grid.<sup>2</sup> Our frequency changer, then, is a detector tube having two frequencies supplied to it: first, the signal, which is picked up by a loop antenna, and second, a frequency supplied by a separate vacuum-tube oscillator, the "heterodyne," which feeds the detector tube by means of any suitable type of coupling. In the output of the frequency changer there will then be found a frequency which is equal to the difference between the signal frequency and the frequency of the heterodyne oscillator. By adjusting the heterodyne frequency, this difference may be made anything we please. The operation may be illustrated as follows: suppose we have a long-wave amplifier-detector unit that receives only waves of about 3,000 metres,

<sup>2</sup>Assuming that the plate-circuit current of the frequency-changer tube varies as  $(K + \text{grid potential})^2$  where  $K = \text{the "B" battery voltage} - \text{the "C" battery voltage}$  times the amplification constant of the tube, then if the incoming radio waves produce a voltage  $i_s \sin st$  upon the grid and the heterodyne oscillator impresses  $i_h \sin ht$  upon the grid at the same time, the plate current will be  $(k + i_s \sin st + i_h \sin ht)^2 = k^2 + i_s^2 \sin^2 st + i_h^2 \sin^2 ht + 2ki_s \sin st + 2ki_h \sin ht - \frac{1}{2}i_s i_h \cos(s+h)t + \frac{1}{2}i_s i_h \cos(s-h)t$ , by expanding and using a simple trigonometric reduction. It is the last term only that we are interested in, for it represents the current having a frequency equal to the difference between the signal and heterodyne frequencies. The coefficient  $\frac{1}{2} i_s i_h$  shows that the strength of this current is directly proportional to the strength of the voltage introduced by the heterodyne oscillator, hence the advantage of making this as great as possible.



which is a frequency of 100 kilocycles. Now suppose a signal is coming in at a wavelength of 400 metres, which is a frequency of 750 kilocycles. If we adjust the heterodyne tube to oscillate at a frequency of 850 kilocycles, then the difference between the heterodyne frequency and the signal frequency is 100 kilocycles, and this is just right to be fed to the long-wave amplifier. On the other hand, if the heterodyne oscillated at 650 cycles, the difference would again be 100 kilocycles. Thus there are always two possible settings for the condenser that adjusts the frequency of the heterodyne oscillator, either of which will bring in the same station. Sometimes it will be found better to use one than the other, but usually it makes no difference.

In building a frequency-changing unit, the chief points are: use as high a "B" battery voltage as available on both the frequency changing tube and the heterodyne; in the grid circuit of the heterodyne oscillator put a grid condenser and leak that will allow the tube to oscillate most strongly (say .002 mfd. or more and 500-ohm leak); in the grid circuit of the frequency-changing tube put an amount of "C" battery that can best be determined by experiment (if 90 volts of "B" battery are used, 10 or 12 volts of "C" battery will be about right); and, finally, adjust the coupling between the heterodyne oscillator and the frequency-changing tube so as to get plenty of the heterodyne frequency supplied to the frequency-changing tube. Up to a certain point, the more the better, because the output of the frequency-changer tube is proportional to the *product* of the signal and the heterodyne voltages.

Any sort of heterodyne oscillator circuit can

be used, and coupled, in any fashion. One convenient arrangement is the use of a three-coil honeycomb mounting which allows trying different coils and a great range of wavelengths to be received. These three coils are connected as shown in the circuit diagram, Fig. 1. The D. L. 35 and the tickler coils should be the movable ones.

As the only two adjustments in tuning are the two variable condensers here shown, it is well worth while to get the very best condensers for the purpose. The receiver tunes very sharply, and a list of stations with the exact settings of the condensers cannot be kept unless the construction is so rigid that a certain setting always gives the same capacity. For this reason it is inconvenient to use condensers with separate verniers. The General Radio condenser, with a small knob turning the condenser through a reduction gear, is completely satisfactory.

There should be no difficulty in building a good frequency-changing unit, and once made, it can be used without change in connection with any new or improved long-wave amplifier that may later be put on the market or described. The scheme, mentioned earlier in this article, of gearing the two condensers together so as to have only one knob to turn, is not recommended to the average constructor. Nature has given us two hands, and after a little practice it is not difficult to turn the two condensers simultaneously, keeping their relative values about right.

We now come to the more difficult unit to build, the long-wave amplifier. Before taking up the question of the *best* type, a very easy type to make will be described. The reason it

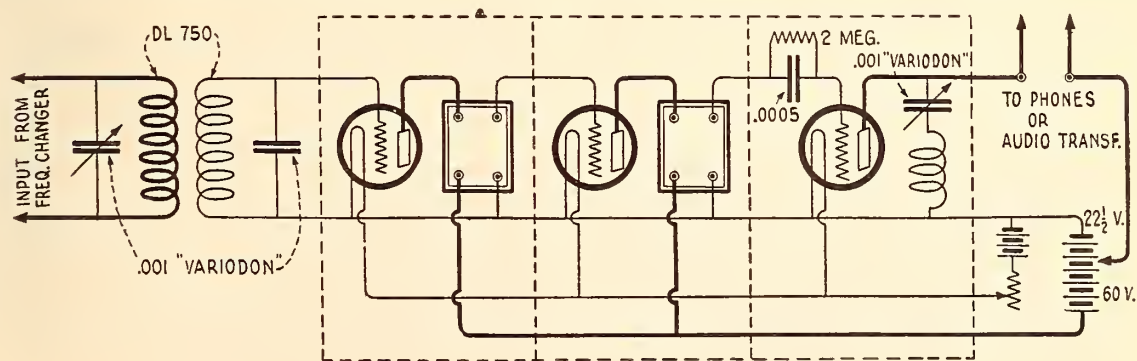
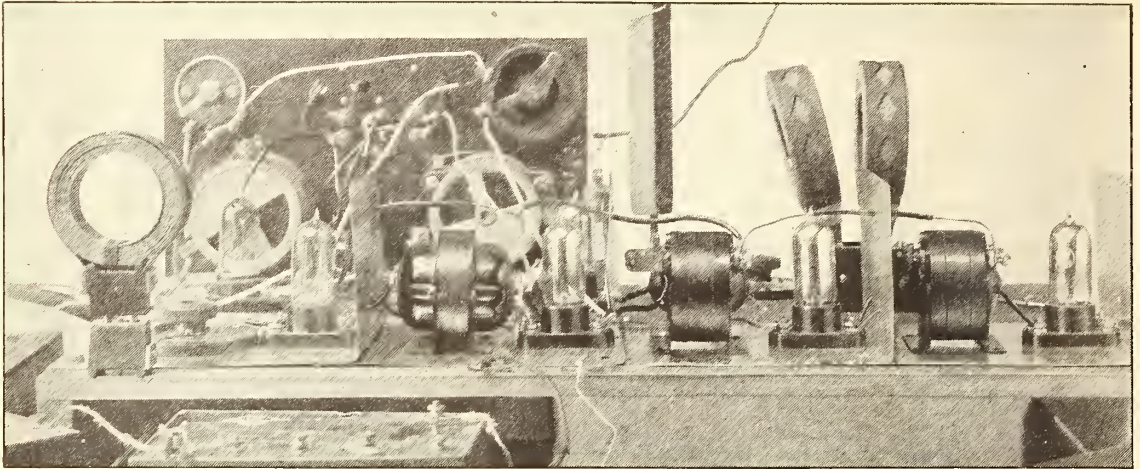

FIG. 2

The intermediate-frequency amplifier is coupled to the frequency changer by two DL750 coils shunted by .001 variable condensers. The amplifier itself is made with UV-1716 transformers and each stage is thoroughly shielded as shown by the dotted lines



REAR VIEW OF THE EXPERIMENTAL SUPER-HETERODYNE SET

The covers that complete the shielding are removed. At the extreme left is the inductance coil for the tuned shunt that by-passes the intermediate-frequency current, around the phones. This set runs on four new dry cells and 60 volts B battery, and operates a 10-D loud speaker very nicely for powerful stations up to about fifty miles away

is easy is because the transformers used are the Radio Corporation long-wave transformers and do not require tuning. The only precaution is to put some shielding between stages, preferably having each stage in a metal compartment (which however needs no top on it). In the circuit diagram, Fig. 2, the metal is indicated by the dotted lines and it will be noticed that the grid lead to each tube is as short as possible.

The loose coupling between the D. L. 750 coils gives the selectivity. Once the best tuning and coupling are found, this is never changed. The variable condenser and inductance in the compartment with the detector tube play a very important part in preventing the amplifier from howling. In most receiving sets there is a "by-pass" condenser to shunt the radio-frequency currents around the phones, but unless this capacity is very large, only a portion of the current is shunted. In the case of an amplifier working on a fixed frequency, however, this shunt circuit can be tuned so as to by-pass *all* the radio frequency, so that none of it gets outside the metal compartment and thus cannot get back to the input of the amplifier and cause howling. This device is especially necessary if any reflexing is to be done. An .001 "Variadon" condenser and a D. L. 750 coil will obviously tune to the right frequency, for this is the combination used to tune the input to the amplifier, but it would be better to use the smallest coil that can be tuned by the .001 condenser to the frequency used.

If the amplifier still howls in spite of this

tuned shunt, try reversing the connections to the primary of one of the radio-frequency transformers. Also try tuning the "Variodons" in the input to various frequencies. A setting can usually be found where the oscillations of the amplifier will stop. If not, something is wrong with the wiring, or a bad "B" battery is being used, or the leads to the "B" battery are too long.

#### RESULTS WITH 201-A'S

USING a frequency changer and long-wave receiver having the constants shown, and one stage of audio amplification with 6 volts of "C" battery on the grid of the audio amplifier tube and 90 on the plate, all six tubes being UV-201-A's, very good loud speaker results were obtained. Stations up to 100 miles away were received loudly enough in day time to be heard all over a fair-sized room, using a Western Electric 10-D loud speaker. At night the sensitivity was good enough to allow stations as far west as KHJ and KF1 in California to be heard on the loud speaker (from Princeton, N. J.), and others not so far but of lower power and hence even more difficult to pick up. As a result of the work with this amplifier, it was concluded that with UV-201-A tubes, if everything is made to work its best, two stages of intermediate-frequency amplification is all there is any practical use for. Another stage could, of course, have been put in and the amplification cut down to the desired amount by a device such as will be described later.



THE UV-199 TUBE

THE receiver just described is well within the ability of the average constructor to duplicate and perhaps improve upon. More experienced radio fans may, however, like to tackle the proposition of making a set to run on dry cells. Assuming that six Radiotron UV-199's are used, they can be arranged in three groups, each group having the filaments in series. Thus only 180 milliamperes will be required and can be supplied by 5 dry cells in series, with a 10-ohm rheostat that can be cut out as the dry cells run down. The heterodyne tube and the frequency-changing tube can have their filaments in series, and the final detector and the first intermediate-frequency tube are also in series. Three stages of radio-frequency amplification are required because the output of the frequency changer as well as the amplification per stage will be less when using 199's than with 201-A's. To get the most out of the tubes, a stage of audio can be added by reflexing back to one of the radio-frequency amplifier tubes. To get the most out of each stage of radio-frequency amplifier tubes, transformers should be used that match the impedance of the 199 tube, and at the same time supply the necessary selectivity. Four tuned transformers will give too great an overall selectivity for good quality if very long waves are used, so that it is better to use a fairly high intermediate frequency, and this in turn will probably render necessary the use of the "neutrodyne" system for the prevention of regeneration due to the internal capacity of the tubes. This is in addition to shielding each stage as well as possible by putting each in a separate metal compart-

ment. Finally, the loudness of the signals can be controlled by a rheostat of about 50 ohms in series with the filaments of either pair of tubes in the intermediate-frequency unit. If the audio current is reflexed back to the first tube in this unit, then the above mentioned rheostat should control the filament currents in the second and third tubes, while if the audio is reflexed back through the second or third tubes, the rheostat should control the filament current through the first tube and detector. Thus the tube doing the audio-frequency amplifying will always have its filament current up to normal, and the quality will not be affected by cutting in the control resistance. The advantage of reflexing back to the first tube is that it is the one least "loaded" by the high frequency, while the disadvantage is that any feed-back is more likely to make the amplifier regenerate or oscillate. It is of course possible to obtain two stages of audio amplification by the "inverse duplex" arrangement, but even if the difficulty of keeping the amplifier stable is overcome, the quality is likely to suffer, and one stage is sufficient when working with the head set.

A receiver built upon the foregoing plan (see Fig. 3 and photos) was built by the author at Princeton and has been used for a week or so with very good results. Although June is not a very good month for long-distance work, Chicago stations are heard regularly at night, and several other fairly distant ones have been heard, notably 6KW in Cuba, a low-powered set. The operation of the set is a pleasure. The two condensers have to be set just right, and if both of them are moved even a degree or so, loud local stations drop out of hearing

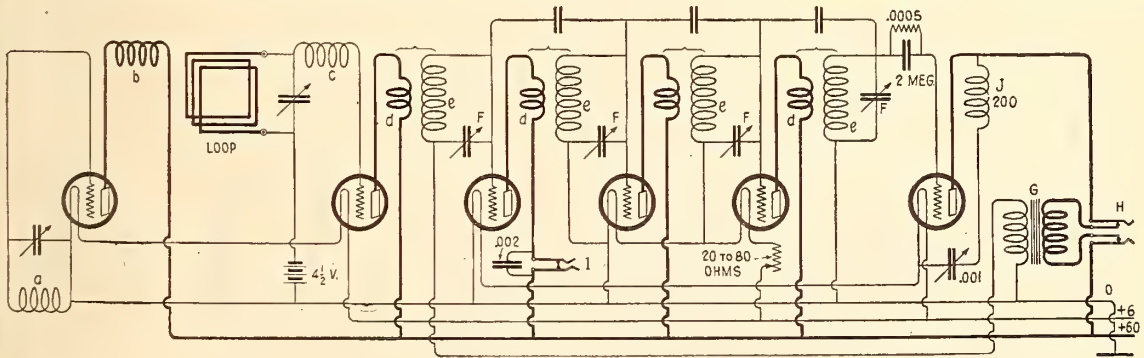

FIG. 3

The circuit diagram for the complete receiver built and used by Mr. Roberts. a and b = DL50 coils; c = DL35; d = 70-turn coil of 32 D.C. wire on the tube inside e; e = DL250; F = Variodons; G = audio transformer; H = closed-circuit jack; I = open-circuit jack; J = DL200

completely. The amplifier is very stable, whether one is listening in on the detector or with the stage of audio amplification, and the 80-ohm rheostat controls the volume perfectly. However, the sensitivity can probably be much improved by perfecting the design of the R. F. transformers. The ones in use at present have a secondary consisting of a 250 D. L. coil tuned by an .0004 Variadon. The primary is about 70 turns of 32 D. C. C. wire wound on a cardboard mailing tube of such size that the primary fits snugly inside the D. L. 250 coil. The connections are such that current entering the primary from the plate circulates in a direction opposite to that of current entering the secondary from the grid. This is necessary to "neutrodyne." This design was the only one tried, and probably can be considerably improved. In putting the set in operation, the steps are as follows: start with all the neutrodyning capacities obviously too great—using, say, pennies about  $\frac{1}{4}$  inch apart. Set all the secondary condensers to the same values. Listen in on the detector and pick up some loud local station. Then leaving the two condensers in the frequency changer, alone, go over all the condensers in the intermediate-frequency amplifier and get the best setting for each. Then reduce the neutrodyning

capacities to a point just above regeneration (with 199 tubes no neutrodyne capacity at all is absolutely necessary for the lower frequencies). Finally, plug into the audio-amplifier output and adjust the tuning of the shunt between the detector plate and filament so that there is no tendency for the set to oscillate. The set should now be working satisfactorily. After using it a few days so as to know about how sensitive it is, try using a different intermediate frequency by changing all the condensers across the transformer secondaries in that circuit and going through the same process. In this fashion the best frequency to work at will be found. There will probably not be a great deal of difference.

The foregoing hints have been given in a rather sketchy fashion because it is assumed that any one competent to improve upon the transformers will not require a more detailed description. After further experiments which he intends to make, if the writer hits upon a transformer design that completely satisfies him, an exact description of it will be given; so that any one with good mechanical ability will be able to build himself this six-tube dry-cell receiver that has all the advantages of the superheterodyne control, the neutrodyne type amplifier, and the "reflex" system, rolled into one.

## A New Regenerative Radio-Frequency Combination

By ROGER A. WEAVER

**W**HILE experimenting with regenerative receivers for operation on ground circuits, a broadcast fan developed a circuit with remarkable possibilities. One of the original models of the apparatus was made in the office of the editor of RADIO BROADCAST, and in initial tests, signals were received from Calgary, Alberta, without any antenna and using a steam pipe ground system for intercepting the ether waves.

During the remainder of the summer, Mr. Wagner and Mr. Lynch carried on extensive experimental work, constructing various models of receivers. In the fall of 1922, Mr. A. H. Grebe became interested in these experiments

and shortly after that time Mr. Wagner joined the engineering staff of A. H. Grebe & Co., Inc., for the purpose of developing the new receiver.

After some months of experimenting, a receiver was built fulfilling every requirement for long range, adaptability, and simplicity of operation.

As may be seen from the accompanying illustrations, the receiver is entirely self-contained, except for the loud speaker, and a 20-ft length of silk-covered wire which is used for the aerial. This wire may be concealed beneath the carpet or run along the picture molding. There are separate rheostat controls for each tube, and switches are provided for





## When you build your own

**H**ALF the fun of radio is in building your own set, as every amateur who has made one knows. And when you buy a panel, of course you want the best. You can construct a neat, attractive set that looks like a professional job when you use Celoron Radio Panels.

Celoron panels are handsomely finished, are easy to machine, and will engrave evenly without feathering. The high dielectric strength, uniformity, and superior insulating qualities of Celoron make it the ideal material for radio panels.

### *Buy them ready-cut*

Celoron Radio Panels come ready-cut in standard sizes. Each panel is wrapped separately in glassine paper.

Ask your radio dealer for one of the following standard sizes:

- |                           |                             |
|---------------------------|-----------------------------|
| 1.—6 x 7 x $\frac{1}{8}$  | 4.—7 x 18 x $\frac{3}{16}$  |
| 2.—7 x 9 x $\frac{1}{8}$  | 5.—9 x 14 x $\frac{3}{16}$  |
| 3.—7 x 12 x $\frac{1}{8}$ | 6.—7 x 21 x $\frac{3}{16}$  |
|                           | 7.—12 x 14 x $\frac{3}{16}$ |

If your dealer has not yet stocked these panels, get him to order for you; or write direct to us, designating by number the size you want. Celoron is also made in full-size sheets, and we can furnish panels in any sizes desired.

### *This booklet free*

Our booklet, "Tuning in on a New World," contains a list of the leading broadcasting stations in the United States and Canada, several efficient hook-ups, and an explanation of the symbols used in radio diagrams. This booklet will be sent free on request. Just drop us a line.

## Diamond State Fibre Company

BRIDGEPORT

(near Philadelphia)

PENNSYLVANIA

Offices in Principal Cities

In Canada: Diamond State Fibre Co. of Canada, Limited, 245 Carlaw Ave., Toronto

**To radio dealers:** Celoron Radio Panels cut in standard sizes offer an exceptional opportunity for quick sales and substantial profit. Write for special dealer price list showing standard assortments.

★ CONDENSITE  
**CELORON**  
 STANDARD RADIO PANEL

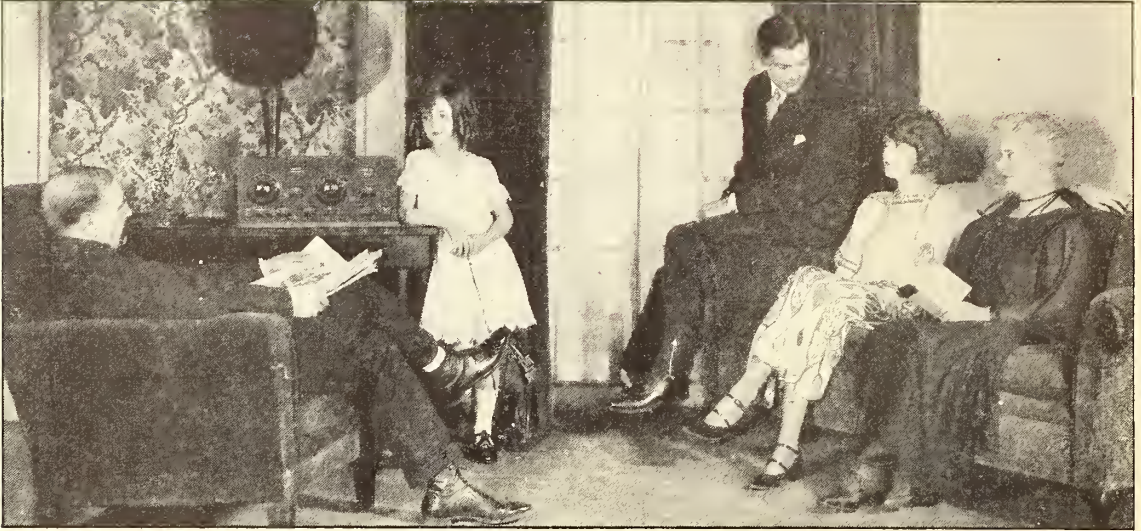

changing the rheostat range from either 0-5 or 0-50 ohms. This permits the use of any desired combination of tubes, from UV-199, which consumes but 60 milliamperes to the 201's which may draw as high as one ampere. Of course, it is expected that the receiver will be used with dry-battery tubes, and compartments have been provided for both filament and plate batteries.

An operating switch located on the lower right corner of the panel controls the filament and output circuits in such a manner that when this switch is pulled all the way out, all four tubes are lighted, and when the switch is pulled but half way out only three tubes are lighted. With the switch in the latter condition, the set may be used with head telephones for dis-

tant reception, or with a loud speaker for local reception. An "Aerial Switch," located at the extreme left of the panel, controls a set of small mica condensers which are necessary to provide for the variation in wavelength range incident to the use of the set in various locations. Under all circumstances, it is possible by means of this switch to tune in the complete wavelength range of 200 to 600 meters. For the direct control of wavelength, two dials with the usual Grebe tangent wheel verniers are used. One of these, the "Secondary Wavelength Dial," is calibrated directly in wavelengths, thus facilitating speed and accuracy in tuning to distant stations of known wavelength but low audibility. Tuning of the primary circuit is accomplished with a similar dial, while the control of regeneration is effected through the movement of the small tangent wheel centrally located between the wavelength dials.

A feature well worthy of mention is the manner in which two or more of these receivers operate in close proximity of one another. Three of these receivers were installed in one room, and operated simultaneously without any material effect of reradiation being noticeable. For example, it was possible to tune in one set to WEA, and then proceed to tune the second and third sets to the same wavelength without causing a disturbance.

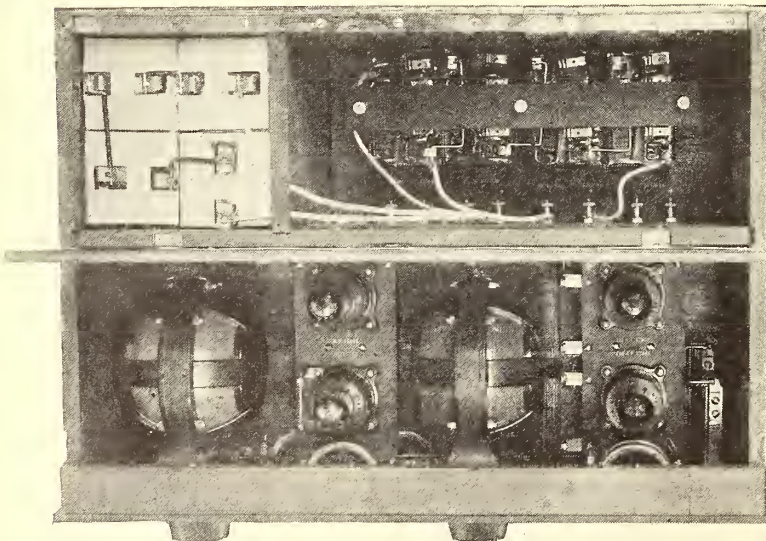





THE man who purchases a Magnavox for its *clearness* of reproduction, finds additional advantages in its use which contribute greatly to his enjoyment of Radio.

For instance, due to its extreme sensitivity, the Magnavox can reproduce distant signals which to ordinary reproducers would be indistinguishable. Ask your dealer for a demonstration.

Magnavox R2 Reproducer and 2 stage Power Amplifier (as illustrated) \$115.00

R2 Magnavox Reproducer with 18-inch horn: the utmost in amplifying power; requires only .6 of an ampere for the field . . . . . \$60.00

R3 Magnavox Reproducer with 14-inch curvex horn: ideal for homes, offices, etc. . . . . \$35.00

Model C Magnavox Power Amplifier insures getting the largest possible power input for your Magnavox Reproducer  
2 stage \$55.00  
3 stage 75.00

*Magnavox Products can be had from good dealers everywhere. Write for new booklet.*

**THE MAGNAVOX COMPANY**  
Oakland, California

New York Office: 370 Seventh Avenue

# MAGNAVOX PRODUCTS

No Radio Receiving Set is complete without them



# The Grid

## QUESTIONS AND ANSWERS

The Grid is a Question and Answer Department maintained especially for the radio amateurs. Full answers will be given wherever possible. In answering questions, those of a like nature will be grouped together and answered by one article. Every effort will be made to keep the answers simple and direct, yet fully self-explanatory. Questions should be addressed to Editor, "The Grid," RADIO BROADCAST, Garden City, N. Y.

### SUMMER RECEIVING CONDITIONS AND THE IDEAL SET

*During the last two months my receiving set has become comparatively inoperative. During the winter I was able to hear stations as far west as Davenport, Iowa. I also heard Havana on several occasions, many stations in the southern states, to say nothing of several Canadian broadcasters. Now I am able to receive nothing farther away than five hundred miles, and most of my evenings are spent listening to WGY, WEA, WOR, KDKA and WJZ, all comparatively near, and who (especially WGY and KDKA) do not come in with anything like their former loudness. My set has not been changed in over eight months, excepting batteries, and, thinking that the fault might be in the antenna, I recently erected a new one without improving matters.*

*My set has also developed a crackling which even the most careful investigation of connections and batteries has been unable to eliminate in the slightest degree.*

*Can you give me any idea as to what is wrong with my apparatus?*

R. L. S., NUTLEY, N. J.

THAT the thousands who have become broadcast enthusiasts during the past winter have yet to learn the radio significance of summer, is evident from many letters similar to the above which have recently been addressed to this department. The plaint of our correspondent is as old as the wireless game itself, and it emphasizes a field of radio endeavor that has yet to capitulate to science.

Reception drops off, to a very appreciable extent, in the warm months, and it is often less than fifty per cent. as efficient as during the cold, clear winter nights. The crackling noise of which the writer speaks is "static," without a doubt. The sound will probably cease with the discon-

nection of the antenna, proving that it is due to "X's" or "strays" which the radio world for twenty years has sought to eliminate.

Unless the enthusiast is willing to alter his apparatus so as to conform with the requirements of summer reception, he must bow to these conditions as inevitable. However, the addition of radio-frequency amplification to apparatus operating from an open antenna will bring back the distance reception which was possible on fewer tubes during the winter. Two stages, or at the most, three, of transformer-coupled R.F., or sometimes a single stage of a correctly installed and operated tuned-plate amplifier, will suffice to accomplish this. Radio-frequency amplification will also, to an extent, reduce the effect of static, and in no case will the static be appreciably amplified. This is due to the limiting effect of R. F., as well as to its discrimination against all frequencies other than that to which the amplifier is tuned. Static disturbances, incidentally, are much more noticeable and prevalent on the higher waves.

Static can be practically eliminated by receiving on loop, using the requisite R. F. amplification, reception often being possible in the midst of a thunder storm. Ambitious experimenters will do well to arrange an R. F. set that may be thrown from open aerial to loop antenna, thus insuring fairly consistent reception throughout the summer, regardless of atmospheric conditions. Such a circuit, with the suggested switching arrangement, is shown in Fig. 1. The construction of a suitable loop antenna was described in the June, 1923, GRID.

### INTERFERENCE AND FADING CAUSED BY A NEAR-BY SET

*I have a two-stage regenerative set which is the same as owned by my next door neighbors. When I am tuned in on a*

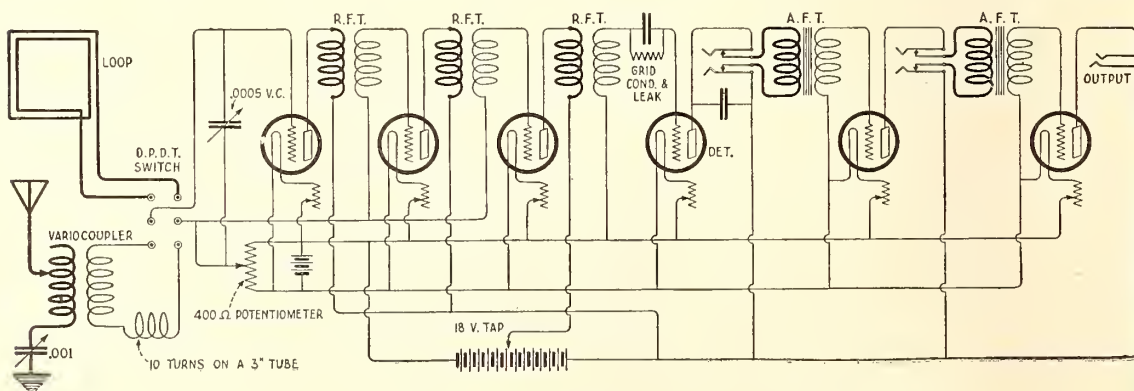

FIG. 1



# Out of Door's with a Portable Radiola

## RADIOLA II

Take it along—up to the mountains—out to the beach. On every auto trip and every camping trip.

Throw an insulated wire over a tree. That's all the antenna you need. Attach a ground wire to a bit of pipe in the earth, or a house pipe indoors. That's all the installation you need.

When it's home, the portable Radiola is a fine piece of furniture, of rich mahogany finish. When it's out-o'-doors, it's an easy-to-carry set, with a handle to carry it by, and all its batteries tucked away inside it. Two tubes give it power to hear over long distances—or to operate on a loud speaker over short distances.



**RADIOLA II** with two Radiotrons UV-199, all batteries and pair of headphones: \$97.50.

*This symbol of quality is your protection*



*"There's a Radiola for every purse"*

At the nearest Radio or Electrical Store

**Radio Corporation of America**

*Sales Department*  
233 Broadway, New York

*District Sales Offices*  
10 So. LaSalle St., Chicago, Ill.  
433 California St., San Francisco, Cal.

# Radiola

REG. U. S. PAT. OFF.

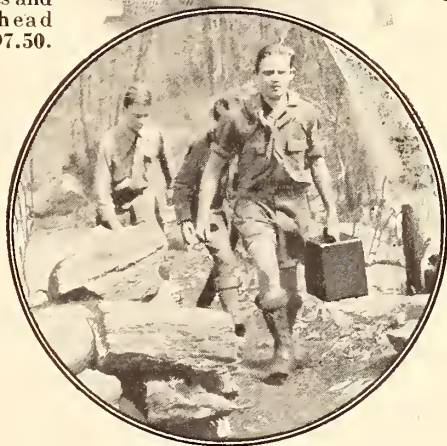

**Radio Corporation of America**  
Dept. 2066 (address nearest office listed)

Please send me your free Radio Booklet describing sets from \$25 to \$350.

Name \_\_\_\_\_  
Street Address \_\_\_\_\_  
City \_\_\_\_\_ R. F. D. \_\_\_\_\_  
State \_\_\_\_\_

★ Tested and approved by RADIO BROADCAST ★

## Radio Broadcast

station and they tune in, it causes a lot of noise and lessens the strength of my signals. Our aerials are about twenty feet apart. There is a two-wire antenna, 125 feet long, while mine is a single-strand, 160 feet long, strung about five feet lower than theirs.

*Is there any way of overcoming this interference?*

K. B. WILKES-BARRE, PA.

JUDGING from the results, the probability is that the two stations in question are using single-circuit regenerative sets, and the above is a fair example of the difficulties to which the too general adoption of apparatus of this type has given rise. Though the antennas in this case are unusually close together, the same condition is found in many congested radio districts.

The noise is doubtless a heterodyne caused by the interaction of the individual oscillations set up in each antenna during the process of tuning, or the conjunction of one or both with the broadcasting wave.

The undesirable effects can doubtless be greatly reduced by running the two aerials at right angles to each other. However, as it is almost impossible to tune a single-circuit receiver without throwing it into an oscillating state, the disturbances can be totally eliminated only by a complete change in equipment at both stations. RADIO BROADCAST recommends a receiver of the primary, secondary, and tickler type operated with loose coupling, or a variocoupler and twin-variometer regenerator. These receivers radiate comparatively weak oscillations, and are more selective than the single-circuit sets.

## Supplemental List of Broadcasting Stations in the United States

LICENSED FROM MAY 18 TO JUNE 15 INCLUSIVE

CALL SIGNAL	STATION	FREQUENCY (Kilocycles)	WAVE-LENGTH
KFHP	Radio-Bug Products Co., Kearney, Nebr.	1220	246
KFHQ	Curtis Bros. Hardware Store, Los Gatos, Calif.	1240	242
KFHS	Dow, Clifford J., Lihue, Hawaii	1090	275
KFIJ	Sidney I. Thorean, Platte, S. Dak.	1270	236
KFIK	Gladbrook Electrical Co., Gladbrook, Iowa	1280	234
KFIL	Windisch Elect. Farm Equipt. Co., Louisburg, Kansas	1280	234
KFIO	North Central High School, Spokane, Wash.	1190	252
KFJA	Central Power Co., Grand Island, Neb.	1230	244
KFJB	Marshall Elect. Co., Marshalltown, Iowa	1210	248
KFJD	Weld County Printing & Publishing Co., Greeley, Colo.	1270	236
KFKA	Colorado State Teachers College, Greeley, Colo.	1210	248
KFKH	Denver Park & Amusement Co., Lakeside, Colo.	1330	226
KFLE	National Educational Service, Denver, Colo.	1120	268
WABI	Bangor Railway & Electric Co., Bangor Me.	1250	240
WABJ	The Radio Laboratories, South Bend, Ind.	1250	240
WABK	First Baptist Church, Worcester, Mass.	1190	252
WABL	Connecticut Agri. College, Storrs, Conn.	1060	283
WABM	Doherty, F. E., Saginaw, Mich.	1180	254
WABN	Grover, Waldo C., La Crosse, Wis.	1280	234
WABO	Lake Avenue Baptist Church, Rochester, N. Y.	1190	252
WCBA	Charles W. Heimbach, Allentown, Pa.	1070	280
WBBD	Barbey Battery Service, Reading, Pa.	1280	234
WCBD	Voliva, Wilber Glenn, Zion, Ill.	870	345
WDDB	Kirk Johnson & Co., Inc., Lancaster, Pa.	1160	258
WDBF	Phillips, Robert G., Youngstown, Ohio	1150	261
WJY	Radio Corporation of America, New York, N. Y.	740	405
WJZ	Radio Corporation of America, New York, N. Y.	660	455
WRAW	Good, Horace D., Reading, Pa.	1260	238
WRAX	Flexon's Garage, Gloucester City, N. J.	1120	268
WSAD	J. A. Foster Co., Providence, R. I.	1150	261
WTAG	Kern Music Co., Providence, R. I.	1160	258
WTAK	Swan-Bower Co., The, Steubenville, Ohio.	1130	266

### DELETIONS FROM MAY 1 TO MAY 30

KDN	San Francisco, Calif.	WAAQ	Greenwich, Conn.
KDZH	Fresno, Calif.	WAAS	Decatur, Ga.
KFAZ	Reedley, Calif.	WDAC	Springfield, Ill.
KFCQ	Casper, Wyo.	WEAT	Tampa, Fla.
KFGF	Mount Vernon, Wash.	WFAU	Boston, Mass.
KFGM	Abilene, Tex.	WGAD	Ensenada, P. R.
KFHC	Norman, Okla.	WGAH	New Haven, Conn.
KFV	Yakima, Wash.	WGAJ	Shenandoah, Iowa
KLB	Pasadena, Calif.	WHAR	Atlantic City, N. J.
KOY	Portland, Oreg.	WJZ	Newark, N. J.
KYI	Bakersfield, Calif.	WPA	Fort Worth, Tex.
KYJ	Los Angeles, Calif.	WPM	Washington, D. C.
WAAJ	Boston, Mass.	WVAJ	Columbus, Ohio.



10,000 Miles of Radio Lectures in China

# RADIO BROADCAST

Prize-Winning Hookups

Set-Backs and Come-Backs at 6KW

How Vacuum Tubes are Made

Notes on Tuned Circuits

What You Should Know  
about Condensers



25  
Cents

September, 1923

Published by

DOUBLEDAY, PAGE & CO.

Garden City, N. Y.

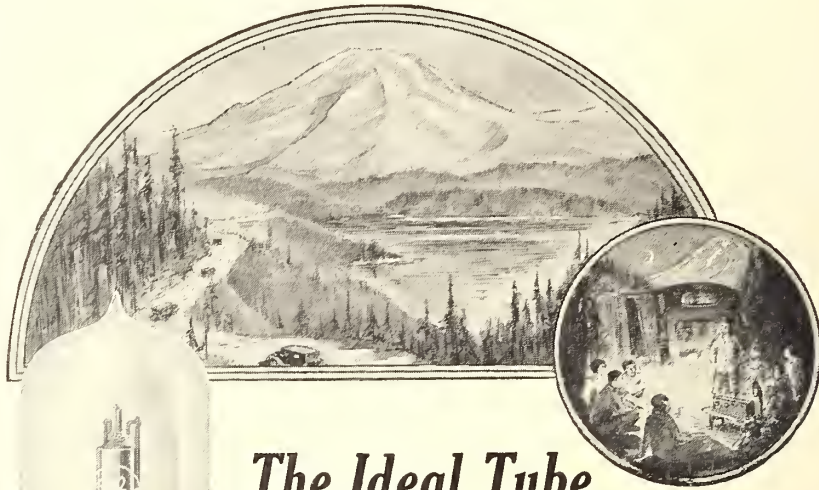

## The Ideal Tube For the Call of the Open

Are you spending your vacation in the North Woods—at the seashore—in one of our many great national parks, or are you motoring across country? In any event the new Cunningham dry battery detector and amplifier, type C-299, makes it possible for you to take a radio receiver, which will be light in weight, compact in design, and highly efficient in operation. It is the special filament in this tube, having a current so low that it may receive its supply from standard No. 6 dry batteries or even from ordinary flashlight batteries, that makes possible this new and interesting application of radio.

*A Specially  
Designed Tube  
For Every  
Radio Use*

The receiving set you now have can be readily adjusted to use this new tube and be a source of use and pleasure on your vacation trip. In any event your dealer can give you useful suggestions for the purchase or construction of a highly efficient and practical portable set.



**Patent Notice:** *Cunningham tubes are covered by patents dated 11-7-05, 1-15-07, 2-18-08, and others issued and pending. Licensed for amateur, experimental and entertainment use in radio communication. Any other use will be an infringement.*

*E. J. Cunningham Inc.*

**Home Office:**  
248 First Street  
San Francisco, Calif.

**Eastern Representative:**  
Chicago, Illinois

★ Tested and approved by RADIO BROADCAST ★



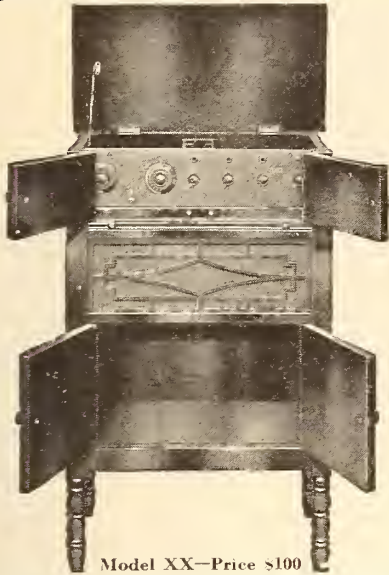

Model XX—Price \$100

A four tube set in a beautiful, upright, mahogany finished cabinet. The hinged lid and doors give easy access to any part of the receiving apparatus. The lower compartment is for batteries.



Model VI—Price \$28.00

This Model contains the stage of tuned radio frequency amplification brought to 100% perfection by the Crosley Co. For its price and size, it gives surprising results in long range reception. Hundreds of testimonials have paid tribute to its efficiency.

Crosley  
Type "D" Condenser—\$2.25

The wonderful efficiency of this new condenser has caused its popularity to grow rapidly. It increases the efficiency of your Crosley receiving set, notwithstanding its own conventional form and that it is different from the old interlocking plate type.

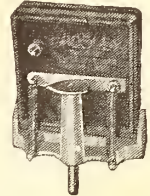

New Crosley Socket—50c

A smaller and neater socket now replaces the old porcelain one. It has the unique feature of base and panel mounting found only in Crosley sockets. (Patent pending). It fits perfectly and has the highest dielectric qualities.

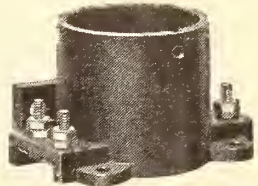

New Crosley Multistat—80c

This multistat, of from 0 to 20 ohms resistance, will take care of all types of tubes with its high and low resistance wire. This unit solves the problem of filament control on different tubes. The smooth running, ball bearing contact is continued.



For Sale by Best Dealers Everywhere

Free Catalogue on Request

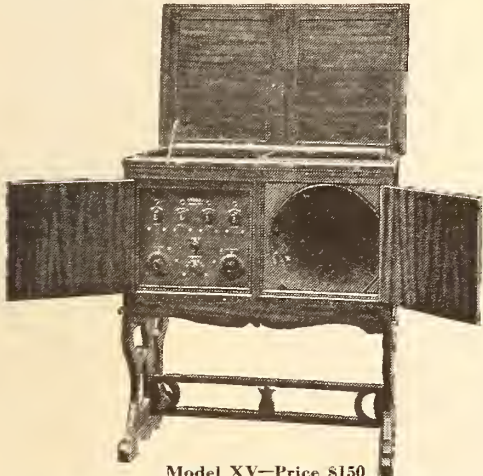

Model XV—Price \$150

A console cabinet model which is a combination of efficiency and beauty. This is designed for homes and clubs where a complete, long-distance set is required. Equipped with compartment for batteries and loud speaker.



# CROSLEY

Better - Cost Less  
Radio Products

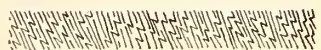
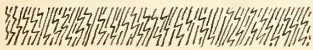

★ Tested and approved by RADIO BROADCAST ★

# Radio Broadcast

ARTHUR H. LYNCH, EDITOR



## CONTENTS FOR SEPTEMBER, 1923

"Hearin' Things at Night" - - - - -	Frontispiece
THE MARCH OF RADIO - - - - -	J. H. M. 359
SET-BACKS AND COME-BACKS AT 6KW - - - - -	FRANK H. JONES 368
PAPERS OF THE RADIO CLUB OF AMERICA, II	
The Thoriated Tungsten Filament - - - - -	W. C. WHITE 375
10,000 MILES OF RADIO LECTURES IN CHINA - -	CHARLES H. ROBERTSON 382
WANTED: A DESERT ISLAND! - - - - -	ZEH BOUCK 391
HOW VACUUM TUBES ARE MADE - - - - -	W. W. RODGERS 397
SOME NOTES ON TUNED CIRCUITS - - - - -	M. B. SLEEPER 404
A LITTLE FORESIGHT AND A BIG SUCCESS - - -	ALFRED M. CADDELL 406
HIGHLIGHTS IN THE HISTORY OF WDAP - - - -	J. ELLIOTT JENKINS 411
"MUSIC HATH CHARMS—" - - - - -	415
RECEIVING CONTEST WINNERS - - - - -	416
In Tune with the Infinite - - - - -	ERIC G. SHALKHAUSER ( <i>Second Prize</i> ) 417
Hearing North America - - - - -	MISS ABBYE M. WHITE ( <i>Third Prize</i> ) 421
The World at Your Finger Tips - - - - -	H. BLUMENFELD ( <i>Fourth Prize</i> ) 426
BROADCASTERS IN NEW YORK, PARIS, AND LOS ANGELES - - - - -	429
WHAT YOU SHOULD KNOW ABOUT CONDENSERS, I -	ALLEN D. CARDWELL 430
THE GRID—QUESTIONS AND ANSWERS - - - - -	435
ADDITIONAL BROADCASTING STATIONS IN THE UNITED STATES - - -	438
NEW EQUIPMENT - - - - -	440
AMONG OUR AUTHORS - - - - -	442

Copyright, 1923, by Doubleday, Page & Co. All rights reserved  
TERMS: \$3.00 a year; single copies 25 cents

F. N. DOUBLEDAY, Pres.

RUSSELL DOUBLEDAY, Sec'y.

ARTHUR W. PAGE, Vice-Pres.

S. A. EVERITT, Treas.

NELSON DOUBLEDAY, Vice-Pres.

JOHN J. HESSIAN, Asst. Treas.

DOUBLEDAY, PAGE & CO.

THE WORLD'S WORK

COUNTRY LIFE

THE GARDEN MAGAZINE

SHORT STORIES

EDUCATIONAL REVIEW

CHICAGO, People's Gas Bldg.

GARDEN CITY, N. Y.

NEW YORK: 120 W. 32nd Street

BOSTON: Tremont Bldg.

LOS ANGELES: Van Nuys Bldg.



**Radiotron  
UV-201-A**  
The super-amplifier  
tube \$6.50



**Radiotron UV-199**  
The little tube of big  
performance \$6.50



**Radiotron UV-200**  
The long distance de-  
tector \$5.00



**Radiotron WD-11**  
The ideal dry battery  
detector \$6.50



**Radiotron  
WD-12**  
The standard base  
dry cell tube  
\$6.50



This symbol  
of quality is  
your protec-  
tion



# Radiotrons

## To Get Distance— and Get it Clearly

For quality of reception and length of service, every fellow wants a RADIOTRON. Experienced amateurs and broadcast listeners know the sensitivity and dependable performance of these tubes. UV-199 for portable sets because it operates on flashlight batteries, WD-11 and WD-12, the dry cell tubes, for use everywhere—especially on farms and at the summer bungalow—UV-200 and UV-201-A for use with a storage battery. There is a Radiotron for every need.

Look for the RCA trade mark, and the name RADIOTRON. Each is a guarantee of satisfaction.

**Radio Corporation of America**

Sales Dept., Suite 2066  
233 Broadway, New York

District Sales Offices

10 So. LaSalle St.  
Chicago, Ill.

433 California St.  
San Francisco, Cal.

# Radiotrons

REG. U. S. PAT. OFF.

★ Tested and approved by RADIO BROADCAST ★





Photograph by Roger B. Whitman

“HEARIN’ THINGS AT NIGHT”

This clearing in the woods was filled with music from a four-tube reflex receiver perched on a tree-stump. The Scouts are members of Troop 55, Garden City, L. I.



# RADIO BROADCAST

Vol. 3 No. 5



September, 1923

## The March of Radio

### PRESIDENT HARDING OVER WIRE AND RADIO

**T**HE coöperation of wire and radio is undoubtedly a development which will prove of inestimable importance in putting the vast multitudes of this country in close touch with its important events. Many important happenings occur where there is no radio station, events which cannot be brought to the studio. But few and far between are the events which the telephone engineer cannot reach, if the occasion demands. The vast network of wires throughout the country is of such fine mesh that few places where anything important is likely to happen are more than a few miles from wire connection. With a good wire connection, the distant radio station is enabled to broadcast its message almost as well as if the event transpired in the studio.

We said "a good wire connection," and this means more than the average reader probably surmises. The ordinary telephone and telegraph wires are entirely unsuited for sending the voice currents to the broadcasting station. Their transmission is much too poor in quality, and in addition they pick up much extraneous "electrical noise." The engineers of the American Telephone and Telegraph Company have studied this problem in its most minute details: both theoretically and experimentally the staff has attacked the question as to what good voice transmission really is, and how to get it. They can tell you all about the different "energy levels" of

noise and voice currents for different kinds of telephone lines, and they have found out that only the highest grade telephone lines may be used in their long-distance, transcontinental circuits. Even these best quality lines must be improved before they are suitable for carrying the voice currents to a broadcasting station. The wires must be "balanced" to get rid of disturbing noises, fitted with "repeaters" which will amplify the voice currents and yet keep the original quality of the voice unimpaired, and equipped with duplicate apparatus to ensure continuity of service. All these items are being worked out in such a way that before long the telephone company will have a network of high grade "radio wires" available for operating the various broadcasting stations it will probably erect.

An excellent test and illustration of the value of this service was recently given when President Harding's speech was sent from St. Louis to New York, and there broadcasted from station WEAJ. The voice currents had to travel about a thousand miles before actuating the control of the radio transmitter, yet the articulation was excellent, considering the long route taken by the voice before it reached the listener-in.

This is one of the marvels which radio engineers, with vision, have been predicting for a year or two—the President addressing his countrymen—not a few hundred or thousand in the most capacious hall obtainable,

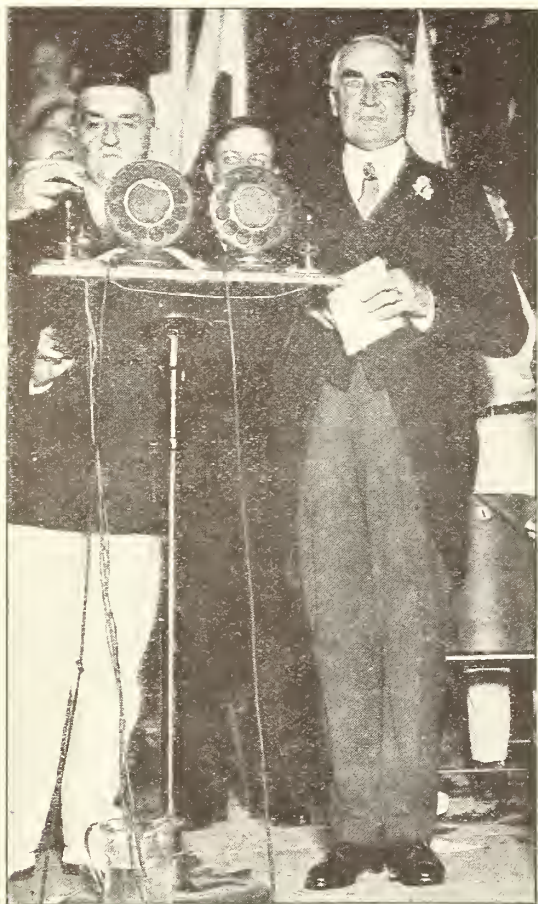

#### SPEAKING TO THE NATION FROM ST. LOUIS

In his address of June 21st at the St. Louis Coliseum, President Harding said: "It has seemed to me that nearly every city and village, from the Potomac to the Pacific, has bestowed an invitation and a tender of hospitality. I would like to say to you, because in saying it to you I am speaking to many others in this marvelous age of communication, that I very genuinely regret the impossibility of accepting all of them. Quite apart from the personal satisfaction and renewed assurance in direct contact with our people, I think that there is vast benefit in bringing the Government a little closer to the people, and the people a little closer to the Government and closer to those temporarily charged with official responsibility."

but actually millions of them. While a conservative estimate would put the number of the President's audience at a few hundred thousand, it seems quite possible that at least a million people heard him speak. If so many did not hear him, they could have done so had they desired.

In this experiment, only a few broadcasting stations transmitted the President's speech but as soon as the high-grade telephone network can be developed economically, such a

speech will be sent out on different wavelengths by enough powerful radio stations, strategically located, so that it will be possible actually, not figuratively, for the Chief Executive to address *all* of his countrymen.

#### Still Trouble from Interference?

**I**N OUR last issue we gave out the glad tidings that "interference had been done away with"—that the new schedule of frequencies which the Department of Commerce had allotted to the various broadcasting stations has remedied all the trouble which, for so long, had harassed the radio listener.

The opinion was based first, on our general knowledge of what should interfere and what should not, and next, and more important, on the basis of our observations. As we mentioned in last month's editorial, the better class of amateurs have been able to get rid of interference even when the stations were only ten meters apart, or only five (even this very small margin being a frequency separation of about fifteen kilocycles) but these listeners were not considered when we gave it out as welcome news that the wavelength separation for closely adjacent stations in the new assignment was about fifty meters. With a good regenerative receiver this is about five times the margin necessary for non-interfering signals, but of course a good many people do not have regenerative receivers, and many of them who do are not able to make them perform as they should. With this idea in mind we investigated the interference, with the new schedule, on a non-regenerative receiver, using a triode detector and two circuits for tuning. The antenna has tuning of its own, by means of a step coil and variable condenser, and coupled to the antenna circuit (by a vario-coupler) is the second tuned circuit to which the detector is connected. At a distance of about ten miles from three stations, rated at 405, 455, and 492 meters respectively, there is no interference! Using a loud speaker, and adjusting the set to give a signal from one of the stations loud enough to be audible throughout the house, by means of the audio-frequency amplifier, the signals from the other stations were so weak that the ear had to be held quite close to the loud speaker before they were even audible. That's what we called "no interference".

In talking with one of our well known radio inspectors, however, we found that many



people still report interference; in fact, some go so far as to say the old schedule was better—that only one station should be allowed to send at a time. Of course, this is nonsense, the new schedule is a real step in advance and the Department of Commerce is to be commended in having taken it. What, then, is the matter with these people reporting interference? In general, we can say their sets are certainly not operating as they should, or else the set is too crude to be considered as a real radio receiver. Those sets made of a few turns of wire on an oatmeal box, with a crystal and telephone shunted around the coil, are not considered in this argument. Interference undoubtedly does occur in many sets of this kind, but complaints from such sources should receive but little consideration from the radio inspector trying to satisfy the public. Radio to-day has advanced sufficiently to warrant a fairly selective receiver; if the set is non-regenerative, two tuned circuits should be used, with comparatively weak coupling, and if a regenerative set is used, those operating them must study their action sufficiently to get reasonable selectivity.

To be sure, there are a few listeners who will undoubtedly report interference, even after observing all precautions. A few members of the radio audience live within a stone's throw of one of the broadcasting stations. They are really "out of luck," because the signal from the neighboring station will be able to drown out the distant stations even if the two signals are a hundred meters apart. In such cases only expert adjustment of an especially selective set, and the use of absorbing circuits, can eliminate interference. Fortunately only a small percentage of the radiolisters are so situated.

#### Preparing for Long Distance

**D**ESPITE all arguments to the contrary, we are of the belief that a great deal of the enjoyment which is to be

had from a radio receiver is found in our ability to astound our friends by tuning in a program a thousand or more miles away for their particular benefit. This mild method of "showing off" is sure to find disciples among us mortals for some little time to come.

There is something fascinating about hearing a concert from a long way off, and the pleasure does not seem to wane with familiarity. Some of the old ship operators spend much of their spare time listening for distant broadcast stations, much as the proverbial letter carrier, on his day off, takes a little walk. Among the radio manufacturers, merchants, and writers whom it is our privilege to know, there are many who feel a holiday or a vacation incomplete unless they have a radio receiver with them in order to compare the reception at distant points with the results they obtain at home.

And now, when the days are still long and there is more time for us to devote to radio than is possible in winter, would it not be wise for us to give a thought to the long-distance receiver we will want for use when the weather makes the care of a good fire and radio a most attractive pair of indoor sports?

Now is the time to begin work on that power amplifier, or super-heterodyne, or reflex receiver for use at home or in connection with various jamborees to be held by the sons or daughters



AN INTERESTED GROUP AT LONG BEACH, L. I.

Frank M. Squire, Chief Engineer of the De Forest Company, (standing just behind the bulldog) is trying a new model receiver, developed by him, which works a loud speaker from the small circular loop shown just to the left of the horn



of Something-or-Other to be given in the fire house or the town school next winter. Dancing to music played by an orchestra a thousand miles away is now possible—if you have the proper receiver in good shape. Are you putting your radio house in order for the good times that are coming?

### “Deaf Ears Hear Again”

**T**HERE have recently appeared several reports to the effect that people who have been deaf all their lives have been able to hear by means of radio apparatus; and the achievement was heralded as one of radio's greatest triumphs. We pointed out that a mistake had surely been made—sound was sound, and after the sound waves had left the diaphragm of the telephone it was a matter of no consequence to the ear drum whether the vibration of the diaphragm was caused by a radio signal or by ordinary wire telephone currents.

It seems worth while to point out this fact again in view of the importance given by

reliable newspapers to such articles as the one before us—“Deaf ears hear again through the magic of radio.” As the article consists largely of an interview with a deaf person who *had* heard radio signals the article is apparently a confirmation of the idea conveyed by the headlines.

How then does radio help these deaf people? Simply in this way: in the development of radio it has been found necessary to have amplifiers, the same kind of amplifiers as have been used for the past ten years by the telephone engineers in all their long-distance lines; by means of these amplifiers, which the average person naturally thinks of as radio, extremely loud sounds can be produced, as witness the loud speakers frequently used in large lecture halls by the “public address” engineers of the telephone companies. Now evidently amplifier systems are exactly what the average deaf person needs. Probably many “deaf” people are not absolutely deaf—loud enough signals might well be audible to them no matter how hard of hearing they might be. This is what radio

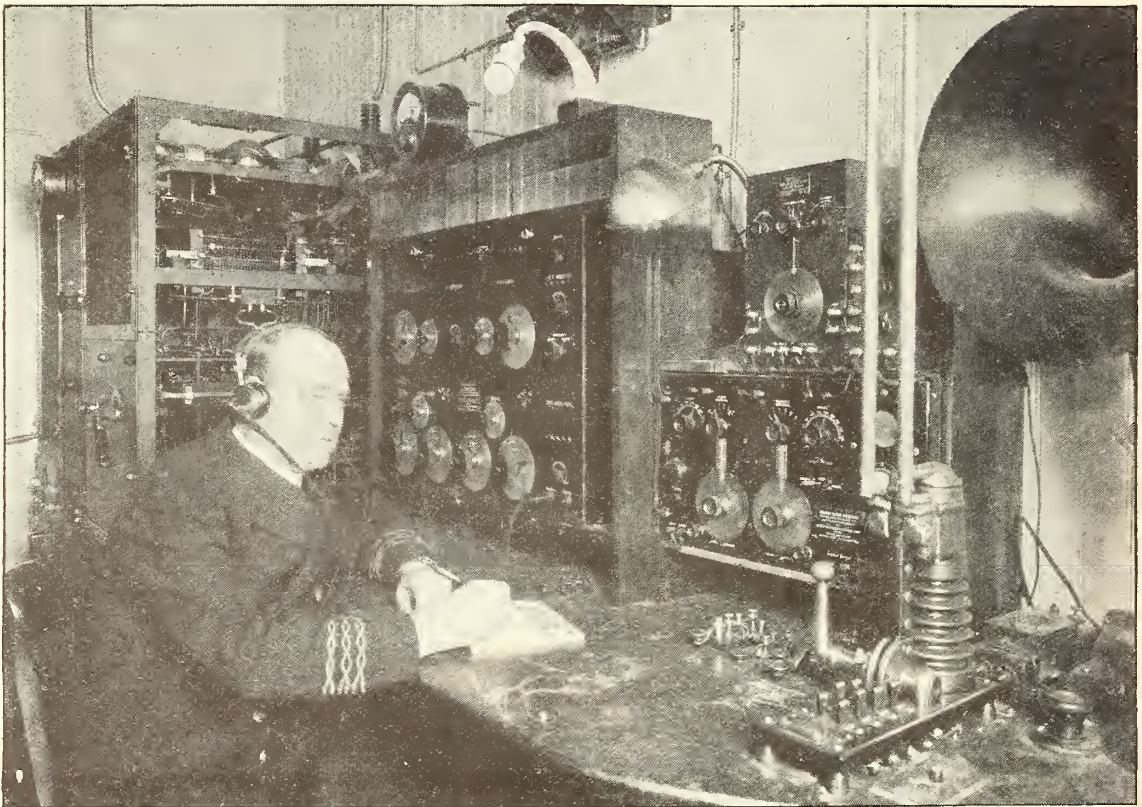

CHIEF RADIO OFFICER E. N. PICKERILL IN THE OPERATING ROOM OF THE “LEVIATHAN”  
Uninterrupted service with points 3,000 miles away is claimed for this ship's radio apparatus





© Underwood &amp; Underwood

THE "LEVIATHAN"—SHE CARRIES THE MOST POWERFUL RADIO EQUIPMENT OF ANY SHIP  
 The "duplex" system of radio telephony, whereby conversations may be carried on as over a land line—without changing from "send" to "receive"—has been installed on this floating hotel by the Radio Corporation

is doing for the deaf; enabling them to apply to their ear drums signals perhaps ten thousand times as loud as the ordinary person requires for normal hearing. Such amplifying systems are entirely apart from radio in the strict sense of the term, however. The same apparatus attached to the ordinary telephone line would permit the deaf to hear ordinary telephone conversation perfectly well, and yet this would evidently not be an achievement of radio.

We must remember, however, that radio makes available to the deaf, concerts, programs, and speeches, in such form that the amplifying apparatus is able to strengthen it sufficiently for their hearing. Thus even though the radio waves, as such, do nothing to make the deaf hear, the apparatus associated with radio has no doubt proved a great boon to them. If one is very deaf, a good deal of amplification is necessary; one person known to us has a five-tube amplifier, and wears head phones! As he says, "it costs money if you're very deaf." So delighted was he actually to hear that he burned up two of his tubes the first hour, trying to increase this amplification.

A real advantage of this use of the amplifier is that by using the head phones, the deaf person can have his signals as loud as he wants them; yet people around him are not disturbed,

or even aware of the extremely loud signal to which he is listening.

It is possible, too, that the continued use of greatly amplified signals beating upon the ear drums will cause the organs associated with hearing to improve, due to exercise. We know, for instance, that a broken arm or leg, after being held in a plaster cast for a long period is difficult or impossible to use immediately after the cast has been removed. But when the newly knitted member is exercised periodically, the muscles gradually become stronger and we find that the member may be used quite as well as it could before the period of inaction began. Some interesting experiments are being carried on, taking advantage of this method for improving hearing, and some favorable reports of the results obtained have reached us. It is a very worth-while undertaking and should be encouraged.

#### Marconi Making Progress With His Short Waves

**A**BOUT a year ago Senator Marconi reported before a joint meeting of radio and electrical engineering societies, at a meeting in New York City, his interesting and apparently promising experi-



A COIN-BOX BROADCAST RECEIVER IN PARIS

In some of the Parisian cafes, movie houses, hotels, and other public places are now found "Radio-Automatic" stations at which any one may listen-in on broadcasting programs for a few centimes, at times indicated on a chart hung near the instrument

ments in short-wave radio. He showed experimentally how the short waves could be reflected by an "electrical mirror" and sent in any desired direction, like light waves, and how easily they might be absorbed. There was nothing new in these special experiments, Hertz having done exactly similar ones in his laboratory thirty-odd years previously, but the experiments did indicate to the large and enthusiastic audience how Hertz's laboratory experiments on short waves might be turned to practical use. It was evident to every one that if radio waves could be confined to one direction, instead of spreading out in all directions, much less power would be required and much interference would surely be eliminated.

From a recent interview given by Marconi to the London press it appears that he has been applying himself to the problem with very successful results. Although he did not mention short waves as the means he employed, reading between the lines of his interview, we are forced to conclude that such was the case. "We have transmitted messages up to a distance of 2,500 miles, not only with much smaller power, but also far more cheaply than with the ordinary system of long-distance

wireless," he said. "To send the message 2,500 miles took less power than the ordinary message from London to Paris. . . ."

Our best wishes are extended to the radio pioneer in this new field he is developing. We should ourselves be doing more, in this country, to open up this unexplored, but very promising, field of radio transmission.

### Radio an Auto Accessory in Jolly Old England

EVERY potential buyer of a modern motor car knows that long list of "accessories." They bristle all over the specification; they crop up in the selling price; but in the car itself they are models of unobtrusiveness. Some of them are absolute necessities: a good many of them are not. Attractive accessories, contrived to add just a degree more of comfort and convenience for the user, are constantly being devised by makers who see in them an additional something to sell.

It was therefore to be expected that with the recent rapid development of wireless broadcasting and the perfection of portable "listening-in" sets, motor car manufacturers would soon be considering the adaptability of yet another luxurious accessory. The Daimler Company was quick to realize the possibilities of carrying a portable wireless set on its cars, and the Marconi Company, doubtless with business prospects also in mind, has combined with it to overcome some of the technical problems involved.

In October of last year two Daimler landaulettes made a reasonably successful experimental run from London to Chelmsford and back, fitted with an installation which appears crude in comparison to recent achievements. Their biggest problem was, of course, the antenna. As everyone who is interested in wireless is aware, the height of the antenna which picks up the transmitting station's signals has a great bearing upon the ability of the vacuum tube to produce clear sounds in the receiver. A traveling motor car is, obviously, no place for an antenna of more than insignificant height, so that the first experiments were made with an ingenious contrivance, shaped rather like a catherine-wheel, and mounted pivotally to the roof of the car. This was actuated by a small hand wheel which rotated the antenna through a certain number of degrees, and so



was able to obtain the best results from signals coming from all points of the compass. By this means a directional value was given to it, which compensated for loss of height. When not in use it could by means of the same hand wheel be folded down to lie flat upon the roof of the car.

In any case, the antenna was unsightly and very much in the way, so the experimenters quickly evolved a flat antenna consisting of a copper plate, suspended and insulated from the luggage rail on the car top at eight points. This, it was found, overcame all the receiving difficulties and proved actually more efficient than the frame antenna. Later it was found possible to build it into the car between the coachwork of the roof and the upholstery. From the centre of the lower side of the copper plate, lead-in wires passed down to the receiving set within the car.

In the earlier models, the tuning apparatus was in the form of a vertical projection, rather awkwardly placed, and having three

controls. This has been replaced by an eight-tube receiving set (five radio-frequency, a detector, and two A. F. amplifiers), neatly and compactly enclosed in a small upholstered box to the left of the back seat. Four people can listen-in on this set at the same time, using either one of the light single earpiece receivers provided, or, if they prefer it, the ordinary double head-phones.

Another problem was the disturbing influence set up by the ignition apparatus of the car itself. Each spark-plug was found to be a miniature transmitter, throwing off waves which could plainly be heard in the receivers. This has been overcome by enclosing the magneto in a copper box, and each spark plug in a copper sheath. Moreover, each high tension wire is run through a flexible copper casing, the copper in every case serving to ground the disturbing waves and minimize their effect.

As a motor car is insulated from the roadway by its tires, the next problem was to devise an

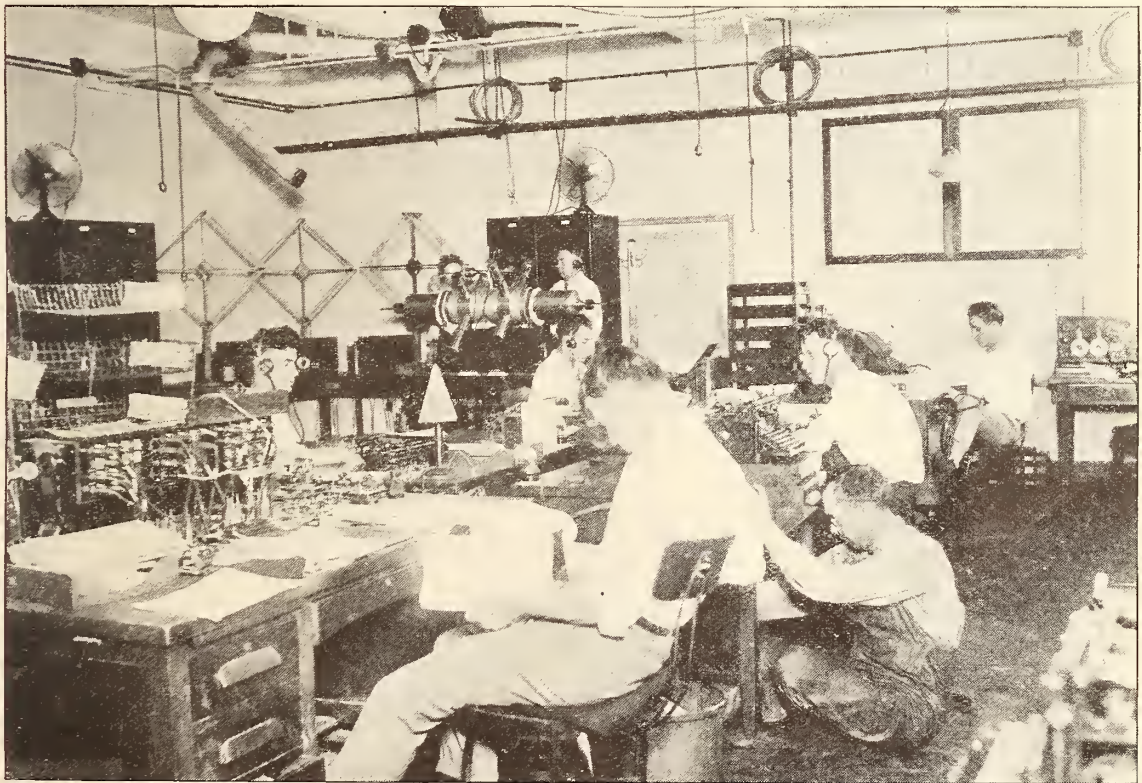

© Harris & Ewing

HERE MESSAGES ARE SENT AND RECEIVED THROUGHOUT THE WORLD

The Radio Central room of the U. S. Navy Department. Communications are transmitted to Lyons, London, Balboa, and to fleets operating near Constantinople. This station has picked up a message from Cairo, Egypt. The "clarophone," or static eliminator, invented by W. J. Scott of the Navy Department, is seen in the background (small cylinders projecting from a large horizontal cylinder)



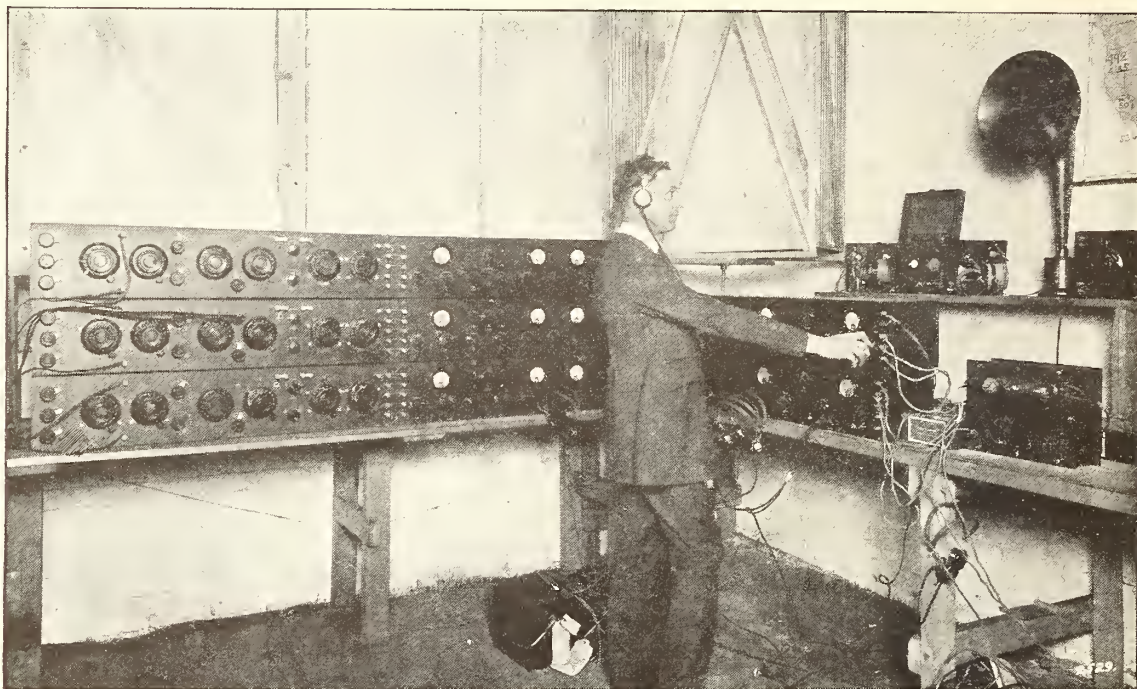

RECEIVING FIVE CONCERTS AT ONCE WITH SUPER-HETERODYNES

Claude Golden in the Research Laboratory of the Experimenters' Information Service, New York, tuning in on Pittsburgh, Chicago, Schenectady, New York, and Cleveland

efficient "ground." They soon found that the frame of the car made what is called a "capacity ground," which, although not so efficient as a true "ground," served the purpose very well indeed.

The A and B batteries and valve panel are neatly and cleverly put away out of sight between the floor-board and the chauffeur's seat. No technical knowledge whatever is required to operate the tuning controls contained in the small upholstered box to the left of the back seat: only the simplest operations are necessary to achieve excellent results.

So efficient has this apparatus proved that the Daimler Company proposes to build plate antenna into the roofs of all their cars as standard fittings, so that the purchaser who wants to install a wireless will have his antenna ready at hand.

The Daimler Hire Ltd., of London, has already installed sets in fifteen of its fleet of 250 cars, and so great has the demand been for them, that the company is busily engaged in fitting more. "2LO," the London station of the British Broadcasting Company has been heard clearly and distinctly from Southampton on one of these cars, while only the other day

a car on the road in the neighborhood of Uxbridge picked up signals from a station at Newcastle.

As an "attractive accessory," the wireless set has undoubtedly come to stay: how soon the portable transmission set follows it remains to be seen. At the present rate of development, what is now but an ingenious pastime may soon pass into the sphere of commercial usefulness.

"Frate Sole" Is Carried Across Continent to Composer's First Instructor

PROBABLY not more than a dozen persons were cognizant of the drama of the air that, according to the San Francisco *Chronicle*, was enacted recently, when Giuseppe Bartalo, aged teacher of Luigi Mancinelli, author of the motion picture opera "Frate Sole," which was presented at the Civic Auditorium in San Francisco, heard in New Orleans his pupil's last composition, broadcast from station KPO in San Francisco.

It was Bartalo who, many years ago, shaped the musical foundation of Luigi Mancinelli in far-off Milan, when the little boy with the



serious eyes came to him for his initial instruction. Proudly he watched the fruits of his labors, as Mancinelli developed into a composer whose operatic and symphonic scores were familiar to thousands.

While Mancinelli was climbing to fame, Bartalo was establishing himself in America. The roads of pupil and teacher parted. Mancinelli rose high in his profession, but he never forgot the instructor to whom he owed his early training and encouragement. Frequently he wrote him, and sent him copies of his newest scores. And Bartalo's breast would swell with pride, and he would tell his friends tales of his Luigi as he always remembered him.

In 1922, Mancinelli died. Bartalo was heart broken. He collected all of his pupil's works that he could find. But some of the latest works he overlooked, among them, "Frate Sole," which he had never heard. No more had America. When arrangements were made to bring "Frate Sole" to this country, no one thought of little Bartalo, down in New Orleans.

When a special concert was arranged through station KPO, so that the radio world might hear a fragment of the dead composer's work, friends recalled the aged maestro. Telegrams were exchanged between San Francisco and New Orleans. As a result of them, little, old, bent Giuseppe Bartalo sat at a receiving set half across the continent, and with tears streaming down his cheeks, as he later explained by telegram to KPO and to his friends, heard again the living fire of "Little Luigi."

### Private Radiophone Communication

A RECENT announcement from the Bell System's engineers states that the famous radio link in their telephone network, connecting Los Angeles with Catalina Island, is soon to be abolished, as the radio service is not as economical as the cable service between these points. Having found the Key West-Havana cable service satisfactory, the telephone company has decided to put a cable to Catalina. But before dismantling the radio plant the engineers have been experimenting with a scheme for private radio telephone transmission—a scheme such that any one not "in the know" could not decipher it. The experiments are said to have been successful to the extent that the average receiving set could hear nothing intelligible from the station. It seems, however, that one skilled in the art

could soon adjust his set to pick it up. The system, we judge from the interview the engineers gave, is not similar to Marconi's directive radiation scheme but probably one which broadcasts the radio signal without the carrier wave; as this is necessary to make an intelligible signal it must be put back into the signal at the receiving station and if one did not appreciate this fact, the speech would indeed be "private." If our guess is correct, this scheme is far from being private because it would not take long for the average listener to learn what to do to his set to put the requisite carrier wave back in to the received signal.

### Service is Necessary

IN YOUR own sphere of acquaintances how many people have you known, who, after procuring a radio receiver, could secure anything like satisfactory results before you or some other person versed in operation showed them how to adjust the knobs properly? Again, how many of these same acquaintances could make head or tail out of the instruction book they received with their outfit—if, indeed, they received one?

Inquiries of this nature among our own acquaintances have brought home the need for reliable service with every radio receiver put in the home. We believe that the reliable radio dealer a year or two from to-day will find that the sale of one or two standard lines of complete receivers will pay him well enough to allow a fair profit above his expenditures and permit him to give the desired service at a comparatively low figure. As in the automobile business, it will be possible for him to make a definite charge for service after the guarantee period has passed. And it is more than likely that the cost of supplying service on newly installed machines may be kept down to a minimum by sending a representative, capable of instructing the purchaser, to check up each installation and show its owner how to secure the best results from it.

Along with the idea of service comes the thought that much of the high-class radio business of the future will be done on the time payment plan, and the merchant who can secure proper financing and is willing to convert service from a liability to an asset by advertising it properly has his finger on the latch that will open the door to prosperity for him.

J. H. M.



CHRISTMAS DAY AT THE HOME OF 6KW  
Office building at the Tuinucu Sugar Company plantation

## Set-Backs and Come-Backs at 6KW

A Story of the Building and Operating of the Well-Known Amateur Broadcasting Station in Tuinucu, Cuba

By FRANK H. JONES

**I**N 1920, when the Westinghouse Company first started broadcasting from KDKA and WJZ for local listeners, I surprised them as well as myself by picking them up clearly here at Tuinucu, Cuba—a distance of 1,250 miles—with a single-tube regenerative circuit. Later, I added audio-frequency amplifiers and we were dancing to music transmitted by these stations before they could believe they were reaching out more than a few hundred miles at best. But the joke was really on me, for I thought they must be using at least five or maybe ten kilowatts, and you can imagine my surprise when I found that they were not using more than  $\frac{1}{2}$  kw. We heard them so well at times that for all the 1,250 miles from KDKA and 1,375 miles from WJZ, the

thought took root in my mind that maybe I could reach out half that far with a set, say, of 100 watts, carefully constructed and accurately adjusted.

In December, 1921, I decided to make the plunge and thought that all I had to do was order what I wanted, set it up, and proceed to startle the world. I ordered all the necessary apparatus to make a 100-watt set, using Kenotron-rectified current on the plates—that is, two 50-watt oscillator tubes and two 50-watt Kenotron rectifier tubes, planning to use magnetic modulation, this being considered simple and easy to operate.

This was about the time when broadcasting started to boom, and I then had my first of a series of disappointments. It was almost



exactly a year before I was able to get together, down here in Cuba, all the necessary parts for that first transmitter. First a few sockets came, and some transformers; then a long wait and some condensers and Kenotrons; then another long wait and some more condensers and the Radiotrons. Then I would find that one tube had arrived with a broken grid and another with a broken filament. It's a long way down here and the boxes receive lots of rough handling. It seemed as though the fates were against me, but finally the great day arrived when I had all the stuff I needed *at the same time!*

Of course I had already put up an antenna, having planned to transmit on about 300 meters. I used an inverted L 200 feet long with a series condenser to get down to 300 meters. I did not have a thermal galvanometer wavemeter, but just a buzzer device which I had used to calibrate my receivers, and I had expected to be able to employ this by using my calibrated tube receiver as a wavemeter with phones. It was truly an exciting moment when I first turned on the current with fond expectations of having to buy a new antenna ammeter so the reading wouldn't go off the scale (I had a meter reading 0.5 amperes.)

I was glad I had no expectant audience, for the meter needle never budged a hair's breadth.

Then followed industrious retracing out of circuits and rechecking approximate calculations I had made on the various values of capacitance and inductance to give me the 300-meter wave. The circuits all checked up O. K. From then on I sweat blood. I'll bet, if I tried one combination of capacitance and inductance in the various high-frequency parts of the circuit, I tried 999,999. Remember, I had no laboratory testing meters and apparatus and so had to try various combinations—and try them carefully—so as not to burn up any apparatus. Well, to cut this part of the story shorter, I'll say that I finally made a very slight change in the inductance value of one of the coils, and lo and behold, I had a radiation of about two measly tenths of an ampere! Eureka, I was getting along.

But what was the wavelength?

I could hear the ding thing *all over* my receiving tuner.

"*Que pasa?*" as we say in Spanish.

Had the manufacturer forgot to send the wavelength, or had there, somehow or other, sneaked in too many?

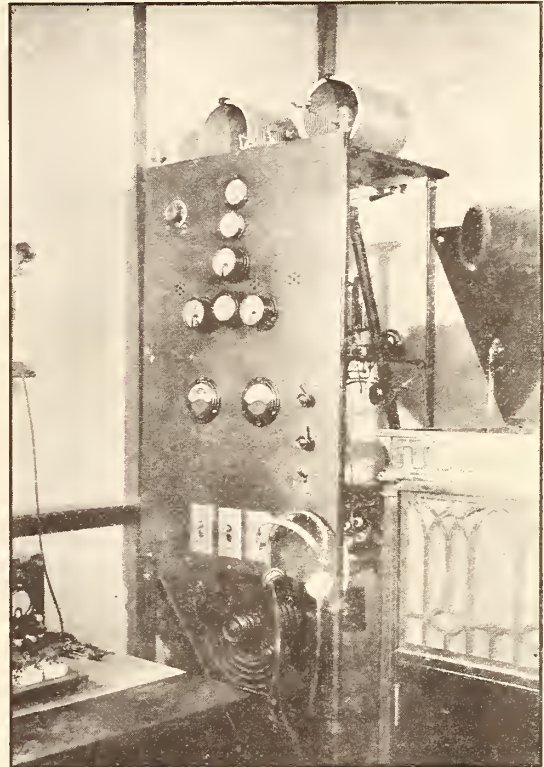

THE TRANSMITTER PANEL AT TUINUCU

Well, finally, after deep, heavy, thinking, I decided my radiation (?) was principally on a wave somewhere around 228 meters. I asked a friend living about 1,000 feet away, if he could hear me, and he said yes, so then after calibrating his receiver, I asked him to let me know what wave I was radiating. He said he didn't think it was a wave at all, but sounded more like a buzz-saw.

Some people always try to be funny when you're serious.

I finally wrote to my good friend Pierri of R. C. A. and upon his advice got a thermal galvanometer wavemeter. Oh boy, that's the finest piece of testing apparatus I ever had my hands on—quick and easy to operate—but they sure dent your pocket-book. With it I began to get somewhere. I found I was really radiating fairly sharply on 250 meters. It's some satisfaction to know where you're at, even if you don't know how you got there nor where you go from there.

After making 'steen thousand more trials and combinations (incidentally burning out only two 50-watters), I finally boosted my current in the antenna to  $1\frac{1}{2}$  amperes.

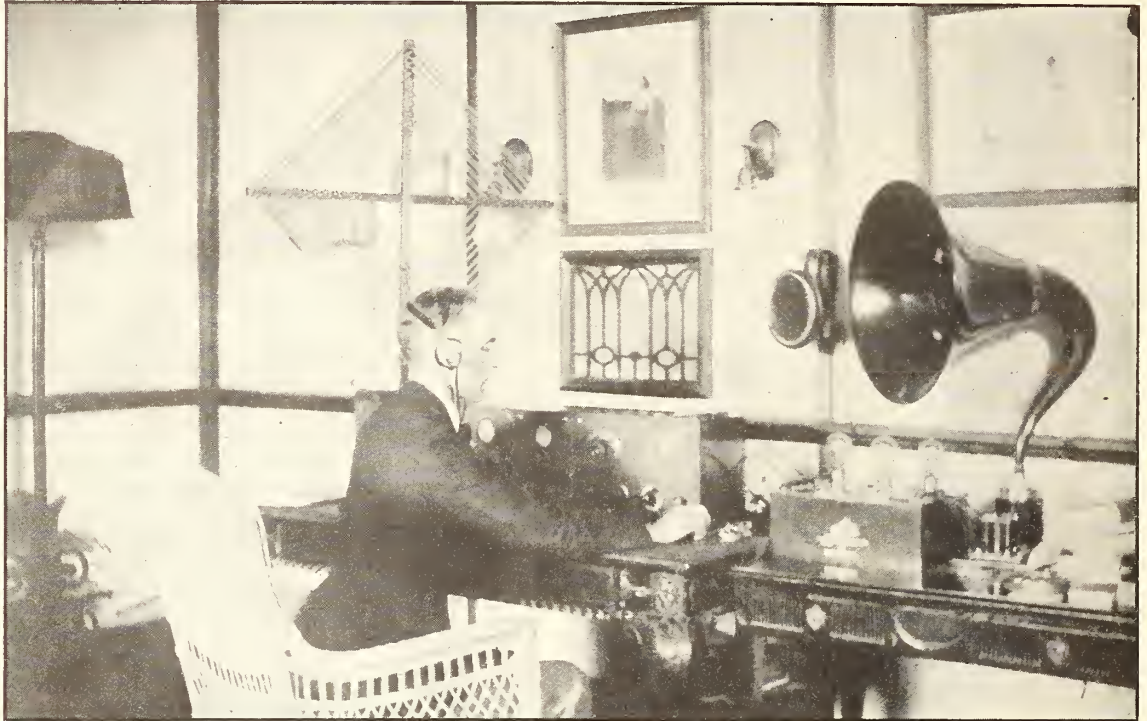

MR. JONES AT HIS RECEIVING STATION

From here the telegraph transmitter, located in another room, is operated by remote control. I.C.W. (interrupted continuous wave) transmission is carried on under the call letters 6XJ, on 275 meters

*Viva Cuba, viva yo, viva everybody!*

I then seemed to be stumped. But I came across an article in a magazine that said an earth was the poorest kind of a ground, or something like that. My pocket-book was already getting flat and I couldn't think of importing any special dirt from U. S. dealers who "guarantee" everything to add 100 per cent. efficiency to everything. We had lots of dirt here, and I had always thought it was pretty dirty dirt; but apparently as a ground it didn't speak the right language for radio.

Curtain after great gloom.

Scene Two: Same as before.

Enters the hero, "Jack Counterpoise."

Well, to come down to earth (grounds) again—I read many lines on how *not* to construct a counterpoise and then discovered I would have to cut down all the nice trees around our bungalow, and move the house away and level off the ground.

I consulted my wife.

Result: house stays where it is and trees also. Then I wished that my little son Vincente would turn out to be a second G. W. Without giving him any hints, for one has to be honor-

able with one's wife, I gave him a nice nickle-plated hatchet for his birthday and told him he mustn't cut the trees. (Tough luck, he obeyed.)

My wife said she had read lots of things in books that she knew were not true, so maybe the ones who wrote about counterpoises didn't know everything, either. She said, "Why don't you put up your old counterpoise contraption *over* the trees and *over* the house."

So I did.

I don't know by experience what a theoretically good counterpoise could do to my set, but anyway, the one I put up over trees 'n everything, boosted my antenna current right off the bat to  $3\frac{1}{2}$  amperes on straight C. W., on 275 meters; and then to around  $4\frac{1}{2}$  on 342 meters after I had made a few thousand more adjustments.

Now I connected in the magnetic modulator which brought the current down to around 3 amperes after re-tuning. The phonograph was then started and my friend about 1,000 feet away was asked how it sounded. He said it didn't sound at all, it buzzed. I asked him if it buzzed like a saw-mill and he said no . . . it buzzed like about ten saw-mills.



I then wrote down in my log, "Communication just received from one thousand feet away saying we are coming in loud—"Can hear you all over the house.""

I was surely "radiating" now.

"Can you hear the music?" I asked him.

"Yes, maybe," he came back, "if you could shut down the saw mills."

Some people are so unappreciative.

Well, naturally, I decided the filter circuit must be leaking, so I added more condensers and filter coils, took some out here and put them there and after trying many combinations I finally found I could eliminate most of the 60-cycle hum by proper adjustment of the filament-tap return on the tank inductance. I was then using circuit No. 5 of the R. C. A. catalogue.

My first report was from a sugar mill about 80 miles from Tuinucu, using 342 meters. My friend, Mr. Leonard Fox, the manager there, and a fellow radio fan, said he heard me fairly loud with quite a bit of hum.

With this arrangement I experimented and transmitted for about two months, finally greatly improving the modulation by bridging a variable condenser around the secondary of the magnetic modulator with a value of

about .003 mfd. This, also, cut out a lot of the remaining 60-cycle hum. I was then being heard all over Cuba, with maximum distances in Cuba from Tuinucu being around 300 miles.

Friend Pierri of the R. C. A. then suggested that I try the same set using one 50-watt tube as oscillator and one 50-watt tube as modulator, adding the necessary choke coils and making a slight change in the wiring circuit. This gave me  $2\frac{1}{2}$  to 3 amperes in the antenna on 310 meters, and letters began to come in from points in Florida, U. S. A. saying they were hearing me quite clearly. After that, I added a 5-watt tube as speech amplifier in front of the modulator tube and all during December of 1922 and January, February, and to March 1, 1923, my 50-watter, so arranged, was heard quite consistently all through the Southeastern states with a goodly number of reports from Pennsylvania, New Jersey, New York, and Porto Rico.

While I was still fussing around trying to get rid of my 60-cycle hum, an enthusiastic (?) listener wrote me in Spanish asking if I would kindly do my transmitting during the "madrugada" (midnight to morning) as he wanted to listen to KDKA and my battery of saw mills "distracted" his attention.

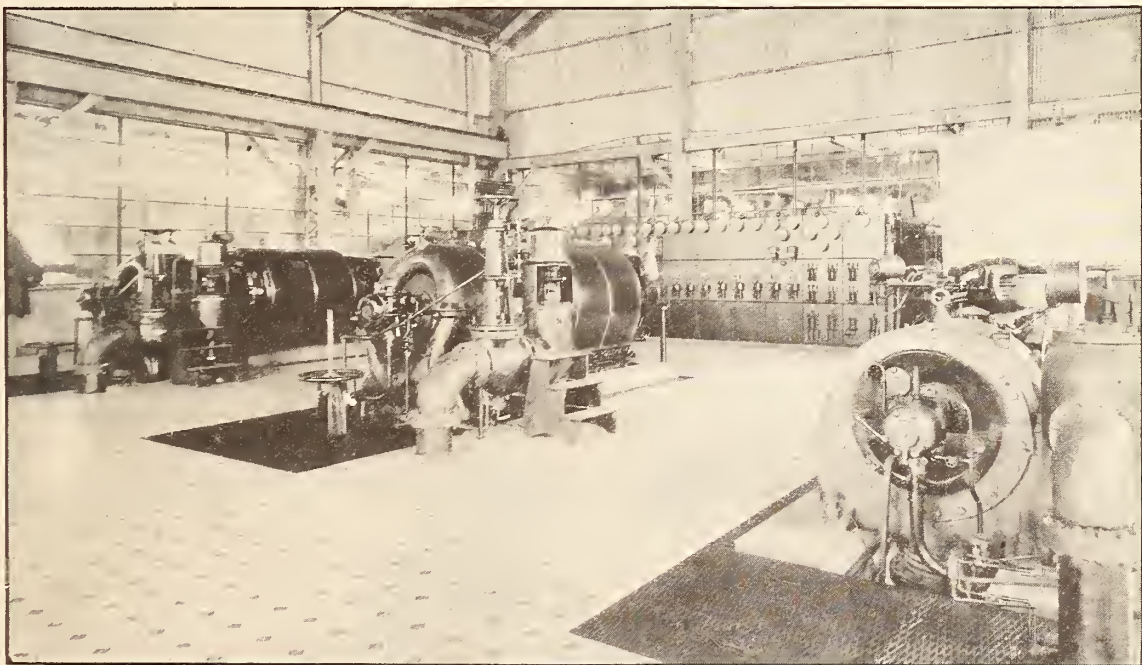

THIS IS WHERE THE "JUICE" ORIGINATES FOR 6KW

As the power plant of an amateur's broadcasting station, this would indeed be imposing, but it is first and foremost the power plant of the Tuinucu Sugar Company, of which Mr. Jones is chief electrical engineer

These Spanish people are *very* polite.

*Caramba, pensé yo, mi idea original era tener un trasmisora de 100 vatios. Voy!!*

So I squeezed my pocket-book again and bought some more tubes, coils, condensers—and a 1000-volt D. C. generator. No more 60-cycle hum for me, and with D. C. you don't have any hum to filter out, oh, of *course* not! More waiting.

I swear to goodness, from the time it takes to get this kind of apparatus down here, one would think that every one of a million people in the U. S. A. were building transmitters also.

Considerable difficulty was encountered at first in eliminating the hum caused by the commutator ripple of the D. C. generator, but this was finally almost perfectly accomplished by using about 9 mfd's across the D. C. and some additional filter coils as shown in the circuit (page 374).

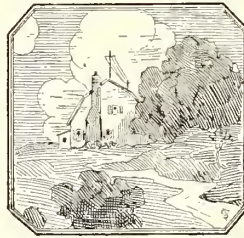

The antenna current on 315 meters with 900 volts on the plates is  $3\frac{1}{2}$  amperes, and this increases to  $4\frac{1}{2}$  during speech or music. I now transmit concerts on 315 meters and my broadcasting license, under Cuban laws, allows me to use from 300 to 360. The call letters of this license are 6KW. It is a Cuban class "C" station.

I am also a member of the American Radio Relay League and this summer I hope to open up traffic between Porto Rico and Cuba and amateurs in the U. S. A. I have also a class "B" license which down here is for amateur phone and C. W. telegraph. No spark transmitters are to be allowed in Cuba. Move along, you rock-crusher operators in the States and don't let Cuba lead too long. Don't try to sell it to some newcomer, just bury it and stand the loss and your new C. W. set will more than pay you. I know—I used to have a spark set way back in 1907. My class "B" license call number is 6XJ, and I shall use I. C. W. on 275 meters. Next winter I shall use straight C. W. for work with England and France.

Ye Gods, when I think back. . . . With my old spark set of 1 K. W. rating, I used to get 50 to 75 miles when she was "good" and I take off my hat to the boys who get such fine DX work on only 20 watts.

I first tested out my new 100-watt set on March 9, 1923, and had previously advised a

friend, Mr. Donald Hutchinson of North Tarrytown, N. Y. to be listening for me. He cabled next morning that he heard me so loud and clear that he couldn't comfortably use the headphones.

The modulation of Station 6KW has been reported good from Dakota to St. Johns, Newfoundland, signals clear, wave steady, and good volume. Literally, thousands of letters have been received from enthusiastic listeners, and I do think that for 100 watts it gets out very well.

I have many letters from Canada. Hundreds up there have reported 6KW louder and clearer than some of their good-sized local stations. I don't pretend to explain this. Perhaps someone will come along and explain away the mystery. 6KW has been heard many times with consistent volume and clearness in every state east of the Rocky Mountains; in Canada, in every province from Saskatchewan to Newfoundland.

St. John's is 2,500 miles from Tuinucu. Reports have come from all over Cuba, of course, Porto Rico, Hayti, Jamaica, Mexico, Central America, and throughout the Panama Canal Zone. I don't believe they have any receiving sets in the northern part of South America, for from there to Tuinucu it is only 900 miles, and I have no report as yet from South America.

The koo'ing of a cuckoo bird is reproduced between numbers during concerts and the slogan which I adopted is "If you hear the 'koo' of the cuckoo, you are in tune with Tuinucu, Cuba."

A perusal of the letters received by a broadcasting station reveals some curious phases of psychology. On one night when I transmitted nothing but phonograph records, I only announced "phonograph record" after one particular selection. A man wrote in saying that he liked all the orchestra selections, but that he did not like "the phonograph record" and never did like phonograph records over the radio. My experience is that eight out of ten people can't tell the difference, if the transmitter is working well, the record is new, and the microphone properly placed.

Another man wrote in from the frozen north asking if I operated the transmitter in pajamas! No one suffers with the heat in Cuba. Sunstroke is practically unknown. One is usually comfortable at night with a light blanket on the bed.





THE STUDIO IN MR. JONES'S HOME

Many listeners-in pleaded to have me open a bottle of champagne in front of the microphone and let them just hear the "pop."

We have winds here in Cuba that play havoc at times. You may look at your antenna in the morning and think what a beauty it is; and the next night it's on the ground, maybe, masts and all. Then we just heave to, and put it up again and "nothing to do till to-morrow."

And lightning during the summer months, WOW! Several times I have seen all the incandescent street lamps light up with a heavily charged atmosphere here during storms. You can open your antenna grounding switch  $\frac{1}{4}$  inch many times with a clear sky and a continuous stream of  $\frac{1}{4}$ -inch sparks will flow from antenna to ground. Once my antenna was found all tangled up in a tree a quarter of a mile from its home.

The Cuban government first assigned me 5KW and after I had been announcing this for about a week they changed it to 6KW. The numbers refer to the Provinces. No. 1—Pinar del Rio; Nos. 2, 3, and 4, Havana; No. 5, Matanzas; No. 6, Santa Clara; No. 7, Camaguey; and No. 8, Oriente.

I transmitted for several months before I had call letters, but I had a special permit, so, while I was OK legally, it caused many dis-

cussions in the States as to why the station of "Frank H. Jones" never signed off with call letters.

Naturally musical talent is hard to obtain here in the "woods" as one might say, but we very frequently have orchestras here from nearby towns for dances in the "*Sociedad*", "*Escuela*", or the manager's house on the plantation. I have put up private metallic circuits to all these places running to my house and also from our "park" and all the concerts and dances and "doings" in these places I can transmit.

The Cuban Government also authorized 6KW to broadcast officially the weather report which is telegraphed to me daily from the National Observatory. I pick up also in the early evening, many bits of news by radio from the States and sometimes I broadcast these.

Tuinucu (pronounced Too-e-nu-koo) has been spelled no fewer than hundreds of different ways, some listeners even addressing their cards "Stoni-cove," "Cuni-kuk," "Cookuticuk," "Punicu," "Sonnicu" and "Boomicu." My wife gets the most fun reading these addresses. Tuinucu is the plantation town and home of the Tuinucu Sugar Company cane-sugar mill. It is located almost exactly in the centre of the island of Cuba about eight miles

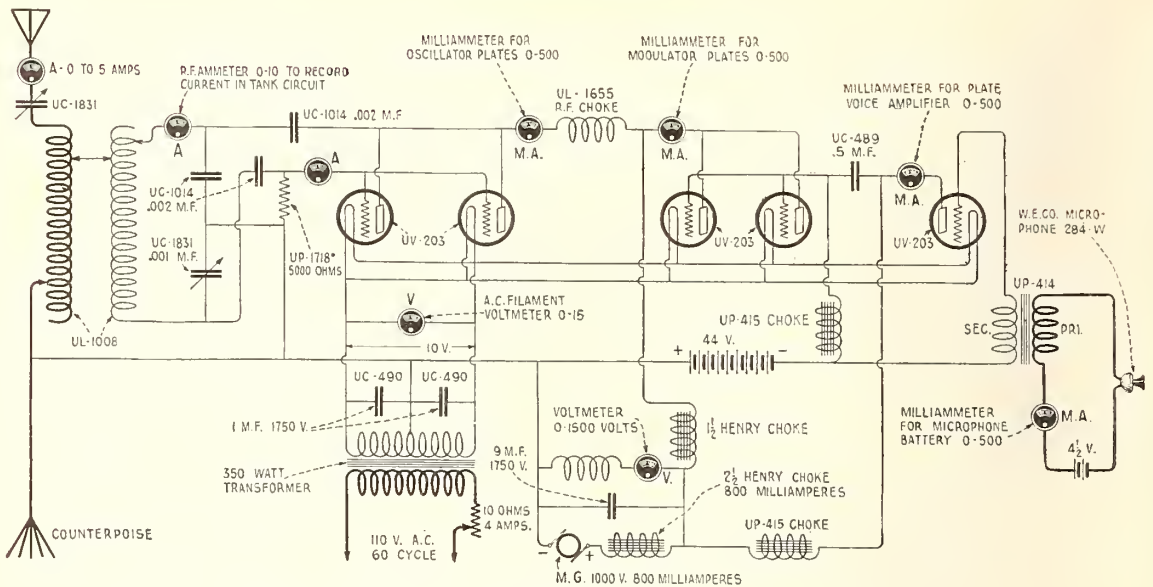

DIAGRAM OF THE TRANSMITTER CIRCUIT USED AT 6KW

northeast of Sancti Spiritus and about a mile west of Zaza del Medio, both of these latter towns usually being found on maps, although Tuinucu may not be shown. Tuinucu is 200 miles by air line east of Havana.

Some operating data on the transmitter when using the 315-meter wave may be of interest. The current in the tank circuit may be around 8 amperes when  $4\frac{1}{2}$  is being radiated. Under these conditions, the oscillator tubes show about 280 to 350 milliamperes in the plate circuit; the modulator tubes 100 to 400 milliamperes on plates, and amplifier tube plate from 25 to 125 milliamperes; these currents applying when the plate voltage is 900 volts.

In eliminating a transmitter in a receiver, one has to be as careful in the wiring as in a good receiver. All the leads liable to produce feed-back effects are run in lead-covered wire with the casings grounded. I first had the  $1\frac{1}{2}$ -henry choke near the modulating and oscillating tubes, but its strong flux made it necessary to place it farther away. I found that it is also well to mount the tubes on several thicknesses of felt. All mechanical vibrations have to be carefully guarded against. I first had my motor generator in the same room as the transmitter, but even its slight vibration was picked up by the amplifier tube and tremendously amplified. I then mounted the motor generator in another room about 30 feet from the operating room and on a concrete base extending from the ground up through the floor of the house but *not touching* the floor.

Just a word about my receiving apparatus. I have built and tried out almost every circuit I ever saw described, but for good, reliable work, both near and DX, I use either my G. E. Company single-circuit or my Westinghouse R.C. Either of these is generally sufficiently selective with a fairly short antenna and plenty of tickler coupling and low filament voltage.

I began playing the game of "Radio Golf" a couple of years ago, and after I had made a score of more than 100,000 miles I quit keeping track. My real object in starting the game was to get people really to know how to use their detectors. My watchword was always: "What I can't hear on detector alone can't be heard on audio amplification."

I built a radio-frequency with 3 stages of R. F. and detector (page 370), this set being arranged with various combinations to use antenna or 18" loop alone or in combination with the well-known three-circuit regenerative tuner, using vario-coupler, grid variometer and plate variometer. On the loop, I have heard everything I have been able to pick up on the antenna with the detector alone in the regenerative set. Generally speaking, however, I prefer to use my single-circuit sets. With them I can usually pick up a station and tune it in (if it's possible) in a few seconds, while to pick up and tune in well a station 1,000 miles away on the R. F. set, requires a lot of time and more patience. Of course, in the case of a real, "dyed in the wool" radio amateur, his middle name is patience.



# The Thoriated Tungsten Filament

Characteristics of the New X-L Filament, Used in the UV-201-A and UV-199 Tubes. Comparisons with the Older Pure Tungsten Type



By W. C. WHITE

General Electric Company

The papers of the Radio Club of America are being published exclusively in RADIO BROADCAST. Mr. White's discussion in this number is the second of the Club's articles to appear. The first, "Eighteen Years of Amateur Radio," by George E. Burghard, was published last month.—THE EDITOR.

**I**N THE design, manufacture, and use of high-vacuum receiving tubes, the electron source, in most cases, has always been the chief problem.

By far the greatest amount of scientific work on vacuum tubes and also a considerable part of the manufacturing development has been devoted to this question of the production of electrons.

Until quite recently, the pure tungsten filament and the coated filament were the only two types of electron-emitting sources in extended use in receiving tubes. Although each of these sources met the requirements of practical use, it has been found possible to reduce the filament energy and secure other characteristics equal or better than that formerly obtained.

The important desirable features which the ideal electron-emitting filament for a high-vacuum receiving tube should have, some of which are self-evident, can be listed as follows:

- (1) Long operating life.
- (2) Low filament energy to supply the necessary electron emission.
- (3) Uniformity of electron emission during life.
- (4) Uniformity of electron emission among different tubes of the same type.
- (5) Quietness of operation.
- (6) "Electrical robustness" of the filament.

Another most desirable feature, if not the most important, but which is not so self-evident, is the necessity for low electron emission per unit of length or, expressed in another way, the greatest length possible within reason for a given amount of electron emission and filament energy. These features of long filament length combined with long life and low filament energy were always the difficult problems in tungsten filament design for receiving tubes.

The new X-L tungsten filament meets these

many, and it would almost seem, divergent requirements in a most admirable way, and although, of course, it is probably not the final development in electron-emitting sources, still it is such a big advance, particularly over the old type of pure tungsten filament, that it meets to a considerable extent the ideal requirements.

The outstanding features of this new X-L tungsten filament considered from the viewpoint of the desirable features of the ideal and in comparison with the old pure tungsten filament are as follows:

- (1) For the same life, the X-L filament can have several times the electron emission, and only a fraction of the same amount of energy is required for excitation. This is best brought out by a comparison between the old UV-201 and the new UV-201-A tubes, the latter tube utilizing this new X-L tungsten filament. This comparison is a convenient one to bring out these points because the two tubes are made to be interchangeable and to operate from the same filament voltage.

Type	Volts	Filament Amperes	Watts	Electron Emission Milliamperes
UV-201	5	1	5	7.5
UV-201-A	5	.25	1.25	45

- (2) The uniformity of electron emission from the X-L filament is the same as from the old tungsten filament. This can be brought out by the fact that in the UV-199 tube, which also uses the X-L filament, measurement of electron emission has been made on every tube leaving the factories. The minimum allowable limit is six milliamperes. The average of thousands of tubes is eight milliamperes, and practically the highest that is found among the standard product is twelve milliamperes.
- (3) Tube noise, a troublesome feature in the older type of tungsten tube, is practically eliminated with the X-L filament, largely because of the much lower operating temperature.

- (4) The feature of increased electron emitting length is well brought out by the following tabulation, again a comparison between the UV-201 and the UV-201-A tubes;

Type	Approximate Life	Filament Length	Approximate Mutual Conductance	Relative Delivered Energy
UV-201	1000	38 mm.	300	1
UV-201-A	1000	48 mm.	475	2

From the foregoing tabulation it will be seen that there is more than fifty per cent. increase in mutual conductance due to the longer filament which allows also the use of larger plate areas. The figures under the column "Relative Delivered Energy" imply that under similar conditions the increased mutual conductance allows the UV-201-A tube to give about double the energy output as an amplifier. The figures for mutual conductance given above refer to these constants measured at rated filament voltage, a plate voltage of forty and a grid voltage of zero.

Probably this feature of increased electron emitting area with the X-L filament can be more clearly brought out by the statement that if an X-L filament tube were built operating at the same filament temperature as the UV-201-A but having the same volts and amperes as the UV-201 and the same life, the electron emission from the X-L filament would be twenty-four times as great and the length approximately double that of the pure tungsten filament.

- (5) The X-L filament has a long life. Life in this case is not terminated by a burnout, but by loss of electron emission. This drop of emission does not occur continuously during the life of the filament, but quite suddenly, and in a very pronounced way at the end of its useful life. The relation between life and filament voltage is not a simple relation, because operation at abnormally high voltage will destroy electron emission which, however, can be renewed by the proper procedure in the hands of the user. This question of life of the tube and the fundamental causes allowing this possibility of renewing electron emission, or reactivation, as it is termed, will be discussed more fully in the following paragraphs.

The electron emission from a given material can be expressed by a fairly simple formula and is determined by two factors, one of which is a constant that is typical of that material and the second is a function of the temperature; the electron emission increasing very rapidly with temperature. In the case of a coated filament, the constant of the material indicates

a high emission, but the allowable temperature is low. In the case of the pure tungsten filament, the constant of the material indicates a relatively low electron emission at a given temperature, but there is the practicability of operating at relatively high temperatures.

It has been found that in general in the case of suitable electron emitting substance the more stable and homogeneous the material the lower the electron emission and, conversely, the lower the temperature at which the material evaporates or disintegrates the higher the electron emission. Another factor found experimentally was that in most cases the more active the material, that is, the greater the electron emission at low temperature, the more subject the material was to loss of electron emission from contamination and insufficient vacuum; certain gases or vapors in particular being very fatal to this electron emission. The problem, therefore, was one of finding a compromise between these divergent factors.

The X-L filament is a tungsten filament in which there is a small percentage, considerably under five per cent. of a material that has high electron activity. This active material in the case of the X-L filament as at present used is thorium and a chemical compound of this thorium is mixed with the tungsten early in the stage of the manufacture of the metal from which the filament wire is drawn.

When the completed filament containing this active material is operated in a vacuum at a certain high temperature, there is a change from the chemical compound to pure thorium. At another certain lower temperature, there is a constant diffusion of this thorium toward the surface of the filament. By this process, a layer of these thorium atoms one atom deep, (and only one atom deep) is formed on the surface of the filament. This atomic layer of thorium is of high electron emissivity so that ample electron emission is obtained from it at temperatures that would give practically no useful electron emission from a pure tungsten filament.

Thorium cannot remain indefinitely, however, on the surface of a hot filament, because in comparison with tungsten, it has a higher rate of evaporation, this rate, of course, increasing rapidly with the temperature. At the temperature at which the X-L filament is operated, this evaporation is relatively slow, but is quite appreciable. The instant that an





atom of thorium evaporates from the surface there is a movement of atoms inside the body of the material which places another atom in the surface layer in the position occupied by the former atom after which movement there is again equilibrium of thorium inside the filament.

A rough analogy to the actions just described is the case of a jar of liquid which is capable of forming bubbles. The production of pure thorium can be likened to the formation of air bubbles at the bottom of the jar and the diffusion of these thorium atoms to the surface of the filament can be likened to these air bubbles rising to the surface of the liquid. As in the case of the thorium atoms, these small air bubbles will distribute themselves so that the entire surface is covered with bubbles one layer deep. If more bubbles are then formed at the bottom of the jar, they will rise until they strike the under surface of the surface layer of bubbles and there will remain stationary and it is possible to thus form a thick mass of the bubbles, all stationary. The evaporation of the thorium from the surface of the filament may be likened to the evaporation of the film of some of the bubbles in the surface layer which causes these bubbles to burst and immediately other bubbles from beneath rise to the surface taking the place of the bubbles just destroyed.

In the case of the filament, the higher the temperature the greater the evaporation of the thorium from the surface which would correspond in this analogy to the bubbles in the surface layer of the liquid bursting at more frequent intervals.

The bubble analogy is in one respect not a good one, and this point is that the volume occupied by the thorium atoms is only a very small portion of the total volume of the material near the surface of the filament, whereas, in the case of the bubbles in the jar of liquid the volume of these bubbles under the surface is much greater than the volume occupied by the liquid. Therefore, in the bubble analogy

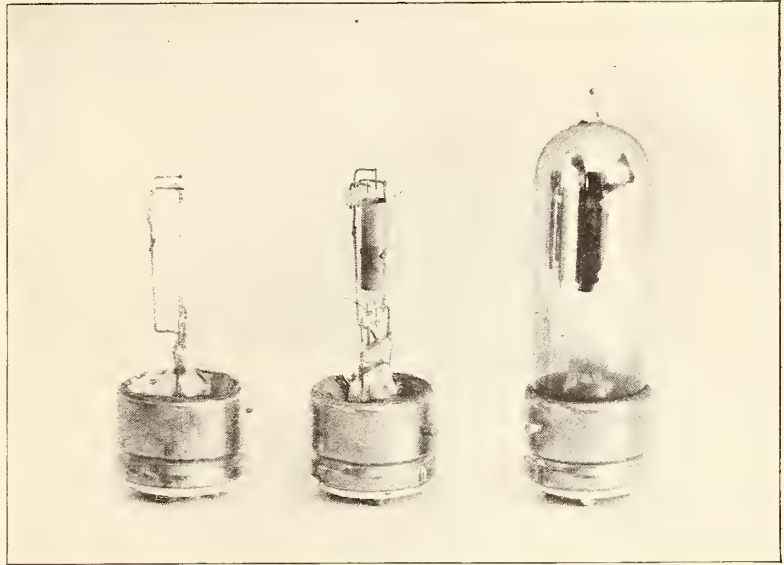

FIG. 1

The UV-199 dry-cell tube. It uses the new thoriated tungsten filament

the layer of atoms one atom deep is not clearly portrayed because the bubbles underneath crowd toward the surface displacing practically all the liquid.

The reactions inside of the X-L filament when operating at its normal temperature are such that the production of thorium in the interior and the rate of its diffusion to the surface are proportioned so that at normal rated temperature they amply compensate for the loss of thorium atoms by evaporation.

There is one effect, however, which tends to prevent the practical utilization of the process in the simple form here outlined.

In an earlier paragraph it was stated that one of the disadvantages of an active electron emitting material was its liability to contamination. This contamination consists of the chemical combination of some gaseous or vapor impurity in the vacuum with the thorium at the surface of the filament, which is emitting the electrons. The X-L filament would be very sensitive to such contamination and this chemical compound formed at the surface by this contamination would not emit any electrons and would require an exceedingly high temperature, up to near the melting point of the tungsten, to remove it and leave free the surface area for the pure active material. Therefore, in the case of the X-L filament, unless some precautionary measures were taken, the electron emission would

last only a few seconds or a few minutes during which time the active surface would become so contaminated that the emission would drop to practically zero.

This problem of keeping the active surface of the filament "clean" was solved by first finding out what the contaminating agents were and then by placing inside the bulb certain substances that would have a more active chemical combination with these contaminating agents than the thorium surface on the filament. The presence of such substances prevents contamination of the filament by previously combining with the contaminating agents. It does not in any way increase the electron emission from the filament directly, but simply protects the thorium film so that the full electron emission characteristic, as would be obtained in practically a perfect vacuum, is more conveniently realized.

Keeping in mind the phenomena just described, the various characteristics of the X-L filament as an electron emitting source are explainable.

For instance, if the filament is operated at an abnormally high temperature, the electron emission at first will be very large, but the higher this abnormal temperature the quicker will this high electron emission fall off until it is below even normal value. This rapid falling of electron emission is due to the fact that the rate of evaporation of thorium from the surface is more rapid than the diffusion to the surface and, therefore, the surface of the filament is no longer covered with the active thorium, but only with pure tungsten, the electron emission from which at a given temperature is far below that from thorium. If then the filament is operated at normal temperature for a short period of time, the evaporation of thorium is reduced to normal and the diffusion from the interior rebuilds the electron emitting layer at the surface. As the surface of the filament becomes more and more completely covered with thorium, the electron emission rises until, when it has become fully covered, it returns to normal.

This brings out the point that there is an optimum temperature for operation of the X-L filament, or more properly speaking, a restricted range of temperature for satisfactory operation. If the temperature is maintained above this range, the electron emission sooner or later falls off as explained, but there is no

permanent injury to the filament unless this misuse is continued, and operation again at normal value soon brings back normal electron emission. If the operation is below this useful temperature range, the electron emitting efficiency is unnecessarily low.

Under rare operating conditions, the supply of thorium in the interior of the filament might become deficient, which would reduce the supply of thorium arriving at the surface and fail to keep a complete layer at the filament surface. Under these circumstances, there is usually still a supply of the thorium compound present which was originally put into the filament metal and by operation of the filament at approximately three times normal voltage for a fraction of a minute there will be a new production of pure thorium. Then, after this new production of thorium has occurred, operation of the filament at normal temperature for a reasonable period of time will cause this new thorium to be diffused to the surface and a new complete active electron emitting layer will be formed.

Also, under abnormal conditions, such as overload of the plate, the contaminating agents may be so plentiful inside the bulb that the substances placed inside to absorb these contaminating vapors and gases may not take them up rapidly enough and so allow a contamination of the filament. Again, the cure for this condition is to operate the filament for a few seconds at about three times normal voltage which decomposes this contaminated thorium from the surface of the filament and then by operation at normal temperature for a reasonable time the normal thorium layer and normal electron emission are regained.

The length of time that the filament must be operated at normal temperature under these different conditions described in order to regain normal emission varies widely, depending upon whether or not the thorium just below the surface has been removed. If the thorium has been removed a considerable distance below the surface, a longer time is required for it to diffuse through this distance to the surface than would be required if simply the surface layer were destroyed. Therefore, if the filament has been operated at an abnormally high voltage for ten to twenty-five hours, it may require this same length of time at normal rated operating voltage in order to obtain





normal electron emission. It is, therefore, apparent that an X-L filament contains a certain amount of stored-up or potential electron capacity which under normal conditions is continuously brought to the surface and utilized in an efficient manner so as to give long life. If abnormal conditions occur, this orderly procedure is disturbed so as to cause a failure of electron emission. However, as pointed out, this potential source of electron emission is seldom permanently destroyed before the end of filament life, and the proper procedure should bring back normal electron emission.

X-L FILAMENT RADIOTRON TUBES

THE Model UV-199 Radiotron tube utilizes the X-L filament and brings out in a most striking manner its unusual characteristics and, therefore, it is of interest to describe briefly this tube and some of its characteristics and properties. The general appearance of this Radiotron tube is shown in Fig. 1. The overall length of this tube from the tip of the bulb to the bottom of the contact pins of the base is  $3\frac{1}{2}$ " and its maximum diameter 1". One of the first features noted in an inspection of this tube is the fact that the bulb is opaque so that the electrodes are not visible. This opaqueness is caused by the materials used to prevent contamination of the filament in the manner previously described.

The outstanding advantages of this new tube are its low filament energy which is only about 75 per cent. of that of any other tube in use at the present time, its small size and excellent detector and amplifier characteristics.

The filament is operated at three volts and requires only sixty milliamperes.

The tabulation shown below indicates what service can be obtained from a set employing one, two, three, or four of these tubes in parallel operated from three good quality No. 6 dry cells connected in series. This tabulation is based on the use of the tubes two hours out of each twenty-four hours.

No. of tubes in set	Total hours	Days	Months
1	387	193	$6\frac{1}{2}$
2	200	100	$3\frac{1}{2}$
3	126	63	2
4	92	46	$1\frac{1}{2}$

The extremely low filament current of this UV-199 tube makes it possible to operate from flashlight cells. Operation from such

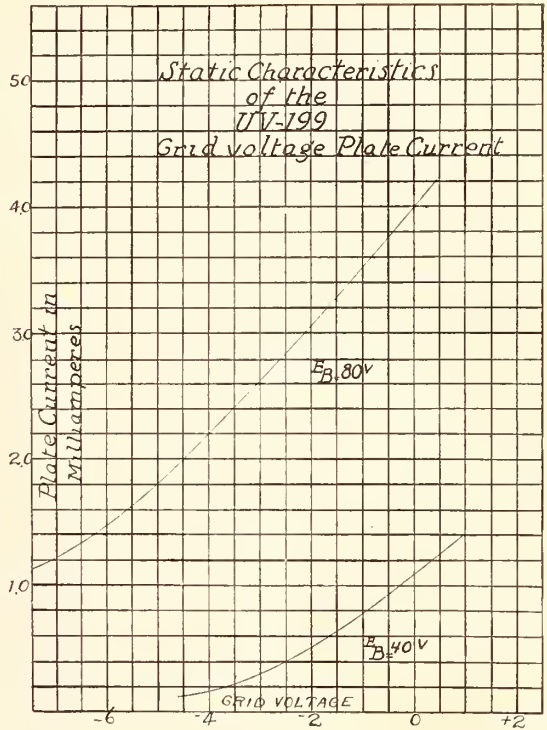

FIG. 2  
The "characteristic curve" of the UV-199

small size cells is not as economical as from the six-inch size of cells. However, for portable equipments, this difference is more than offset by the light weight and small size of these flashlight cells.

One UV-199 tube may be operated from a three cell flashlight battery one hour out of each day for a little over a month. A longer period of daily operation than one hour will shorten somewhat the total useful battery life.

For portable sets containing more than one UV-199 tube one three cell flashlight battery should be used for each tube operated. Operation of the filaments of more than one tube from a single flashlight battery is not only poor economy, but the voltage drop of the cell while in use under this heavier current drain is after a short time so rapid that operation of the set is unsatisfactory.

This size of unit flashlight cell is approximately  $1\frac{3}{8}$ " in diameter and  $2\frac{5}{16}$ " long. Smaller sizes of flashlight cells have not been found satisfactory for use with these filaments, because not only is the economy poor but their voltage drops so rapidly that in a regenerative circuit difficulty is experienced in satisfactorily holding an adjustment.

29

This use of flashlight cells combined with the small size of the tube gives the possibility of making up extremely sensitive, small, and light weight portable receiving equipments.

The characteristic curve of this tube is shown in Fig. 2, and is very similar to that of the old UV-201.

In this connection, it should be kept in mind that the UV-201-A tube has a higher amplification constant and lower impedance than the UV-199 tube, and, therefore, has a greater mutual conductance so that it is inherently a better amplifier. This is to be expected, because the UV-201-A requires almost seven times as much filament energy and has bigger electrodes of the UV-201-A and the fact that it can be operated at a higher plate voltage than the UV-199 combined with its better characteristic curve make it a much better tube to use for the operation of loud speakers where an exceedingly large volume of sound is required. However, where it is desired to build a multi-tube set, the UV-199 is, of course, superior because a dry battery can be used for the filaments, whereas, the same number of UV-201-A tubes would make dry battery operation rather out of the question.

The UV-199 tube is also very suitable for radio-frequency amplification, because the capacity between electrodes, owing to their small size, is considerably below that of any other tube available to the experimenter at the present time. To get the full advantage of this low capacity, a socket designed for the tube rather than an adapter to a standard socket should be used. Attention should also be directed to the set wiring so as to keep capacity effects at a minimum.

The arrangement of the contacts on the base of this UV-199 tube (Fig. 3) is not the same as in the case of the standard bases. This change has been made so that the wiring of the filament leads as well as the plate and grid leads can be more conveniently arranged and with less capacity effects between them than in the former pin arrangement.

One of the principal precautions to be observed in the use of the Radiotron Model UV-199 is to be certain that the rheostat used

is such that the voltage of the filament source can be reduced to the proper value of three volts for the filament.

Inasmuch as three new dry cells for a very short time have a voltage of 4.5 volts, this means that 1.5 volts must at first be absorbed by the filament rheostat. A filament rheostat of thirty ohms maximum resistance is recommended for a single tube. In the case of two tubes, the filaments of which are in parallel and controlled from a single rheostat, the resistance should be fifteen ohms, and in the case of three tubes, ten ohms.

If for any reason it is desired to operate these tubes from a three cell storage battery and a connection for the voltage from two cells cannot be obtained, the rheostat resistance should be at least sixty ohms for one tube, thirty ohms for two tubes, and twenty ohms for three tubes.

In a great majority of cases, if due to improper operation these tubes show low electron emission, this electron emission can be regained by operation at normal filament voltage for a period of time roughly proportioned to the time during which the tubes were operated at an over-voltage. It is preferable during this reactivation of the filament and often hastens its

recovery to disconnect the B battery so that there is no plate voltage on the tube. If this treatment fails to reactivate the filament, the tube filament may be flashed at eight to nine volts for about ten seconds and followed by a run of several hours at rated voltage. This should, in practically all cases, cause the return of normal electron emission. These methods of reactivation will not, of course, be successful if the tube has run its normal life or has been consistently operated at excess temperature or misused.

Under normal operating conditions, these methods of reactivation are not necessary during the life of the tube.

Many modern vacuum tube receiving circuits are of extreme sensitivity, and vibration often causes the tube to introduce into the receivers a disturbing sound. This is termed microphonic effect of the tube and is a factor which must be taken care of in multi-tube UV-199 circuits in the same way as it has been



FIG. 3  
Showing arrangement of contacts on the UV-199



taken care of in the use of other tubes, that is, by proper cushioning of the sockets.

A plate voltage higher than that obtained from four standard block cells should not be used on this tube, as it reduces seriously the factor of safety against overload and will shorten the life. With eighty volts on the plate a negative bias of three to 4.5 volts should be used on the grid. This is conveniently obtained by two or three small flashlight cells.

It is an interesting fact that with a plate voltage as obtained from four block cells and with the proper negative bias, the plate current is approximately 2.5 milliamperes which at eighty volts gives a dissipation of energy on the plate of approximately .2 watt. As the normal filament energy is only .18 watt, this fact that the plate energy is more than the filament energy is rather a striking example of the great improvement that has been made in these tubes in regard to filament operation and electron emitting efficiency.

A fairly comprehensive examination of tubes that have become inoperative due to actual filament burnout has disclosed the fact that a very large majority of these tubes were burned out by the filament becoming connected across the plate battery. It is a common custom, but dangerous to the tubes, to make changes in the wiring or connections of the set while it is in operation or while the tubes are in the sockets and the B battery in circuit. A mistaken connection which puts the filament of a UV-199 or UV-201-A tube across a B battery

of forty volts or more that is in good condition usually destroys the filament so quickly that a flash is not noticeable unless the tube is directly in the line of vision.

In view of these facts, it is particularly to be urged that wherever possible tubes be removed from their sockets or the B battery disconnected while experimenting with the circuit arrangement. An even preferable arrangement and one which allows the convenience of trying various arrangements without the preceding precaution is to insert in one lead of the B battery at one battery terminal a ten-watt, 110-volt Mazda lamp. The cold resistance of such a lamp is so low that in the great majority of circuits there will be no ill effects, but such a lamp has the valuable characteristic of increasing its resistance so that at operating temperatures it is ten or twelve times as high as when cold. A ten-watt lamp used in such a manner even with a plate voltage of eighty or more will limit the current to less than 100 milliamperes which can do absolutely no harm to even such a small filament as that used in the UV-199. A lamp used in this manner also is convenient in that it shows up, by the filament becoming incandescent, a B battery short circuit or leakage that might otherwise go unnoticed and very quickly run down this battery.

The X-L tungsten filament is not only useful in receiving tubes, but is alike applicable to the smaller sizes of transmitting tubes, resulting in a much lower requirement of filament energy.

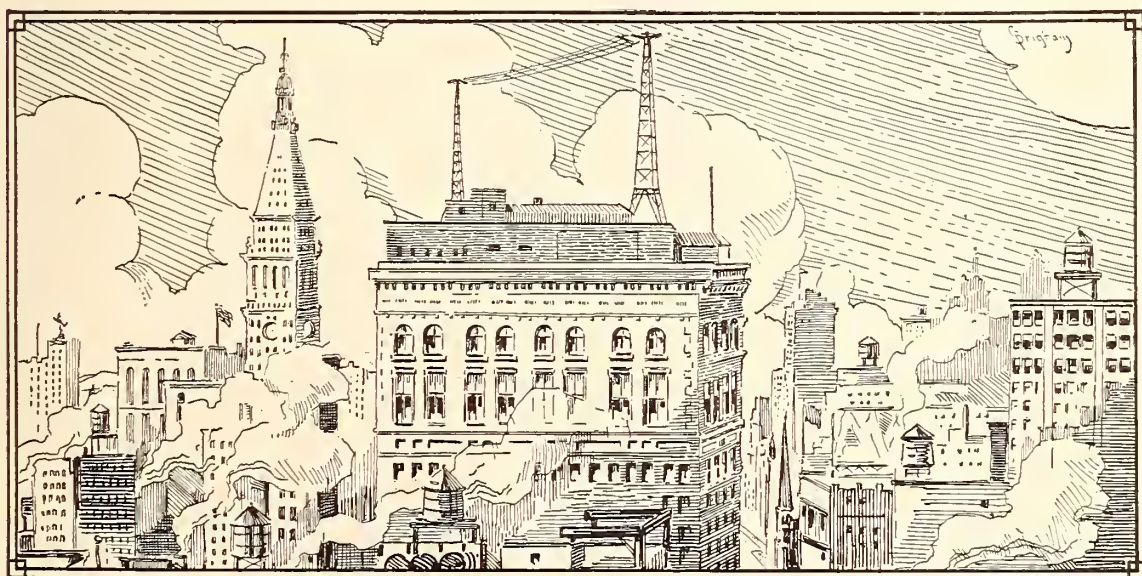

# 10,000 Miles of Radio Lectures in China

By C. H. ROBERTSON

Science Lecturer, Educational Dept., National Committee Y. M. C. A. of China

Back in 1902, Professor Robertson was asked to give up his work on the Engineering Faculty at Purdue University and go to China to carry on, under the auspices of the Y. M. C. A., the work he had been doing in the United States. Except for the war period, when he was on a special mission in Russia and Siberia, Professor Robertson has spent most of the intervening years in China. Concerning the purpose and results of these years of work in the Orient, he said, in 1920: "I have been back on the field but four months after returning from furlough, and perhaps the most encouraging thing has been the constantly increasing industrial development in mining and manufacturing. In all this, the Association (Y. M. C. A.) has been a constantly increasing factor in *helping the people to assert themselves*, in pointing out and studying new and difficult problems that the rising industrial life presents, and has been particularly helpful in encouraging right educational ideals and methods. In the face of these and other things, there should be no retrenchment, we should advance."

Professor Robertson's account of his radio lectures in China is especially interesting as a revelation both of the widespread interest in modern scientific progress evidenced by Chinese of intelligence, and of the rapidity with which knowledge of radio communication is being assimilated and turned to practical account.

—THE EDITOR.

**T**HE radio telephone as a lecture subject has gripped China more powerfully than any other subject in the twenty years of lecture experience of the writer in the "Middle Flowery Peoples Government Country."

The first radio lecture was in Tientsin in 1906. The audience was the staff of the great Government Educational Museum, established in a confiscated temple. Building after building had been filled with modern educational equipment of the Western type to supplant the recently abolished "Literati" or classical educational system dating from before the time of Columbus. A part of this equipment was a wireless telegraph station. No one on the staff knew how to operate it, and so, at their request, the writer put it in order, gave them a lecture and started this group in radio.

Later, the writer constructed, in the "Y" Lecture Laboratory at Shanghai, a spark station

that was completely dissectible and connectable in a great number of ways. This did several years' service until superseded by a modern vacuum-tube outfit.



PROFESSOR ROBERTSON'S LICENSE

Title page of document issued for radio lecture campaigns. As will be noted, this is "Number One." It happens that Dr. Robertson holds another "One", also issued by the Republic of China, with a date ten years earlier—in 1912

## THE PORTABLE STATION RECENTLY USED

**T**HIS station (shown in the picture on the opposite page) was used in the Victory Day celebration in New York in 1919, and a year later was built into a traveling lecture unit in our Shanghai Laboratory. It has power, sending, receiving, and amplifying units. It uses two five-watt W. E. "E" power tubes, one as oscillator, the other as modulator on the Heising system. For reception W. E. "J" tubes are used, a detector and two stages of audio-frequency amplification. For the loud speaker three stages of amplification are added, the last through an "E" tube to handle the greatly increased energy. The panels turn back and down into the base which shuts up like a jack-knife, completely enclosing the panels. The tables



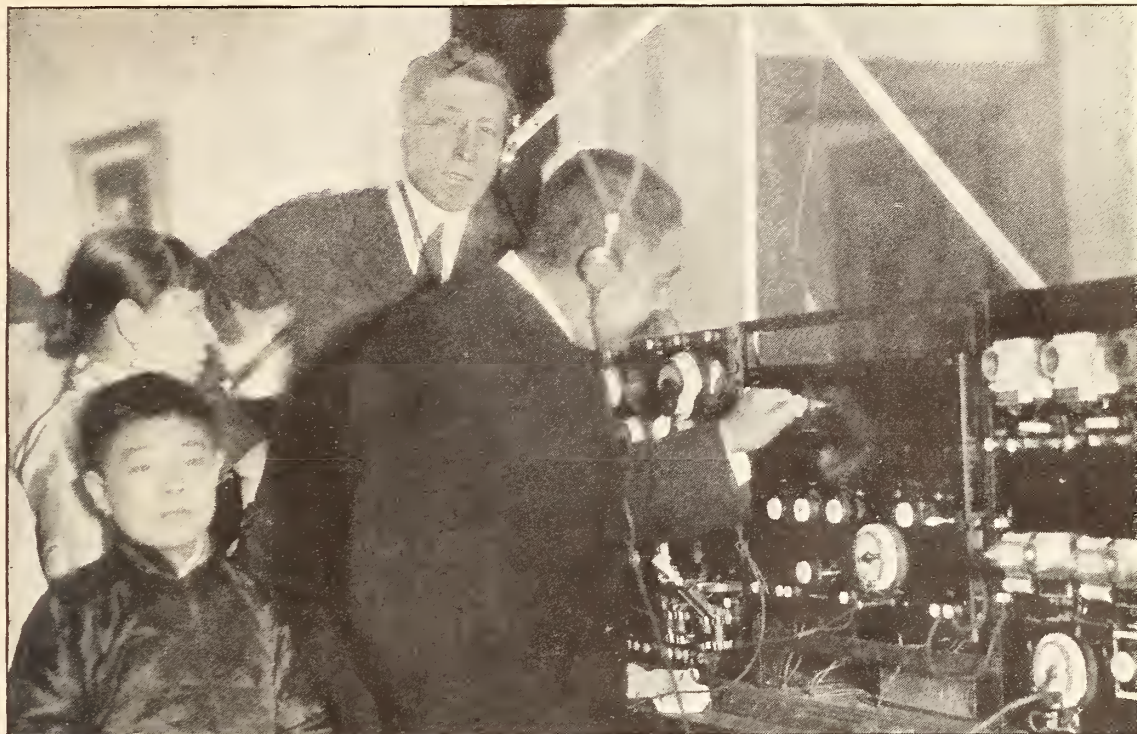

LI YUAN HUNG, RECENT PRESIDENT OF THE REPUBLIC OF CHINA, AN ENTHUSIASTIC PATRON OF THE POPULAR SCIENTIFIC LECTURES

He is shown with his son and daughter and Professor Robertson. The apparatus in the picture was built for this lecture work and was mounted on panels so as to be accessible from front and rear, allowing every detail to be followed out. Two 5-watt tubes were used for transmitting, and for reception, a detector and two stages of A. F. amplification were used, three more stages being added when the loud speaker was employed

in front turn back and lock together making the cover, and the outfit becomes a strong trunk ready for the road.

The energy is supplied by two 175-ampere storage batteries which in turn drive a motor generator giving 350 volts plate current. A suitable switch enables one voltmeter to read all pressures. All supply current passes through one ammeter, so by subtraction, the consumption of any unit of the station is determined. The station can be opened or closed in about ten minutes. A folding frame giving a 10-foot square loop provides for short distance transmission and reception, while a switch throws over to an antenna with which long distances can be had on both transmission and reception. An exact duplicate of this station in another trunk provides for complete two-way demonstrations over short or long distances.

This quite possibly was the first radio telephone station mounted on a Chinese wheelbarrow, and in this form our preliminary tests were made between the laboratory and various

positions on the streets of Shanghai. The temporary loop may be seen supported by the mast from the front end of the barrow (page 384.)

On the opposite page is shown the title page of the amateur license issued to the writer. Of course all the lecturing has to be done in Chinese. The radio lecture generally begins: "Wo-men chin-tien wan-shang-ti ti-mu shih wu hsien-tien-hwa." "The subject of our lecture to-night is the radio telephone."

With the portable apparatus described, we started down the hundreds of miles of coastline to South China and began at Hongkong. The British Navy gave fine coöperation and we installed our broadcasting station on one of their cruisers. To our delight, we found that it worked across the spacious harbor and could be amplified and made clearly audible to the large audiences gathered in the "Y" auditorium on the precipitous mountainside upon which the city is built.

In Canton, the first lecture was before the



officials of the South China Government. Our old friend, Premier Wu Ting Fang (whom many of you will remember as China's Minister to America) was present and just as keen and penetrating in his questions as when he fascinated so many American audiences in years gone by.

The Canton "Y" has a fine new plant, and to the auditorium came three audiences per day. Of all I enjoyed none so much as the group of seventy students in a technical series on "Radio," with a view to the further development of the spirit and method of science in the city of Canton.

At Amoy, the smallest city on the whole trip, C. J. Wang, the able Chinese Secretary, and John Bradshaw, his American associate,

have a tremendous grip on the town. They put up a special auditorium seating over 2,000 people, and to this on one day came 7,800, with a total for the first four days of 17,800, supplemented by a later four-day campaign of over 10,000, making a total of more than 27,000 people. Not only were there large numbers, but the character and appreciation of the audiences were of a high order.

A unique event was made with the cooperation of the Chinese Navy, on a cruiser on which we installed our broadcasting radio-  
phone. The other apparatus we erected seven miles up the bay at a new educational centre called "Chi Mei" (The Assemblage of the Beautiful). Here I was privileged to speak to an audience of 1,600, and great was their delight to hear the voice of my associate, Mr. Han, and then a musical program coming across the seven miles of mountain and sea.

The occasion was the opening of a new department of what is building into Amoy's two million dollar University, the gift of Mr. Tang Ka Ki, now a wealthy rubber grower who, in times of business depression, has even worked as a ric-sha coolie, and who, out of these great octaves of humanizing experience, is now devoting himself and all that he has to the putting forward of education in his native province after years of strenuous business at Singapore.

In Foochow, I found my old friend Governor Li Hou Chi. He was immensely interested in the lecture message. He appointed his chief officials to attend, got up a fine dinner in his palace, urged me to get to him as soon as possible data for linking up the different cities of his province by wireless telephone, and then provided a contribution sufficient to cover the local expenses of the lecture campaign.

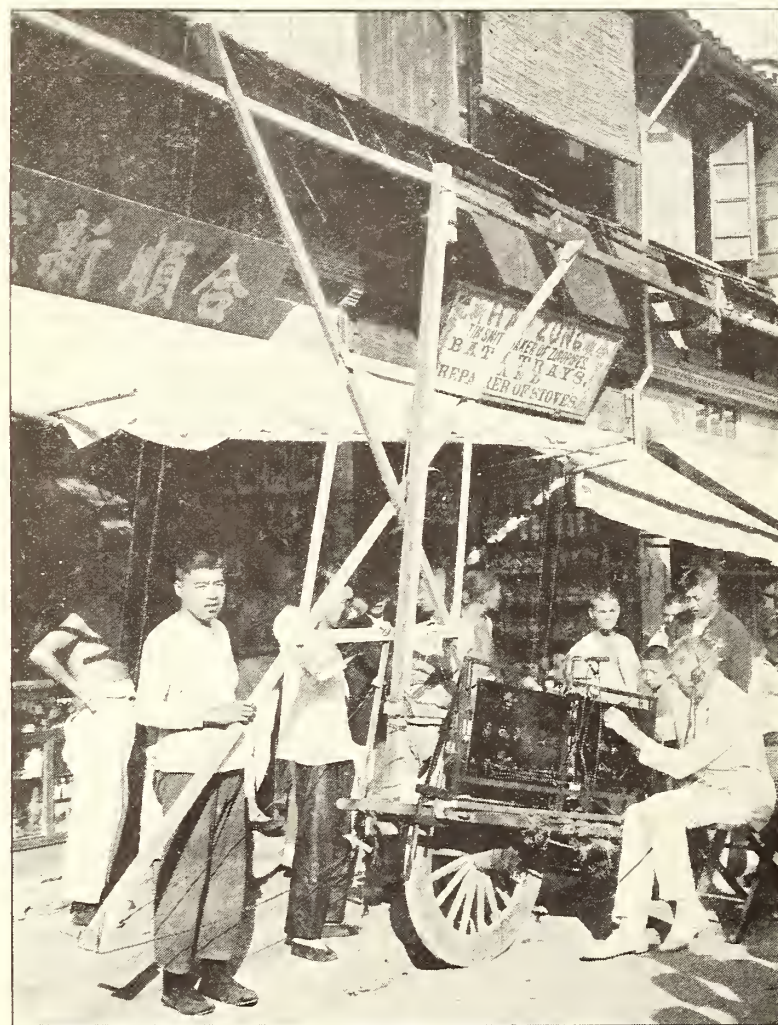

EXPERIMENTING WITH A LOOP TRANSMITTING AND RECEIVING STATION IN SHANGHAI



But even greater was the appreciation of a mission college student who sat in the front seat at every lecture and afterward wrote: "O! my teacher. I am very grateful toward you for having come to us. I have got lots of things from you. My schoolmates wish me to speak on what you have taught in the special wireless telephone class, so may I see your book on the Audion for I not yet understand it. I desire to be your student or servant after have graduated from college this year, whereby I have the opportunity to learn from you the electricity. . . . You are very kind and have done big service." How many others were interested as much as this young fellow I do not know, but that it was a great many I am sure.

#### A TRIP TO THE NORTH

**I**N PAOTINGFU is the great Military Academy, the West Point of China, and it was a fine show to see the 1,200 students come marching through the city as twelve companies of one hundred each. Their officers all came to the stage and examined the equipment, and



PROFESSOR CHARLES H. ROBERTSON

then we had a most appreciated presentation, ending up with exchange of messages with one of their wireless telephone squads outside the East Gate. Each following day they brought the whole radio corps to the technical lectures, and good times we had! The initial meeting was followed up by two big audiences each day from the schools, merchants, gentry, and other classes of that interesting old capital.

The unusual campaign in Peking was initiated by working day and night in the laboratory of the China Electric Company, where, with the help of their radio engineer, Mr. F. R. Lack, our equipment was brought up to date. The meetings were held in that fairy-land-like group of buildings, in the centre of the city, that has been erected by the Rockefeller Foundation for the Union Medical College. It ranks high among the medical training institutions of the world, and in its beautiful auditorium all the meetings of the Peking campaign were held. But better even than the fine surroundings was the coöperation of the Peking Board of Education in gathering the audiences, made up of picked students from about fifty of the schools and colleges of the city.

After a long trip through the wide plains of Manchuria we tackled the Yangtze Valley.

Our ton of radio and lecture equipment was put on board the steamer *Kiang Shun*. . . We



C. H. HAN DEMONSTRATING MONORAIL APPARATUS

Mr. Han has been associated with Dr. Robertson for 18 years



started up river at daybreak. Plains gave way to mountains, and steaming by pagodas, lumber rafts, sailing junks, big steamers, and many walled cities, we debarked four days later, six hundred miles from the sea on the wide swift flowing Yangtze at Hankow, with waves so big that my demonstrating mechanics were sea-sick as we shifted by sailing junk to a Japanese steamer for the next leg of the journey to Changsha.

We crossed the Tung Ting Lake, the "Bull's-eye" of China, and after an all-day run up the beautiful Hsiang River, arrived at Changsha (Long Sand), the thriving, bustling capital of the agricultural and mining province of Hunan.

We had to hustle to get our radio telephone stations up and working for the official meeting at seven o'clock with Governor Chao Hung Ti in the chair, and the principal high officials and gentry present. It was an appreciative audience, and the Governor was especially gracious. We effected a fine exchange of messages with the American Navy ship *Villalobos* (One of

Admiral Dewey's prizes from the Battle of Manila Bay). Our radio reached through to them strongly and their signals were amplified by our receiving set loud enough for an audience of 50,000 people. When the meeting ended, I took the Governor for a look at our auxiliary radiophone in a closed room on the other side of a big compound.

When we were through, I escorted him to his sedan chair at the door. He was soon seated and I followed, according to Chinese courtesy, to the gate. He had just gained the street, thickly surrounded by his armed body-guard, when—*Bang!!*—a heavy explosion, and I saw the chair careening through the smoke, and stepping over the threshold found nine wounded people moaning and crying on the stone flagging, from the missiles of the bomb thrown from somewhere in the darkness. The soldiers grabbed the shafts and got away with the Governor unharmed to his palace. Later we learn that seventeen were wounded. One of his chair coolies died shortly after. How harrowing an experience this is one doesn't

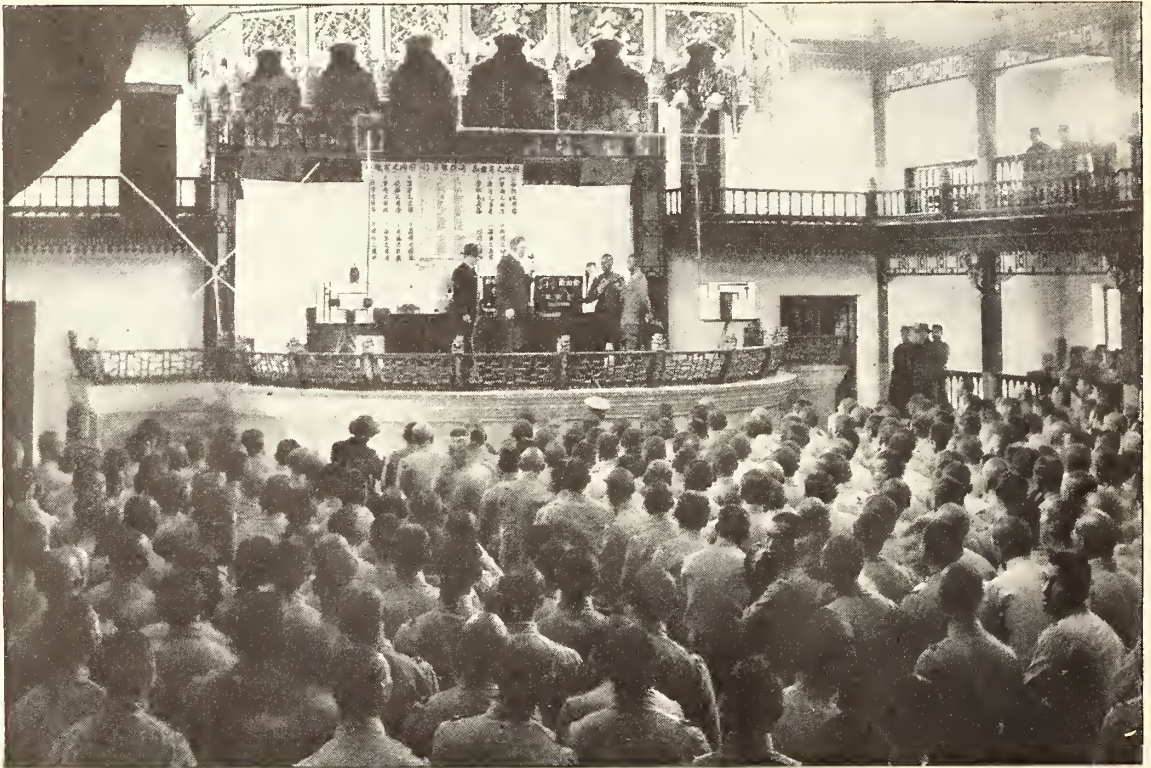

CADETS OF THE WEST POINT OF CHINA IN THE TEMPLE OF THE GOD OF WAR IN PAHOTINGFU  
Two officers of the Military Radio Telephone squad are on the stage. The charts in Chinese at the back of the stage summarize the applications of radio. During the last two years four hundred such audiences have gathered for these radio lectures in China





PART OF AN AUDIENCE IN FOOCHOW

This was a combination meeting, at which Eddy spoke on religion and Robertson on science

realize until, after having gotten the wounded on stretchers to the Red Cross Hospital, one washes off the blood and grime and turns in late at night.

The next day the pressure began. Popular lectures at 10:00 and 4:00, technical radio

lecture at 2:00 and science and religion forum at 7:00 with an attendance for the day just beyond 3,000. There was a keen interest shown by the audiences and fine coöperation by Kallam, the American navy operator who was with us. He especially appreciated the en-



FOOCHOW OFFICIALS WHO ATTENDED LECTURES BY PROFESSOR ROBERTSON





AN OFFICIAL RECEPTION BY THE MILITARY AND CIVIL GOVERNORS OF KIANGSI PROVINCE

thusiastic applause of the audience transmitted to him by radiophone, and replied with an apt Chinese phrase—"Ting Hao" (Very good).

On the last day of our tour came a final address before a group of faculty members of a great Chinese college. Paul Kwei, Head of the Department of Physics, got his big impetus for scientific educational work in two of our lectures in St. John's University at Shanghai, ten years ago. The total attendance in Changsha was 16,705.

A trying twenty-hour railway trip in day coaches brought us back again to Hankow, just in time to catch the night steamer for Kiukiang, twelve hours down, and there we made close connections for the train to Nanchang, the capital of Kiangsi, seventy miles interior on the south bank of the river.

Again a week of eager faces, and I found a Purdue-trained engineer, C. E. Draper, arranged to take charge of the students from the technical radio series part of the program and to lead them in their studies in actual experimental contact with this fascinating subject.

Twenty-four hours down river brought us to Anking, the proud capital of Anhwei Province. Here we found the American Navy Flagship *Isabel* equipped with a radiophone, so we had

beautifully clear communications by voice, as well as by telegraph, to the immense delight of the audiences in the provincial educational Association lecture hall.

Another week of eager faces—three meetings with Governor Hsu, an old-time friend, and his official family, a three-page poem in Chinese from one of the auditors, and we started with light hearts for a sail past a mile-long flock of wild ducks down the Yangtze.

Here we arrived home in Shanghai again; and a strenuous time it had been. The cities visited were twenty-seven, the distance more than 13,000 miles, and the attendance 184,242. Not only were there great numbers but also personalities. Twelve provincial Governors and twenty-five national and ex-national officials, including two national ex-presidents, graced the meetings with their presence, and were stirred by the vision of science in the future of China, and of the contributions to science in the world that China would sometime make.

A friend said: "It looks easy, but we know it is not." And that is the truth. The journeys took us into four main regions of China. In one were bandits, in another famine, in the third pirates and in the fourth mutinous and looting soldiers. Shortly after I left the City of



Wuchang, the "Long" street was looted and burned. The Governor permitted the looters to get away, but laid an ambush for them on the railroad, and when their long train pulled in, turned on the artillery and shot the train and its contents to pieces.

#### A RADIO TRIP TO THE MANCHURIAN FRONTIER

**A**FTER a series of travel adventures on the disorganized railways of China, early this year, I drew near to Mukden. Major Gao, aide of General Chang (whose guest I was to be in Mukden), met me two stations out and on disembarking I found motor cars and army transport waiting.

In a motor placed at my disposal for the visit, and in the crisp, sharp northern winter morning I went to the provincial assembly building. The army radio telephone corps had erected the antenna masts. In less than an hour we were set up, all ready for the lecture except for the testing. Throwing in the switches, I said: "Wo-men tsai che-pien hswo hua ni-men tsai napien ting teh lai la ma"—

"We here speaking you there hear, eh?" Immediately came back the reply from their radio corps in a temple outside the city: "Wo-men che-pien ting teh heng hao"—"We here hear extremely well." After a little more testing, they said: "If you will listen in we will call Chang Chun." I heard them calling and in a moment back came the reply from Chang Chun, 200 miles away.

At 10 o'clock in came my first audience, a half regiment of sturdy Manchurian soldiers. We had a fine time together! Immediately following this, came the first of a series of eight daily lectures with laboratory work for the radio corps.

That same afternoon, came a group of



THE GOVERNMENT RADIO ENGINEERING SCHOOL AT SHANGHAI  
In the centre, "X", is Professor T. C. Chang, Dean of the School. With him are some special radio students. The building is finely equipped with class rooms, and "labs," and an operating room in which are various types of phone and telegraph sending and receiving apparatus

important business men gathered by Joe Platt, our wonder-working "Y" secretary, who is so esteemed in Manchuria's capital. In the evening a small group gathered in General Chang's headquarters office, made up of staff officers and influential civilians, for an informal chatty hour. Some subjects discussed were 1, The Stroboscope and Its Revelations; 2, Glimpses Into Astronomy; 3, Molecular Motions; 4, Curious Right-angle Gyroscopic Reactions; and so on for eight days in succession!

The life of Mukden often reminded me of pioneer days in the Dakotas. It is an immense prairie land bordered on the east by the Pacific, on the west by mountains and deserts



THE "BRIDGE OF TEN THOUSAND AGES" AND FOCHOW HARBOR—

A typical panorama of the "old and populous land," which, according to Professor Robinson, is now beginning—

and on the north by the great rivers and forests of Siberia. The streets are crowded with traffic coming in from the country, big two-wheel carts (rims recently broadened by law) drawn by three to six horses. Markets filled with furs from muskrat to tiger. One day my soldier-audience failed me. They were out suppressing a bandit uprising. Everywhere a great stir of life. Plans for agricultural development on quantity scale, companies for exploiting forests, promoters of mines, of electric-service monopolies and of new railways. I felt I ought to be staking out a claim, organizing a lumber camp or opening a mine!

On the last day General Chang gave us and his staff a banquet in the great North Camp four miles out. It was a stinging cold day, yet the big military band marched out for the occasion. The next morning, escorted again by the ever-courteous Major Gao, we got our 1,500 lbs. of lecture equipment on the train and started back again for the Yangtze and home.

It was a great experience, but of it all nothing seemed to me more significant than the quiet evenings with General Chang and his keen, intelligent group of officers, holding informal discussions on science, on religion, and on the moral issues of life. They all seemed to enjoy it immensely, and so did I. How much all this will count in the potential struggle between Russia, Japan and China of which Manchuria is the future stage, I know not, but that it was in the right direction, and that it has given another link with some of the personalities that will loom large in the future of China, I am confident.

Without doubt, the greatest handicap to the progress of radio education in China to-day is the bureaucratic monopoly of the military

party who have not yet raised the war embargo against the importation of radio equipment into China. It took me no less than two months to get through the Customs at Shanghai the lecture equipment for educational purposes—and then only after special authority had been secured from Peking.

One of our keenest supporters and patrons has been President Li Yuan Hung. Our first meeting with him in our lecture work came when, as a Colonel of a local regiment in Wu-chang, in 1911, he attended a science lecture. A few weeks later he was instrumental in starting the revolution that upset the Ching Dynasty after its 267 years' rule, helped to establish the Republic of China, became its first Vice-President, and then President of China.

In the early days of the lecture work, it was extremely difficult to secure the coöperation of American business men and firms. Not so, however, with the Germans, who through their agents in China were glad to provide fine coöperation in equipment and publicity. A visit of the writer to America in 1919 helped to increase American support. There is need however, of far greater foresight and vision and more extended coöperation of American radio and scientific organizations.

Returning to Shanghai I found that "broadcasting" had arrived and was producing that tidal wave of interest and enthusiasm with which all of you in America are so familiar.

Now is the time for constructive propaganda; a Radio Corporation broadcasting station has been started in Shanghai, and daily programs of Western and Chinese selections are sent out and the same great enthusiasm and unanswerable demand for receiving equipment has





—WITH KUSHANG MOUNTAIN IN THE BACKGROUND

—to throb with interest and activity in applying the fruits of modern science to its social and industrial life

developed in Shanghai that so many of you are familiar with in America.

In getting ready for big developments, it is the plan of the National "Y" Educational Department to initiate special training insti-

tutes with the provision for amateur teacher training, literature supply, equipment, etc., so that there may increasingly come to China the great blessings that radio will engender in this old and populous land.

## Wanted: A Desert Island!

The Story of an Attempt to Forget Radio and All Its Dreadful Associations

By ZEH BOUCK

**T**HERE was a time, when to isolate myself from radio—from its inducements and extravagances—was farthest from my desires; and occasionally, even now, I am not altogether antagonistic to it. I don't mind writing a radio article now and then—it returns to me a fraction of the money I have squandered on everything from coherers to power tubes—or listening-in once in a while to WLC handling traffic in a way that shakes the dust from a thousand memories!— But one can have too much of a good thing, and the time came, not very long ago, when radio and I decided to see less of each other (I'd laugh, were it not so tragic!).

After disposing of a motor-generator and sundry apparatus, I presented an incipient lunatic next door with my antenna, on condition that he swing the unsightly lead across the courtyard into his own window. Feeling more or less like an emancipated drug addict, I looked forward to an enjoyable freedom. But I was sadly mistaken. Generosity may be a virtue—but virtue has always been my stumb-

ling block. My neighbor apparently considered that services went with the aerial, and he dogged my steps and my telephone with an implacable demand for a crystal regenerative set! With the usual malignancy of neighbors across the court, he recommended me to some dozen of his fanatic friends, with the result that instead of being divorced from radio I was all the more embroiled in its iniquities! Deciding to finish my next door neighbor once and for all, I sold him an electrolytic interrupter with which to light his filaments. When his three tubes blew out (as I knew they would the second he turned them on), instead of being disgusted and forever through with me, the leech came around and demanded, not my life as I had hoped, but a scientific explanation of why his tubes had blown!

That finished me—pitifully so. I determined to leave the city, to seek new parts, (no, no, I mean new places), some virgin land; vowing to shun radio in every form however innocuous it might appear! But the question was, *where* to go; in what direction lay my escape?

"Finding an unpolluted spot is going to be

like searching for a catwhisker in a haystack!" I thought; which paraphrasing of the old aphorism well indicates my disordered state of mind.

*Haystack!* A-a-ah! The very thing! Back to nature—farm-life, cows, sleepy pigs—back to those far regions where they have yet to learn the value of silos as antenna masts! And visualizing the peace and antiquity that I desired, Schoharie, N. Y., my ancestral village, flashed to mind. Schoharie, backward and somnolent, lying in the valley of the same name, between slopes that farther south and east run into the less lazy majesty of the Catskills. Schoharie! A great soft country, like a sleeping cat, indolently beautiful, with hills of green and tilled gold squares isolating it from "civilization." Down in the centre of the valley runs the twisty, slow Schoharie River, emptying later into the Mohawk, and beside the river, the twisty, slow Schoharie train. In my mind's eye I saw myself alighting from that train at the little station. . . .

Without more ado I telegraphed the Mackeys, with whom I had previously boarded. It was not until I had finished packing my bag that I noticed that I had thrown in a pair of phones, by force of habit.

The next day, on the observation platform of train 51, I breathed a sigh of relief as she slowly pulled out of Grand Central Terminal. Good-bye to radio! But fifteen minutes later I was dizzy with counting antennas! I was actually ill by the time we passed the old De Forest tower at Highbridge. As we sped through Yonkers, I cast a final, half fascinated glance at a huge umbrella type aerial (2ZS, I think), and turned to my paper, carefully folding *inside* the page that gave the broadcasting programs.

At Albany, I changed to the Binghamton

Local, a fairly comfortable train when stopped at stations, or, as is quite often the case, between them. I had barely settled myself in the old D. & H. smoker, when a native son of the soil dropped into the seat beside me. I wiggled over to the window, partly to give him room and partly to escape the hazard of a heavy basket which he balanced on the rack above me. My companion looked me over with disconcerting deliberateness, and taking a preliminary chew from a package of Old Cottage, spat and spoke.

"Going out far this way?"

I beamed on him with a sudden realization of where I was. At last I could converse with some one in a language in which "coil" could mean rope and spaghetti was something to eat.

"Oh not very far. I'm getting off at the Junction. It's a great free country out here!"

"Uh huh," and he chewed away unimpressed, for all the world like the ruminating stock he doubtless owned. He evidently figured it was my turn, so I ventured:

"Goin' very far yourself?"

"No, I'm jest going to Delanson."

"Delanson, eh? You don't happen to remember Dick Mackey, do you?" Dick, years ago, had there propertored the best hotel in the county. He taught the bartender the ramifications of his art, until his license was voted away, when he took to farming.

"Dick! I should say I do reck'lect him. Beint he up in Schoharie now?"

"Right-o. That's where I'm going. . . . Out on his farm."

"Yep, Dick's a good fellow. D'ye know Russ Deyo up in Schoharie?"

"Russ? Sure! He has the Ever-ready Storage Battery agency, hasn't he?"



I CAUGHT A GLIMPSE OF JED WILKINS IN THE EXPRESS OFFICE



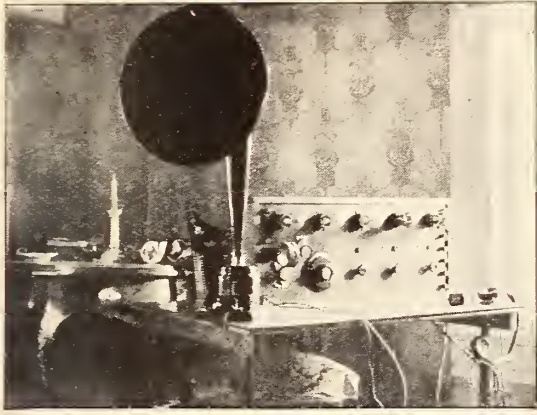

RUSSELL DEYO'S FIVE-BULB SET  
Which gave the writer a surprise

"Reckon he has. Russ is a lively boy, Russ be. Got one of these here radios now, and he's selling 'em all over the county. Farmer down by Delanson got one the other day offin him!"

My heart sank. I made a mental note to keep away from Russ Deyo. It was a darn shame, too, for we've always been the best of friends. "Radio all over the county!" That was discouraging. Well, anyway, I knew that Dick had two hundred acres of virgin hillside, and I consoled myself with the thought of my coming isolation.

Then my curiosity, whetted by fourteen years' environment, got the better of my discretion, and I asked:

"What do you farmers think of this radio, anyhow?"

"Well, to be frank with ye, we don't think a hell of a lot of it——"

I nodded and beamed approvingly, almost asking him for a chew of tobacco.

"Well," I pursued, "doesn't it do you any good? Don't you derive any benefit from the market quotations and the crop reports, and all that sort of stuff? There's the weather forecasts—and then, don't you enjoy the concerts?"

"Weather reports? Huh! I reckon I kin gen'rally figure out the weather 'thout anybody's assistance. The music's all right for them as likes it. My wife, she kinda takes to sech tripe . . . but then she ain't responsible. And then that there crop report. Well, half the farmers don't get it anyway, 'cause it's sent out at the wrong time, 'round seven in the evening when we're doing chores. The farmer ain't got the time to lissen to sech stuff; he's got work to do, and when that's done,

he goes to bed. The only chanct he's got is in the winter when work's slack, and then those market reports don't do him any good 'cause there ain't no crops!"

I was beginning to understand what was meant by "agricultural depression." My acquaintance continued.

"The trouble is, I guess," he closed his eyes as he became philosophical, "that most of us are too old. It's a thing for the *young* people. There ain't no doubt in my mind that when they perfect it, radio's goin' to be a wonderful thing. There's heaps of opportunity in it. There's lots of fortunes that's goin' to be made. There's a chanct, now, for a young man like you——"

I excused myself, rather abruptly I fear, and stood on the platform until we had jerked out of Delanson.

Manly Bellinger, an old friend of mine, met me at the Junction, and I settled back in his Ford delighted to abandon the Schoharie Express and its attendant evils. But while Manly was turning over the engine, I caught a glimpse of Jed Wilkins in the Express Office, checking over a collection of boxes and packages, half of which displayed the labels of some radio company. Well we started off, and I was soon breathing deeply of the fresh valley air. As my spirits rose, I asked Manly for the village scandal, which he gladly furnished *ad infinitum*. But my heart sank again as my chauffeur mentioned a new small-town iniquity, RADIO; and he enthusiastically proclaimed that Schoharie's aristocracy had capitulated to it!

Prompted by the instinct of self-preservation, I directed my chauffeur to raise the dust of the *back* street when running through the town, and under no condition to stop, whether for



"VAN"—A RADIO TRAGEDY

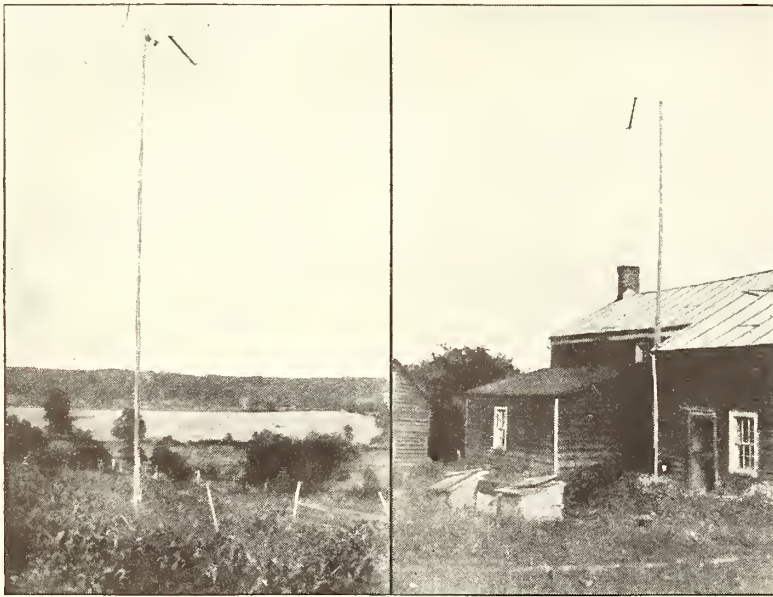

MR. SPADEHOLTZ'S ANTENNA SYSTEM IN THE SCHOHARIE HILLS

blowout or earthquake. Manly was somewhat taken back.

"Well," said he, obviously disappointed, "I kinda told Russ Deyo that I might bring you around to his store before I took you up to the farm—" Manly paused, daunted for the moment by my pallor and the contrasting danger in my eyes. "—yes yes, I know you didn't particularly want me to tell any one that you were coming up this time, but I just figured it out to myself, I did, being that you and Russ are such good friends. . . . And then there's Pert—Pert Badgely at the Newsroom. He's got the agency for the Specific Electric Radios, and he sorta reckoned on seein' you.

He said he had a couple of questions he calculated to ask—"

"That's all very interesting," I broke in ironically, "but it's contrary to orders. You steer clear of Main Street, and when you see Pert and Russ, you just pass it along that I changed my mind and went to Bermuda—no, better yet, to the South Sea Islands!"

**B**UT the farm was Paradise! The weather was lazy and perfect, not a single stretch of wire polluting the blue depths of the sky. The trees, light with the soft verdure of early summer, swung their green laurels unstayed or weighted by

unsightly insulators and spreaders. Not even a telephone or electric-light wire did I see, and I rejoiced in my perfect isolation. I settled down to a quiet existence, and read extensively—*The Dairymen's League News*, *The Schoharie Republican* and *County Democrat*, and the Sears & Roebuck Company catalogue (this last only until I came to the radio department). But such tranquility could not last, and it came to a tragic conclusion two days after my arrival, when Russ Deyo drove up, and burst in on me.

"Well, well, Jack! I sort of thought I'd find you up here, though Manly didn't like to admit it. Well I suppose you came up here to dope out some new radio ideas all by your lonesome!"

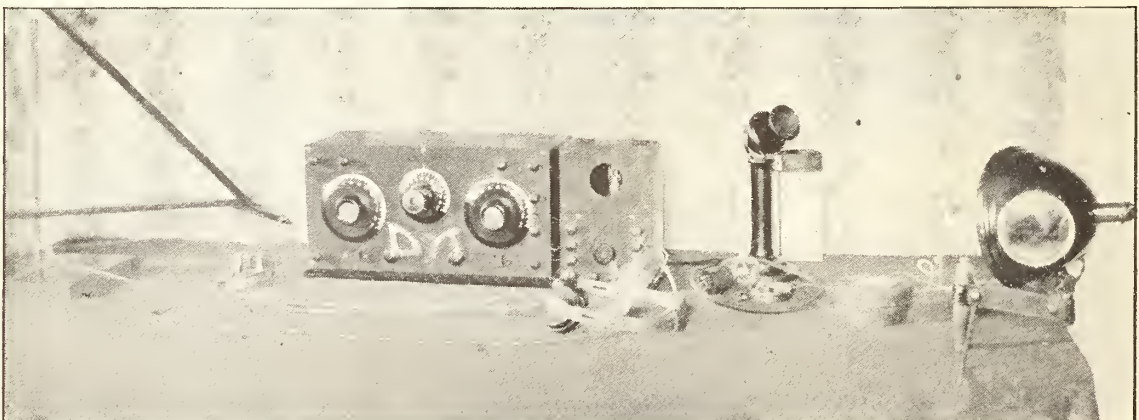

THE NEAT APPARATUS OF MR. SPADEHOLTZ

Both cabinets, the honeycomb coils, loop, and key were all made by him in his amateur workshop



I shook hands with him, though his words had somewhat rubbed my fur the wrong way, and before I could denounce such calumny, Russ elaborated on his delusion.

"I bet you miss your set out here. Nothing to do, no signals to listen to. Well, I think we can make up for that a little bit. I've got a peach of a little set down at the house you can fool around with."

I began to protest, but my friend cut me short.

"Not at all, Jack. It's not the least trouble. I'm only too glad to let you play with the set. To tell you the truth I'm rather proud of that little instrument, and I'd like to have you look 'er over. Come, you're not doing anything this afternoon, why not let me run you to town and show it to you?"

"No, no, Russ," I expostulated (rather feebly), "I don't want—well to tell you the truth, I didn't come out here to——"

"Now, I told you before, Jack, it's not the least bit of trouble, and the Missus'll be glad to see you."

I capitulated; I couldn't offend Russ, so, letting him continue to think that he was doing me a favor, I made up my mind to get it over with as soon as possible. As we drove past the stables, Russ called back to the folks that I would not return to supper, and before I could assure them that I most certainly would be back in one half hour, we were around the corner and out of range. I sat glumly in the car, watching the little dashboard ammeter jump back and forth as we lurched over the hillside road. But the little instrument soon called forth unpleasant memories, so I wrenched my eyes from it, and made a sorry endeavor to be pleasant.

"I suppose WGY is about all you can get around here on a crystal set," I suggested, trying to show an interest in the apparatus which he was taking me to see.

"Yes, that's about all we can get."

"Crystals don't work very well on single-circuit sets, do they?"

"No, I guess not."

I was deciding that Russ didn't know a great deal about receivers, but nevertheless I persevered in talking intelligently about a simple set.

"Do you use a synthetic crystal?" I asked.

"No; no, I never heard of them. What are they?"

Quite discouraged, I said a few thing about

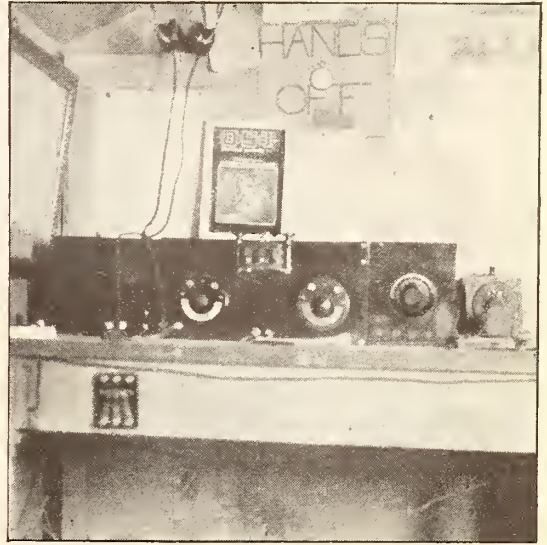

THE LAYOUT OF MARSTON VROOMAN

In Middleburg, N. Y. A set that takes one back to pre-war amateur days

metal sulphides, wondering, for the want of something more cheerful to do, what sort of a mineral he used under the bent safety-pin, which contrivance I was now convinced constituted his "little instrument."

Five minutes later Russ Deyo introduced me to his *five-bulb, two radio, detector, and two audio* set! I was simultaneously introduced to his dog, Van (whom I renamed Pan, as being short for Pandemonium), and I spent the next ten minutes between pretending to enthuse over the apparatus (which really deserved commendation) and warding off the attacks of the mongrel who was sedulously destroying my right trouser leg. I looked first at the glowing bulbs, and then at the dark circles under my friend's eyes, and comprehended. I determined, at least, to save his reason. As Russ left the room for a moment, I called to Van, who had relinquished my ankle in favor of the pedals on the piano, and sicked him on the radio set.

"Get 'em, Van!" I hissed, pointing to the five tubes. "Rats! Eat 'em!"

Van cocked his eye that was airdale (the other was partly fox terrier), and threw one comprehending glance at the apparatus. He yelped pitifully, and flew from the room, his tail between his legs. That dog was the only male member of the Deyo family with sense enough to be scared of the thing. (Poor Van, well might he fear it! He is now dead, and his

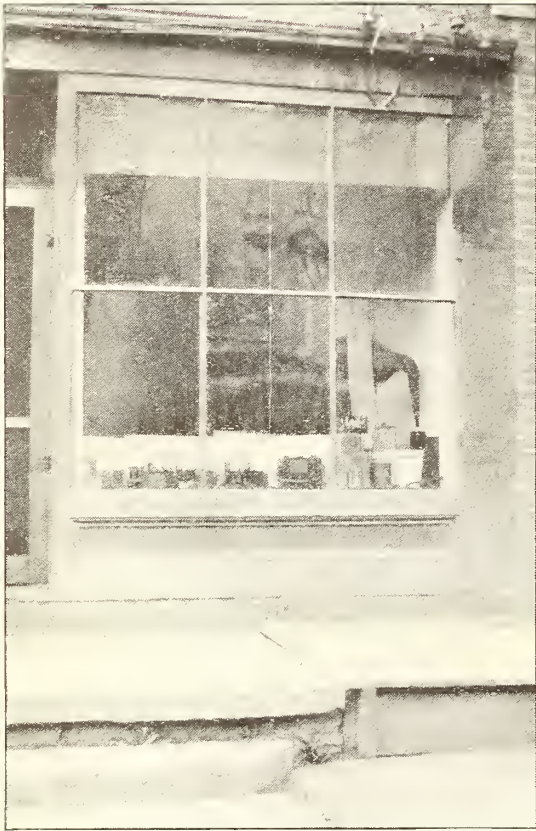

THE UNASSUMING SHOP OF MR. DEYO  
From which he dispenses radio equipment to  
Schoharie, N. Y., and throughout the county

spirit flown at a speed which I hope is greater than 186,000 miles a second. He ran into a moving automobile one night in a precipitate rush to escape from the loud-speaker.)

Russ returned a moment later, his face beaming.

"Come on, Jack, we're off! I've got a treat for you. We're going up to Spadeholtz's farm on the hill. He's got one of the neatest little sets, and he made every bit of it himself on the farm. He's got antenna masts, and——"

"I'm sorry, Russ, but I must get back to the Mackeys'. Supper, you know, and besides——" But my protests were futile.

"Nonsense, you're eating with me. Come on!"

By this time I was prepared to look for something better than a crystal set, and under happier circumstances I should have admired the ingenuity of the lad who built his set on the lonely hillside. A year before, I could have appreciated the antenna and its supports, the clean-cut appearance of the apparatus, the audion sockets, transmitting key, loop, honey-comb coils and omniphone, *all home made!* As

it was, I assimilated these details quite dispassionately, and made not the slightest protest when Russ announced that he was now going to show me another station located somewhere in Middleburg owned by one Marston Vrooman. I was led, unresisting, much after the manner that a criminal is conducted to and from the scenes of his crime.

Young Vrooman's station brightened me a little, for in appearance and layout, it was reminiscent of the old amateur days before the war. But my retrospective thoughts brought the evils of to-day into a more prominent relief, and I soon sank back into my "slough of despond."

I WAS depressed the next day, and in my melancholy, the blue sky seemed hidden behind a network of a thousand antennas. I went to town that evening, hoping to lose myself, mentally and physically, in the motion picture theater. But Russ saw me first.

"Hello there, Jack!" he beamed. "I've been wanting to get up to you all day, but I've been as busy as the deuce. I'm going to take you down to Charlie Holmes's, you remember him. He's got quite a set, and I know you'll be interested in it. I'll get the car——"

"No! No you won't, Russ!" This time I would be firm. "Impossible! I'm going to the show, and nowhere else." But Russ smiled as cheerfully as ever.

"All right, fine!" he assented. "Hattie Meyers has a set there in the theater. It's the same as Charlie Holmes's, in fact he installed it. . . ." and in half swoon I heard only vaguely the details of ". . . Westinghouse . . . two step . . . Western . . . loud-speaker. . . ."

As we left the theater, two tortured hours later, Russ, always painfully enthusiastic, grabbed my arm.

"Now, I'm coming up for you to-morrow night, Jack. The firemen are giving a combined party and radio dance, and I know you'll want to be there. In fact you can operate the set. Well good night, Jack!"

"Good-bye, Russ," I said, "*Adieu!*"

The next morning Manly Bellinger made what reparation he could, and in his Ford, he sneaked me away from Schoharie before the sun was fairly up. I didn't dare brave the train. I had just been reading about the receiving experiments on the Lackawana Railroad and Heaven only knows what atrocities Russ might have committed on the Schoharie Limited.





WD-11's and WD-12's on the aging table. The tubes are kept on this table one hour to increase the possible electron emission and to test for the degree of vacuum

## How Vacuum Tubes are Made

Following the WD-11's and WD-12's Through One of the Plants in Which They are Made

By W. W. RODGERS

Westinghouse Electric and Manufacturing Company

This is the first time that an article has been published in a radio magazine describing and illustrating the important steps in the manufacture of vacuum tubes. Except for minor modifications and a difference in the exhausting process, all vacuum tubes are made in a way much like the dry-cell tubes here described by Mr. Rodgers.—THE EDITOR.

**I**F ONE were asked what single factor has made radio universally popular in America, the answer might not be as difficult as it first seems. For, of the many things introduced into the radio market for the benefit of amateur and fan, the dry-cell vacuum tube stands supreme in the number of radio enthusiasts it has added to the list of those who nightly listen-in. Thousands of new fans were created as soon as the dry-cell tube began to be sold in quantities.

This little tube eliminated a sharp class distinction in the radio world. Before it came there were the crystal detector users and the vacuum-tube users. Crystal detector sets were numerically superior to vacuum-tube sets when

all that could be obtained was the six-volt tube operated from a heavy and expensive storage battery. People who could not afford these items had to be content with crystal detectors, and thus were very limited in their range of radio entertainment.

Then came the dry-cell tube, changing this condition. The purchaser of the one-volt tube could procure his current from a 40-cent dry cell; whereas the storage battery needed for a six-volt tube cost from ten to twenty dollars. There was such a rush on the part of the public to buy, that for a time the manufacturers were swamped. In fact, two great shortages have occurred in the vacuum tube supply since they were first placed on sale.

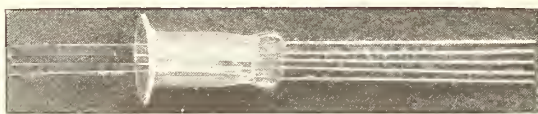

FIG. 1

The short glass tube has a flare on one end and its other end has been melted and pressed down around the five wires, which are imbedded firmly in the glass. Note that there are five wires in the glass press, but only four leads come through the flared opening. The fifth wire is a blind which acts as a support, later, for the plate

These shortages are not likely to occur again as they occurred with a type of tube made by one company, which at the time was the only concern in America capable of producing these tubes in quantities. There are now two companies making such vacuum tubes, and thus with their increased facilities a much larger production is available.

The first commercial dry-cell vacuum tube, the WD-11, is a product of the Research Laboratories of the Westinghouse Electric and Manufacturing Company at East Pittsburgh, Pa. It was here that the need for such a tube was first seen and the research work necessary to the perfection of the finished tube carried on.

Early in radio telephone broadcasting history, after the public had indicated its interest in the concerts and the possibilities of the industry were realized, the need for a vacuum tube which could be operated at low cost was clearly seen. It was apparent to the men who had the problem to solve that the first cost of the tube was not what prevented an almost universal interest in radio, but that it was due to the upkeep, as they say in the automobile world. Storage batteries cost money to buy and to keep charged.

Long before the first order was given the Research Laboratory to start experimenting on the proper material for a low-voltage filament, preliminary work had been started by the research engineers. It had been discovered that a new filament was necessary. This filament must consume a very small amount of current yet have a satisfactory electron emission.

However, in spite of the preliminary experimenting on the tube, it was nearly eight months before the Research Laboratory, which received its order from the Company officials to start developing a tube having the WD-11 characteristics in March, 1921, was able to furnish the perfected tube. The first commercially

practical tube was completed October, 1921. During the eight months intervening a new oxide-coated filament was perfected and the WD-11 type designed.

At first there was some trouble in securing the proper type of worker—one who required no small degree of skill in the various stages of assembly. Girls had been decided upon for a large number of the manufacturing operations, and a few thought that it would require a long period of training to fit them for the work.

While the organization was being perfected the Research Laboratory undertook the construction of 400 tubes. This order came in October, 1921. With an augmented force the 400 tubes were completed in a short time. Then another order for 400 tubes was placed with the Research Laboratory and upon its completion, another and still other orders. The tube became popular at once and the demand for it by the public exceeded expectations.

At the time the tubes were being assembled in the Research Laboratory, a section of the factory in East Pittsburgh was being equipped to build the tubes. The men and girls trained by the research engineers formed the nucleus of the larger force required in the department of the Main Works where the tubes are now assembled. Soon this department was building tubes in daily increasing quantities.

Since the vacuum tube department was given the task, production has so increased that

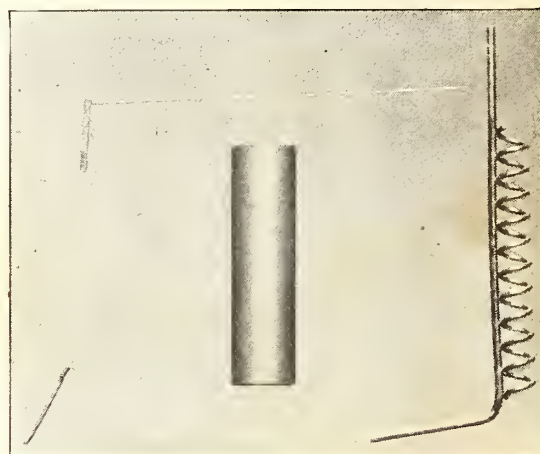

FIG. 2

The filament, plate, and grid of the WD-11 and WD-12 dry-cell tube. Note that the ends of the filament are held by two clips and that there is a support running from the upper clip. These attachments are provided so that the filament may be spot-welded to its support



now the average number of tubes assembled daily is 7,500. This is quite a large quantity when one considers the care necessary in their assembly and the number of tests each tube is required to pass before it is considered ready for the purchaser.

The WD-11 and WD-12 tubes, which are identical except for their bases, despite the fragile character of the materials used and the great care and skill necessary to their proper assembly, are sturdy bits of apparatus, well adapted to withstand fair handling and give efficient service during a long life. Much attention has been given to constructing them so that they might be small yet not at all delicate. This does not mean

that they are dropped on the ground to test the strength of the glass, nor that they will come up smiling after having  $22\frac{1}{2}$  volts connected across their filaments. How many users have burned out their dry-cell tubes because of this error! The filament voltage should not be more than one and one-tenth volts.

There are two main units in these tubes—the outer tube, from which the air is removed, and the assembled inner unit. If this is kept in mind and if it is understood that all assembly is done on the inner unit which is then inserted in the outer tube, sealed in and the outer tube exhausted of air, the various stages of manufacture may be followed very easily.

There are 13 steps or processes through which the parts go before they emerge as the complete vacuum tube. There is a test made after each stage of the assembly and still further tests after the tube is completed. The tests are so severe that a tube after it passes through them is rarely returned from a customer for failure to operate correctly.

The raw materials from which the completed tube is made consists of the glass blank, which is purchased from the glass manufacturer already shaped—this forms the glass walls of the tube; a thin glass stem; a short tube of glass, which is later shaped and which holds



FIG. 3

Mounting the filament—step seven in the assembly. The operator is holding the assembled inner unit in her hand while she spot-welds the top of the filament to its support

the wires in place in the tube; the filament, cut to size and coated at the East Pittsburgh plant; the plate; and the grid. The plates are shaped from a rectangular piece of metal, and the grid wires are wound into the spiral form they take in the completed tube.

All these units can be seen in the photographs of the assembly process.

The first step in the process is the making of the flare. This consists in heating the small tube on one end to soften it and then spinning on the flare.

It will be noted, if one looks closely (Fig. 1) that there are five wires in the press or inner unit of which four run through. The fifth wire is merely a blind inserted to act as a support for the plate. These wires are white at the top but red where they adhere to the glass in making the seal tight. Dumet wire is used for the seal, nickel being welded to it at the top. A copper covering is necessary so that when the press is melted to hold the wires at its top, a gas-tight joint is formed.

The placing of the five wires in the press is the second operation of the assembly. What this resembles with the five wires imbedded in is clearly shown in the photograph.

Next the stems are cut to the proper length so that when the plate, grid, and filament



FIG. 4

The assembled inner unit complete, with grid, plate, and filament mounted. The flare at the end of the glass mount is used for sealing in this assembled inner unit to the glass blank

(Fig. 2) are inserted they will fit in their proper places. This makes the fourth step in the operation.

Step five consists of mounting the plate. This is spot-welded to its support by a girl who has a special machine for the task.

Step six consists in mounting the grid. This is also spot-welded at the top and bottom to its mounting.

The next step is mounting the filament (Fig. 3). This filament, which is a platinum iridium alloy, coated with an oxide of barium and strontium, comes to the girls already cut to the right length, properly tested and with its ends ready for mounting. Mounting the filament is probably the most delicate task in the assembly of the tube.

There is a good reason for using an alloy for the vacuum-tube filament. Ordinary metals are not used because they are not as strong at the temperature to which they are subjected as is the alloy. Making the tube strong enough to stand the wear and tear of daily use was ever a problem before the research department. All sorts of metals were tried. The WD-11 filament has a long life which accounts for the fact that it will give service for a period often ranging between 2,000 and 3,000 hours.

Step seven is completed with the mounting of the filament (Fig. 4). The weld press is completed and is ready to be placed in the glass blank (Fig. 5), which first must be prepared for exhausting.

Step eight in the process is called tubulating the glass blank (Fig. 7). A thin point of flame is blown against the rounded end of the glass blank, so that a tiny hole is melted through. Then the glass tube is welded around this hole. The blank now has a glass tube running

from its end (Fig. 6). This glass tube is attached for the purpose of exhausting the tube. As the other end of the tube is sealed this end remains so that it can be attached to the pumping machines.

The next step, number nine, is termed sealing-in (Fig. 8). When it is finished, the glass weld with its mounted plate, grid and filament and the four wires, running out of its end, is firmly sealed to the glass blank. The flare, first spun on the press, is used to make this joint.

At this point, the tube resembles a completed vacuum tube except that it has no base and has a long glass tube mounted on its top.

When the sealing is completed, the tube is tested for leaks in any part of it. It is also tested for short circuits from filament to grid and from grid to plate.

Step ten—exhausting the air from the tube—is a very important one (Fig. 9). Before arriving at this stage, a getter has been painted on the base of the glass weld. It can be seen as the white dab on the press holding the five wires in place. From 10 to 15 minutes are required to exhaust each tube.

In exhausting the tube, the glass stem at the top is inserted in a piece of rubber tubing which leads directly to the pumps. These are two in number, an oil pump and a mercury-vapor pump.

A covering is pulled down over the tubes. This covering serves as an oven to bake them at a temperature of 400° Centigrade and thus reduce the gas content.

Then the pumps are turned on and the tubes exhausted to a pressure of one-millionth of a millimeter of mercury. This is a much higher point of exhaustion than that given the electric lamp.

As the tube sits in the holder, it is surrounded

FIG. 5  
The glass blank as it is received from the glass factory

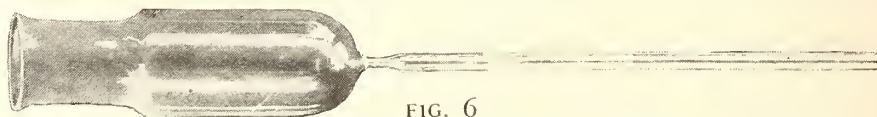

FIG. 6

The glass blank with its stem attached. This stem is used in the process of removing the air from the tube



by a coil of heavy copper wire. The covering is now pulled up and a high-frequency spark is thrown on this surrounding coil to test the tube for cracked glass.

After this, the plate is heated red hot by an oscillating current having a frequency of 1,000,000 cycles—these are generated by two 250-watt tubes similar to those used for transmitting purposes—to remove the gas from the plates and metal supports.

Next in order is the turning off of the plate oscillations and heating the filament to obtain the proper chemical reaction on the filament oxide and thus increase the possible electron emission.

The tip is now sealed off by the machine operator using a gas flame, which he runs around the bottom of the glass tube until it melts off and forms the tip.

Finally the tube, properly exhausted is removed from the machine, complete now except for the base (Fig. 10).

The tube now passes through several stages of inspection before the bases are cemented on. During this inspection, the tube is carefully looked over for appearance and poor tips, and for degree of vacuum. Opposite the inspectors who take the tube at this stage there is a box into which the rejected tubes are tossed and smashed to fine bits.

Step number eleven is cementing the base to the tube. Just before "basing," a small glass stem is slipped over each of the four leads to prevent any shorts at this point. The base is filled with a cement, an operator draws the four wires through the stems in the bottom of it, and the tube with its base attached is placed in a machine which bakes the base on firmly. Included in the basing operation is the soldering of the bottom of the tips on the base and rounding off the ends of the stems. An operator dips the stems in a solder pot so that the wires running through the stems are soldered firmly

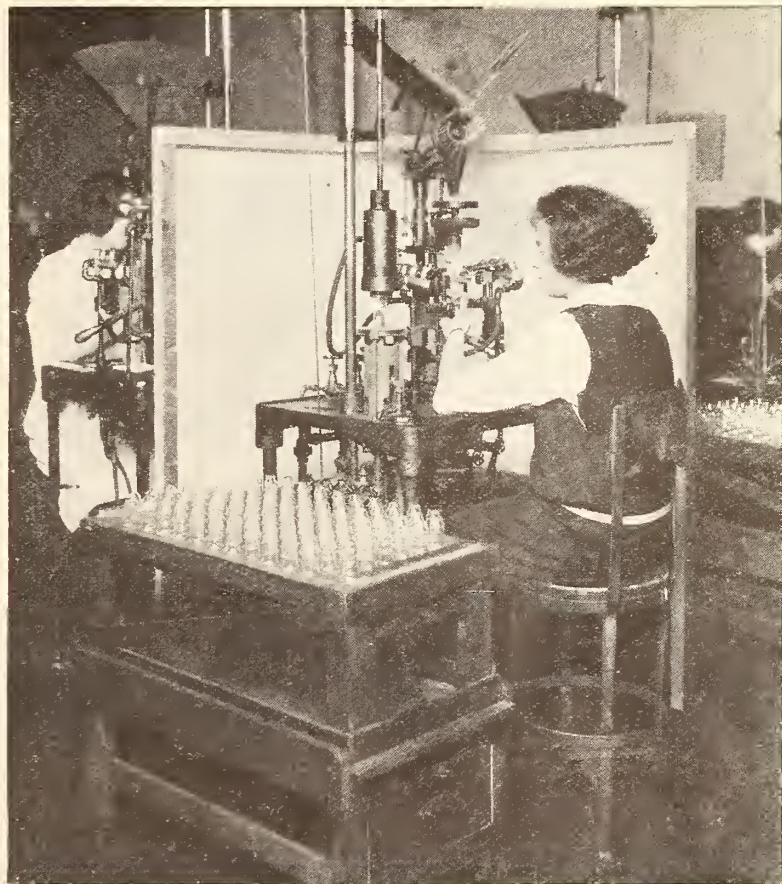

FIG. 7

Tubulating the blank. A tiny hole is melted in the rounded end of the glass blank and around this hole is sealed a glass stem

in place. To make a neat job, the stems are next placed in a machine so that they are rounded off properly. Just look at the tips on the base of your vacuum tube to understand this operation.

Thus when the tube reaches this stage it resembles the one used in the receiving set. But it still has some tests and processes to go through before it can be called completed.

The next step is a test, and while it is given no number in the order of assembly, it is important. This test is termed lighting out the tube (Fig. 11). An operator places the tube in a base connected to three electric lamps; one red, one blue, and one white. The red lamp is in series with the grid, the blue lamp is in series with the plate and the white lamp is in series with the filament. If, when the tube is placed in this base, one of the lamps glows, it is discarded, for it plainly can be seen that the wires are short-circuited and the tube is unfit for use.





FIG. 8

In this process, the assembled inner unit is sealed by means of its flare to the bottom of the glass blank

Those of the tubes which pass this test go on to the next stage. This is a test and a process combined for developing more efficiency in the tube. It is step twelve, otherwise known as the aging process. In it the tubes are placed upright, several hundred at a time, on a table, with their leads connected to circuits which are slightly stronger in voltage than the tube is subjected to in normal use (photo p. 397). The tubes are kept on this table one hour to see if any faults develop and to obtain the maximum electron emission from the filament. During this aging test, sometimes the degree of vacuum is found to be insufficient. This condition can be determined by a measurement of the nega-

tive grid current. During the aging process, the getter absorbs such gases as might remain in the tube.

After leaving the aging table, the tubes are stored for three days. This is time enough to determine whether there are any air leaks. After this final storage, they are again tested for all circuits, filament emission, degree of vacuum and appearance and are ready for shipping.

The final stage is the packing. Those who have purchased the WD-11 know how carefully it is packed in its cardboard box with many layers of packing material wrapped around it.

The process of assembling these tubes is one that is long and tedious, calling for the utmost skill on the part of the various operators. In assembling the

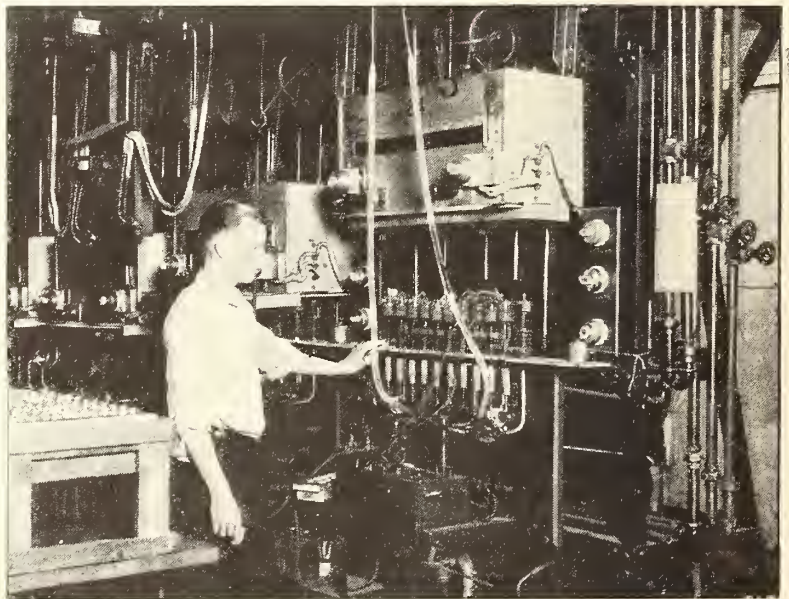

FIG. 9

Exhausting the tube—step ten. Ten tubes are exhausted simultaneously in this machine. Each one is surrounded by a coil, described in the article, and its glass stem is attached to a rubber tube (seen underneath the shelf) which leads to the pumps. The white box-like affair just above the row of tubes is the oven. It is pulled down over the tubes to bake them as a part of the exhausting process



plate, grid and filament, girls do the task. They do, also, most of the preliminary tests. Men operate the exhausting machines and do the final testing.

A visit to the vacuum-tube department at East Pittsburgh is a revelation of the efficiency of the workers. The recruits are trained by skilled operators a number of weeks before they are placed at the task of doing the actual assembling. Some difficulty is experienced in obtaining girls who are dexterous enough to do the work properly. The employment department thinks that if one girl out of ten or fifteen sent to it is found satisfactory, it is doing well. All these things must be considered in the assembling process. The skill of the worker is largely responsible for the efficiency of the tube.

Dry-cell tubes have been brought to a high point of efficiency, and experiments are constantly being carried on to develop this efficiency further. The point now has been reached where it costs much less to operate the filament of a vacuum tube than it does to light the electric lamp above the head of the radio enthusiast operating his receiver.

Each tube is a monument to masterful research, inventive genius, the wizardry of modern machinery and a perfect organization of workers and officials.

It is certain that further experiments now going on will reduce this operating cost and still further lengthen the life of the dry cell. The Research Laboratory which first developed the tube is constantly working on various forms of low-voltage tubes. These stories, however, must wait until the tubes are perfected.

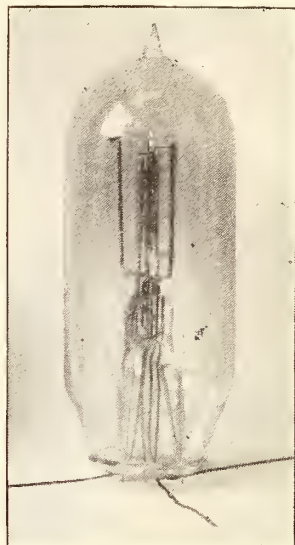
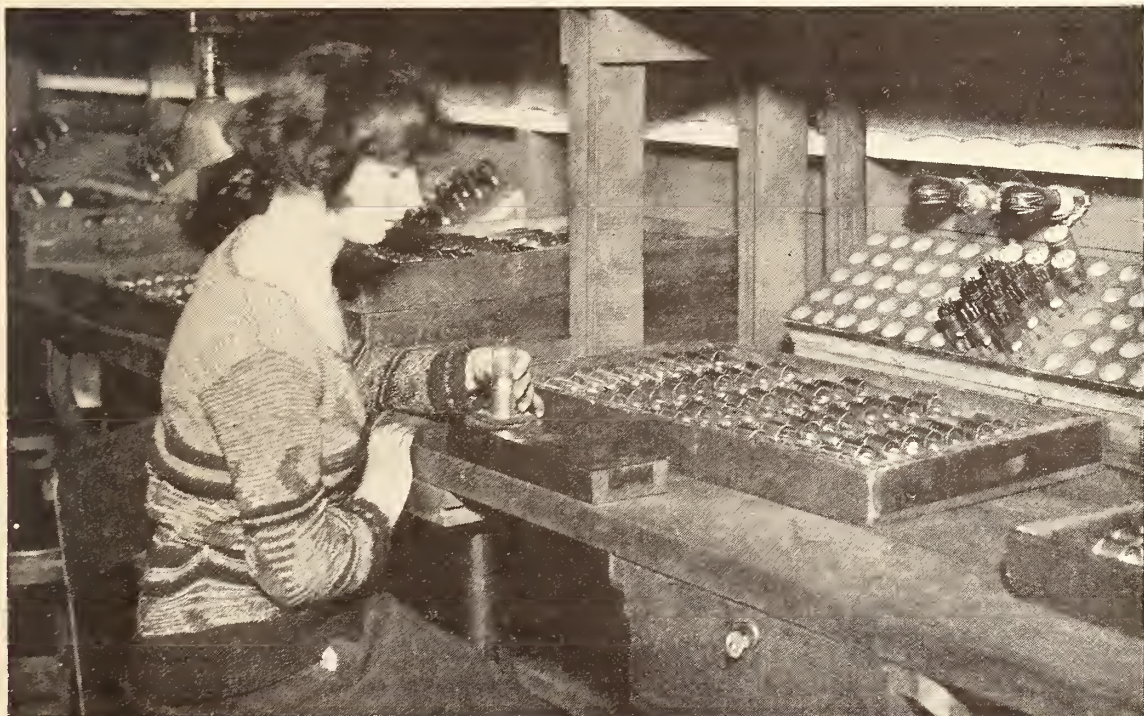

FIG. 10  
After the tube has been exhausted and the glass stem sealed off, it resembles the completed tube except that it has no base

FIG. 11

"Lighting out." The tube is placed in a holder leading to the three lights in series with the grid, plate, and filament. If one of the lamps lights when a tube is placed in the holder, the operator knows that the tube has developed a short circuit



# Some Notes on Tuned Circuits

Inductance and Capacity—The Two Factors that Affect the Wavelength of Any Circuit

By M. B. SLEEPER

**A**FTER all the years that we have had radio experimenters, there are still inquiries pouring in concerning the wavelength of a coil or a variometer. Strangely enough, in spite of the great importance of tuned circuits, comparatively little has been written to give the sort of detailed explanation of them that have been given for vacuum tubes and various other phases of radio equipment and circuits.

In order to have the right idea about wavelength and tuned circuits you must first realize that a coil has no inherent wavelength other than its natural period—a useless factor in tuning. It would be just as incorrect to talk about the wavelength of a variable condenser as of a coil or variometer, for wavelength depends upon inductance *and* capacity. You would not speak of the area of a length. You think of area as depending upon length and width. In the same way wavelength is determined by the amount of inductance of a coil and the capacity of a condenser.

Perhaps one of the reasons for this confusion is that the nature of the capacity in a tuned circuit is not always apparent. Consider the circuit in Fig. 1, that of an ordinary loose-coupled set. It is divided into a primary or antenna circuit and a secondary circuit. You might think off-hand that there is only the inductance of the coil in the antenna circuit.

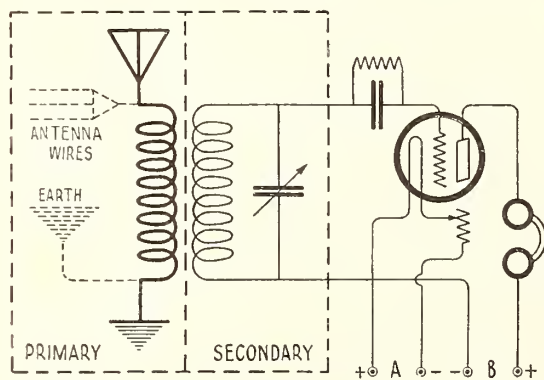

FIG. 1

The antenna-to-ground circuit in any receiver provides capacity as well as inductance

Actually, the antenna provides the capacity, because, just as you have in the secondary circuit a coil connected to the two sets of plates of a condenser, so in the primary you have the upper end of the coil going to wires strung over the ground, and at the other end a lead to the earth. The antenna wires and the ground serve as condenser plates and the air separating them as the dielectric. Therefore, the wavelength of the primary circuit is not determined merely by the inductance of the coil, but by that inductance and also the capacity of the antenna-ground condenser.

If, then, you use the primary coil of an ordinary variocoupler in the antenna circuit and your antenna is very small, perhaps a single 50-foot wire, the antenna-ground capacity will be very small and the wavelength correspondingly short. When you increase the antenna to one of four wires, each 100 ft. long, the capacity will be much increased, and, as a result, the wavelength in the primary circuit will be greater than before.

Frequently experimenters complain that they cannot tune down to the 200-meter stations. Investigation usually shows either that the antenna is too large or the minimum tap on the coil gives an inductance so great that the wavelength at the lowest is above 200 meters.

The antenna tuning is not so important as the tuning of the secondary circuit, for the reason that the resistance of the antenna, the ground lead-in, and the ground connection is very high, and consequently tuning is not very sharp in the antenna circuit.

New types of receiving equipment for wavelengths from 150 to 1000 meters are often made with untuned primaries. This is entirely practical, unless the antenna is so large that its capacity and the inductance of the lead-in and ground connection is sufficient to give a wavelength, regardless of the inductance of the tuning coil, very much above the minimum wavelength to be received. A loose coupler, or, as it is more often called, a fixed coupler, with a non-adjustable primary winding relies largely upon shock excitation of the secondary



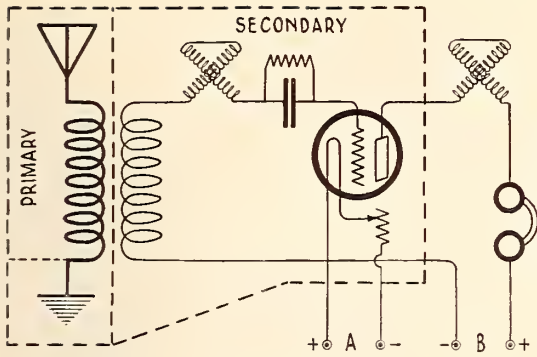

FIG. 2

Capacity in the secondary circuit is supplied by the elements of the tube and by the coils themselves

rather than on tuning the primary to the exact wavelength of the incoming signals.

One method of reducing the wavelength in the antenna circuit is to connect a variable or fixed condenser in series with the lead from the antenna to the coil, or from the coil to the ground. This reduces the wavelength because the total capacity of two condensers in series, in this case the antenna-ground condenser and the condenser in the set decreases the total capacity of the circuit. On the other hand, the wavelength can be increased by shunting a condenser around the coil, for it is then in parallel with the antenna-ground capacity. Two condensers in parallel give a total capacity equal to the sum of the two.

The secondary circuit is quite simple in an outfit such as that shown in Fig. 1. The wavelength is determined simply by the inductance of the coil and the capacity of the condenser. Sometimes a fixed inductance is employed with a variable condenser; or the coil is tapped so that the number of turns in the circuit, and correspondingly the inductance, can be varied.

The absurdity of saying that the coil is a 300-meter inductance is evident from the fact that the wavelength of the circuit varies according to the adjustment of the condenser. Tables are available for determining the wavelength of any circuit according to the inductance of the coil and the particular setting of the condenser. If honeycomb coils are used, the wavelength can be found from tables or charts supplied by the manufacturers.

It should be noted that, in any circuit, the wavelength does not change in direct proportion to the inductance or capacity, but according to the square root of either factor. In

other words, if the condenser capacity is increased four times, the wavelength is only doubled. A very simple formula gives the exact wavelength:  $\lambda = 59.6 \sqrt{LC}$ , where  $\lambda$  is the wavelength in meters,  $L$  is the inductance in centimeters, and  $C$  the capacity in microfarads. Remember that one million centimeters is equal to one millihenry of inductance.

Fig. 2 is rather puzzling. It shows the circuit of the familiar two-variometer receiving set. At first, you might say that there is no capacity in the secondary circuit, but only the inductance of the coil in the variocoupler and the inductance of the grid variometer. There is capacity, however, for the grid of the tube acts as one plate of a very small condenser and the filament and plate of the tube serve as the other plate, not to mention the distributed capacity found between adjacent turns of the coils themselves. For that reason a much higher inductance is required than would be needed if the circuits were tuned by a variable condenser.

Often the question is asked whether or not the plate circuit is tuned also to the wavelength of the incoming signals. It is not necessary to do this, for the plate variometer gives only an approximate adjustment.

Some manufacturers have attempted to rate their variometers for wavelength, and in that way have encouraged experimenters to think of the wavelength ranges of variometers. This is a misleading practice, for the wavelength is considerably altered by the size of the secondaries used in different types of variocouplers. Moreover the capacity of vacuum tubes varies considerably, the capacity of the UV-199 being very

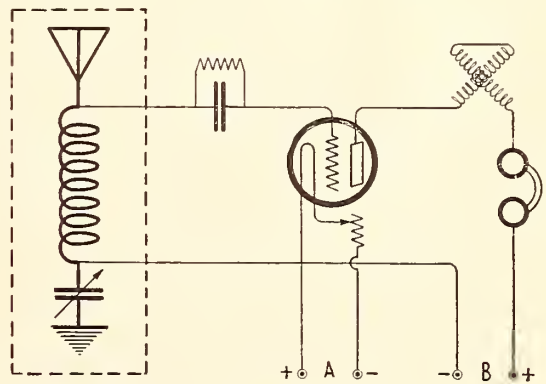

FIG. 3

This single-circuit hook-up depends upon the antenna capacity, inductance of the coil, and capacity of the tuning condenser for its wavelength

low and of the UV-201-A or VT-1 comparatively high. However, a manufacturer can say that his variometer, when used with a particular type of variocoupler and vacuum tube, tunes over a certain wavelength range.

If the antenna capacity is specified, the primary circuit can also be rated for wavelength. That, however, is not a very useful rating because antenna capacities vary greatly: they are not determined merely by the dimensions of the wires. Trees, buildings and metal roofs or large chimneys increase or decrease the capacity. An antenna erected over dry earth does not have the same capacity as one stretched over moist earth, for example.

A single-circuit receiver, such as the one shown in Fig. 3, depends upon the antenna capacity, the inductance of the coil, and the capacity of the tuning condenser, for its wavelength. Since all the tuning is done in the antenna circuit, which, as explained before, has too high a resistance to give sharp tuning, more or less trouble from interference is often

experienced. You will find, too, that the setting of the plate coupling coil or plate variometer will affect the wavelength, for it introduces another value, that of mutual inductance between the two coils, altering the effective inductance in the circuit. Thus, altering the antenna circuit requires a new setting of the plate variometer, or vice versa until a suitable balance is reached.

If you want to design your equipment accurately, you must measure the antenna capacity. This, however, is not at all necessary in installing or operating a bought receiver, for most of that work has been done for you. The method is simple, and details of the process can be found in a number of radio books. You will need to find out as much as you can about the constants of your coils and condensers so that you can determine the wavelength range with some degree of accuracy. In any case, do not go by wavelength ratings of coils, vario-couplers, or variometers, and above all do not learn to think of inductance in terms of wavelength.

## A Little Foresight and a Big Success

How a Knowledge of Radio, Combined with Good Business Principles, Enabled A. J. Haynes, of the Haynes-Griffin Radio Service, Inc. to Increase His Business a Thousandfold and Give Customers Better Values and Service

By ALFRED M. CADDELL

**W**HEN a man starts in business with a very small capital and is obliged to seek larger store-space twice within a year, and his assets increase a thousandfold during the same period; and especially when he makes his money on your money—you are interested in him. You want to learn some of the things he knows about the commercial end of radio, something about his business methods and why he has succeeded when countless others, who jumped into the business with both feet, have failed.

An uphill story, or a story that starts from scratch, is generally a good one. It is likely to be a story of faith, determination, and a combination of knowledge and good will toward the business itself. Besides, somewhere in the story, may lie the so-called "secret" of success which others may perceive—and apply.

Artemas J. Haynes has long been in the radio

business, either as an amateur purchasing equipment, an engineer developing new apparatus or, as at present, a business man who brings together the sources of supply and the customer demand. He became interested in radio while a student in preparatory school back in 1910. Like a lot of amateurs, he commenced with a coherer—with which he received very little. His first successful receiving set was an indoor aerial, crystal detector and a pair of 75-ohm phones through which he could hear the local high-power spark stations and occasionally a ship.

He wasn't very different from the average radio amateur of those days and now—every odd moment out of school and college found him building and experimenting with radio apparatus. He had sets and fragments of sets, mounted high on a table and strung around his room—batteries, switches, odd parts, and wire. He went through the regular



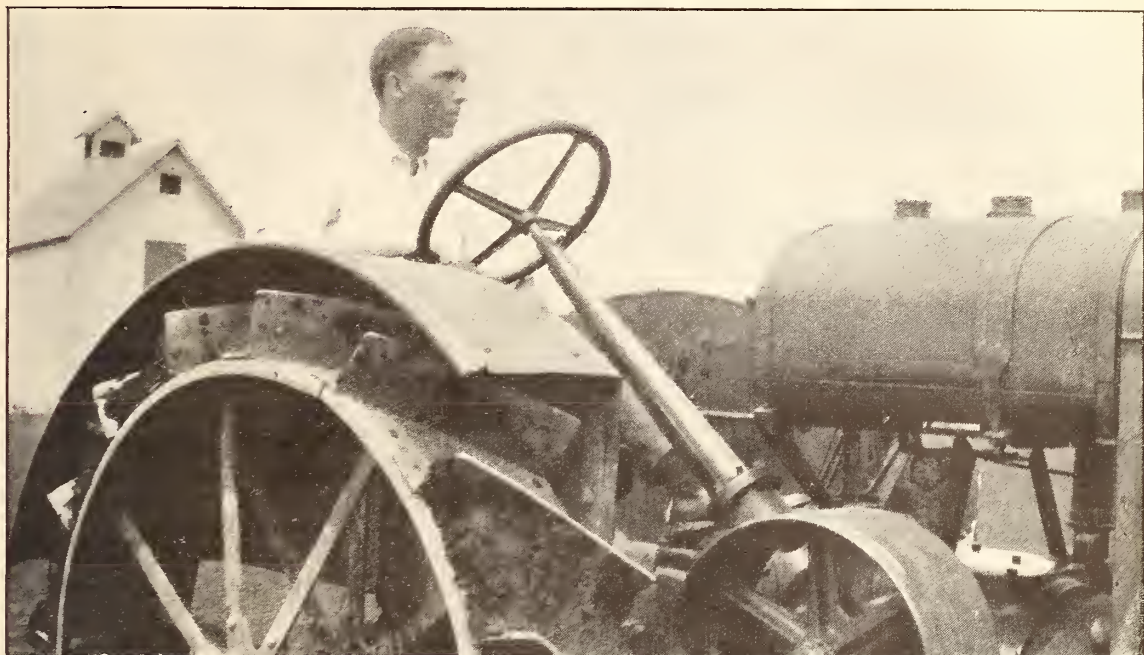

MR. HAYNES, LIKE PRESIDENT HARDING, DRIVES A TRACTOR NOW AND THEN

run of coherers, magnetic, crystal, and electrolytic detectors, tuning coils, loose couplers, and finally ended up with the De Forest Audion, a little round bulb that screwed into a miniature socket, with a small square plate and grid and two carbon filaments—a wonderfully big feature in those days.

“We were all a bit skeptical of that little bulb at first,” says Mr. Haynes. “The promises made for it sounded too good to be true and it wasn’t until after much hesitancy that I finally purchased one and compared it with my prize galena crystal that I realized with a heartfelt sigh that my interminable search for the most sensitive spot on the most sensitive crystal was over.”

When the United States entered the World War in 1917, Mr. Haynes was a student at Yale University. Immediately after the declaration of war he enlisted in the Naval Reserve, and was among the first to attend the Brooklyn Navy Yard Radio School. Things were moving fast in those days, and new orders went flying about, so he quickly found himself assigned as radio operator to the U. S. *Shubrick*, a hastily converted coal-burning destroyer that was pressed into service for patrol and convoy work. Then he went to the naval radio station at New Haven, after which he was suddenly transferred as radio instructor to

Yale University, where he taught many of the boys their first principles of radio.

So much for his pre-business days, which had proved to be a wonderful combination of learning and teaching, resulting in a solid foundation in radio. Now came employment with the De Forest Radio Company as engineer, a year or more in the laboratory and then a position placing him in charge of foreign sales. But in the early part of 1920, when radio as a means of livelihood seemed uncertain, he took a look into the retail music field. Not for long, however. Indeed, he was permitted only a passing glance, for the dawn of radio broadcasting appeared on horizon in 1920-21.

“I think most of us who had followed the business,” said Mr. Haynes, “realized that sooner or later radio broadcasting was bound to become a big thing, and notwithstanding the long, almost impatient wait, it really came much quicker than I expected. As it was, the suddenness of its coming found me in the woods of Maine, but I returned to New York as soon as I could. During the winter of 1920-21 I operated the De Forest experimental station at Highbridge (2XG) which was used primarily for test and demonstration work between Highbridge and 2XX, our other experimental station, operated by Robert F. Gowan of honeycomb coil fame, located at his home in

Ossining. I spent many evenings at old 2XG testing with amateur stations and playing phonograph records to entertain listeners in and around New York. In fact, we staged a good many dances this way in the homes of radio amateurs who were equipped with loud speakers.

"And then the big broadcasting storm broke over the land. Previously, the interest in radio had been comparable to the few drops of rain that announce a cloudburst. Hundreds of wild schemes followed in the aftermath. It was the beginning of the Radio Age. Dealers who had no previous experience with radio or electrical equipment began selling radio apparatus like so many nuts and bolts. Factories soon lagged far behind in filling their orders, a fact which led dealers to duplicate their requirements with many jobbers and manufacturing concerns. But after the first heat of the race, the public called a halt and began analyzing the situation. They became wary of radio sets sold over the books-and-stationery counters, and at the drug store. They began to discriminate between the cheaply built apparatus and that which was more reliable. Meanwhile, manufactures had been led to increase their production, but they had hardly begun turning out the rush equipment when the buying demand fell off. The lure of 'money in radio' soon showed its face—inexperienced dealers who had placed large orders for cheap apparatus found themselves loaded with stock which suddenly had lost half its retail value. Exit from the radio business seemed to many to be the only way out of such an unprecedented situation.

"Fortunately, I had seen a lot of discouragement in trying to get radio broadcasting started, and this operated to make me proceed most cautiously. Would the present flurry last? I saw permanence in radio, but at a distance. As the public now knows, the radio business was encumbered by men with no knowledge foundation whatever, who like get-rich-quick promoters were riding on the back of free publicity. How to avoid the pitfalls that were bound to react from such a situation? How to get into the retail business and make progress at the same time? How to make it known that I had the technical experience, that I knew radio goods, that I had a desire to fit the customer's pocketbook and

needs together, that I aimed to be in the business to stay and was more than willing to cooperate with customers to see that they got the very best out of their outfits to which they were entitled?

"Skimming the cream off milk and expecting that milk to retain its full value presented an altogether incompatible viewpoint. There was only one way to go into a permanent retail radio business and that was to take counsel with customers, talk frankly to them, tell them that you aimed to stay and grow in the business and offer to be of assistance then and thereafter. Reconciling the situation as best I could, I borrowed a little money and opened up a small store known as the Haynes Radio Shop on Lexington Avenue, New York, in the spring of 1922.

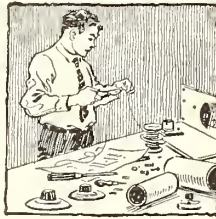

"At first, I barely paid the rent on the place out of the income of the business. But gradually I began to get more customers—young lads who were anxious to have sets installed in their homes. I hired one man, then two, and the little business began to look up. At times the gross receipts amounted to less than \$100 a day, which barely allowed me to make both ends meet. Then it commenced a steady upward climb as the summer slump of 1922 began to draw toward its end. Private installations now became more in demand, one job attracting another. When Johnny Smith or Bobby Jones got in trouble, if I couldn't explain it away when he called at the shop, with a perplexed look on his face, I went over to his place, diagnosed the ailment and set his apparatus in order. After that, it very seldom got out of order, for he was getting accustomed to it and manipulated it only in the way he should.

"During this baby growth of the business I advertised very little, for the simple reason that I had no available funds. But had I had extra money at the time I hardly think I would have plunged into the business any heavier just then. Liquidation, elimination, controversy over the permanence of radio, and confusion were in the air. But at various turns radio broadcasting gave healthy signs of surmounting its troubles. The curve on the chart that I kept and an auditing of my accounts left no doubt about this.

"During radio's inevitable slump in the summer of 1922, I was one of the organizers of the first Radio Dealers' Association of New



York, and served as Vice-President as long as that organization lasted. Mr. Griffin, now my partner in the firm of Haynes-Griffin Radio Service, Inc., was President. Personally, I consider the greatest benefit derived from that association was the bringing of Mr. Griffin and myself together. Mr. Griffin's whole training and experience over a period of more than six years had been in advertising and merchandising with one of the leading advertising organizations in the country. He brought to the organization a breadth of vision and experience which most retail merchants acquire only after years of hard work and hard knocks. This, supported by my own training in the technical side of radio, gave the new organization a combination of experience seldom found in any business conducted solely by one man whose training and inclination generally lies along one particular line.

"Mr. Griffin had been in the radio retail business in rather a small way by himself. But each of us realized that we had progressed as far as we could by ourselves, for in order for either one of us to take care of any more business it meant increased organization. Besides, our individual locations just then were not ideal for expansion—we felt it necessary to locate in a more transient section of the city which offered greater contact with the radio public."

The results of that merger speak for themselves. The two young business men, as partners, began to forge ahead very rapidly. Locating midway between Times Square and the Grand Central Terminal, New York, a more strategic spot for transient accommodation could not be had. It was the one thing needed to assure their success. Shortly after the partnership was effected, the opportunity came to purchase the Lexington Radio & Electric Company, and not only the stock and good-will of that company was taken over but the entire personnel as well. This, therefore, made the Haynes-Griffin Radio Service, Inc. a combination of three of the oldest and best known radio stores in New York City, and the many regular customers which the additional store immediately brought to the combination helped toward the great expansion which has since taken place.

But before this article appears in print, Mr. Haynes and his associates will have given even more tangible evidence of the success which

has followed in the wake of their business methods and ideals. For during July they opened the largest radio store in New York City, which probably also means the largest in the world. Space and facilities are more than tripled in the new store. More than 4,000 square feet are devoted to the sale of radio apparatus alone. In this store are incorporated several new ideas in the merchandising of radio. On the ground floor where parts and accessories are carried there are in effect, three radio stores in one. For the stock of the store is duplicated in three different locations so that customers may be served efficiently and quickly without either salesmen or customers being obliged to move about from counter to counter in order to secure everything that may be desired. On the second

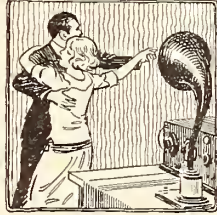

floor there are several small sound-proof demonstration booths similar to those in phonograph shops, where practically every make of proven, well-known radio receiver is on display; while in the basement will be located a repair and service department which, from an adjunct of the radio retail business, has grown to be a department of the first importance.

Many stories of how service and attention resulted in further business abound about the shop. A short time ago a man from Connecticut came into the store to buy an insulator for a receiving antenna. He had been sent in by his employer who thought what he wanted was a very large insulator. However, he was assured that a midget insulator costing twenty-five cents would do as well, and reassured that if it proved unsatisfactory to his employer the twenty-five cents would be refunded and a larger insulator substituted in its place. Furthermore, the salesman obtained the employer's name and saw to it that a letter was written to him that night, explaining to the employer why his man had been persuaded to take the midget insulator. The result of this attention to such a small purchase is almost unbelievable—since then the employer, although he has never been inside the store and is not personally acquainted with the organization has bought more than \$3,000 worth of radio merchandise.

Another instance was that of a young office man in Brooklyn who bought a "Haynes Circuit" receiving set, the development of Mr.

Haynes. He knew little or nothing about the radio art, and was obliged to come into the store on several occasions to get pointers. As a result of the attention given him, he has been instrumental in selling thirty-six sets to fellow office workers and officials in the company where he was employed. All of them were "Haynes Circuits."

A case of a somewhat different type may also be cited. A woman came into the shop, saying that a friend was going to sing that evening at one of the broadcasting stations, and she had been given to understand that if she came to the shop she could hear her sing. Just how, she knew not, but that's what she had been told. Would they be open that evening? Ordinarily they would not, yet this time most assuredly they would. More than that, they invited the woman to ask all her friends—the shop would be a regular receiving station that evening. Eight women came, and listened throughout the whole performance, and eight women had the mysterious something explained to them—that is, explained so that they felt confident they could hear the same kind of music in their own homes. And so eight more enthusiasts, soon to become customers, were introduced into the radio fold that evening.

"I consider that I sell good-will and service more than radio equipment," says Mr. Haynes. "And I think you will find this to be the case with every successful dealer in the radio field. Radio is such a large proposition and so entirely new to most people—a scientific thing made popular—that real merchandising consists of individual education. In the beginning, both dealer and customer were like two strangers who spoke a strange tongue in a strange land. They understood each other very little. Unlike the clothing business, for example, which is as old as man himself, radio burst upon the world as a brand new creation. Customers knew so little about it that they wonderingly asked: 'How much do you charge for an ohm?' and things like that. You couldn't laugh at them—you simply had to explain what an ohm was.

"It was due to this prevailing lack of knowledge that many customers were victimized by unscrupulous dealers who probably didn't know much more themselves but who sold them anything in order to get their money. But it

was also due to this lack of knowledge that we owe our success. It was a wonderful chance to gain a customer's confidence. Each customer, of course, presented an individual problem, but we have yet to meet the problem in the customer line that we have not been able to solve. The sales we have lost by being—as some might consider it—too frank in our advice, have been more than made up in almost every case by the confidence and ultimate business we have enjoyed from those same customers. So much has been written about the 'straight and narrow' way of doing business that I am afraid the eye slides right over it without ever seeing—at least not focussing attention on it sufficiently long. But of this I am sure: that the radio retail dealer who sells service and attention first and equipment afterward will have a larger credit balance at the end of the year than the dealer who sells equipment only."

The speaker led the way to the rear of his shop, opened a locker door, picked out his tennis racket, and prepared to "call it a day." Tennis is one of his standby recreations, and one can see the effects of it in his eye and step. Next comes swimming, and sport with the rod and gun. As is evidenced by the healthy state of equilibrium in which he keeps himself, he knows how to mix pleasure with business and not keep himself too near the saturation point. Besides, his wife won't let him become over-concerned with his hobby, even though it is the radio business.

Like many others in the commercial field who have kept their ears close to the ground and their eyes on the progress of radio, both Mr. Haynes and Mr. Griffin maintain that the possibilities of the art, especially in the way of a quickening of intelligence in all classes of people, are only beginning to be realized. The biggest thing, of course, is the proper control of broadcasting. As one who has seen the broadcasting art develop from "Station 2XG, calling—1, 2, 3, 4; Station 2XG calling—1, 2, 3, 4" to the present high state of efficiency, Mr. Haynes has confidence that broadcasting will develop equally as much again; that the day will come when broadcasting will be subsidized by the government for the unlimited use of everybody—not a local or state affair, but national, as an investment in education, recreation, and good citizenship.

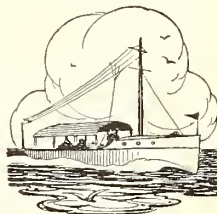



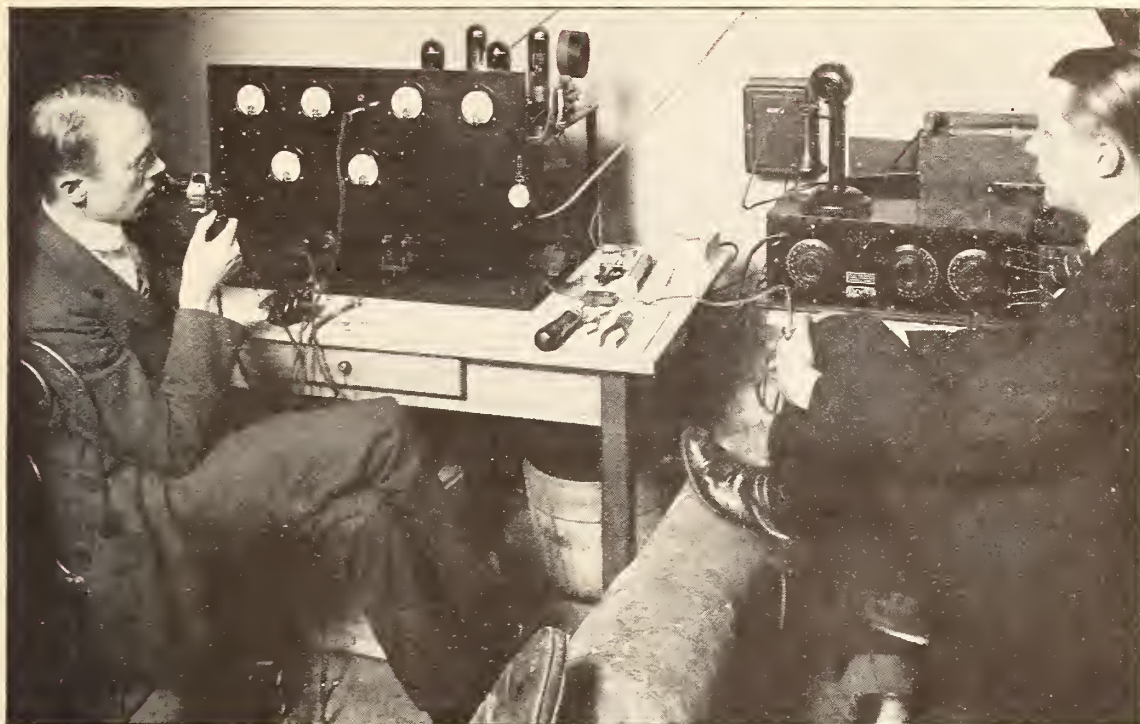

ELLIOTT JENKINS (LEFT) AND THORNE DONNELLEY (RIGHT) TESTING THEIR WRIGLEY TOWER OUTFIT

## Highlights in the History of WDAP

The Chicago Broadcasting Station that Plays Dance Music for Half a Continent

By J. ELLIOTT JENKINS

I CANNOT make up my mind whether this brief history of WDAP, which I am writing at the request of the Editor of RADIO BROADCAST, will be a confession or a biography. However, it should be somewhat amusing, especially to those familiar with broadcasting stations. It certainly is to me.

Thorne Donnelley and I, though we had never worked together before, had been perfectly good hams in the days of Morse and carborundum, when you used part of your father's automobile for your transmitter, and your initials were your call. My early training in the art of making the cook's favorite rolling pin into a tuning inductance came from Paul Godley, then an operator on the Great Lakes. But in 1921, when the Local Westinghouse station first opened up with the Chicago Opera, the trouble began. Donnelley came up to my house one evening to consider a Morehead

tube hooked to a loose coupler tuner. Strains of Aida were faintly audible. This was too much. The following week, I was summoned to his house, where he had collected most of the receiving apparatus in Chicago. It covered the floor and the grand piano, and a certain amount of it would function. A few days later came a hurry call on the arrival of a 20-watt Paragon transmitter. This gave room for a lot of thought.

A few days later, riding past the Wrigley Tower on Michigan Avenue, I said I thought it would make a good place for an experimental laboratory. About a week later, Donnelley came bursting into my own laboratory on Van Buren Street, followed by three men, two boys, and several dozen boxes. I said, "What's this?" and he replied, "Our broadcasting station for the Wrigley Building. I'm going over there now and string the antenna while

you put this stuff together." He shoved some papers at me, original art drawings by Charlie Logwood, then in Chicago, of a 100-watt, grid-modulated oscillator, and I went at it.

In about a week the thing was up, perched in the penthouse among huge water tanks and steel pipes. It led into a sort of cage antenna which hung at an angle to the tower. It radiated four amperes and sounded like nothing the air had ever heard before. We worked it as 9CT for a while, and then our broadcasting license arrived. This necessitated a studio. A dear friend of ours was experimenting with the advertising business on the floor below, so we appropriated the front half of the office and moved in a piano and a few yards of drapery. We overcame the microphone problem by

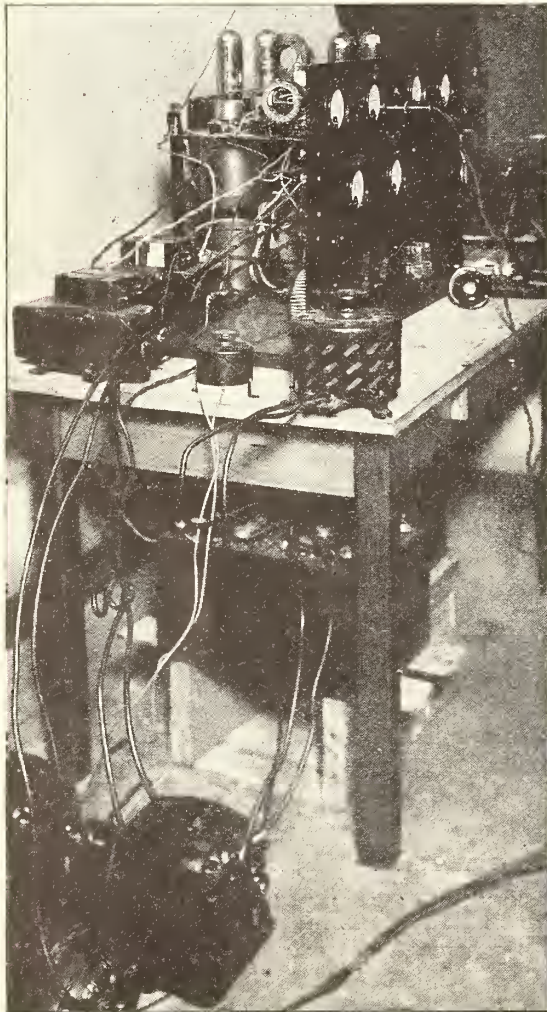

THE STATION IN THE WRIGLEY TOWER  
Showing generators, inductances, "hay wire," etc.

packing a four-button carbon affair into a fibre waste basket and hanging it on a pale blue parrot-cage support. I shall never forget the general effect. On top of the piano sat a loud speaker, connected to a hand microphone in the operating room. When the operator—it required just one to run the transmitter and the concert—would announce the station and the next number, it would be fairly audible to those in the studio. Then he would turn and bellow—"All right, *shoot!*" and the temperamental talent below would recover as rapidly as possible and do its best at the waste basket. It was a great way to run a station, and I wish we could return to it.

"WDAP, located on the Wrigley Building, Chicago, Illinois (it's a wonder we left off the U. S. A.), ground out her closing quotations and her three concerts a week all through the winter and up to July, 1922, steadily growing worse. It is a curious thing, that process of natural decay which a station, put up by the inexperienced, always undergoes. It just gets worse, despite your increasing knowledge and your violent efforts, and nothing will save it. So one afternoon in late July, a fortunate thing occurred. The sky turned a peculiar green, lightning flashed, and windows in the "Loop" blew in. A moment later the sun shone. With mingled feelings I drove to the Wrigley Building. It had a curious bare appearance in the sunshine. Pieces of our antenna were picked up in all directions for weeks. As I remember, we had used acid flux when putting it up originally.

But sometime before this, Donnelley and I had realized that it is almost impossible to put up a decent antenna on a tower-like building, so we began making overtures to the Drakes, deeply affected by thoughts of the reinforced concrete understructure the deep courts, and the sixty-foot steel masts the corners of the roof. One of the directors of the Whitestone Company, which operates the Drake Hotel, had unfortunately heard the old station, but the idea went over regardless. So immediately after the windstorm, we moved an astounding collection of junk into the two handball courts and dressing room on top of the Drake. These were not in much demand, and would make marvelous studios and transmitter room. The dressing-room faced the south court, so we set the old 100-watt job up there and with tremendous effort strung a huge T antenna between the southeast and southwest flag masts.





THE ORIGINAL STUDIO EQUIPMENT AT THE DRAKE HOTEL  
The pale blue parrot cage support is visible. It holds the signal lamp

Sixty feet under it we rigged a fan counterpoise. This was a success from the start. One ampere sent into it would raise the dead.

In the meantime I had been working as I never intend to again, building a one-kilowatt set. This was of the power amplifier type for the simple reason that it cost just half as much as the usual type of large transmitter for the given rated output, using half as many tubes and half as much current. It had a 50-watt grid modulated driver and room for four  $\frac{1}{4}$ -KW tubes. Excepting our good friend E. K. Oxner, Donnelley and I were our own authorities on large power amplifiers, so when the new transmitter simply refused to work, we could go nowhere for help. After a three weeks' struggle, we gave a Sunday night concert with three amperes in the antenna. People in town phoned us to shut the rotten thing off, but a few crystal set owners called up wild with enthusiasm. They were hearing us without their antennas, and our modulation was perfect. For the next three days the mail rolled in, coming from everywhere but the West

Coast. It seems that our small output was so concentrated on just one wavelength that all tube sets within twenty miles began to back-fire when tuned to it. For some time after that, listeners with tube sets anywhere near us found it necessary to turn their tube filaments way down to get us properly.

We felt that we had something unusual, and went to work hard on the set, adding tubes and working up the radiation, half an ampere at a time. Finally the West Coast mail began to come in. It was a nightly occurrence to have listeners in the Eastern states get excited and call us on the phone, relaying our signals back to us over the land line. I recall one night when I was particularly impressed with the speed of ether wave transmission. I was at the transmitter, and the doors to the studio were open. A gentleman in Seabright, N. J. called us up and I took the call. He complimented us on the station and put one of his headphones to the telephone mouthpiece. The notes of the piano number in progress went through our broadcasting microphone and

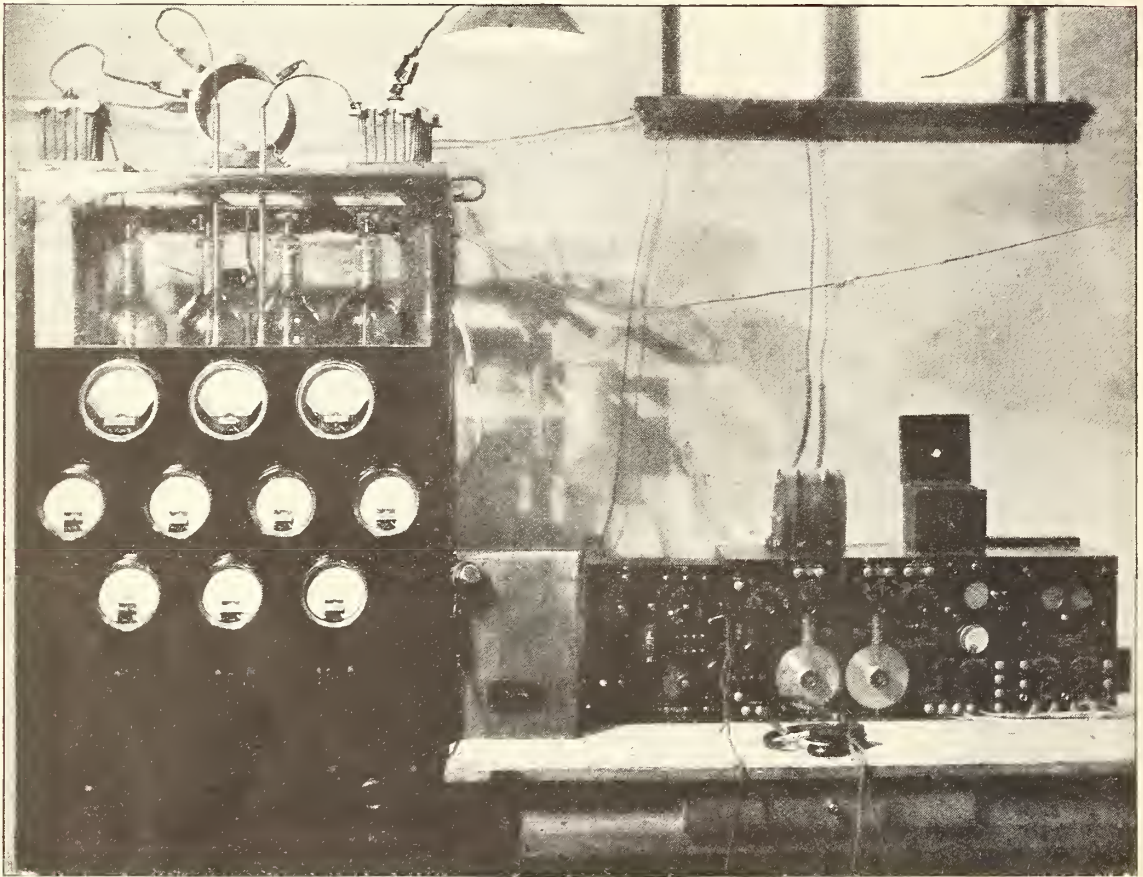

THE FIRST TRANSMITTER AT THE DRAKE HOTEL

It got its concerts as far as Surrey, England, Rio de Janeiro, Wrangel, Alaska, and to a ship 300 miles this side of Honolulu

the set to Seabright, and back to my left ear over the wires so much more quickly than they came through the air from the studio to my right ear that the difference was easily noticeable. In one case they traveled 1,800 miles; in the other, 40 feet.

I will never forget the first night we broadcasted Jack Chapman's orchestra. Our lines to the main floor had just been installed, and I went down with a microphone and put it on Jack's piano. When I got back to the transmitter room I found Donnelley and the first operator dancing violently around the place dragging a crystal monitoring set after them. Apparently everyone listening felt the same way, as our mail went from 200 to around 800 letters a day.

WDAP went off the air recently for several weeks, and all hands turned to for the completion of the new transmitter. This takes up the entire other handball court on the floor. It is in the form of a single unit of two-inch

piping and conduit work. All the generators are at one end. Then come the filter systems, input control panels, circuit breakers, and field rheostats. There are three transmitter cases in a row, the middle one containing a hundred-watt driver circuit. This may be coupled to either of the outside cabinets, which contain separate power amplifiers. In front of all this is the operating desk, with remote controls for everything and microphone lines. Way up above the structure are the tuning variometers, of  $\frac{3}{4}$  inch copper tubing. The lead-in comes through the skylight for an antenna of four long cages in the form of an X. Under the antenna is a vast counterpoise covering the entire roof of the hotel.

We went on the air with the new station Saturday, June 29th, 1923. We have great hopes for it, and letters received thus far indicate that the two years of hard work we have spent on power amplifiers was more than justified.



# “Music Hath Charms—”

BUT NOT TO SOOTHE THE TOO-SAVAGE BREAST

Of this royal prisoner at the Bronx Zoological Park, in New York. When music from a broadcasting station was turned on, Chief Keeper John Toomey was glad he was on the outside, looking in. Not all the animals lacked the musical appreciation of this lion however



(LEFT) TRYING IT ON THE BEARS

They liked it—especially the organ music—and were inspired to stand on their hind legs and crowd up close to the loud speaker

(RIGHT) “GRANDPA” FELT 600 YEARS YOUNGER

And seemed decidedly pleased with the radio music. It is estimated that “Grandpa” celebrated his 269th birthday about the year Columbus came over

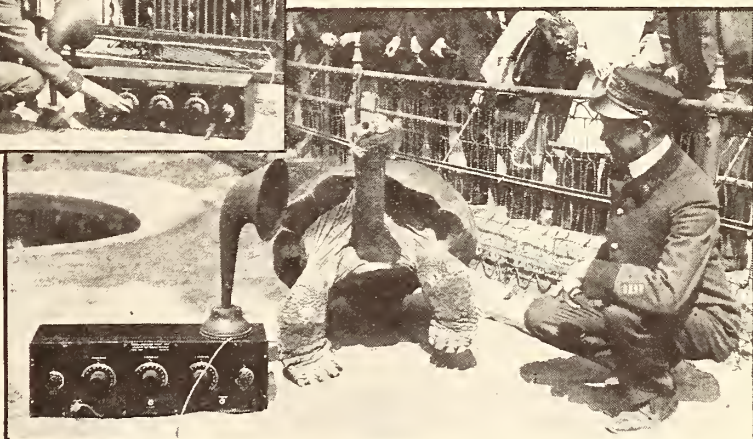

# Receiving Contest Winners



Infinite Painstaking, Excellent Workmanship and Great Originality Evidenced by the Successful Contestants. *Miss White Wins Third Place.* Three Complete Articles by the Winners. Next Month Will Appear Much "Dope" and Many Interesting Illustrations from Other Entrants—also "Honorable Mentions" and Summary

## FIRST

**Richard Bartholomew, of Garrochales, Porto Rico.** He has been sent the first prize, a De Forest D-10, 4-tube Reflex Loop Receiver. (For his article, see pp. 305-311 in the August number.)

## SECOND

**Eric G. Shalkhauser of Peoria, Illinois.** Mr. Shalkhauser wins the 150-3000-meter Grebe Tuned Radio-Frequency Amplifier. His clear and complete article on a portable Grimes "Inverse Duplex" loop receiver is full of practical help for the experimenter. His aggregate mileage of 48,745 is excellent for *loop* reception.

## THIRD

**Miss—get that!—Miss Abbye M. White, Baer Avenue, Hanover, Pennsylvania.** The originality of her home-made set and the excellent description, photos, and diagrams which she submitted were unanimously awarded the Third Prize—three vacuum tubes (choice of UV-201's, UV-199's, WD-11's or WD-12's), although her total mileage—60,595 on an outdoor antenna (96 stations more than 150 miles away of which 18 were more than 1,000 miles)—was considerably below the records of several others whose contributions did not fulfil the other requirements so well.

## FOURTH

**Harry Blumenfeld, of Cleveland, Ohio.** The winner of this prize, the Timmons Loud Speaking Unit, did all his DX work with an Armstrong three-circuit regenerative set.

Now we'll let the winners tell their own stories, and we hope that each of you will find something of particular interest and definite suggestion which you can use in your own radio work.

**L**AST month we published the winning article in the long-distance receiving contest "held to determine who has done the best with any number of tubes and any type of receiver." This month, we announce the winners of the second, third, and fourth prizes, and print their articles in full.

The great pile of manuscripts, photos, diagrams, etc., that flooded the editorial office of RADIO BROADCAST has been very carefully gone over during the last four weeks, and a rich mine of data has resulted, which, we are sure, is going to help many an enthusiast to solve his own radio difficulties and to build his own apparatus more effectively.

Some of you, unfortunately, fell down on one or more of the requirements—omitted photos, for instance, or neglected to include adequate data on the construction and operation of your sets. It was stated in the Rules of the Contest, that "manuscripts should include the following: description of set, directions or advice for constructing and operating it; any 'wrinkles' or makeshifts which you have used to advantage; photograph of your apparatus; circuit diagram; in general, anything you have to tell that will make your story more interesting and helpful." Thus in judging contributions, "the quality and interest of photographs, text, and drawings, and the originality and general effectiveness of the apparatus described" had "greater weight than the list of stations heard," although a long list of distant stations distinctly helped.

The contest winners and the prizes they have won are as follows:



# In Tune with the Infinite

The Description of a Practical, Portable, "Inverse Duplex" Receiver, with Some Interesting Remarks About its Construction and Behavior

By ERIC G. SHALKHAUSER

(SECOND PRIZE)

Articles describing the theory, construction, and operation of the Grimes "Inverse Duplex" circuit have appeared in the April, July, and August issues of RADIO BROADCAST. What Mr. Shalkhauser does in this article is to show how he has developed the Grimes circuit in a four-tube loop outfit that is portable, dependable, and rugged. Anyone who has experimented with the "Inverse Duplex" or who has had experience in building his own radio-frequency outfits, should be able to construct a set similar to Mr. Shalkhauser's from the circuit diagram and the several clear photographs published with this article. We should like to hear from those of our readers who undertake to develop outfits of this kind.—THE EDITOR.

**T**HE receiver shown in the photographs as assembled in permanent form, has gone through many stages of experimental work before the very best results were obtained. A four-tube set was finally chosen in preference to a two- or three-tube set, primarily because the small percentage of energy that a loop antenna will pick up in comparison with an out-door type necessitates much more amplification to assure satisfactory results at all times. The average listener does not realize what obstacles the radio man has to overcome and cannot understand why so many sets operate spasmodically. With this loop receiver it has been comparatively simple to tune in the West Coast



THE RUGGED CARRYING CASE

Everything is inside: 4-tube Inverse Duplex, loop, all batteries and phones. Unlike many so-called portable sets, this one is precisely what the name implies

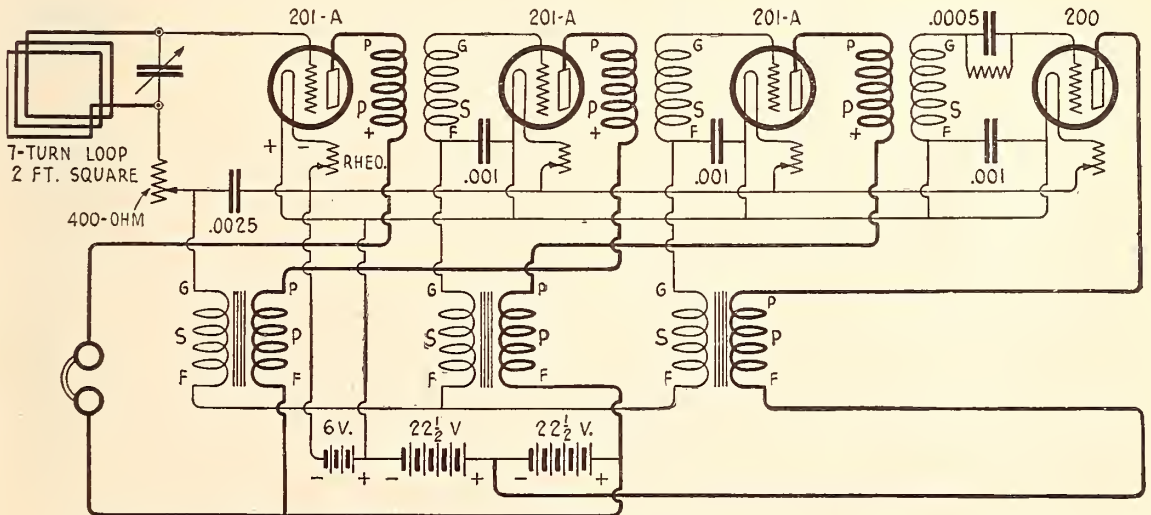

THREE RADIO AND THREE AUDIO STAGES

With a tube detector, they make up Mr. Shalkhauser's 4-tube circuit which he operates from a two-foot loop



THE RECEIVER CAN BE LIFTED RIGHT OUT

Mr. Shalkhauser showing how easy it is to get at the "works"

stations most any evening of the week, from Peoria, Ill. The distance is about 2,000 miles.

The receiver was constructed with the idea that it must be:

- 1 Easily portable (of the one-man type).
- 2 Simple yet efficient in tuning.
- 3 Rugged but sensitive.

The receiver was assembled in January of this year. Four months of experimenting with radio apparatus found on the market to-day, resulted in the combination of parts shown in the photographs. All makes and types of radio- and audio-frequency transformers available were given a trial. The various makes of tubes showed a great deal of difference when combined with these transformers.

The hook-up as at present used in the set is the Grimes "Inverse Duplex," a modification of the French Latour circuit used during the war. Using the regular Latour circuit good

results can be expected if the tubes in the second and third stages of amplification are not overloaded. This, however, is difficult to avoid with the ordinary vacuum tube, and the modification according to Grimes proves a decided advantage.

Many types of loops were tried with varying results. The size finally decided upon was a loop two feet square wound with seven turns of large-size lamp-cord wire  $\frac{3}{8}$ -inch spacing is used between the centres of adjacent turns. Connection is made with the receiving set through a plug and jack arrangement, making it possible to swing the loop in any direction desired. Good contact is assured at the same time. Not only is it possible to select stations lying in the same plane with the loop, but directional effects are experienced depending on which end of the loop is connected to the grid of the first amplifier tube. The grid end pointing to the station desired gives stronger signals than when the loop is rotated through 180 degrees. WBAD at Minneapolis lies in the same plane with Atlanta, Georgia and Peoria, Illinois. Yet by swinging the loop through 180 degrees, when both stations were sending on identically the same wavelength at the same hour, either one could be received in preference to the other. This property of the loop is not generally known.

With the potentiometer in series as shown in the diagram, selectivity is greatly increased. Stations sending close by have a tendency to paralyze the set. Putting resistance into the circuit will prevent this as the energy effecting the first amplifier tube is decreased.

The loop itself folds up in compact form and is carried in the cabinet.

Experiments were carried on with the UV-200 the UV-201, the UV-201-A, the French amplifier, the old Moorhead, and the UV-199. In connection with these tubes the various types of radio and audio-frequency transformers were tried. Since the apparatus used in the duplex circuit has fixed values almost throughout, it was necessary to choose such combinations as would give proper balancing of radio and audio currents. The UV-200, UV-201 and UV-201-A tubes have given the best all-around results. This can be explained by the fact that they have been on the market longer than the others, are manufactured under standard and well established principles and were used in the design of the transformers to meet their particular characteristics. The WD-11 and



UV-199 tubes will need specially designed transformers for best operation.

Acme radio transformers R-2, R-3 and R-4 were used for the first, second and third radio-frequency stages, respectively, and gave by far the best results. The Atwater-Kent audio transformers served best in the audio-frequency circuits. For the first and second stages the 10-1 ratios were used, for the third the 5-1 ratio. No by-pass condensers were necessary across the secondary of the audio transformers, the distributed capacity being amply large to allow the radio-frequency currents to pass.

Critical adjustments for the amplifier tubes are not essential, although it has been found desirable to place separate rheostats in each filament circuit. The detector tube has a vernier control for best results. For long distance reception the vernier adjustment is particularly useful.

Following is the list of parts used:

3 UV-201 or UV-201-A tubes . . . . .	\$19.50
1 UV-200 tube . . . . .	5.00
3 Cutler-Hammer rheostats . . . . .	3.00
1 Cutler-Hammer rheostat, vernier . . . . .	1.50
1 Kellogg .001 mfd. vernier condenser . . . . .	8.75
2 Atwater-Kent 10-1 ratio audio transformers . . . . .	10.00
1 Atwater-Kent 5-1 ratio audio transformer . . . . .	4.00
3 Acme radio transformers, R-2, R-3, R-4 . . . . .	15.00
3 Micadon .001 fixed condensers . . . . .	1.20
1 Micadon .0025 fixed condenser . . . . .	.40
1 Grid leak and condenser .0005 . . . . .	.50
2 Single-circuit jacks . . . . .	1.40
1 Acme potentiometer . . . . .	1.50
2 Round plugs . . . . .	3.00
1 Dictograph headset . . . . .	8.00
4 Dry cells . . . . .	1.80
2 22½-volt Burgess B batteries . . . . .	4.50
1 Panel . . . . .	2.40
4 Sockets . . . . .	3.00
4 Binding posts . . . . .	.20
75 feet single lamp cord . . . . .	.75

\$95.40

The most remarkable advantage of this receiver over all others lies in its simple yet very efficient tuning properties. After proper adjustment of the rheostats the condenser is the only tuning device used. Absolutely none of the characteristic whistling noises can be heard. The station tuned to merely swings in and out again as the wave is passed. Very little static interference is in evidence. It is a pleasure to work with this circuit after having been accustomed to one which is more noisy and in which every beat note can be heard through the head-phones. Using an .001 mfd. vernier condenser, the longer range of wavelengths used since May 15th can be tuned in properly. The entire set, including dry cells,



UNPACKING THE LOOP

A place is provided for it at the back of the horizontal tuning panel

weighs less than the ordinary 80-ampere-hour storage battery. It is ideal for camping trips and automobile use.

Hints for proper construction and operation:

1. Above all, avoid the ordinary kind of flux when soldering connections. Use pure rosin and good solder. This set functioned about 15 per cent. of normal the first time it was assembled after experimenting. Acid had gotten into several of the parts, particularly the by-pass condensers and jacks, and ruined them for further use. All connections must be soldered well unless good contact can be made through jacks or binding posts.
2. Use large size wire. There is a world of difference between No. 18 bell wire and No. 14 copper wire in connecting up the parts. Avoid as much as possible running wires parallel. If it is done, keep them at least one-half to one inch apart.
3. Set all radio- and audio-frequency transformers so

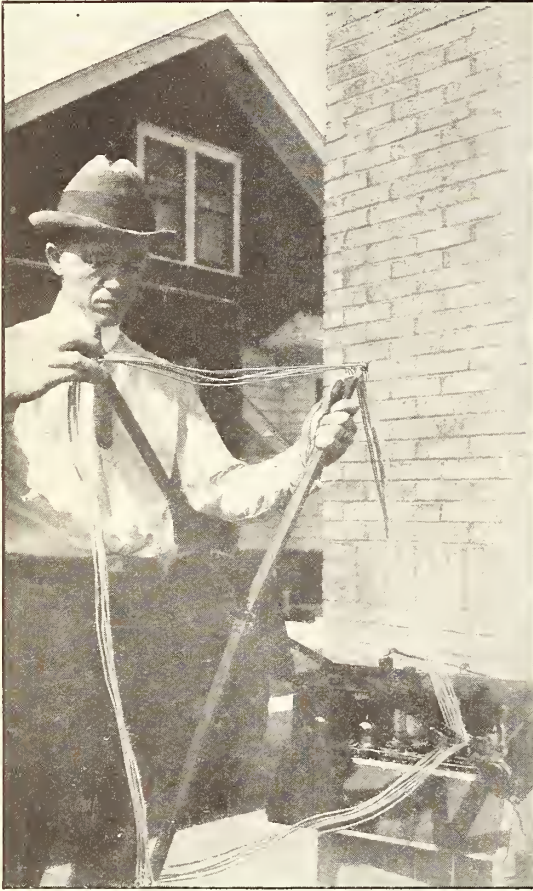

#### THE LOOP IS QUICKLY SET UP

The fact that with a set of this type you have no antenna-wire to stretch from tree to tree, or ground connection to make, is an additional argument for using the loop on a portable set

- that they stand at right angles to each other and at least four inches apart. Shielding is desirable but not essential.
4. Follow the circuit diagram when assembling the parts. I have assembled this set dozens of times and have never experienced any trouble in getting at least a few stations at the first trial made.
  5. Not all tubes function alike. The mere changing about of two amplifier tubes will often make a decided change in the signal strength.
  6. The UV-201-A amplifier is used when operating with dry cells on the filaments. Special binding posts are provided for storage battery operation with the UV-201 amplifiers.
  7. If the set is functioning properly a decided click can be heard in the head-phones when the grid connection to the first amplifier tube is touched with the moistened finger. The tubes must of

course be turned on. This is also true when the grid of the detector tube is touched.

The following is a list of stations<sup>1</sup> heard during the months of February, March, April and part of May, 1923, on the four-tube portable loop receiver, all stations having been received with such signal strength that little doubt remains about mistakes having been made:

KHJ, KWH, KYJ	Los Angeles	1,955
KUO	San Francisco	2,015
WBZ	Springfield, Mass.	1,045
WGI	Medford Hillside, Mass.	1,040
KNJ	Roswell, N. M.	1,190
PWX	Havana	1,500
KDYS	Great Falls, Mont.	1,420
WOAI	San Antonio, Tex.	1,160
WDAE	Tampa, Fla.	1,160

<sup>1</sup>EDITOR'S NOTE: As there is not space to print Mr. Shalkhauser's complete list, only the stations over 1,000 miles from Peoria, Ill. are given here.

#### THE OUTFIT READY FOR USE

The hinged front side of the cabinet might well be provided with a support and used as a desk

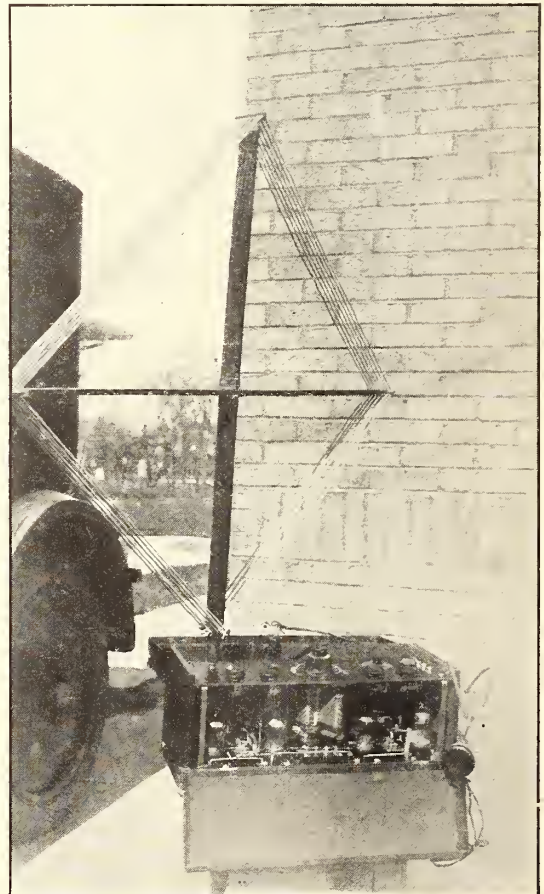



# Hearing North America

An ingenious arrangement of apparatus permitting any one of five circuits to be used

By MISS ABBYE M. WHITE

(THIRD PRIZE)

**R**ATHER fearfully I venture into your contest, for I do not know if we of the fair sex are allowed in or not. But your rules say nothing against it—so here I am.

The set I am going to describe is not so unusual except that I have at instant command any one of five different circuits—all efficient—and each having a different purpose. My set is entirely homemade—and I had great fun in constructing it.

When I first made my set I used the Reinartz circuit alone—and then, finding in it some shortcomings, I modified it to use a double-circuit which is far more selective although slightly more difficult to adjust. The original cabinet was made to accommodate a panel 8" x 10", being 5" in depth. I thus had a very compact receiver. Upon modifying it I did not change the cabinet but simply added additional binding posts on the rear—and used three spider-web coils and one extra condenser for my other hook-ups.

Before going into the actual construction of the set I wish to say something of the circuits used. The Reinartz as we all know is fairly selective as long as there is no local interference. It is particularly efficient on amateur waves—and amateur stations from every district have been copied by its use. The circuit I used has a wavelength range that goes up beyond six hundred meters, for many ships in the Atlantic have also been copied. The reason for my looking for another circuit is that station 3ACY is located about three blocks away and he is "pounding brass" with a  $\frac{1}{2}$ -KW spark all day long—hence I needed something more selective. The spider-

web coils appealed to me because they were easily constructed and offered a tuning element which had very little distributed capacity and the resistance could be much reduced and hence the tuning made very sharp. So I made three of these coils and mounted them. I tried two different circuits—one the ordinary two-circuit tuner employing tickler feed-back, and the second a modification of the efficient Weagant circuit. The latter is my favorite, but offers one objection in that the impedance of the phones enters into the tuning and an additional pair of phones cannot be added or an amplifier hooked in without retuning. The optional circuit shown by dotted lines in Fig. 1 overcomes this objection in that any number of phones can be connected or taken out without detuning.

Thus far I have described only three circuits, and you may wonder where the other two come in. They are formed by simply disconnecting the primary spider-web coil P and hooking the aerial lead to the switch lever on coil S and the ground lead to the opposite side of the same



MISS ABBYE M. WHITE

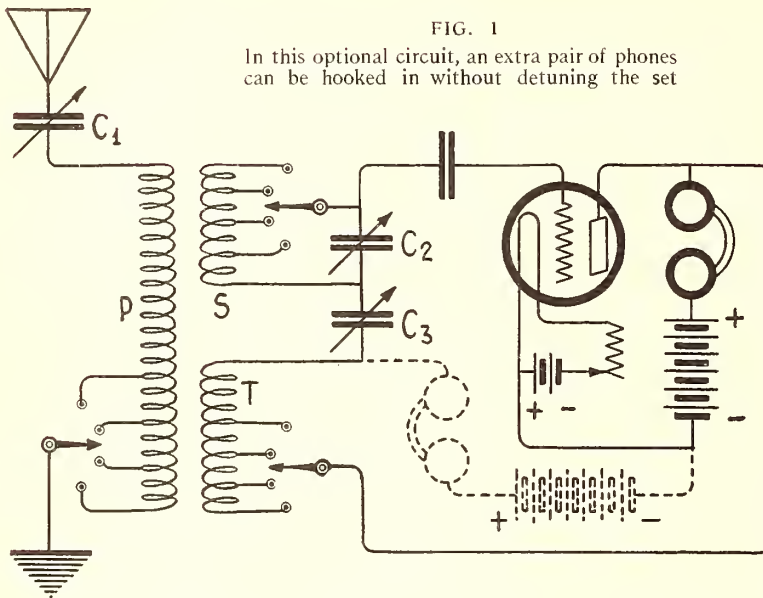

FIG. 1  
In this optional circuit, an extra pair of phones  
can be hooked in without detuning the set

coil. Thus I now have a single circuit tuner—which can be connected in either of the two methods described before. I employ the tuner in this manner late at night or when little interference is experienced, to do DX work—for I have found nothing as efficient as the single-circuit tuner for distant work. Of course, during the evening (or when 3ACY is working) I do not employ the single-circuit but use the two-circuit, since it is more selective.

Now as to the materials needed for the construction of the set.

- 1 formica panel 8" x 10"
  - 1 tube socket
  - 1 UV-200 or any other good detector tube
  - 2,4 binding posts
  - 2 porcelain knobs
  - 6 switch levers
  - 1 box brass-headed upholstery tacks
  - 1 pair phones
  - 1 6-volt A battery  
(unless dry cell tubes are used)
  - 1 B battery
  - 1 vernier rheostat
  - 2 23-plate variable condensers
  - 1 13-plate variable condenser
  - 1 pair hinges
- Odd pieces of cardboard, wood, screws, tinfoil, etc.

The approximate cost of the above, including an 80-ampere-hour A battery is about thirty-five dollars.

First I will take up the construction of the original Reinartz unit. As said, the panel was 8" x 10". The photographs will give quite an effective view of the manner in which the various units are mounted. Although many magazine articles give descriptions of this

circuit and show a coil mounted to one side of the condensers or the condensers mounted close together, I contend that the arrangement I have adopted is best for selective tuning and to eliminate body capacity. I arrived at this conclusion after much experimental work and feel justified in what I say. In the mounting shown I have my variable condensers well spaced—and not too close to the spider-web coil. As you will note from the picture of the rear view of the cabinet, (page 424) the coil stands upright and close to the panel—this arrangement

also adds to selective and sharp tuning by eliminating long leads to switch points. When I made my original set I made the switch levers out of sheet brass—the knobs were turned from walnut and the shaft made of  $\frac{3}{16}$ " brass. The contacts or switch points were of brass tacks—which are cheap and almost as effective as the regular article. I will not give any definite dimensions of the panel layout, for it is best to lay it out in accordance with the sizes of the condensers used, make of rheostat, switch lever in the photo, etc., but the general plan shown in the photo should be followed for best results. The binding posts originally used were the five lower ones shown in the photo mounted on a strip of formica.

Now as to a few specific instructions about the component parts. The spider-web coil was made on a wood form—inside diameter  $2\frac{1}{2}$ " and outside diameter  $6\frac{1}{4}$ " and had seven spokes. The material was what is known as five-ply veneer wood. The slots were cut with a hack saw and edges smoothed with a file to allow easy winding. Photo-mounting cardboard could have been used for the form. The wire used was number 23 D.C.C. and as Fig. 2 will show, the inside section of winding—the "feed-back" coil—consists of 45 turns, tapped at 0, 15, 30, and 45. Then the wire was cut and the antenna and grid winding put on. Taps were taken out at the following points, of this second winding: on 0, 1, 2, 3, 4, 5, 6, 7, 8, 9, 10, 26, 33, and 40. The first four taps from the feed-back coil were attached to the



four switch points on the right side of the panel looking at it from the front—above and to the right was mounted the 23-plate feed-back condenser  $C_3$ . Then the taps for the antenna tuning were attached to the central switch points. The 10th tap is connected as shown in Fig. 2. The last three taps—at 26, 33, and 40—were attached to three of the points on the left switch which is the grid tuning switch (a fourth point was added to make the panel symmetrical). The condenser in the left upper corner is the 13-plate one which serves to tune the receiver to the desired wavelength. The coil in mounting was not supported by any means other than the leads to the switch points themselves, this being sufficient.

As will be noticed the grid condenser is mounted on a short piece of formica fastened on porcelain knobs seen along the right side in the photograph of the rear of the cabinet. This grid condenser was one of a series made and so arranged that they were easy to change. Two brass machine screws were mounted on the formica strip and the condensers were made by wrapping tin foil with a paper dielectric on a cardboard form, one sheet of tinfoil extending beyond the paper dielectric at one end of the form and the other sheet of foil extending from the other end. Thus the connections for the condenser were made at each end by soldering to the tinfoil brass washers so spaced that the holes would be the same distance apart as were the two brass machine screws mounted on the formica. In this manner the condenser could be slipped over the screws and locked into place with a knurled nut. I found that a condenser which had about two square inches of effective area on each sheet of foil worked best. An ordinary grid condenser could be used here. The leak, when used, consisted of a strip of paper placed on the same bolts before tightening the nuts. Pencil lines were then drawn until the correct resistance was obtained. The two binding posts on the front of the panel are for connecting the phones. In making connections avoid running leads parallel—and

keep them separated as far as possible. Fig. 3 gives a view of the binding posts and the accompanying table on page 424 will show what leads are connected to the various posts. The view of the posts is shown as looking on them from the rear of the cabinet. The table also tells which posts to connect together to use the various circuits. The 13-plate condenser is always connected across from the side of the grid condenser, away from the grid to the positive of the filament and in each of the circuits serves as a tuning condenser. To eliminate to a large extent the effect of body capacity in tuning, condensers should be connected so that the movable plates are connected to the filament. Then, too, I use, instead of the dials for tuning, a rod with an insulated handle attached to the knob of the condenser—the length serving in a manner like a vernier—in that it moves over a considerable distance before the condenser plates rotate much, thus making tuning easy.

The cabinet was made of odd pieces of wood picked up and finished with walnut stain, shellac, and wax.

Now as to the three spider-web coils. The mounting is almost self explanatory from the photo—the wood used was odd bits picked up and cut to shape. The only thing different in the spider-web coils I used is that they are tapped—thus permitting sharper tuning and a broader range. The outside diameter of the forms is 6 inches, inside diameter of the primary is 2 inches, of secondary  $1\frac{3}{4}$  inches, of

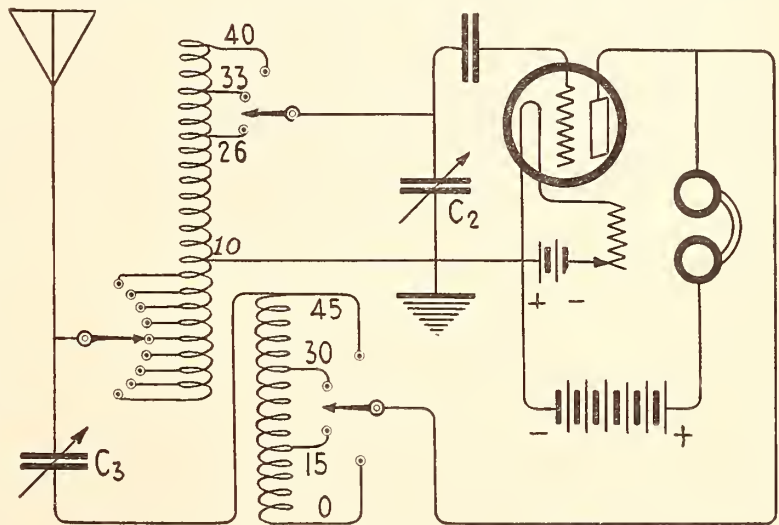

FIG. 2

The wiring diagram used by Miss White. Various circuit arrangements are produced from this by changing connections at binding posts mounted at the back of the cabinet

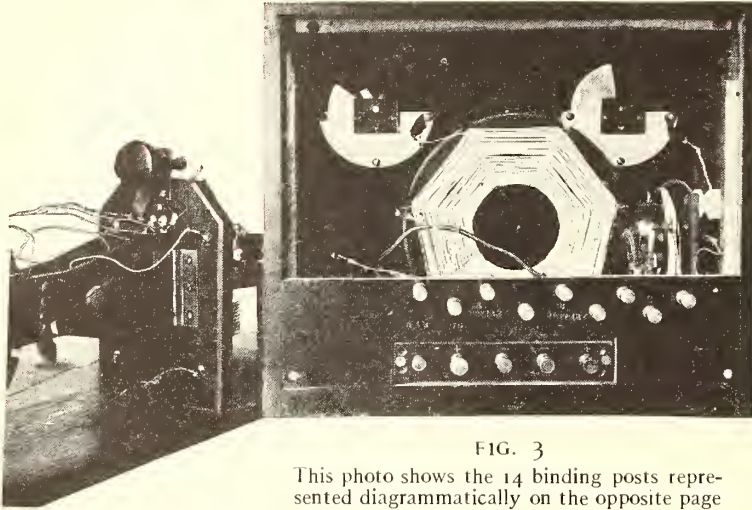

FIG. 3

This photo shows the 14 binding posts represented diagrammatically on the opposite page

tickler  $2\frac{1}{4}$  inches. All wire used in winding the coils is 23 D.C.C. and the number of spokes is 15. The forms were made of photo-mount cardboard, each having been given several coats of shellac to add stiffness and to insulate. The primary winding consisted of 50 turns—taps taken out at the 35th, 40th, 45th, and 50th turns. The secondary consisted of 60 turns—taps at 45, 50, 55, and 60. The tickler coil had 40 turns—taps at 25, 30, 35, and 40.

As will be noted, the switch levers and points on the two outside coils, which are the primary and tickler, were mounted directly on the wooden hinged arm, and the switch points for the central coil were mounted on the support on which the hinges for the other two coils are fastened. The central coil was fastened by wire supports one on each side of the coil—the lower extremities of these supports being fastened to the base of the instrument. A word of warning in making any kind of coils: never use shellac on the windings unless absolutely necessary—for it adds largely to the distributed capacity and thus “broadens” the tuning.

You will note that, when the set was modified, the additional binding posts were mounted directly on the wood, which is satisfactory if the wood is entirely dry; and it is a good plan to place the whole set and spider-web coils after mounting, near the stove or some other warm place, so as to dry the wood and the alcohol out of the shellac used to cover the woodwork.

My antenna consists of two wires about 90 feet long at a height of about 35 feet. The

earth is used as a ground but excellent results are also obtained by using the ungrounded side of the house lighting circuit as a counterpoise.

**Connections made to posts shown in Figs. 3 and 4.**

- No. 1 to one phone post on front of cabinet  
 2 to No. 4  
 3 to rheostat—other side of rheostat to one side of filament  
 4 to other side of filament  
 5 to antenna switch in Reinartz circuit  
 6 to fixed plates of 13-plate condenser and to one side of grid condenser—other side of grid condenser goes to grid  
 7 to grid switch in Reinartz circuit  
 8 to plate of vacuum tube  
 9 to 10th turn tap in Reinartz circuit  
 10 to plate switch in Reinartz circuit  
 11 to other phone post on front of cabinet  
 12 to 45th turn tap on feed-back winding of Reinartz circuit  
 13 to fixed plates in 23-plate condenser  
 14 to movable plates of 23-plate condenser

**To connect Reinartz circuit:**

- Connect post 7 to post 6  
 4 to 9 and to plus A and ground  
 8 to 10 and to 11  
 2 to minus of B battery  
 1 to plus of B battery  
 12 to 13  
 14 to 5 and to aerial  
 3 to minus of A battery

**To connect Weagant circuit:**

- Connect 8 to 11 and to one side of tickler coil  
 1 to plus of B battery  
 2 to minus of B battery  
 4 to plus of A battery  
 3 to minus of A battery  
 4 to 14 and to one side of secondary  
 6 to other side of secondary  
 13 to other side of tickler  
 Primary as shown in diagram, Fig. 1.

**To connect to optional circuit shown in Fig. 1, having made the above connections:**

- Change 11 from 8 to 13.

A little should be said about the tuning of the receiver. In the Reinartz circuit, the feed-back condenser is set so that it is about half its maximum capacity in the circuit—and the feed-back switch placed on the point to which the 15th tap is connected. Now, then, the grid switch is placed on the 40th tap and the antenna switch tried on various points, while the circuit is tuned with the tuning condenser—the 13-plate one—final tuning being done with the feed-back condenser. If signals



do not come through, another antenna tap is tried and the same procedure followed. For amateur waves, the 33-turn grid tap is used. It may be found that a different tap on the feed-back coil will work better. After a little experimenting tuning will be easy.

With the spider-web coils it may be found that on first connecting them, the set may not regenerate. If this is the case, change the leads to the tickler or feed-back coil and the set should work properly. For general work, a rather loose coupling on the coils is desirable, thus giving less interference—with but little decrease in signal strength. The circuit can be tuned by moving the coils closer or farther apart, although it is easier and better to use the condensers as the tuning elements. The spider-web coils cover a wave range considerably above 700 meters, for NAA comes pounding through on 712.

I have on various trials been able to receive phone from as far as Chicago, Atlanta, and other places with only a piece of wire strung

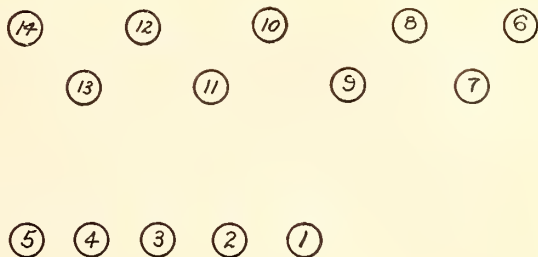

FIG. 4

The arrangement of binding posts referred to in the table of connections on the opposite page

around on the floor of the room as an aerial, using the Weagant circuit connected as a single circuit. On the whole, my set has afforded me much pleasure and has not given the trouble that sets seem to give most people in the radio game. I can travel over the United States and yet remain at home. Nightly I visit most of the larger cities in the U. S. and get much interesting entertainment and instruction.

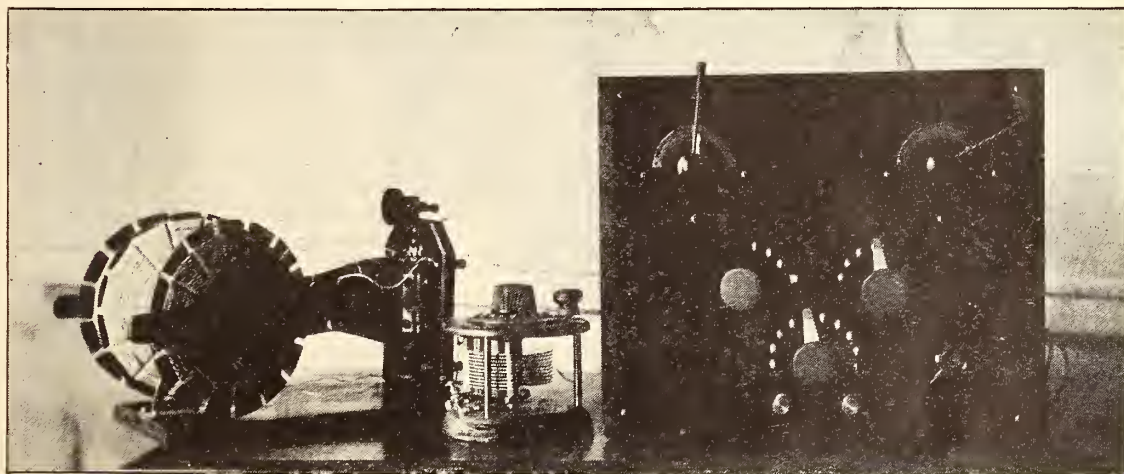

FIG. 5

Miss White's complete receiver, showing home-made spider-webs and mounting. Note also the tuning rods attached to the two condenser knobs on the panel

## In Radio Broadcast's "Lab"

While trying the many receivers sent us by various manufacturers and while experimenting with all sorts of trick hook-ups, we find out some interesting things. If you are of an experimental nature, you must find similar circumstances in your own radio laboratory—whether it be a neat, well-equipped workshop, or a table of junk in one corner of your room.

Each month we are going to describe our findings in a new department which we expect will suggest to you many interesting lines along which to conduct your own experiments, as well as to give definite reports of the performance of all manner of radio apparatus.—THE EDITOR.

# The World at Your Finger Tips

After All is Said and Done, the Receiver for the Fellow Who Wants Real Results for a Limited Expenditure is the Good Old Armstrong Three-Circuit Regenerator

By H. BLUMENFELD

(FOURTH PRIZE)

**B**OY! Page the radio bug who sits up night after night and twirls dials until his fingers ache and his wrist is all bent out of shape, yet doesn't get a thing. For I have something to tell him.

Do you want a real DX receiver? Then spare a few moments and read the following:

After experimenting for more than a year on various types of hook-ups—single-circuit, two-circuit, three-circuit, super-regenerative, Flewelling, reflex, Reinartz, and various types of radio-frequency circuits, I have at last settled down on the simple, but *ultra-efficient* three-circuit regenerative circuit.

We are now going to work by the process of elimination. You may argue that the three-circuit set is pretty complicated for the amateur to operate as there are too many controls. Of course this set is practical, but since May 15th, 1923, when all stations went on separate wavelengths, all of these controls became unnecessary.

So why not be economical and get the same, if not better re-

sults? The super-regenerative and the Flewelling sets are only in their early stages of development, and seem to produce results, but they are not very stable in DX work, as yet.

The reflex set is another set that is hard to build (although very satisfactory if built properly.) Therefore, for the novice the only set that it is advisable to stick to and experiment with is one employing the Armstrong single- or three-circuit system of regeneration.

The single-circuit set is not very selective for DX work, therefore there is but one *good* circuit left, and that is the famous Armstrong three-circuit receiver.

It is very selective and brings in nearly all the important broadcasting stations you can think of.

The advantages of this circuit are:

- (1) Ease in tuning in distant stations.
- (2) Economical.
- (3) Only 4 controls necessary. (Condenser, Coupler, Variometer, and Rheostat.)
- (4) Not complicated.

But there is a small phrase behind this efficient set that makes it work wonderfully well on local and distant stations.

It is, "Use the right parts in their right places."

The following are the complete

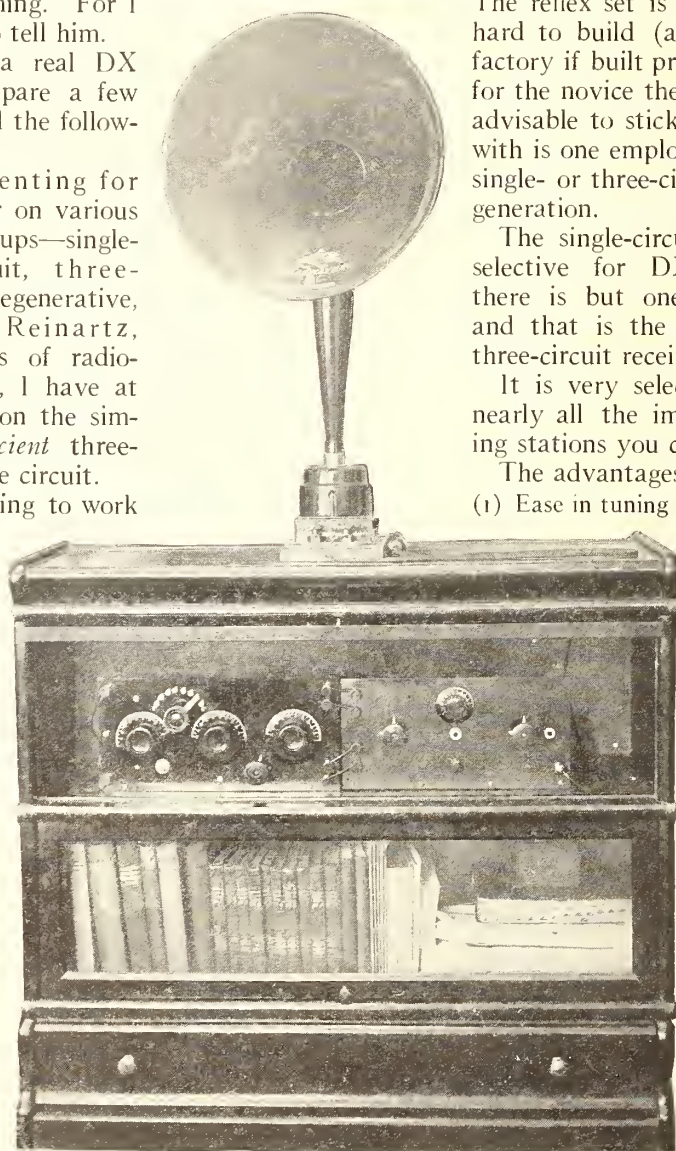

OUT OF THE WAY, YET HANDY



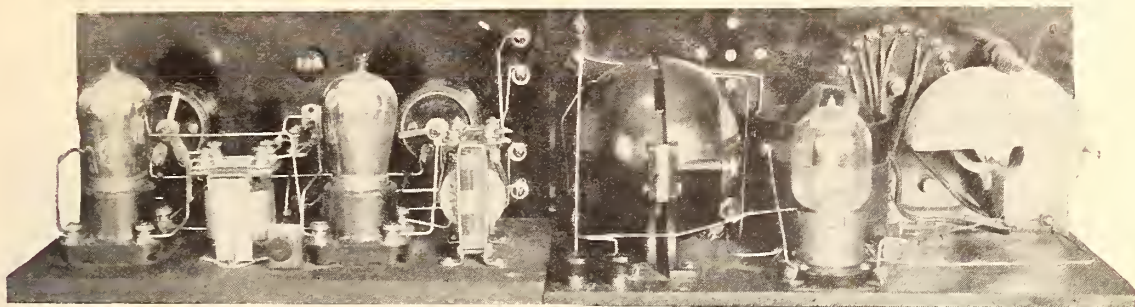

MR. BLUMENFELD'S COMPLETE RECEIVER

It is a three-circuit regenerator with two stages of audio amplification

parts needed to build this set which is equipped with a two-stage amplifier for additional volume:

## PARTS NEEDED FOR DETECTOR AND TUNER

- 1 Coupler
- 1 Variable condenser
- 1 Variometer
- 1 Rheostat (vernier type)
- 1 Socket
- 1 Vacuum tube
- 8 Binding posts
- 1 Panel (7 x 12 x  $\frac{3}{8}$ ) (Formica or Bakelite)
- 1 Base (6 x 12 x  $\frac{3}{16}$ ) (mahogany)
- 1 Grid leak and condenser (.00025 Mfd.)
- 1 Switch arm
- 8 Taps and 2 stops
- 1 Jack (closed circuit)

## PARTS NEEDED FOR AMPLIFIER

- 2 Audio-frequency transformers
- 2 Vacuum tubes (UV-201-A recommended)
- 2 Rheostats
- 2 Sockets
- 2 Jacks (one double-circuit and one open-circuit)
- 1 Panel (7 x 12 x  $\frac{3}{16}$ )
- 1 A battery switch
- 5 Binding Posts

## ACCESSORIES

- 25 Ft. tinned copper wire
- 1 Doz. flat head wood screws (brass)
- 1 Storage B battery of 68 volts. or 3 22½-volt dry B batteries
- 1 80- to 120-ampere-hour storage A battery (6 volts) or dry cells if dry-cell tubes are used
- 1 Pair of phones and horn
- 5 Clips for A and B batteries

## OPTIONAL

- 1 Book case as shown in photograph
- 1 Dozen small flexible cords for connecting set to back of cabinet.

In the detector circuit I have found a variometer in the grid circuit unnecessary.

The panel is a very important factor in your set. Bakelite is handsome and glossy and

will last for years. Keep in mind that every radio bug takes a great pride in the looks of his set.

Bear in mind, if you buy cheap parts, you will get cheap results; and if you buy high grade parts, you will get results accordingly. This does not mean that you must buy high priced parts. By no means. But buy shrewdly and carefully. You won't be sorry.

The condenser is one of the most essential parts for this circuit unless a variometer is used to tune the secondary circuit. So, when you get one, get a good one. And then purchase a vernier of the button type which has a little beveled edge (rubber) which meets the bevel side of the dial.

Any good variometer may be used.

So much for the detector. The amplifier:

Most any transformer can amplify of course. Never doubt it. But many of them will cause howling, hissing, produce distortion, in fact everything but real music.

So a good transformer is very essential to any set.

Two steps of amplification are required on this set, which will work a loud-speaker in excellent shape.

Make all connections as short as possible, and solder them carefully. Do not run any wires parallel for any long distance. The aerial should be a single wire at least 75 feet long and not more than 150 feet long and about 30 or more feet high.

On a cold, clear night this set reaches out its long hand and simply grabs the distant stations.

On local stations, the signals should roar in with terrific volume. In three months I have heard 196 stations 150 or more miles from my home in Cleveland. My total mileage is 145,179 miles.

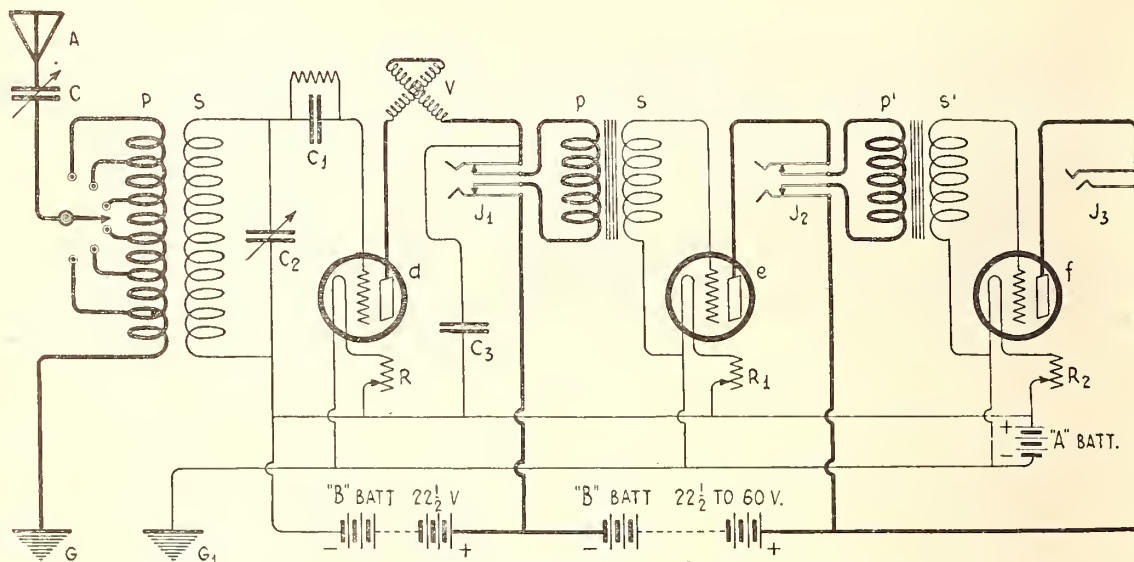

THE THREE-CIRCUIT REGENERATIVE CIRCUIT

It is very common and quite old, but it is still delivering the goods. The two stages of audio amplification make possible the use of a loud speaker. The parts include A, antenna; C, antenna series condenser (.0005 mfd); P, primary of variocoupler; G, ground; S, secondary of variocoupler; C<sub>g</sub>, secondary tuning condenser (.0005 mfd); C<sub>1</sub>, grid condenser and leak; d, detector tube; R, R<sub>1</sub>, and R<sub>2</sub>, rheostats; G<sub>1</sub>, ground from negative of A battery; V, plate variometer; C<sub>2</sub>, telephone condenser; (.002 mfd); J<sub>1</sub> and J<sub>2</sub>, circuit-closing jacks; J<sub>3</sub>, open-circuit jack

The enclosed photos speak for themselves. There is no need for the reader to have a panel layout. Perhaps the layout does not suit him. But, for the radio bug who does not want to take the time to lay out a set, the photo shows very clearly how to do it, as well as how to mount the set, which when finished will look as well, especially to its maker, as the highest priced set on the market.

In the B battery circuit will be seen a .25-ampere fuse. This is used because the A and B battery wires might become crossed accidentally and burn out the tube. This is very expensive in the end as a tube costs quite a bit of money nowadays. So with this method,

the fuse will burn out instead of the tube and the former is much the less expensive.

A variable condenser of .005 mfd. may be put across the secondary of the variocoupler for greater selectivity, although this is not necessary.

If possible, use a separate ground for the negative filament.

This set when finished and put into a cabinet as shown, will look very well.

You will just blush with pride when a person looking at the set says, "My, what a beautiful set."

And not only that—but it works, and it works well.

## In the Wake of the Winners

The response to the Receiving Contest was not limited by the boundaries of the United States. Reports from Canada, England, Porto Rico, and ships at sea poured into the editorial office. Some of these were almost undecipherable scribbles on both sides of small slips of paper; others were neatly typewritten sheets accompanied by excellent photos and full of material that is bound to intrigue the interest of any broadcast fan. Next month, we will announce the Honorable Mention contestants, and will print as much of their contributions as space permits. A summary of the contest results, together with some general conclusions about broadcast receiving, will also appear.

—THE EDITOR.



# Broadcasters in New York, Paris, and Los Angeles

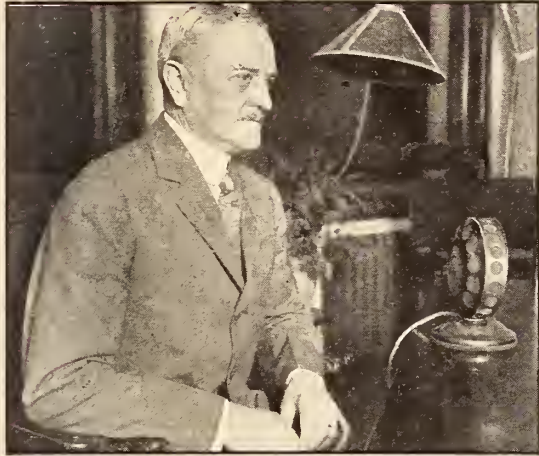

GENERAL PERSHING TALKS TO A MILLION

At least that number, it is estimated, heard his recent speech given at WEAJ (New York) and rebroadcasted by WCAP (Washington, D. C.) and WMAJ (Dartmouth, Mass.)



A SPANISH POET AT A FRENCH STATION

M. Carnido is shown broadcasting some of his own poetry through the Eiffel Tower station, in the town called Paris



THIS SEXTETTE FURNISHES IRRESISTIBLE DANCE MUSIC FOR KHJ'S AUDIENCES

It is the Filipino String Sextette from the Bluebird Cafeteria in Los Angeles. The four steps of banjo-frequency amplification, violin detector, and one base guitar form a hook-up that is exceedingly popular throughout the West



# What You Should Know About Condensers

Molecules, Elements, Conductors, and Dielectrics. The Action of Electrons at Condenser Plates. Capacity, Inductance, and Resistance

By ALLEN D. CARDWELL

## PART I

If receiving set owners would buy their variable condensers after a survey of the mechanical and electrical characteristics of the types on sale, rather than from a comparison merely of general appearance, hearsay and price, there would be less trouble with thousands of receiving sets and less apparatus of inferior quality on the market. Of course, to the uninitiated, a 43-plate condenser, for instance, is simply one unit in a collection of junk that he has to buy and connect up before he can hear the evening programs. So he trots down to the store, looks at his list and buys, among other things, "1 variable condenser (43-plate)." Now, when we are dealing in electrical circuits passing inconceivably weak currents, *the best is none too good* in a condenser to be used in these circuits. It seems to us, then, that a familiarity with good and bad condenser construction is worth any enthusiast's while to obtain; and we feel sure that any one who reads the two installments of this article by Mr. Cardwell, will find the knowledge he has gained to be of practical dollar-and-cents value to him.—THE EDITOR.

**R**ECENT research into the nature of electrical phenomena has given us substantial ground work on which to rationalize the rather complex theory of condensers and their effects. We no longer say that electricity is a

"current" and do not have to avoid specifying what it is. To-day we understand electricity to be a characteristic movement of electrons. We can explain practically all radio problems on the electron theory, and it is hardly possible to understand the action of condensers without some general idea of electron currents and their characteristic effects.

### THE CHEMICAL BASIS OF ELECTRICAL ENERGY

**T**HE first approach toward electron study begins with chemistry. If we take any substance, we can break it down into certain chemical units which are called molecules. The molecule is the smallest unit of the material which will look, taste, smell, or react with the characteristic effects of the substance as a whole. For example, pure water always looks the same, tastes the same, and will interact in the same way with other given substances. The material we call water is a liquid, the smallest unit of which is the molecule. If we break

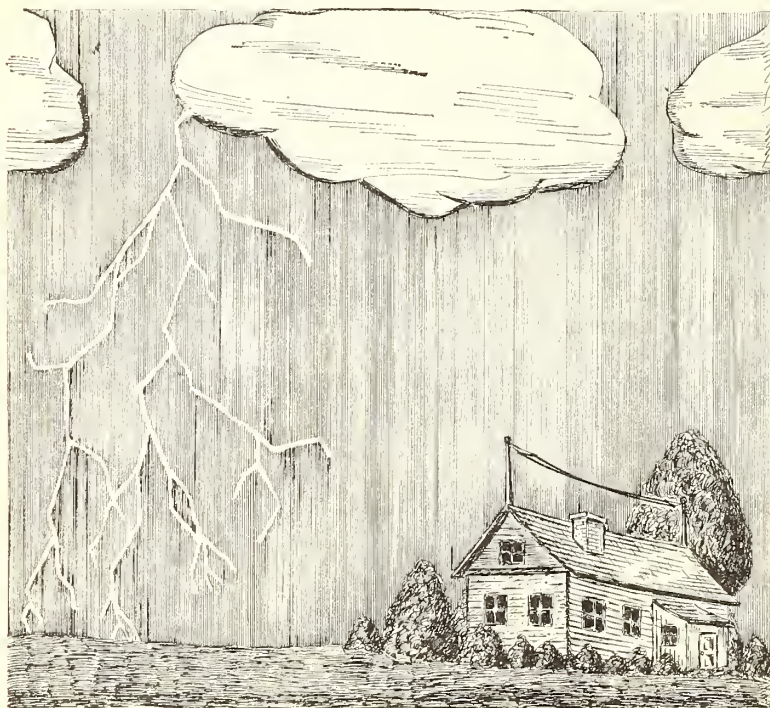

NATURAL CONDENSERS—STORM CLOUDS  
The lightning discharge illustrates the rupture of the dielectric



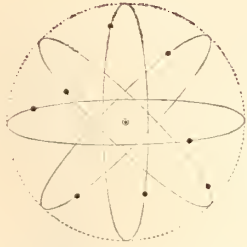

FIG. 1

Electron orbits about an atom. A theoretical illustration to visualize the general idea. The orbits are not necessarily in the same circumference, nor has it been proven that they revolve, some asserting that the electrons have a reciprocating motion

up the molecule by proper chemical agencies, we can further reduce its component units into indivisible particles which we call elements. There are some 80-odd elements that have been discovered thus far, from which we build up the entire physical universe—rocks, trees, animal life, metals, etc. Some of the elements are found in nature in a pure state; for example, a diamond is nearly pure carbon. Gold, silver, lead, etc., are 'metallic' elements often found isolated or uncombined with other elements. The elements are the units which give us by characteristic combinations, molecules and the molecules in turn give us the distinguishing qualities of any uniform or homogeneous substance such as sugar, water, air, granite, iron ore, etc. (Homogeneous does not include mixtures such as plaster, sealing wax, glass, etc.) We can go further, however, and break up the molecules into groups of atoms and these in turn we find are composed of characteristic combinations of electrons. The number of electrons in a characteristic group determines the atom, and the groups of atoms determine the molecule. All electrons are identical regardless of what molecule or element they may be a part of. The only distinguishing characteristic of an electron is its electrical state, it may either possess an electrical charge or it may be lacking in electrical energy. The average number of electrons without charges are counterbalanced by a like number with charges in the normal conductor which possesses no difference of potential between any given points. A preponderance of charged electrons or non-charged electrons will cause a difference of potential and a flow of electrical energy. Electrons which are similarly charged tend to repel one another so that in a conductor which possesses a preponderance of charged electrons this phenomena of mutual repulsion causes an equal distribution of current-carrying electrons, inasmuch as wherever there is a greater gathering of similarly charged electrons there is also a greater tendency to disperse them. It may

seem absurd to reduce all forms of matter to one common base, but science has vindicated the conception of the atom as an aggregation of electrons revolving in fixed orbits about a neutral centre.

Electrons have these peculiarities:

1. They revolve about the neutral centre of the atom in fixed orbits (Fig. 1) at very high velocities (50 miles a second approximately.)
2. They are affected by heat and their speed increases at higher temperatures.
3. Some electrons are positive and some are negative in their electrical charge.
4. The weight of an electron has been calculated. Hence, electrical energy has weight!
5. The tension with which the electrons are bound together in the atom combination determines the relative "conductivity" or "insulation strength" of the substance formed by the electrons of the atoms in the molecules of the material.

CONDUCTORS AND DIELECTRICS

WE FIND that substances which are classed as "conductors" are such because some electrons in the atoms composing the material can be dislodged. That is, certain groups of electrons in each atom are revolving in outer orbits of the atoms and can be made to jump from atom to atom or into space. Elements, such as iron, aluminum, copper and silver, etc. are good conductors. The atomic weights are relatively high, and there are a larger number of electrons per atom. This gives us more active or floating electrons to serve as current carriers, but in all cases where these electrons are charged, they are called negative electrons. The positive electrons are not detachable from their atom base or centre. If by chemical or mechanical means, we withdraw some of these

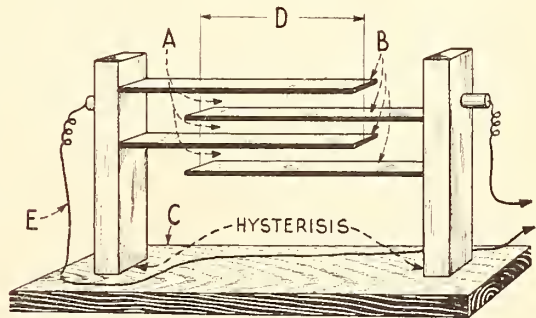

FIG. 2

Factors in condenser ratings: A—dielectric, its character and thickness; B—area and number of plates; C—insulator; D—surfaces opposed; E—stray fields

negative electrons from a conductor, such as a wire, we make a current flow because there is created a shortage of electrons along the wire. The actual movement of the electrons is not direct along the wire. The electrons are measured in billions per inch of wire and their normal motions are very erratic so that a difference in potential at two points on a circuit creates only an "average" movement in

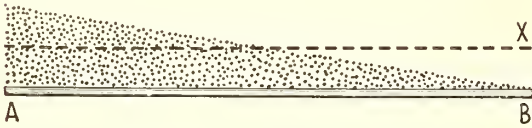

FIG. 3

Showing the gradient of current pressure (electron density) on a wire. At A the electrons are excessive and a current will flow to B until the common level is on line X. The density is obviously a "cone" field about the wire, but for purposes of simplicity it is shown only as a vertical plane above the wire

one direction. This may be illustrated by the movement of a mob of people about a theatre or ball park entrance who may push and jam toward the doors, but a relatively small number actually pass in, during a given interval of time although the average or "net" push of the crowd can be tremendous, especially for those who happen to be near the gates or wall. The electrons in a conductor which can thus be used to set up an electric current are termed free electrons. Their speed, or average movement, depends upon the steepness of the "grade" created by an impressed force or shortage of electrons created at any point (Fig. 3) just as the speed with which a car will roll down hill depends upon the slope of the hill. It has been pointed out that approximately only one in 5,000 electrons resident in a conductor actually is used when a current is flowing through the conductor. In conductors the electrons are moving in all directions freely and wherever an electron dislodges another from an atom, the space left by the dislodged electron is filled by another electron from some other part of the conductor.

In non-conducting materials, so called, we have electrons which relatively are not free. They are so tightly bound to the neutral or centre of the atom that only extreme pressures can dislodge them. Such materials as hard rubber, air, Formica, Bakelite, etc. are of this type. There are no free electrons in insulators although electrical pressure can be applied and its effect noticed at a distance in the insulator,

much in the same manner as a group of billiard balls may transmit the power of the impact of the cue ball providing a group of balls are already in physical contact. It is by forcing them out of their normal locations that we can make a condenser store electrical energy.

#### THE ACTION OF ELECTRONS AT CONDENSER PLATES

ASSUME that a potential of positive polarity is applied to one of the opposing plates. That means that one wall of the condenser will become crowded with free electrons and the other wall will be lacking in a sufficient number of electrons to satisfy the atoms in the conducting material (Fig. 4). Accordingly there will be an effect transferred to the dielectric between the plates which is an electrostatic strain or displacement. Although the electrons of the dielectric are not free to move permanently they can shift out of place. At the positive plate, they will be pushed back by the accumulation of electrons there. At the negative side they will be pulled toward the plate. Yet in neither case will they actually move out of the dielectric to the conductor or out of the conductor to the dielectric, otherwise the current would move immediately in one direction and not store up energy. This congestion or concentration of the electrostatic strains or lines of force exerted by the accumulation of electrons within a restricted area accounts for the term "condenser."

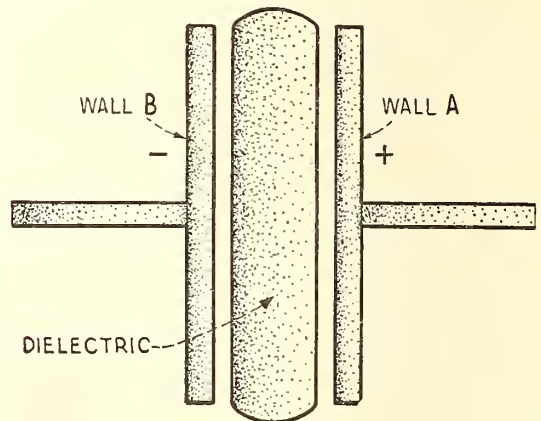

FIG. 4

Condition of electron congestion of a charged condenser. (The dielectric is shown as a separated "unit" in the centre, but actually is in contact with the wall surfaces A and B.) The stippling illustrates how the electrons crowd up on the inside wall of the A plate, thus pushing the dielectric electrons toward, *but not to*, the B plate, where the strain causes the electrons in the B plate to move away from the dielectric



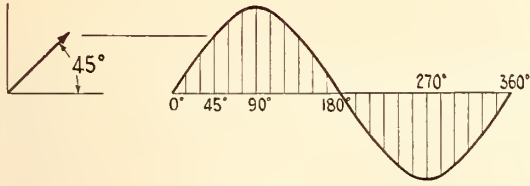

FIG. 5

Showing how a counter clockwise rotating voltage or current, or both, can be made to represent a "sine" curve when plotted against time. Each position on the curve thus has an "angular" value, used constantly in mathematical calculation

The closer the conducting walls and the greater the areas of their opposing surfaces, the greater their capacity to hold electrical energy. A condenser cannot exist without a dielectric or insulating medium. If the opposing surfaces are separated by air, air is the dielectric. If separated by mica, then mica is the dielectric. The dielectric must necessarily be a non-conductor. This explains why the electron theory is vital to the proper understanding of condensers.

The dielectric, therefore, absorbs a certain amount of electricity and holds it in suspension until the potential used to move the free electrons is removed or reduced.

When the condenser walls are short circuited, the stored energy is permitted to discharge itself and a current is set up in an opposite direction to that of the original charge. Note that there are thus two currents: the current of free electrons in the conductor and the current of the movable but restricted electrons in the dielectric. The first is a conduction current and the second a displacement current. This distinction is fundamental.

If the impressing electromotive force (the push or pull of electrons along the circuit) is great, it may cause such a strain upon the electrons in the dielectric that the free electrons will break through the dielectric and flash as a spark discharge, in which case they pass physically through the dielectric whether it be glass, air, mica or what not and actually "puncture" the insulating medium. Thus storm clouds accumulate electric potentials which are built up until they are so great that they break down the insulation of the air and lightning is discharged from cloud to cloud or to the ground.

In radio receiving circuits we are dealing with extremely small voltages, so minute that it is practically impossible to construct a condenser with walls so close together that a spark could

be passed by the voltage set up from a received signal. The "puncture voltage" of a receiving condenser is therefore not important. (Static charges, however, even on small aerials, will build up potentials of a thousand volts or more and cause considerable sparking across the condenser walls.) It is of vital importance, however, to preserve all the variations in voltage and current of the received signal regardless of how weak it may be. This involves certain resistance effects of high-frequency, alternating currents, and only by understanding them can we appreciate the importance of correct condenser design.

CAPACITY, INDUCTANCE, AND RESISTANCE

EVERY alternating current circuit exhibits three properties in variable proportions. There will be some capacity, some resistance and some inductance regardless of whether they are wanted or not. We find, also, that every circuit will respond or be most easily disturbed by an alternating current of one definite frequency more readily than by any other frequency. The frequency may be ten oscillations (charges and discharges) of the current through the circuit in one second, or it may be one million oscillations in one second.

An excellent analogy may be drawn from the use of a tuning fork (Fig. 8). If struck, it vibrates and emits a note. The tines thus represent three physical effects: (1) the compression swing which we may call the condenser, (2) the inertia pull at the end of each swing which is typical of the inductance drag, and (3) the air resistance equal to the circuit resistance. If the fork is put in a sealed tube and the air pumped out, the fork will oscillate for a much

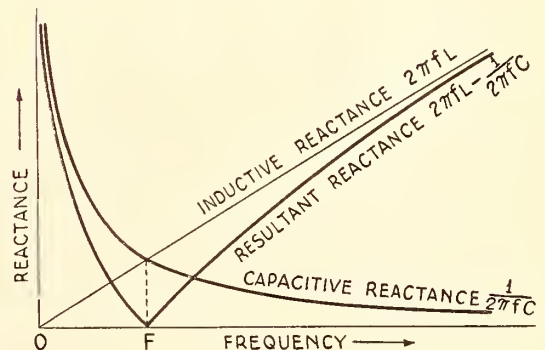

FIG. 6

Reactance curves, showing how the capacitive reactance and the inductive reactance are neutralized at resonance, shown at point F

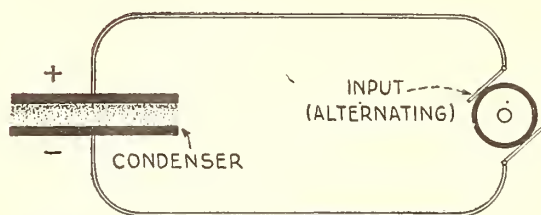

FIG. 7

Condition of electron displacement in the dielectric on one phase in an alternating current

longer period although no sound can be heard from it. The frequency with which the fork vibrates depends upon the length, weight and elasticity of the tines.

If, therefore, two tuning forks of the same frequency on a board, we can strike one and its vibrations carried through the air or along the board will cause the second fork to begin to vibrate. This is due to the fact that a slight disturbance of the same frequency as that of the fork causes it to vibrate and if the disturbance is prolonged, the two forks vibrate continuously for some time.

If, therefore, we wish to secure a signal from a certain station, we adjust our receiving circuit so that it will oscillate or alternate in potential and current with the exact frequency of the wave used by the transmitter. Then any variation in the amount of current sent from the transmitting antenna and to the receiving circuit is acting upon a highly sensitive mechanism which is so critically balanced that it will oscillate.

In this resonant circuit we must hold the resistances down in every way. Hence, we will return to the condenser part of the circuit and limit the discussion to a definite range of frequencies.

For wavelengths of 220 meters we are detecting currents that alternate at 1,363,500 alternations per second. For waves up to 700, the frequency is down to 428,600 alternations per second. For 350 meters our condenser must

charge and discharge 857,100 times a second.

#### LOSSES IN CONDENSERS

THE first thing we observe when a condenser is used in a high-frequency circuit is that the current may be dissipated in the dielectric. Thus, if we force 1 ampere of current into a condenser and when it discharges we only get back .9 amperes, there has been a dielectric loss of .1 amperes due to the creepage across the space between the plates. Some of the current must have "leaked" through the dielectric or have been absorbed in the dielectric itself. These losses are normally too small to measure when the dielectric is only dry air, but under certain conditions the leakage can increase to an appreciable extent. In a solid dielectric, this loss is always appreciable and accounts in one way for the preference of radio engineers in using air as a dielectric wherever possible

FIG. 8

When the tuning fork is moving as in A, its spring is compressing, but its momentum is decreasing. In B, its spring is released and the momentum forces the lines to swing outward and accumulate an opposite spring tension. In C, the momentum and the spring effects are at the neutralized point where spring effect equals momentum, and the direction of motion changes with the spring effect inward exceeding the momentum outward. Any piece of steel or other springy material has a natural period of vibration just as an electrical circuit

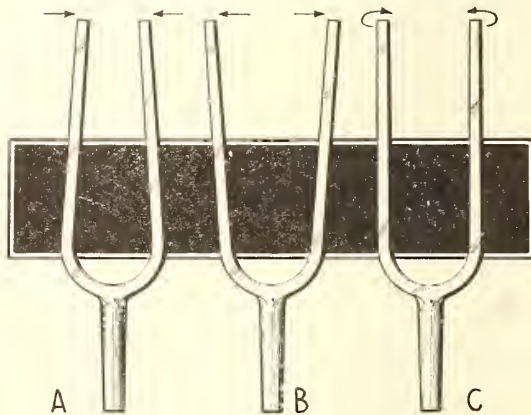

*The second and final part of this article will appear next month. It will deal with further kinds of losses in condensers, variable air condensers for radio use, disadvantages of the conventional form of condenser, the best materials for condensers, and condenser ratings.*





# The Grid

## QUESTIONS AND ANSWERS

The Grid is a Question and Answer Department maintained especially for the radio amateurs. Full answers will be given wherever possible. In answering questions, those of a like nature will be grouped together and answered by one article. Every effort will be made to keep the answers simple and direct, yet fully self-explanatory. Questions should be addressed to Editor, "The Grid," RADIO BROADCAST, Garden City, N. Y.

### ADAPTING YOUR THREE-CIRCUIT RECEIVER TO THE NEW WAVELENGTHS

THE allotment of higher waves to broadcasting stations has made necessary the loading of many receivers in order to preserve efficient reception over the entire wave range. The majority of enthusiasts have found it a comparatively simple matter to load up the single-circuit sets. Generally their own ingenuity has pointed out the necessity of adding merely a few more turns of wire to the main inductance. The wave shift with the honeycomb sets is less complicated and is effected by using slightly larger coils in primary, secondary, and if necessary, in the tickler.

The variocoupler-twin-variometer set, however, presents somewhat of a problem, and RADIO BROADCAST has been the recipient of numerous inquiries as to the most efficient method of loading apparatus of this type.

There are two basic ways in which this may be accomplished: by the addition of inductance, and by the addition of capacity. The first method is perhaps the most efficient and at the same time most simple. The loading coil consists of ten turns of wire on a two and a half inch diameter tube (or simply wound about the fingers), inserted in series with the grid variometer and secondary, as is shown in Fig. 1. A small panel switch is included across

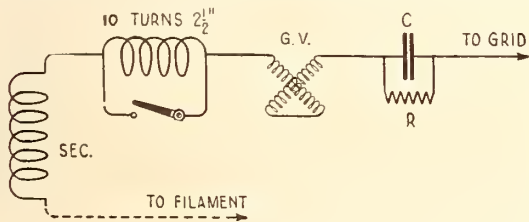

FIG. 1

A loading coil—10 turns of wire on a 2½-inch tube, raises the wavelength of the secondary circuit. If the antenna is a fairly long one, it is generally unnecessary to load the primary circuit

the extra inductance for shorting during short-wave reception. The loading coil may be placed within the cabinet, care being taken to locate it in such a manner that it is not in inductive relation (near and parallel) to other coils of the set. If placed too near other inductances, the load may absorb energy when shorted and lessen the general efficiency of the apparatus.

The addition of a small capacity across the secondary of the variocoupler and the grid variometer (Fig. 2) will also boost the wave well above the broadcasting frequencies, and into the path of six hundred meter traffic, a wave-

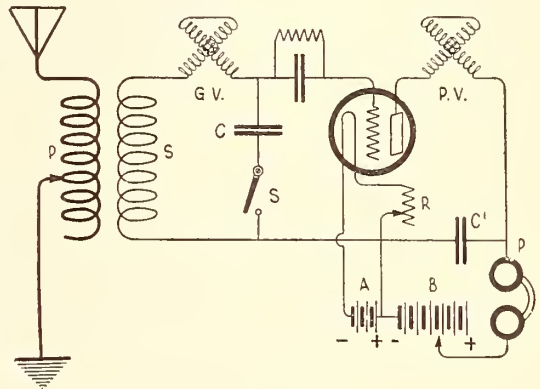

FIG. 2

A small condenser, C, across the secondary of the variocoupler and the grid variometer will also raise the wavelength of the secondary circuit

length worth investigating by enthusiasts mastering the code. The condenser is most easily made from a standard .005 grid condenser (minus the leak), by unrolling and clipping off one half of the copper foil, and firmly rebinding the remaining foil and waxed paper. A switch is again provided for eliminating the condenser on waves which

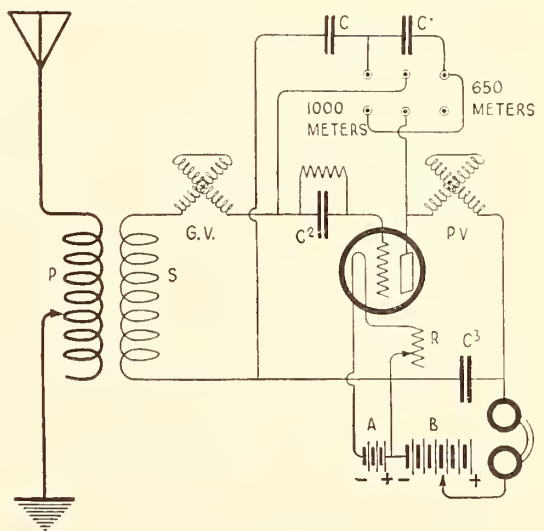

FIG. 3

This system of capacity load permits a wide tuning range—from the amateur wavelengths up to about 1000 meters

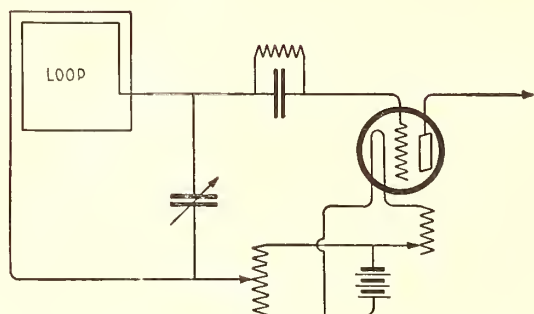

FIG. 4

Here a loop antenna, shunted by a variable condenser, is substituted for the outdoor antenna, ground and variocoupler of the standard receiver

can be received with the variocoupler and variometer alone.

A second system of capacity load, which is used by a well-known manufacturer of variometer receivers, is shown in Fig. 3. This system enables the operator to proceed in overlapping jumps from short waves (up to four hundred and fifty meters) to medium waves (in the neighborhood of six hundred), and high waves (up to one thousand meters), by the three different positions (right, open, and left) of a double-pole double-throw switch. The extra capacities, C and C', may be made in the same manner as that for the circuit shown in Fig. 2, except that only one third of the foil is cut from the standard condenser. This is due to the fact that on medium waves, the condensers are in series, which gives a total extra capacity across the variometer and secondary, of one half that of a single condenser. On the thousand meter adjustment, the capacity (one condenser) is increased across the grid circuit, while the remaining condenser couples the grid and plate elements of the tube, maintaining regeneration by capacity feed-back over the entire scale of wavelengths.

Using an aerial of generous proportions, it is seldom necessary to load the primary circuit. However, if following the instructions given in the preceding paragraphs avails little improvement on the higher waves, a small load (about ten turns of wire on a three-wave tube) should be placed in series with the antenna, and provided with the usual short-circuiting switch.

Some readers have found it difficult to receive the higher wavelengths on the set described by Mr. Seager in the March RADIO BROADCAST. This difficulty is very easily remedied by adding eight turns of wire to the primary, and ten turns to the secondary, adding the wire in each case between the last two high-wave taps. That is, if at present there are twelve turns of wire between the last two (on the high end) primary taps, there will be twenty turns after the addition of the extra inductance. If the set does not oscillate with the additional turns in the circuit, it will be necessary to shunt the tickler with a small condenser (similar to that described for use in Fig. 2) with a switch for disconnecting it.

#### SUBSTITUTING LOOPS ON STANDARD RECEIVERS

*I was much interested in Mr. Herts's article on adding two steps to an Aeriola Sr., in the May number of RADIO BROADCAST. Mr. Herts said that he used a loop on this set. In common with your other numerous readers, I should be obliged if you would show Mr. Herts's book-up using a loop.*

J. W. T. P., TRURO, NOVA SCOTIA.

ANY circuit operating from an open antenna can be successfully converted for loop reception providing that the nearness of broadcasting stations or the presence of radio-frequency amplification justifies the change. It will merely be necessary to rearrange the grid circuit, eliminating the original tuning apparatus, and replace it by the loop with a shunted condenser, as per the diagram in Fig. 4. The notable exception to this procedure is the tickler regenerative circuit, which is not well adapted to loop reception due to the necessity of introducing, in series with the loop, a separate load with a tickler, thus cutting down the number of turns active in the picking up of radio signals.

In the circuit to which J. W. T. P. refers, the loop will be substituted for the first variometer, and the series condenser placed in shunt with it—in other words, as shown in Fig. 4.

#### ANTENNA CORROSION AND RESISTANCE

*I have read that an aerial should be re-wired every year or so, due to the fact that the surface corrodes, increasing its resistance to high-frequency radio currents which I am also informed travel on the surface of the wire. (Why is this?) My antenna has been up nine months, and the signals of late seem weaker than usual. Do you think that it is due to surface corrosion?*

M. A. C., ALBANY, N. Y.

LOSS of signal strength in the above case is doubtless due to some cause other than that which the writer suggests. It is, however, quite possible that corrosion or oxidization at unsoldered joints, if such exist in his antenna, has become so far advanced as to almost cut off or completely isolate certain portions of his aerial system. The decrease in loudness due to surface variations of the wire is seldom sufficient to be noticeable. Before this stage is reached, the wire generally weakens in one or more places and breaks. The voltage drop which our communicant suggests is due to resistance (as are practically all electrical and mechanical losses), and the loss is at all times proportional to the strength of the current. As the received energy is minute to the extreme, it follows that the current would not be sufficiently strong to occasion a perceptible loss.

High-frequency currents, such as radio oscillations, tend to travel on the surface of the wire due to a phenomenon known as "surface" or "skin effect", the study of which takes one quite deeply, but interestingly, into the science of high-frequency alternating currents.

The path or wire of all electric currents is surrounded by a magnetic field which varies in intensity as the current strengthens or weakens. When the amperage (measure of current) rises, the magnetic field spreads out farther from the wire—when it drops, the magnetic field contracts. In alternating electricity the strength of the current is constantly varying from zero to maximum. Hence it goes without saying that the resulting magnetic field is continually jumping in and out from the wire, totally disappearing into the centre of the wire from which it apparently springs, when the current is at zero.

Whenever a moving magnetic field, such as that expanding and contracting about a wire carrying alternating current, cuts another conductor, electricity, or a current, is "induced" therein. This is merely the theory of the dynamo which is nothing more than a machine for cutting a conductor by a magnetic field.

The current induced in a conductor by a near-by alternating current is in a direction *always opposite to that of the*





## Just pick out the size you want

**C**ELORON Radio Panels, ready-cut in standard sizes, save you the trouble and delay of having your panel cut to order. Just go to a nearby radio dealer who sells Celoron panels and pick out the size you want. Then you are sure of getting a panel that is neatly trimmed and finished, and something more—you get the necessary insulation for successful receiving.

Condensite Celoron has high dielectric strength and great insulation resistance. Its moisture-repelling properties prevent warping.

### Easy to work

You will like the "workability" of Celoron panels. They are easy to drill, tap, saw, and mill, and will engrave evenly without feathering. Each panel is wrapped in glassine paper to protect the surface. On

every one are complete instructions for working and finishing.

One of these standard sizes will fit the set you intend to build:

- |                          |                            |
|--------------------------|----------------------------|
| 1—6 x 7 x $\frac{1}{8}$  | 4—7 x 18 x $\frac{3}{16}$  |
| 2—7 x 9 x $\frac{1}{8}$  | 5—9 x 14 x $\frac{3}{16}$  |
| 3—7 x 12 x $\frac{1}{8}$ | 6—7 x 21 x $\frac{3}{16}$  |
|                          | 7—12 x 14 x $\frac{3}{16}$ |

If your dealer cannot supply you, ask him to order for you, or write direct to us. Indicate by number the size you want. Celoron is also furnished in full-sized sheets, and we can cut panels in any sizes desired.

### Write for this free booklet

Our booklet, "Tuning in on a New World," contains lists of the leading broadcasting stations in the United States and Canada, an explanation of symbols used in radio diagrams, and several efficient radio hook-ups. It will be sent free, on request.

To radio dealers: Send for special dealer price list showing standard assortments

## Diamond State Fibre Company

BRIDGEPORT

(near Philadelphia)

PENNSYLVANIA

Offices in Principal Cities

In Canada: Diamond State Fibre Company of Canada, Limited, 245 Carlaw Ave., Toronto

★ **CONDENSITE**  
**CELORON**  
STANDARD RADIO PANEL

*original current.* But, as mentioned before, the magnetic lines of force apparently emanate from the infinite dead centre of the wire. It would then follow that, in expanding, they must cut the wire itself, and induce therein a current always opposing the current that induces it! This is precisely what occurs, and in every alternating current line there is a counter electro-motive force that tends to buck or stop the first current. (This is, of course, not the counter E. M. F. (electro-motive force) generally referred to in an inductive circuit.)

In expanding out of the wire, or in contracting back into

the wire, *more lines of force, in a given time, cut the centre and the inside of the wire than cut the surface.* This is necessarily so, because some of the lines never expand so far as the surface. In other words, this counter E. M. F. is greater at the centre of the wire than at its surface, and the surface being the less opposed and freer path, is taken by the current!

This skin effect, however, is only noticeable with high-frequency currents where the field expands and contracts many thousands of times a second, and the "centre position" is practically constant.

## Supplemental List of Broadcasting Stations in the United States

LICENSED FROM JUNE 16 TO JULY 13 INCLUSIVE

CALL SIGNAL	STATION	FREQUENCY (Kilocycles)	WAVE-LENGTH
KFHS	Nelson, Robert Washington, Hutchinson, Kansas . . . . .	1310	229
KFHU	Sateren, M. G., Mayville, N. D. . . . .	1150	261
KFHY	Mc Ewan, R. S., Trinidad, Col. . . . .	1240	242
KFIU	Alaska Elect. Light & Power Co., Juneau, Alaska . . . . .	1330	226
KFIV	Broyles, V. H., Pittsburg, Kansas . . . . .	1250	240
KFIX	Reorganized Church of Jesus Christ, Independence, Kansas . . . . .	1250	240
WCAP	Chesapeake & Potomac Tel. Co., Washington, D. C. . . . .	640	460
WKAD	Looff, Charles E., Providence, R. I. . . . .	1250	240
WRAZ	Radio Shop of Newark, Newark, N. J. . . . .	1290	233
WSAG	Davis, Loren V., St. Petersburg, Fla. . . . .	1230	244
WSAK	Daily News, The, Middleport, Ohio . . . . .	1160	258
WSAN	Allentown Radio Club, Allentown, Pa. . . . .	1310	229
WSAQ	Round Hills Radio Corp., Dartmouth, Mass. . . . .	1070	280
WSAR	Doughty & Welch Elect. Co., Fall River, Mass. . . . .	1180	254
WTAB	Fall River Daily Herald, Fall River, Mass. . . . .	1210	248

### DELETIONS FROM JUNE 1 TO JUNE 30

KDZG . . . . .	San Francisco, Calif.	WGAM . . . . .	Orangeburg, S. C.
KDZX . . . . .	San Francisco, Calif.	WHAE . . . . .	Sioux City, Iowa
KFBD . . . . .	Hanford, Calif.	WHAW . . . . .	Tampa, Fla.
KFBH . . . . .	Marshfield, Ore.	WIAE . . . . .	Vinton, Iowa
KFCB . . . . .	Phoenix, Ariz.	WKAH . . . . .	West Palm Beach, Fla.
KFEB . . . . .	Taft, Calif.	WKAK . . . . .	Okemah, Okla.
KFGB . . . . .	Pueblo, Colo.	WKAL . . . . .	Orange, Texas
KJJ . . . . .	Sunnyvale, Calif.	WKN . . . . .	Memphis, Tenn.
KNI . . . . .	Eureka, Calif.	WLK . . . . .	Indianapolis, Ind.
KNN . . . . .	Los Angeles, Calif.	WMAG . . . . .	Liberal, Kansas
KOA . . . . .	Denver, Colo.	WMAR . . . . .	Waterloo, Iowa
KSL . . . . .	San Francisco, Calif.	WMAX . . . . .	Ann Arbor, Mich.
WAAL . . . . .	Minneapolis, Minn.	WOAS . . . . .	Middletown, Conn.
WAAY . . . . .	Youngstown, Ohio	WOAU . . . . .	Evansville, Ill.
WCAB . . . . .	Newburgh, N. Y.	WOU . . . . .	Omaha, Neb.
WCAC . . . . .	Fort Smith, Ark.	WPAA . . . . .	Wahoo, Neb.
WCAW . . . . .	Quincy, Ill.	WPAY . . . . .	Bangor, Maine
WCN . . . . .	Worcester, Mass.	WPE . . . . .	Independence, Mo.
WEAV . . . . .	Rushville, Neb.	WPO . . . . .	Memphis, Tenn.
WEAX . . . . .	Little Rock, Ark.	WRAC . . . . .	Mayville, N. D.
WEH . . . . .	Tulsa, Okla.	WRAC . . . . .	Escanaba, Mich.
WEY . . . . .	Wichita, Kansas	WRAM . . . . .	Galesburg, Ill.
WFAC . . . . .	Superior, Wis.	WSAV . . . . .	Houston, Tex.
WFAW . . . . .	Miami, Fla.	WWAY . . . . .	Chicago, Ill.
WFAZ . . . . .	Charleston, S. C.		



"Roxie's" Own Story

# RADIO BROADCAST

Four Complete "How To Make It" Articles

A Broadcasting Service

From Your Lamp Socket

With MacMillan in the Arctic

Choosing the Proper Rheostats

for the

Tubes

You Use



25  
Cents

October, 1923

Published by

DOUBLEDAY, PAGE & CO.

Garden City, N. Y.

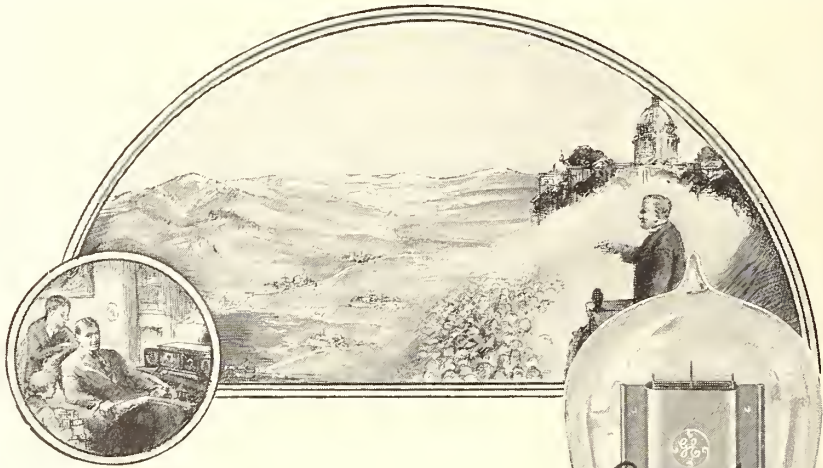

## Carries Great Messages Around the World

**T**HAT statement adequately expresses what is perhaps the greatest influence of radio in developing and bettering human fraternal interest, not only between people of one community, of one country, of one state, or even a single nation, but between all nations and all peoples of the world.

Be these messages from government leaders—from the heads of the world's greatest educational institutions or from those who stand foremost in the arts of the world—they will serve to bring the human race into closer contact.

In the past ages great orators and writers, famous poets and musicians have swayed the destinies of nations, and have been instrumental in the rise and downfall of mighty empires.

In the future these same influences of similar great minds will, through radio, create a better understanding and a greater fraternal spirit between the people of the nations.

It is the vacuum tube that has made possible this broad and far reaching application of radio telephony, and that plays the most important part in the operation of your receiving set.

Cunningham Vacuum Tubes, standard for all makes of receiving sets—built by one of the world's largest manufacturers with unlimited resources—are the product of years of manufacturing experience and the genius of the engineers of that great scientific organization, the Research Laboratory of the General Electric Company.

### Cunningham Radio Tubes

- C-301A—6 Volts ¼ amp. Amplifier . . . . . \$6.50
- C-299—3 Volts .06 amp. Dry Battery Det. & Amp. . . . . 6.50
- C-300—6 Volts Gas Cont. Detector . . . . . 5.00
- C-11—1.1 Volts .25 amp. Dry Battery Det. and Amp. Special Base . . . 6.50
- C-12—Similar to C-11 with standard base . . . 6.50

### Patent Notice:

*Cunningham tubes are covered by patents dated 11-7-05, 1-15-07, 2-18-08, and others issued and pending. Licensed for amateur, experimental, and entertainment use in radio communications. Any other use will be an infringement.*



## CUNNINGHAM National Tube Week

September 24 to  
October 1, 1923

**\$5000 in Cash Prizes  
to Radio Dealers**

*E. J. Cunningham Inc.*

Home Office:  
248 First Street  
San Francisco, Calif.

154 West Lake Street  
Chicago, Illinois

30 Church Street  
New York City, N. Y.

★ Tested and approved by RADIO BROADCAST ★



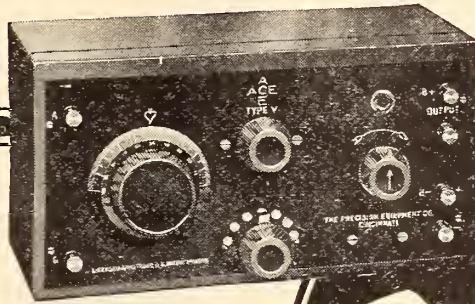

Licensed under  
Armstrong U. S. Patent  
No. 1,113,149



## A Highly Efficient Set at a Moderate Price

Here is an inexpensive set that receives signals clear and distinct. It is a long range regenerative, radio receiver and under ordinary conditions stations from coast to coast are heard. We have many letters from owners praising the efficiency of the Ace Type V.

The low cost of this set in addition to its remarkable simplicity of operation increases its popularity among radio fans day by day.

A loud speaker can be operated in connection with the Ace Type V by adding an Ace Type 2 B, a new two-stage Audio Frequency Amplifier, which sells for \$20.00. With this addition, music or voice can be heard distinctly all over the room or house.

The modest price of this set makes it possible for everyone to enjoy radio. Don't be without radio entertainment any longer—get an Ace Type V and listen to the world's best musical concerts.

### The Precision Equipment Company

Powel Crosley Jr., PRES.

1020 Vandalia Avenue, Cincinnati, Ohio

*Armstrong  
Regenerative  
Receiver*



If your dealer cannot supply you, order direct, mentioning his name. Ask for "Simplicity of Radio." Your copy is *Free*.

DEALERS: Write on your letterhead for attractive sales proposition.

# Radio Broadcast

ARTHUR H. LYNCH, EDITOR



## CONTENTS FOR OCTOBER, 1923

<i>Major-General George O. Squier</i> - - - - -	<i>Frontispiece</i>
THE MARCH OF RADIO - - - - -	J. H. M. 447
A BIT ABOUT MYSELF - - - - -	("Roxie") S. L. ROTHAFEL 458
GIVING THE PUBLIC A LIGHT-SOCKET BROADCASTING SERVICE	
	WILLIAM HARRIS, JR. 465
WHEN THE BUG BIT IN SAMOA - - - - -	QUINCY F. ROBERTS 471
IN THE WAKE OF THE CONTEST WINNERS - - - - -	477
A Better Broadcast Receiver - - - - -	(Honorable Mention) ARTHUR L. MUNZIG 477
A Set You'll Like To Make - - - - -	(Honorable Mention) FRANK NELEM 480
A Set With a Tuned R. F. Amplifier - - - - -	(Honorable Mention) J. W. DENNING 484
A Home-Made Three-Tube Outfit - - - - -	(Honorable Mention) L. REITH 486
Summary of Receiving Contest Entries - - - - -	489
A NEW STATION AT WASHINGTON, D. C. - - - - -	PIERRE BOUCHERON 494
RHEOSTATS FOR THE TUBES YOU USE - - - - -	ZEH BOUCK 496
WITH MACMILLAN AND RADIO, NORTH OF CIVILIZATION	
	E. F. McDONALD, JR. 500
WHAT BALLOON RACERS DID WITH RECEIVING SETS - - - - -	507
WHAT YOU SHOULD KNOW ABOUT CONDENSERS, II	ALLEN D. CARDWELL 510
TRUE PIANO MUSIC FROM A NEW MICROPHONE - - - - -	516
WHAT OUR READERS WRITE US - - - - -	517
IN THE R. B. LAB. - - - - -	520
ADDITIONAL BROADCASTING STATIONS IN THE UNITED STATES - - -	523
NEW EQUIPMENT - - - - -	524
THE GRID—Questions and Answers - - - - -	526
AMONG OUR AUTHORS - - - - -	534

Copyright, 1923, by Doubleday, Page & Co. All rights reserved  
TERMS: \$3.00 a year; single copies 25 cents

F. N. DOUBLEDAY, Pres.

RUSSELL DOUBLEDAY, Sec'y.

ARTHUR W. PAGE, Vice-Pres.

S. A. EVERITT, Treas.

NELSON DOUBLEDAY, Vice-Pres.

JOHN J. HESSIAN, Asst. Treas.

## DOUBLEDAY, PAGE & CO.

THE WORLD'S WORK  
CHICAGO: People's Gas Bldg.

COUNTRY LIFE

THE GARDEN MAGAZINE

SHORT STORIES

EDUCATIONAL REVIEW

GARDEN CITY, N. Y.

NEW YORK: 120 W. 32nd Street

BOSTON: Tremont Bldg.

LOS ANGELES: Van Nuys Bldg.



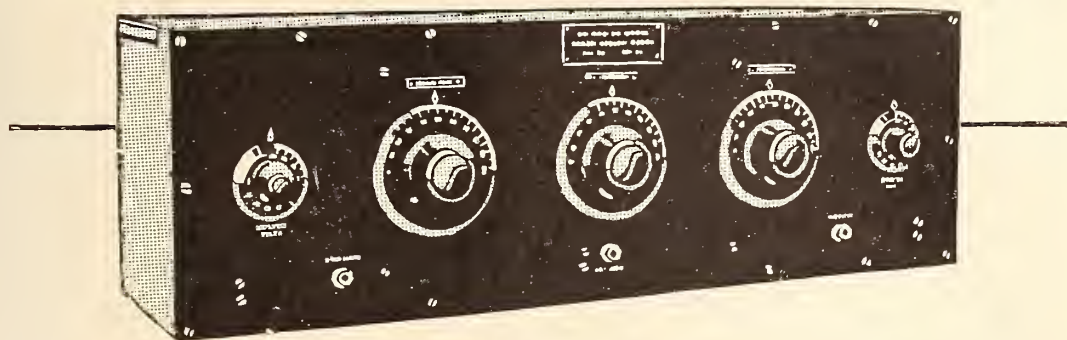

**FORMICA**



is used in the new  
**FREED-EISEMANN**  
*N R Neutrodyne\* Receiver*

**T**HE panels of the new Freed-Eisemann Neutrodyne Receiver are Formica. This is natural because Freed-Eisemann have long been consistent users of Formica in all their past radio products.

It is the endorsement of leading radio concerns of this caliber from one end of the country to the other that makes Formica so staple and desirable a product for the radio dealer to handle. Amateurs know and want it.

Formica panels may be had promptly in *any desired size*. It isn't necessary to take a size that some one else wants to sell.

**THE FORMICA INSULATION COMPANY**  
 4628 Spring Grove Avenue Cincinnati, Ohio

*Sales Offices*

50 Church St. New York, N. Y.  
 422 First Ave. Pittsburgh, Pa.  
 1042 Granite Bldg., Rochester, N. Y.  
 415 Ohio Bldg. Toledo, Ohio

1210 Arch St. Philadelphia, Pa.  
 1819 Lyndale Ave., S. Minneapolis, Minn.  
 Sheldon Bldg. San Francisco, California  
 Whitney Central Bldg. New Orleans

414 Finance Bldg., Cleveland, Ohio  
 9 S. Clinton St. Chicago, Ill.  
 313 Title Bldg. Baltimore, Md.  
 47 King St. Toronto, Ontario

Reg. U. S. Pat. Off.

**FORMICA**  
 Made from Anhydrous Redmanol Resins  
**SHEETS TUBES RODS**

★ Tested and approved by RADIO BROADCAST ★



MAJOR-GENERAL GEORGE OWEN SQUIER

Chief Signal Officer of the U. S. Army, whose experiments in "wired wireless" have made possible a practicable, paying service which will furnish "subscribers" with news, entertainment, and educational matter. Such a service is already being successfully operated on Staten Island, N. Y. (See page 465)



# RADIO BROADCAST

Vol. 3 No. 6



October, 1923

## The March of Radio

### OCEAN TO OCEAN BROADCASTING

**A**LTHOUGH it is not to be expected that developments in radio will rush to greet us every month (for it is bound to happen, now and then, that radio, like any other development, marks time), nevertheless several of the events which came to our attention during the past month do indicate the orderly progress of the art. Especially is this the case with the plans made for the rôle which radio was to play on the night when our late President was scheduled to address, personally, an audience in the Civic Auditorium in San Francisco, and, by land lines and radio, another audience "measured in the millions." We get so used nowadays to hearing of radio audiences measured in millions, that such an announcement scarcely arouses interest; but in this case it should, because this prospective audience undoubtedly was of this size. It is so easy to say that at least one person out of a hundred in our country *must* be listening in on a radio set, and that, inasmuch as there are a hundred million people in the land, the audience must be a million!

It is extremely doubtful if an audience of a million persons had ever been possible before this demonstration was arranged. The audience which would have listened to the President, had not his fatal illness prevented it, was not to have been the clientèle of one station—there were to have been *six* broadcasting stations, from Coast to Coast, actuated simultaneously by the President's voice. To think of a low, well-modulated voice being thrown out into the air

at such strategic points that it is heard at the same instant over the whole land—one man quietly addressing, intelligibly, a million of his fellows! In the olden days it required no such feat as that to be classed as a miracle.

If this plan had gone through, a peculiar effect might have been observed by an experimenter located somewhere about the middle of our country. The transcontinental telephone line, over which the voice currents were to travel to actuate the stations on the Eastern Coast, is partly of the "loaded type." To keep the voice currents from being wasted to an excessive degree as they take their long journey it is necessary to put iron-cored coils in series with the wires at regular intervals—every few miles for overhead lines and every mile for cables. The electric current travels over such a loaded line less rapidly than it does over a pair of ordinary overhead wires. For two copper wires, supported on poles by good insulators, the speed of the signal is practically the same as that of light—186,000 miles a second. In the loaded line, however, the coils slow down the current to the extent that it takes about one-fifteenth of a second for the signal to travel from San Francisco to New York. If, then, a listener with a good set, located about half way between these two points, should be able to tune in on a West Coast station at the same time as he did on an East Coast station, that voice from the East would arrive in his ears one fifteenth of a second later than that from the West: the voice

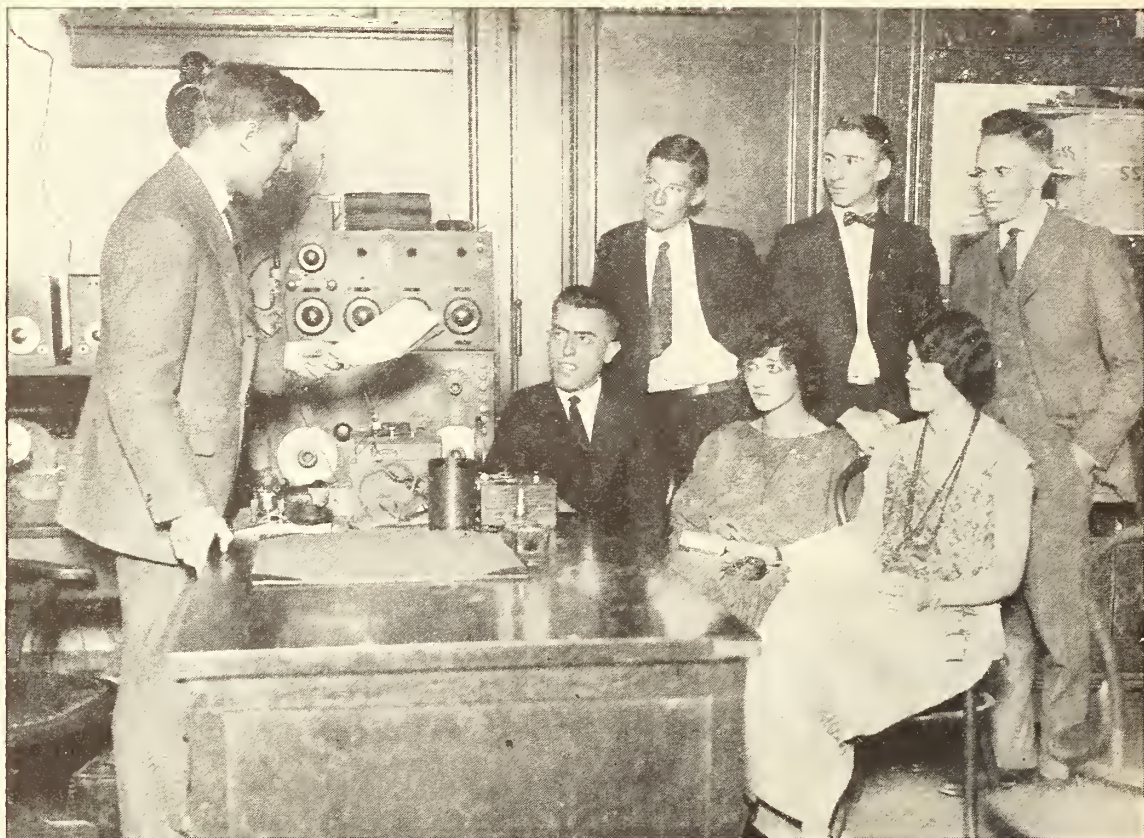

#### LAYING DOWN THE LAW TO PROSPECTIVE AMATEUR OPERATORS

When the successful applicant in New York passes his test for an operator's license, he is given a talk by J. W. Swanson, Radio Inspector, who is seen at the left. The incipient ham is asked not to transmit during broadcasting hours, be on the alert for SOS signals, and generally maintain the best traditions of the amateur

from the New York station would sound like an echo from the San Francisco station. Since the test was not carried out, however, no one had the opportunity of hearing such a phenomenon.

#### The Telephone Company's Part in This Work

IT IS interesting to us that our guess as to the reasonable and probable development in radio broadcasting is so quickly being vindicated. That the development and execution of this new form of communication would undoubtedly be carried out by the great research and engineering staffs of our nation-wide communication organization—The American Telephone and Telegraph Company—seemed to us the only logical possibility. This company has spent a tremendous amount of money in training its research staff and in accumulating information essential in the field of speech transmission. Any other organization would

necessarily have to incur similar expense to be on an equal footing in the game, and even if this uneconomical step should be decided upon it would still be a long way behind the Telephone Company in the race for new and better accomplishment.

It seems assured that radio broadcasting must necessarily be completely interlinked with the wire network covering our country; we cannot conceive of it growing independently here and there over the land, in isolated spots. This is not the way it will really develop into a country-wide service. No matter how good the isolated stations may be they must still play a minor rôle in the tremendous field which radio is destined to fill.

It is a very good thing for the art that there are so many excellent stations operating independently of the Telephone Company; competition makes for greater progress and stimulates the engineers and managers to produce better and better programs, all of which ben-



efits the listening public. These independent stations cannot perform the same service, however, as a network of stations, scattered all over the country and interconnected for operation by the same voice. It is this possibility that gives to radio broadcasting its great potential value and importance; the Chief Executive addressing the country is no longer a dream, it can be accomplished to-day.

By using part of their transcontinental, high-quality, telephone line, the telephone engineers were ready to deliver, the President's voice all the way across the country with imperceptible distortion. At San Francisco, Omaha, Chicago, New York, and Round Hill, the modulators of the radio stations were regulated to function as well as though the speaker were personally in the studio. Three thousand five hundred miles of telephone line were to be tied up in the demonstration, a fact which shows at once how it is that radio broadcasting must become an integral part of the rest of the country's communication scheme.

### Simplified Receiving Sets

**D**URING the past year, nearly every issue of a radio journal or newspaper has brought glad tidings of a new and more efficient receiving circuit. We long ago stopped trying to keep a record of these supposedly novel ways of using a vacuum-tube detector, because it seems that in the end, after all the required refinements are made, they amount to about the same thing. Experts tell us that it makes but little difference what circuit is used—that if sufficient skill and intelligence are displayed in properly proportioning the various parts, practically the same results can be obtained with any of the recommended circuits. This seems a logical conclusion to one understanding the principle of the vacuum tube, yet many times the enthusiast solemnly declares one circuit is incomparably better than the one he has been using (and which he recommended to us only a few days before) and which we haven't yet had time properly to try out. We have one ac-

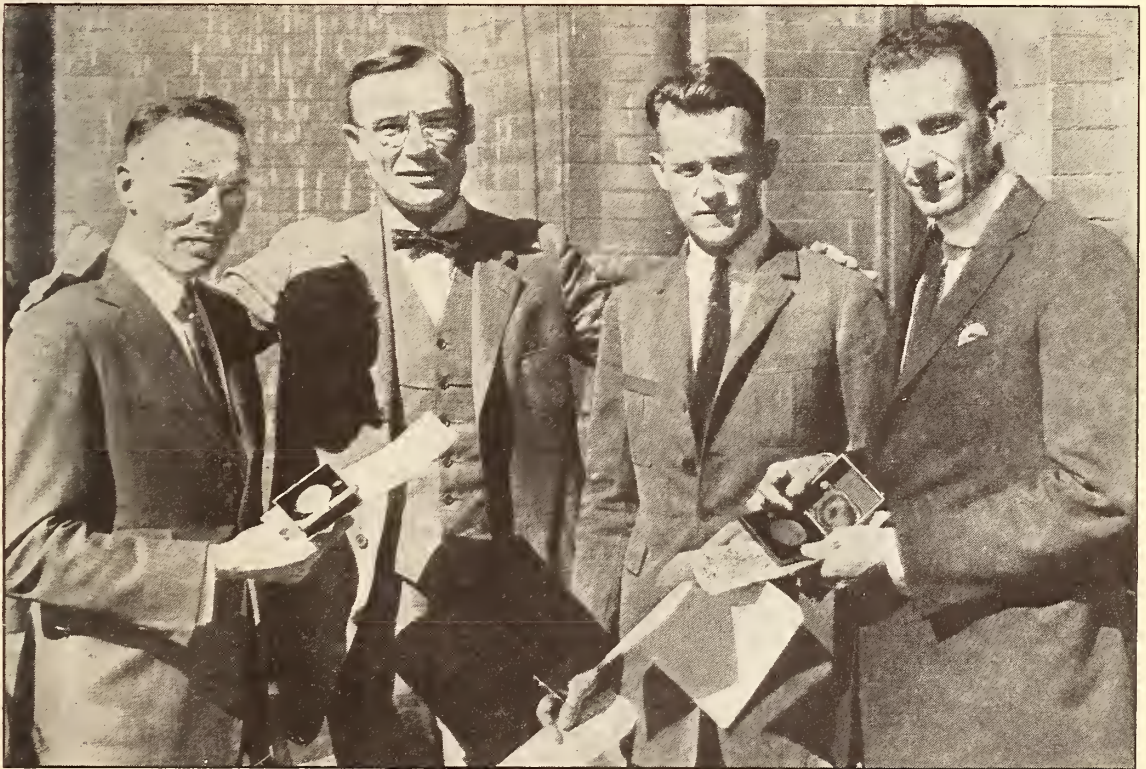

THE FIRST THREE HEROES TO RECEIVE THE RADIO MEDAL

The award of this medal is restricted to wireless operators, and the first three were presented to the three operators of the *City of Honolulu* which burned and sank in the Pacific last spring. Mayor Cryer of Los Angeles made the presentation for the Radio Corporation of America. Left to right: N. C. Kumler, Mayor Cryer, Walter P. Bell (Chief Operator), and H. D. Hancock



quaintance whom we have dubbed the "circuit shark." He can draw out at any time practically any circuit which has been shown to him; it seems as though his brain must be filled with short circuits with all those connection schemes loaded one on top of the other. His last circuit is always the best. Probably all of you number someone like him among your acquaintances.

However much various circuits of the same general kind measure up to one another as regards their sensitiveness, it is a fact that one particular circuit may be much superior to another in the ease with which the requisite adjustments can be carried out. In this we see a great chance for improvement in the future receiver; surely the one-dial receiver is bound to come. The average non-technical man cannot be expected to acquire the skill demanded by the very sensitive sets, requiring the simultaneous adjustment of perhaps four dials, condensers, coils, filament current, coupling, regeneration, and what not. Many people don't care for the tinkering part of the job; they want the sets for

the programs they bring in. For such listeners, the manipulation of the set should be the simplest possible. The popular Westinghouse RC receiver was a good attempt to simplify the adjustments required with a regenerative set but this still leaves much to be desired. It requires considerable skill to get the best results, and furthermore has the bad feature of re-radiation from the antenna.

As we look at the various good sets available to-day it seems that the difficulty of proper adjustment is a necessary result of trying to get the very best results out of each tube in the set—naturally a very desirable condition. But, if much can be gained in simplicity by sacrificing some of the sensitiveness of the tubes, it should be worth while. As the present tubes use so little power for the filament and plate, the increase in upkeep of a set having, say, two more tubes than the present sets, would not be great. It seems to us that a set having radio- and audio-frequency amplification, without regeneration, must be possible in such a design that the only



RADIO CONCERTS IN PLACE OF PUBLIC BANDS IN PARIS

Here is a crowd gathered about one of the old band stands on the Champs Élysées, listening to music from the Eiffel Tower station just across the river





THE PROGRAM DOESN'T SEEM TO AGREE WITH CURLY HAIR

All the other "members of the radio audience," however, seem gravely attentive to the output of the receiver with which they are being entertained in Central Park, New York

adjustment required is the one dial tuning the antenna circuit—the antenna being a loop. A good loop antenna is sufficiently selective, both because of low resistance and directive qualities, to tune out ordinary interference, and such an antenna with three steps of untuned radio-frequency amplification with two steps of audio-frequency amplification should be sufficiently sensitive to bring in any station within reasonable distance.

If such a set is not practicable, then a super-heterodyne outfit should be possible which with about seven tubes would give all the volume and all the selectivity desired. Such a set is feasible with only one adjusting dial, and although the first investment for tubes would be high, it seems that it would be worth while for the average radio customer to-day. To do away with the tinkering—simply to turn one handle to a definite, marked point and get the station wanted, if it is transmitting—that is the kind of a set which will probably find a good deal of favor in the future.

### The Size of Radio Audiences

**I**N TWO circulars emanating from the news bureau of the General Electric Company, there is given some interesting information which illustrates the optimism of the broadcasting station manager—information which enables us to picture quite well the distribution of the radio audience of such a powerful station as WGY, Schenectady, N. Y.

In the first circular we learn that WGY has received in all 65,000 letters from its enthusiastic listeners, since the inauguration of broadcasting activities sixteen months ago. These letters come from points as widely separated as Hawaii and England and as Vancouver and Valparaiso. With such landmarks to delineate his nightly audience, it is no wonder the manager counts his listeners by the million.

We learn that "there are at least 2,000,000 radio sets in the country and of that number 1,500,000 are almost nightly within range of





PEOPLE SIX MILES AWAY OBJECTED TO THIS LOUD SPEAKER

Programs were sent out on sound waves from this tower over the whole countryside by Colonel Edward H. R. Green, son of the late Hetty Green, of South Dartmouth, Mass. Residents over in Nonquitt were not so keen as was the Colonel, however, for this unusual volume of sound, and accordingly the concerts were discontinued

WGY." Even with no further data to establish a judgment, one would be entitled to the conclusion that in Schenectady some optimism-giving fluid must still be obtainable; and in the other circular a very interesting bit of information is contained in these words: "After a recent minstrel show broadcast by WGY, 1400 letters were received by the station within 24 hours. Over 2000 letters were received within a week, referring to this particular entertainment." Now these two sentences furnish us with apparently reliable data as to the distribution of WGY's audience, and incidentally that of any similar station.

As no mail collections are made late in the evening (after the radio concert) all of these 1400 letters must have started on their way to WGY's manager the next morning,—and they all reached him that same day, *after a necessarily short journey!* It would appear that they could not have travelled more than perhaps 200 miles if they were to be delivered in Schenectady the same day, so it seems reasonable to believe that 70 per cent. of the audience of WGY, one

of our most powerful stations, is not more than about 100 miles away from the station. In view of the first statement quoted, this would lead one to believe that of the "2,000,000 sets in the country," 1,500,000 of them are in the vicinity of Schenectady. We are willing to admit the attractiveness of certain parts of this country town, but surely the radio station's manager is over-enthusiastic about it when he puts about half the country's radio listeners within a short day's journey of his city. Well—such optimism is what makes the news look attractive.

De Forest Company Beaten by the Westinghouse Company

**A**BOUT ten years ago, Armstrong was granted the patent on vacuum-tube operation which was destined to play an important part in the commercial development of radio in the coming decade. Many of us didn't then appreciate the commercial possibility of the patent—in fact it would have taken a man with a super-imagination to pic-



ture, then, the radio development which was to take place during that span of years. From five thousand sets to five million—that simple comparison gives very nearly the relative numbers of radio listeners, and of course also indicates the increase in the value of such a patent as Armstrong was granted. Roughly speaking, this fundamental patent, which has been interpreted by the Courts to cover any scheme which makes possible the transfer of the B battery energy back into the grid circuit, has thus increased in value a thousand fold during the less than ten years of its life.

In the early days of the patent, of course, broadcasting was unknown as we have it today, and practically the whole value of the patent lay in the possibility of selling regenerative sets to the radio amateur; but the radio amateur, it developed, isn't a very good customer for complete sets, because, after he knows how, he generally prefers to build his own. Because of this situation Armstrong was not then able to realize much on his idea. Seventeen companies did agree to make regenerative sets under a license granted them by Armstrong for a nominal fee, his returns to be had from royalties on the sales of the manufacturing companies.

These licenses were rather restricted in that they limited the activities of the manufacturing

companies to making and selling sets for amateurs, experimenters, and scientific schools—moreover the licenses were not transferable. In those days, De Forest probably did not appreciate the value and uniqueness of Armstrong's patent. Apparently he thought he could do as well himself in the patent office, so he did not consider it worth while to take out a license. His attitude is perfectly easy to understand—a pioneer of his standing, having undoubted right to the audion patents, applying to a young student for permission to use his own device in a circuit very similar to that he had always used, and to pay money to the young student, who had frequently publicly challenged De Forest's understanding of the action of the audion, for permission to put an extra coil or condenser in his circuits—this must have seemed out of the question to the inventor of the audion, and he didn't do it.

As a result, a few years later he found his company rather embarrassed in the competition for the radio-receiver market. People wanted a regenerative set because the technical press told them this was the only reasonable set to purchase. As the patent had in the meantime been acquired by the Westinghouse Company for a goodly sum, he found that the valuation placed on a license had gone up by leaps and bounds so that it seemed now not a question of pride, but



THE RADIO CORPORATION'S NEW MESSAGE CENTRE AT 64 BROAD STREET, NEW YORK

In this room, messages are exchanged at high speed between America and France, Norway, Germany, and Great Britain via the great transmitting station at Rocky Point, L. I. and the receiving station at Riverhead, L. I. The wavelengths used are from 10,000 to 20,000 meters



ANOTHER RECORD FOR THE "LEVIATHAN"

Chief Radio Officer Pickerill and his assistant, A. C. Tamburino, are holding some of the 4000 messages sent and received during the vessel's first trip to Europe and back since her reconditioning

### The *Leviathan* Breaks Some Records

ACCORDING to an announcement of the Western Electric Company, the radio apparatus installed on our largest liner has set a new mark for merchant-marine radio. The ship not only broke all previous communication records by transmitting 15,000 words a day, to and from shore, but managed to keep in constant touch with land radio stations from one thousand to thirteen hundred miles away. By means of new apparatus specially designed for it, the *Leviathan* operated simultaneously, for long periods of time, two different sending and receiving sets. The steamship carries four antennas,

two for sending and two for receiving.

### A Radio Blind Spot

rather of finances, in acquiring a license. Again he didn't do it. A possible loophole was, however, still left to him—to absorb one of the small concerns which had obtained a patent license and thus market his wares through a properly licensed company. This was apparently done, and various other methods of making the best of a rather disadvantageous situation were subsequently attempted.

Under a decree recently issued, the U. S. District Court of New Jersey decided the case against the De Forest Company and the Radio Craft, Incorporated (the small company which, although retaining its name, had been essentially absorbed by the De Forest Company). The verdict of the Court was in favor of the owner of the patent, the Westinghouse Electric and Manufacturing Co.

The Court's decision also contained a warning for those unlicensed companies which have been putting out non-regenerative receivers so built that they might readily be changed into the regenerative type by the addition of a simple connection, or by a similar subterfuge. This perfectly just and proper decision of the Court emphasizes the advantage which the Westinghouse Company acquired in purchasing patent No. 1,113,149.

FROM far-away Oregon comes an interesting letter telling of experiments being carried out in the mountainous region of that state to find out definitely some of radio's reputed aversion for certain locations. Station KFAY is located in Medford, among the mountains of southwest Oregon. Its signals are heard as far away as Montana, to reach which they must travel right across the state. Directly in their path is the town of Prospect, only forty miles away from Medford—and yet the station is never heard in Prospect. The waves apparently jump right over Prospect in their haste to reach Montana! Tests at points around the "dead spot" seem to show it to be very definitely limited. At a point twelve miles past the dead zone the signals come in strong and clear. The question of bad grounds at one point and good grounds at others, has been taken up in the experiments.

We are gradually learning that such things really do exist, and many of our readers have probably experienced much difficulty in getting certain stations while other stations,



not so powerful, or more distant, come in with plenty of volume. It is worth while, therefore, to record such a phenomenon, when it is vouched for by the careful experimenters of KFAY, who sent us the account of the tests.

We mentioned quite some time ago that very careful measurements by radio engineers showed that the radiation from WEAJ was only one twentieth as strong in a certain direction as it was in others; that there was a kind of radio hole, actually mapped and measured quantitatively, for which the probable cause seemed to be the absorption of the signal by the steel structures of Manhattan. Of course, no such cause as this can be ascribed to the Medford station, as the skyscrapers haven't yet arrived in that city. It may be that there is a very large ore body around Medford playing pranks with the waves.

A knowledge of radio "blind spots" is well worth gaining; if the region is sufficiently important (as it is in the case of WEAJ) a small station could be located near the dead region and operated from the main station by land wires, thus giving local radiation to "fill up the hole."

Incidentally, the map of the country surrounding the station at Medford (sent to show the kind of country in which the effect occurred) is incorporated in a circular setting forth the attractions of southeast Oregon. Looking the circular over made us quite forget the trouble with radio waves, and regret that our vacation trip was already over. If these words happen to come to the attention of the Chamber of Commerce of Medford, they may feel assured of having procured at least one visitor in the near future, because, if they really have such fishing as the circular boasts, we shall probably bring our camping outfit along and stay in that exceedingly attractive region for quite some time.



CORNELIUS COLE, 101, AND RICHARD HEADRICK, 6, AT KHJ

### A Man Who Knew Lincoln

**P**RECEDING the hordes of strong men who swept across the western plains in the gold rush of '49 came Cornelius Cole. He found something more precious than gold in California—the joy of service to this country and to humanity.

The aged statesman and centenarian—he celebrates his 101st birthday in September—was a United States senator and a confrère of Abraham Lincoln in the dismal days of the Civil War. He was born on September 17, 1822, during the administration of President Monroe.

On July 3rd last, he sat in the studio of the Los Angeles *Times'* radio station, with little Richard Headrick, film actor and violin prodigy, 6 years of age, on his knee, and gave a graphic recital of his personal recollections of Lincoln. His words from a Los Angeles radio station, personally commemorative of President Lincoln, and his description of the law abolishing slavery, in which he took an active part,



© Underwood &amp; Underwood

#### IN THE CRYSTAL STUDIO AT WJAZ

Guests at the Edgewater Beach Hotel, Chicago, can see the performers in the broadcasting studio through plate glass windows which are three-ply and hence absolutely sound-proof. The microphone is concealed under the lamp at the left of the picture

were a privilege which probably will never again be had. July 3rd was an anniversary of the Battle of Gettysburg and Mr. Cole told the radio listeners of his feelings as he sat on the platform a few feet from the Great Emancipator while the latter was sounding the phrases of his immortal Gettysburg address.

The sight of the venerable pioneer with the youthful "star" on his knee was something never to be forgotten by the guests in the studio.

#### New Super-Cable

SOME time ago we quoted one of the telegraph executives as prophesying that the ocean cable was soon to have certain improvements which would discount the rapid strides transoceanic radio has been making. Although minor improvements are continually

being made in the receiving apparatus used with the ocean cable, little real progress has been made since radio started on its phenomenal advance. Contrary to what many people think, electric currents do not always travel with the speed of light; especially is this true, with the currents passing over the ocean's bottom through the gutta-percha-covered cables guiding them across. An appreciable fraction of a second elapses after the switch is closed in Europe, before the sensitive receiving galvanometer records the arrival of any current in America. Owing to the absorption of the electric charge by the rubber insulation, and a lack of an appreciable magnetic field around the cable, the maximum available speed of transmission is a comparatively few words a minute. The rubber insulation used has much to do with this slowness of travel, but this rubber is required to maintain the high insulation, otherwise the comparatively weak currents would all leak out into the

ocean before going far in the cable. If a stronger magnetic field could be set up around the cable, when it is carrying its signaling current, the speed of signaling might be considerably increased.

According to an announcement of Mr. Carlton, of the Western Union Telegraph Company, such a scheme is now available and is being installed by his company, in a cable which is to reach from the United States to Italy. The engineers of the Western Electric Company's research laboratories have discovered a new alloy which has such magnetic properties that a thin layer of it wound over the rubber insulation will increase the magnetic field around the cable many times, and thus make possible quicker signal transmission. Such a cable was suggested many years ago by a Danish engineer, Krarup, but the proper kind of iron was not then



available to make his idea feasible. The speed of signaling with this new cable will, according to Mr. Carlton, be several times as great as with the older type of cable.

### Is Wired Wireless the Future of Broadcasting?

**WE** HEAR from time to time about the experiments being carried on to show the feasibility of using high-frequency currents, sent over wires, to displace the present broadcasting scheme, in which radiated, as contrasted with guided, high-frequency power is used. This idea is generally credited to Major-General Squier, Chief Signal Officer of the U. S. Army, who carried on extensive experiments with "wired wireless" in Washington, D. C.

The attractive feature about this method of furnishing service is the ease with which revenue could be equitably collected for financing the scheme. The subscriber could pay for the evening's entertainment just as he now pays for the ordinary telephone service. Furthermore, there should be less interference with such a scheme than there is with the present broadcasting scheme. Certainly, such channels of communication as do require radio (ship-to-ship and ship-to-shore traffic), would have available more frequencies than they now have.

It is true that there is a tremendous plant in the form of telephone installations which work but a very small part of the time, so that any other service which can be furnished over the present wire system would be economically desirable—provided of course that it did not interfere with the present necessary service.

Granted however that carrier-current installation does offer possibilities for a new service over the wires—and the account, in this issue of *RADIO BROADCAST*, of the wired Radio Service Company's successful experiments on Staten



THE NEW STAND BUILT FOR THE N. Y. PHILHARMONIC ORCHESTRA  
Willem Von Hoogstratem is shown conducting his orchestra of 106 men, at one of the Stadium concerts in New York. The stand, erected by the General Electric Company, is portable and adapted especially for the broadcasting of the orchestra's programs. The two black dots, one above the other, to the right of the left-hand pillar, are the microphones

Island seems to support this premise—it will be an addition to radio broadcasting, instead of a substitute for it. We have the strongest kind of conviction that radio has become a permanent part of our day's activities and that in the future it will be even more necessary to us than at present. Radio broadcasting reaches many places where there are no wires and probably always will do so. The real service that broadcasting can furnish is a demonstrated fact, and the other service still needs to be proved. For many of us, "tuning-in" on various stations has a fascination which "wired wireless" would lack entirely. It seems probable that in the larger cities, where the telephone system may be suitably adapted to give carrier-current entertainment without unreasonable expense, it will be done, so that subscribers may either tap the wires or tap the ether for their evening's entertainment.

J. H. M.





"ROXIE"

S. L. Rothafel, whose informal and witty announcements during the concerts broadcasted by his Capital Theatre Orchestra and "Gang" have made him very popular among the radio audience. He tells of his past history—from \$2-a-week days and failure in book-agenting to struggles with a country moving-picture theatre and final success in New York





THE "GANG" AND "ROXIE"

Top Row: Left to Right: William Axt ("Dr. Billy"), Carl Scheutze, Helena Marsh, Yascha Bunchuk, Frederick Jagel  
 Middle Row: Eugen Ormandy ("The Blue Blond"), Melanie Dowd, Louise Scheerer, Mme. Elsa Stralia, Editha  
 Fleischer, Bruce Benjamin  
 Lower Row: Edna Baldwick, Nadia Reisenberg, S. L. Rothafel ("Roxie"), "Betsy" Ayres, Evelyn Herbert

## A Bit About Myself

The Story of the Early Struggles, Varied Experiences, and Final Success  
 of a Man Who is Well Known to Thousands Who Listen to the Capitol  
 Theatre Concerts Broadcasted Through W E A F, W C A P and W M A F

By "ROXIE" (S. L. ROTHAFEL)

Presentation Director, Capitol Theatre, New York

**I**N THIS helter-skelter life in which we find ourselves, our minds are likely to focus almost exclusively on the situation of the moment; we are wont to forget, in following the pace of the present and preparing for the immediate future, the varied joys of yesterday. As a rule, the bygone years, in retrospect, are shaded to a great degree by the incomparable brush of Father Time in a manner that blends sadness and happiness into a picture of subdued color and great beauty. The business of to-day renders the thoughts of yesterday a pleasure that most of us can—or at least, do—find little time for, despite the many blessings which a bountiful passing of years has showered upon us.

My friends—and I feel justified in believing that most of you who read these few words

are my friends—the preparation of this sketch makes it possible for me to look over the departed years as they pass in review and are recorded here at my pen-point. This form of indoor sport is rarely my lot, and before I began it struck me as just another obstacle to overcome; but as the words form beneath my hand the pleasure of the writing increases. I trust that you, too, will find it increasingly interesting.

It is quite unlikely that any day in my life was or will be as important as July 9, 1882—that was my birthday and necessarily marks the beginning of my career (18 years to 1900, plus 23—total 41. Right!). Whether I was a good baby or not is a subject for discussion, for I have heard varying reports and must admit that my memory is not keen enough for





WILLIAM AXT

Known to those who have heard "Roxie" introduce him, as "Dr. Billy"

me to vouch for the authenticity of any of them. My birthplace was Stillwater, Minnesota, a hamlet made famous in song and story by some sage who attributed to it the quality of running deep.

As a youngster, I was like most others of the day and of the environs of Stillwater—given to a certain amount of mischief. An occasional broken window as the result of an improperly aimed bit of snowball or the report of a bit of sharp-pointed hardware having been placed upon someone's chair was always sure to bring down the paternal ire upon my head.

After spending thirteen years in Stillwater, my family moved to New York. We were folks of less than moderate means, and the cost of our journey, coupled with my being rather well set up for my years and having a healthy desire to put my energies to work, culminated in my looking for a job. After quite a search I was able to persuade John B. Collins, who was

then in business on 14th Street, that I would be a valuable asset to his business as a cash boy. Perhaps he was impressed by my earnestness, for he agreed to hire me at the grand and glorious salary of \$2 a week. After the first week, however, he showed signs of impatience. The end of the second week found me with my second \$2 but without a job.

## DREAMING AND SELLING BOOKS

**D**URING the next year or so I landed, and lost, one job after another. I cannot blame those good but gossiping persons who came to regard me as the family black sheep and ne'er-do-well. Yes, I was shiftless and a dreamer,



EDNA BALDWIN

This young pianist is a popular member of the popular "Gang"

THREE CAPITOL—  
AND THREE—

They have contributed—  
evening concerts given—  
transmitted, through—  
enthusiastic and in—



ERNESTO LECUONA

He is a Cuban pianist, and has been playing some of his own compositions at the recent Sunday night concerts



but in all my shiftlessness I was building up, entirely unknown to myself, a symposium of impressions which has followed me through the years and left with me a keener, deeper and more appreciative picture of human frailties and kindnesses. I have been in intimate contact with some pretty rough characters, but have yet to find the one in whose soul there is no flame of decency or humanity or even a hidden love, despite an exterior that would indicate none of these attributes. There is, I believe, a way to the heart of every one of us—and when the way is found, true friendship follows.

But that is somewhat aside from my past, though it may serve to reveal a part of the

—PIANISTS

—CAPITOL VOICES

- greatly to the Sunday
- at the theatre and
- Station WEAF, to an
- creasing radio audience



© Underwood & Underwood  
MME. ELSA STRALIA

From the Royal Opera, Covent Garden, London. She possesses a dramatic soprano voice and has had great success in opera and concert abroad for a number of years. She is a native of Australia, and came to America in 1922



WILLIAM ROBYN

Alias "Billy." His lyric tenor voice is heard from time to time at the Capitol. He has also made Victor records and now has a long-term contract with the Cameo Phonograph Company



LOUISE SCHEERER

This contralto has long been a member of the "Gang," and sings in the Capitol quartet

mental processes, born years ago, which remained unshaken as the days rolled by.

When I was still in my teens, I became a book-agent and made myself a most unwelcome visitor at many homes. I believed in the books I was offering for sale, felt sure they would bring pleasure and profit to those who would read them; but the reception extended me, as soon as the object of my mission was made known, was a most frosty negation. This kind of thing discouraged me greatly. I found it difficult to reconcile my ideas of what life should be, with life as I found it.

Like many another discouraged youth who finds it hard to make an honest living and has



(LEFT) THE "BLUE  
BLOND"

Otherwise known as Dr. Eugen Ormandy, concert master and soloist at the Capitol Theatre

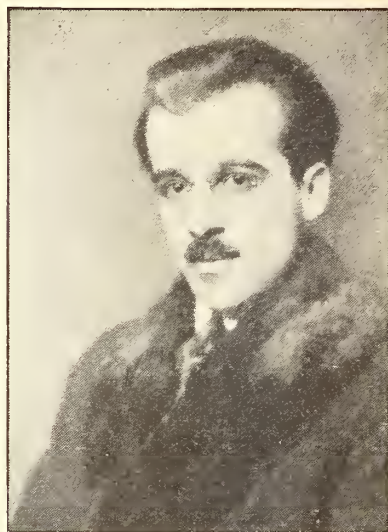

(RIGHT) ERNO RAPEE

Whose dynamic baton has conducted the various programs at the Capitol. Born in Budapest, he enjoys the reputation of being a brilliant pianist and a composer of no small talent. He has conducted symphonic concerts and opera throughout the principal cities of Central Europe

no particular trade or talent to fall back on, I joined the Marines. The years of my enlistment were among the best years of my life. I met other young men from every walk of life and profited by my contact with them. My duties took me to all parts of the world and my vision was broadened as only travel can broaden one. The discipline, exercise and training were entirely different from anything I had previously experienced. It quickened my actions, sharpened my wits, and provided me with a feeling of independence and self-confidence I had not known before.

Fortified by this training, I undertook again what I had found to be my hardest job: I became a comparatively successful book-agent. My book peddling carried me into the coal fields of Pennsylvania, and it was in Pennsylvania that I met my wife-to-be. We soon found that the old saying that two could live as cheaply as one was never set to music by a married person. Our entrance into matrimony cut a rather large slice in the family fortune and we held a council of war on the two subjects of Finance and Future.

The findings of the council were that we should go into the motion-picture business immediately. So we did. That was about fifteen years ago. In a small town in Pennsylvania we were able to locate room enough to accommodate a fair-sized audience, behind a bar-room. The hall, as it was called, was used for meeting purposes and it was supplied with camp chairs by the local undertaker. Inasmuch as the same chairs were used for meetings, funerals and our movie enterprise, our per-

formances were more or less movable feasts, sandwiched in between the other uses for the camp chairs.

This family "theatre" of ours called for a great deal of work and though my wife had all the duties of our small home to bother her, she still found time to assist and encourage me when the burden at the show-house was particularly heavy. I did the janitor work, painted the signs, secured the meagre publicity available, and attended to the thousand and one details of the small-town theatre.

After the evening performance, when the audience had left and the house had again been put in order, I used to experiment with the projector in an effort to improve the quality of our pictures. Then, too, there was the presentation to be worked out, for, even in those days, I played a great rôle in the success or failure of the silent drama. In order to save enough to pay the musicians and others it was necessary for me to run my own machine. But the return for all this effort was not great, and showed me that the field was not large enough.

I went to Philadelphia after a job and was taken up by the Keiths. During my stay there, I originated and developed what has come to be called twilight projection, which is a system of subdued lighting making it possible to do away with the dark theatre.

#### A MEETING WITH SARAH BERNHARDT

LATER, when I was working in Milwaukee, it was my good fortune to meet Sarah Bernhardt whose screen version of "Queen Eliza-



beth" we were showing. She encouraged me greatly by commenting favorably upon the presentation of her picture and predicting a great future for me. This marked the turning point in my career, for this picture and its presentation secured national recognition for me.

Then I came to New York and opened at the Regent Theatre where I employed my own type of presentation which proved to be a sensation. Then I opened the Strand on Broadway and later built the Rialto and the Rivoli. At present I am finding the business of arranging the productions at the world's largest theatre the most difficult and absorbingly interesting job I have yet experienced.

As many of you know, last fall the American Telephone and Telegraph Company conducted a series of experiments at the Capitol Theatre which resulted in the broadcasting on a particular Sunday evening of our musical program. Reports from radio listeners-in came from Chicago, Canada, Cuba, Georgia, Kentucky and vessels at sea. All the reports contained enthusiastic approval and the experiment was repeated with such tremendous success that weekly concerts from the Capitol Theatre have now become a regular feature of the programs from WEAF.

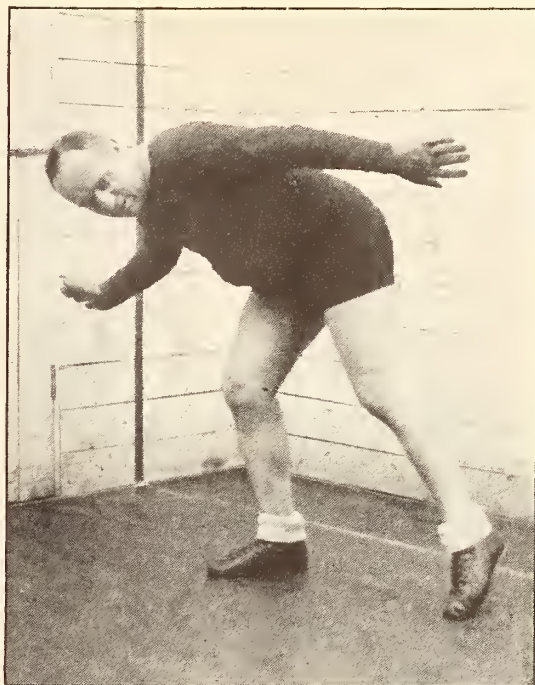

"ROXIE" OFF DUTY

He is an enthusiastic handball player. Recently he won the Handball Tournament at Rolley's Gymnasium, New York, where this picture was taken

The idea occurred to me as these broadcasts went on, that here was an ideal medium for us to use in making friends for the Capitol by sending the most beautiful of songs and music into the homes of the unseen audience. We were inspired by the thought that we could make life more livable and bright for those shut-ins who for one reason or another could not leave their homes, who, in a word, are deprived of those pleasures which we so freely enjoy and frequently fail to appreciate.

BROADCASTING WITH THE "GANG"

THE result was that we had a special studio arranged and each Sunday evening my "Gang"—composed of the artists who entertain in the theatre—and I have an hour before the microphone, poking fun at each other and at you, and sending upon the waves of ether the world's best music. It is one hour of the week to which we all look forward with pleasure, for during this hour we meet many friends who write us, approving our efforts and thanking us for the entertainment we give them.

We have been fortunate in being able to get personality into the microphone, and I believe that our departure from the regular method of

佳音  
 羅君知之  
 你乃世間之傑也  
 每禮拜晚以六空無雜  
 音樂悅眾量厚有  
 財有友吾無別想惟  
 望公伴身康健可  
 為此善作  
 並候安

The above means...  
 Dear Mr. Reichart!—  
 you are indeed generous and  
 unselfish in giving so much pleasure to  
 the public thro the Radio on Sunday evening.  
 Undoubtedly you have plenty of the  
 world's goods and friends. There is  
 nothing else that I can wish for you  
 than, May the River of All Good Things  
 keep you and your associates in good  
 health so that you all continue  
 the good work.  
 With grateful heart & esteem.  
 Respectfully,  
 Roy Hines.

AN INTERESTING LETTER SENT TO "ROXIE"

This is one of the many thousands that have poured into his office since the Capitol first went on the air





ON AN EVENING WHEN THEY PLAYED "OVER THE RADIO"

Left to right: Eugen Ormandy ("The Blue Blonde"), Yascha Bunchuk (a Russian, "Sheik of the Capitol"), Bruce Benjamin (tenor), William Axt ("Dr. Billy"—pianist), Louize Scheerer (contralto), Evelyn Herbert (soprano), Dorma Lee (in rear—contralto), "Roxie" himself, Edna Baldwin (pianist), and "Betsy" Ayres (soprano)

broadcasting has made listening-in more pleasant. Indeed, I have received some very complimentary letters, which indicate quite clearly that we of the Capitol have been responsible for the installation of receiving sets in many homes where they had not been considered previously. And I must say that my many years

of showmanship have only made me keener to produce entertainment of a nature that makes the audience feel thankful that they are alive and in a world where, despite the cynics, there is plenty of happiness for those who will make even a slight effort to brighten the lives of their fellows.

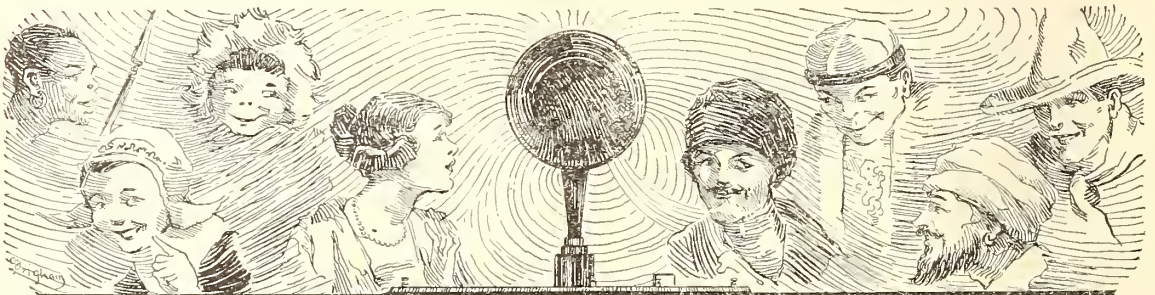



# Giving the Public a Light-Socket Broadcasting Service

How "Wired Radio," Invented by General Squier, is Being Employed to Supply News, Entertainment, and Instruction to Staten Island Subscribers at So-Much-a-Month. Economy and Reliability are the Chief Assets of the System Which may be in Use Everywhere Soon

By WILLIAM HARRIS, Jr.

**S**UPPOSE you had a compact little single-control receiving instrument which you plugged into any one of your electric light sockets and received, at specified times, the latest world and local news, music of all kinds, play-by-play (or blow-by-blow) reports of the big sporting events, extension courses in whatever might interest you, information regarding where to shop for everything from footwear to furniture, authoritative talks on the theatre, books, health, cooking, etiquette, and what-not—all with a minimum of interference, three hundred and sixty-five days in the year.

And suppose you could get all this at about half the cost and none of the bother or uncertainty of the common broadcast receiver.

You *can*—if you happen to live on Staten Island!

But if you don't, never mind; because the first commercially practicable "wired radio" broadcasting service, which has just been put into operation by the Wired Radio Service Company, gives promise of such universal popularity that similar services will no doubt spring up throughout the land almost before you have time to read up about it.

Of course the old-fashioned kind of broadcasting (about two years old now, isn't it?) will not immediately curl up its aerials and die, leaving a vast and sentimental radio audience weeping over the expensive carcass. No, the two services will continue side by side. You can probably think of various reasons why this will be so. Here are a few:

1. Fans will always want to tune-in "distance," both because it's distance and because arriving at success as a result of their own skill will never fail to give a very real pleasure.

2. The appeal of wired wireless is not primarily to the amateurs and fans—it is to that far greater part of the population which either does not own receiving sets or is temperamentally disinclined to fuss with them.

3. "Space" broadcasting will always be the more economical system in sparsely settled regions. The wired wireless service is essentially for towns and cities, where the expense per subscriber is low.

In brief, this is the way the Staten Island service came into being: The North American

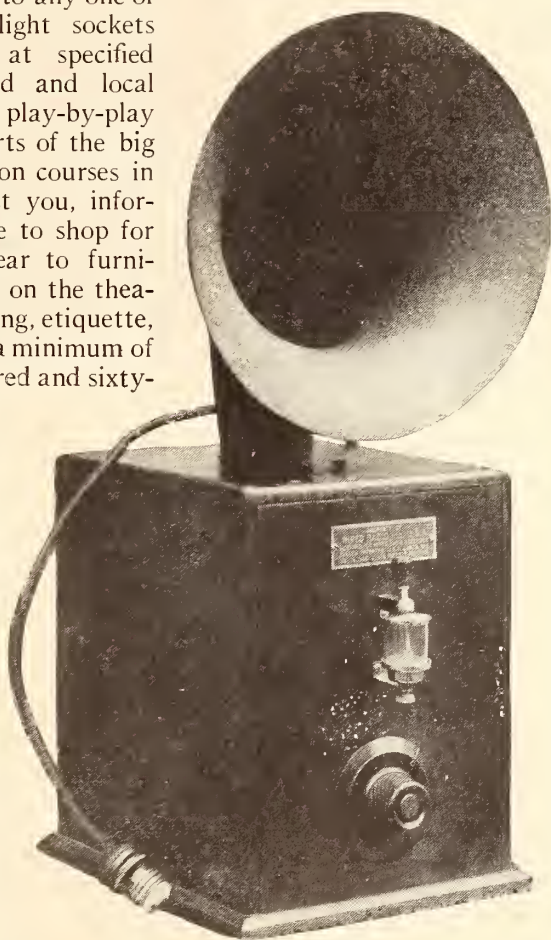

THE SET USED MOST FOR WIRED RADIO RECEPTION

The single tuning control is the outstanding feature of this two-tube receiver. A semi-permanent crystal may be clipped in place instead of the one shown. No A batteries are required as the lighting circuit supplies the filament current. To put the set in operation, the light switch is turned on; when the subscriber is through with the set, he simply turns off the light switch

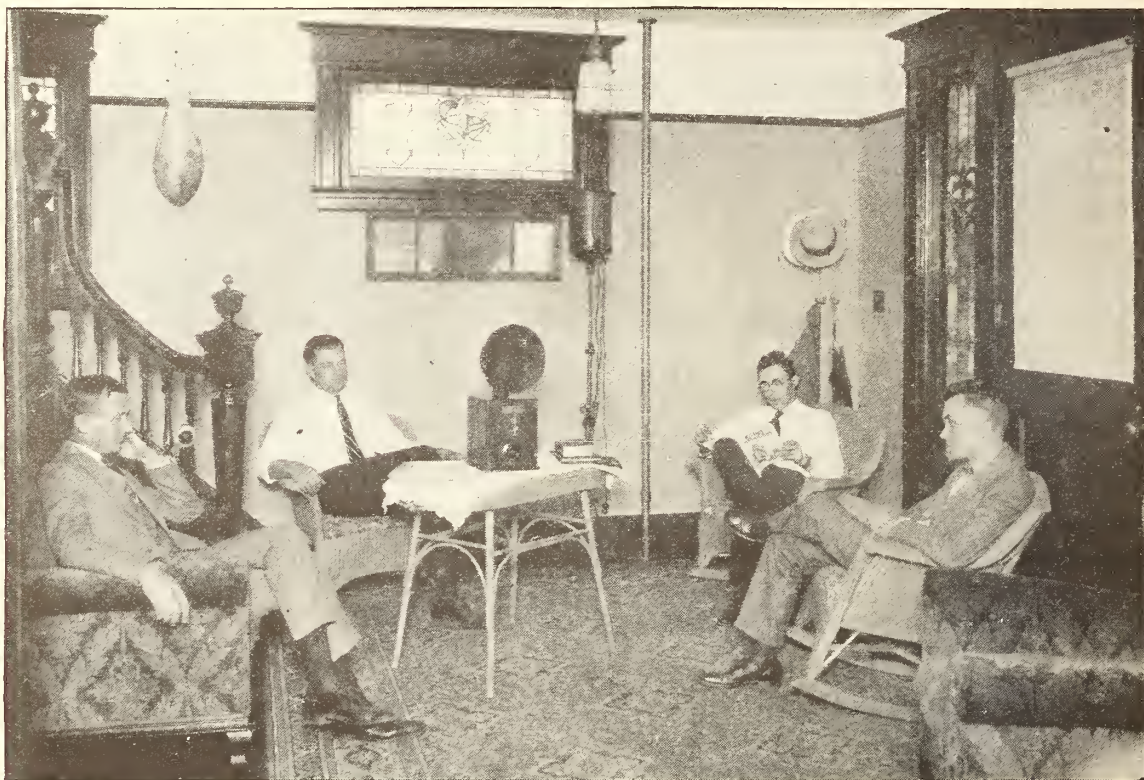

#### TRYING THE LOUD-SPEAKER SET IN THE ROOM ADJOINING THE STUDIO

From left to right: J. Arch Mears, President of the Wired Radio Service Company; E. W. Danals, who has aided in the development of the one- and two-tube wired radio sets; Samuel Isler; and R. D. Duncan, Jr., Chief Radio Engineer of The North American Company who formerly worked with General Squier at Washington and has been in charge, during the past year, of the experimental work of the Wired Radio Service Company

Company, a public utility holding company operating electric lighting and power companies in Cleveland, St. Louis, and many other places, obtained a sixty-day option from General Squier on a license to use his invention commercially. Experiments in Cleveland during this sixty-day period gave the officials of the company confidence in the tremendous possibilities of wired wireless if properly applied for public service. The license was obtained forthwith, and further experiments over the circuits of the Potomac Electric Company in Washington were eminently successful.

The rehearsals having been given, so to speak, the show was presented to the public—on Staten Island. Mr. C. W. Hough, President of Wired Radio, Incorporated, which is controlled by the North American Company, is in general charge of all this wired radio work; and the Wired Radio Service Company, mentioned above, is a subsidiary of Wired Radio, Inc., formed to carry on operations throughout New Jersey and in parts of New

York and Connecticut. It is this latter organization which has just started supplying a daily broadcasting service to Staten Island homes over the ordinary, unchanged house lighting wires.

Mr. J. Arch Mears, President of the Wired Radio Service Company, says:

There are about 25,000 potential subscribers to the service which we have established on Staten Island; but they are only a fraction of the number which our company expects to be supplying before long. When you consider that there are in the country 12,000,000 houses wired for electrical power, of which the organizations associated with the North American Company supply approximately 1,500,000 with electric service, you can see that if even a comparatively low percentage of these subscribed to the broadcasting service, the revenue from the tremendous business that would result would be sufficient to enable us to procure the very best talent, the most important and interesting programs. There are between 3,000,000 and 4,000,000 potential subscribers (families or organizations) within 200 miles of New York City, the greatest



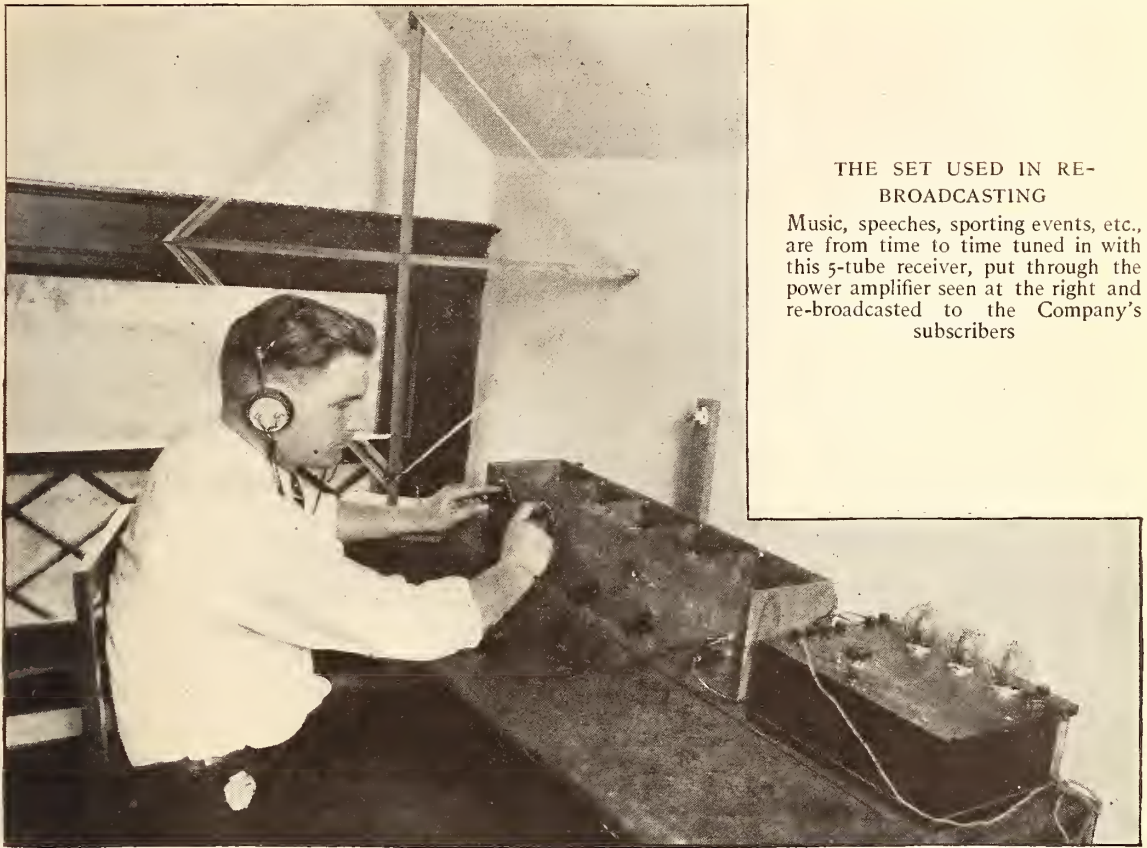

THE SET USED IN RE-  
BROADCASTING

Music, speeches, sporting events, etc., are from time to time tuned in with this 5-tube receiver, put through the power amplifier seen at the right and re-broadcasted to the Company's subscribers

program source in the world. The probable—in fact, the inevitable—growth of wired radio which we are going to see within a few years fairly staggers the imagination.

WHAT IS HAPPENING OVER ON STATEN ISLAND

**B**UT let us cross over to the broadcasting plant on Staten Island and see what is going on there. It is a half-hour ferry trip from the Battery to St. George, then a couple of miles' train ride to West Brighton, where the studio is located. The broadcasting is done from a three-story stucco house leased by the company. On the first floor are the reception room and studio, the latter, like the ordinary radio studio, being hung with heavy monk's cloth to absorb all sounds except those entering the microphone.

On the second floor is the transmitter room, containing the apparatus which delivers the radio-frequency impulses directly to the 2,300-volt power lines. There are two transmitters: the small one shown at the left in the photo on page 470 is a spare set for use in case the large set should be out of commission. The oil switch

for the 2,300-volt lines is seen mounted above the control panel in the centre.

THE WIRED RADIO NEWSPAPER

**I**N AN adjoining room is the automatic apparatus which receives news directly from the United Press Association's offices in the World Building, New York City; for not the least important part of the wired radio service is the news summaries delivered to the subscribers' loud speakers or phones at the same time that they are sent to some seven hundred newspapers all over the country. Mr. James T. Kolbert, of the United Press Association, is Editor of this newly established wired radio newspaper.

This phase of the service is not provided as a substitute, as one might at first imagine, for the ordinary daily paper of wood pulp and printer's ink. It is true that it supplies news of local and world-wide importance, but it is rather as an arouser of interest that its sponsors expect it to prove of greatest value. What is important or interesting for people to read about is told briefly.

Before long an advertising wavelength will be operated, at some morning hour suited to the convenience of the women, who are the chief buyers. They will be told, by women, just where and when to shop for their special requirements. It will be readily seen that the printed newspaper will always have the advantage that, although it may arrive several hours later than the radio bulletins, it can be picked up at the reader's pleasure, read as leisurely and as often as may be desired and contains much more completely the facts and discussions that are broadcasted over the lighting wires. It is expected, however, that the radio newspaper service will broaden people's interests in a way that a daily paper alone cannot do. Those whose interests have revolved chiefly about their own local worlds will find themselves following, from day to day, in the press and in the conversations of their associates, what the world at large is doing and thinking. This, if brought about on a large scale by intelligent and discriminating wired broadcasting, will be a tremendous thing. The instrument is a powerful one, and the responsibility that goes with the privilege of using it, is great.

#### DISTANCE MADE POSSIBLE ON A CRYSTAL SET

UP ON the third floor of the broadcasting house is a five-tube loop receiver, whose output may be switched directly on to the electric lighting lines and received by the subscriber. It need scarcely be pointed out that the chief significance of this phase of the Wired Radio Service Company's activities is that it makes distant programs available for crystal receivers.

Thus, we find three distinct sources of broadcasts—performers in the studio, news from the United Press Association, and space radio re-broadcasted—all sent over the same lines and audible to every subscriber whose apparatus—built by

and rented from the company—is plugged into one of his light sockets.

#### THE RECEIVING SETS SUPPLIED TO SUBSCRIBERS

VARIOUS types of sets have been designed and provided by Wired Radio, Inc. which are leased to subscribers at prices ranging approximately from two to five dollars a month. (This charge, by the way, is tacked on the subscriber's lighting bill.) All the sets have crystal detectors. The simplest one has a semi-permanent crystal and a single tuning control. The crystal is of a type which is less sensitive to weak signals than the ordinary mineral, but equally good on strong signals; and since all signals received over the lighting lines are as strong as necessary, this type of crystal is just the thing! The beauty of it is that after you have adjusted it by turning a thumb-screw slightly, it stays set for an indefinite period, in spite of jarring the table, moving the set from place to place, and other actions fatal to the adjustment of the ordinary crystal. These sets are designed for use with headphones.

#### JAMES T. KOLBERT IN THE NEWS ROOM

This room, on the second floor of the house, from which the wired broadcasting is done, is connected directly with the United Press Association's offices in the World Building in New York. Mr. Kolbert, a representative of the United Press Association, is acting in the capacity of Editor of the Wired Radio News Service

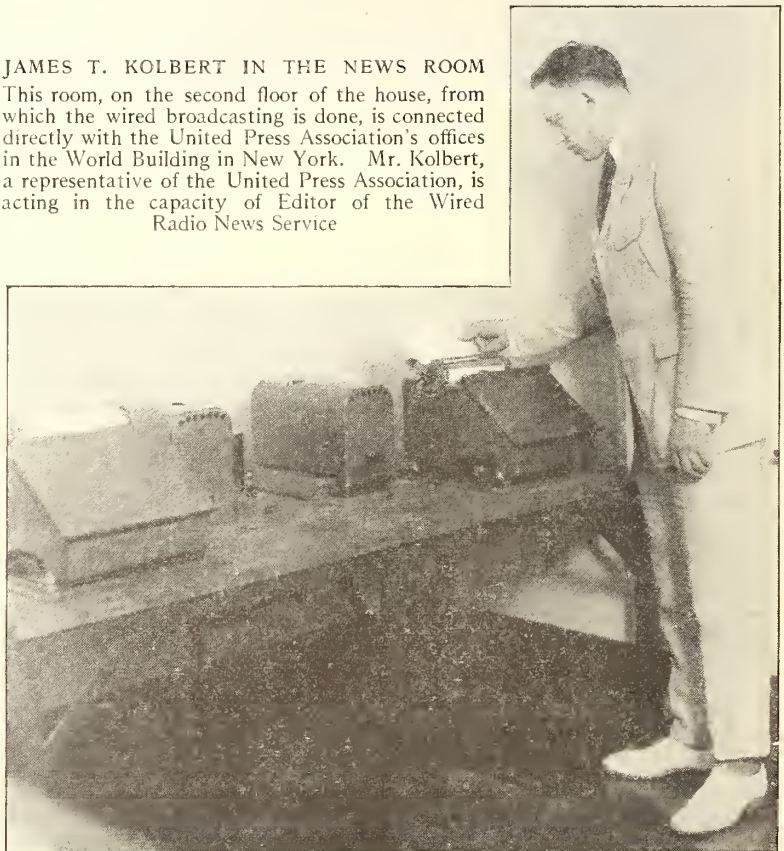



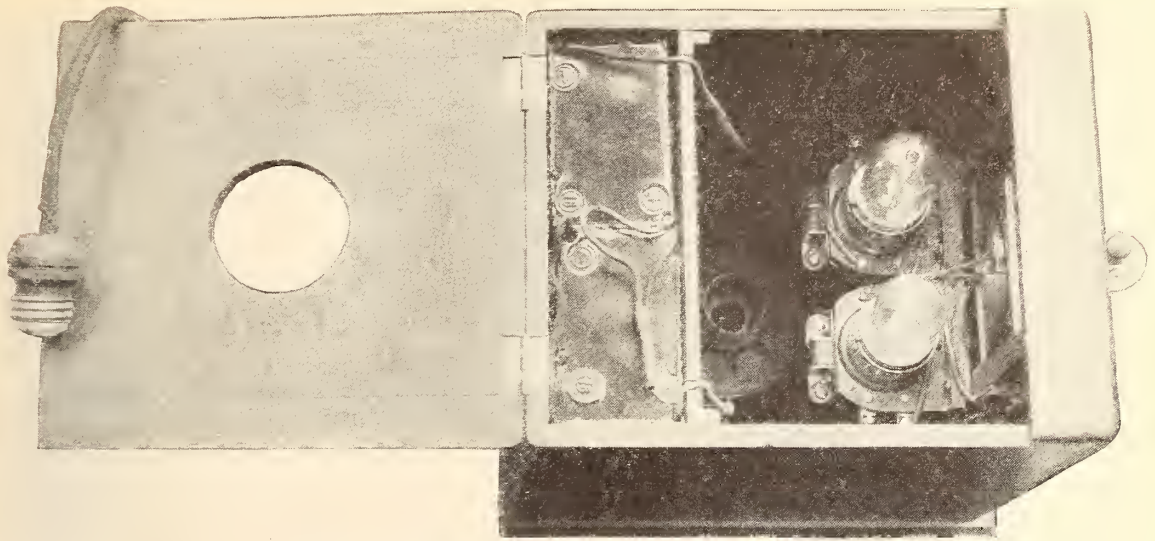

THE INSIDE OF THE SET SHOWN ON PAGE 465

On the left are the small B batteries; at the bottom is seen the loud speaker unit in which the base of the fibre horn is fitted; the two WD-12 tubes and the crystal (seen at the extreme right, outside the cabinet) give one R. F. stage, detector, and two A. F. stages, as one of the tubes is reflexed

Most people prefer to listen to their radio entertainment from a loud speaker instead of having to wear headphones, which are often heavy, and, in summer especially, decidedly hot. For such subscribers, a compact little outfit has been developed which reproduces signals received over the lighting lines with volume sufficient to fill the ordinary-size living-room. It contains only two tubes—WD-12's—but one of them is reflexed, so that the effect is obtained of one radio-frequency stage, detector (crystal), and two audio-frequency stages. This set is shown below and on page 465.

Still another receiving set, which has not yet been put in service, has been designed for use in stores, theatres, and other places where a particularly loud signal is needed. As in the case of the other models, the filament current will be supplied from the lighting wires, and the tuning will be simple enough for any one to master without much practice or instruction. Radio is thus handed to the non-technical, non-experimenting "general public" on a silver platter. There is not much to go wrong, and if anything does, a man from the company will come around and remedy the trouble, like the telephone service man. In other words, when a subscriber pays so-much-a-month for a receiving set, he is paying at the same time for whatever service may be necessary to keep it in good order.

There is no reason why one house should not

operate several sets at the same time if desired. No interference or diminution of signal results. And there is no reason why a triple socket, for instance, should not have plugged into it a toaster, a flat-iron, and a receiving set. As in the case of any other electrical appliance, the radio set, when once connected to the socket, is put in use simply by turning on the electric light switch.

At present, all programs are transmitted on the same wavelength—about 8,000 meters—but the company expects soon to operate a dance wavelength, an advertising wavelength, and an educational wavelength simultaneously. Practically anything the subscribers indicate that they want in the way of programs can be supplied. If enough of them, for example, want a half-hour talk on books and literature each evening, they will be given it on a special wavelength. They will also be able to turn their single tuning control to dance music, which will be on tap practically every evening, or to opera, or lectures. This, it will be seen, approaches rather closely the "fantastic" imaginings of writers and artists a few years ago who pictured a small box from which all sorts of entertainments could be drawn at will, like things to eat at the Automat.

How quickly and how widely the public is going to take up wired radio cannot yet be foretold with accuracy. Nor can it be said how cheaply an A1 service can be offered to

large communities. The cheapness and the quality, of course, depend principally upon the number of subscribers obtained in any given district. In New York and the vicinity, for instance, the best conditions may well be expected.

Programs originating in a wired radio broadcasting studio in New York could be sent as far as Chicago if it were necessary to do so. But the difference in time in Chicago (which would make bedtime stories from the Metropolitan area, for example, an hour too early for the Windy City's younger generation), as well as the fact that people will generally prefer programs of more local interest, make it unlikely that wired radio will ever be used over distances of many hundreds of miles. Space broadcasting will take care of the long-distance work sufficiently well.

Wired radio, then, is not going to "revolutionize" broadcasting, since it differs greatly

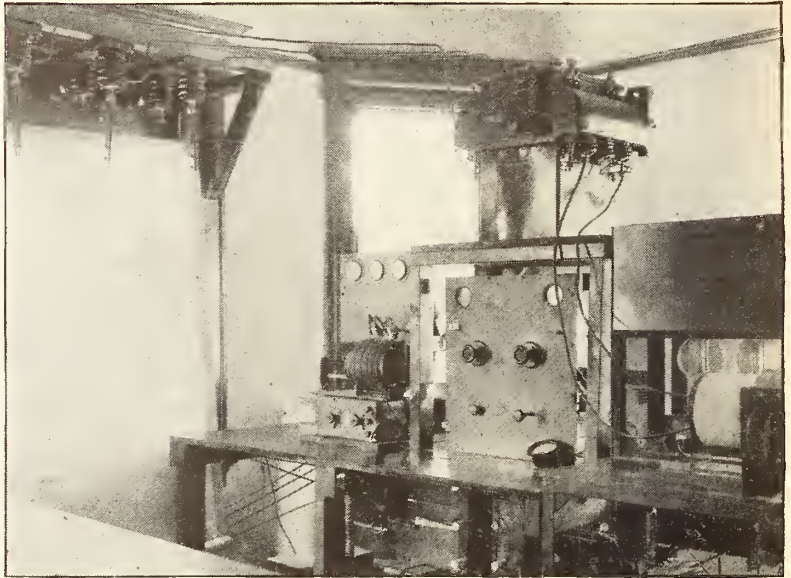

THE TRANSMITTING SETS AND THE LIGHTING LINES

The small set at the left is for use principally in emergencies. The larger set, at the right, is used regularly in broadcasting over the lighting lines. Above the control panel in the centre is the oil switch for the 2300-volt lines

from "space" radio as regards the people it appeals to and the service it offers. If it revolutionizes anything, it will be the point of view of thousands of people whose interest will be stimulated in things worth while, through a service within the reach of practically everyone.



BETWEEN THE ACTS WITH CYRIL MAUDE

The well-known English actor, who has been playing in "Aren't We All?" at the Gaiety Theatre, New York, tried out a receiving set in his dressing room. He failed to hear 2LO, near his home in London, but was apparently entertained by some local advice to housewives on preparing spinach





APIA, SAMOA—5000 MILES FROM 'FRISCO AND 2,500 FROM HAWAII

A small group of enthusiastic set-owners at this remote settlement are now hearing concerts from California regularly

## When the Bug Bit in Samoa

The Difficulties of Obtaining Apparatus on a South Sea Island, Experiences With Local Red Tape, and Final Success in Accomplishing 5,000-Mile Reception

By QUINCY F. ROBERTS

American Vice-Consul, Apia, Samoa

SAMOA is approximately five thousand miles from San Francisco and two thousand five hundred miles from Honolulu. Mails arrive twice every nine weeks. At the time of writing, March 25, 1923, I am reading in my latest New York paper a program transmitted by WJZ, forty-seven days ago. The January issue of RADIO BROADCAST has not yet arrived. My latest radio magazine is dated February 10, 1923, and I must await the arrival of the mail steamer sixteen days away before finishing a continued article on super-regeneration.

Interesting scenes, places, and peoples surround me. In the distance, part way up the ridge, I see the smoke of Vailima, Robert Louis Stevenson's old home. To the right is the wooded hill chosen by the beloved author for his tomb. Back of the Consulate I hear the beat of the hollow log, calling my brown-skinned neighbors to church. Tofaeone,

the Village Chief, barefooted, bareheaded, in spotless white coat and lava lava, glancing aloft to see if yesterday's storm has brought down my aerial, leads his subjects to service.

In the office are records dating back to 1857. The volumes of manuscripts contain the history of turbulent Samoa—a story of clashes between the Consuls, bitter commercial strife, bloody native wars, and the deeds of bold, desperate men cut off from the outer world without swift means of communication. Around the point on the reef and the beach lie the dismal wrecks of the U. S. S. *Vandalia* and the German warship *Alder*, monuments to the struggle between Germany, Great Britain, and the United States for control of the Pearl of the Pacific, Samoa.

Radio in the stormy past would have prevented bloodshed and saved the lives of our sailors. Wireless would have created new island empires in the South Seas. Its use, in

fact, would have changed Pacific history, for the naval and consular authorities of the interested powers were without instructions when they were sorely needed. Immediate action was imperative; decisions were reached without the guidance of the home governments. Radio, annihilating distance, would have settled the questions between the nations and more than fifty years of political struggles and warfare in Samoa would not have been written.

To-day, Apia is linked with the rest of the world by a high-powered radio station. Its four-hundred-foot umbrella antenna and its two sparksets of eight and sixty kilowatts keep open the lines of communication with New Zealand, Fiji, Tonga, Tahiti, Australia, American Samoa, Hawaii, and California. VMG, as Apia is known in the wireless world, is the link between Paris and the French colonial empire of the South Seas. How differently situated were my predecessors in the South Pacific before the age of radio, when telegrams were dispatched by mail to Auckland, New Zealand, to be transmitted by cable to Washington.

Each day the Minister of External Affairs in Wellington, New Zealand, condenses the world's news into a hundred-word radiogram for Samoa. At odd moments between commercial messages the operators at VMG listen in for the press news from Hawaii to the Far East. Apia with its small weekly newspaper cannot support a press service, so that the stray bits of news collected by VMG and the Minister's telegram make up the press news. You with your tremendous news-gathering agencies serving up the last-minute news by radio, telegraph, cable, telephone, steamship, railroad, and aeroplane, can little imagine how eagerly the short news bulletin is assimilated by the starved whites of Samoa. People cluster about the board, chewing over and over the slender morsels, seeking the interpretation of an obscure phrase or a missing word dropped by an operators' carelessness or a crash of static.

The radio bug, migrating south and west from the United States, has reached this peaceful

island and a severe outbreak of radio amateurs is expected by the Radio Officer of Samoa. Eighty-four regulations, numerous forms, and various licenses are ready to cope with the impending infection.

Some time ago the Editor of RADIO BROADCAST requested me to write an article on radio and its uses in the South Seas. He told me that interesting stories of radio in places remote from Manhattan are appreciated by readers of the magazine. Eight months ago, when his letter arrived, I knew little about radio. Of course, I knew that Apia Radio handled my telegrams efficiently and supplied me with American election returns. The operators occasionally called me up to read messages out of hours. Now and then I had noticed short news items in the New York papers about the opening of broadcasting stations. I had seen the radio programs sent out by the high-powered stations in the United States, but the great developments in radio since my departure from the United States had escaped me.

My wife was reading a letter from home when I happened upon the Editor's letter.

Looking up, I casually remarked, "The radio craze must be sweeping the United States. Here is a letter from Doubleday, Page and Company about a magazine called RADIO BROADCAST written for radio fans. Let's get a radio outfit."

"That's strange," she replied, "I was going to say the same thing. My sister writes me about the concerts she receives on her new radio receiver."

Blissful in our ignorance, we discussed the wonders to be brought about by the new instrument. The World's news would be ours. In Samoa we would listen to London, Paris, Berlin, Rome, and Washington. Speeches, music, and operas from the United States would break the monotony of our island life. Thus did the Editor's radio bug mark two more victims, and the ranks of the radio amateurs in Samoa increased three-fold.

Then my hectic life as a radio amateur began. Perhaps you prefer the term novice, but continue with me—I am certain that you will ac-



QUINCY F. ROBERTS

Who relates the experiences of a broadcast fan miles from "civilization"



cord me the distinction of being called an amateur.

First, I needed information. The radio operator of the mail steamer reluctantly left the cool shadows of the village swimming hole to have luncheon with me. Carefully we went over the ground. He said that I needed a good text book on radio, a radio magazine, a receiver ranging from 200 meters to 24,000 meters, a two-step amplifier, tubes, batteries, and telephones. He produced a worn copy of an American amateur radio magazine published in 1920, and we made out the order amounting to \$120.00 for my San Francisco agents to purchase and ship to me.

The U. S. Naval Radio Station at Pago Pago, American Samoa, supplied me with Bucher's "Practical Wireless Telegraphy" and I plunged into study of radio theory while waiting for the arrival of my equipment two months hence. I floundered through magnetism, induction, electrical measurements, and intricate circuits. I pored over diagrams and pictures, trying to visualize curious instruments and apparatus strange to the South Seas.

I learned that a buzzer for code practice could be made from an electric bell, so the beach was combed for the bell. Only one could be found in all Samoa, and as this was used in the local garage to test ignition circuits the

engineer would not part with it. At last I landed at the Public Works Department and made known my want.

Next the key and dry cells. The strip of brass along the edge of the office rule and the handle of the library paste brush were commandeered for the key. The Apia merchants were without a single cell. Their shipments had missed; none would be available until the arrival of the next mail. Following a very slight clew, I discovered six dry cells on board one of the copra boats. Considerable argument induced the owner to lend me the cells until the arrival of fresh supplies. Code practice began.

Weeks passed and the steamer which was to bring my radio set arrived. No wireless material was on the manifest and there was not a line in the mail to tell me why the shipment was not on the steamer. Three weeks later a letter arrived from Fiji from the representatives of my San Francisco agents saying it was not understood why the enclosure was sent to Fiji. I looked at the enclosure. It was a letter from San Francisco. The radio set would cost \$475.00, consequently new instructions were desired. A two-page folder described the outfit. There were no catalogues, no magazines, and no books. I found the lot of a radio enthusiast in Samoa very hard. Four months

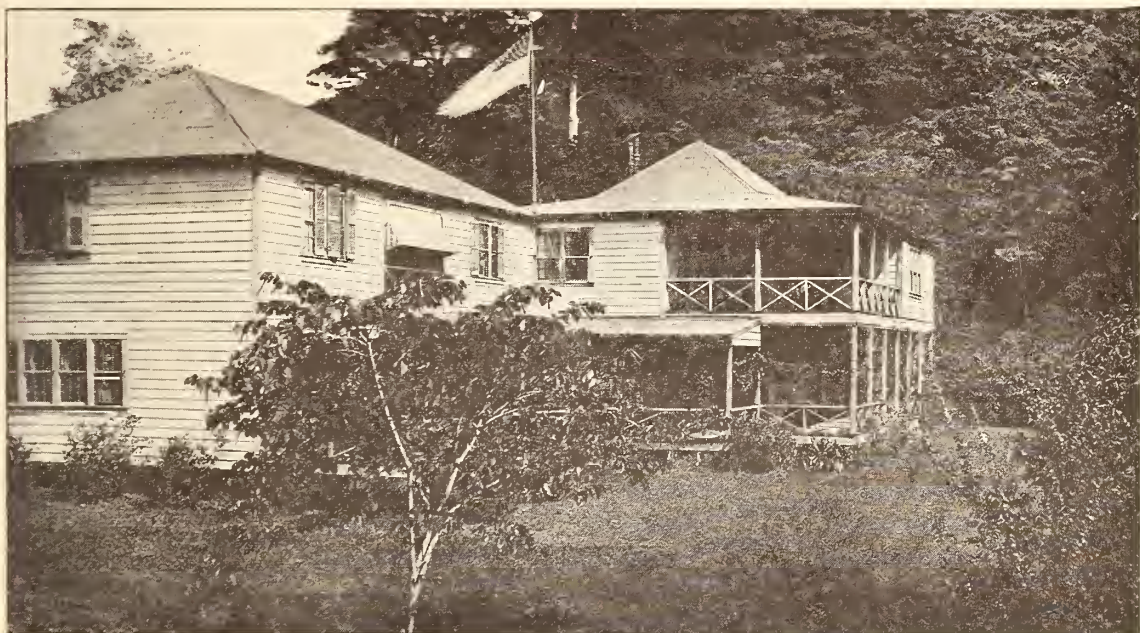

ROBERT LOUIS STEVENSON'S HOME IN SAMOA

It was here that Stevenson spent the last four years of his life—1890-1894





RADIO AMATEURS OF WESTERN SAMOA  
Mr. and Mrs. (Doctor Regina Keyes) Roberts  
in their garden at the American Consulate

must elapse before the arrival of my radio equipment, two for the catalogues and two for the order to arrive.

By this time my radio education had shown considerable progress. Why wait for a tube set? A crystal set could be made in my work shop and the experience would be useful to me. After two days' search I found 300 feet of cotton-covered No. 18 bell wire, the only small wire in Western Samoa. No one knew why it had been imported. Three dozen  $\frac{3}{16}$  inch brass machine screws, the entire stocks of the garages and hardware stores in Samoa, were purchased for the multiple point switch. Part of the strip of brass from the office rule and the handle of a passport visa stamp completed the switch assembly. Three drug containers placed end to end and wrapped in oil paper served as a tube for winding the single coil I planned. A piece of galena crystal was given me by the radio operator on an American yacht

which was in port. The spare telephones on board could not be purchased, but I borrowed them until the arrival of my head set. A coil of No. 14 bronze wire quietly taken from the telephone scrap pile was used for the aerial. My eighty-foot flag pole and a near by cocoanut tree served to support the antenna. Father Dumas, a Catholic missionary and my lone brother amateur in Samoa, came in to inspect my work. At his station, forty miles from Apia by boat, he had been experimenting with radio for more than six months. He was the proud possessor of a loose-coupler, Baldwin telephones, one variable condenser, and three pieces of crystal. He overhauled my aerial. Critically he examined my coil.

"A single-wire aerial is no good," he said. You will not get results. The wire on your coil is too large. The connections on the switch must be soldered."

Mr. Dunwoodie, Radio Officer of Samoa, met me and said he heard that I contemplated installing a receiving set.

"Better put in an application," he advised and handed me a long form.

It called for my full name, nationality, the nationality of my antecedents for three generations, my knowledge and experience with radio, and the circuits to be used. At the bottom was a space for my signature to the oath of secrecy which bound me never to divulge public messages and never to permit any unauthorized person to use my equipment. Three weeks after handing in my application I called to learn my fate. The Colonial Secretary pushed a large mass of papers toward me. It was my application with sheet after sheet of endorsements and comments attached to it.

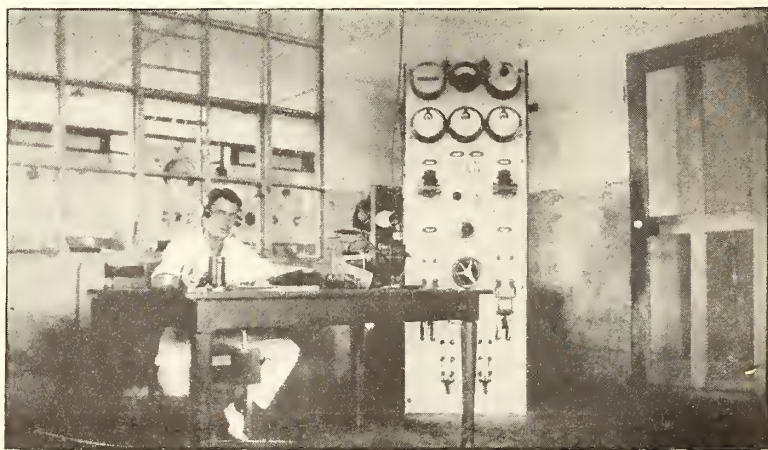

THE RECEIVING ROOM AT STATION VMG





NATIVE SAMOANS PUTTING THE ROOF ON THEIR HOUSE

First, it had been referred to the Commissioner of Police and the Superintendent of Mental Hospitals in Samoa. He recommended that it be referred to the Radio Officer of Samoa. The Police Department, after carefully considering the application, had found that it was without regulations. The Radio Officer was without instructions from New Zealand as to the policy to be followed in granting amateur licenses. He suggested that the question be referred to the New Zealand Cabinet. As to the particular case before him he saw no objection to granting a temporary permit for a crystal set. The opinion of the Crown Law Officer followed. Acts of Parliament, Orders in Council, decrees, ordinances, and laws were marshalled in bewildering array. To my befuddled brain the decision was: "New Zealand regulations may or may not apply to Western Samoa." I was permitted to install the crystal set pending a final decision from New Zealand.

We were impatient to begin. The Samoan village had not missed a move. Village lads jumped to stretch the aerial and make it fast to the top of the coconut tree. Tofaeono called for his Sunday suit and his Chief's badge to come to the trial. The last connections were made and I searched the crystal for a good point. VMG came in clear as a bell. The telephones passed from head to head. The air had

been conquered and it was yielding up its secrets in dots and dashes. Tofaeono was elated. The white man's magic was in his village. His fame would spread throughout Samoa. His orators could boast of the only wireless station outside the commercial station. We could not read the signals, but they came in strong. My home-made outfit was a success. I did not learn until long afterward that any coil and an ordinary land telephone receiver would bring in VMG's signals.

The Radio Officer and I were now very good friends. He respected my enthusiasm if not my knowledge of radio. He agreed to help me in my difficulties. Three new radio receivers had arrived for experimental work at the radio station. Concerts were being tuned in nearly every night on the new receivers. The operators were enjoying music from Honolulu broadcasting stations. One of the new receivers would go to Father Dumas and the other spare one could be sold to me. Dunwoodie installed the receiver. Under his expert hand, Tahiti, Tutuila, and Nukualofa came in.

"Here is the concert from Honolulu," he said, "But you will not recognize it as a concert."

I listened. Yes, music was surging through the whistle. Now and then I thought I heard a word. It was a great day in Samoa.





© Underwood &amp; Underwood

#### ONE OF OUR RADIO OUTPOSTS IN A PICTURESQUE SETTING

A view of the harbor and steep hillsides of Pago Pago, island of Tutuila, Samoa, showing the towers of the U. S. Government station

Since that time KHJ, KF1, and KPO, all California stations and 5,000 miles away, have been heard many times. My single-tube regenerative set has grown too small. I am now waiting for materials and supplies for super-regeneration and radio-frequency amplification. The radio fever is in my veins. More magazines, more books, and more equipment are the only palliatives that bring relief.

My wife and Father Dumas and I are proud of the amateur work in Samoa. We have no Radio Relay League, we do no DX work in the small hours, we have no transmitters. They are to come. Our little radio club of three has blazed the trail for those who follow in our footsteps. Regulations governing the use of radio for experimental, broadcasting, or amateur use are now in force in Western Samoa. A telephone transmitter is in Apia for installing on the Island of Savaii; another should arrive next week for the other side of Upolu. The Governor saw our work and became convinced

that radio telephony is feasible for inter-island communication. Three applications for receiving permits are now pending. Other people are interested. The local theater is planning to install radio receivers for the public. A broadcasting station in Samoa is being discussed. All this has been brought about by our little radio club.

Running true to form I can not refrain from boasting of my own achievements. On my single-tube regenerative set, eliminating all spark stations and C. W. telegraphy, I have logged 450,000 miles in 90 days (counting each station every day it comes in). My letters to KHJ reporting the reception of their programs at my station have been broadcasted by Uncle John. Fellow radio fans in the United States have flooded me with requests for postage stamps, seeds, and diagrams of my circuits. They say that one third of my results would satisfy them. Am I awarded the title of amateur?



# In the Wake of the Contest Winners

Four Complete "How-to-Make-it" Articles by Runners-Up in the Receiving Contest Who Merit Honorable Mention. A Summary of the Contest Results

In the August number, we published the article by Mr. Richard Bartholomew, of Porto Rico, which won the contest held "to determine who has done the best work with any kind of receiver and any number of tubes." Last month appeared the second, third, and fourth prize articles, submitted by Mr. Eric G. Shalkhauser of Peoria, Illinois, Miss Abbye M. White, of Hanover, Pa., and Mr. Harry Blumenfeld, of Cleveland, Ohio, respectively. These four winners did excellent work, and we heartily congratulate them. They had some pretty close competitors, too—broadcast enthusiasts who not only deserve some recognition of their efforts, but whose articles on construction and operation, and whose photos and diagrams are much too good and too useful for those of you who "build your own," to keep out of the pages of RADIO BROADCAST. So here they are. We shall always be glad to hear from readers who experiment with sets described in these—or any other—articles.—THE EDITOR.



## AT THE RIGHT YOU SEE THE MAN WHO WON FIRST PRIZE

When Mr. Bartholomew, who captured first place and the DeForest four-tube reflex loop set, sent us his photo, at our request, he said, "I'd be glad to hear from any one using this circuit of mine (or better, any one copying my set), whether they have success or not"

## A Better Broadcast Receiver

Mr. Munzig Has Pulled in 87,870 Miles Worth of Stations With the Outfit Here Described, 13 Stations Being More Than 2000 Miles from His Home in Redlands, California

By ARTHUR L. MUNZIG

(HONORABLE MENTION)

**N**EARLY every old-timer in this fascinating radio game has some certain method of radio reception or transmission that he specializes on. The writer, having used an arrangement a little out of the ordinary, wishes to present to the readers of RADIO BROADCAST a design he uses that results in a *better* regenerative receiver. This receiver has the advantages of both tickler- and tuned-plate methods, oscillating and regenerating over a broader waveband. Moreover, the arrangement gives *increased signal strength* over all other methods tried. The writer frankly believes this regenerative design to be the most efficient and sensitive regenerative method now available.

The one little instrument in this receiver that is responsible for this super-sensitiveness con-

sists of a variometer with an inductance coupled on to the left side of it. To embrace the broadcasting, amateur and commercial wavelengths, 65 turns of No. 24 D.C.C. copper wire are wound on a tube  $3\frac{1}{2}$  inches in diameter and 4 inches long. Taps are taken at the 25th turn and at the end of the wire by inserting small binding posts. A flexible lead is then used to change the amount of inductance desired by inserting it in the first binding post for 200-360-meter broadcasting and in the last post for commercial telegraph stations or any reception up to 800 meters. From the photo, Fig. 1, the reader can get an idea of how all this is done. The tube used to wind the wire on was a salt box. It would be better to use a fiber or bakelite tube because of its superior insulating qualities. If the salt box is used, however, take care to coat the box with shellac to ex-

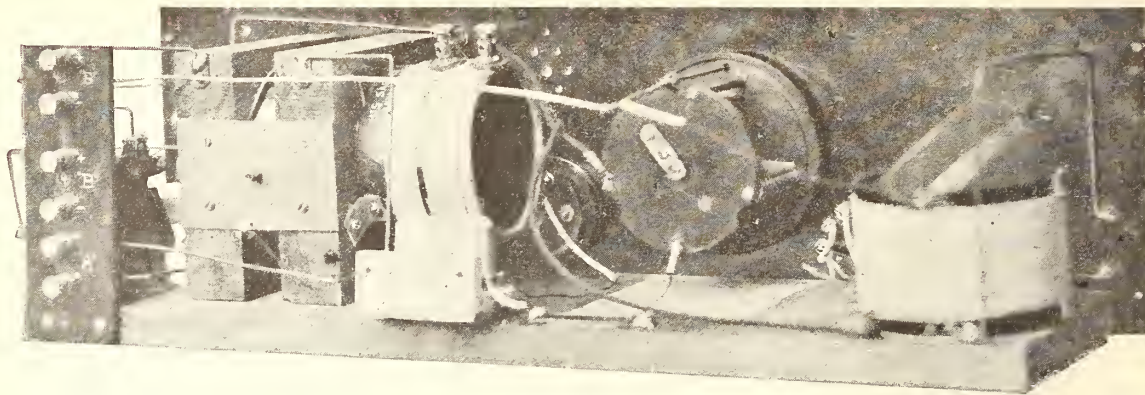

FIG. 1

Showing how the inductance is placed with relation to the variometer

clude moisture. Using two small brass angles, the inductance is fastened to the variometer, as seen in Fig. 1.

If the reader wants to include longer wavelengths than those covered by this receiver, all that is necessary to do is to wind a larger number of turns on the salt-box inductance. Bring out a tap about every 15 or 20 turns and fasten them to contact points and a switch on the panel. If wavelengths up to and including 6000 meters are desired, make the inductance bank-wound<sup>1</sup>. If this is done, don't forget that it is also necessary to load the antenna circuit.

This regenerative receiver was originally designed for 200-meter reception, in which capacity it functioned very efficiently—but, with the advent of broadcasting, a secondary load was needed to tune properly to these comparatively longer wavelengths; so an inductance was added in the grid circuit. Desiring to get the most out of the set that could be had, this load coil was placed in inductive relation to the plate circuit, to take advantage of the radio-frequency present. You can imagine the writer's delight when this resulted in a *decided increase* in signals!

In Fig. 2 is given the circuit used. Circuit students will recognize this as the Paragon circuit—but with a few modifications. A variometer is used to tune the plate circuit, while a variable condenser and a secondary load tune the grid circuit. Regeneration and oscillations are obtained by tuning the plate with the variometer and by having the grid and plate circuits in close proximity.

<sup>1</sup>Such inductances can, of course, be bought. Instructions for bank-winding will be given in detail in an article by Jesse Marston in next month's RADIO BROADCAST.—  
THE EDITOR.

One stage of amplification was all that was desired by the writer, the assumption being that if signals are audible on one stage of amplification, two stages increase only the volume of sound. It also magnifies the noises of the tubes as well as atmospheric disturbances. If the ear is subject to loud signals continuously, it becomes less and less responsive and eventually its susceptibility to weak signals may be deadened. So you can see the advisability of no audio amplification (when using phones), or if any, just one step.

Below is given a list of materials necessary for the construction of this receiver:

- 1 Bakelite panel 6" x 21" x  $\frac{3}{16}$ "
- 1 White pine base 7" x 20" x  $\frac{3}{4}$ "
- 1 Large knob and pointer
- 1 Switch and contact arm
- 8 Contact points
- 2 Stops
- 2  $\frac{3}{4}$ " knobs and dials
- 2 Rheostats (one with vernier)
- 10 Nickeled binding posts
- 1 1" x 6" terminal panel
- 1 Set of parts for a Crosley variometer
- 1 Set of parts for a Crosley variocoupler
- 1 43-plate variable condenser
- 2 Porcelain tube sockets
- 1 Grid condenser
- 1 Federal amplifying transformer
- 2 Phone condensers (.001 mfd.)
- Enough No. 24 D.C.C. copper wire to wind secondary load
- Enough No. 14 hard-drawn bare copper wire to connect the respective parts

Using the insulated copper wire furnished with the variocoupler, 80 turns are wound on the stator tube, a tap being brought out at every 10th turn. This makes a total of 8 taps, which are soldered to the 8 contact points and switch, as shown in the circuit diagram in Fig. 2.

Not much difficulty should be experienced in assembling the variometer. Care should be



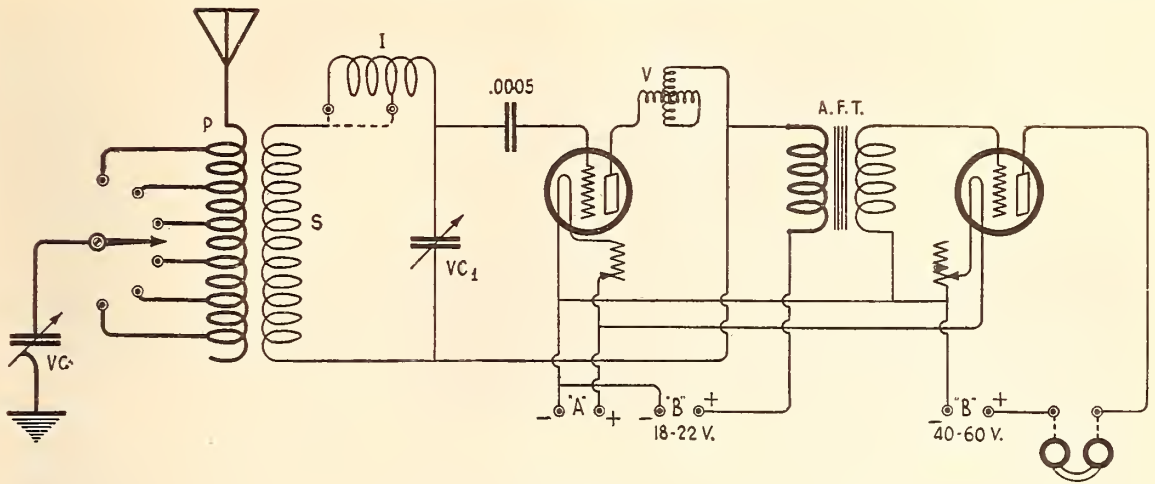

FIG. 2

Mr. Munzig's hook-up, a modified "Paragon" circuit; vc may be omitted

exercised in getting the rotor and stator windings wound in the same direction. Otherwise their mutual inductance will not change and the variometer will not function properly. The bearings for the rotor shafts were not strong enough and so were substituted with larger ones cut from heavy sheet brass. This added a rigidity that the bearings furnished could not give.

Fig. 3 shows the front view of the receiver. An idea of the panel layout can be had from this. The controls from left to right are: coupling control of the variometer, primary inductance switch, variable condenser control, detector rheostat control, plate variometer control, amplifier tube rheostat control, and the output binding posts. The binding posts at the extreme left are: the upper one for the antenna and the lower one for the ground. A variable condenser has been used in the ground

for close adjustments—however, it can be left out.

An idea can be had from the photo, Fig. 1, of how the respective parts are arranged and how connections are made. No. 14 bare copper wire was used for connections between parts.

The variable condenser seen in Fig. 1 is an old Murdock instrument that was pressed into service. The shaft was lengthened by soldering a small piece of the same size shafting on, covering them both with a small brass sleeving. So far it has given no trouble.

The "engraving" on the panel was done by scratching the highly polished panel with a sharp tool, using a steel rule as a guide. This left a fairly deep impression into which white crayon was rubbed. The circular arrows were made the same way, but with a steel compass. It's easy—try it!

FIG. 3

The dials and knobs, from left to right, control: the secondary of the variocoupler (S in Fig. 2), the taps on the primary (P), the variable condenser (VC1), the detector tube filament, the variometer (V), and the amplifier tube filament

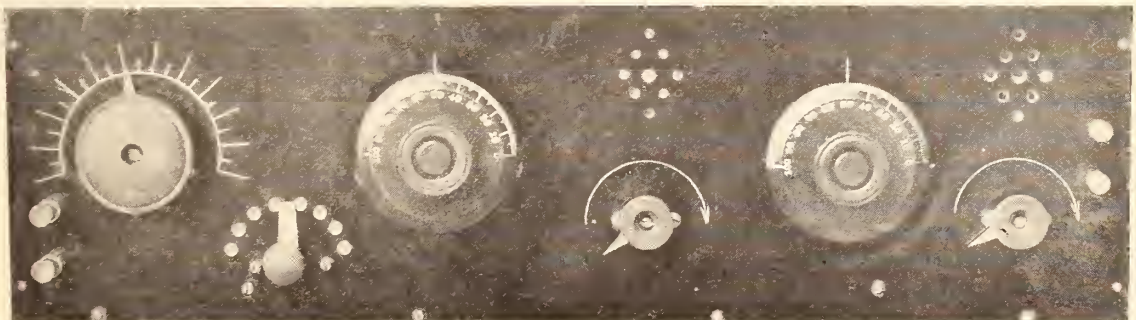

# A Set You'll Like to Make

A Michigan Fan's Complete Data for Building a Simple Regenerative Outfit. Can You Do as Neat a Job as His?

By FRANK NELEM  
(HONORABLE MENTION)

**F**OR those who desire a receiving set which is inexpensive, quite simple in operation, and which will give excellent results, especially on distant stations, I am giving a list of materials and detailed instructions for building and operating a short-wave receiver of the single-circuit feed-back type. One or two stages of audio frequency amplification can very easily be added to it if desired.

The following is a list of materials needed:

- 1 Panel 6" x 21" x  $\frac{3}{8}$ "
- 1 Variable condenser (vernier adjustment if possible)
- 4 Oz. No. 23 single silk covered magnet wire

- 2 Inductance switches
- 16 Switch points and 4 switch stops
- 6 Binding posts
- 1 Combined grid leak and condenser (grid leak, 1 megohm; condenser, .0005 mfd.)
- 1 Porcelain tube socket
- 1 Vernier rheostat
- 1 UV-200 Radiotron detector tube
- 1 .001 Fixed phone condenser

This list of materials amounts to about \$15.00 without batteries or phones. Of course the WD-11 or dry-cell tube may be used instead of the 6-volt tube with fair results, but personally I prefer the 6-volt tube, especially for use with a stage of amplification.

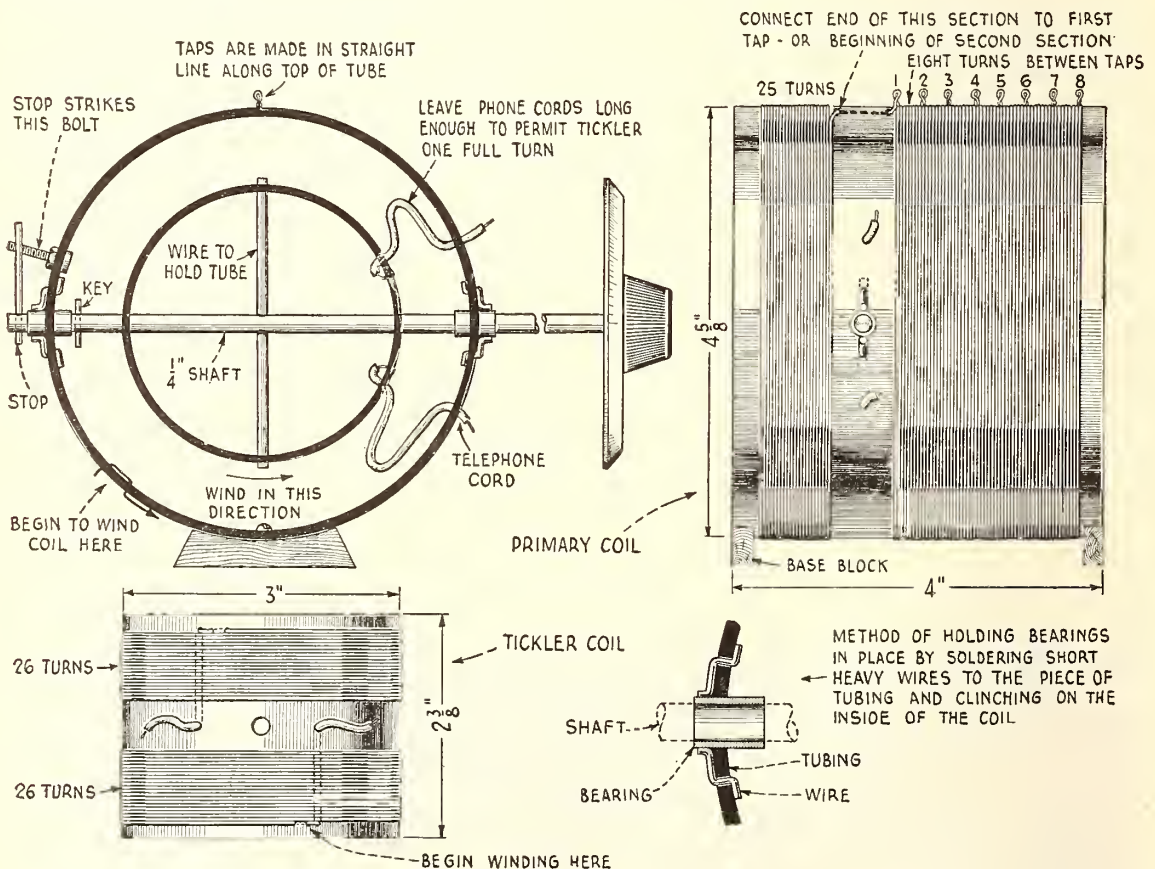

FIG. 1

Details of construction of the primary coil and the tickler



In regard to the construction of this set, you will be well repaid if you do the work in a neat manner, soldering connections throughout. Make connections as short as possible, especially to the grid and the parts which carry high-frequency current, such as the variocoupler.

#### MAKING THE VARIOCOUPLER PRIMARY

WE WILL begin with the construction of the variocoupler: Obtain a cardboard tube  $4\frac{5}{8}$ " in diameter and 4" long. Soak the tube in melted paraffin or apply shellac to prevent shrinking. Next punch or bore a hole in the tube  $1\frac{1}{2}$ " from the end. This hole should be the proper size to take a piece of brass or copper tubing  $\frac{3}{4}$ " long in which the shaft can be inserted. The method of inserting these bearings will be easily understood from the drawings. Half way around the tube and  $1\frac{1}{2}$ " from the end punch or bore another hole to take the other bearing.

Begin winding the coil with No. 23 single silk covered wire, as indicated on the drawings, about  $\frac{3}{8}$ " from the end of the tube. Run the end of the wire in and out of two pin holes to hold it and wind in the directions of the arrows. Wind on a section of 25 turns without a tap. Then run the wire along the tube  $\frac{3}{4}$ " to the beginning of the second section. A tap is then made (No. 1 in the drawing, Fig. 1). To make a tap twist the wire into a simple loop and continue winding. Wind the second section with eight complete turns. Then make a tap. Wind eight turns more and make a tap. Continue with the winding, making eight turns and then a tap until seven eight-turn sections have been made. The end of the last section acts as a final tap. Secure this end by running it through pin holes in the tube.

#### WINDING THE TICKLER COIL

WIND the tickler coil on the 3" tube, using the same size wire as on the primary coil (No. 23 S.S.C.) Run the end of the wire through two pin holes  $\frac{1}{4}$ " from the end of the tube, leaving about 2" for connection. Now

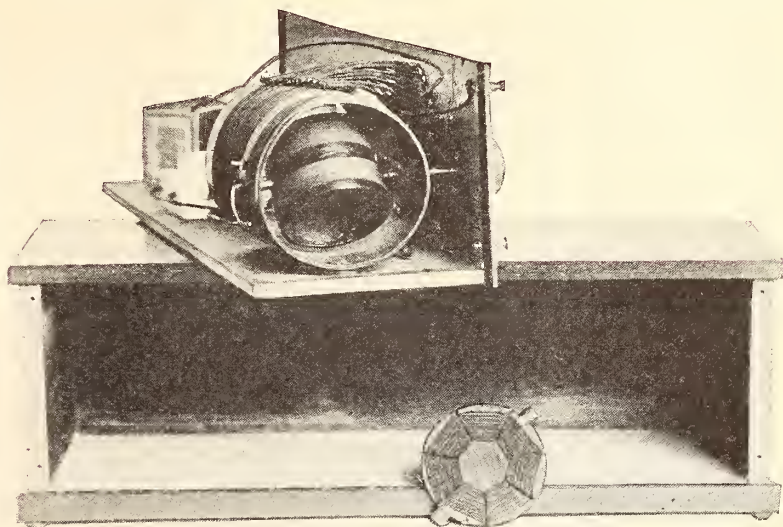

FIG. 2

The set and its cabinet. The spider-web coil shown in front of the cabinet may be used inside the primary coil instead of the cylindrical tickler

start winding in the direction of the arrow shown on the drawings. Wind on 26 turns. This forms the first section. Without cutting the wire, keep on winding diagonally across the space between the sections on the back of the tube. (This is shown by the dotted line in the drawing of the tickler coil.) Keep this wire well away from the holes for the shaft. The wire may be held in place by a drop or two of sealing wax. Then begin winding the second section, being careful to start this section the same distance from the centre of the tube as the last turn of the first section. Wind 26 turns and pass the end through two pin holes made in the tube. Leave about 2" for connecting. About 1" above the  $\frac{1}{4}$ " hole that the shaft passes through, bore a hole and insert a 4" piece of telephone cord or other wire that is quite flexible. This cord or other wire should be soldered to the 2" of wire (inside the tube) at the beginning of the winding. The telephone cord may be held by a drop of sealing wax where it passes through the tube. Bore a hole below the hole for the shaft and insert another piece of telephone cord. Solder this to the end of the second section.

#### THE SPIDER-WEB TICKLER

THERE is another tickler coil which is equally satisfactory, if properly constructed. That is the spider-web. If you want to use it, instead of the tickler coil just described, cut out a disc from cardboard which just clears the inside of the primary nicely. By cutting off the

shaft and slotting the ends with a hacksaw the coil may be held in place so as to rotate inside the primary. Cut any *odd* number of slots in the disc (I used 7—see Fig. 2), and wind the wire in and out through the slots until all the wire possible is wound on (about 40 turns). Connect the two ends to pieces of telephone cord. It will be found that this tickler will give more selective tuning on account of preventing

screws against the sides of the cabinet. This feature makes it very easy to remove the set from its cabinet. The panel is screwed to the edge of the base.

Place the variocoupler in position as close to the end of the base as possible so the tickler coil will clear the side of the cabinet when turned. Now slip the base blocks under the ends of the variocoupler and locate on the panel the hole for

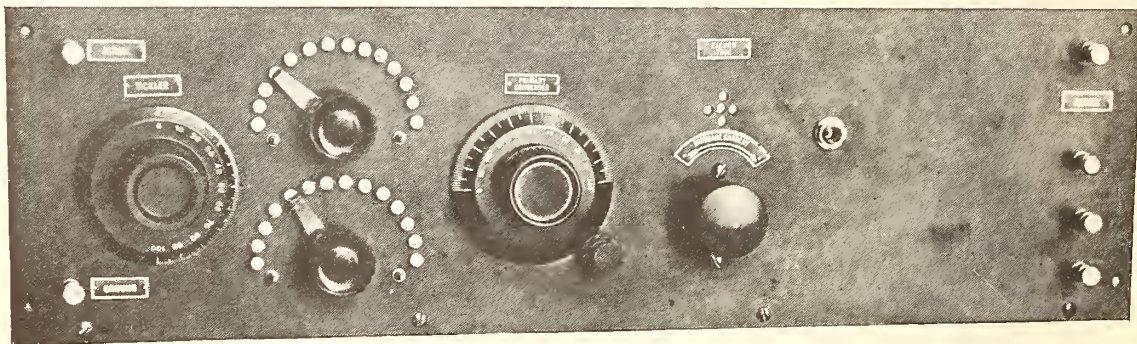

FIG. 3

A neat, attractive panel, with room at the right for the additional peep-holes, phone-jack and rheostat needed if a step of amplification is added

electrostatic coupling and increasing the electromagnetic coupling.

#### ASSEMBLING THE VARIOCOUPLER

THE shaft, which is about 7" long, has two small holes bored near the back end. The stop wire runs through one hole and strikes against a small bolt or switch point. A small key is inserted on the inside of the bearing to prevent the shaft from slipping endways. The tickler coil is secured by a small wire running through the shaft, the ends just passing through the tube.

First run the telephone cords attached to the tickler coil through two holes in the primary tube. One of these holes is above and the other below the bearing, or if preferred the cords may be held with a small bolt inserted in the holes. Next slip the shaft through the bearings and the tickler coil. Fasten the stop and pin in the holes at the end of the shaft, and secure the tickler coil by a small wire running through the tube and shaft. The variocoupler rests upon two small base blocks of wood or fiber.

#### ASSEMBLING THE SET

OBTAIN a board for the base about 8" wide and  $\frac{3}{8}$ " thick. Cut to a length that will just nicely slide into the cabinet. This board is somewhat shorter than the panel, as the panel

the shaft turning the tickler. The hole for the shaft of the variable condenser should be on a line with that of the tickler and the two shafts about 6" apart. The dials are about 3" in diameter. Unscrew the panel from the base. Bore the holes for tickler and condenser shafts. Centre the two inductance switches and bore the holes. Bore eight holes for each row of switch points so that the heads of the switch points will not be too far from each other for the switch lever to pass smoothly over them. Bore also the holes for the switch stops. The small knob at the lower right of the condenser dial in the photograph (Fig. 3) is a homemade friction vernier attachment made from a binding post cap and a short piece of threaded shaft. A rubber disc rubs on the edge of the dial. This is almost a necessity unless one has a vernier condenser, as very sharp tuning is required. Bore the holes for the rheostat next, placing it as near to the condenser as possible without interference. The phone jack is optional but is necessary for a stage of amplification. Bore the holes for the six binding posts: aerial, ground, phones and A battery. The phone condenser is of the paper and tinfoil type. Mica and copper are considered a better combination but this type has worked satisfactorily for me.

Glue tinfoil on the back of the panel to act as a shield for body capacity. This runs just as



far as the rheostat. Cut the tinfoil away from all metal shafts and rows of switch points by a margin of at least  $\frac{1}{8}$ ". Also cut it from around the aerial binding post, but do not cut it away from the ground binding post as it must make contact with the ground. Shielding must be done carefully, for if the tinfoil touches a shaft or screw the set may fail to operate.

After this is done, screw the switch points in and put in the inductance switches. Run a wire from the ground binding post to the upper inductance switch and solder it. Bare wire covered with rubber tubing or spaghetti may be used throughout. The wire used in this set is No. 18 covered with black cotton. Cut eight pieces of wire about eight inches long. Take one of these and solder one end to the first switch point in the lower row. Run this wire up to the first switch point in the upper row. Leave about five inches for connection to the first tap on the variocoupler. Connect up the two rows of switch points in this manner. The second switch point in the upper row connects to the second in the lower row. Solder one end of a wire to the lower inductance switch and leave the wire long enough to reach the lower binding post at the right of the panel.

The panel may now be mounted on the base board. Place the variocoupler on the base board with the shaft through the hole in the panel and with the dial attached move the variocoupler until it rests level and square with the panel. Fasten it to the base with wood screws running through the base blocks. Solder the wires from the upper row of switch points to the taps in the coil, the first switch point to the first tap, etc.

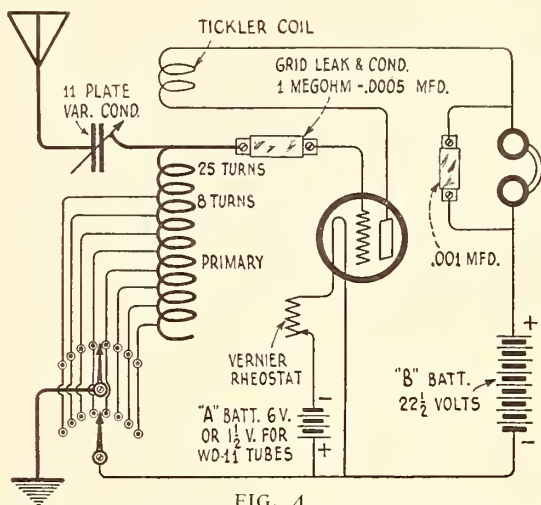

FIG. 4

This single-circuit regenerative hook-up is about the simplest tube hook-up there is. It is *not* recommended in thickly-populated districts, because it causes interference by re-radiation; but it is very efficient and just the thing for the person who lives in the country and hasn't much to spend on a set

Connect the aerial binding post to the rotary plates of the variable condenser. Run a wire from the stationary plates of the variable condenser to the beginning of the primary winding. Connect the plate terminal of the vacuum tube socket to the lower terminal of the tickler coil. Run a wire from the upper binding post and phone condenser over to the upper terminal of the tickler coil. Connect the wire soldered to the lower inductance switch to the lower right hand binding post which will be a positive A battery terminal. Connect the positive ("plus") terminal of the socket to this wire. Run a wire from the negative side of the socket

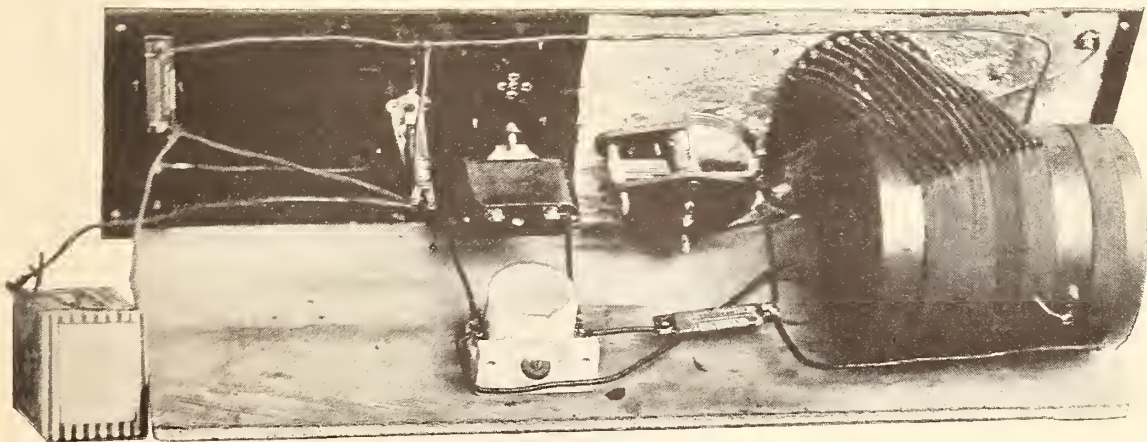

FIG. 5

Mr. Nelem purposely made his panel 21 inches long, so that he could add a step of audio-frequency amplification when he wanted to

to the rheostat and one from the rheostat to the negative A battery binding post, which is second from the bottom. The negative pole of the B battery connects on the positive A or bottom post. The positive B goes to the phone condenser. The grid leak and condenser connect to the beginning of the primary winding. Constant reference to the three photographs and the diagrams should enable any one who follows these instructions carefully to build a set like mine without difficulty.

#### OPERATION OF THE SET

**W**HEN tuning in a broadcasting station set the inductance switches on about the fourth points (with a hundred-foot aerial). Turn on the rheostat until the bulb starts to hiss. Then, with the tickler coil lying horizontally, turn the variable condenser around slowly being careful not to pass over the signals. If this does not bring in signals, turn the tickler coil half way over and try again. It will be found that the condenser will be used most in tuning. When the condenser is at zero capacity a very loud howl will be heard in the phones. The use of the vernier rheostat must not be slighted, however, as this will give clearness of tone and help to prevent howling. Do not

turn the rheostat on too far. If the grid leak is of the right resistance, a sharp click will be noticed when turning on the rheostat. Keep the filament current just below this click to get the strongest and clearest signal.

I have used the electric light wiring in the house for an aerial and find that it is almost as good as my outside aerial which is about 100 feet long and 30 feet high. With one stage of audio-frequency amplification I have heard stations in Los Angeles (from my home in East Tawas, Michigan) using the light wires as an aerial and the bed springs as a counterpoise. Using the light wires as an aerial, I have connected one wire to either the centre or side contact in the electric-light socket and run this wire to the set, turning on the switch in the lamp socket. The variable condenser stops any current from passing into the set. By connecting the ground to the aerial binding post I have heard stations 500 miles distant.\*

One stage of amplification can very easily be added at the right of the detector tube. It was with the idea of this addition that the panel was made 21 inches long.

\*Mr. Nelem's total mileage is 61,100—92 stations over 150 miles distant, of which four were 2000 miles or over.

## A Set With a Tuned R. F. Amplifier

A Non-Regenerative Outfit Designed Primarily for Quality, Not Quantity

By J. W. DENNING

(HONORABLE MENTION)

**W**HEN a radio fan's craving for distance and innumerable new stations is satisfied—as it always is sooner or later—he begins to

study methods of improving the quality of what he receives and the stability of his set. The single-tube set which he usually starts with does not satisfy him, and he begins to tack on more tubes and try all sorts of hook-ups. Certain stations become old friends to him—he tunes in on them regularly and often listens to them until they sign off. The advantages of a set

giving good quality of reproduction, plenty of volume, and which does not require continual manipulation to keep it in tune, soon become apparent to him.

The writer some time ago found himself converted to this attitude, and the receiver herein described is a result of considerable study on the matter. It was early recognized that regeneration, while able to cover great distances and with proper amplification giving good volume, at its best was unstable and tended to distort. R. F. amplification seemed to offer a way out of these difficulties.

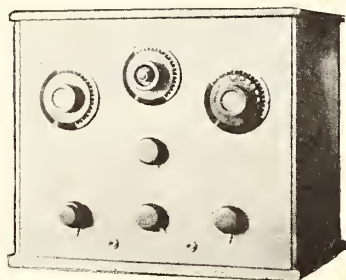

THE "QUALITY FIRST" BOX  
It has 4 tubes, no regeneration



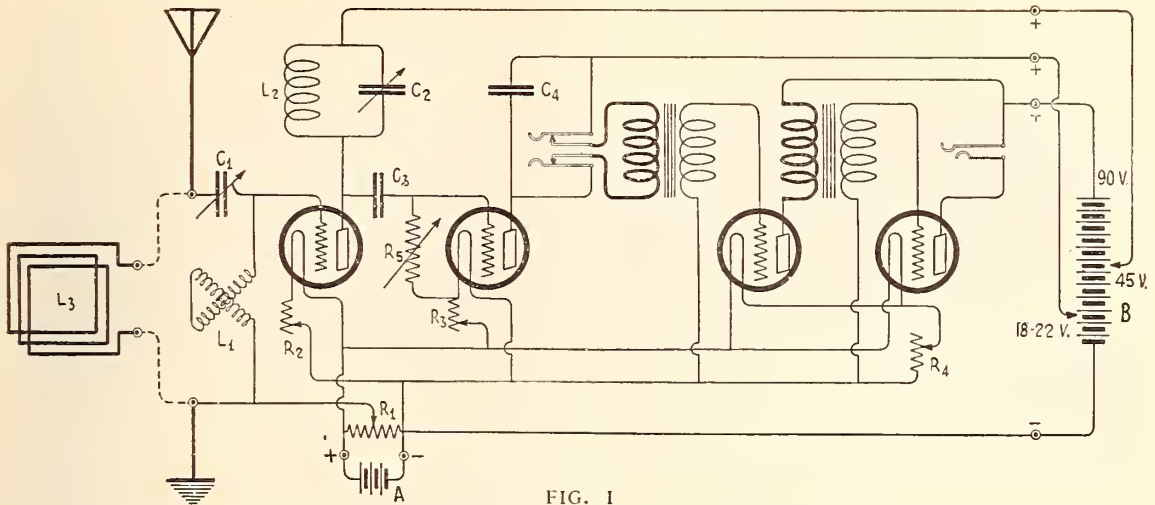

FIG. 1

The grounded side of condenser  $C_1$  is the rotar. A plug and jack arrangement, or a double-pole double-throw switch, may be used to advantage for quickly changing from antenna and ground to the loop,  $L_3$

All the available commercial R. F. sets were carefully studied and various R. F. transformers experimented with as they came on the market. It was found that, while several untuned types of transformers worked very satisfactorily they required a highly selective tuner with rather loose coupling. Since loose coupling meant a reduction of transferred energy, a method of obtaining selective tuning with a single-circuit aerial tuner was sought, and found in the tuned transformer and tuned impedance methods of radio-frequency amplification. The latter method was adopted as being simpler than the tuned transformer and equally efficient. An added feature was its adaptability to any type of tube, which was not the case with transformers, making it possible to use dry-cell tubes when so desired. The set illustrated is one of a number constructed on this principle, all of which have given entire satisfaction.

Referring to the circuit diagram, the principal constants are as follows:

$L_1$ —A well built variometer with a fairly large range of inductance to cover a wide band of wavelengths.

$L_2$ —A honeycomb coil of 35, 50, or 75 turns, set so that it will not be too closely coupled inductively to  $L_1$ .

$L_3$ —Loop aerial for "static nights", 10 to 12 turns, flat wound, two feet on a side. It may be used with the outside aerial as indicated.

$C_1$ —11-plate variable condenser, giving fine tuning in aerial circuit. Note: a series-parallel switch will increase the wavelength range of this set very much when used with this condenser and  $L_1$ .

$C_2$ —23-plate variable condenser, preferably with vernier, used to tune  $L_2$  to resonance with the grid circuit.

$C_3$ —Fixed grid condenser of from .00025 mfd. to .0005 mfd. It should be a good mica condenser.

$C_4$ —Fixed phone by-pass condenser, capacity .001 mfd.

$R_1$ —200- to 400-ohm potentiometer, used to control regenerative tendency of amplifier tube and prevent oscillations.

$R_2, R_4$ —6- to 25-ohm rheostats, depending on tubes used.

$R_3$ —6-ohm rheostat for detector filament. Vernier helps if detector is soft.

$R_5$ — $\frac{1}{2}$  to 5 megohms. This is the grid leak for the detector tube and is preferably a good variable leak.

The tubes recommended for best results are as follows:

Detector: soft tube such as UV-200.

A. F. Amplifiers: Hard tubes such as UV-201 or 201-A, or De Forest.

R. F. Amplifier: Hard tube such as UV-201 or 201-A. The 201 seems to work as well as, if not better than the 201-A.

WD-11, WD-12, or UV-199 tubes may be used if desired, although they are not as good amplifiers as the above mentioned tubes.

It will be noted that a separate plate lead is brought out for the radio-frequency tube. It

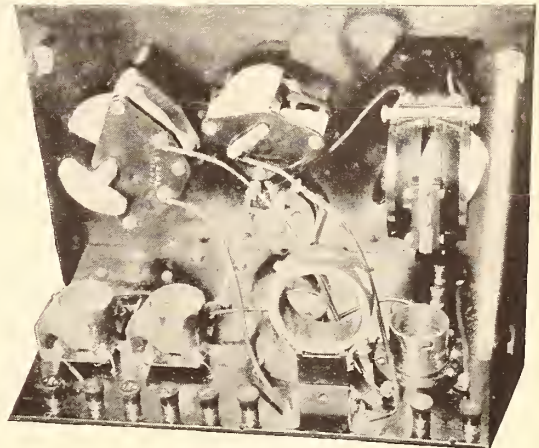

FIG. 2

Showing relative positions of the various units

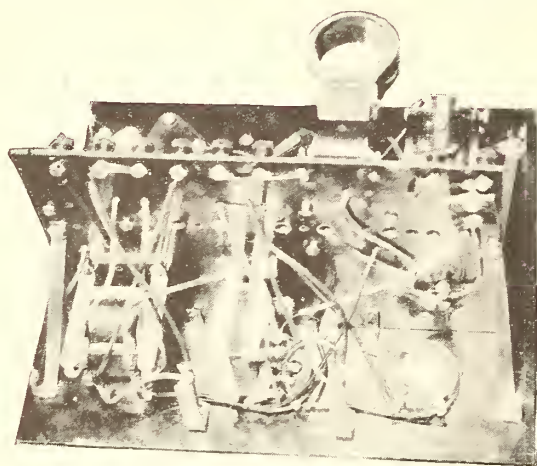

FIG. 3

The set of Fig. 2 has been tipped back, to show the transformers, mounted under the shelf which is fastened in back of the panel

will be found that this tube will operate best at a lower voltage than the A. F. tubes. A. F. transformer filament leads should be connected to the negative of the A battery with the rheostat in the negative lead to the sockets. The grid leak should run to the positive terminal on the detector socket.

#### TUNING

THE principle involved is this: when the grid circuit and plate circuit are both in tune with the incoming signal only the signal

tuned to will be amplified, all others "falling by the wayside." It is important that the distributed capacity in  $L_1$  and  $L_2$  be low, thus giving the sharpness of tuning which is so much desired. By setting the potentiometer as near the negative as possible without starting oscillations and moving  $L_1$  and  $C_2$  simultaneously, the corresponding resonance positions will soon be found and stations easily tuned in. Fine tuning is done with  $C_1$  and the vernier on  $C_2$ . This set will usually operate best with low values of  $C_1$ , on the outside aerial, and medium values when used with the loop. (This can be accomplished by careful adjustment of the variometer.) Careful setting of  $R_1$  makes for maximum amplification. It should be turned as far to the negative side as possible without producing oscillations. Oscillations are manifested by the set suddenly "going dead," an effect which can be easily identified. When oscillating, it makes a very good receiver of undamped waves. Since phone signals cannot be received when the set is oscillating, there is no inclination to use it in the oscillating condition on broadcast reception, hence it does not cause interference as regenerative sets often do.

Although the writer isn't much of a "radio golfer," some of his friends have made very creditable records in an evening with the set just described. The total mileage is 71,125, with 89 stations logged, the farthest (from Boulder, Colorado) being PWX in Havana.

## A Home-Made Three-Tube Outfit

It is Easy to Build and Easy to Operate. It Has Brought in 100 Stations, Two of Them Being 2000 Miles from the Writer's Home in Marion, Indiana

By L. REITH

(HONORABLE MENTION)

THIS set is made up of three parts—tuner, detector, and two stage amplifier. It is very efficient and selective, easy to tune and works equally well on all wavelengths from 150 to 700. It works better than several other sets I have made, running from single circuits to the variometer and variocoupler hook-up, and has given excellent results from the very first minute it was tested out.

The tuner circuit is composed of a stationary primary coil, movable secondary coil in

inductive relation to the primary, a stationary secondary loading coil in series with the secondary, a movable tickler coil in the secondary loading coil, and a 23-plate variable condenser.

For the primary coil, wind 65 turns on a tube  $3\frac{1}{2}$ " in diameter and  $2\frac{1}{4}$ " long, tapping at turns 15, 18, 21, 24, 27, 30, 35, 40, 45, 50, 55, 60 and 65, making 13 taps.

The secondary loading coil is wound with 38 turns on a tube  $3\frac{1}{2}$ " in diameter and  $1\frac{3}{4}$ " long, tapping the tenth and the last turns.



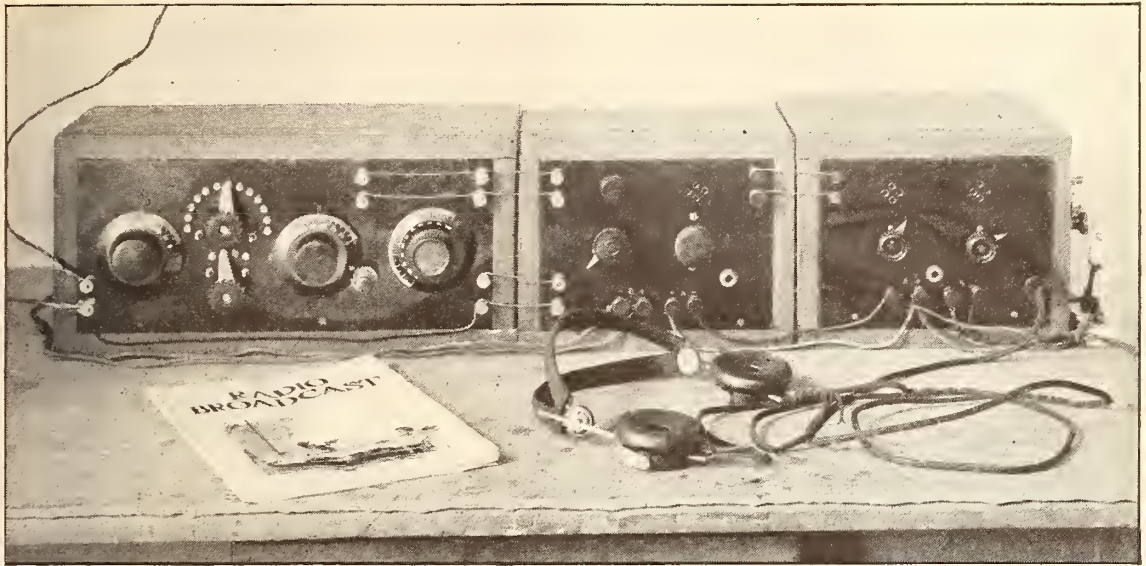

THE OUTFIT COMPLETE, AND READY TO FURNISH AN EVENING'S ENTERTAINMENT

In the left-hand cabinet are the tuning units only, in the middle one is the detector, and in the right-hand cabinet are the two steps of A. F. amplification

These two coils are mounted on the panel at right angles as shown in one of the photos, with small brass angles or pillars so as to set them back  $\frac{1}{4}$ " from the panel.

The secondary and tickler coils are exactly alike, being 3" in diameter and  $1\frac{1}{4}$ " long, wound in two sections, each  $\frac{3}{8}$ " long, with a space of  $\frac{3}{8}$ " between to allow for the shaft. The shafts are made of  $\frac{3}{16}$ " brass rod 5" long, threaded on one end for about one inch, and from the other end up to the thickness of the panel from the first threads. This small place left is for

the bearing on the panel. If this bearing is carefully made, no rear support for the shaft will be needed. It is a good plan to use a panel bushing such as those on switches, but if these are not at hand, screw on the short threaded end of the shaft a nut as tight as it will go, put the shaft through the hole in the panel (be sure that it is not a bit larger than necessary for the rod to slip through) and put two nuts on the other side of the panel, using the last one as a lock-nut. Get them close enough to the panel to make a good bearing for the shaft. It is well

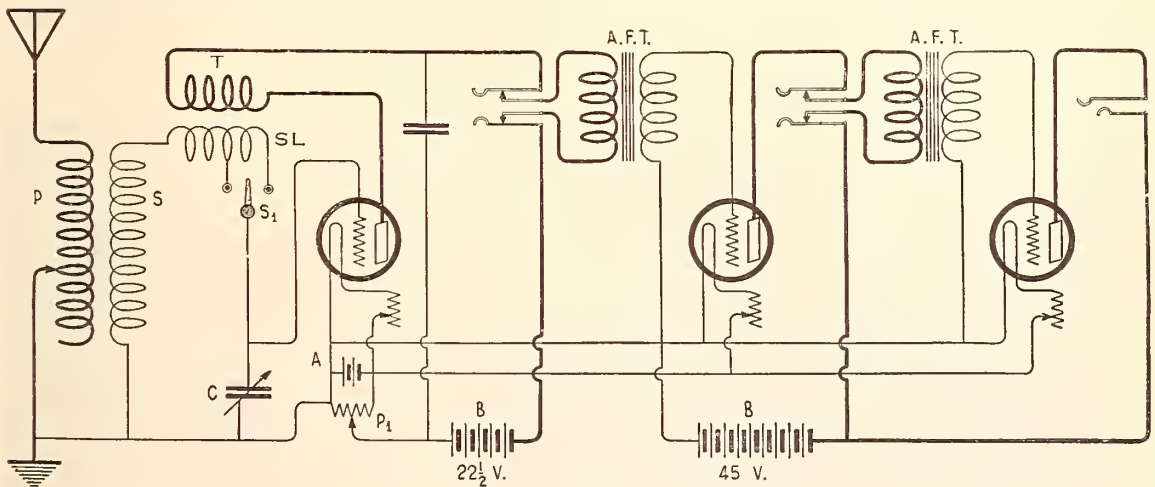

FIG. 1

P-primary coil, S-secondary coil, SL-secondary loading coil, T-tickler, S<sub>1</sub>-switch for cutting in inductance, C-23-plate condenser with rotor grounded, P<sub>1</sub>-potentiometer

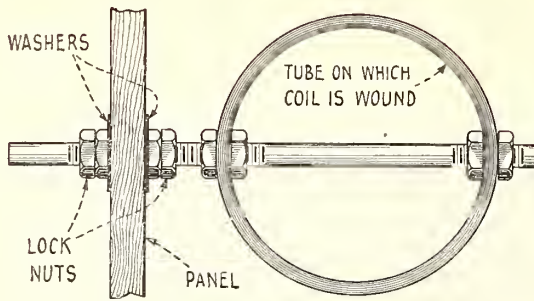

FIG. 2  
Showing bearing for movable coils

to include washers next to the panel on both sides. Then put on the coil, using a nut on each side of the tube at both places where it goes over the shaft to hold it in place. These should be placed to hold the coil in the right position for turning without touching the larger coils. Run leads from the coils to their proper connecting places. All winding was done with 20-strand No. 38 Litzendraht.

The detector and amplifier are of standard construction and hook-up. The list of materials needed for this set is as follows:

- 1 tube,  $3\frac{1}{2}$ " dia. and  $2\frac{1}{4}$ " long
- 1 "  $3\frac{1}{2}$ " "  $1\frac{1}{4}$ " "
- 2 "  $3$ " "  $1\frac{1}{4}$ " "
- 2 brass rods,  $\frac{3}{16}$ " x  $5$ "
- 2 switch levers
- 1 23-plate variable condenser
- 3  $3$ " dials
- 1 potentiometer
- 1 Bradleystat
- 2 rheostats
- 3 sockets
- 2 two-circuit jacks
- 1 one-circuit "
- 2 amplifying transformers
- 1 .001 mfd. fixed condenser
- 1 grid leak and condenser
- 200 ft. 20 No. 38 Litzendraht

Connecting wire  
Switch points  
Binding posts  
Panels  
Miscellaneous bolts and nuts

#### INSTRUCTIONS FOR OPERATING

USING dials with a 90-degree scale, 0-50, set so that they are at 0 with both coils in a vertical position. Then proceed as follows:

Set the secondary dial at about 40 and the tickler dial at about the same. These will be approximately the best positions for these dials on all wavelengths. Then set the switches on taps best for the particular wave wanted; for example, for 360 or 400 meters, put the primary on tap 7 and the secondary on tap 2. The best positions for these will be easily found after a little experimenting. Turn the rheostats up until oscillation just begins, and move the condenser dial until you get a carrier-wave squeal. Tune as well as possible with this and finish tuning with the secondary dial, as this acts as a vernier on the condenser and will give very fine tuning. Adjust the tickler so that the signals are loudest without distortion. Waves up to 300 meters come in best in my case with the secondary switch on tap 1; over 300, on tap 2.

On the end of the amplifier box are a switch and binding posts for connection to a loud-speaker if wanted, so that either it or the phones or both, may be used.

A good loud speaker can be made by getting an old-style phonograph horn and soldering on it a bracket and a plate or can lid large enough to take a receiver and with a hole just the size of the neck on the horn. Put a piece of felt on this and clamp the receiver on with rubber bands or any kind of clamping device.

#### THE OUTFIT OPEN FOR INSPECTION





# Summary of Receiving Contest Entries Arranged in Order of Mileages

*The following report includes the work of all contestants having a total mileage of 40,000 or over, but does not include the Prize Winners or Honorable Mentions:*

JOHN C. Peters, Casper, Wyoming. 305,420 miles. His receiver employs the principle of "resistance neutralization" developed by his brother, Leo J. Peters, Radio Research Engineer for the University of Wisconsin. For information regarding this principle, Mr. Peters refers us to the *Journal of the A.I.E.E.*, Vol. 41, March, 1922.

Otho Currie, 3305 Avenue H, Fort Worth, Texas. 283,330 miles. One-tube single-circuit regenerator. He has heard every state in the U. S., 10 stations in Canada, 1 in Porto Rico, 2 in Hawaii, 1 in Alaska, and 1 in Cuba.

Milton S. Johnson, 938 So. 4th St., Atchison, Kansas. 199,988 miles. 3-circuit set using one step of radio, detector, and one audio. He comments on the "great feeling, to be able, any ordinary evening, to slip your phones on your ears and listen to any one of the better class broadcasting stations in the United States." However, he remarks: "I have made one discovery and that is that the real fun in radio is to have a C.W. and 'fone' transmitter, belong to the A.R.R.L., and talk back and forth to China and London." Yes, we have no objections.

Leland K. Hill, Wellsville, Utah. 179,588 miles. Single-circuit regenerative set with a two-stage home-made amplifier. During the cold weather nights he has stayed up into the small hours and heard a number of 2000-mile stations, the farthest being Halifax, Nova Scotia, 2490 miles from Wellsville.

Captain J. H. Halsey, skipper of the S. S. *El Cid*, which runs between New York and Galveston, Texas, made his own 3-tube outfit in conjunction with a friend. 172,960 miles. "We average eighteen nights a month at sea," he writes, "where we have a very clear atmosphere. The antenna runs from masthead to masthead, above the ship's antenna, and direct to my cabin. The set is surely good company."

Fergus Sunshine McKeever (age 12), University Heights, Lawrence, Kansas. 170,000 miles. Grebe CR-9 (three-tube regenerative set), with Baldwin phones and a W.E. loud speaker. This youthful contestant has "listened as late as three o'clock getting 65 stations in one evening." He claims to have heard a station in Portugal, one fine winter's night.

Arthur Chapelle, Woodburn, Ore. 168,690 miles. Three-circuit, tickler regenerative set, two tubes. Mr. Chapelle sent us one of the excellent spider-web coils which he makes himself, and to which he ascribes much of his success in pulling in far-away stations.

E. Woody Kulman, 1046 36th St., Des Moines, Iowa. 148,255 miles. His home-made receiver, of the standard single-circuit type, cost him \$37.40. He observes that Des Moines has a conveniently central location for reception from all points of the compass.

J. B. Slaughter, Jr., U Lazy 9 Ranch, Post, Texas. 147,680 miles. He has heard 203 different stations, all on a 3-tube set with a Magnavox R loud speaker. "Radio on the ranch," says Mr. Slaughter, "is the greatest invention yet, for ranchers, as a rule, are a great distance from any entertainment or late news of any sort; with the coming of radio we are right alongside the large cities. We get the baseball results, for instance, even before they do, unless they have radio sets installed. The broadcasting of cattle and crop quotations is very valuable on ranches, as we can tell better when to ship our cattle and grain. Any one ever in this part of the country is extended a cordial invitation to visit the ranch and see my set."

T. W. Sharpe, Jr., (age 15), 1816 North Colorado St., San Antonio, Texas. 147,325 miles. Detector and two of audio again, with an improvised loud speaker to which the headphones are attached.

W. E. Davison, 538 Charlotte St., Sydney, Nova Scotia. He has tried many circuits but finally settled on the common or garden variety of single-circuit regenerative hook-up, which, it is to be hoped, causes less interference in Nova Scotia than it does in other places we might mention.

Robert Allen, Mendota, Ill. Amateur 9CTF. 133,011 miles. A Grebe CR-8 receiver with a three-stage audio amplifier. Mr. Allen says: "This set with one tube, no R.F., has picked up KFI on a three-foot loop, and I believe that this is something worth while trying to duplicate. I base the success of my outfit on the aerial that I have, which is 305 feet long suspended between two trees. The ground consists of three 6-ft. pipes driven in moist earth."

A. T. Hull, Jr., 318 Armistead Avenue, Hampton, Va. 123,470 miles. "Down by the sea in Hampton, Va., radio has full swing. Coming home this evening I counted four aeriels within 100 yards of my house." Single-circuit outfit, with two stages of audio.

Theodore Nelson, 1451 Thomas St., St. Paul, Minn. 122,320 miles. Three-circuit, single-tube, with plate variometer.

Alvin J. Meyers, 69 New St., Blue Island, Ill. 119,223 miles. Home-made three-tube outfit.

W. Hall Moss, Dayton, Tenn. 115,155 miles. Three-circuit set, home-made.

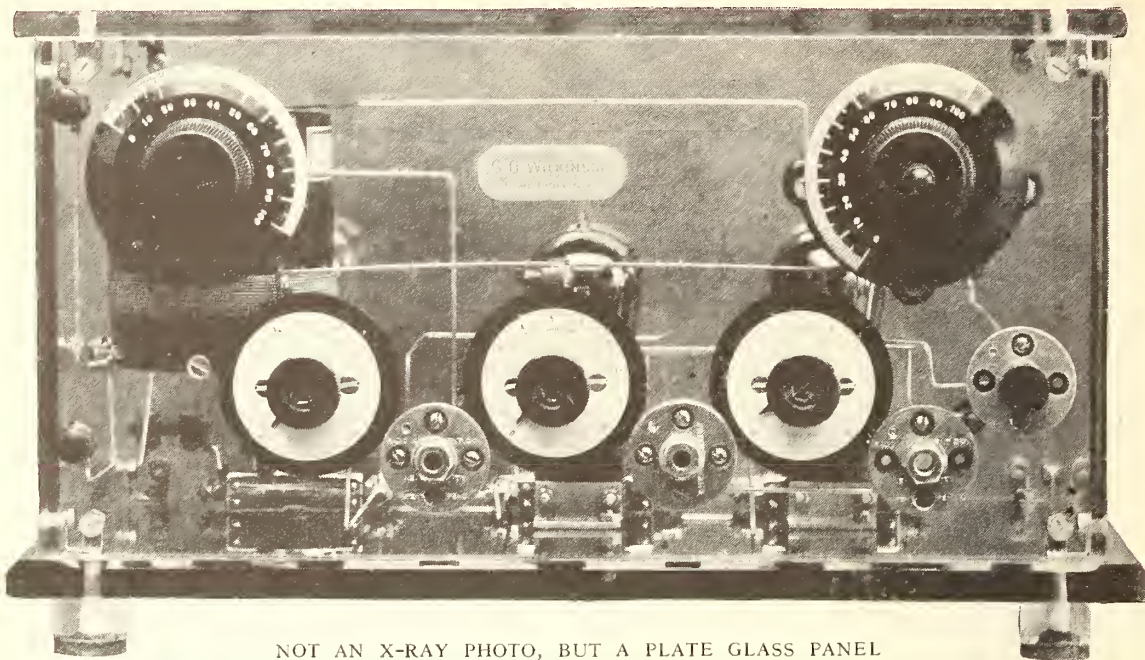

NOT AN X-RAY PHOTO, BUT A PLATE GLASS PANEL

The set is the work of G. O. Wilkinson of Philadelphia, Pa. The "Home-Built" Coil, which he manufactures, is an important part of this set. One of them is seen behind the upper left-hand dial

## Various Sorts and Sizes, All Home-Made

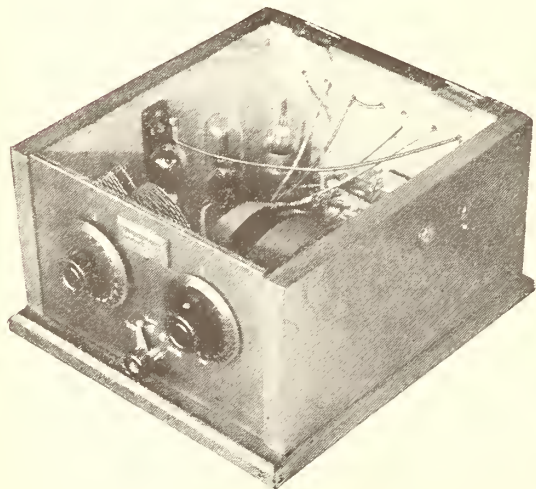

A 3-TUBE SET IN A SMALL SPACE

It was built by William J. MacChesney of Summit, N. J. The switch between the two dials turns on and off the filaments, at the same time changing the number of turns of the primary coil



GEORGE WOODRUFF, OF WINCHESTER, VA.  
With the single-circuit outfit he made

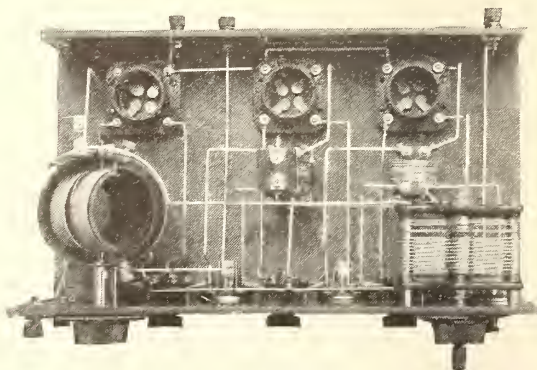

A NEAT JOB, DON'T YOU THINK?  
Another view of Mr. Wilkinson's receiver



J. H. Taylor (age 13), 1434 Meridian Pl. N.W., Washington, D. C.. 110,021 miles. Home-made single-circuit regenerator, plus two stages of audio.

Three-wire antenna 55 feet long and 50 feet high. H. S. Fredrickson, 406 Howard St., Charles City, Iowa. 109,500 miles. 170 different stations, of which 121 were heard on one tube (single-circuit).

Lester Witherby, in care of W. B. McClure, 263 E. 43rd St., Seattle, Wash. 108,122 miles. See July, 1923, RADIO BROADCAST, page 236.

Edward A. Block, 1805 Peabody Ave., Dallas, Texas. 104,605 miles. Reinartz circuit.

Albert Hiller, Jr., 701 N. 39th St., Philadelphia, Pa. 104,230 miles. Two radio, detector, and two audio, home-made.

George Kingston, 722 First St., Fort Meyers, Fla. 103,180 miles. A De Forest D-7 reflex loop receiver, used with a three-foot loop *and* outdoor antenna *and* ground. During parts of February and March, Mr. Kingston heard Los Angeles almost every night. One night he pulled in four stations on the West Coast.

Cecil Newton, Webster, N. Y. 101,665 miles. Home-made single-tube set. Says Mr. Newton: "I think, of all the evenings of enjoyment I ever had the first evening with my set was the best. 'Ain't it a grand and glorious feeling when you have accomplished something that works.'"

Thomas Mahoney, 1900 Crockett St., Dallas, Texas. 100,600 miles. Reinartz tuner, home-made with two stages of audio.

Edward M. Starkey, Le Sueur, Minn. 99,675 miles.

Fred R. Nicholls, Cle Elum, Wash. 107 stations on his home-made Reinartz and two audio equipment.

L. W. Carlisle, Lisbon, N. D. 96,673 miles. Aeriola Sr. with one stage of home-made audio-frequency amplification. He got WJZ (1300 miles from Lisbon) on May 5th, after trying all winter.

Elmer Gruneske, 1282 W. 106th St., Cleveland, Ohio. 95,485 miles. Westinghouse RC and two steps.

Joseph Gretter, Grandin, N. D. 94,387 miles. One-tube, single-circuit home-made.

Roscoe Robinson (age 14), Ponca City, Okla. 93,475 miles. See page 237, RADIO BROADCAST for July, 1923.

George W. Miller, Box 293, Manitou, Colorado. 91,420 miles. Three-circuit regenerator with two stages of audio. Mr. Miller has received voice from coast to coast and from the Gulf to the north of Canada. He mentions that from his home in Colorado he has also brought in code from distant points at sea and from Germany.

Harold D. Smith, Box 131, Ducor, Calif. 90,055 miles.

Daniel Lamb, 229 West 1st St., Mesa, Ariz. 88,795 miles. See page 238 in July issue.

Edgar I. Eisenstadt, Highland Park, Ill. 87,840 miles.

W. S. Neely, Chester, S. C. 85,509 miles.

Alvin Rasmussen, Box 503, Chinook, Montana. 85,185 miles.

A. J. Master, Highgate, Ontario, Canada. 84,965 miles.

Wm. J. MacChesney, 34 Hawthorne Place, Summit, N. J. 84,100 miles.

Henry Duderstadt, 6041 Main St., Kansas City, Mo. 81,040 miles. See page 238 in July issue.

G. O. Wilkinson, 417 Walnut St., Philadelphia, Pa. 79,985 miles. Photos of his set are published in this issue, page 490. He sent us a sample of the well-made "Home-Built" tuning coil which he manufactures.

W. E. Dougherty, Box 44, Ault, Colo. 78,405 miles.

L. J. Love, Warrensburgh, N. Y. 78,015 miles.

Wesley Thomas, Little Falls, N. J. 77,550 miles.

Lloyd Saxon, Box 214, Clovis, Calif. 77,324 miles.

Robert R. Taylor, Prospect Ave., Willow Grove, Pa. 74,505 miles. He has logged Los Angeles 13 times, San Francisco once, Calgary once, and Denver 3 times. Grebe CR-5 and Sleeper two-stage amplifier.

Dwight V. Johnson, Box 242, Ludington, Mich. 71,965 miles all on loud speaker. Three-circuit, single-tube twin-variometer set. In tests aboard a steamer on Lake Michigan, Mr. Johnson brought in KFI and KHJ on two successive nights, so loud that their programs could be heard all over the ship's cabin.

Curtis Herbert, 185 Montrose Ave., Rutherford, N. J. 69,501 miles. See page 238, July RADIO BROADCAST.

Bruce MacDonald, 1817 E. 3rd St., Duluth, Minn. 69,175 miles.

Stephen Carleton Rogers, 21 Red Rock St., Lynn, Mass. 68,755 miles.

Jack Ryder, 1100 Westwood Ave., Columbus, Ohio. 67,920 miles.

Howard H. Weston, Palisade, Colo. 65,850 miles.

George O. St. Charles, 408 Lincoln Avenue, Wayne, Mich. 65,188 miles.

W. F. Delp, Rural Retreat, Va. 63,939 miles.

Edwin M. Nisson, Radio 9EAM, 2544 Washington St., Denver, Colo. 63,780 miles. See page 238 July RADIO BROADCAST.

Ted Lehman, 520 W. Greenup Ave., Ashland, Ky. 62,915 miles.

Q. Scott, Aurora, Nebr. 60,903 miles

R. P. Mc Elhiney, Madison, Me. 59,840 miles. See page 238, July RADIO BROADCAST.

Leo M. Dilley, Sunfield, Mich. 59,391 miles.

Arthur Weld, Radio 9DHH, Cleveland, N. D. 58,795 miles.

Jonathan Eldridge, Jr. (age 14), Chatham, Mass. 58,585 miles.

Sten Anderson, 3247 Q St., Lincoln, Nebr. 58,480 miles.

Rolland R. La Pelle, Takoma Park, Washington,

D. C. 56,905 miles. See page 238, July RADIO BROADCAST.

Wilbur S. Nay, 415 16th St., Manhattan, Kansas. 55,931 miles.

Gerard Curtiss, Wauwatosa, Wis. 54,765 miles.  
Robert Selby, 1014 Bacon St., Pekin, Ill. 52,651 miles.

J. H. L. Fincke, 511 Elliott St., Evansville, Ind. 52,040 miles. See photo, page 418.

E. D. Harrington, 2331 Blake St., Berkeley, Calif. 51,974 miles. See page 234, July RADIO BROADCAST.

M. A. Jaeger, Englewood, Colo. 51,525 miles.  
Sam Terranella, 1101 Preston St., Dallas, Texas. 51,370 miles.

Harry B. Davenport, 1631 N. 61st St., West Philadelphia, Pa. 50,758 miles.

H. Wilbur Polson, Geneseo, Ill. 50,600 miles.  
Louis I. Roland, U. S. Navy Radio Station (NPL), Point Loma, Calif. 47,800 miles.

Fred and Albert Yohn, Norwalk, Conn. 47,748 miles.

William S. Best, in care of Washburn, Crosby Co., Minneapolis, Minn. 47,046 miles.

A. W. Bothwell, 2921 P St., Lincoln, Nebr. 44,400 miles.

James W. Brennan, 36 Front St., Beverly, Mass. 44,220 miles.

Don Ross, 123 Hibbert St., Ironwood, Mich. 44,040 miles. See photo, page 238, July RADIO BROADCAST.

Arthur H. Phillips, 297 Victor St., Winnipeg, Manitoba. 43,825 miles.

John D. Wylie, Lancaster, S. C. 43,517 miles. Mr. Wylie says: "I am sure that mine is no record, but when one considers that I am too deaf to hear a loud speaker, a conversation, a sermon, the tick of a clock (except at PWX in Havana, Cuba), or a telephone ring, I think it is truly wonderful that I have been able, alone, to tune in so many stations, hear the call letters and announcements clearly, and then the programs, with a pair of ear phones, using an RC set consisting of a detector and two stages of amplification. The radio is a joy to the deaf. I did not realize before I bought my radio that music sounded so sweet."

W. R. Bradford, *The North American*, Philadelphia, Pa. 43,320 miles. One of the drawings that Cartoonist Bradford sent in with his entry is reproduced on page 493.

Franklin S. Bradfield, Lawrence, Mich. 43,160 miles.

John H. Dixon, Plant Engineer at Station VMG, Apia, Samoa. 41,225 miles. This is interesting—Mr. Dixon lists only 9 stations, but none of them is under 4290 miles from his receiving set! Seven of them are California stations, and the other two are in Kansas City, 5460, and Davenport, Iowa, 5735! His letter left Samoa on April 10th, before he knew of this receiving contest. Explanation follows:

Radio Station  
Apia, Samoa.  
April 10th, 1923.

THE EDITOR,  
RADIO BROADCAST,  
DEAR SIR,

Now that your "How Far Have You Heard on One Tube?" Contest is finished, perhaps you will be having another for two tubes. To start it, if so, I send the following, all well over 4200 miles from Apia. To eliminate any stray references to "fish yarns" I include proofs of reception in every case. In regard to the reception from KFI, the speech comes in so well that if the announcer was to speak slow enough to enable me to write his remarks down, I could do so without error at least four nights a week all the year round. I'd do it oftener, but Old Man Static lives here.

All these stations are received on an amateur aerial swung between two California pine trees. The trees have been imported and are about the only ones of their kind in Samoa. Perhaps they like music from home.

The circuit I am using is an adaptation of the super-regenerative using two valves. I can get the same results with a five-valve receiver using three stages of radio-frequency amplification (tuned transformer). Both sets are home-made.

### COMMENTS ON THE CONTEST

IT IS a pleasure to be able to say, that although no discrimination was made against the single circuit in judging the Receiving Contest, three-circuit sets, or other than single-circuit types, won the contest "hands down." Although the single-circuit hook-up is satisfactory for isolated districts, we are, of course, opposed to its use in communities where the re-radiation is likely to disturb listeners-in. Of the four Prize Winners and four "Honorable Mentions," only two described a single-circuit outfit.

What conclusions are we to draw from the fact that comparatively few people with ready-made sets entered the Contest? It may be that many of them thought the Contest was open only to those with home-made apparatus, in spite of our announcement, "any kind of a receiver . . . any number of tubes." Another explanation, and one that seems logical, is that the purchaser of a ready-made set is generally interested primarily in the entertainment rather than the experimental phase of broadcasting; while the builder of a set is often "out after distance," and learns more about fine tuning than the owner of a bought set.

Be all this as it may, the "turn-out" in the contest was mighty good. We congratulate those contestants whose articles have been printed in these pages, and to all the others who sent in articles, photos, and hook-ups we wish to express our admiration of the fine work which they have done and our thanks for the reports which they submitted.





THIS AMATEUR HEARS LONDON REGULARLY

But this is scarcely strange because—he lives there. Frederic L. Hogg, Radio 2SH, of Highgate, London, numbers the following stations among his American acquaintances: WJZ, WGI, WGY, WOO, WOR, WEAF, and WDAF (Kansas City)! About 60 amateurs in the United States have also been heard, including 5ZA in New Mexico. Mr. Hogg says that his 10-Watt transmitter has been heard all over Europe

## Some Pictures the Contest Brought In

These Were Picked from Among Several Hundred, to Illustrate Various Phases of the Broadcasting Game. Home-Made Equipment Predominated



MR. J. H. L. FINKE AND SON BOB Of Evansville, Indiana. With this one-tube of theirs, they have heard Los Angeles in a pouring rain

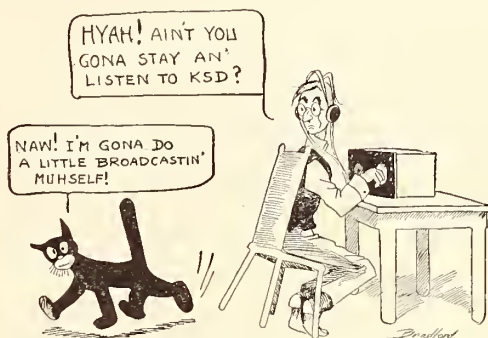

CARTOONIST BRADFORD SENT US THIS

When not drawing for the Philadelphia *North American*, he experiments with receiving sets which he builds himself

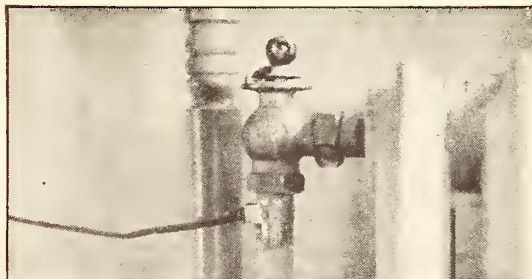

THE BETTER THE GROUND, THE BETTER THE SOUND

Bruce MacDonald, of Duluth, Minn., shows how heavy wire, a standard ground clamp, and a well-scraped pipe are "all there is to it"



THE CAPITAL CITY VIEWED FROM ONE OF THE CROSS-ARMS AT WRC

## A New Station at Washington, D. C.

A Description of WRC and its Meaning to the Capital

By PIERRE BOUCHERON

**O**N AUGUST 1st there was dedicated to the American public at Washington, D. C. another link of the great chain of broadcasting stations of the Radio Corporation of America. WRC has fittingly enough been named by its sponsors "The Voice of the Capital." To every corner of the United States, this powerful station may carry the words of great men in political and diplomatic life, the progress of world events as they transpire, and the music of our nation as well as of other nations rendered by visiting musicians. This station provides an instantaneous link between the country's political centre and the American home. A better understanding of government, of the issues involved in political campaigns, and of the questions which arise in our relations with foreign countries, cannot fail to result from its operation.

There is a wealth of material available in Washington from which to make the programs of WRC most enjoyable and educational. At once it is possible that the ceremonies accompanying the dedication of memorials to great Americans, the features of the many conventions held in this city, and the spiritual counsel of the clergy may be carried to the transmitter and sent forth so that the whole country may hear and appreciate them.

Momentous events, of interest to the nation, do not, of course, occur every day. The greater part of this station's operating hours will be devoted to the broadcasting of the musical and dramatic talent of Washington and other events of special interest to residents of this city. Washington is rich in both professional and amateur talent and every effort will be made by those in charge to arrange programs so that these local interpreters of music and



drama may be heard from time to time.

#### LOCATION IDEAL FOR RADIO

THE Riggs National Bank Building, in which both studio and equipment are accommodated, is one of the highest points in the city, with no tall steel structures near by to absorb and influence the waves radiated from the station. The office, studio, and equipment are all on the second floor of the building. Within the studio, which is one of the largest used in America for broadcasting work, all is harmonious, dignified, and restful. The panelled walls are done in old ivory and brown while the windows are draped with heavy hangings of maroon. A feature of the walls, which is not apparent while looking at them, is discovered when one touches the panels. The lightest pressure of the finger will bend them outward. These walls play an important rôle in broadcast transmission. They are made of wax-treated muslin laid over felt and absorb all sound waves not entering the microphone. This acoustically correct construction prevents even the minutest echo which might otherwise blur the clearness necessary to enjoyable entertainment.

#### "SEEING" THE BROADCASTED VOICE

ALL THE experience and recent improvements which are part of the Broadcast Central, the Radio Corporation's duplex station in New York, are embodied in Station WRC.

An important feature of this station, and one which further assures perfect transmission of programs, is the device known as the oscillograph, by which the operators have before them "a working picture of the voice." This delicate instrument may be switched into any one of the many circuits, and shows, by means of an undulating, ever-varying beam of

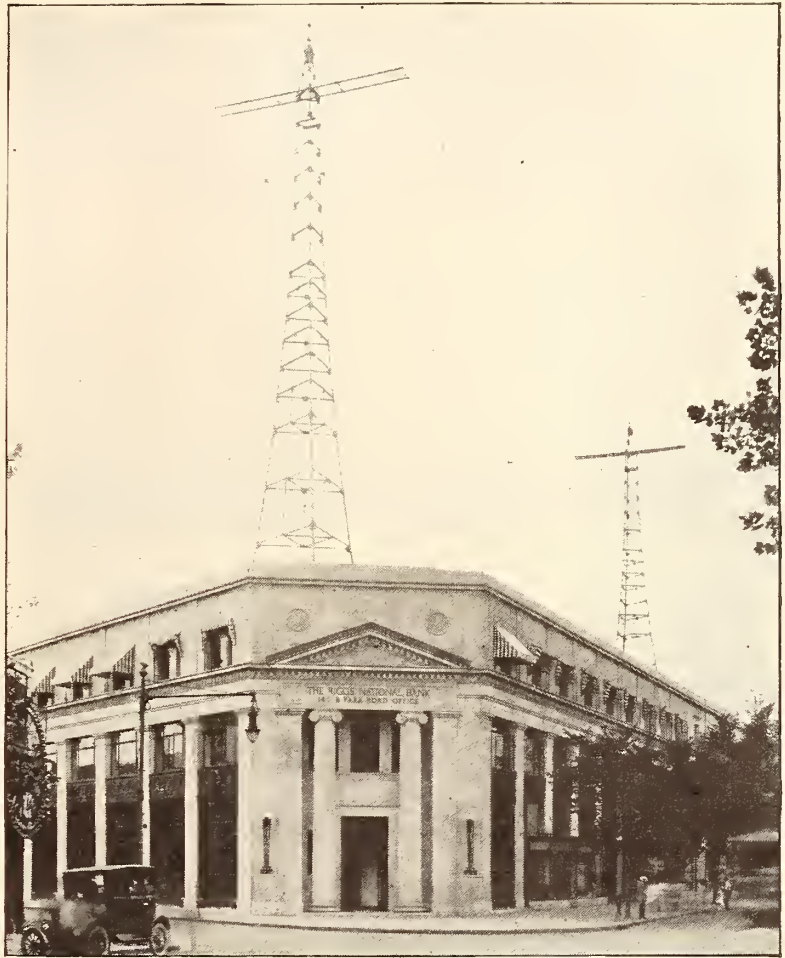

THE AERIAL WIRES ARE 150 FEET ABOVE THE STREET LEVEL

And there is nothing in the vicinity of the Riggs Bank Building which can obstruct the radiation of waves from this station

light, exactly how the artist's voice or music is affecting the radio current. By watching this little tell-tale beam, as reflected from revolving mirrors, one knows instantly whether the sound waves are too weak, too great in volume, or blurred.

Broadcasting is a living, vibrant force that has as its chief aim the improvement, both spiritual and intellectual, of mankind. When conducted on such a high plane as this, WRC cannot but thrill the distant listener with a constantly varying entertainment that falls little short of magic. It is the hope of those who conceived and built this great broadcasting plant that "The Voice of the Capital" will always entertain and instruct only with what is for the good and the advancement of the thousands who will nightly tune-in its message.

# Rheostats for the Tubes You Use

How to Select the Proper Rheostat. Operating Different Kinds of Tubes From the Same Battery. Using Tubes in Series and in Parallel.

By ZEH BOUCK

**T**HE advent of the dry-cell tube, while making radio a more simple and economical proposition, has by chance complicated matters when enthusiasts have attempted to operate such tubes from voltages other than those for which they have been designed—a possibility that is often made desirable by the possession of a six-volt storage battery. Similar difficulties are encountered when it is endeavored to light different makes of dry-cell tubes, with their individual filament requirements, from the same battery, and haphazard experiments by many fans have resulted in blown tubes. Such disasters, however, would have been obviated by an understanding of perhaps the most fundamental of electrical axioms, Ohm's law, and its application in solving the problems of the proper battery and rheostats.

Ohm's law is a statement of the three predominant characteristics of an electrical circuit, the voltage, current, and resistance, and the limitations imposed by any two of these qualities upon the remaining one, i. e., their inter-relation.

In the pioneer days of electricity, helped along by the fluid theory of electric currents that then prevailed, physicists were led by observations to the correct conclusion that electrical phenomena possessed two characteristics, voltage and current, the former being the pressure that sent the current through the wire, and the current itself being the density or heaviness of the electrical stream. It was found that this last quality, current, depended on two things, first upon the voltage or pressure and secondly, upon the resistance of the conductor or wire. As the pressure increased, it was quite natural that the current would become heavier; as would a lazy stream of water in a pipe when the force applied to the reservoir end was multiplied. It also followed, that as the resistance of the conductor was made greater, for instance by using a smaller wire, the current was decreased, as would be the flow of

water in the aforementioned pipe were a plumber to substitute a smaller diameter pipe or place some obstruction (*resistance*) within it. This law of electric currents is expressed in the equation,

$$I = \frac{E}{R}$$

I, E, and R mean, respectively, current in amperes, potential or pressure in volts, and resistance in ohms. Hence we might substitute for the abbreviations or symbols, and state the equation,

$$\text{current} = \frac{\text{potential}}{\text{resistance}}$$

or, still another way,

$$\text{amperes} = \frac{\text{volts}}{\text{ohms}}$$

By obvious algebraic transpositions, the two following equations are simply derived from the original statement:

$$R = \frac{E}{I} \text{ for finding resistance}$$

and

$E = I \times R$  for finding voltage or "voltage drop."

These equations are of inestimable value in all electrical work, and are particularly applicable, as will be shown, to the calculation of filament resistances and voltages.

## WHAT SIZE RHEOSTAT SHALL I USE?

**T**HE accompanying chart, Fig. 1, shows the three laws, and indicates the various computations in which they are commonly involved. The equation most readily applicable to the operation of the dry-cell tube is the second, and which declares that the resistance is equal to the voltage divided by the current.

We shall presume that the reader is interested in the construction of a portable set with detector and one step, using the UV-199 tubes. Referring to Fig. 2 (or to the circular accompanying the UV-199 when it is bought), it will



be found that this tube consumes .06 ampere at its normal filament potential of three volts. Three volts are the equivalent of two dry cells, but as the voltage of such a battery drops quickly, three cells should be used, in which case the deterioration can be compensated for by lowering the rheostat. We now encounter the problem, "Using these three dry cells, what size rheostat shall I get? Will not the six- or ten-ohm size be too low?" Or, more technically, it is desired to determine what resistance is required to drop the potential of the battery to three volts, or in terms of the second formula, what total resistance in series with the  $4\frac{1}{2}$  volt battery (three dry cells) will permit but .06 ampere to traverse the circuit.

To find this out, it is merely necessary to substitute the known quantities, volts ( $4\frac{1}{2}$ ) and amperes (.06) for the corresponding letters in the second equation, i.e.,  $R = \frac{E}{I}$  thus  $R = \frac{4.5}{.06}$ , or seventy-five ohms must be the resistance of the entire circuit. But, again referring to Fig. 2, it will be found that the resistance of the UV-199 filament is fifty ohms, which is necessarily included in the circuit, and forms the greater part of the seventy-five ohms resistance. Hence the extra resistance, or rheostat, need be only 25 ohms. (This is the *extra* resistance necessary to drop the  $4\frac{1}{2}$  volts to 3 volts, the working potential of the tube. That this is so will be proved by substituting in equation three:  $E = 25 \times .06 = 1.5$ —i.e., the voltage drop is 1.5, which subtracted from  $4\frac{1}{2}$  volts gives the required 3 volts!)

To find the resistance for any rheostat, substitute, in equation number two, the voltage of the battery and the current of the tube. From this answer, which is the total resistance of the circuit, subtract the resistance of the filament. (It is always desirable to add a few ohms to the result of this calculation in order to take full advantage of low filament consumption. Thus a 30-ohm rather than a 25-ohm rheostat is suggested for the UV-199.)

If the filament resistance is neither known

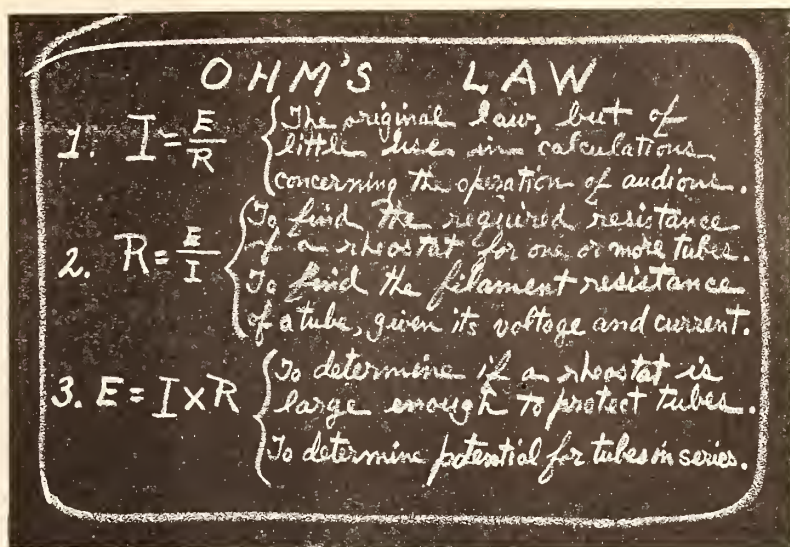

FIG. 1

Three ways of expressing the inter-relation of voltage, current, and resistance. They help you select the proper rheostats for your tubes

nor covered in the RADIO BROADCAST chart, it is easily calculated from the voltage and amperage furnished by the manufacturer of the tube, by means of this same equation two. Substituting these values in the case of the UV-199 just discussed, our equation is  $R = \frac{4.5}{.06} = 50$  ohms.

#### DIFFERENT TUBES WITH THE SAME BATTERY

IT IS quite possible that the owner of the portable set mentioned above will desire to substitute a WD-11 or WD-12 ( $1\frac{1}{2}$  volts,  $\frac{1}{4}$  ampere) for the UV-199 as detector. If the A battery is made up of three standard dry cells, a single one of these may be used to light the detector filament, obviating the necessity for any calculations. However, if a three-cell flashlight battery is employed, as is the probability, it will be easier to resort to resistance than to break through the insulating compound and tap the battery. Due to the different direct-current characteristics of this tube, it is quite obvious that its rheostat requirements will differ from those of the UV-199. (However, as the WD-11 does not require so high a resistance, as will be shown, it would not be positively necessary to change the rheostat.) The value of this rheostat is obtained by again substituting in the second formula, viz.,  $R = \frac{1.5}{.25} = 18$  ohms. Subtracting from this the resistance of the WD-11 filament, and adding a few ohms for safety and adjustment, the

desirable rheostat will have a resistance of 15 ohms.

#### IS MY RHEOSTAT LARGE ENOUGH?

ANOTHER problem which quite frequently confronts the experimenter running the eternal gamut of circuits and tubes, is the question as to whether a rheostat which adequately controlled a previous tube, possesses a resistance sufficiently high to safeguard the audion in his new experiment. This can, of course, be solved in a round-about fashion by the  $R = \frac{E}{I}$  formula, but by the third equation,  $E = I \times R$ , it admits of an easier solution, and it is only necessary to know the current consumption of the tube and the resistance of the rheostat.

We shall assume that the experimenter has been using in his amplifier Western Electric VT-2's, the 5-watt transmitting tubes. He has lighted these from an 8-volt storage battery through 6-ohm rheostats. Without changing his battery or other equipment, he now desires to substitute for these uneconomical bulbs the 201-A, a 6-volt,  $\frac{1}{4}$ -ampere tube. Will the 6-ohm rheostats be sufficient? . . . will they give a 2-volt drop (8 to 6)?

$$E = I \times R$$

$$E = .25 \times 6$$

$$E = 1.5 \text{ (the voltage drop)}$$

No! A larger rheostat will be necessary.

*To determine if a certain rheostat is sufficient to drop a high voltage to a required lower potential, substitute for I and R in formula three. The answer will be the voltage drop.*

#### TUBES IN PARALLEL

MANY enthusiasts have endeavored to operate dry-cell tubes and others in parallel from a single rheostat, the voltage dropping function of which was augmented by the increase in current passing through it. It will be observed from study of the last formula, that E, or the voltage drop, depends directly upon the amperage. If the current through a rheostat is raised, the voltage drop will be increased in proportion. For instance, if the experimenter is desirous of working a two-bulb set using UV-199's, from a 6-volt storage battery through individual rheostats, he will find by calculations in formula two, which we have described, that he will require rheostats of 50-ohms resistance each. However, if he connects the filaments of the two tubes in parallel,

lighting them through a single rheostat, only a 25-ohm rheostat will be required. (This fact will also be furnished by formula two, if it is remembered that the current is now doubled.) In terms of the third formula, this condition is as follows:

$E = 25 (R \text{ in ohms}) \times .12$  (current of two .06 ampere tubes). Carrying it out,  $E = 3$ .

Hence the voltage drop is three, which subtracted from six leaves 3, the correct voltage for the UV-199.

A single rheostat of 25 ohms is much easier to obtain than two 50-ohm instruments. However, the writer does not approve of nor recommend this *apparent* economy. On the contrary he advises strongly against it for the very reasons (Ohm's law number three) outlined above and which, at first sight, appear to favor this system. A little thought

will indicate the disaster which would, in such a circuit, accompany the failure of one of the tubes to light, either from socket or connection trouble, or burning out. Such a failure would lessen the current through the single rheostat and correspondingly curtail the voltage drop, and a disastrously high potential would be applied to the remaining tube.

To demonstrate mathematically (the reader cannot become over familiar with the algebra of Ohm's law): It was found that on two bulbs a 25-ohm rheostat was sufficient to drop the six volts to the required three volts. However, supposing that one tube ceases to function due to filament trouble, we shall find that the voltage drop,  $E = I \times R = .06 \times 25 = 1\frac{1}{2}$  volts. This would leave  $4\frac{1}{2}$  volts on the tube, sufficient to burn it out in a few seconds.

#### TUBES IN SERIES

THE alternative for using one rheostat with a plurality of tubes is connecting them in series, but this practice, while free from the hazards of the parallel system, multiplies the voltage, practically by the number of tubes. However, this system has been successfully used and is quite justified with amplifying tubes which number in radio-frequency circuits three and more (including audio), and where the higher voltage has been at hand or easily built up. The required battery for such a connection is simply determined by formula three. (It should be borne in mind that the answer given in this equation is the voltage drop in passing through the *mentioned* resistance. If





all the resistance in the circuit is substituted for  $R$ , the voltage drop will be the total applied potential, or *the required voltage for the operation of the circuit under the stated conditions of amperage and resistance*. Thus, in the case of the 199, where the filament has a resistance of 50 ohms, and for normal operation consumes a current of .06 ampere, the voltage will equal  $E = I \times R = .06 \times 50 = 3$  volts).

If it is desired to use four UV-199's (to continue with this popular bulb) in series and with a single 10-ohm rheostat, the following calculation is carried out:

First,  $R$  must equal the total resistance of the circuit, i.e., the resistance of all the filaments plus the resistance of the rheostat. (The resistance of the battery and wiring is negligible and merely adds a factor of safety.)

Second,  $I$  is the current of *one* tube, for the same current flows through all tubes and is not divided or split as is the case when passing through filaments in multiple.

Then  $R$  will be:  $10 + 50 + 50 + 50 + 50 = 210$ , and  $I$  will be: .06, and the equation,

$E = .06 \times 210 = 12.6$  or roughly eight dry cells (12 volts).

To find the required resistance for the operation of a series of tubes with a given rheostat, substitute the total resistance of the circuit and the amperage of one tube in formula three. If a fraction results, use the first whole number below it—the rheostat can always be turned up.

When the occasion arises for a calculation involving a single resistance controlling more than one tube, remember that filaments in

series multiply the filament resistance of one tube by the number of bulbs, and filaments in parallel divide it by the number of bulbs.

#### CONCLUSION

THE first Ohm's law or equation finds but little application to the subject discussed. The correct value for  $I$  is almost always known; it is determined by the designer of the tube, not by the chance values of  $E$  and  $R$ , and the two derived equations will solve in a more satisfactory way whatever filament questions the reader may refer to Ohm's law.

It will be observed that the writer, in discussing dry-cell tubes, has not confined himself to their operation from such a battery, but has even suggested their use from the storage type. The low-amperage tube has not merely made possible the elimination of the storage battery in certain justifiable cases, but has also added greatly to the utility of that battery. The storage battery possesses cer-

tain desirable qualities which are missing in dry cells, and in view of the slow discharge when used with dry-cell tubes, they deserve serious consideration as the filament source in all but portable sets.

In conclusion, the writer desires to emphasize that Ohm's law is not confined in its audion applications to any particular class of tubes, or voltages. It may be used in filament calculations involving 32-volt farm lighting plants, 110-volt D. C. system, and with any tubes whatever.

APPROXIMATE D.C. CHARACTERISTICS  
OF POPULAR TUBES

Type	E	I	R
200	6	1	6
201	6	1	6
201-A	6	.25	24
199	3	.06	50
215-A	1.5	.25	6
WD-11	1.5	.25	6
WD-12	1.5	.25	6

FIG. 2

If you know any two of the three predominant tube characteristics—voltage ( $E$ ), amperage ( $I$ ), and resistance in ohms ( $R$ )—you can find the third by the formulas given in Fig. 1



THE CREW OF THE "BOWDOIN," ROUNDED UP TO LOOK PLEASANT

Left to right: Donald H. Mix (radio operator), Tom McCue (mate), Richard Goddard (from the Carnegie Institute in Washington), Captain MacMillan, Jaynes (engineer), and Ralph Robinson (ship's doctor and official photographer)

## With MacMillan and Radio, North of Civilization

Adventures on the First Part of the Arctic Expedition, as Related by Mr. McDonald, Who Went with the *Bowdoin* as Far as Battle Harbor, Labrador. How the People in the North React to Radio, and What the Crew and Captain MacMillan Think of it

By E. F. McDONALD, JR.

**J**OHN Bunyan was a pious man and had lots to say about Sloughs of Despond and Giants Despair, but what a pity his well-known Pilgrim—ever on the watch for stepping-stones to progress—should have overlooked the rocks of Labrador and the well-trapped shores of Greenland. For *there* are regions for you with their very names all made to order for an allegory!

Think, for example, of the adventures that valiant fighter might have had while skirting "Anxiety Point" and "Escape Reef" and "Cape Hold with Hope," while dodging through "Frozen Strait" and "Cut-Throat Tickle,"

while sailing up "False River" and back, while circling "Ragged Island" or "Deadman's Cove" or "Devil's Bay"; and how great his triumph might have been when he finally sighted the "Isle of God and Mercy" and brought his errant craft around "Cape Comfort" through "Hopewell Narrows" and into "Refuge Cove!"

On such a voyage, on the twenty-third of June, sailed forth the staunch ship *Bowdoin*, captained by Donald B. MacMillan, the noted Arctic explorer, and carrying in its forecabin a radio transmitting and receiving set—the first of these sets to venture into the land of per-



petual ice and snow. Captain MacMillan was accompanied by a cook (a tremendously necessary person), several scientists, his friend, Sheldon Fairbanks, and myself. I left the party at Battle Harbor, Labrador.

#### THE DEPARTURE FROM WISCASSET, MAINE

IT WAS a brilliant scene at Wiscasset, Maine, when the *Bowdoin*—decks piled high with supplies and provisions, and masts strung with flags of the international code—set sail for the Arctic. All the people of the countryside turned out to bid the crew Godspeed. Whistles blew and cannon boomed

On board the ship for the first short stage of the journey (to Boothbay) were General A. W. Greely, oldest living Arctic explorer, and Langdon Gibson, who accompanied Commander Peary on his earlier Arctic expeditions. On shore, and in communication with the ship by radio, were Hiram Percy Maxim, the distinguished inventor, and Messrs. K. B. Warner and Fred Schnell, associated with Mr. Maxim in the American Radio Relay League, of which he is President. These last-named gentlemen had temporarily set up on the dock a Zenith receiving set, and for the first five miles or more they used it to receive and *transmit* messages. To accomplish this latter purpose, they set the secondary tuning on the wavelength that the *Bowdoin* was operating on, threw the tickler into the extreme oscillating position, and by touching the primary circuit with a moistened finger sent back their replies in international Morse code.

Donald H. Mix, radio operator aboard the *Bowdoin*, was furnished to the expedition by The American Radio Relay League, at the League's expense. He was chosen from among a great number of applicants for the coveted position. Long coded news stories are being received from the *Bowdoin* (station WNP) every week by various member-stations of the A. R. R. L., which expect to keep in communi-

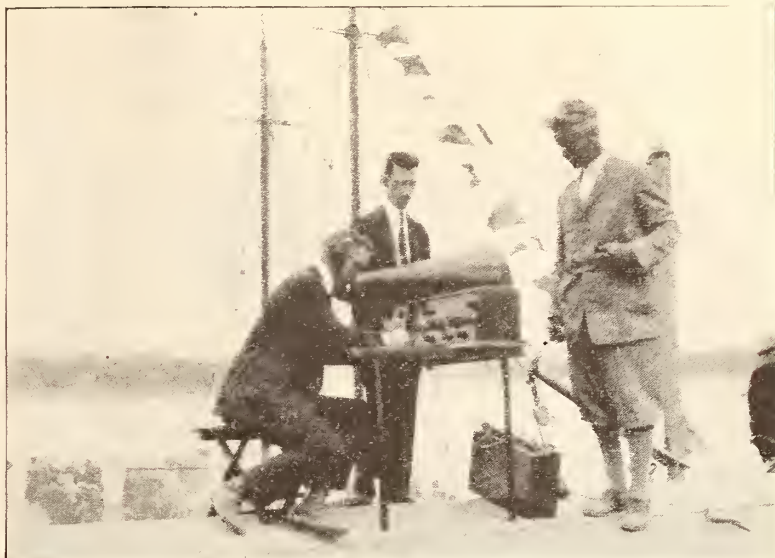

#### OFFICIALS OF THE A. R. R. L. AT WISCASSET, MAINE

On the right is Hiram Percy Maxim, President of the American Radio Relay League, the organization which is sending operator Mix with the MacMillan expedition; at the left is F. H. Schnell, Traffic Manager of the A. R. R. L.; and behind the receiving set is K. B. Warner, Secretary of the League and Editor of *Q S T*. The picture was taken at Wiscasset harbor, just before the *Bowdoin* sailed, and the set was used in testing with WNP during the first few miles of her long journey

cation throughout the winter, when the expedition will be at its farthest north, some 600 miles from the Pole.

From Monhegan Island we put to sea in earnest, and within the very first hour ran into an enormous school of blackfish. These are a species of whale, and some of them ranged a full forty feet in length. They were sunning themselves on the surface of the water, and so complacently did they regard us that we were able to approach within close hailing distance—so close, in fact, that Tom McCue got a rise out of one of them by heaving a can of pemmican against his tough black hide.

Clouds of fog enveloped us practically all the way from Monhegan to Sydney, Nova Scotia. Notwithstanding the impenetrable mist, however, we crossed the Bay of Fundy and rounded Cape Sable without mishap, and except for the glimpse of a mysterious ship during one of the night watches—which on our approach extinguished all her lights—we made our port without adventure. Not knowing whether the ship in question was a rum runner or a rum-runner *chaser*, we made no attempt to overhaul her.

From the moment the last visitor stepped off the gang plank at Boothbay, strict discipline was in force on board the *Bowdoin*. The day



THE CAPTAIN IN HIS QUARTERS

Behind him on the wall, may be seen several of the guns which he will use in the Far North

was divided into four watches: six hours on and six hours off, with one man at the wheel and two on lookout. We had breakfast at six, dinner at noon, supper at six, and a "mug-up" at midnight.

#### THE "BOWDOIN" AND WHAT'S ABOARD HER

"THERE is not much room to spare on the *Bowdoin*—as you can imagine when I tell you all that she carries. Not only is every available inch of space below decks used, but the main deck is crowded with barrels of fuel and lubricating oil, and miscellaneous provisions of an imperishable nature. The *Bowdoin* is only eighty-nine feet over all—the smallest ship that ever ventured an Arctic expedition—yet into her hold, amidships, have been packed not only provisions and supplies sufficient to sustain the party for several years, but also quantities of dolls, clothing, knickknacks, and phonographs, these latter to be presented to the Eskimos of the most northerly tribes. It was with difficulty that the hatch was battened down!

Back of the hold is the engine room, a solid

mass of machinery. Its four walls are enormous fuel tanks of kerosene, which give this ship the greatest cruising range of any small ship in the world. This enormous fuel supply is needed when one considers that for many days, with the engine running full speed, the ship, which normally makes nine knots an hour, makes less than nine knots a day against the heavy ice jams of the Arctic. In the forward end of the engine room are two  $\frac{3}{4}$  KW Delco generators and two complete sets of 32-volt storage batteries. At present, one generator and set of batteries are being used to light the ship. The other generator and batteries are for the radio, which consumes a great deal of power in hurling its wireless messages back to civilization.

Back of the engine room, in the after end of the ship, are the Captain's quarters, very small and compact. One of the two berths shown in the picture is Captain MacMillan's; the other that of the ship's doctor, official photographer and general handy-man, Ralph Robinson. In the middle of the cabin stands the Captain's chart table with its chart rack



and navigating instruments. Lining the upper wall is a very complete library of scientific books. The forward wall presents the scene of an arsenal, with at least twenty rifles, ranging in calibre from the small .22 equipped with Maxim silencer, to the large .401-calibre bear and walrus rifles.

Small side-arms have no place on this expedition. As a matter of fact, there is only one revolver on the ship, and that is owned by Richard Goddard, representative of the Carnegie Institute of Washington. He explained to me that he carries it only for protection while away from the ship making observations in terrestrial magnetism. On the back wall of the Captain's quarters are fastened two delicate chronometers, which are being checked by the radio time signals from Arlington each day. For this purpose an extension wire has been run from the Zenith receiving set in the forward part of the ship to a position directly alongside the chronometers, which position is

incidentally directly alongside the head of the Captain's berth. While the extension was primarily for setting the chronometers, the Captain sometimes lies in his berth with the headphones over his ears and listens to the concerts that are being broadcast from the stations along the Atlantic Coast and from WJAZ, Chicago, and WOC, Davenport, Iowa.

UP FORWARD, WHERE THE RADIO SHACK IS

THE forward end of the ship is taken up with the forecabin, comprising the radio room, living and sleeping quarters of the crew, and the galley. The radio room is in the peak of the forecabin, berths for six men are along the sides, the mess table is in the centre, and the galley in the after end of the forecabin.

"I tell you, things were lively in the forecabin when the radio started! In such close quarters, it made as much noise as a steam locomotive tearing up and down the passageway! The first night it was in operation the



THE DECK, FROM THE CROW'S NEST

The *Bowdoin* is driving north under sail and motor-power, heavily loaded with drums of fuel and oil, and supplies and provisions enough to last several years





E. F. McDONALD, JR., WHO TELLS OF EXPERIENCES ABOARD THE "BOWDOIN"

He returned from Labrador recently, having left the expedition there after accompanying it from Wiscasset, Maine. Mr. McDonald is connected with station WJAZ, in Chicago, which is keeping in constant communication with the *Bowdoin* and is sending out special programs for those on board

cook arose in great consternation, believing bedlam had broken loose. He rubbed his eyes furiously, finally discovered the source of the disturbance, and exclaimed: 'I have been ship-mates with a lot of powerful snorers, but never with such a noisy beast as that there animal.' Strangely enough, however, a few nights' companionship with the set made its noise as undisturbing as the town-clock to a good New Englander, and every man of us was able to sleep as soundly as a village constable.

#### THE EXPEDITION'S RECEPTION IN NOVA SCOTIA

SYDNEY, Nova Scotia, was our first important stopping place. Anchor was dropped at North Sydney the first night because of the intense fog. Next day found the *Bowdoin* gracefully gliding into Sydney Harbor amid the roar of salutes from the French gunboat, *Regulus*, anchored in the harbor. At first the cannonading worried us, because we had heard the night before of a strike waging in the coal mines and steel mills, of Canadian troops moving in, and of threatening trouble. But our doubts soon gave way to delight over the warm

reception and extreme courtesy of which the cannonading was the first evidence. The guns were not turned toward us. This was July first. I shall never forget what a thrill it gave to see the American, Canadian and French flags flying from the Royal Sydney Yacht Club. and from public buildings and private residences. Such was the interest shown in the MacMillan exploration trip on the national holiday of the Canadians.

Sydney is the outpost of civilization—the last place on the trip showing signs of modern-day progress. Here Captain MacMillan had his last ice cream. Considering the climate of the Polar regions, he will probably be able to bear the separation from ice cream fairly well.

Leaving Sydney we headed northeast through a dense fog and caught only a glimpse of Newfoundland as we passed by. This was Port-aux-Basques. Fog whistles blew at other points along the Newfoundland shore, but only at the one point did the fog lift its veil long enough to permit a view. Likewise most of the coast of Labrador remained a mystery to us. Often we thought land directly ahead, but



as we approached the dim outline of the supposed land there was gradually revealed the form of an iceberg. So many icebergs strewed the way that traveling was exceedingly dangerous.

#### PUFFINS AND ICEBERGS

OUR first stop in Labrador was in back of Greeneley Island, at night and under cover of fog. Next day when the sun rose, about 3:00 A. M., we found ourselves within 100 yards of shore. Had it not been for the wonderful navigating of Captain MacMillan, we should many times have been piled on the rocks along that formidable Labrador shore. Captain MacMillan made this stop to visit and examine Parquet Island, which is a rookery of the puffin. These puffins are known as the "Parrots of the Arctic," are wonderfully colored, have the characteristic parrot bill, but feed on fish. Millions of them swarm the island which is scarcely a mile square.

To bring the puffins out of their hiding places, it was only necessary for us to lie on the ground for about five minutes. Then the heads began to bob up all around. We took some specimens of these birds and also some of the eggs. These are as large as hens' eggs and are one source of food to the natives.

While the Captain, Fairbanks and I were on this island, three of the crew decided to visit their first iceberg. Directly after they left it, the iceberg decided to turn over. It was interesting to hear the Captain tell these men, upon their return, of the lurking dangers of the iceberg. Parquet Island is located in the Canadian Labrador Section. On the mainland, half a mile away, a tent was pitched in open view. This, we were later informed, belonged to the Government Game Warden, but the Canadian Government, although equipping him most excellently in every other way, failed to furnish him with a boat!

#### FOG, AND A FORBIDDING COAST

AS WE passed north along the coast of Labrador, it was seldom that the fog

permitted us to see land. The curtain very accommodatingly rose as we passed Point Amour, where we were given an opportunity to take pictures of the wreck of the battleship *Raleigh*, once the pride of the British Navy, but now piled high and dry on the rocks. Even her guns are still mounted. While we were passing through some of the thickest of the thick fog, with the rocky shore of Labrador only a short distance from us on our port side but completely shut off from view, the cook, who was on his first trip to the Arctic, came on deck; and the Captain, pointing towards where he knew the land was, said: "Well, Cooky, how do you like your view of Labrador?" The cook gazed intently and seeing nothing but fog, asked: "Is it always like this?" "No, not always," replied the Captain; but at that point Robinson confided the surprising information that only once in his fifteen years of Arctic exploration, had the Captain seen the whole coast of Labrador without fog. The coast, when visible, is an enormous pile of unfriendly rocks.

In Captain Cartwright's "Journal of Labrador," written 143 years ago, he says: "In sailing along this coast, the astonished mariner is insensibly drawn into a conclusion that this country was the last which God made and that he had no other view than to throw together there the refuse of his materials of no use to mankind. Yet the mariner no sooner pene-



ONE OF THE BIG ONES PASSED BY THE "BOWDOIN"  
Only about one-tenth of it shows above the water

trates a few miles into a bay than the great change, both of the climate and prospects, alters his opinion. The air then becomes soft and warm; bare rocks no longer appear; the land is thickly clothed with timber, which reaches down almost to high-water mark, and is generally edged with grass. Few stout trees are to be met with, until you have advanced a considerable distance and have shut the sea out." Perhaps; but we found this country dismally cold, barren, rocky, and uninviting.

The natives of the villages who make their living by fishing for cod and salmon have in their backyards piles of wood, sometimes 15 to 20 feet high, the largest piece not exceeding two inches in diameter. It is all of scrub growth. The missionaries told us that in the winter the poor inhabitants must travel miles and miles with their dog sleds, quite content to find even this scrub growth. It is true that the air becomes warmer as you travel inland, but it is also true that the moment it does become warmer you see flies as you have never seen them before. The air is literally thick with them.

There is snow everywhere on the mountain tops and enormous balls of ice on the shore. At one point 89 icebergs were visible from our crow's nest. One of these icebergs was in the form of an arch, so high that had we been sure the water was clear below we could have sailed our ship through. The very names of the bays, capes, and islands indicate the hardship that has been experienced in this God-forsaken country. Some have already been named. Here are others strongly descriptive:

Mistaken Cove	Cold Foot River
Lower Savage Islands	Battle Harbor
God Haven	Windy Tickle
Misery Bay	Fly Away Cape
Cape Farewell	Punch Bowl
Death River	Lost Hope
	Dead Man Lake

#### WHEN THE NATIVES LISTENED-IN

AS WE entered each of these Labrador ports a group of small dories would invariably put out from the shore, and a race would start among the fishermen to see which could reach us first. After the usual preliminaries of getting acquainted they would ask: "Is there a doctor on board?" Next, they asked for clothing of any description. We found many

of the hardy fishermen, bronzed, weather-worn, and thin, clothed in a pair of old cast-off-looking oilskin trousers, a threadbare sweater, a battered pair of boots, and nothing more. The fishing has been bad for the past two years. There is an abundance of fish this year, but the inhabitants are faring poorly because of the enormous quantities of ice which tears their nets to pieces and often carries them away completely. These people are mostly of French, Irish and Scotch descent. In one port a native offered us lobsters for sale. He had a dozen and apologetically explained that the price of lobster was very high this year. Having left the States but recently the argument of short supply and over-demand was not new to us, and we were quite prepared for a South Water Street price. So he asked the exorbitant figure of ten cents apiece for the lobsters.

Wherever we went, people were all agog with excitement over the radio carried on board. They were glad of visitors, glad of the chance to exchange courtesies, but glad especially to view the equipment of the *Bowdoin*. Their wonderment struck its height when they listened to voices and music from far-away places in the United States, the land which they know but little, and none had seen. It was gratifying to notice their frank and open reaction, so childlike, so sincere. Electric lights, telephones, and such developments which have long been "necessities" with us, are of course only names to these people.

On July 4th, with the icebergs completely surrounding us, we received the returns of the Dempsey fight. The pool which we started on board for the man who guessed the number of rounds that the fight would last was temporarily won by Jaynes, the engineer, and paid to him when the fight had gone to twelve rounds, that being the number he selected. But the money was promptly taken away from him when the fight went on to fifteen rounds.

In Battle Harbor, Labrador, where I left the expedition, we were met at the dock by the doctors and nurses of one of those wonderful institutions, the Grenfell Mission, where self-sacrificing men and women give their time and energy without remuneration, caring for the sick and injured that are brought to them from miles around. Contact with them was especially delightful. They made an indelible impression for their devotion to a noble cause,





their unselfishness, their genuineness and ease of manner, and their lively interest in us as visitors. They visibly enjoyed everything quite as heartily as the natives, but had the added advantage of education and refinement. They too were absorbed with the Zenith radio outfit and not only enjoyed listening to the concerts but took every opportunity to dance to the strains from far-away stations, even the Edgewater Beach Hotel station in Chicago.

What I enjoyed as much as, if not more than anything on the whole trip was the opportunity to get to know that wonderful optimist, Captain Donald B. MacMillan. To me, his optimism is unparalleled. If it rains, it rains. If it is cold, it is cold. If there is a mishap of any kind, it is accepted by Captain MacMillan in contented spirit, and in full confidence that no matter what occurs, it is for the best. He never looks backward, always forward. He sees a bright side to every situation, every occurrence.

Captain MacMillan and his crew were well and happy when I took my leave. One comforting thought over the separation was in realizing that communication with them would not be cut off as it had been until their return to civilization on previous trips, but would be main-



MACMILLAN—SKIPPER OF THE "BOWDOIN"

tained by means of the first radio outfit to be introduced to the land of the Eskimo.

Every Thursday at midnight, WJAZ, the Zenith Edgewater Beach Hotel station broadcasts a summary of the week's news to these men in the frozen North, together with messages from their relatives and friends. Hundreds of miles from civilization, utterly surrounded by ice, they will yet have the news of the world as quickly as we at home, and may relax from their strenuous vigils to listen to the identical strains, perchance, to which their friends in the States may at that very moment be dancing on the polished hotel floors!

## What Balloon Racers Did With Receiving Sets

How Contestants in the National Event Held on July 4th Obtained Storm Warnings and Entertainment. Their Recommendations for Future Races

**L**IEUTENANT R. S. OLMSTEAD, winner of the National Balloon Race which started from Indianapolis on July 4th, attributes his success in a large measure to radio. Lieutenant Olmstead said that during the early part of the flight the air was remarkably free from static,

but that on July 5th, when west of Buffalo and at an altitude of 8,000 feet, he experienced considerable interference during a period when an electrical storm was brewing. His balloon was equipped with a standard airplane antenna—that is, about 300 feet of copper wire. For a ground, he used 25 feet of three-foot

copper screening, such as is used for fly screens. His official report, in part, follows:

"1—In compliance with request, there follows a brief account of our experience with the radio set 'Radiola 11' carried on the U. S. Army Balloon S-6 and furnished by the General Electric Company.

"2—The radio installation complete with antenna and counterpoise weighed about 30 pounds. In weight, therefore, it represented roughly one bag of sand ballast. Both Lieut. Shoptaw, my aide, and myself agreed many times, upon receiving a particularly enlightening bit of information, that it was worth several times its weight in sand.

"3—Immediately upon taking off, we dropped our antenna, connected our ground, and made plans to receive. The results were uniformly good from the start. One musical program after another came in with great clearness, and incidentally the returns on the Dempsey-Gibbons fight, round by round. There seemed to be music in the air at all times and to any one who has experienced the monotony, when everything is going well, of the hours of darkness in a balloon-race flight, the value of such restful relief therefrom is very evident. It materially added to our efficiency through assuring rested nerves. At times, the

audibility of the set was sufficient to allow us to leave the headset hanging to the side of the basket.

"Now for the more primely important features of having such an instrument along. From Detroit, Chicago and Schenectady, particularly Schenectady, we received quite definitely the weather reports consisting of general flying conditions, wind directions and velocities, cloud conditions, and—of great importance—the pressures recorded at various important cities. This information was quite conclusive in influencing our tactics to obtain a suitable direction of flight in order to obtain maximum endurance and distance.

"A feature which should be added to the radio set, if possible—one which we keenly felt the need of while out of sight of any landmarks or other means of locating our position or rate and direction of progress over Lake Erie—is a direction-finding apparatus.

"A point of vital importance in a race, and one which had considerable bearing on our decision to land at the time we did, was the advice received by radio of the location of our various competitors from time to time. At the time of landing, we knew that all but three of our competitors had been accounted for, and we were quite certain through deductions

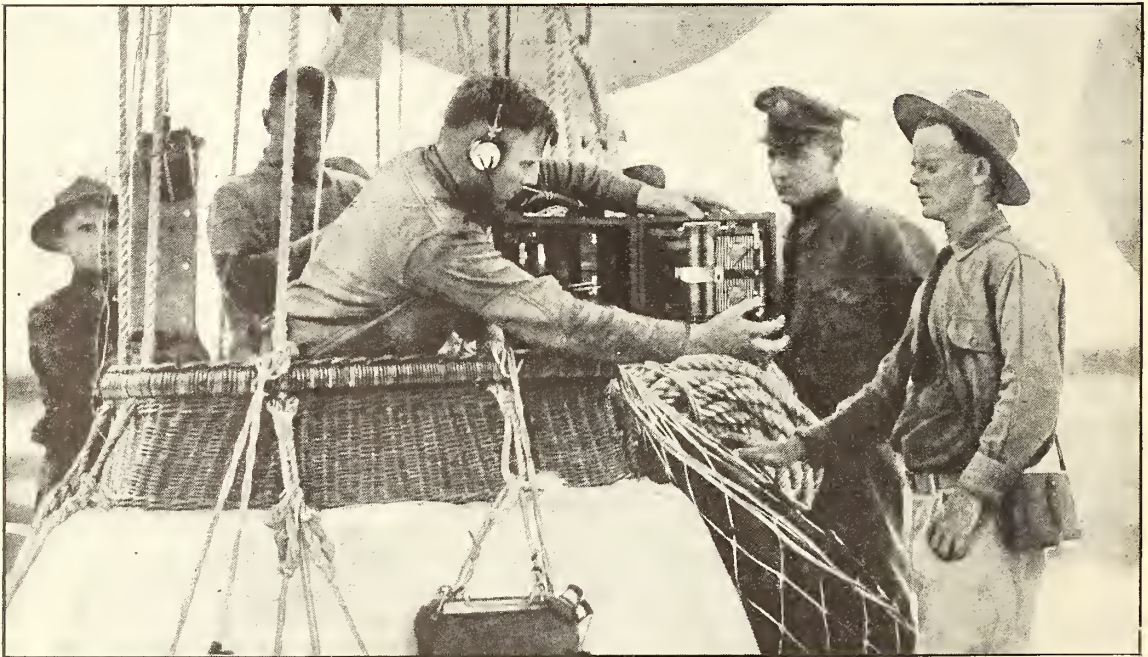

LIEUTENANT OLMSTEAD JUST BEFORE THE START

He is shown with the two-tube dry-cell outfit which helped him win the race. Radio rendered material assistance to the balloonists through the weather reports sent out from five broadcasting stations



from information previously received of the progress of others that we were at least in one of the three winning positions and eligible for the team to go to Belgium for the International race. Had we not had this information, we might have tried to cross Lake Ontario without sufficient ballast, failure in which would have disqualified us.

"4—My recommendations are that most emphatically a radio set should be installed in every racing balloon; that directional apparatus should be added, and that two head-sets should always be provided."

#### CAPT. MILLER PRAISES RADIO

BESIDES Olmstead's balloon, the three other army balloons which entered in this race were equipped with receiving apparatus. Captain Lester T. Miller wrote the General Electric Company as follows:

"Lieut. Brown and myself during our flight found your set worked very satisfactorily in every way. As you know, the counterpoise we used was a seven-strand copper wire, woven fifteen times about our basket. For our aerial, we used 300 feet of the same kind of wire. During the night of July 4 and on July 5, we flew at an altitude of about 4,000 feet. All our weather reports were received very clearly; in fact, the clearness of tones surprised both of us, as they were clearer than our regular station sets on the ground.

"On July 5, after 8:30 A.M., we flew at a higher altitude, and at heights of 5,000 feet and above we found the static was so bad that we were not able to receive satisfactory signals."

Ralph Upson, another of the contestants in the race, also equipped by the General Electric Company with the same kind of a receiving outfit, says there was a total absence of static at 3,000 feet. For six weeks preceding the race, Upson had used the set in his home and had become thoroughly familiar with its operation under various conditions. One of the uses he planned for his radio outfit in the race was to detect thunder-storms before the lightning was visible, so he took pains to learn how the static came in under various weather conditions.

Five of the principal broadcasting stations had arranged to send out special weather reports regarding the upper air currents during the first night of the race and the following morning. In regard to this, Upson says:

"Andrus, my aide, acted as chief radio oper-

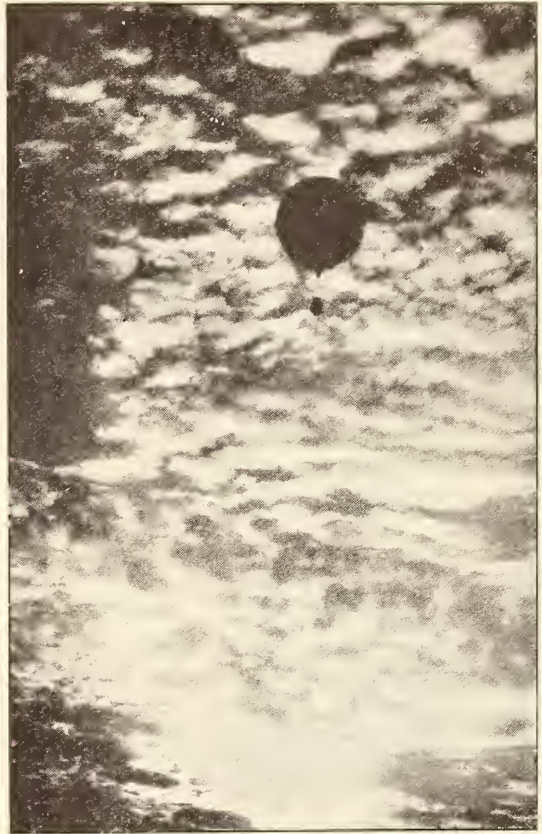

A SAIL THROUGH THE SILVER LINING

This photo was taken by Mr. Ralph Upson from his own balloon, during the national race which started at Indianapolis on July 4th

ator. He began listening-in at 8:30 o'clock the night of the race. At first he could hear nothing but code signals, concerts from various stations, and a radio drama that was being sent out from a Chicago station. For an hour, this was about all we could hear. Then at 9:45 o'clock, Central time, Andrus picked up the latter part of the weather report being broadcasted from WGY in Schenectady. We heard just enough of it to make us wish we had heard the entire report. However, our disappointment was short, for a few moments later the whole report was repeated, every word being received clearly and distinctly. It was *just* the news we wanted.

"As a result of the information, we decided to go a little higher but not to try any high altitudes unless forced to it by thunder-storms. The report gave us full confidence of reaching New York State, and possibly New England. Everything seemed so favorable that I turned in to sleep."

# What You Should Know About Condensers

Condenser Losses. Variable Air Condenser for Radio Use. Disadvantage of the Conventional Form of Condensers. What Materials Are Best for Condensers

By ALLEN D. CARDWELL

## PART II

Last month Mr. Cardwell explained the theory underlying the construction of condensers and their function in electrical circuits. In this second and last part of his article, various practical considerations are taken up, with the purpose of showing the radio enthusiast how to select the best apparatus. As stated last month, "If receiving set owners would buy their variable condensers after a survey of the mechanical and electrical characteristics of the types on sale, rather than from a comparison merely of general appearance, hearsay, and price, there would be less trouble with thousands of receiving sets and less apparatus of inferior quality on the market . . . . A familiarity with good and bad condenser construction is worth any enthusiast's while to obtain."—THE EDITOR.

**L**OSSES in the dielectric used in a condenser are one source of signal "damping" as pointed out at the conclusion of the last article. These losses are high in solid dielectrics and low with air dielectrics.

The first thing we observe when a condenser is used in a high-frequency circuit is that the current may be dissipated in the dielectric. Thus, if we force 1 ampere of current into a condenser and when it discharges we only get back .9 amperes, there has been a dielectric loss of .1 ampere due to the creepage across the space between the plates. Some of the current must have "leaked" through the dielectric or have been absorbed in the dielectric itself.

These losses are normally too small to measure when the dielectric is only dry air, but under certain conditions the leakage can increase to an appreciable extent. In a solid dielectric, this loss is always appreciable and accounts in one way for the preference of radio engineers in using air as a dielectric wherever possible.

The next effect we observe is that some of the current may be dissipated in the conducting plates. If the different plates are so assembled that there are uneven pressures at supporting points or along the frame, we have loss from "contact resistance" aggregating a fairly high value.

Again we have condensive effects set up in any insulation used to support the condenser

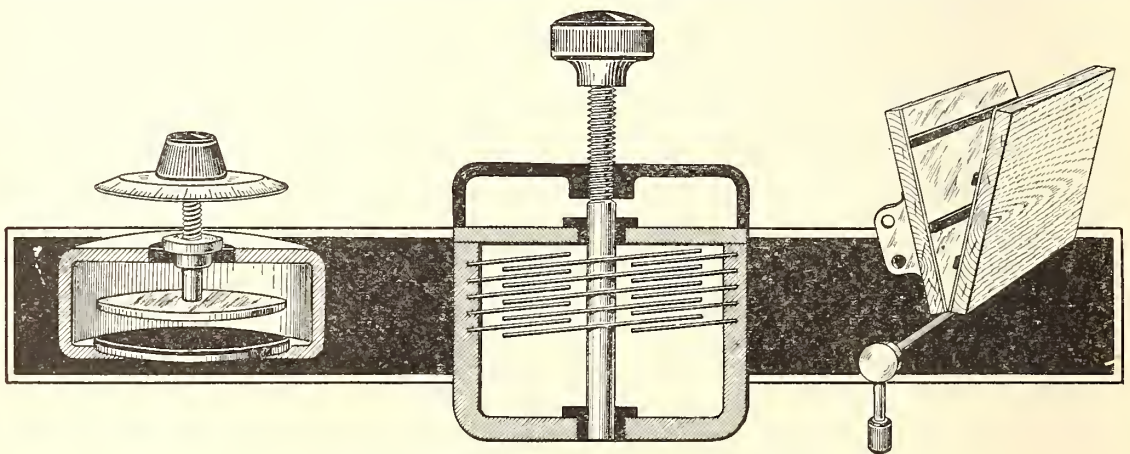

THREE TYPES OF VARIABLE AIR CONDENSERS  
"Up and Down" Motion—"Cork-Screw" Type—Book Leaf Type



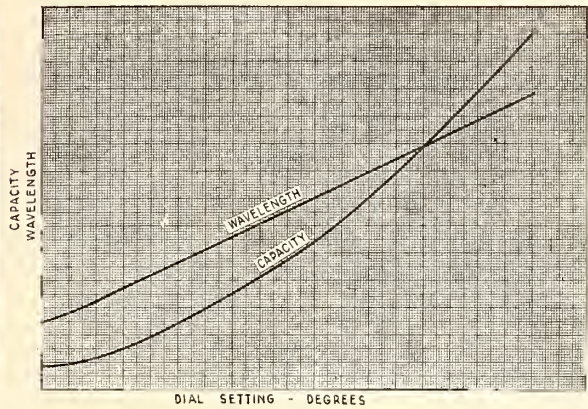
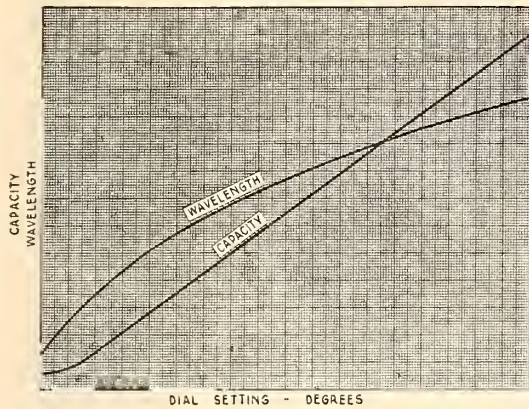

CURVES FOR "STRAIGHT LINE" AND "DECREMETER" CAPACITY RANGES

The curve at the left shows how a condenser having a constant capacity increase varies for wavelength when used with a given coil. The curve at the right shows how an eccentric-shaped plate will correct this and give a constant increase in wavelength when used with the proper inductance

walls. Although these insulation pieces may not be intended as part of the dielectric, they are sometimes so placed as to be in the electrostatic field and some of the current works into this supporting insulation and causes losses from leakage, and from a source we call "dielectric hysteresis." Hysteresis losses are the result of impurities or cellular structure, as in wood, where the arteries of the grain may have innumerable moist passages to shunt the current from point to point. Thus the insulation may pass minute currents in and out internally and may refuse to yield up the current with a uniform speed—in any event less quickly than the dielectric proper and thus cause resistance effects merely by failing to discharge synchronously with the main dielectric. This reveals the important factor of time or rate of discharge in dielectrics. We can charge a dielectric material such as paper to a given potential and upon short circuiting get back most of the charged current, but if we short circuit it a second time (after a minute has elapsed) we may get back additional current which we did not think was still in the dielectric or paper.

An ideal dielectric is perfectly elastic electrically. It springs back to its normal condition of equalized potential of zero grade the instant it is short circuited.

Another consideration is the possibility of losing a certain amount of current by "stray field" or parasitic effects. If a body of metal is in or near the dielectric field, it will act as a supplementary condenser in interaction with one or the other sides of the condenser alter-

nately. Thus, with many receiving sets, the panel is shielded. This means that the shield acts as part of the condenser and in doing so, a secondary condenser exists and losses may be caused since the shield may have conduction resistances as well as insulation hysteresis effects.

The losses in a condenser may thus be summarized as follows:

- 1 Dielectric leakage
- 2 Dielectric hysteresis
- 3 Insulation leakage
- 4 Direct-current resistance in plates
- 5 Stray field capacity
- 6 Insulation hysteresis

*These losses can be reduced to such a point that the most sensitive instruments devised to measure resistances cannot accurately indicate or check any losses whatever.* This is not an exaggeration. It does not mean, however, that there are no losses, but that the losses are so small that it is impossible, with unusually delicate equipment, to determine them.

Let us therefore consider various designs of variable air condensers (with which we are primarily concerned). Where do the various types of such condensers excel and where do they fail to secure proper efficiency?

A variable air condenser as generally designed consists of a series of fixed plates of semi-circular shape, so spaced that a second set of similar plates can intermesh between the fixed plates. The fixed plates are called the stator plates and the movable plates are called the rotor plates.

We can vary the capacity by the amount of

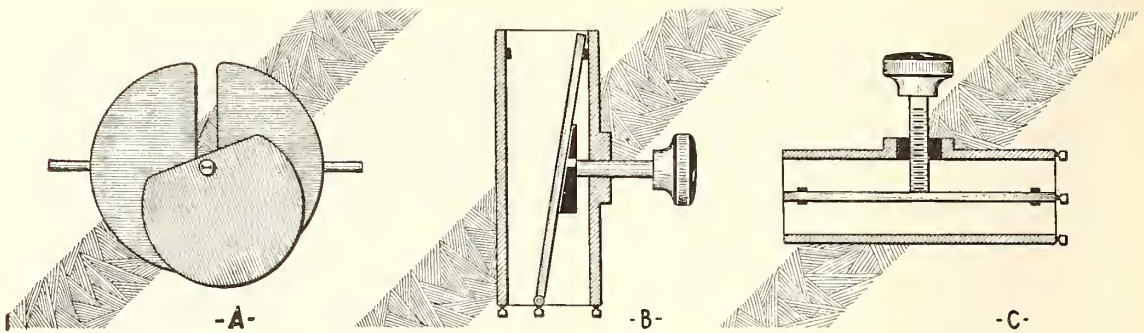

Three new types of coupling condensers: A—the Jones condenser used in neutralizing circuits; B—an old French design, revived recently by Allen D. Cardwell for use with the capacity-coupled, double-circuit tuner; C—a navy type coupling condenser

intermeshing of the rotor and stator plates. The variation of the intermeshing can be made to cause an equal increase of capacity for each degree of rotation. This may be an advantage in that it makes the controlling dial cause capacity changes directly proportional to the number of degrees through which the condenser dial is turned, but it does not increase wavelength uniformly. To do this, an eccentric shape is made for the rotor plates, and when used with a given coil the condenser changes cause a straight-line wavelength variation. In this case it is called "linear" because its wavelength variation, shown in a graph, would be a straight line. At the same time the advantages of the "straight line" or linear shape are relatively small for ordinary tuning, compared with the added cost of manufacture and the disadvantages of the extra cubic volume required for given capacity.

A variable condenser can also be constructed so that the plates (generally limited to two in

practice) are moved closer or farther apart in a direction at right angles to the planes of their surfaces. Owing to the necessity of using a thin sheet of insulation between the plates to prevent short-circuiting, this type of condenser will not vary proportionately with the mechanical control variation. As the space or dielectric thickness decreases, the capacity increases more rapidly than the turns on the threads or knob-mechanism, because the amount of solid dielectric has become greater in proportion to the amount of air dielectric and most solid dielectrics have greater specific inductive capacity.

A third system for a variable condenser is to hinge two plates and vary the spacing by closing or opening the free ends, as a book

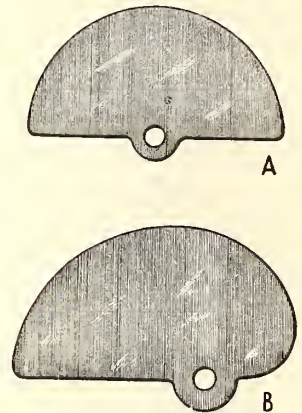

ROTOR PLATE SHAPES

A is the normal or standard shape, giving a "straight line" capacity increase

B is an eccentric shape to give a constant wavelength increase when used with the proper coil

cover is opened or closed. In this type of condenser the capacity also increases rapidly as the distance between plates is reduced beyond a certain point and, as in the reciprocating system, a good capacity rating is secured only by closing up the dielectric gap so closely that short circuiting would occur if solid insulation of some type is not placed in the electrostatic field. This means an air and solid dielectric are used so that what convenience is gained in higher capacity of the

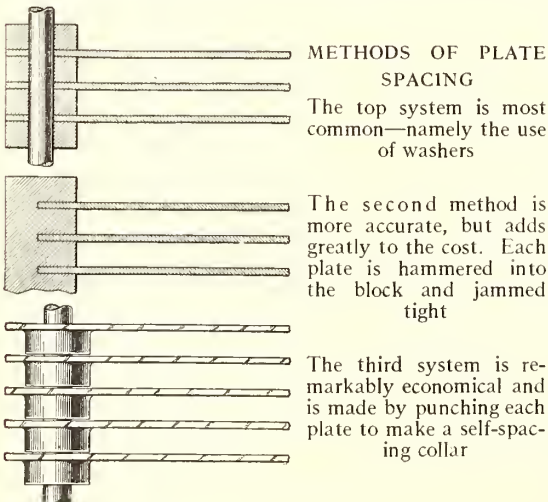

METHODS OF PLATE SPACING

The top system is most common—namely the use of washers

The second method is more accurate, but adds greatly to the cost. Each plate is hammered into the block and jammed tight

The third system is remarkably economical and is made by punching each plate to make a self-spacing collar



plates when close together is thus lost by the resistance of the solid dielectric.

A fourth style of condenser has occasionally been proposed—namely, a “screw type” in which the rotor plates are cast as a continuous “cork screw.” Being a complete circle, the plates can double the capacity per plate area and increase the capacity at a very slow, constant rate.

Other rudimentary methods of varying capacity have been used—for example, a set of moving plates sliding along grooves into the fixed plates, or some with one tube telescoping over another. These designs have in general one or another of the following defects:

- 1 The increase in capacity is not linear
- 2 The cost of production is too high
- 3 The maximum capacity is either small or secured by high dielectric losses
- 4 The mechanical construction is not strong or is clumsy or bulky
- 5 Variable settings for given capacity

For tuning receiving circuits, a condenser should occupy small space, increase wavelength evenly with all changes of the dial, and have a large range of capacity from minimum to maximum.

The intermeshing-rotor design has become the standard in radio practice.

In the design of the standard variable air condenser a number of mechanical methods

are followed. In spacing the plates of either rotor or stator, washers are often used. These are placed on supporting rods so that on assembly a plate is held in position by the flat faces of the alternating spacers.

This system has disadvantages. In the first place the spacers require tedious hand assembly. In a 43-plate condenser, for example, there would be three spacers per plate, or in all 129 spacers to be set as well as 22 plates of the stator and 21 plates of the rotor. Where the spacers are also used on the rotor, it would entail more than 256 distinct hand motions aside from locking the end plates and tightening all adjustments.

In itself, the labor is not as serious as the electrical inefficiency. A certain amount of oil, moisture, or surface unevenness is cumulative where each spacer touches a plate. The resistance is thus multiplied by the 256 or so contacts and aside from any other losses, the resistance may be considerable. Even soldering the joints does not satisfactorily overcome the mechanical weakness of the design. Fusing the metal would be the only way of assuring permanent low contact resistance.

A better method of design is to cut a solid die by which the plates are cast as a solid part of the frame support—usually a flat semi-circular wall, thus supporting the plates by half of their circumference and having minimum resistance in the support. This type of condenser with

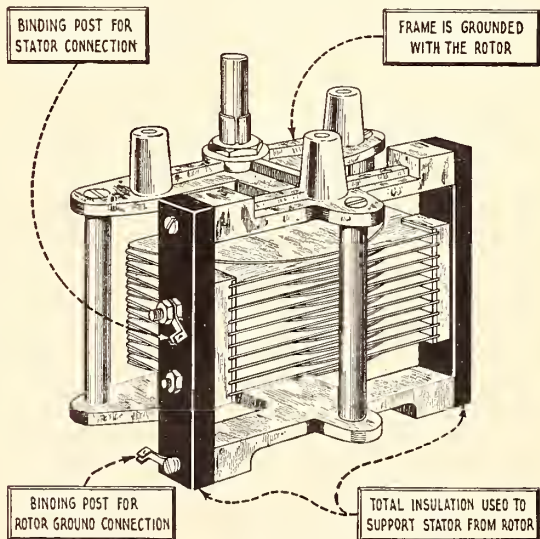
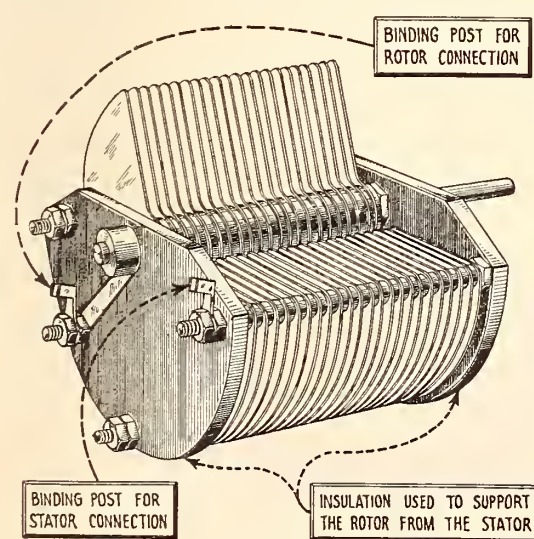

TWO WAYS OF INSULATING THE STATOR FROM THE ROTOR

At the left, the rotor is supported by end plates of insulation. Either rotor or stator can be grounded. The condenser on the right shows a design in which the rotor is part of the frame connection, permitting the use of less insulation. Only the rotor can be grounded

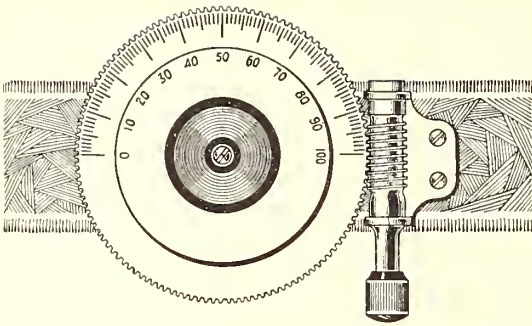

MECHANICAL VERNIER

This type gives a ratio of 256 to 1 which is truly a micrometer control

good bearings can be very closely spaced, that is, the dielectric thickness or clearance between stator and rotor can be extremely small. The cost however is high, due to the shape and accuracy required.

The surfaces of the plates cannot be smoothed down and are difficult to keep free from dust which will quickly cause minute short circuiting paths. Even when invisible to the eye, this dust will vary the capacity as it accumulates.

Again, the cast condenser requires a high degree of shielding, and its eddy current losses, due to so much metal serving only as support and not as true plate surface, add to the losses.

A third type of spacing can be used by cutting grooves into spacing pillars, or posts, into which the plates can be set with remarkably accurate spacing and with proper mechanical strength. This system is superior in its economy and efficiency if the plates are properly fixed in the grooves.

The proper design depends upon the method of fixing the contacts so positively that surface contact resistance is avoided.

For the rotor element, either die casting or washer spacing can be used. A few are made in which the rotor plates are set in position and the hot metal poured into a mould to form the center shaft.

In general, we may say that the conduction current losses due to washer spacing for either stator or rotor will be small, but the accuracy of the spacing will be difficult if washers are used for the stator. Every rotor shaft or bearing will eventually wear or have some parallel plate error, and an ordinary allowance can be made for this occurring on the rotor if the stator plates do not vary also. In short, by keeping the accuracy of spacing in the rotor, we could reduce the spacing to half of that required for

washer spacing in both rotor and stator and hence secure high capacity for the amount of plate surface used.

The real difficulty in condenser design is in arranging the support of the rotor and stator and in insulating them from each other. This involves the utmost mechanical strength and is most commonly attained by making the frame a part of the stator system and insulating the rotor by means of a metal bushing set in an end plate of insulation.

Three standard ways of doing this are used, and in each case there are decided electrical disadvantages. In the first case, where the end plates are large insulating masses, the dielectric hysteresis losses are generally considerable. When the surface of the insulator is large, the possibility of conduction across the surface is greatly increased. In the second case, the bearings are supported in such a way that the bushing becomes part of the dielectric and suffers also by having a large metal-to-insulation contact surface, thus increasing the dielectric losses. In type three, the insulation design is good, but the mechanical ruggedness is low. But in all these types the capacity of the operator's hand is carried to the dial by the rotor shaft and is bound to cause some body capacity effects in tuning regardless of shielding.

It is therefore desirable to reverse the usual procedure and instead of "grounding" the stator, to ground the rotor. This means that the stator is insulated from the frame. The frame can then be attached to the panel and by grounding will not be influenced by any "body capacity" brought near the panel. This is a highly important feature in tuning long dis-

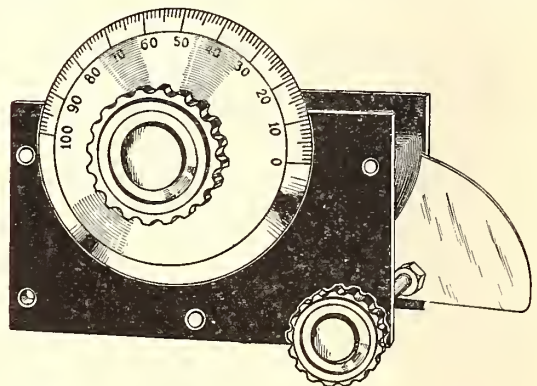

PLATE VERNIER

This design illustrates a simple method of getting a vernier effect by the use of a single plate on a second shaft



tance stations where the signal current is so weak that any variation of wavelength in the secondary or primary due to stray capacity fields will cause the desired station to fade out when the adjustment is fixed and the hand removed from the dial. To hold the station when the wavelength setting has been made it is therefore necessary to ground every part which may directly or indirectly be affected by body capacity. This can only be done by grounding the stator. Shielding does not entirely accomplish the desired end if the stator and frame are grounded, since the shaft of a rotor is part of the high potential side and passes through the shield and panel.

Another feature of design which is serious in the grounded stator type is the method of making contact with the moving rotor. If contact is made by friction, the amount of bearing surface is so small that a film of oil or dust or other foreign matter creeping into the bearing causes a high resistance. To avoid this unusually wide bearings must be used or a lead of flexible wire soldered to the rotor and carried to some connecting point.

This point brings up the subject of counter balancing. A condenser bearing gradually loosens with wear and can eventually become so loose that the rotor will slip around due to its own weight when the semi-circular plates are not at perfect balance.

Thus, great difficulty is caused in using a loosened condenser mounted with the shaft

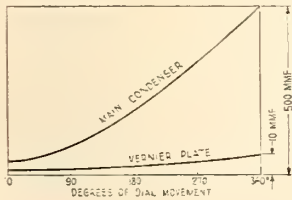

Note that although the ratio of the separate vernier plate to the main condenser is about 50 to 1 at maximum it is less than 4 to 1 at minimum settings, due to the high minimum capacity of this condenser design

horizontal on the panel as is generally the case. To overcome this objection some manufacturers place a counter-weight of moulded lead on the rotor so that even if the bearings loosen, the adjustments will not be altered by gravity. Other manufacturers resort to "two-side" construction, dividing half the rotor and half the stator plates symmetrically in opposite sides of the rotor shaft. Thus the same objective is attained. Both methods, however, add to the cost of the condenser, and its bulk, and make its minimum capacity high. Instead of three stator support rods as many as five or six

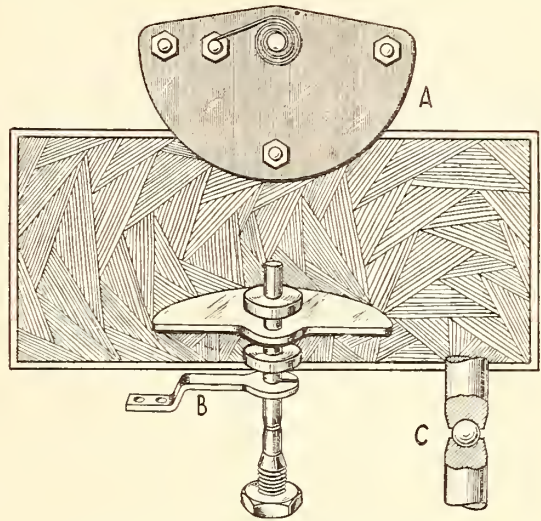

THREE TYPES OF ROTOR CONNECTIONS

- A—Pig-tail connection used for many rotor contacts
- B—A friction "pig-tail" spring which has a very good surface contact. The parts are moved open to show the relative positions
- C—A ball bearing which can be used on rotor-grounded condensers. This affords a perfectly centered bearing not subject to end play

posts are required with the "two-side" construction, multiplying the spacing problem proportionately. The weight of the stator, when counter balanced, is nearly doubled. All this can be avoided by placing a friction sleeve on the rotor shaft. By using a slotted sleeve, practically even and permanent pressure is secured which avoids any possible slippage from gravity.

A debatable issue is involved when the question of verniers is brought up. An efficient condenser which has a firm, even bearing requires no vernier when used by an experienced operator. Because some types of receivers, such as regenerators, require very critical tuning, vernier devices are often used. The vernier may take the form of a second condenser of one or two rotor plates built on the frame with the main condenser. It may also take the form of a gear system attached between the rotor control and the rotor shaft.

With the separate condenser vernier there is introduced a double electrostatic field—such that when the main condenser is set the small condenser may do more than vernier—it may increase or decrease the first capacity far out of proportion. What is more serious is the necessity for a more complicated shielding and insulating system. The cost is considerably increased and the design mechanically less

rugged in all cases, since one shaft must be contained inside the other shaft and must be fairly loose to operate at all. Possibility of wear or disalignment of plates can easily occur.

A mechanical vernier is preferable. By suitable gearing, a real vernier ratio is secured. A true micrometer effect is determined only by the gear ratio. With the separate condenser vernier, the ratio of increase is too low. Thus if the maximum capacity of the large condenser is 500 mmf. (micro-microfarads) and the maximum capacity of the vernier is 10 mmf., the ratio is 50 to 1, which is good. Usually, however, the interacting capacity of the vernier often runs up to 50 mmf. while in many condensers of this type the larger units hardly reach 400 mmf. Thus, in practice, the ratio becomes 400 to 50 or 8:1 which is not sufficiently large. By a mechanical vernier, such as a rubber roller on the edge of a 3-inch dial, the ratio is about 6:1 which is also too low. The best solution is by using a gear in which a single main condenser is varied by a ratio of turn of 50 to 1 or higher. This, however, is not altogether desirable for quick tuning and, in general, most experienced radio operators do not like verniers preferring to use a circuit in which a vernier is not required. This is worth careful study. Specially designed vernier dials are on the market which afford an 80:1 ratio, and, when mechanically rugged, they offer an ideal solution of vernier controls.

#### WHAT MATERIALS ARE BEST FOR CONDENSERS?

WE MAY now discuss the various types of materials used in the manufacture of the condenser. As the condenser should be light, some metal such as aluminum is almost universally used. The resistance of aluminum is almost as low as that of copper. Plates of aluminum, if more than .0025 inches thick, are reasonably strong and will not be easily bent. They are also springy enough to stay in shape even if accidentally pressed or hit, if made from hard stock. Aluminum also makes a good cast frame. Sheet aluminum is almost universally used for the plate material. It can be polished, and if made in constant thickness and of high purity it is satisfactory in all respects. Plates of brass and some other metals may be nicked but this is not necessary if the spacing is greater than .05 inches as the possibility of dust short circuiting the plates is very small. Aluminum is not easily corroded under ordinary conditions, and the surface resistance is not

an important factor. For the rotor shaft, a good grade of case-hardened steel is desirable. The end bearings should be of dissimilar metal from the shaft and preferably bronze or brass. Spacers should be about  $\frac{3}{4}$  of an inch in diameter for the rotor. On the three-post types, used for stator spacing, washers of at least  $\frac{3}{8}$ -inch diameter are desirable. The bearings must always be made of the best steel and brass and where pressure is exerted, be so assembled that the wear is properly taken up by adjusting screws so that after long use the tension or position of the plates can be restored.

"Pig tail" connections for the moving element contact are generally made of braided copper wire of about twelve or more strands. If ribbon wire is used, it must be very flexible and not subject to twists when coiling or uncoiling; or a flat connector like a watch-spring may be used.

It is difficult to specify the best kinds of insulation without treading on trade names of different manufacturers. Phenol compositions have good insulation characteristics if not in the electrostatic field, but any solid material is bound to cause resistance in this respect. Fibrous materials rank somewhat below the phenolic compounds. Hard rubber of pure composition is particularly good for supports and insulation. A good design calls for the smallest possible contact with any solid insulation. On the other hand a fixed condenser uses a good deal of insulation, as the dielectric and the resistance characteristics then play an important part. Porcelain is electrically good but mechanically poor owing to its brittleness.

Back of all these factors in design, workmanship and materials is the basic efficiency of the condenser—resistance. No beauty of assembly, no perfection of material or convenience of design can offset resistance effects. Furthermore, if the condenser has only a low range of capacity variation it is inefficient and if it has proper maximum range but excessive bulk it is also undesirable.

The measurements of the resistance of a condenser are extremely difficult. The best way is by a comparison test, using as the standard a special condenser with plates suspended by silk threads and all stray field effects carefully isolated. Such a measurement involves very delicate and accurate devices and considerable engineering skill. The rating given must be based upon the reputation of a recognized authority.





# What Our Readers Write Us



## *A Bouquet for the Broadcasters*

Editor, "RADIO BROADCAST"

DEAR SIR: I am deeply impressed by the requests which come so often over the radio for listeners-in to write to the artists, lecturers, singers, and others who entertain the unseen audience.

It seems a small matter to write such letters, and I have written a great many; but I think most radio fans realize that it is impossible to write as many as the people who entertain would hope to get, and I should like, through your magazine, to express my appreciation of the enormous trouble and work undertaken by these stations, which give us such a vast variety of good material suited to every taste. As I cannot listen to the radio and write letters all the time, I ask that you may find room for this letter of general appreciation in your magazine.

I have just returned from a trip to London, where broadcasting is paid for through a license which every person who owns a receiver must possess, and the entertainment provided, both in variety and quality, as well as in amount, is insignificant compared with the service given in this country without pay. I am sure that the letters which the stations receive do not adequately represent the gratitude of people who own radio receiving machines.

Very truly yours,  
F. N. DOUBLEDAY.

## *A Report on the Grimes "Inverse Duplex"*

A MAGAZINE for and about radio is in somewhat different relation to its "Dear Readers" than most other periodicals, in that there is more correspondence with the editor. There is quite a bit of familiarity and good fellowship. There are many bouquets received and some brick-bats—which we are happy to say are much in the minority. We do try to make our magazine helpful as well as entertaining, and we like to know that our efforts meet with your approval. For this reason we are always glad to receive letters such as this one, from those who have successfully followed the instructions in our "How to Make It" articles.

GENTLEMEN:

I wish to extend my thanks for your article in the April number of RADIO BROADCAST. "1,300 Miles With a One Foot Loop," and especially for the

wiring diagram of the Grimes Inverse Duplex receiver. Shortly after reading the article I set about building an Inverse Duplex. I have had several types of receivers, including crystal detector, ultra-audion, plain VT detectors, and three-circuit regenerators, including variometer and variocoupler tuners and triple spider-web tuners and this set (Inverse Duplex) sure has them all beat. Although on the loop it is not quite so loud as some of the other sets with a two-stage A. F. amplifier, the ease of tuning, freedom from interference and other noises more than make up for the slight decrease in the volume. Several of my friends have heard it and say it is better than any they have ever heard.

In the four weeks I have been using this outfit there has been only one night when I could not hear anything. One night when static was quite bad on outdoor aerial outfits, I could cut through to WGY 1,000 miles with very little annoyance from static, on the loop.

Thanking you again for the article, and for all the other interesting articles in your magazine I am

Sincerely yours,  
ARTHUR E. TABRAHAM  
Bloomington, Ill.

## *Selling Records by Radio*

AS SOON as someone suggests selling by radio, most thumbs go down. However, it is being done, and, to a great extent, being so well done that we are all learning to like it. Good publicists have been able to "sell" religion by making it entertaining; plays and operas have been "sold" to the public and lately we find that the large movie houses can sell their entire program by letting the radio audience hear a part of the good music that drowns the click of the projector as the silent drama is screened. In the accompanying letter our correspondent outlines a very practical plan, which, it would seem, could be brought into action with satisfactory results.

DEAR SIR:

I wish to make a suggestion of a plan whereby radio and the phonograph might be made to cooperate with each other instead of conflicting and competing as they do now. The history of the telephone and the telegraph shows us that one can never entirely eliminate the use of the other, but that the development of the entire field of use for both

together has made the share of business of each invention much greater than if one interest had entirely eliminated the other.

At present the phonograph people have the best talent in the country under contract and are able to pay large sums for good entertainment. The broadcasting stations are still furnishing high class entertainment, but when performing before the microphone has lost some of its novelty the problem of paying the artists and collecting from the radio public will have to be solved.

My plan is this: Use radio broadcasting to advertise phonograph records. I don't mean to broadcast phonograph music by any means, for everyone knows how little satisfaction there is in tuning a radio set just to get a poor reproduction of phonograph music that you can listen to first hand with no trouble at all. But why cannot the microphone of some good broadcasting station be installed in the studio where records are being made by famous artists and give the radio public a free sample of what the next issue of records is going to be like so that they will want to go down and buy the record.

The movies are running short parts of films to advertise coming attractions, new foods are often advertised by free samples, the circus gives a free show or parade to advertise the main attraction, the music stores all have concert rooms to play the new records for prospective customers, so why shouldn't the record manufacturers avail themselves of the absolutely free means of handing out a sample of part or all of a few of their coming issues of records to many thousands at a time of a class of people that are all interested in good music and a large share of whom are owners of phonographs?

Very truly yours,

FRED W. TEMPLE  
Lenwood Hospital  
Augusta, Georgia.

### *Playing the Game*

IT IS doubtful that the devotees of any pastime are more sportsmanlike than radio enthusiasts. It is true that, for a time, there was, and in some few places there still is, a squabble between the folks interested in broadcast reception only, and those out and out brass-pounders who are now known as "hams." Wherever any ill-feeling is found, it is more than likely to result from a mutual misunderstanding and it may be smoothed over by a chat. Such chats usually require more than average goodwill and gumption on the part of one of the people concerned and there are not enough of such people. The suggestions made by our correspondent, who signs himself, "A Ham," may make such chats unnecessary and life more livable for all of us.

DEAR SIR:

Within the past few months we have seen a great many receiving circuits exploited in radio magazines and radio sections of the newspapers. Some of these circuits are nothing more than modifications or complications of circuits that have been known for some time. In many instances their chief advantage consisted in giving the magazine or paper something to describe and radio dealers something to sell. When the time came for performance, many of these outfits produced nothing but disappointment. Many novices attempted to construct these circuits and after they have invested their good money for the purchase of parts to build up these so-called phenomenal receivers, found that it was not difficult to eliminate one half or more of the parts and secure about the same results, and by so doing, getting back to the original circuit of which the new circuit was a complication.

It happens that a great many of these receivers are of the radiating type, that is, they are made in exactly the same fashion as radio telephone transmitters except that they are made to operate on considerably less power. The fact that they do transmit cannot be questioned.

The efficiency of these receivers is obtained in a manner that in the long run can do nothing but harm the radio business. This is particularly noticeable in the case of the Reinartz and the Flewelling circuits. The case of the single-circuit regenerative receiver has received so much attention that it is unnecessary to discuss it further here, but in comparison to these other receivers it is actually a *mild* transmitter.

If radiating receivers are used close to each other, we find that a great deal of whistling results. Take for instance an apartment house with five or six antennas all leading to regenerative receivers that are in almost an oscillating condition. Suppose two or three of them are tuned in on the same distant broadcasting station and for some reason or other the signals from this station become weak. The operators of the three receivers begin very delicate adjustments to build up this signal strength and in doing so one of them may reduce his wavelength; another may go up on his; and the third may satisfy himself with increasing his regeneration to the point of oscillation. Nothing more than a din is the result. Sooner or later this type of receiver will be a thing of the past, for there are indications, even now, that other types of receivers may be made which will perform equally as well without causing this interference. In the meantime *the sportsmanlike thing to do is to manipulate your receiver in such a manner as to permit your neighbors to secure the benefits from theirs that you would like to receive from yours.* This may be done if the receiver is kept well below the oscillating condition.

One serious cause of disturbance is utilizing what is called "zero beat" reception. Zero beat reception



is brought into play by getting the regenerative or plate circuit in exact resonance or tune with the incoming signals and is a very difficult method to employ satisfactorily. You can recognize the fact that you are employing zero beat reception when tuned to a given station, you find that by moving your wavelength dial a hair's breadth to the left or right, you are greeted by a whistle. That whistle means that you are going slightly above or slightly below the wave of the transmitting station and the wave of your regenerative receiver combines with the incoming wave from the transmitter and produces what is called a beat note. This beat note is picked up by other receivers in your neighborhood and if these receivers are connected to amplifiers and loud speakers, the result is a pronounced shriek which is doing more to injure radio than any other agency.

Have you ever invited a number of friends in to listen to a concert in which you thought they would be particularly interested? For a while the magic music may be delightful and at about the time that everyone concludes that radio is a very wonderful

thing, one of the shrieks to which we are referring comes out of the loud speaker. Those who are unfamiliar with radio are astounded. Their eyes widen and it is not unlikely that someone will exclaim: "What is that horrible noise? If this is radio I'll take the phonograph."

There are two methods for eliminating this interference. The first is by operating your receiver below the oscillating point; the second is by adding a single stage of radio-frequency amplification before the detector. It is well, in determining upon the receiver you ought to build, to find out whether or not the circuit you contemplate employing will radiate. It is better to employ some circuit that will permit long distance reception without interfering with your neighbors, who in turn have the privilege of employing a similar arrangement to interfere with you and continued back-biting of this sort is as disagreeable to the innocent bystander as to the quarrelers themselves. *Will you do your share to make radio better for everybody?*

A "HAM"  
Chicago, Ill.



"IS IT PITTSBURGH, MR. GALLAGHER?" "NO, CHICAGO, MR. SHEAN"

Gallagher and Shean, the not unknown comedians, are here shown behind the scenes waiting for their act to go on, listening-in to some station, the exact location of which was not learned, owing to the fact that when the photographer left, they were still arguing as to whether it was Chicago or Pittsburgh

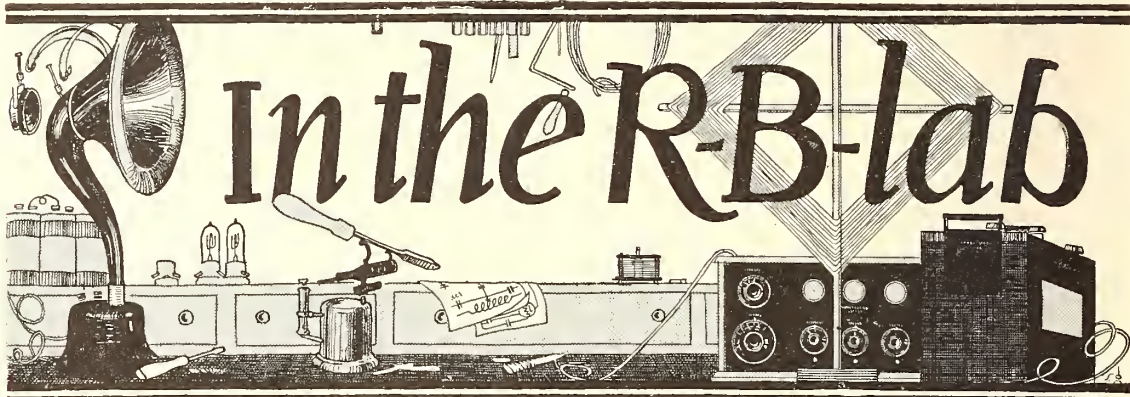

The "Lab" department has been inaugurated by RADIO BROADCAST in order that its readers may benefit from the many experiments which are necessarily carried on by the makers of this magazine in their endeavors to publish only "fact articles" backed by their personal observations.

Under this heading will also be published practical pointers, brief write-ups of interesting experiments, additions to and improvements on previously published circuits—in short, anything of genuine value and interest to the reader, which, due to the brevity with which it can be covered, does not justify a special article.

RADIO BROADCAST will be pleased to buy from its readers, at prices from three to five dollars, commensurate with the value of the data, kinks, devices, original ideas, etc., with photographs if possible, which the editor may consider eligible for this department.

Address all communications to the R. B. Lab EDITOR.

## PLAYING WITH THE GRIMES CIRCUIT

THE Grimes Inverse Duplex receiver, which has been described in several past issues\* of RADIO BROADCAST, has proven on merit the most popular of the many reflex circuits. However, there is little doubt that the original circuit admits of considerable improvement, and the attention of not only the inventor but of individual experimenters has been devoted to this effort. Experiments by this department have resulted in data which will be of interest to the reader engrossed in the complications of this ingenious circuit.

The RADIO BROADCAST experiments were roughly divided into two parts: ascertaining the possibilities of different kinds of tubes in detecting and amplifying combinations, and investigating the possibility of increased signal strength through regeneration.

In all cases it was found that reception was much improved by the inclusion of a grid condenser and leak in the detecting circuit, rather than the direct metallic connection indicated in many diagrams.

The following combinations were attempted,

\*For circuits and further constructional data, see the April, July, August, and September issues of RADIO BROADCAST.

reception being effected on the small two-foot loop shown in the photograph (Fig. 1), all comparative tests being made on Station WOR, fifteen miles away:

1. Using three UV-201's for both amplifiers and detector: The result was a very stable set, and reception was little affected by adjustment of the limiting potentiometer. Signal strength was fair in the headphones, but weaker than in any of the succeeding experiments.

2. Using 201's in the amplifier and a UV-200 in the detector: Signal strength was considerably improved; but the set became more critical, and howled unmercifully on certain adjustments. This might have been obviated, however, by biasing the amplifier tubes.

3. Using UV-199's throughout: Signal strength was equal to test number two, but best results were not secured until the tubes were varied from detector to amplifier sockets and the most efficient combination determined.

However, distortion was particularly noticeable with these tubes when an amplifying plate voltage over forty was employed, and sixty to eighty volts was required for the highest intensification. Biasing the grids of both amplifying tubes with three volts negative, improved matters, reconciling quality to amplification.



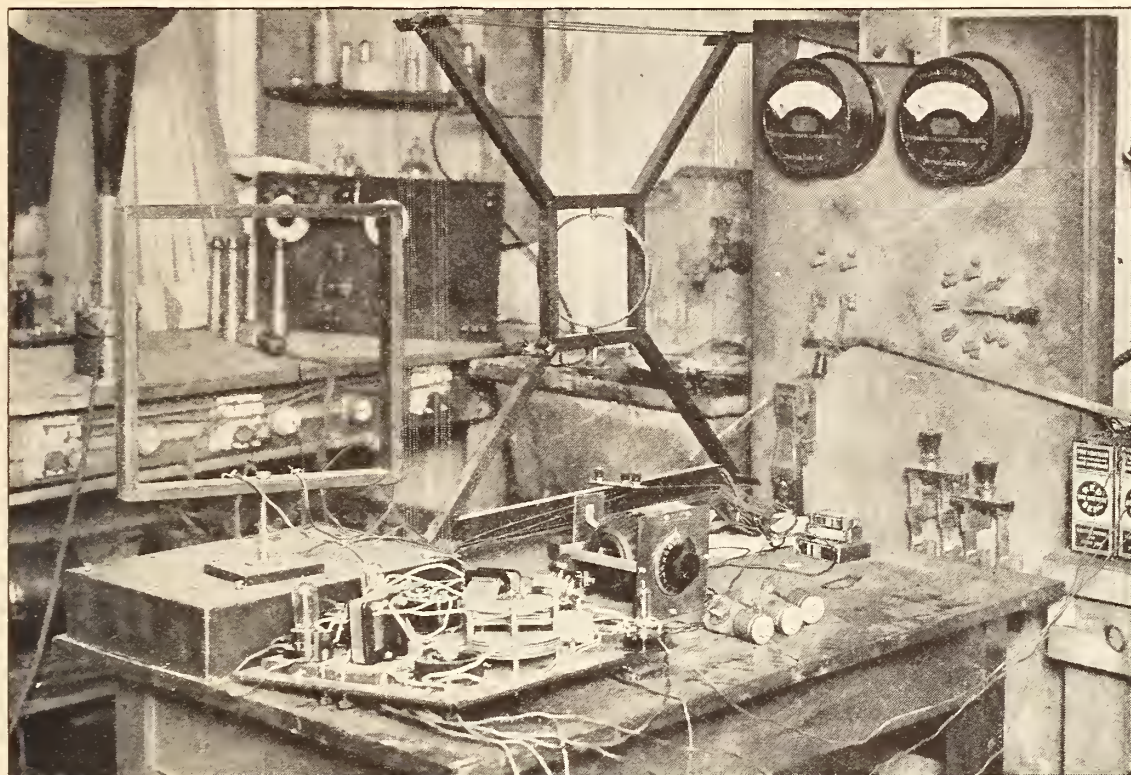

FIG. 1

Trying a plate variometer in the detector circuit of the Grimes receiver. UV-199's are in the amplifying sockets and a W. E. 215-A in the detector socket

The limiting potentiometer was here found quite necessary.

4. Using UV-199's for amplifiers and a 215-A—(W. E. peanut tube) for the detector: It was first discovered that these last tubes are not altogether uniform. One of three, however, proved an excellent detector, and this combination gave results superior to any of the preceding experiments. Signals were sufficiently loud to operate a small loud-speaker, though on more distant stations we should advise an additional stage of separate A. F. amplification.

On each of the foregoing combinations, regeneration was attempted by both the tickler feed-back and variometer methods. The former system was found unstable when it had any effect whatever, and results did not justify the expense and clumsiness of the extra winding on the loop.

However, using a standard variometer in the plate circuit of the detector, in experiment three, had a marked effect of regeneration, and signal strength was considerably improved. In tests one and two, it proved critical and un-

stable, while in the last it produced little or no effect.

From the foregoing experiments, the following conclusions may be arrived at:

1. A grid condenser and leak are desirable to the efficient operation of the Grimes circuit.
2. Howling and general instability of the circuit can be reduced and reception improved by biasing the grids of the amplifying tubes. (See page 123, June 1923 RADIO BROADCAST.)
3. Certain qualities in some detector tubes antagonistic to the best reception can be remedied by the use of a plate variometer.
4. The plate variometer is especially valuable with the UV-199 tube.
5. On the whole, an extra regenerative system in combination with the Duplex is neither desirable nor practicable.

#### MAKING YOUR GRID-LEAKS

(Photograph and data contributed by Carter Fiske)

**G**RID-LEAKS of different values are essential to the most efficient operation of radio receiving circuits, and poor results with many homemade regenerative sets have been

traced to an improper grid adjustment. The enthusiast who is becoming an experimenter should be equipped with the means of varying the grid-leak on the various tubes and sets with which he is experimenting. A variable leak is of course one solution, but many of these are unsatisfactory, and as there are often several sets in the shop, the most economical plan is to supply one's self with a dozen or so homemade fixed resistances.

A very efficient leak can be made by coating a small piece of card or bristol board with Higgins' Waterproof 'White Label' India ink. Different resistances are obtained by repeated coatings of ink.

The bristol board is cut into small strips an inch and a half long by a quarter of an inch wide. They are coated on one side to within an eighth inch of each end by applying the undiluted ink with the quill furnished on the stopper (Fig. 2). The resistance of three quarters of one inch of single coating is approximately 5 megohms (5,000,000 ohms); of two coatings,  $2\frac{1}{2}$  megohms; five coatings, 1 megohm, and so on. The experimenter is advised to make up a collection of resistances from 5 megohms to one half megohm.

The exact resistances of the leaks can be determined if the enthusiast possesses a microammeter or a galvanometer calibrated in fractions of an ampere. It will merely be necessary to connect the leak in series with a high-voltage battery (from one hundred to



FIG. 2

Making the grid leak. The India ink is applied to the surface of the bristol board, the number of applications determining the resistance

one hundred and fifty volts) and the meter, read the current indication, and apply Ohm's law (see article beginning on page 496, this issue) which states that the resistance is equal to the voltage divided by the current.

In a large laboratory, the resistance of the grid-leak would be measured directly by a very interesting instrument, an English invention, known as the Megger. This instrument is fundamentally nothing more than a D. C. meter reading in ohms directly, rather than volts or amperes. The Megger supplies its own potential by means of a small hand-driven, 250-volt generator. The ingenious part of the instrument exists in the differential winding of the meter which automatically compensates

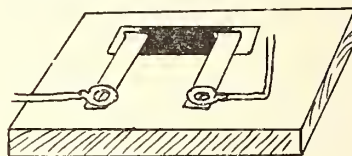

FIG. 3  
A simple mounting  
for the grid leak

for any variation in the voltage caused by the inconstant speed of the generator. If a grid-leak is connected to a Megger of the proper range, and the handle turned, the needle will indicate on the scale the exact resistance of the exterior circuit.

The ingenuity of the experimenter will devise numerous ways of mounting the India ink resistance. A convenient method of mounting is suggested in Fig. 3, where the resistance element is slipped under two brass or copper strips screwed to a small block, base, or panel.

#### BUILDING YOUR OWN LABORATORY

**A** WELL equipped radio laboratory is the ambition and dream of the true fan. A laboratory, however, unlike Aladdin's palace, is not to be built overnight. Rather the various tools and equipment are slowly accumulated with experience and as the pocket-book allows. But the building of a laboratory can be greatly facilitated if its acquisitions and purchases are effected with the advice and under the supervision of those who have paved the way.

RADIO BROADCAST plans to devote a section of this department to the interest of those readers who are slowly adding to their equipment, laying the foundation of a genuine radio lab. Every month, if space permits, one or two instruments or tools well within the financial resources of the average reader will be



suggested as additional equipment, and their functioning or use carefully explained.

Fig. 4 shows two pieces of laboratory equipment, a small hand-drill and a wet cell, the first being indispensable for rapid and accurate construction, and the latter most useful as an *always ready* auxiliary or spare battery. The hand-drill will cost from two to three dollars, and should be purchased along with an 18 and a 27 drill. These sizes will pass respectively, an 8 and a 6 screw, the two sizes most commonly encountered in radio work. The hand-drill may be used on wood, bakelite, hard rubber, etc., and on metal. It is equally useful in drilling cabinets, panels, or brass and steel supporting brackets. It is many times more rapid than the cumbersome brace and bit.

The wet cell equals in voltage the dry cell, and in emergencies it may be temporarily substituted for the latter. However, it is not recommended for continual service due to rapid polarization, an effect that renders the battery inoperative.

The wet cell costs about seventy-five cents, and renewals (zinc and sal-ammoniac) perhaps fifteen cents. When it is desired to use the



FIG. 4

Two useful additions to the amateur laboratory

battery, six ounces of sal-ammoniac are dissolved in the jar two-thirds filled with water. It is suggested that when the cell has done its duty—perhaps rescued a concert which a failing dry cell would no longer bring in well—that the solution be bottled and the carbon cylinder and zinc rod dried. The battery is now ready for the next emergency, and with such care renewals will not be necessary for several years.

### Supplemental List of Broadcasting Stations in the United States

LICENSED FROM JULY 14 TO AUGUST 7 INCLUSIVE

CALL SIGNAL	STATION	FREQUENCY (Kilocycles)	WAVE-LENGTH	POWER WATTS
KFBC	Nielson Radio Supply Co., Phoenix, Ariz.	1260	238	10
KFIY	Brott Laboratories, Seattle, Wash.	1270	236	15
KFIZ	Daily Commonwealth, Fond du Lac, Wis.	1100	273	100
KFJC	Post Intelligencer, Seattle, Wash.	1290	233	100
KFJF	National Radio Mfg. Co., Oklahoma City, Okla.	1190	252	20
KFJH	The Sugar Bowl, Selma, Calif.	1100	252	10
KFJI	Liberty Theatre, Astoria, Ore.	1190	252	10
KFJK	Delano Radio & Elect. Co., Bristow, Oklahoma.	1290	233	100
KFJL	Hardsoog Mfg. Co., Ottumwa, Iowa.	1240	242	10
WSAU	Camp Marienfield, Chesham, N. H.	1310	229	10
WSAW	Curtice & McElwee, Canandaigua, N. Y.	1090	275	100
WTAF	Gallo, Louis J., New Orleans, La.	1240	242	20

#### DELETIONS FROM JULY 1 TO JULY 31

KFAT	Eugene, Ore.	WMAD	Rockport, Mo.
KDFD	Casper, Wyo.	WMAW	Wahpeton, N. D.
KFIC	Denver, Colorado	WNAB	Bowling Green, Ky.
KFJB	Marshalltown, Iowa.	WNO	Jersey City, N. J.
WAAQ	Greenwich, Conn.	WPAS	Amsterdam, N. Y.
WABA	Lake Forest, Ill.	WPI	Clearfield, Pa.
WCAZ	Carthage, Ill.	WQAJ	Ann Arbor, Mich.
WFAG	Waterford, N. Y.	WQAK	Dubuque, Iowa.
WGAX	Washington C. H., Ohio.	WQAT	Richmond, Va.
WIAV	Binghamton, N. Y.	WRAN	Waterloo, Iowa.
WIAW	Saginaw, Mich.	WSAA	Marietta, Ohio
WIZ	Cincinnati, Ohio.	WTP	Bay City, Mich.
WJAJ	Dayton, Ohio.		

# New Equipment

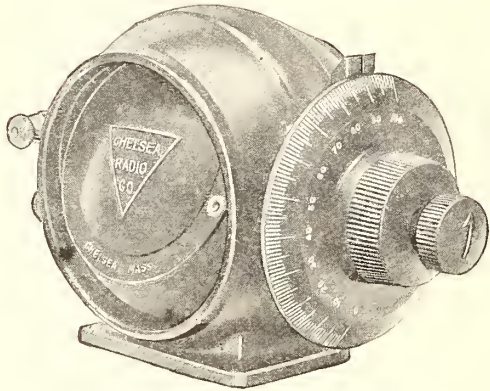

**A VERNIER VARIOMETER**

Made by the National Chelsea Radio Corporation. It has a wide inductance range, is ruggedly built, and is intended for either panel or table mounting. Price, \$8.00

**EVEREADY "THREE" RADIO BATTERY**

This battery merits every radio set user's attention. It may be used as an A battery for receivers employing UV-199's, as a B-battery booster for any tube set, and as a C battery for any amplifier. Size 4" x 3" x 1 3/8", 14 oz., 3 to 4 1/2 volts. The booklet describing the uses of this little battery may be had from the National Carbon Company, Inc., Long Island City, N. Y. Price, 70 cents

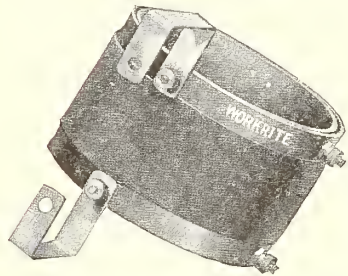

**A TUNED R. F. TRANSFORMER**

Designed for use in neutrodyne circuits, but suitable for any arrangement employing tuned radio frequency. Information regarding its use in various circuits may be had from the

manufacturers. Workrite Manufacturing Company, Cleveland, Ohio. Price, \$2.00

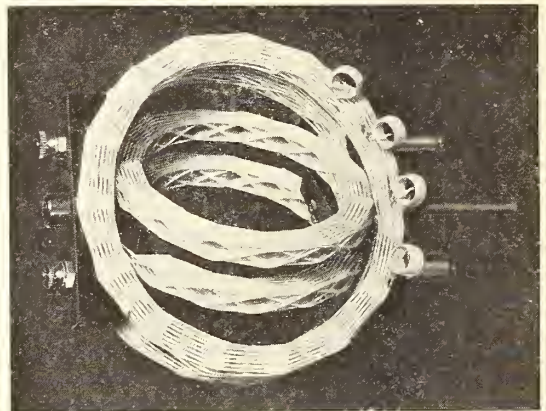

**THE R. M. C. VARIOCOUPLER**

This is one of a number of tuning instruments made by the Radio Manufacturing Company, of Springfield, Massachusetts. With a pair of variometers of similar construction, this variocoupler may be used to advantage in the construction of a good three-circuit receiver

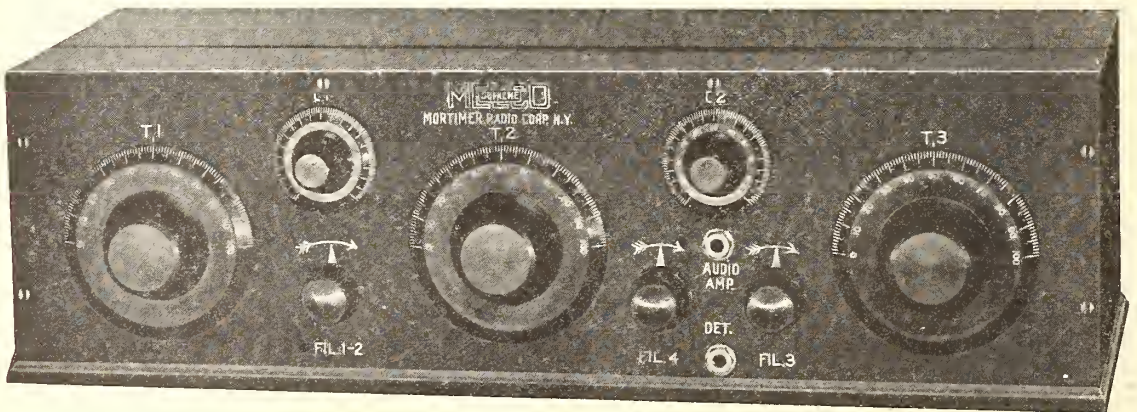

**A BROADCAST RECEIVER EMPLOYING THE NEUTRODYNE PRINCIPLE**

Two steps of radio-frequency amplification, detector, and one step of audio gives enough volume to operate a loud speaker. The tuning is accomplished by special Telos variometers. Dials C<sup>1</sup> and C<sup>2</sup> control the neutrodyne condenser, in order that the various values of capacity in the tubes employed may be compensated for





## “What panel shall I use?”

ONE of the first questions you probably will ask yourself when you get ready to build your radio set will be about the choice of a good panel. Your answer will determine, to a large extent, the efficiency of your set.

Of course you want a panel that has superior insulating properties. Celoron Radio Panels are used by fans who appreciate the value of a good radio panel. They have high dielectric strength and great volume and surface resistivity. Celoron panels are uniform in quality, and do not warp or crack.

You will find Celoron panels easy to saw, drill, and tap. They engrave evenly without feathering, and enable you to build a set that is neat and attractive as well as efficient.

### Approved by Uncle Sam

Celoron Radio Panels are approved by the U. S. Navy Department Bureau of Engineering and the U. S. Signal Corps. Many of the leading manufacturers of radio equipment use Celoron in their standard parts.

To radio dealers: Send for special dealer price list showing standard assortments

## Diamond State Fibre Company

BRIDGEPORT

(near Philadelphia)

PENNSYLVANIA

BRANCH FACTORIES AND WAREHOUSES

BOSTON

CHICAGO

SAN FRANCISCO

Offices in Principal Cities

In Canada: Diamond State Fibre Company of Canada, Limited, 245 Carlaw Ave., Toronto

Each panel is wrapped separately in glassine paper and carries complete instructions for working and finishing. Ask your dealer for one of the following sizes:

1—6 x 7 x $\frac{1}{8}$	5—7 x 18 x $\frac{3}{16}$
2—7 x 9 x $\frac{1}{8}$	6—7 x 21 x $\frac{3}{16}$
3—7 x 12 x $\frac{1}{8}$	7—7 x 24 x $\frac{3}{16}$
4—7 x 14 x $\frac{3}{16}$	8—12 x 18 x $\frac{3}{16}$

We also furnish Celoron in full-sized sheets and can cut special sizes if desired. If your dealer has not yet stocked Celoron panels, ask him to order for you, or write direct to us. Indicate by number the size you want.

### Send for free booklet

Our booklet, “Tuning in on a New World,” contains a list of the leading broadcasting stations in the United States and Canada, several efficient radio hook-ups, and an explanation of the symbols used in radio diagrams. Write at once and be sure of getting yours before the supply is exhausted.



CONDENSITE  
**CELORON**  
 STANDARD RADIO PANEL

New Equipment--Continued



FILAMENT LIGHTING FROM A LAMP SOCKET  
 Is now possible where alternating current of 110 or 220 volts is available. This little machine will furnish enough current for the lighting of more than a dozen 6 volt tubes. It is being included by several manufacturers of complete receivers as standard equipment and is the first machine to be marketed as a substitute for the storage battery. Simplex Electrical Laboratories, Inc. 144 Livingston St. Brooklyn, N. Y.

# The Grid

## QUESTIONS AND ANSWERS

The Grid is a Question and Answer Department maintained especially for the radio amateurs. Full answers will be given wherever possible. In answering questions, those of a like nature will be grouped together and answered by one article. Every effort will be made to keep the answers simple and direct, yet fully self-explanatory. Questions should be addressed to Editor, "The Grid," RADIO BROADCAST, Garden City, N. Y.

### A TUNED PLATE CIRCUIT

*Will you please publish a hook-up containing the following equipment, and explain the functioning of each piece of apparatus:*

- One variometer*
- One 43-plate condenser*
- One stage tuned radio-frequency amplification*
- One stage audio-frequency amplification*
- About how far should such a set receive?*

C. P., Norristown, Pa.

WE APPEND the diagram which our correspondent desires, in Figure 1. It is suggested that the instruments be mounted in the left to right order indicated in the diagram, and on a panel not shorter than twelve inches.

C<sub>1</sub> is the 43-plate condenser which tunes the wavelength to which the loop responds. This last is simply constructed and the reader is referred to this department for May, in which clear directions are given for building it.

Potentiometer R<sub>3</sub> varies the charge on the grid of the first tube, according to the position of the slider or knob, which may be varied between the positive and negative terminals of the A battery. This variation is called biasing and permits the radio-frequency tube to be operated at its most efficient grid potential, and results in maximum amplification with a minimum of distortion.

Variometer V comprises the tuned plate circuit in which the radio-frequency amplification is effected in a manner not easy to explain to readers unfamiliar with radio theory. Its functioning is, perhaps, most easily disposed of by stating that it offers infinite impedance to the currents of the

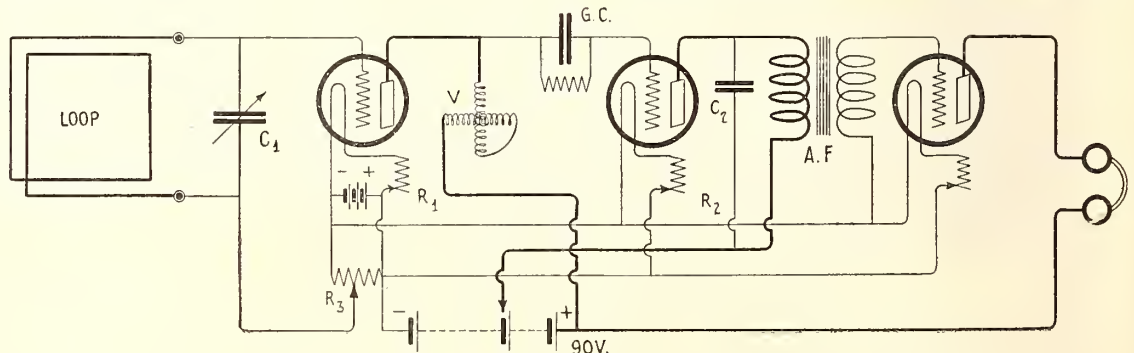

FIG. 1



# Magnavox Radio

## Reproducers and Amplifiers

IT has been the dream of every Radio user to own in one unit a Power Amplifier and electro-dynamic Reproducer, thus insuring perfect radio reproduction. The new instruments of the unit type here illustrated in one and two stages of amplification may be had through dealers everywhere.



*New Magnavox Combination Set A1-R*

There is now a Magnavox for every receiving set. The full line embraces:

### *Magnavox Reproducers*

R2 with 18-inch curvex horn . . .	\$60.00
R3 with 14-inch curvex horn . . .	35.00
M1 with 14-inch curvex horn. Requires no battery for the field . . . . .	35.00

### *Magnavox Combination Sets*

A1-R consisting of electro-dynamic Reproducer with 14-inch curvex horn and 1 stage Amplifier . . . . .	59.00
A2-R consisting of electro-dynamic Reproducer with 14-inch curvex horn and 2 stage Amplifier . . . . .	85.00

### *Magnavox Power Amplifiers*

A1—new 1-stage Power Amplifier . . .	27.50
AC-2-C—2-stage Power Amplifier . . .	55.00
AC-3-C—3-stage Power Amplifier . . .	75.00

The new Magnavox semi-dynamic Reproducer M-1, designed for dry battery receiving sets, is also of great interest to radio users. Write for complete catalog.

**THE MAGNAVOX CO., Oakland, Cal.**

New York Office: 370 Seventh Avenue



PERKINS ELECTRIC CO., LTD., MONTREAL, CANADIAN DISTRIBUTORS

wavelength to which it is tuned, with the result that the oscillations which would ordinarily return through the variometer are forced upon the grid circuit of the succeeding tube.

The grid condenser and leak (GC) function for the detector tube much after the manner of the potentiometer in the R. F. amplifier, and maintain the electrical condition of the detecting grid in the state most conducive to detection.

C<sub>2</sub> is a telephone bypass or shunt condenser of the usual type, generally .002 mfd. capacity, and may be purchased for thirty-five or fifty cents. It passes radio-frequency currents in the detector tube which otherwise would be impeded by the high reactance of the primary of the audio amplifying transformer. This passage of the R. F. current has a slight effect of regeneration, and while not altogether necessary on this type receiver, it often improves operation.

The audio transformer merely relays the output of the detector on to the amplifying tube, where it is intensified, and finally sent through the phones or loud-speaker.

The receiving possibilities of such a set rest largely upon the experience of the operator, and in the winter season reception distances may range anywhere from one hundred to a thousand or more miles.

WINDING SPIDER-WEB COILS

In the May, 1923, issue of RADIO BROADCAST appeared an article by Walter Van B. Roberts describing "A Single-Tube Loop Set in a Brief-Case." The article mentions that the grid and tickler coils are wound, spider-web fashion, "over three and under three." I should appreciate it if you would illustrate in a drawing just how these directions are to be carried out.

M. S., CONEY ISLAND, N. Y.

THE "over three and under three" method of winding can be used to advantage for any receiving set provided that the number of turns and diameter of the coils are suited to the wavelengths on which it is desired to receive. The accompanying illustration (Fig. 2) shows how the inductance is to be wound. Starting at the inside end of any one of the "spokes", the wire passes over three "spokes" (looking edgewise at the wheel or winding form) and then under three, round and round until the wire has packed up the required distance from the inside ( $1\frac{3}{8}$ " in the case of the coil described by Mr. Roberts). Nineteen spokes should be used, but if a form having greater or less than nineteen is more convenient, almost any reasonable number may be employed. Care should be taken, however, that the number of "spokes" is always divisible by three, plus one, i. e., ten "spokes" (nine plus one), thirteen "spokes", twenty-two, etc.

The winding form is generally made in one of two ways: it may be built up of wooden spokes (such as toothpicks) stuck into the edge of a small wooden or heavy cardboard disk; or, perhaps the more simple method, by cutting out the complete form from fibre or heavy cardboard, as Mr.



FIG. 2

Roberts did (see tickler coil in photo on page 18, May issue.)

Any one who contemplates winding his own spider-webs will do well to read the clear and detailed instructions on pages 428 and 429 of RADIO BROADCAST for March, 1923. In that case, 45 toothpicks were used, the wire being wound over two and under two.

A THREE-CIRCUIT LAYOUT WITH AMPLIFIER

Since becoming a reader of your excellent publication, I am contemplating the construction of a regenerative receiver built in such a manner that two stages of amplification can be conveniently added to the same at a later date. Will you kindly furnish a diagram of the wiring, as well as a drawing showing the approximate size of the panel and the placing of the various tuning instruments? I intend to use a variocoupler and two variometers. How many taps should there be on the variocoupler?

H. A. K., Fergus Falls, Minn.

IT IS suggested that H. A. K., and readers interested in similar apparatus, build the tuner and detector in a single cabinet, and later, if desired, the two steps on a separate panel and according to the instructions detailed in the article on amplifiers appearing in the July issue of RADIO BROADCAST. The circuit diagram, and the preferred order in which the instruments may be mounted, are shown in the Fig. 3 and Fig. 4, which also suggests the desirable dimensions for the panels.

The number of taps on the variocoupler will vary with the make, averaging, perhaps, ten. The better instruments are tapped in both units and groups of turns, necessitating two rows of taps and two switch levers, but eliminating the series antenna condenser.

This receiver is the renowned amateur standby and in the opinion of many operators, it is without peer for distance, loudness, and selectivity. It was a set of this type that won RADIO BROADCAST's "How Far" contest.

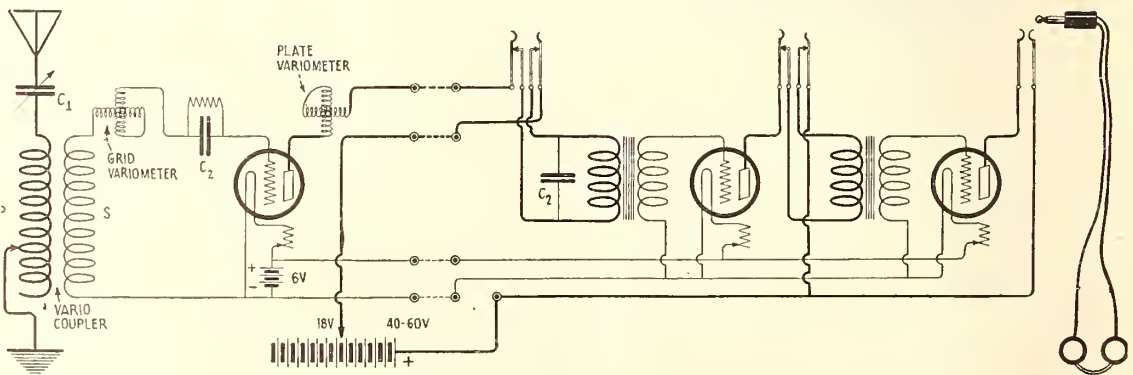
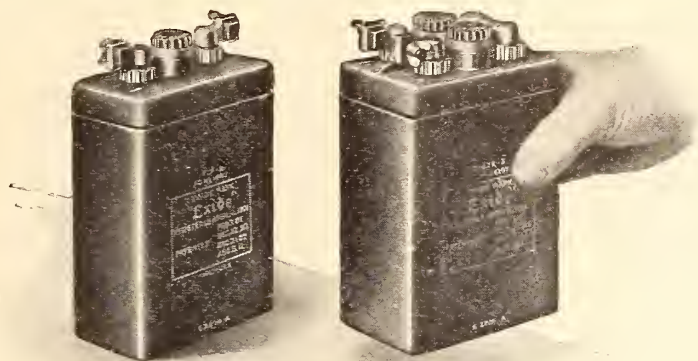

FIG. 3





## Midgets in size—but giants in power

**I**MAGINE a radio storage battery so light you can lift it on the palm of your hand, but powerful enough to supply all the current you need for long-distance receiving—and then some!

The new two- and four-volt Exide A Batteries for low-voltage tubes weigh only five and six pounds each. And they are wizards of efficiency—right in step with the latest developments in radio receiving.

These sturdy little batteries are neat and compact. They were specially designed for WD-11 and UV-199 vacuum tubes, but can be used with any low-voltage tube. The two-volt Exide A Battery consists of a single cell. It will heat the filament of a quarter-ampere tube for approximately 96 hours. The four-volt A Battery, having two cells, will light the filament of a 60-milliamper tube for 200 hours.



### For six-volt tubes

Like all Exide Storage Batteries, the Exide A Battery for six-volt tubes is dependable and long-lasting. It is made in four sizes, of 25, 50, 100 and 150 ampere hour capacities.

noiseless current. It permits the niceties of adjustment that make radio receiving an unalloyed

pleasure. The Exide A Battery for six-volt tubes has extra-heavy plates, assuring constant potential and uniform current over a long period of discharge. Like all Exide Batteries, it embodies the finest materials available.

### In marine and commercial wireless

On sea and on land the Exide plays an important role in the industrial life of the nation. In marine wireless, Exide Batteries provide an indispensable store of emergency current. A majority of all government and commercial wireless plants are equipped with Exides.

Exide Radio Batteries are sold by radio dealers and Exide Service Stations everywhere. Ask your dealer for booklets describing in detail the complete line of Exide Radio Batteries. Or write direct to us.



### Exide B Batteries

give noiseless, full-powered service over a long period of discharge. Designed throughout to prevent electrical leakage. Capacity, 3 ampere hours.

# Exide <sup>★</sup>

## RADIO BATTERIES

THE ELECTRIC STORAGE BATTERY COMPANY, PHILADELPHIA

*Oldest and largest manufacturers in the world of storage batteries for every purpose*

Service Stations Everywhere

Branches in Seventeen Cities

★ Tested and approved by RADIO BROADCAST ★

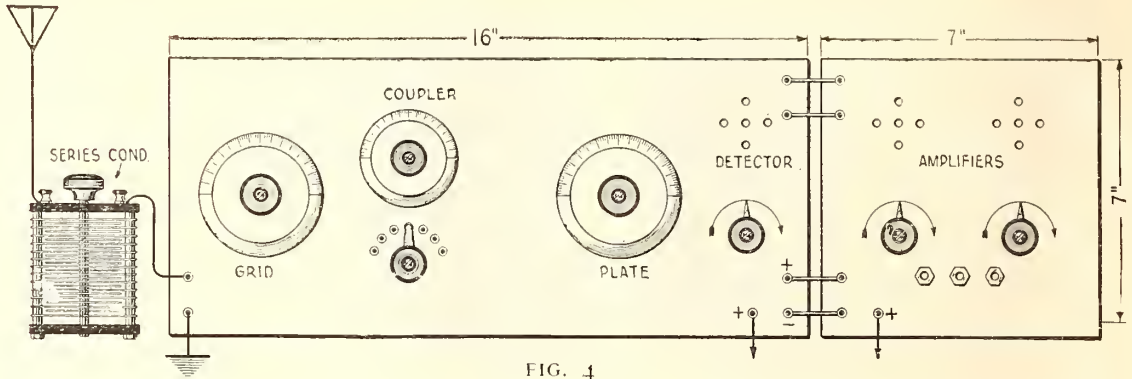

FIG. 4

## TROUBLE WITH A FOUR-STEP AUDIO AMPLIFIER

I have a four-stage audio-frequency amplifier, the results from which have not come up to my expectations. While amplification on the second and third stages is quite satisfactory, volume being consistent with the number of tubes, and the signals clear, there is apparently no further amplification on the last step, and the set howls unmercifully. Can you suggest any way in which this can be remedied?

L. B. L., TIGNAL, GA.

THE writer of the above encloses a diagram of his apparatus, showing a conventional receiver, the output of the detector being impressed on a straight four-stage amplifier. L. B. L. uses common A and B batteries, as well as what is, perhaps, too many C batteries.

The ordinary three-step amplifier is a precarious proposition, to say nothing of another additional stage. When such an amplifier is built in a single cabinet, there is almost certain to be a fatal amount of feed-back, due to the proximity of the transformers, wiring, etc., and the comparatively dense magnetic fields to which the strong plate currents in the higher steps give rise. In order to prevent howling, it is often necessary to add an unusually high C battery (the voltage applied under certain conditions to the grid) which generally causes the tube to be operated on an inefficient portion of its characteristic curve. This will tend to increase distortion, rather than reduce it, although it is for the purpose of reducing distortion that the C battery is used.

Our correspondent, and other readers contemplating similar amplifying apparatus, are strongly advised to break up the amplifier into two sections, in individual cabinets, the first containing two steps of amplification with ordinary amplifying tubes to which are applied plate voltages under one hundred volts. A C battery should be used in the second stage only when it is justified by an improved output. The second division should comprise the "power amplifier," consisting of special transformers (if the experimenter is able to secure them), power tubes (five-watt bulbs) and a separate B battery up to 350 volts. With such plate voltages, C batteries will be necessary, the voltage of which, varying with different tubes and plate potentials, must be determined by experiment. (The GRID does not advise the use of plate voltages in excess of 150 volts on other than special power-amplifying transformers.)

A four-step amplifier built in accordance with the foregoing general instructions should give as satisfactory results as may be expected from such a degree of intensification. However, The GRID does not consider the fourth stage of amplification justified either by results or ninety-nine

per cent. of volume requirements. An ordinary two-step amplifier will give more than sufficient volume for home entertainment, while a third stage of "power" amplification (a very efficient ready-made unit has been placed on the market) will further intensify the signals for re-broadcasting on sound waves from an open window or veranda.

Audio amplification is limited, particularly when the apparatus is constructed and operated by the average broadcast enthusiast, by distortion, and by the extraneous sounds which are often amplified more efficiently than the music, and which are generated in each additional stage.

## POLARITY

What is meant by the positive and negative poles of a battery?

E. J. L., LIBERTY HILLS, VA.

PLUS and minus, or positive and negative, are merely signs arbitrarily applied to the poles of a battery or to electricity in any of its many manifestations, in order to name a difference that *does exist*. In the pioneer days of electricity, when man's insight into the science was limited to the observance that when a piece of flint glass and a bit of cat's fur were rubbed together they tended to attract one another, it was discovered that the electrical world was divided into two dissimilar charges. For instance, though fur and glass adhered to each other after a brisk rubbing, it was found that a second piece of glass, similarly electrified, repelled the first piece of glass! Further experiments added to the puzzle by demonstrating that while two pieces of glass, electrified by friction with fur, repelled each other, the fragment of glass thus charged was attracted to a piece of glass electrified with cotton! In other words, it became apparent that there existed two kinds of electricity, which, for want of better words, were called positive and negative. For no particular reason, the piece of glass electrified by fur was held to have a negative charge, while that electrified by cotton a positive charge. A great number of experiments substantiated the theory of the like charges (plus and plus, minus and minus) repelling each other, and unlike charges (minus and plus which is the same as saying negative and positive) being mutually attractive.

The difference became more apparent and assumed a practical significance in the century that followed Franklin and Faraday. The two wires coming from a cell were found to be characterized by these same different charges, and a battery would build up an accumulative potential only when the individual cells were connected positive to negative. Dynamos were found to possess similarly different poles, and a relation was established between



**Radiotron  
WD-12**  
The standard  
base dry cell tube  
\$6.50

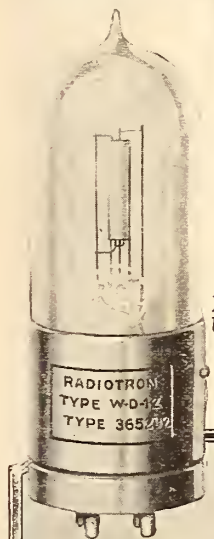

**Radiotron  
UV-201-A**  
The super-  
amplifier  
tube \$6.50



**Radiotron  
UV-199**  
The little tube of  
big performance  
\$6.50



**Radiotron  
UV-200**  
The long  
distance  
detector  
\$5.00

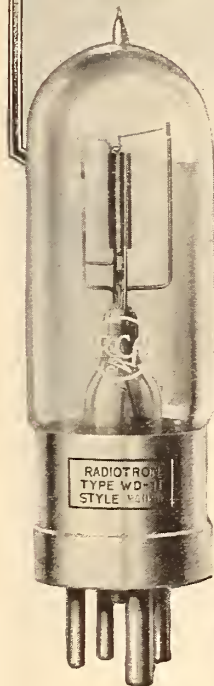

**Radiotron  
WD-11**  
The ideal  
dry battery  
detector \$6.50

**3,600,000  
Radiotrons/  
already made and sold!**

This one fact reveals at a glance the growth of radio! 3,600,000 RADIOTRONS already sold! It was the perfection of the RADIOTRON that made popularization of radio possible—and every vacuum tube set needs RADIOTRONS for clear reception and amplification—for sensitivity—and long distance reception.

RADIOTRONS were developed in the world's largest radio laboratories, where hundreds of modern radio achievements had their beginnings. There, they have been steadily perfected to give ever greater service. And now RADIOTRONS have been developed to meet new needs of both transmission and reception. When you ask for a RADIOTRON, take a good look to be sure the name is on it—and the trade mark!

This symbol  
of quality  
is your pro-  
tection



**Radio Corporation of America**

Sales Dept., Suite 2066: 233 Broadway, New York

District Sales Offices:

10 South LaSalle Street, Chicago, Ill.

433 California Street, San Francisco, Cal.

**Radiotrons**

REG. U. S. PAT. OFF.

★ Tested and approved by RADIO BROADCAST ★

magnets and the polarity of wire carrying electric currents. Finally, with the advent of the electron theory of matter, the difference between positive and negative electricity assumed a new significance, and science to-day declares the universe to be built up of these unlike charges, which, arranged in different formations, are manifest as every-thing—gases, liquids, and solids!

In a less general field, it is believed that a current of electricity is nothing more than a flow of small negative charges, electrons, from negative to positive (away from the repelling charge to that which attracts), an action that is demonstrated conclusively in the vacuum tube; for, unless the pole called positive on the B battery is connected to the plate of the audion, no current will flow through the tube, and the set will be inoperative.

We only know that there *are two kinds* of electricity. We note the characteristics of each in their relation to each other and to neutral charges, and call them positive and negative.

#### AMPLIFYING PHONOGRAPH MUSIC

*Will you kindly publish a diagram showing how a two-stage amplifier and a loud-speaker may be connected to a phonograph? The idea is to amplify the phonograph music considerably, for lawn dances, etc.*

*Will any other apparatus other than radio be required?*

W. H. J., HILO, HAWAII.

**T**HE most simple way to achieve what our correspondent desires is to purchase reproducing and amplifying apparatus designed especially for this purpose. It is manufactured by two of the largest makers of loud-speakers, and has been in the market for several years. The

manufactured equipment consists of an especially designed microphone built into a phonograph tone-arm, and two steps of power amplification, the first transformer of which is wound to take the low-voltage input from the microphone.

However, a system almost equal to the manufactured article can be made up by the radio fan almost entirely of radio equipment. The necessary parts are as follows:

One 6- or 12-volt microphone with a battery of the corresponding voltage. The transmitter may be of the standard type, salvaged from a discarded telephone.

One telephone induction coil. This may be purchased new for thirty-five or fifty cents, or, like the microphone, it may be removed from a defunct Bell instrument.

Two sockets, rheostats, and amplifying tubes.

One amplifying transformer for the second step.

Sixty to ninety volts of B battery.

Loud-speaker.

One A battery, which may also be used to supply the microphone current.

The circuit is shown in Fig. 3, and it will be observed that, excepting that the telephone induction coil substitutes for the usual first-step amplifying transformer, the bulb system is the standard amplifying arrangement.

The microphone should be placed where it will pick up the sounds emanating from the phonograph, and it is most conveniently fitted far back in the throat of the horn. A more ingenious and satisfactory method, which was used by The GRID for the radio transmission of phonograph music, is to build up an auxiliary tone arm with the microphone at the far end. The opening should so duplicate the standard tone arm that the reproducer may be fitted over it when it is desired to amplify the records.

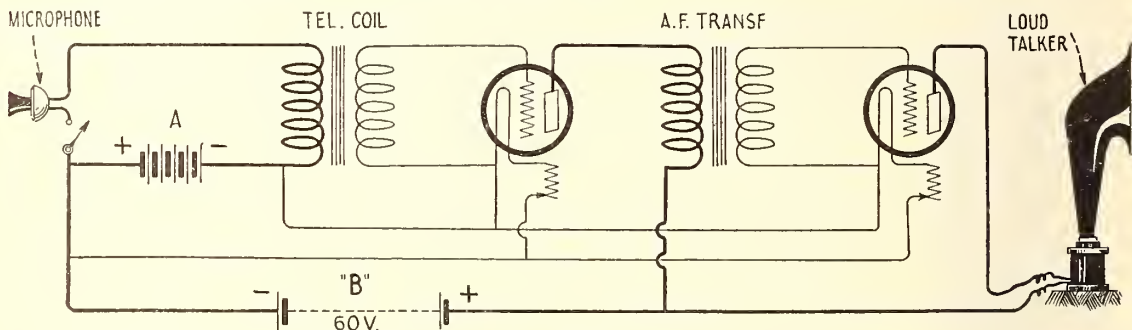

FIG. 5

### NEXT MONTH

*For months we have been looking for the ideal single tube receiver. In a single evening IN AUGUST, using a WD-12, we heard two stations in Chicago, one in Pittsburg, one in Boston, and many nearer our testing station on Long Island. Photographs, diagrams, and complete instructions next month.*

### What Would You Like to Have in Radio Broadcast?

*The editors would be pleased to hear from readers of the magazine on the following (or other) topics:*

1. *The kind of article, or diagram, or explanation, or improvement you would like to see in RADIO BROADCAST.*
2. *What has interested you most, and what least, in the numbers you have read so far.*



# The Receiver of Tomorrow



## The Symphony ★

Tomorrow in Radio means a wider and more useful as well as more entertaining broadcasting. Therefore, to the purchasers of receiving sets, the design, the material, the workmanship, the circuit and the assembly, all play an important part in the quality of reception, and distance heard.

The placing of a Symphony in your home is a permanent investment that will win your instant approval, and occupy a prominent place among your most cherished possessions.

The clear reception and unusual volume are the results of the high grade units, the fine workmanship, the most

efficient circuit, and the correct assembly. The improved circuit used in the Symphony combined with the accuracy of its construction, has increased the selectivity to a marked degree.

The range of the Symphony Receiver is unlimited. Recently, in Chicago, Havana, Cuba, was tuned in not only on a head set but heard plainly on a loud speaker.

The Symphony Receivers are made in two types—Three and Two stages of audio frequency amplification.

If your dealer cannot furnish information on the Symphony, write for illustrated catalog, giving us his name.

### JONES RADIO COMPANY

Lytton Building, Chicago

The Symphony is manufactured under the U. S. Patent No. 1113149, Armstrong Regenerative Circuit

*All parts used in the Symphony are built and guaranteed by the Kellogg Switchboard & Supply Company for twenty-five years manufacturers of complete telephone equipment*



## The Loud-Speaker With the Natural Tone

The Bristol "Audiophone" will bring into your presence the actual "tonal personality" of the speaker, the singer or the player. You will hear them as they are—not disguised by mechanical distortion. The "Audiophone" is a true sound reproducer, retaining all the fine gradations of tone quality, volume and feeling which distinguish the original performance of the artist. You forget the instrument, in your enjoyment of the entertainment it brings to all your household and the guests who may join you.

BRISTOL   
TRADE MARK  
**AUDIOPHONE**  
PATENTS PENDING, DESIGN PATENTS PENDING  
**LOUD-SPEAKER**

Years of research in sound reproduction, in the laboratories of an established engineering concern, have made the "Audiophone" what it is—have given it its round, full tone, its ample carrying power, its distinctive freedom from blurring and distortion. It needs no separate storage battery for magnetizing current, and can be used with any two or three stage power amplifiers.

"AUDIOPHONE SR." Complete, 15-inch bell \$32.50  
"AUDIOPHONE JR." Complete, 13-inch bell \$22.50

A new Bristol single stage power amplifier for use with the usual two stage amplifier can be furnished, which will greatly increase the range of the Audiophone where desirable. Price \$25.00

*Ask your dealer to demonstrate the "Audiophone". If he hasn't it, write us—we will see that you are supplied.*



**THE BRISTOL COMPANY**  
WATERBURY, CONNECTICUT

★ Tested and approved by RADIO BROADCAST ★



# Burgess, the *Radio* Battery

*Specified by radio engineers — designed and built by wireless specialists—and recommended by leading manufacturers of radio equipment.*

Burgess Radio Batteries, the result of years of careful experiments are built under exacting manufacturing standards which must meet the requirements of strict laboratory formulae and tests — a supervision that insures their perfect operation.

For professional or amateur radio use, where noiselessness, long life, high capacity and uninterrupted, dependable service are essential, Burgess has no superior.

Burgess Batteries are built for both "A" and "B" circuits. The Burgess No. 6 is used and found most satisfactory on the "A" or filament circuits equipped with the new type one and one-half volt vacuum tubes. The Burgess "B" Battery is everywhere recognized as the Standard of Quality in the wireless field.

**BURGESS BATTERY COMPANY**  
Engineers — Dry Batteries — Manufacturers  
FLASHLIGHT — RADIO — IGNITION — TELEPHONE

General Sales Office: Harris Trust Bldg., Chicago  
Laboratories and Works: Madison, Wisconsin

Branches:

New York Boston Washington St. Paul Kansas City New Orleans

In Canada: BURGESS BATTERIES, Ltd.  
Winnipeg, Toronto, Montreal



# BURGESS RADIO BATTERIES

"ASK ANY RADIO ENGINEER"



★ Tested and approved by RADIO BROADCAST ★

# Dependable Radio Sets *and* Service

Can always be had from local dealers  
who have been honored with the

## M. R. C. FRANCHISE

For Three Reasons:

- 1: Franchise is granted only to merchants of standing and financial responsibility, with sufficient technical experience to render intelligent service.
- 2: "Michigan" Radio Sets are the finest examples of correct Regenerative radio engineering, expressed in superlatively good workmanship.
- 3: The Michigan Guarantee is as valid as a Bond. For back of it stands the strongest independent Radio manufacturing concern in the United States.

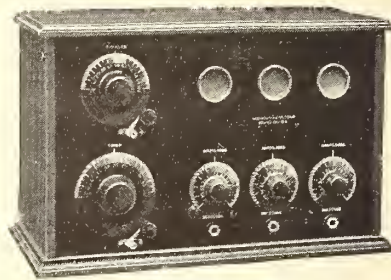

"SENIOR" SET

## M. R. C. Regenerative Receiving Sets



are built under Armstrong License (U. S. Pat. 1,113,149 and letters patent No. 607,388). This means that they embody the latest development in Regeneration—the soul of radio.

### Long Distance Wonder Workers

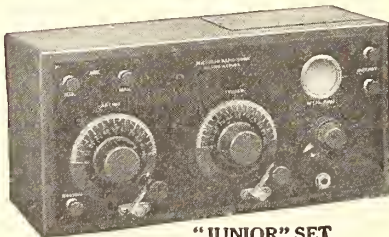

"JUNIOR" SET

The "Senior Set" includes both detector and amplification, and can be used with either headphones or loud speakers or both.

The "Junior Set", a detector unit only, is limited to headphone reception. It can however, be hooked up with the Michigan Amplifier unit for loudspeaker reception.

Send for the M. R. C. Circular, giving full information on both sets and parts, and telling of some of the long-distance triumphs of M. R. C. set owners.

## MICHIGAN RADIO CORPORATION

GRAND RAPIDS, MICHIGAN



**General Radio Type 300 Amplifier Unit—**

*Works equally well with crystal or tube detectors. Is a compact unit, wired ready for external connections. Two or more units may be used together to obtain multi-stage amplification.*

**Prices**

Type 300-A Amplifier Unit for WD-11 Tubes, complete except for tube and batteries, **\$7.50**

Type 300-B Amplifier Unit, for standard 6 Volt Tubes, **\$8.00**

**Type 231-A Transformer**—Gives the maximum amplification possible without distortion. Like all Amplifying Transformers manufactured by The General Radio Company, the Type 231-A is guaranteed.

Price **\$5.00**

**General Radio Type 214 Rheostat—**

A convenient, practical instrument, equally well adapted for experimental service or permanent installations. You'll never cause unpleasant noises in the phones when you rotate the contact arm of a Type 214 Rheostat.

**Price**

For the new UV201-A Tubes, 20 Ohms.

For the newer UV199 Tubes, 50 Ohms.

For the Standard Tube, 7 Ohms.

**\$2.25**

**Type 214 Potentiometer—**

To get your gas detector on that sensitive kink by fine adjustment of the plate potential, use this General Radio 400 Ohm Potentiometer. It will control regeneration in your radio frequency amplifier by a positive grid bias.

Price **\$3.00**

**Amateurs—**

Bring your problems to us. Our Engineering Staff is always at your disposal.



For more than eight years, among men who know and use Radio Apparatus of the better sort, the name—General Radio Company—has been accepted as a guarantee of all that goes to make up satisfaction and as synonymous with the advances in theory and practice which accompany all true Radio progress.

As an example—for the amateur who wants real Radio efficiency—there is no single piece of apparatus which more completely fills its niche than the General Radio Type 300-A Amplifying Unit—the Amplifying Unit which requires no storage battery.

If you are interested in Radio Apparatus in which price is subordinated to satisfaction, send for Bulletin 914B. It is an educational pamphlet for the amateur who wants better equipment.

**GENERAL RADIO CO.**

*Manufacturers of*

**Radio and Electrical Laboratory Apparatus  
11 Windsor Street**

**Cambridge, Mass.**

5169





**A high quality 1000-meter tuning coil for \$3.00**

**H**ERE'S as fine a tuning coil as you ever saw at a price that insures tremendous value. Made in such large quantities that price is no index of its quality. Mahogany-finished hardwood ends, nickel-plated metal parts, silk-covered wire on seamless tube. Double slides insure clear, sharp tuning. Order one from your dealer.

**FROST-RADIO**

The complete Frost Radio line of Frost Fones, Plugs, Jacks, Jac-Box, Microphones, Tuning Coils, Receiving Transformers, Extension Cords, offers radio users the highest quality apparatus at quantity-production prices. Another example of Frost Radio value is the No. 400 Receiving Transformer shown here. Mahogany-finished hardwood base and ends; polished nickel-plated metal parts. 200 to 4000 meter range. Silk-covered wire wound. See it at your dealer's. Retail price: \$8.50.

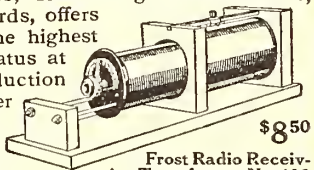

Frost Radio Receiving Transformer No. 400 \$8.50

The dealer who sells Frost Radio is a good man to know. He guarantees Frost merchandise because he knows it is right. See him today.



The same fine quality which has made Frost Fones the world's fastest-selling headset is back of every Frost piece of Radio apparatus.

"Like Postage-Stamps

Used Everywhere"

**HERBERT H. FROST, Inc.**  
154 WEST LAKE STREET, CHICAGO, ILLINOIS.



**Recharge Your Battery at Home**

Charges Both A and B Radio Batteries

Don't be without the use of your Radio Receiving Set while your battery is being charged. Get a Valley Charger and charge your battery right at home. Attach the Charger to your home lamp socket—attach the clips to the battery terminals and you will get a quick, tapering charge which just exactly charges your battery, but cannot over-charge or harm it in any way.

Will charge the A 8 volt battery at a 5 ampere rate, and the B 22½ volt battery at the required ½ ampere rate. 45 volt B batteries may be connected in parallel so that they can also be charged. **SAISFACTION GUARANTEED** If your local distributor cannot supply you, write direct to

**VALLEY ELECTRIC COMPANY,**  
Department G ST. LOUIS, MO.

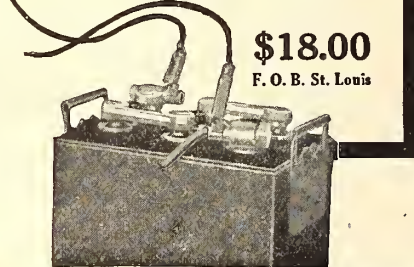

**\$18.00**  
F. O. B. St. Louis

**FREE Radio Catalog**

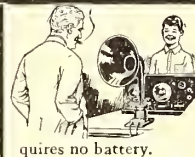

Our big stock of standard makes of radio sets, parts and supplies, fully illustrated. Play safe—buy standard equipment from a reliable house. We ship from stock. Send \$5.00 for Murdock Loud Speaker, including fibre horn, stand and adjustable phone unit. Requires no battery.

**Julius Andrae & Sons Co.**  
In Business Since 1860  
112 Michigan St. Milwaukee, Wis.

**Weston Filament Voltmeter**

Makes it possible to prevent premature tube burn-outs—facilitates exact tuning—duplicates results instantly.

Write for Circular J



**Weston Electric Instrument Co.**  
179 Weston Avenue NEWARK, N. J.



# Try the Bradleystat on Your Radio Set, to-night

## *A New Thrill Awaits You!*

*Pull in those distant stations that you lose with Wire Rheostats*

Does your receiving range enable you to pick up concerts over great distances? If not, try the Bradleystat.

Read this interesting letter from Chas. H. M. White of Massachusetts Institute of Technology at Cambridge, Massachusetts:

*"I have tried the Bradleystat on my radio set. The improvement is really remarkable and beyond all my expectations. Previously I only picked up local stations and WJZ, but on my first trial with the Bradleystat I heard KYW (Chicago), WOC (Davenport) and many other stations."*

Get the Bradleystat, today, from your nearest radio dealer and get more enjoyment from your radio set. Insist on the genuine Bradleystat.

**Allen-Bradley Co.**  
Electric Controlling Apparatus

278 Greenfield Avenue • Milwaukee, Wisconsin  
Member of the National Radio Chamber of Commerce

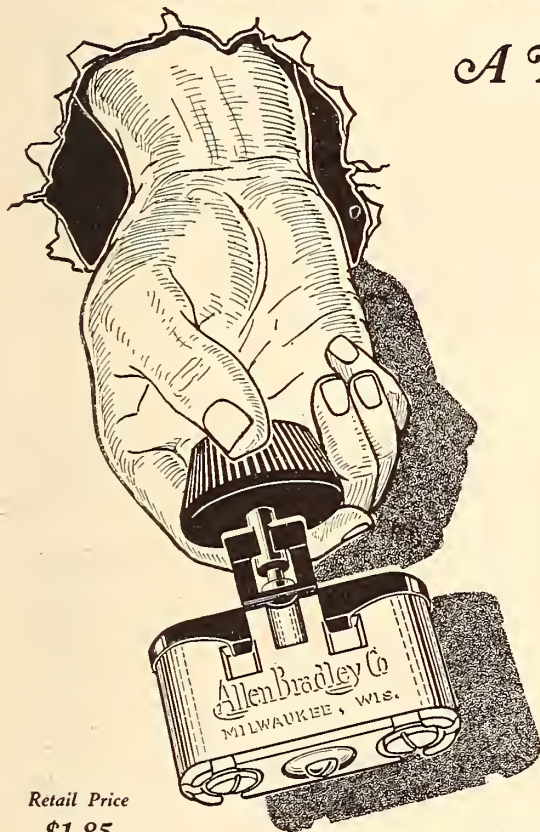

Retail Price

**\$1.85**

P.P. 10c extra

### Other Radio Products

The Bradleyometer, a perfect potentiometer and the Bradley-adaptor for the WD-11 tubes are two new radio products equal in quality to the Bradleystat.

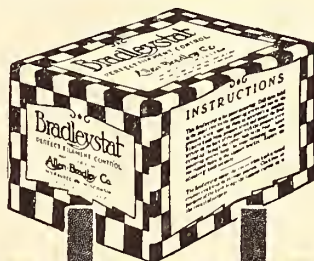

# ★ Bradleystat

REGISTERED U.S. PAT. OFF.

## PERFECT FILAMENT CONTROL

★ Tested and approved by RADIO BROADCAST ★





## Steady, Full-powered Batteries

EVERY radio set has its own peculiarities—little niceties of adjustment at which best results are obtained. Battery voltage and amperage must be just so. And once adjusted, current must have sustained evenness and steadiness.

Get *good* batteries. They're the most satisfactory and economical in the end. Westinghouse Radio Storage Batteries will settle the problem practically for good. They last indefinitely and are easily and repeatedly rechargeable. Built by Westinghouse—you know they're *RIGHT*.



At radio dealers and Westinghouse Battery Service Stations everywhere. Write for illustrated folder, "Westinghouse Radio Storage Batteries."

WESTINGHOUSE UNION BATTERY CO.  
Swissvale, Pa.

# WESTINGHOUSE

RADIO  
"A" "B" and "C"  
BATTERIES

Westinghouse "A" Batteries are carefully constructed, full-capacity, slow-discharge, long-life batteries. Made in 4, 6, and 8-volt sizes with 5, 9, and 13 plates per cell, to meet the various filament-battery requirements.

Westinghouse "B" Batteries. The Westinghouse 22-M G-2 (22 volts) is a marvel for steady, noiseless, full-powered service. Glass case; visible interior; sealed-in tops. Larger types, too; also 2-volt single cells for "C" batteries.

**NOVO** ★  
**"B" BATTERIES**

NOISELESS DEPENDABLE

NOTE THE INSULATED BINDING POSTS AND 7/16 IN. WIRE CONNECTOR

**NOVO MFG. CO.**  
424 W. 33<sup>rd</sup> ST. NEW YORK 531 SO. DEARBORN ST. CHICAGO

**Super-Sensitiveness!**

THE crystal is the "bull's-eye" of your crystal receiving set. Unless it is super-sensitive you are wasting time and entertainment and cannot "hit" the combination for best results. Insist upon the genuine original Arlington Tested NAA Detector Minerals. They are carefully selected from bulk stock, individually tested and guaranteed super-sensitive.

Galena, Silicon or Goldite price per crystal, 25c. Same mounted in brass cup, 40c. Obtainable at your dealer's or sent direct (post-paid) on receipt of price.

**The Newman-Stern Co.**  
Newman-Stern Building Cleveland

RADIO "A" & "B" STORAGE Batteries CHARGED at Home For a Few Cents Overnight with "The PATENTED FULL WAVE" 100-130 Volts 60 Cycle A. C. Magnetic Taper Charge Design

All Types But "B"  
Charge  
AUTO  
Batteries  
Overnight  
Right in  
Your CAR

**\$15**

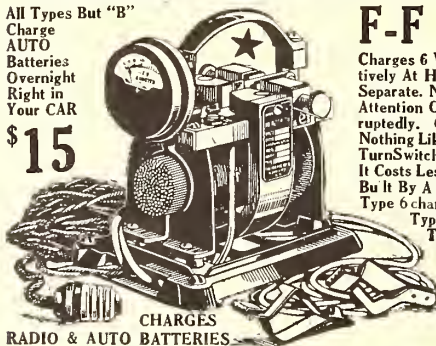

CHARGES  
RADIO & AUTO BATTERIES

## F-F RADIO RECTIFIER

Eventually You Will Buy An F-F RECTIFIER. Why Not Now? The Sooner You Buy It; The More You Save. A-B Charges 6 Volt "A" & Auto; & up to 120 Volts Of "B" & Loud Speaker Storage Batteries In Series Inductively At Home Overnight; Disconnecting & Multiple Connections Unnecessary. Charging Circuits Separate. No Chance For Grounds Or Short Circuits. Nothing To Slop Over, Be Filled, Burn Out, Need Attention Or Cause Trouble. Infusible Rectifying Brushes Maintain Constant Efficiency Uninterruptedly. Complete Portable Automatic. No Skill Required. AMMETER Eliminates Guess Work. Nothing Like It Made. Lasts Lifetime. Screw Plug In Lamp Socket; Snap CLIPSON Battery Terminals; Turn Switch & Batteries Charged In Morning. Charged Batteries Mean Fewer Expensive Replacements. It Costs Less To Buy An F-F RECTIFIER than To Be Without One. INSIST ON THE F-F RECTIFIER Bu It By A Master Of The Art in 7 TYPES. Thousands Sold Make Possible These POPULAR PRICES.

Type 6 charges "A" 6 Volt Battery At 6 amperes \$15 Type 12 charges 12 Volt Battery At 5 amperes \$15  
Type B charges Radio "B" Batteries Up to 120 Volts \$15 Type A-B is Combination Of Types 6 & B \$20  
Type 166 charges 6 Volt Battery At 12 amps \$20 Type 1612 charges 12 Volt Battery At 7 amps \$20  
Type 1626 is a Combination of Types 166 & 1612 and Charges Both 6 & 12 Volt Batteries \$28  
The 3 Lower Types are recommended for heavy Batteries, or where time is limited. SHIPPING WEIGHTS Complete with AMMETER & BATTERY CLIPS 11 to 15 lbs. Purchase from DEALER, or Mail Check for Prompt Shipment. Include Postage and Insurance Charges for P. P. Shipment, or Write us to Ship Type desired C. O. D. Order Now, or WRITE Immediately for FREE Descriptive BOOSTER Bulletins 41 & 41A.

**FRANCE MFG. CO., CLEVELAND, OHIO, U. S. A.**

★ Tested and approved by RADIO BROADCAST ★



# CROSLEY *Model X*

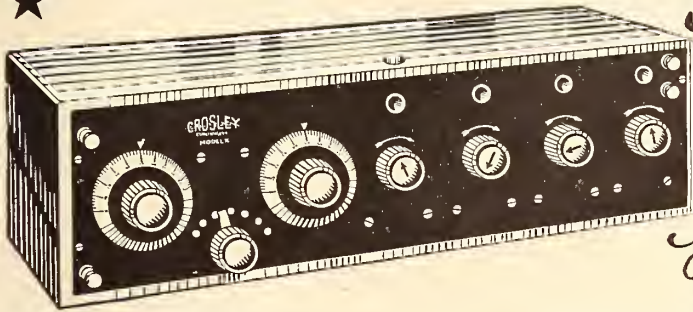

# \$ 55

*A 4 tube  
Radio*

THE HIT OF THE RADIO WORLD

For Sale by Good Dealers Everywhere

*Free Catalogue on request to Dealer or Consumer*

*Frequency Set*

## CROSLEY MANUFACTURING COMPANY

520 ALFRED ST.

CINCINNATI, OHIO

# CROSLEY *Model Vc*

# \$ 20

*Regenerative Receiver Set*

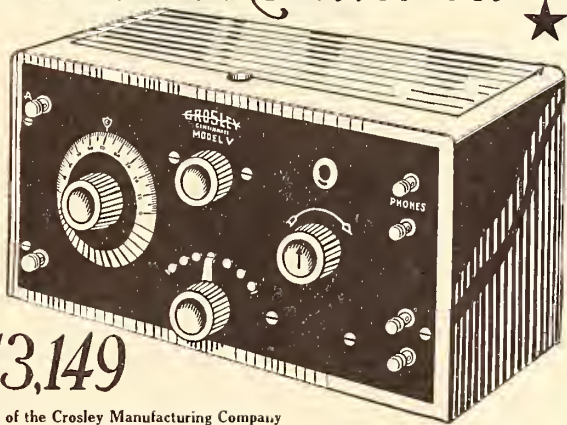

*Licensed  
under Armstrong  
U.S. Patent No. 1,113,149*

The trade name "Crosley" is used by permission of the Crosley Manufacturing Company

*Write for Free Catalogue*

## THE PRECISION EQUIPMENT CO.

*Powel Crosley Jr. President*

520 GILBERT AVE.

CINCINNATI, OHIO

★ Tested and approved by RADIO BROADCAST ★



## Holtzer-Cabot No. 2 Universal

### The Latest Achievement in Radio Head Sets

After exhaustive experiments and actual manufacturing experiences we have produced a receiver which, for tone quality, has no equal.

It is tested, not by "listening-in," but by a specially designed scientific instrument which gives its true tone quality by actual sound measurement.

Our new head bands are covered with flexible rubber, making them comfortable and sanitary.

Weight, only twelve ounces

Price \$12.00.

*The Holtzer-Cabot Electric Co.*  
Boston and Chicago



# CHELSEA



**PRICE \$40.00**

## REGENERATIVE RECEIVER ★

A REAL BROADCAST RECEIVER

Licensed Under Armstrong U. S. Patent No. 1113149.  
For amateur use only.

Write for Catalogue No. 7 of New Chelsea Radio Equipment.

**CHELSEA RADIO CO.**  
152 5th St., Chelsea, Mass.

*Determines*  
RANGE  
OF  
YOUR SET

**\$1**  
Complete



*Determines*  
DISTANCE OF  
CALLS  
RECEIVED

**\$1**  
Complete

## The McNeary Radio Scalometer

*and Official Radio Map*

After you recover from the thrill you get every time you tune in on an out-of-town station, the first thing you want to know is HOW FAR was that?

With the Scalometer mounted on the official map you read the distance directly on the tape—instantly and correctly.

<p><b>SCALOMETER</b> An instrument of precision in a beautifully finished aluminum case.</p>	<p><b>RADIO MAP</b> Authoritative, up-to-the-minute, showing broadcasting stations, time zones, radio districts, cities and towns of the United States and Canada.</p>	<p><b>BROADCAST DIRECTORY</b> In handy booklet form with all broadcasting stations alphabetically arranged by call letters.</p>
--	--	---

*If your dealer cannot supply you, send one dollar to*

**EMBLEM MANUFACTURING CORPORATION**  
253 Middle City Bldg., Philadelphia, Pa.





# Federal

Is A Large User

# Of Formica

THE Federal Telephone and Telegraph Company of Buffalo is a large factor in the radio industry and has an excellent reputation for the quality of its product.

It is a very extensive user of Formica insulation not only in the complete sets which it produces but in the radio parts, variometers, variocouplers, head sets of which it is a large manufacturer.

A list of the users of Formica reads like a directory of the leading independent radio manufacturers. So many of the best informed radio men in America cannot be mistaken in their opinion that Formica is most uniform, the best looking, and the most efficient radio insulation.

*Dealers and amateurs can safely follow these great concerns in selling or using Formica.*

## THE FORMICA INSULATION COMPANY

4628 Spring Grove Avenue  
Cincinnati, O.

### SALES OFFICES

50 Church St., New York, N. Y.  
422 First Ave., Pittsburg, Pa.  
1042 Granite Bldg., Rochester, N. Y.  
415 Ohio Bldg., Toledo, Ohio

1210 Arch St., Philadelphia, Pa.  
1819 Lyndale Ave., S. Minneapolis, Minn.  
Sheldon Bldg., San Francisco, Calif.  
Whitney Central Bldg., New Orleans

414 Finance Bldg., Cleveland, Ohio  
9 S. Clinton St., Chicago, Ill.  
313 Title Bldg., Baltimore, Md.  
47 King St., Toronto, Ontario

# FORMICA

Made from Anhydrous Redmanol Resins  
SHEETS TUBES RODS

★ Tested and approved by RADIO BROADCAST ★



THE SYMBOL OF SERVICE

# CONTINENTAL

*"New York's Leading Radio House"*

## TRANSFORMERS

**Model UV-712 and Model UV-1714**  
*"Audio Frequency" "Radio Frequency"*

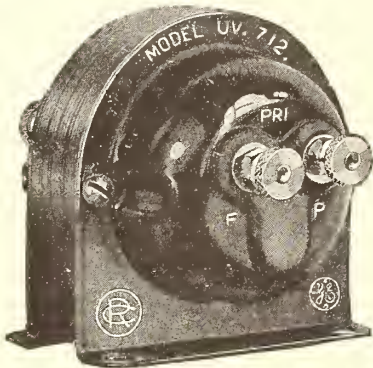

Model UV-712 and UV-1714 two transformers designed especially by the Radio Corporation for their detector tubes UV-200 and UV-201.

Important features--Ranges may be doubled or tripled.

Distortion greatly reduced.

Selectivity greatly increased.

Vacuum tube noises practically eliminated.

Further information on request.

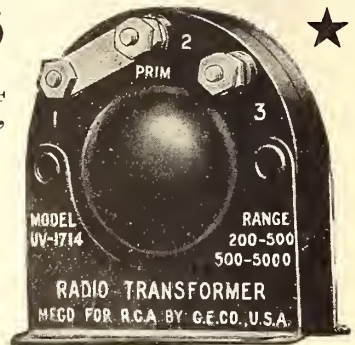

*"Modern Radio"*—a two hundred and eight page catalogue of our Radio supplies, equipment and apparatus sent for twenty-five cents.

2031-Q

**CONTINENTAL RADIO AND ELECTRIC CORPN.**

6 AND 15 WARREN ST. - - - - NEW YORK, U. S. A.



### Spilled Milk

and burned out bulbs are much alike. The time to attend to them is before they happen. Care is the best safeguard for the milk; and the

### RADECO SAFETY FUSE

(Patent Pending)

is the only absolute and positive means of protecting the tube.

The RADECO Safety Fuse fits directly on the filament terminals where no excess current, even an accidental short from faulty wiring can possibly get by. It fits any standard tube used in any standard socket and does not affect the efficiency of your set.

4 in standard package \$1.00

For WD11, 50 cents For WD12, 50 cents

For 201A, 50 cents

For other tubes, 4 for \$1.00

*Different tubes require different capacity fuses. State what tube fuses are for.*

**Radio Equipment Co.**  
 630 Washington St. Boston, Mass.  
*New England's Oldest Exclusive Radio House*

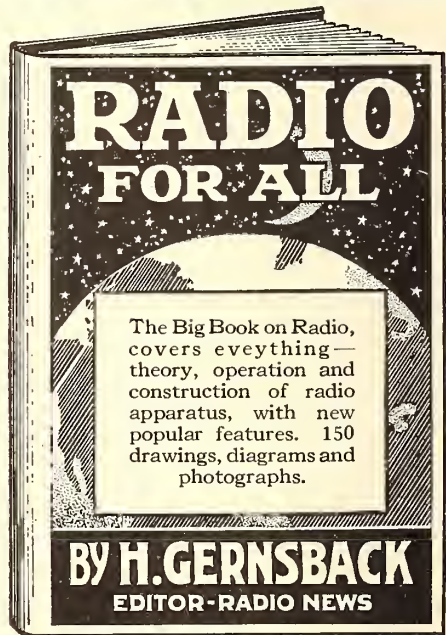

The Big Book on Radio, covers everything— theory, operation and construction of radio apparatus, with new popular features. 150 drawings, diagrams and photographs.

**BY H. GERNSBACK**  
 EDITOR-RADIO NEWS

*At all Bookstores, \$2.00*

or postpaid for \$2.10. Write for circular B.

**J. B. LIPPINCOTT CO.**

226 S. Sixth Street

Philadelphia, Pa.





# Soprano Solos by The Stock Exchange

When you try to tune in with a single circuit receiver, it is not surprising that songs should suddenly turn into market quotations and bedtime stories into weather reports.

For with several hundred powerful broadcasting stations all operating on one narrow wave band, it takes real selectivity and sensitivity to get a satisfactory radio programme.

Get a Paragon three-circuit receiver. Then you will have the pleasure and satisfaction of obtaining the station you want when you want it. Clear, complete programmes without interruption or disturbance.

Ask some experienced amateur what he knows about

# PARAGON

Reg. U. S. Pat. Off.

## RADIO PRODUCTS ★

The amateur will tell you that the Paragon three-circuit receiver, because of its great superior selectivity and sensitivity, can pick and choose between broadcasting stations of about the same signal strength with less than one per cent differential.

This means that with a Paragon receiver you get what you want when you want it—complete messages and clear music from the station you tune in on, without interruption and jamming. Until you have listened in with a Paragon three-circuit receiver, you cannot guess the real pleasure and fascination of radio.

Long before broadcasting popularized radio with the general public, Paragon equipment was the choice of the experienced amateur. He will tell you today that if you want quality and satisfaction, Paragon Radio Products are the best and safest buy on the market.

*An illustrated Catalog of Paragon Radio Products Is Yours For the Asking*

DEALERS—The Adams-Morgan Company has an interesting proposition to make to reputable radio dealers who believe in quality merchandise. Details on request.

ADAMS-MORGAN COMPANY  
10 Alvin Ave., Upper Montclair, N. J.

Type RD-5 Regenerative Receiver and Detector—\$75.00  
Type A-2 Two-Stage Amplifier—\$50.00  
(Licensed under Armstrong Patents.)

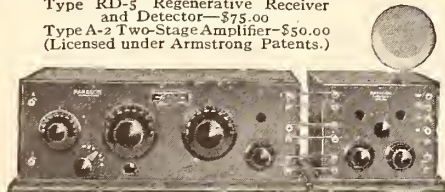

### Also Manufacturers of PARAGON

Radio Telephone Transmitters	Amplifier Transformers
V. T. Control Units	Control Dials
Rheostats	Amplifiers
Potentiometers	Receivers
V. T. Sockets	Switches
Detectors	Variometers

★ Tested and approved by RADIO BROADCAST ★



# ★ Thrills!!!

Thrills never end when you have a Tuska Popular—the regenerative receiving set that experts recommend. Signals clear and sharp come in night after night from far-away stations. And for nearby programs, plenty of volume without distortion. Every part Tuska-made; known for 12 years as fine radio instruments.

**The C. D. TUSKA Co.**  
Hartford, Conn.

### Tuska Popular No. 225

Regenerative Receiving Set, Tuska receiver, detector and 2-stage amplifier, licensed under Armstrong U. S. Patent No. 1,113,149. Catalogue No. 13-A, showing Popular and other sets, on request.

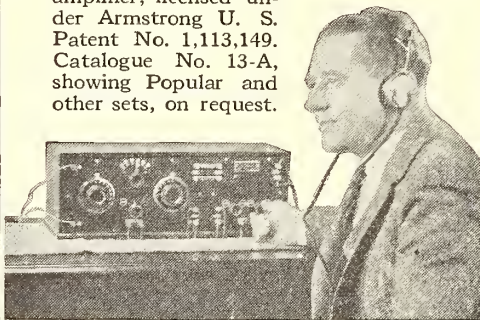

## TUSKA RADIO



### And Feel the Difference, Too!

**Y**OUR RADIO fan wears his head set several hours at a time. He probably bought it because the dealer let him "listen to the difference," and he very quickly learned the character of the true musical tone C I C gave him, because of its non-metallic diaphragm. He learned something more, however, after several hours' use. The big, comfortable caps covering the entire ear—the broad, well fitting aluminum band—they soon showed him that C I C not only means beauty of tone. It means also "Solid Comfort." Point this out to your trade, too!

**CONNECTICUT INSTRUMENT CO.**  
Stamford Connecticut

## FREE HAND BOOK OF RADIO HOOKUPS

We will send you free a useful Hand book containing 25 easily understood diagrams of tested radio hookups. Just enclose 2c. stamp for postage.

We will appreciate it as a favor if you will mention the name and address of the radio dealer with whom you prefer to trade, and whether he now carries All-American Audio- and Radio Amplifying Transformers.



**RAULAND MFG. CO.**  
200 No. Jefferson St. Chicago, Ill.



## LEARN RADIO

Here's your opportunity. Radio needs you. Win success in this fascinating field. Trained men in demand at highest salaries. Learn at home, in your spare time.

### Be a Radio Expert

I will train you, quickly and easily, to design, construct, install operate, repair, maintain and sell all forms of Radio apparatus. My new methods are the most successful in existence. Learn to earn.

**\$1,800 to \$10,000 a Year**

**FREE** Wonderful home-construction, tube receiving set, of latest design. Write for "Radio Facts" free. Engineer Mohaupt.

**American Electrical Association**  
Dept. Bc 4513 Ravenswood Ave., Chicago



# MURDOCK

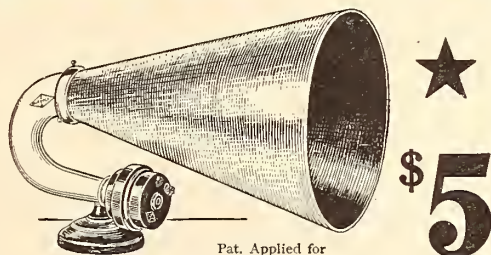

*for the new*  
**MURDOCK  
LOUDSPEAKER**

Never before have you been able to get so good a Loudspeaker for such a low price.

Complete with our new Loudspeaker phone unit, fibre horn, aluminum tone chamber and molded base.

You do not need extra batteries to use the Murdock Loudspeaker. It works splendidly with amplification. Do not use on a crystal set.

For 18 years Murdock Headphones have been leaders in their field. Huge production has made it possible to sell this quality product at a low price—2000 ohms \$5.00; 3000 ohms \$5.50.

Now the new Murdock Loudspeaker is becoming a real sensation in the Radio field—another quality product at an unheard of price.

Get one of these new Loudspeakers from your dealer. Be sure it's a Murdock.

If your dealer cannot supply you with either Murdock Headphones or a Murdock Loudspeaker, send your order and dealer's name direct to us.

## WM. J. MURDOCK COMPANY

*General Offices and Factory*

341 Washington Avenue, Chelsea, Mass.

*(Sales offices)*

New York San Francisco Chicago  
Los Angeles Seattle

# RADIO

STANDARD APPARATUS SINCE 1904

# MIRACO GETS 'EM 1500 MILES AWAY

Users of the MIRACO Radio Frequency Broadcast Receiver report wonderful results. St. Louis hears Schenectady—Davenport hears Newark—Cincinnati hears San Francisco.

Reception is clear and distinct, tuning is very sharp, and there's practically no interference.

MIRACO sets may be used with either WD 11 tubes and 1½ volt dry cell or 6 volt tubes and 6 volt storage battery.

Order *your* MIRACO set TO-DAY and be sure to specify tubes to be used.



Retail Price \$54.50

## DEALERS

When you get our proposition in detail—you'll WANT TO PUSH THE MIRACO LINE.

## AGENTS

Wanted Everywhere.

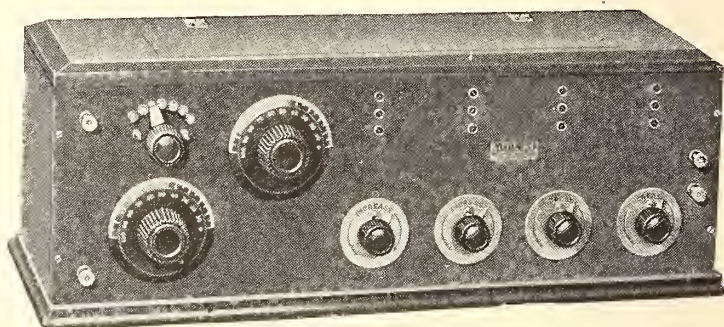

THE MIDWEST RADIO COMPANY

806 Main Street, Cincinnati, Ohio

# BRACH VACUUM RADIO PROTECTOR

★ ASK YOUR INSURANCE AGENT

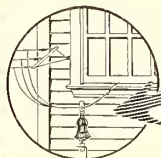

Approved by National Board Fire Underwriters

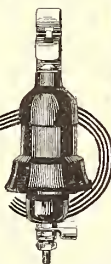

The Choice of the Foremost Engineers for over 17 Years \$3

# SOLDERALL

The Only Convenient Metal Solder  
Every Electrical Connection Needs SOLDERALL For Perfect Reception

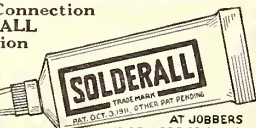

AT JOBBERS AND DEALERS OR BY MAIL 25¢ A TUBE  
L.S. BRACH MFG. CO. NEWARK, N. J.

**"BUILD YOUR OWN" With "RASCO" Parts!**  
If you need small radio parts in a rush, "RASCO" will supply them cheaper, better and quicker than any one. Be sure to get our great 68-page catalog. Over 500 different parts, 300 illustrations. This catalog contains 75 Vacuum Tube Hook-Ups, all values being shown. Due to great cost, catalog sent only upon receipt of 15c, stamps or coin.  
Radio Specialty Co., Inc.  
102 Park Place, New York

*Rasco*

# The FRENCH BINDERS

Good books with artistic binding

COUNTRY LIFE PRESS GARDEN CITY, N. Y.

**FREE** to Car Owners, Garagemen, Mechanics. Send TO-DAY for FREE COPY of the American Automobile Digest. Contains helpful, instructive information on overhauling, ignition, carburetors, storage batteries, wiring adjusting, repairing, etc. Profusely illustrated.

American Automobile Digest, 669 Butler Bldg., Cincinnati, O.



# CONNECTICUT RADIO

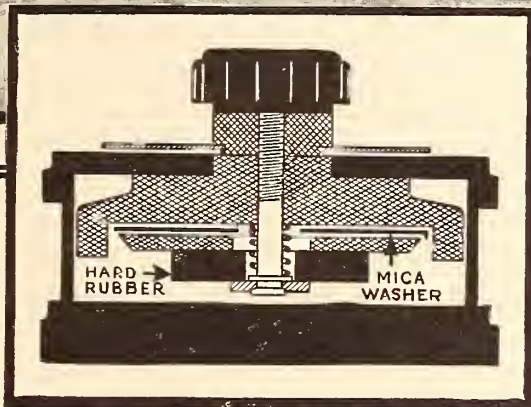

*Finer  
Adjustments  
Better  
Selectivity  
Greater Signal  
Strength*

*Simple as the  
Symbol that  
Stands for it*

## *The Secret of Its Efficiency*

It is a well-known fact that losses in radio condensers take place in the solid insulating material used in their construction.

And it is equally true that a condenser increases in efficiency of signal reproduction as its losses decrease.

The CONNECTICUT Variable Condenser not only employs the two best insulating materials known—mica and hard rubber—but the smallest possible amount of each. This, then, is the reason for its extremely low resistance—0.2 ohm—as well also the secret of its high efficiency at short wave lengths.

*Descriptive bulletin 100-E upon request*

Panel type, J-108, \$5.00

Portable type, J-107, \$6.00

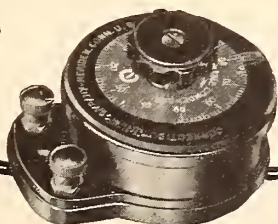

**CONNECTICUT**  
MERIDEN

**TELEPHONE  
& ELECTRIC**  
RADIO DIVISION

**COMPANY**  
CONNECTICUT





"These phones sure have a mellow tone"

## You Can Get BASCO Phones Despite Demand

**N**O NEED for accepting substitutes. Every possible measure is being taken by the manufacturers of BASCO Phones to keep up to the demand—and it's being done without slighting mechanical exactness. Close inspection guards BASCO Phone quality irrespective of demand. BASCO quality—keen sensitiveness—deep, natural-voice pitch—lightweight—head comfort—these features should direct your choice in selecting BASCO Phones for allround satisfaction.

See BASCO Phones and other units of the complete BASCO Radio Line. If your dealer can't supply you, write us direct.

**\$6.00** 2000 Ohms      3000 Ohms **\$7.50**

Jobbers and Dealers!

Write for attractive selling proposition and name of our nearest local factory representative.

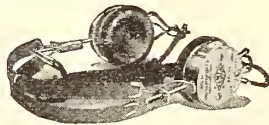

**BASCO** **Briggs & Stratton Co.**  
PRODUCT Milwaukee, Wisconsin

Showing One Phone

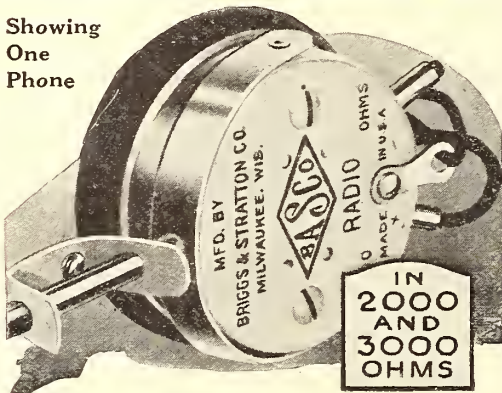

IN 2000 AND 3000 OHMS

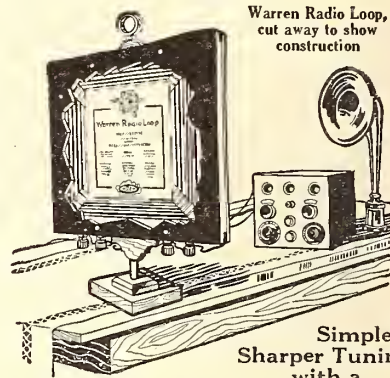

Warren Radio Loop, cut away to show construction

Simpler, Sharper Tuning with a

## Warren Radio Loop

**A**ERIAL and tuning device all in one. Tunes not only to wave length but to wave direction. An aid to selection. Eliminates atmospheric. All enclosed—damp and dust proof, fool-proof and surprisingly compact, neat and durable. Write to-day for Bulletin X-102 containing hookups.

A Type for Every set At the Best Dealers

- Type-A-737 (300-700 meters) 6 inches square—non-directional ..... \$10.
- Type-A-723G (175-1000 meters) 6 inches square—non-directional ..... \$12.
- Type-B-2537 (300-770 meters) 18 inches square—directional ..... \$20.
- Type-BL-2520 (200-18,000 meters) with honeycomb coil 18 inches square—directional ..... \$25.

V-DE-CO RADIO MFG. CO.

Dept. B Asbury Park, N. J.

## 6 Volt 120 A.H. RADIO BATTERY IN LEAK PROOF RUBBER CASE \$25.00

The Radio Battery You Have Been Waiting For

A high grade, long-life, 11 plate radio battery in absolutely leakproof rubber composition case with victoria style cover. Protects your rugs and floors from destructive acid. Makes your "A" battery as handsome as your receiving set.

**Positive 18 Months Guarantee**  
Guaranteed for full 18 months of service. Non-warping cedar separators, highest quality plates of generous thickness. 6 Volt—120 Ampere hour type. Sealed terminals save electrolyte and protect connections. Positively will not short circuit. Fitted with convenient handle and anti-drip tray.

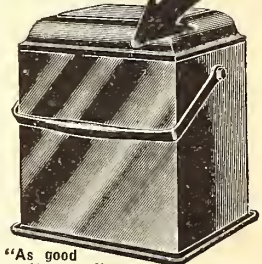

"As good as its name!"

Price, complete, fully charged, \$25.00. Neat switch in cover supplied for \$1.50 extra.

**NOTE THESE LOW "A" BATTERY PRICES**

Noble Radio "A" Batteries in Everlastic Rubber Cases			
Type	Rating	Plates	Price
Junior	80 Amp.	7	\$14.80
Senior	100 Amp.	9	17.90
Standard	120 Amp.	11	19.70
Superior	140 Amp.	13	21.70

Noble "A" Batteries in Maple Cases, Black or Mahog. Finish			
Type	Rating	Plates	Price
Junior	80 Amp.	7	\$12.75
Senior	100 Amp.	9	15.90
Standard	120 Amp.	11	17.75
Superior	140 Amp.	13	19.45

Covers for above batt. \$1 extra. You may be able to buy batteries as good as ours, but none that are better.



Address Dept. B

Order today, sending check or P. O. money order, or we ship express C. O. D. same day order is received.

**NOBLE BATTERIES**  
1454 MONADNOCK BLOCK - CHICAGO



## THE RADIO SET OF THE FUTURE

**I**T cannot be foretold what combination of units will be used, or the circuits that may be employed in the Receiver of tomorrow. It is obvious, however, that today's conventional set will soon be considered crude and antiquated.

Little prescience is required to realize that the panel of insulating material, with its shielded background, is doomed to obsolescence. The use of a great mass of expensive insulating material to provide for "live shafts" was merely a temporary expedient. Progressive practice has eliminated the electrical difficulties connected with live shafts and also obviated the necessity for massive insulation.

Carrying primary leads to the panel, and the drilling of numerous holes for a switch, will cease because of the waste such labor entails. To make the tap-switch an integral part of the instrument is the expedient thing to do.

Knobs add nothing to the appearance of a panel, and will in time become a relic of bygone days. The concave dial and bar control, giving ease of adjustment without cramping the hand, is far more sensible and attractive.

### EISEMANN PARTS AND PANELS

Permit changing circuits and re-location of parts on panel—all units being interchangeable.

Make unnecessary the use of shielding—the metal panel itself accomplishing this purpose.

Eliminate mounting of tap-switches and soldering of primary leads.

Give the many advantages of concave dials—a natural position of the hand in tuning, added attractiveness in appearance and ease in packing for transportation.

*Write for descriptive literature.*

### EISEMANN MAGNETO CORPORATION

William N. Shaw, *President*

BROOKLYN, N. Y.

DETROIT

CHICAGO



**EISEMANN**

# AUDIOLA CHICAGO

GET acquainted with Radio by buying an Audiola Crystal Receiving Set.

The 23-plate variable condenser insures sharp and accurate tuning. It is a complete unit, in a rich mahogany finished case, with nickel plated fittings.

Needs no batteries, no tubes, no fussing. Just connect it with aerial, ground and head phones, and "listen in."

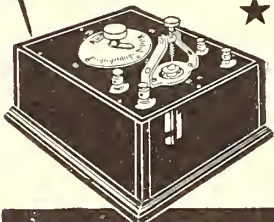

★ Price \$10 Complete

(without headphones)  
At your dealer or write direct for illustrated booklet.

Audiola Radio Co.  
430 S. Green St., Chicago

We can use a few high-class representatives for exclusive territory.

## 1200 MILES With a Crystal Set Using



★ THE WORLD'S GREATEST  
RADIO CRYSTAL

A Needles, California, radio fan writes:  
"Using M. P. M. Crystal, I picked up Los Angeles, San Francisco, Salt Lake, Denver and St. Louis. It is far superior to any crystal I have ever used."

Before Discarding Your Crystal Set for an Expensive Tube Outfit, Give M. P. M. Crystal a Trial

⚠ Beware of Imitations. The genuine Million Point Mineral is sold only in separate crystals packed by our company in boxes bearing the trade-mark "M. P. M."

Send 25c and name of your Radio Dealer for a sample M. P. M. Crystal—concert-tested and guaranteed. 35c for mounted Crystal.

M. P. M. SALES CO.  
Dept. B

247 So. Central Ave. Los Angeles, Cal.

# Wave Trap

TRADE MARK  
PATENT APPLIED FOR

The Missing Link  
in RADIO

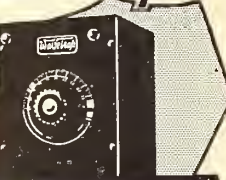

## Stops Interference!

The "WAVE TRAP" will eliminate interfering broadcasting stations and enable you to listen to your favorite station.

It will work on any set, greatly increase its selectivity and clearness, and eliminate code and spark stations.

It is mounted on a Formica panel in a handsome mahogany finished cabinet 6x5x6: It is a high grade instrument throughout and a valuable addition to the operation and appearance of any set. It comes to you complete and there are no extras to buy. It is installed in a minute by changing only one outside connection.

Use the "WAVE TRAP" for real results.

850 CHARGES PREPAID

Perbend Electric Co.  
19 E. SOUTH WATER ST.  
CHICAGO

☎ Circular on Request

## Waiting in the Wilderness

by ENOS A. MILLS

Adventures close to nature in the Rocky Mountains, with pleasant by-paths into the realms of animal lore. A book no one could help enjoying. Illustrated from 16 beautiful photographs. Net, \$2.50.

DOUBLEDAY, PAGE & CO. GARDEN CITY, N. Y.

# MARKO

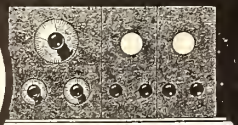

The Marko Quality for RADIO  
ALWAYS DEPENDABLE

MARKO STORAGE BATTERY CO.  
1408 Atlantic Ave. Brooklyn, N. Y. ★



The New  
**Pathé**

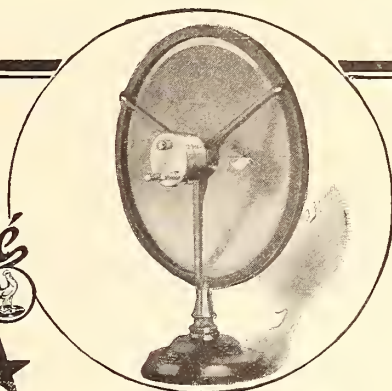

# Reproducing Revolutionized

Based on our experience of over a quarter of a century, as manufacturers of musical instruments—and as highly specialized accoustical engineers, we have produced the PATHÉ LOUD SPEAKER which will mark a new era in loud speakers.

It is something decidedly different. It utilizes an entirely *new* principle. And as a result it converts tone with an exactness never before accomplished by a "loud speaker."

No horn of any type is used. No small metallic diaphragm is hidden away at the end of a horn or in the depths of a cabinet. What you suppose on first inspection to be a stubby sort of a horn, is a parchment diaphragm of abnormal size.

WITHOUT DISTORTION the sounds are given directly from this diaphragm, propagating the waves in free air rather than by reflection from a horn.

The Pathé Loud Speaker possesses an unrivaled combination of distinct advantages. Briefly:—

It distributes the sound in all directions—and *does not* confine or "shoot" it toward one point as a horn does.

It does not require an extra battery. Simply attach it in place of the ear phones.

On the home sets of two steps of amplification it will flood the room with clear tone. On larger sets, it will produce any volume of sound required—WITHOUT DISTORTION.

It is compact, size 14½" high x 7" wide, and it will grace any living room.

The cost is much lower than you expect—

**\$24. for nickel finish**  
**\$22. for Japan Green finish**

If your dealer has not received his Pathé Loud Speakers, we will make you shipment direct from the factory. Simply enclose money order or check and say, send me The Pathé Loud Speaker.

**Pathé Phonograph & Radio Corporation**  
Dept. 4345      20 Grand Ave.      Brooklyn, N. Y.

## Send the Coupon

**Pathé Phonograph & Radio Corp.,**  
Dept. 4345, 20 Grand Ave., Brooklyn, N. Y.

Please send me the Pathé Loud Speaker.

I am enclosing \$\_\_\_\_\_. It is distinctly understood that I may return the Loud Speaker if it is not entirely satisfactory—and my money will be cheerfully refunded.

Name \_\_\_\_\_

Address \_\_\_\_\_

Town \_\_\_\_\_

**Pathé the World Over**



## The Meaning of the Star

THE chief danger in the development of radio is the prevalence of inferior and unsatisfactory apparatus. The demand for radio equipment that, for a time, could not be fully met by the manufacturers of standard goods, naturally flooded the market with radio sets and parts of poor design and slip-shod workmanship. Many new enthusiasts turned away with disgust because of failure resulting from this so-called "bootleg" apparatus. Much of it is still offered for sale with ridiculous claims at cut prices.

To Safeguard Its Readers, RADIO BROADCAST will permit manufactures to include a black star in the advertisements of sets, materials, parts, and accessories that have been tested by its experts and found to be worthy of indorsement. This approval will cover both design and workmanship.

The absence of the RADIO BROADCAST star will mean that the article advertised has not been offered for test and that this magazine's experts have not personally used it. The acceptance of an advertisement in itself indicates a belief in the integrity of the manufacturer. But, the appearance of the star means, in addition:

**Tested and Approved by RADIO BROADCAST**



# Read this again!!

## Filkostat Proven Best Filament Control

Radio Broadcast Advertiser, April, 1923

Comparison of Fine Adjustment Control Range of Filkostat With Rheostat and Other Filament Controls. Clearly, Filkostat Indicates Superiority, as it Permits Perfect and Gradual Current Increase With Infinitesimal Adjustments.

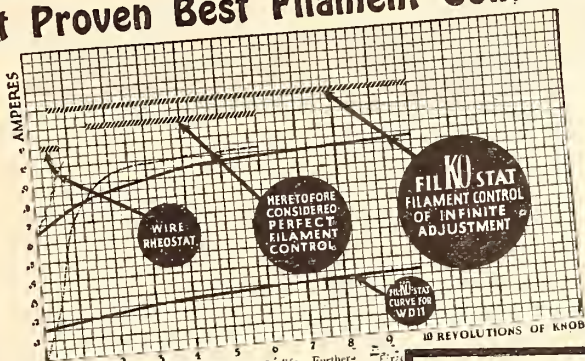

**I**n the Filkostat, a new filament control first perfected by S. R. Hippie, well known as an inventor of apparatus for the control of electric currents, which is distinctly designed to utilize the great tuning possibilities of the vacuum tube itself. Radio amateurs and manufacturers have been looking forward to the advent of just such a device. They have realized that all rheostats and other so-called filament regulators, are merely adaptations of pre-radio day devices, not capable of adjusting the infinitesimal gradations of filament HEAT which adjustments are essential to perfect tuning.

### PERFECT TUBE CONTROL

The Filkostat permits perfect regulation of filament heat. Since the heat emitted varies as the square of the current, fine current regulation becomes extremely necessary to accomplish. This governs the flow of electrons. Proper control of the electronic flow in the tube permits the very finest tuning conceivable. The fine adjustment of the Filkostat starts slightly before the tube begins to function. With other filament controls, what minute adjustment there is, starts when the filament is almost at maximum heat. Between 1800 degrees-

considerable increase in tube life. Furthermore, the extreme degree of fineness in increase and decrease of electronic flow by infinitesimal variations, makes the Filkostat control ideal.

The perfection of design including ample internal contact is the cause of this new instrument being non-microphonic, absolutely silent, and free from all noises.

### IDEAL FOR W D I T'S AND DX WORK

The lower curve on the graph above is eloquent testimony as to the Filkostat's adaptability to any dry cell tube. These tubes using only a fraction of an amperes demand an instrument that is so finely adjusted that this fractional current can be perfectly regulated. This the Filkostat accomplishes.

### OTHER FILKOSTAT FEATURES

The Filkostat has a definite off. It is so designed that the filament extinguishes abruptly indicating that the A battery supply is completely disconnected.

At full on the Filkostat resistance is practically zero.

The Filkostat consists of a hollow cylindrical container containing the special resistance material placed between two large adjustable contacts controlled by turning the knob.

The Filkostat is to all purposes "fool proof". It is compact in form, takes very little space on the panel and so mountable that it can replace any other control without readjustment.



of dull red glow—and 2050 degrees—white heat—the Filkostat control is so fine that increases of temperature of fractions of a degree, with corresponding variations of electronic flow from the filament to the plate, are obtainable.

### LONGER TUBE LIFE; NO NOISES

The initial brush of current prevents the crystallization of the filament which so many experts claim occurs when the current is fed too slowly at first as is done in other forms of filament controls. This means

THE RESISTANCE ELEMENT is so finely divided that no further division is possible. There are no disks to break or chip.

THE RESISTANCE REMAINS CONSTANT at any position eliminating current variations once set. Such variations are not apparent to the person tuning excepting in "fading out" of stations and noises. But in the laboratory, where such a test as that shown on the above graph can be made by anyone, this feature and all the other points of superiority of the Filkostat are immediately apparent.

The filament control of infinite adjustment

# FIL-KO-STAT

CURRENT INCREASE PERFECT AND GRADUAL LIKE THE RISING SUN

## \$200

—and here's why you need it!!

Designed For Vacuum Tube adjustment and not just an old method adapted to it.

**NOT a Rheostat**  
—but a REAL Filament Control.

**Infinitesimal Control—of filament heat**  
and therefore of electronic flow.

**Very Finest Tuning for DX**  
is realized with Fil-Ko-Stat.

**Controls Fractional Currents**  
—making it ideal for use with any dry cell tube.

**Fine Adjustment Starts**  
—where tube commences to function increasing the AREA OF FINE ADJUSTMENT CONTROL.

**Definite Off—**  
an important feature indicating complete 'A' Battery disconnection.

**Resistance Practically Zero**  
at "full on" there is practically no resistance in circuit.

**No Disks To Break or Chip**  
Resistance Element is so finely divided further division impossible.

**Absolutely Silent**  
The Fil-Ko-Stat is non-microphonic and operates free of all noises.

**Fahnstock Clips**  
and solder contacts on connection posts.

**Adjustable Mounting**  
—no re-drilling of panel necessary.

**GUARANTEED**  
The FIL-KO-STAT is to all purposes "fool proof". Each instrument is packed with the maker's guarantee that it will be replaced if broken within one year.

Replace Old Style Current Controls with the **NEW FIL-KO-STAT a real Filament Control**  
ON SALE AT RADIO DEALERS EVERYWHERE

Manufactured By



If your dealer has none in stock yet send \$2.00 and his name direct to  
SOLE INTERNATIONAL DISTRIBUTORS

**RADIO STORES CORPORATION**  
Dept. R. B. 218-222 West 34th Street, New York

# The Autostat

A Super Radio Rheostat

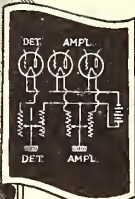
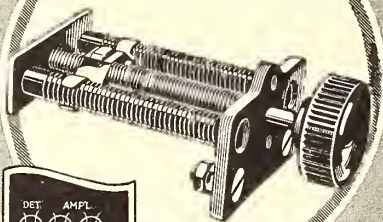

Can be used with 6-volt or WD 11 detector tubes, two amplifying bulbs or one 5-Watt power tube.

The difference between a jumbled mass of signals coming from everywhere and the "sharply-tuned" concerts received clearly and distinctly from far-away stations depends largely upon the careful adjustment of your detector filament current.

Heretofore, sharp tuning has only been partially obtained thru skillful "hair-breadth" manipulations of the filament rheostat. But with

# The Autostat

A Super Radio Rheostat

these much-sought-for results can be secured by anyone. Just "twirl the knob"—a full turn produces a finer adjustment than a "hair's-breadth" turn on any other.

Economical—neat—small—compact. No carbon to break or change resistance. Unqualifiedly guaranteed. Popularly priced—\$1.35.

If the Best is none too good for the set you are building or have bought, see the Autostat at any good radio or electrical dealer Today. Or write direct for Free Bulletin which shows why the Autostat is radio's Best rheostat.

**DEALERS — JOBBERS**

Write or wire for Radio's most attractive merchandising proposition.

THE AUTOMATIC ELECTRICAL DEVICES CO.  
128 WEST THIRD ST.  
CINCINNATI, OHIO

Builders of Precision Rheostats since 1914

## Convert Your Crystal Set Into Tube Set at Small Cost

You can now enjoy wider range, greater volume of sound and purer tone and do away with feeling around for a sensitive spot, if you make a Tube Set out of your Crystal Set by adding the Peanut Tube W. T. 501 and a few other inexpensive accessories. Full directions packed with every W. T. 501.

### Welsh PEANUT Detector Tube W. T. 501

can be used on three dry cells or one regular 6-V "A" battery. Consumes less than half as much current as ordinary tubes, consequently does not use up batteries as fast.

Nickel-plated socket, moulded base, double-spring contacts, 40c extra. Adaptor for standard V. T. Socket, 75c extra.

If not at your dealer's, send us his name and address with money order and we'll see that you are supplied. Include 10c extra for registration.



Radio Research Guild **\$2.00** Immediate Delivery  
40 Clinton St. Newark, N. J.

## HOW ABOUT— Your Summer Radio Reading Plans ???

Here's a chance to order RADIO BROADCAST for 5 months at reduced price. Just sign and send in coupon below

### Read these articles in RADIO BROADCAST for June—

- The New Westinghouse System of Broadcasting
  - Blind, but He Built His Own Radio Set
  - All About Our Boy Scouts Prize Contest
  - How to Build a Single Tube Loud Speaker
  - Operating a Radio on a Yacht in Mexican Waters
- FIVE BIG ISSUES FOR ONE DOLLAR!**

Doubleday, Page & Company **MAIL NOW**  
Dept. 523-R, Garden City, N. Y.

Enclosed please find \$1.00 for which special price kindly send me the next 5 issues of RADIO BROADCAST, commencing with June.

Name.....  
Address.....  
City..... State.....





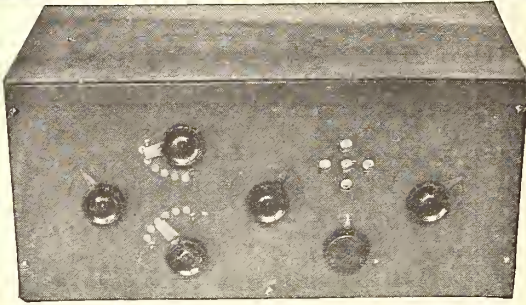

**HERE'S WHAT YOU GET FOR \$10**

1. "The How and Why of Radio Broadcasting"—the book and working charts that tell you just what you need to know about radio, free with each order until further notice.
  2. Parts for the receiver cabinet.
  3. Specially finished front panel.
  4. All the parts, including stators, rotors, axles, friction washers, rotor balls, and wire for two variometers.
  5. All the parts for one vario-coupler.
  6. Metal indicators.
  7. Control knobs for tuning devices.
  8. Vacuum tube socket.
  9. Rheostat.
  10. Wire for winding vario-coupler and variometers.
  11. Grid leak and condenser unit.
  12. Inductance switches for vario-coupler.
  13. Contact points for vario-coupler.
  14. Spring connectors for making an easy job of the wiring.
  15. Eight binding posts.
  16. Hard drawn copper wire for making substantial, bus-type connections.
  17. Metal foil for making the shield which cuts out "howling," due to "body capacity," effect.
  18. Complete soldering outfit, including soldering iron, solder, resin and scraper—just the thing for radio work.
- Everything is here to enable you to build a receiver, without any special tools, without requiring any knowledge of radio, without any complicated parts—but with all the advantages of an expensive receiver at about one-sixth its usual cost. And you have all the fun of making it.



**1300 Miles and More  
On a KD-10 Receiver**

Using a 2 wire antenna less than 40 feet above the ground and a receiver he built for \$10, Theodore Bedell, Jr., of Freeport, L. I., hears Havana, Cuba; Davenport, Iowa; Atlanta, Ga., and many other distant broadcasting stations.

**Just the Outfit for that Boy!**

Send money order to-day for a KD-10—the biggest \$10 worth you ever bought. Add postage for points outside the U. S. A.

We can also supply standard radio equipment of all makes at list prices.

**KAY DEE RADIO SUPPLY CO.**  
487 Fulton Street, Brooklyn, N. Y.

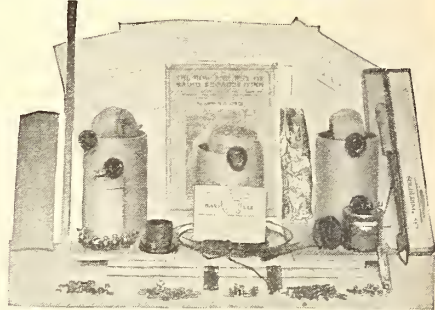

**ALL THESE PARTS FOR \$10**

**BROOKS VARIABLE CONDENSER**

Two Ribbons furnished (Max. .0005 Min. .00001)  
Easily interchangeable (Max. .001 Min. .00001)

Adaptable to all receiving circuits.

Shortening of plates eliminated.

Nicety of adjustment.

Straight line capacity curve.

Low internal resistance.

Loud Signals

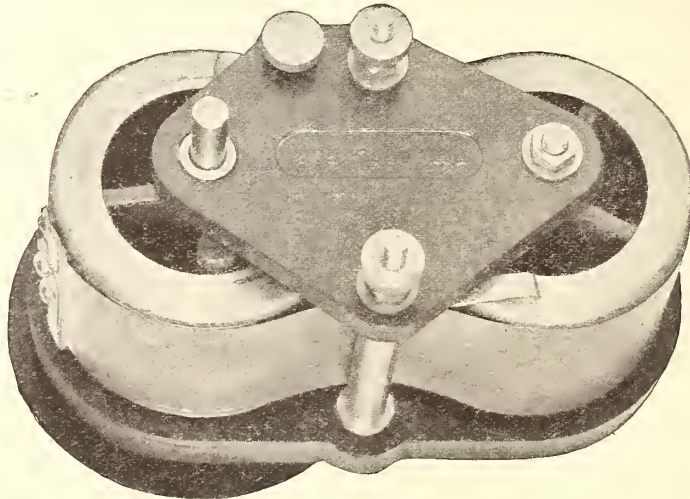

Jobbers Wanted

Write for prices and discounts

Retail price \$4.75 each, complete with dial.

Manufactured by

**METRIC METAL WORKS**

of

**AMERICAN METER COMPANY, INC.**

ERIE, PA.

★ Tested and approved by RADIO BROADCAST ★





# HAVANA!

Theodore Bedell, Jr.,  
operating the set he made.



## AT LAST!

You Can Now *Make*  
*Your Own Receiver* at a  
**TOTAL COST of ONLY \$10.00**

**T**HE HOW AND WHY OF RADIO BROADCASTING, by Arthur H. Lynch, is the book radio amateurs all over the country have been looking for. It is complete in every detail and makes it possible for you to build a modern set, capable of receiving over great distances, without interference.

To buy a similar receiver would cost you at least five times as much.

Four working patterns accompany each book and they are used for making the panel, cabinet and electrical units.

One of the receivers built by the author is in use in the office of "Radio Broadcast" and is giving entire satisfaction.

The set is designed for use with a single vacuum tube, but amplifiers may be used if desired.

The stations mentioned in this letter include two in Newark, N. J., two in New York; one each in Schenectady, Pittsburgh, Philadelphia and Atlanta, Ga., one in Havana, Cuba, ranging from 30 to 1350 miles. Still greater distances are possible.

39 Bedell Street, Freeport, N. Y.  
September 9, 1922.  
Doubleday, Page & Co.,  
Garden City, N. Y.  
Gentlemen:

It may interest you to know the results I am getting from the vacuum tube receiver I made from the plans which came with your pamphlet "The How and Why of Radio Broadcasting," by Arthur H. Lynch.

The stations of WJZ, WOR, WEAF and WBAV come in regularly and very clearly. Also, I receive from WGY, KDKA and WOO and have no trouble to tune them in over the above named stations.

**We hear Havana, Cuba, very well.** Being an amateur and with no radio experience whatsoever two months ago, I attribute the results I am getting to your publication, which is certainly complete and easy for anyone to understand.

In connection with the receiver, I use an aerial 100 feet long, 2 wires—2 feet apart, 40 feet high—and a 35-foot lead in. Also a single vacuum tube, a six volt storage battery and a 22½ volt "B" battery.

I also wish to state that the tone of reception is excellent, and in comparison with outfits owned by friends, costing five or six times as much as mine, my results compare favorably and in many instances surpass.

Yours very truly,  
THEODORE BEDELL, JR.

**This book tells you all you have to know:**

How to put up your antenna in accordance with the new regulations of the National Board of Fire Underwriters—

How to wind coils, drill the panel, make the cabinet, solder connections—shield your receiver—

How to operate your set intelligently—

How to overcome interference and other troubles—

How to prolong the life of your vacuum tube—

How to use "vernier" adjustments—

In short—everything you want to know about in radio language you can understand.

There are more than two dozen photos and diagrams in addition to the four working patterns.

**DOUBLEDAY, PAGE & COMPANY**  
Dept. RB-2, Garden City, New York

Gentlemen: Enclosed please find one dollar for THE HOW AND WHY OF RADIO BROADCASTING by Arthur H. Lynch. If not satisfied I can return this book within 3 days and have my deposit refunded.

Name.....

Address.....

# RADIO

— *“they last longer”*

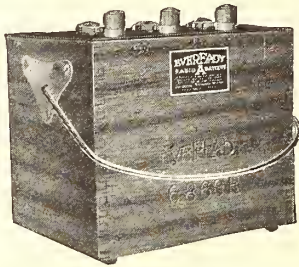

For Storage Battery  
Tubes use EVEREADY  
Storage “A” Bat-  
teries



For Dry Cell Tubes  
use EVEREADY  
Dry Cell Radio  
“A” Batteries



For All Vacuum  
Tubes use EVEREADY  
“B” Batteries

NATIONAL CARBON COMPANY, Inc.  
Long Island City, N. Y.

Atlanta Chicago Cleveland Kansas City San Francisco

*Insist on Eveready—  
Accept no Substitute*



**EVEREADY**  
**Radio Batteries**  
*—they last longer*



# MU-RAD RECEIVERS SUPREME



LIKE THE POWERFUL TELESCOPE that makes us neighbors to the stars, MU-RAD Receivers annihilate distance with delightful ease. Honolulu is as near to St. Louis by MU-RAD reception as New York.

So marvelously sensitive that it requires only a 2-foot loop aerial. Distinct reproduction with hair breadth selectivity, and yet easy for even a novice to operate. Conservatively guaranteed for 1000 miles.

*Write for literature*

*The New  
Star in  
the Radio  
World*



## MU-RAD LABORATORIES, INC.



803 FIFTH AVE. ASBURY PARK, NEW JERSEY

# Long distance

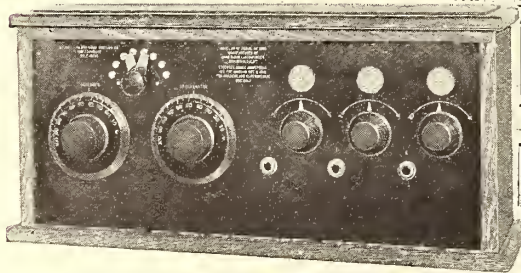
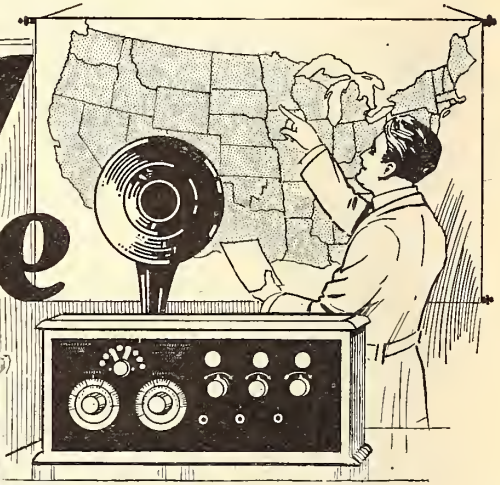

Licensed under Armstrong U. S. Patent No. 1,113,149, manufactured by Oard Radio Laboratories, Stockton, California, Atlantic-Pacific Radio Supplies Co., Sole Agents.

You are losing a vast amount of radio enjoyment every day you are without *Type AR-10 Long-Distance Regenerative Receiver and Two-Stage Amplifier*. It brings in distant programs, too. The reception of music and speech a *thousand miles* and beyond is considered not at all extraordinary by owners of this marvelous set.

It is simple, beautiful, sturdy, and efficient—a complete set of the most practical type with the latest accepted improvements.

And so compact—with WD 11 (“Peanut”) tubes there is room for both A and B batteries inside the cabinet, and only two external outlets are required, one for ground, and one for antenna. (Standard tubes can be used if preferred.)

The low price only possible because of quantity production and organized facilities of manufacturer, who is one of the oldest in radio.

Don't delay. For several months the demand for AR-10s will probably exceed the number that can be produced. Mail the coupon *NOW!*



## ATLANTIC-PACIFIC RADIO SUPPLIES CO.

650 Mission St., San Francisco, California

### MANUFACTURERS' REPRESENTATIVES

- Cutler-Hammer Mfg. Co. .... Rheostats and Potentiometers
- Alden-Napier Co. .... Sockets and Dials
- Carter Radio Co. .... Telephone Plugs and Jacks
- Dayton Fan & Motor Co. .... Variometers and Variocouplers
- A-P Quality Line. .... Transformers, Condensers, etc.
- Oard Radio Laboratories. .... Oard Phantom Receptor

**JOBBERS and DEALERS invited to stock these lines**

regenerative receiver with two-stage amplifier-

for \$75

Construction and Performance **FULLY GUARANTEED**

### MAIL THIS COUPON

Atlantic-Pacific Radio Supplies Co.  
650 Mission St., San Francisco, Cal.

Gentlemen:—Without cost or obligation, please mail me folder giving full information on your Type AR-10 Regenerative Receiver and two-stage Amplifier.

NAME \_\_\_\_\_

ADDRESS \_\_\_\_\_

CITY \_\_\_\_\_ STATE \_\_\_\_\_

*My favorite radio dealer is—*

NAME \_\_\_\_\_

ADDRESS \_\_\_\_\_

CITY \_\_\_\_\_ STATE \_\_\_\_\_





**Radiola V**

Mohogany finished case, of rugged build. A three tube Radiola—detector and two steps of amplification.

**Radiola RC**

Three tube set—detector and two step amplifier. Solid mahogany, attractively finished.

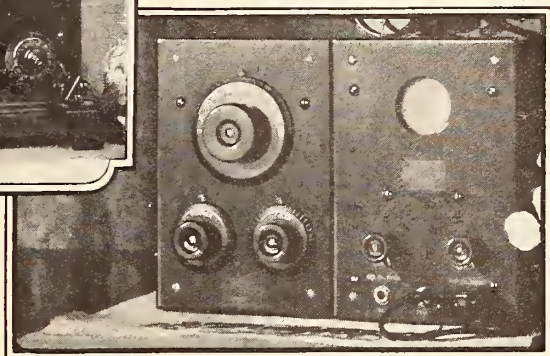

# A New Improvement Lowers the Cost!

Dry cells replace storage batteries. A new vacuum tube has made it possible. Radiola V and Radiola RC have been topping them all in popularity for dependability and long range—receiving over thrilling distances—up to 1,500 miles and more. Now both are converted to dry battery operation. This means greatly lowered cost—does away with bulky storage batteries—gives the far-away farmer the same good service it gives the city man.

No more need for expensive storage battery and charger. A big saving! And a saving made greater by the new offer—a combination offer of receiver and accessories—complete at a price remarkably low.

★ **“There’s a RADIOLA for every purse”**  
at the nearest Radio or Electrical Store

# Radiola

REG. U.S. PAT. OFF.

**Radio Corporation of America**

*Sales Department*

233 Broadway  
New York

*District Sales Offices*

10 So. LaSalle St.  
Chicago, Ill.

433 California St.  
San Francisco, Cal.

This symbol of  
quality is your  
protection



**Radiolala V or  
Radiola RC**

**Complete \$142.50**

*The New Way:* Complete for dry battery operation, including three WD-12 Radiotron vacuum tubes; head telephones; “A” battery consisting of three dry cells; “B” battery consisting of three 22½ volt units. \$142.50.

*The Old Way:* The price of Radiola V or Radiola RC when equipped for storage battery operation, formerly came to \$207.50.

*Send for this Free Booklet*  
There are Radiolas from \$25 to \$350. Send for the booklet that describes them all.

**RADIO CORP. OF AMERICA**  
Dept. 2066, 233 Broadway, New York  
Please send me your free Radio Booklet.

Name \_\_\_\_\_  
Street Address \_\_\_\_\_  
City \_\_\_\_\_ R. F. D. \_\_\_\_\_  
State \_\_\_\_\_

# New Equipment



A SOCKET FOR THE WD-11

This socket, made by the Alden Mfg. Co. of 52 Willow St., Springfield, Mass., is provided with a sub-base that makes the socket very substantial, and the spring contactors are arranged to make a wiping connection with the tube terminals. The price is 75 cents

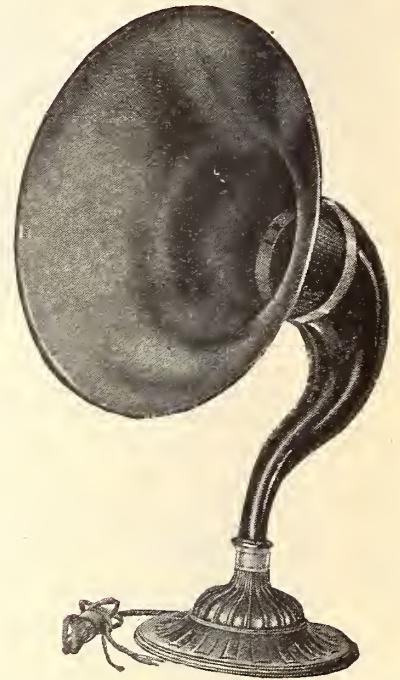

THE MUSIC MASTER

Is a loud speaker of exceptional quality. For use with two stages of A. F. amplification, it is hard to beat. Its tone is mellow, and the price is fair. The home model has a 14-inch horn and sells for \$30. General Radio Corporation, 624 Market St., Philadelphia, Pa.



THE SONOCHORDE

Is the first loud speaker to appear with a horn of gutta-percha. It is designed for use without any field-exciting current. It is indeed a quality instrument, made by The Boudette Mfg. Co., 79 Beach St., Revere, Mass.

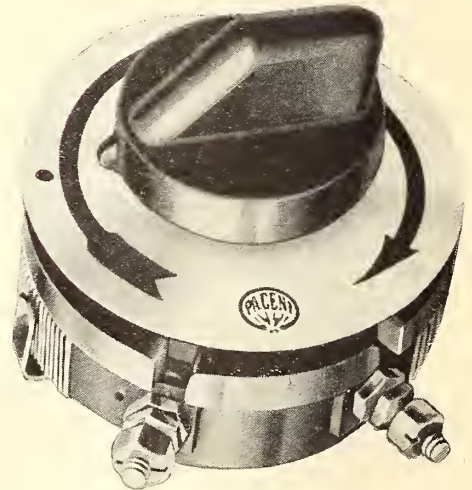

THE PACENT RHEOSTAT

Is mechanically and electrically good and its appearance is in keeping with that of the high-quality receiving equipment for which it has been made. Pacent Electric Co., 22 Park Pl., New York City



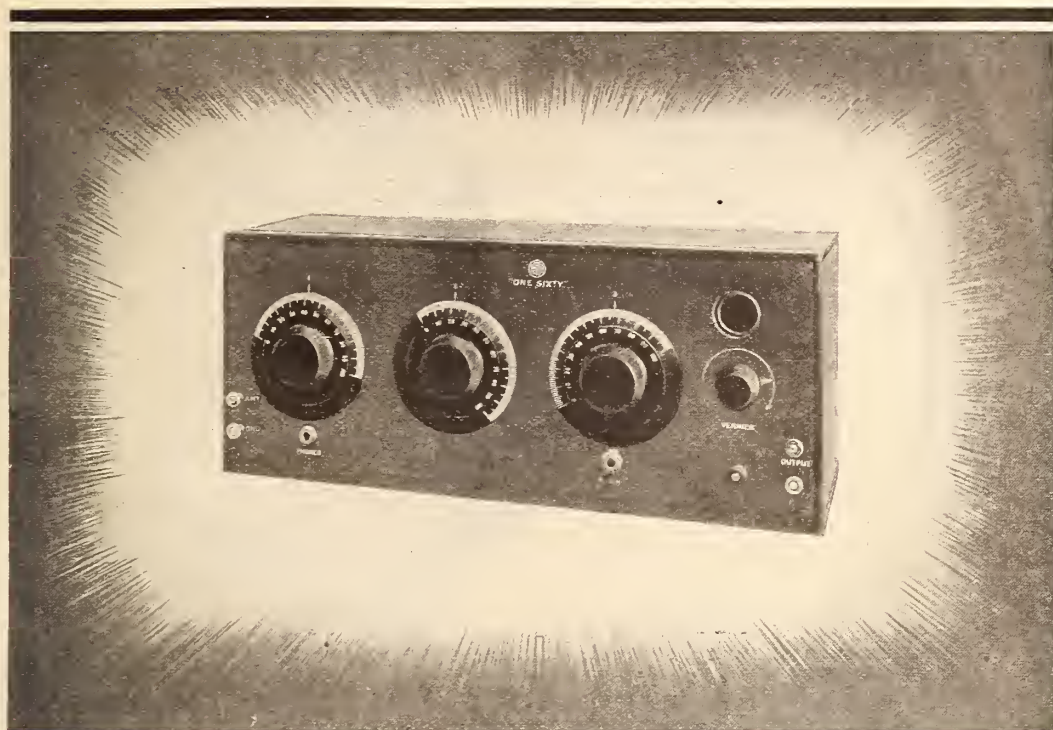

*The famous FADA "ONE SIXTY" with the NEUTRODYNE circuit*

## Neutrodyne



is the name given to a marvelous new radio receiver circuit invented by Professor L. A. Hazeltine of Stevens Institute of Technology, Hoboken, N. J. and used in the FADA "ONE SIXTY" receiver.

Only four vacuum tubes are used. The selectivity is remarkable and yet the dials can be adjusted to receive distant stations with great ease.

The FADA "ONE SIXTY" will receive broadcasted concerts from the Atlantic to the Pacific and with loud speaker intensity.

Denver, Colo., San Antonio, Tex., Havana, Cuba and Los Angeles, Calif. are some of the far distant stations listened to from New York City.

The FADA "ONE SIXTY" is the ideal receiver—the cost \$120.00.

F. A. D. ANDREA 1581-B Jerome Ave. New York City

*The* **FADA "ONE SIXTY"**  
- WITH THE NEUTRODYNE CIRCUIT -

# Cotogrip ★

"Built First to Last"

This little beauty was approved by our engineers only when convinced that they had produced the one socket that combines all the essential features of a good socket.

1. Positive Cotogrip Contacts.
2. Hard Rubber Insulation.
3. Rugged Construction.
4. Compact Design.
5. Concealed Mounting.

It is impossible to show the unique mechanical action of Cotogrip contacts in a photograph. It is different from any other socket you have ever seen. This socket will interest you in every way.

You ought to have one.  
Ask Your Dealer



## COTO-COIL CO. PROVIDENCE

Pacific Coast Branch, 329 Union League Bldg., Los Angeles, Cal.

### WHY METRO HEADPHONES ARE SUPERIOR



#### ACTUATING COIL CORES

METRO HEADPHONES faithfully reproduce every sound variation so that reception is always clear and natural. The magnetic current which operates the diaphragm is transmitted by the actuating coils through the soft Armco Iron Cores, which allow a ready change of magnetic strength.

It is this remarkable ability of the actuating coil cores to react faithfully to every magnet impulse that helps to produce Metro sensitivity. A small detail, but perfection is made up of such details. Insist upon Metro Headphones because you can be sure that every detail is as it should be.

\$6.00



**Little Giant Receiving Set**  
A surprisingly compact set. Simplest tuning device. Complete with Metro Head-  
phones. . . . . \$14.00

**Metro Wave Selector**  
Makes any set highly selective. Completely separates 360 from 400 meters. . . . \$7.50

**METRO ELECTRICAL CO., Inc.**  
Manufacturers of Metropolitan Radio Products  
67 Goble Street Newark, N. J.

★ Tested and approved by RADIO BROADCAST ★





## *A Real Musical Instrument*

**ACTUAL** re-PRODUCTION, of the artist's music as broadcasted, is at last attained in the Atlas Amplitone Loud Speaker, without blast or distortion. The artist's personality breathes again in the full, natural, vibrant tones of the Amplitone Re-PRODUCTION. Musical critics and radio fans, who have heard the Amplitone, agree that, at last, the musical superiority of even the finest phonographs has been surpassed.

Embodies exclusive acoustic principles including the marvelous double diaphragm.

# *Atlas* **AMPLITONE** LOUD SPEAKER

**NO** loud speaker is perfect, unless it can be adjusted to your own individual set. The Atlas Amplitone is adjustable to any set. Complete with connecting cord

**\$25.00**

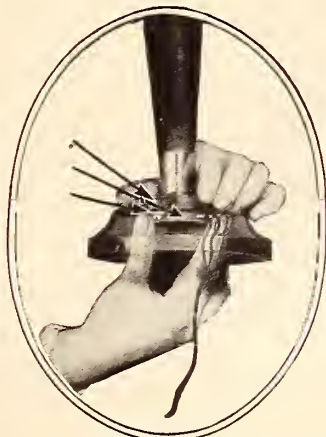

♦ ♦ ♦  
The Atlas Amplitone Unit, (without base or horn), with Grafonola Attachment, for use with your own horn or base, or to convert any phonograph (except the Brunswick) into a loud speaker.

**\$13.50**

Write for illustrated booklet and the name of your nearest *Amplitone* dealer. No other loud speaker can take the place of the *Amplitone*.

**Multiple Electric Products Company**  
5 Orange Street

Newark, N. J.

# New "UNITED" Vernier

A Miracle-Worker In Fine, Selective Tuning. Operates on a New Principle.

Will bring in the elusive stations that have thus far defied you, by giving at least *twice* as fine a tuning as has ever been possible with the best condensers thus far developed.

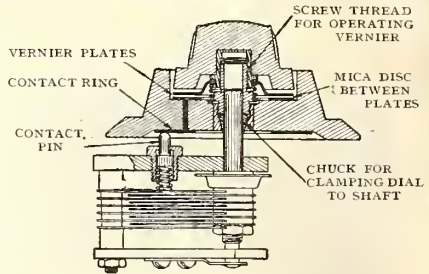
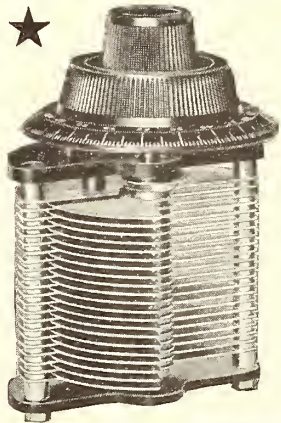

Can be attached to any plate condenser, by drilling one hole in top plate. Price, each Postpaid \$2.50.

## "UNITED" VARIABLE CONDENSERS WITH NEW VERNIER

43-plate—each \$6.50    23-plate—each \$6.00  
11-plate—each \$5.50

## "UNITED" TRANSFORMER

Audio Frequency. Amplifies detected signals so they come in clear and strong, for either headphone or loudspeaker reception. Each \$4.50.

Send for catalogue of United Products

## UNITED MFG. & DISTRIBUTING CO.

536 Lake Shore Drive  
New York Office  
50 Church St., New York, N. Y.

CHICAGO, ILL.  
San Francisco Office  
709 Mission St., San Francisco, Cal.

## CHARGE YOUR BATTERY WHILE YOU SLEEP

Hook the Leich NON TUNE Rectifier to your battery after the evening's entertainment and let it charge all night—no danger—you needn't watch it.

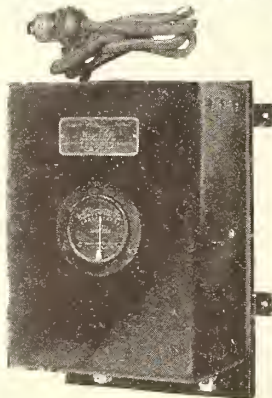

Its 2 ampere charging rate is sufficient for home use when three or four 5-watt tubes are operated.

With the increased use of quarter ampere tubes the NON TUNE Rectifier will soon be in a class by itself; because of its high efficiency it uses less than 40 watts of current at full load.

NON TUNE FEATURE gives this charger flexibility in its operation, allowing for considerable voltage and frequency variation of the power circuit.

A PATENTED RELAY LOCK keeps the battery circuit open when the power current fails.

LEADING RAILROAD COMPANIES have used NON TUNE Rectifiers for years.

Try a NON TUNE. Ask your dealer or write for Bulletin 100-A.

**LEICH ELECTRIC CO., Mfrs., Genoa, Ill.**  
Non Tune Rectifiers—Leich comfortable headphones

## DANIEL BOONE

*Wilderness Scout*

by Stewart Edward White

An out-of-doors story for fathers and sons

At bookstores, \$1.75

Doubleday, Page & Co.

## Tune In To

### WDAP

—the powerful broadcasting station at

# The DRAKE

Lake Shore Drive and Upper Michigan Avenue  
CHICAGO

From Porto Rico to lonely ranches in Alberta and Saskatchewan, from sunny San Diego to Quebec, and even a thousand miles out in the Atlantic and Pacific oceans, programs from THE DRAKE are picked up. You'll be particularly well repaid by tuning in Tuesday, Thursday, Saturday, and Sunday evenings—concerts include selections by THE DRAKE Ensemble Orchestra.

WDAP Station is but a single interesting feature of THE DRAKE, Chicago's finest hotel. When in Chicago be sure to stop at THE DRAKE. See how concerts are broadcasted, and enjoy the world famous service and surroundings of this wonderful hotel. Information on request.

Under The Blackstone Management, the world's standard in hotel service.



# “Having time of my life getting most splendid results from the ‘Socostat’” says one radio fan

(Socket and Rheostat)

THE “Socostat” is a combination of socket and rheostat that eliminates the wiring of two separate parts. Saves time, material and money.

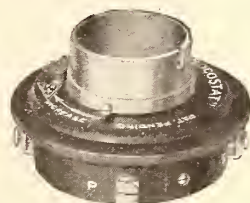

Single-unit socket and Rheostat for Table or Panel Mounting

No exposed wires. The internal rheostat permits very sensitive filament adjustment. Tube noises reduced to a minimum. Bakelite base and cover. Nickel plated receptacle takes any standard detector and amplifier tube. Rings and screws all nickel plated. The “Socostat” simplifies your construction and improves the appearance and operation of your set. Guarantees a smooth and positive contact.

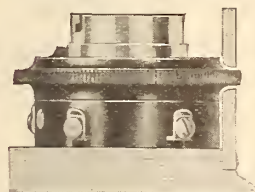

View showing panel mounting of “Socostat”

We guarantee that you will be satisfied.

Price \$2.50 at your dealer or write.

Another radio expert writes: “The ‘Socostat’ practically eliminates the usual tube noises and gives better results than the socket and rheostat in every way. Have shown it to several of the boys and all agree that it is O. K. It should go big with the Radio Bugs.”



View showing cover and ring removed.

## FEDDERS MANUFACTURING CO., INC.

59 Tonawanda Street

Buffalo, N. Y.

# RADIO ADVANCES and LUDWIG HOMMEL & CO. DEALERS WITH IT

**DISTRIBUTORS FOR  
Radio Corporation of America**

**RCA**  
Westinghouse General Electric  
Acme Atwater Kent Baldwin  
Brach Brandes Burgess  
Chelsea Clapp-Eastham  
Cunningham Cutler Hammer  
Dubilier Fada Fahnestock  
Formica Frost General Radio  
Hipco Homecharger Hopewell  
Kellogg Kennedy Klossner  
Murdock Omnigraph Pacent  
Radio Service Radiall (Amperite)  
Remler Rhamstine Tuska  
Western Electric  
and other Leading Manufacturers



Established radio dealers will recall the hectic days of last spring when any radio material could be sold and standard makes were at a premium.

Radio has become more stabilized, and crude material has given way to perfected apparatus. Your trade will want the newest and best in Radio. Can you satisfy the demand for:

- Vernier Condensers
- Vernier Rheostats
- Vernier Adjusters for Variometers
- WD-11 Socket Adapters
- Coupled Circuit Tuners
- Radio Frequency Sets
- Console Type Dry Cell Tube Sets
- Power Amplifier Loud Speakers

Ludwig Hommel & Co. dealers have these items illustrated in Hommel's Encyclopedia of Radio Apparatus and are kept in touch with all developments in the art.

**It pays to tie up with a jobber who wholesales exclusively and gives his dealers 100% service.**

**Send your next order to Hommel's and ask for our new Illustrated Encyclopedia 225 B. It's free to dealers.**

## LUDWIG HOMMEL & CO

530-534 FERNANDO ST.



PITTSBURGH, PENNA



Na-ald Special Socket No. 499

### It's the contact that counts

The Na-ald Special Socket No. 499 is a sturdy little socket for the G. E. No. 199 dry cell tube. It has special slot construction, is moulded from genuine Bakelite, and because of thorough cure and high dielectric properties it keeps plate to grid losses at a minimum (of particular importance in Flewelling Circuit, or in Radio Frequency).

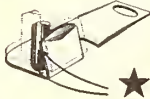

The Na-ald De Luxe V. T. Socket is of highest quality throughout. Its laminated phosphor bronze strips press firmly with a side wipe action on the contact pins, keeping surface clean and insuring perfect contact.

★ Send stamp for dial, small-space socket, condenser and R.F. transformer circulars

These sockets retail at 75c. each



Na-ald De Luxe, No. 400

**ALDEN MANUFACTURING CO.**  
formerly Alden-Napier Co.  
Dept. B, 52 Willow St., Springfield, Mass.



Booklet with wiring design instructions for Hazeltine's Neutrodione and the Flewelling Super-regenerative Circuits, and a number of standard circuits, packed with each socket.

### "Circuits of Victory"

By A. Lincoln Lavine

\$3.00 at your bookstore

Doubleday, Page & Co., Garden City, N. Y.

## FREE CATALOGUE

Make D X Records  
With D X Supplies

This Catalogue should be called "Recipes for Long Distance." It was written to help amateurs pull in the most distant stations.

To Get Your Copy  
Write Department 1471

**D-X Radio Company**

123 Liberty St.

New York City





## Rich Resonance that Only WOOD Can Give

14-inch Amplifier complete, \$30  
21-inch Amplifier complete, \$35

### JOBBER — DEALER —

A MUSIC MASTER will be sent to you with full privilege of return. Write for full description of the GERACO line, and prices.

THEY call MUSIC MASTER the "Stradivarius Among Amplifiers." For its horn is WOOD, with that pure, mellow-sweet tonal quality of the human voice that wood alone can simulate. (Phonograph experts proved the principle before radio.)

A powerful amplifying unit in the art-metal base of MUSIC MASTER sends sounds up through a cast-aluminum "gooseneck"—cast-aluminum, so it won't vibrate. This conveys true tones to the wooden horn, where they are beautifully enriched, humanized and given to the audience as they are actually sung, played or spoken.

There is only one MUSIC MASTER: Get it and you won't regret it! Hundreds of orders are pouring in daily. Demand actually exceeds supply, so get your order in NOW! Comes complete, ready to attach in place of head phones. No extras to buy. Hear MUSIC MASTER at your dealer's to-day. COMPARE it with any other amplifier, regardless of price! Literature on request.

Ask about the GERACO Phonograph attachment which makes an efficient radio loud-speaker of your Victrola or Columbia. Only \$10.

## GENERAL RADIO CORPORATION

Makers and Distributors of High-Grade Radio Apparatus

Walter L. Eckhardt, President

CHICAGO

624-628 Market St., PHILADELPHIA

PITTSBURGH



# ECHOPHONE

## Regenerative Radio Equipment

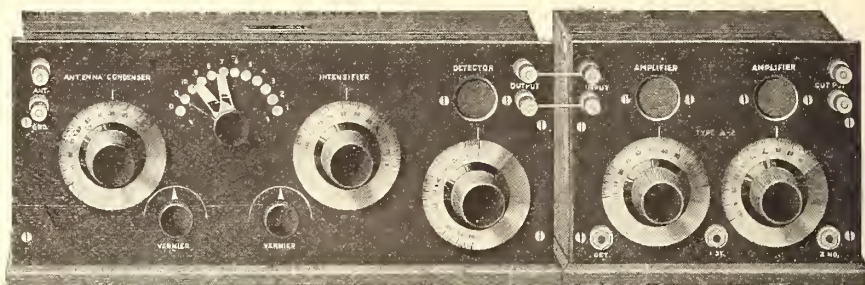

Licensed under Armstrong Patent No. 1,113,149

The Lowest Priced GOOD Radio Set on the Market

THE latest word in radio development. Made in various types. It has proved results in **long-distance reception**. Has unusual ease of operation for the beginner. Can be used with headphones or loud-speaker. Made by the Radio Shop of St. Louis, Mo., and Sunnyvale, Cal., having 10 years' experience in making dependable radio sets on sound engineering principles.

Prices Range from  
\$70 to \$160

**ECHOPHONE CORPORATION**  
1922-28 Chestnut St. St. Louis, Mo.

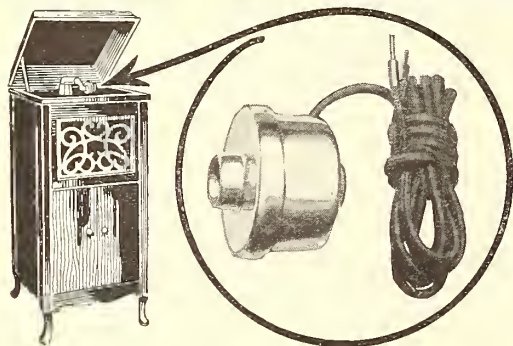

### RADIO LOUD SPEAKER for Phonographs

The MORRISON Loud Speaking Unit, for use on phonographs, takes the place of awkward headsets. Possesses a tone value 100% true—an achievement never before attained in a loud speaker.

#### Attaches in Place of Reproducer

Slips on tone-arm of phonograph in place of reproducer, or can be used with horn. Adapted to any bulb set with one or more stages of amplification. Adjustable from soft to loud tone. Cannot possibly rattle or loosen through excessive amplification. A popular-priced Loud Speaker that compares with most expensive instruments on the market. Thousands in use giving perfect satisfaction. Handsomely nickel plated, complete with 5 ft. cord, \$10—at your dealer's or direct. Sent C. O. D., if desired. Fully guaranteed. Money back if not satisfied. (When ordering, specify make of phonograph).

**MORRISON LABORATORIES, Inc.**  
Dept. 10, 536 Griswold St. Detroit, Michigan

### Increase the Efficiency of Your Set With a ★ PROUDFOOT VERNIER CONDENSER

#### Special Features

Plates Cannot Short Fool Proof  
No Adjustments to Get Out of Order

Two Dials But Only One Knob—one dial to indicate position of group plates and one to show relationship of vernier to group plates.

Higher Efficiency—the vernier plate being one of the group plates, allows the vernier adjustment without the additional electrical losses due to the usual construction of the vernier being separated from the main plates.



STYLE	M. F. CAP	PRICE
11 plate	.00025	\$5.00
21 "	.00055	6.00
43 "	.0011	7.00

**CRUVER MFG. COMPANY**  
2456 W. Jackson Blvd. Chicago, Ill.

The most satisfactory book for beginners that has yet appeared.—Public Ledger.



### RADIO SIMPLIFIED

By KENDALL & KOEHLER  
Radio Instructors

#### WHAT TO BUY HOW TO BUILD HOW TO OPERATE

A clear explanation of Radio in simple language with complete directions for assembling and installing home radio equipment. Will aid you in getting the best results from your set.

96 Illustrations including picture diagrams showing hook-ups, etc. Cloth, 250 pages, \$1.00.  
On sale at Booksellers or mailed on receipt of price  
**THE JOHN C. WINSTON CO., 34Winston Bldg., Philadelphia, Pa.**





CATALOGUE NO. 85

## An Improved RHEOSTAT another PACENT development

SIMPLE—STURDY—FINELY ADJUSTABLE—EASY TO MOUNT

You'll welcome the many advantages in the new PACENT RHEOSTAT. It is beautifully constructed, flawless in performance, the simplest to assemble or take apart when mounting. The turn of one screw separates the two units (as illustrated). Unit 1 consists of the pointer, knob and shaft moulded in one piece. Unit 2 remains intact when rheostat is separated, permitting the careful contact adjustment made at factory to remain undisturbed. Changing from panel to table mount-

ing is simply a matter of a few seconds. The wire element will safely carry  $1\frac{1}{2}$  Amp. continuously. The base of the rheostat is heat-resisting and will not crack or warp. The rheostat turns with the smooth "velvety" feel of precision instruments, making perfect control easy. Another instance of PACENT quality at reasonable cost.

The PACENT Potentiometer (same size and incorporating all of the advantages of the PACENT rheostat) Catalogue No. 88, \$1.25.

*Write for Descriptive Bulletin B-5*

## "DON'T IMPROVISE—PACENTIZE" PACENT ELECTRIC COMPANY

INCORPORATED

Executive Offices: 22 Park Place, New York, N. Y.

SALES OFFICES

Chicago  
Philadelphia  
San Francisco

Washington, D. C.  
Minneapolis  
St. Louis



Canadian and British Licensees:  
Colonial Radio, Ltd., Hamilton, Can.  
Members, Radio Section, Associated  
Mfrs. of Electrical Supplies

★ Tested and approved by RADIO BROADCAST ★

12187 125

**XX Grade  
is right  
for  
Radio**

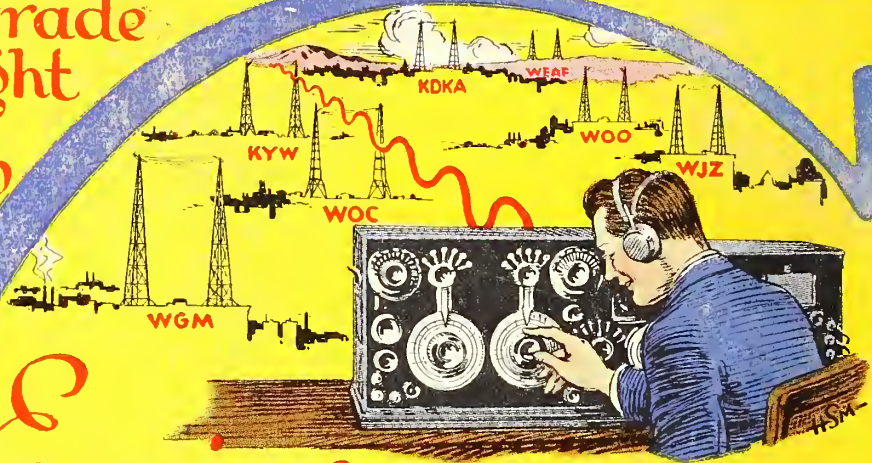

**Easier to Pick 'em  
with Proper Panels!**

★ Program-choosing demands delicate tuning and your radio panel must be right if you want to get and *keep* a station without variations and interferences. For panels, bases and partitions, no other material is more satisfactory than tough, unchanging, handsome Bakelite-Dilecto, XX grade

***bakelite-dilecto!!***

**[A Laminated Phenolic Condensation Product]**

Where protection of lives, homes, ships, cities and national safety depend on Radio, Bakelite-Dilecto panels are found in use.

Bakelite-Dilecto resists heat, water, steam, oils, solvents and the milder acids. Cannot warp or swell. Made in sheets, rods, tubes and special shapes in black and brown for all insulation requirements.

Accepting the next best thing to Bakelite-Dilecto will not do if you seek highest radio results. Any electrical dealer can get it cut and drilled to size for you. Write us direct for complete story of wonderful Bakelite-Dilecto.

***The Continental Fibre Company***

Factory: Newark, Delaware

Service From:

New York, 233 Broadway  
Chicago, 332 S. Michigan Avenue  
Pittsburgh, 301 Fifth Avenue  
San Francisco, 75 Fremont Street  
Seattle, 95 Connecticut Street  
Los Angeles, 411 S. Main Street

★ Tested and approved by RADIO BROADCAST ★

THE COUNTRY LIFE PRESS, GARDEN CITY, NEW YORK









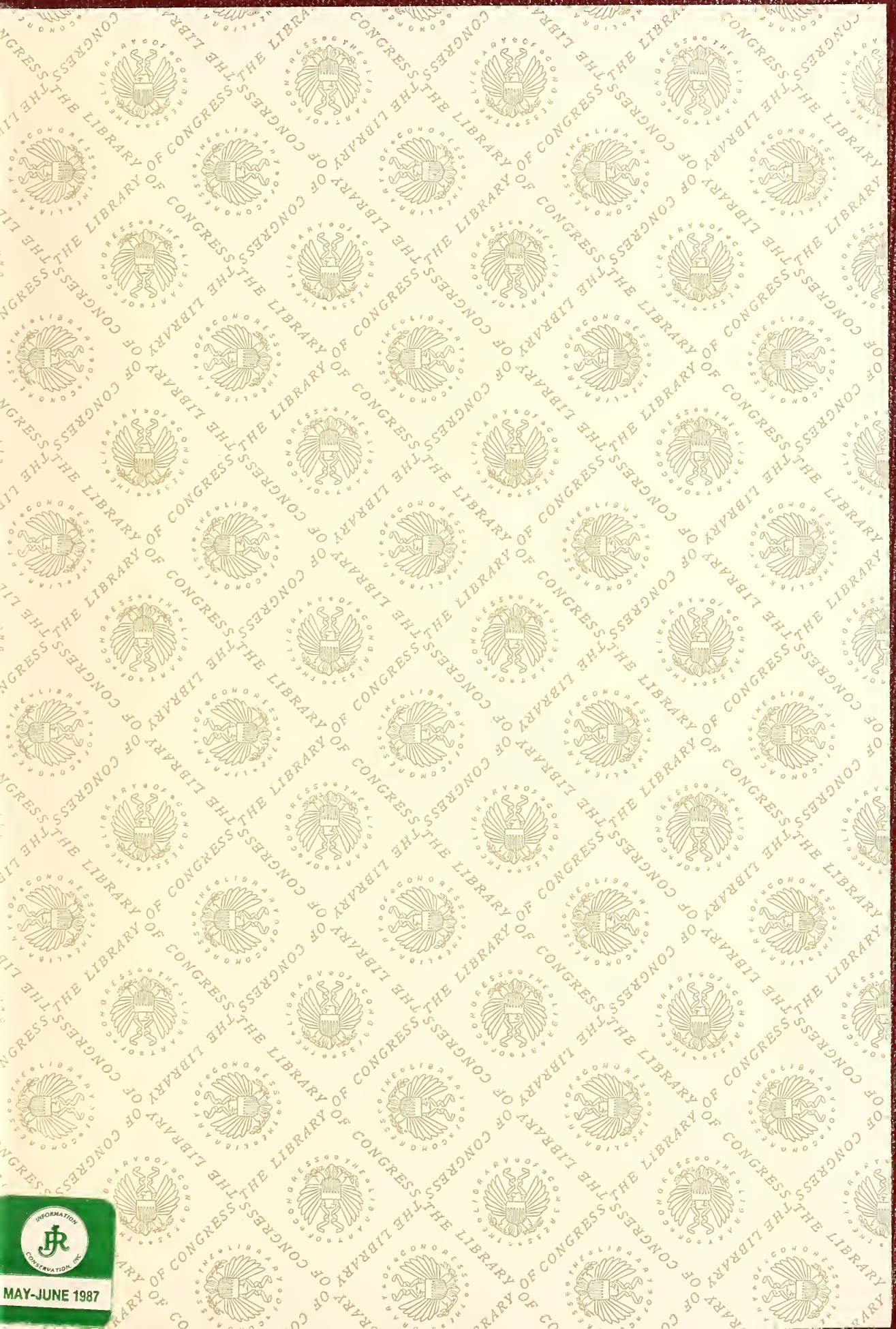



LIBRARY OF CONGRESS



0 020 249 883 8