

LIBRARY OF CONGRESS.

Chap. *AE* Copyright No. ....

Shelf *N 56*

UNITED STATES OF AMERICA.





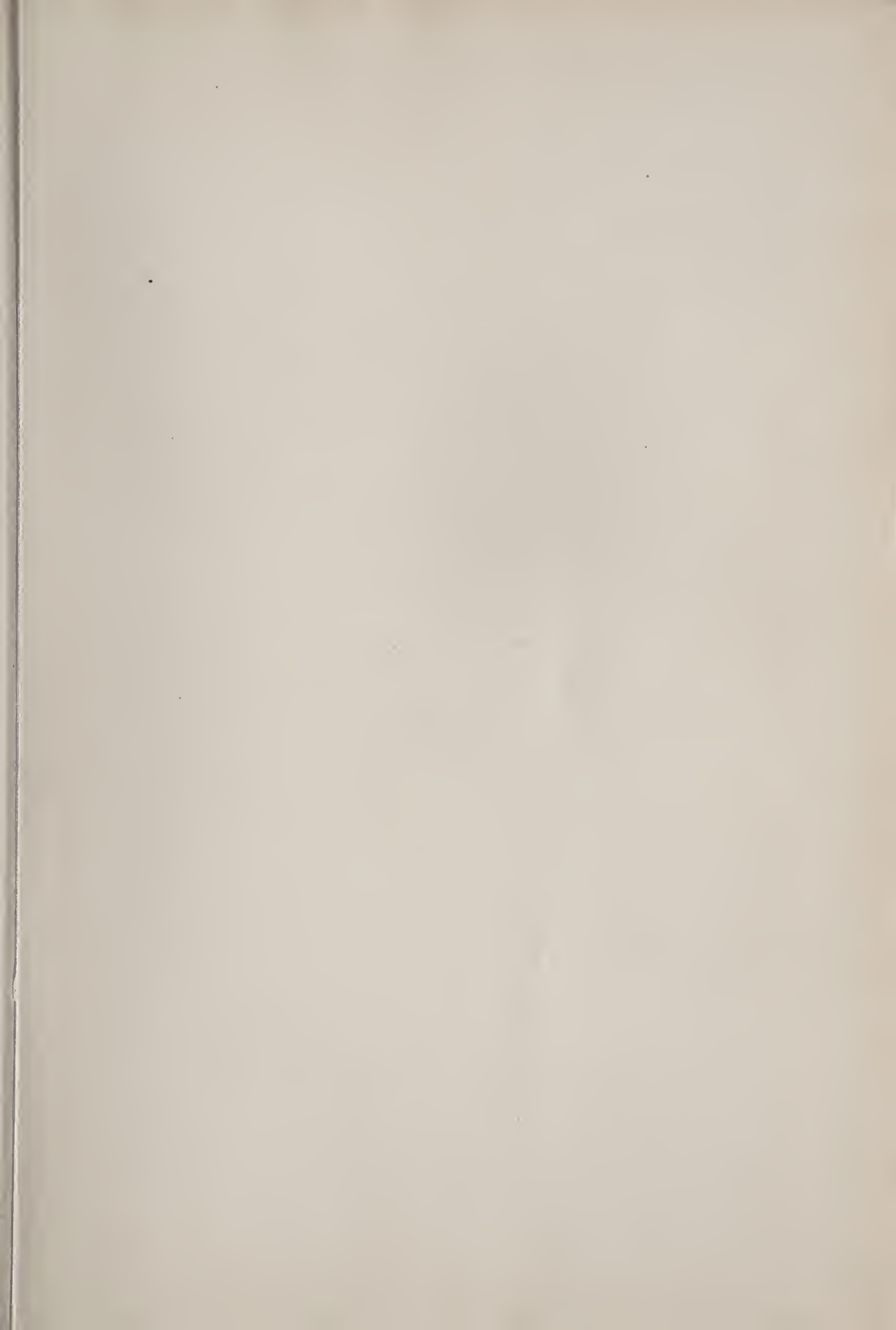

FIRST COPY,  
1899

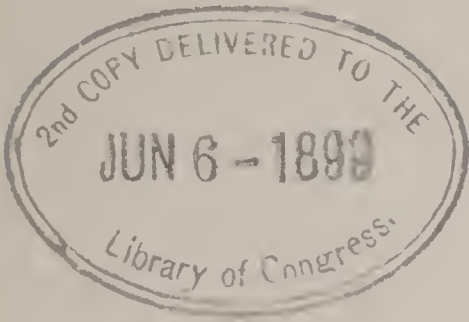

FEB 27 1899

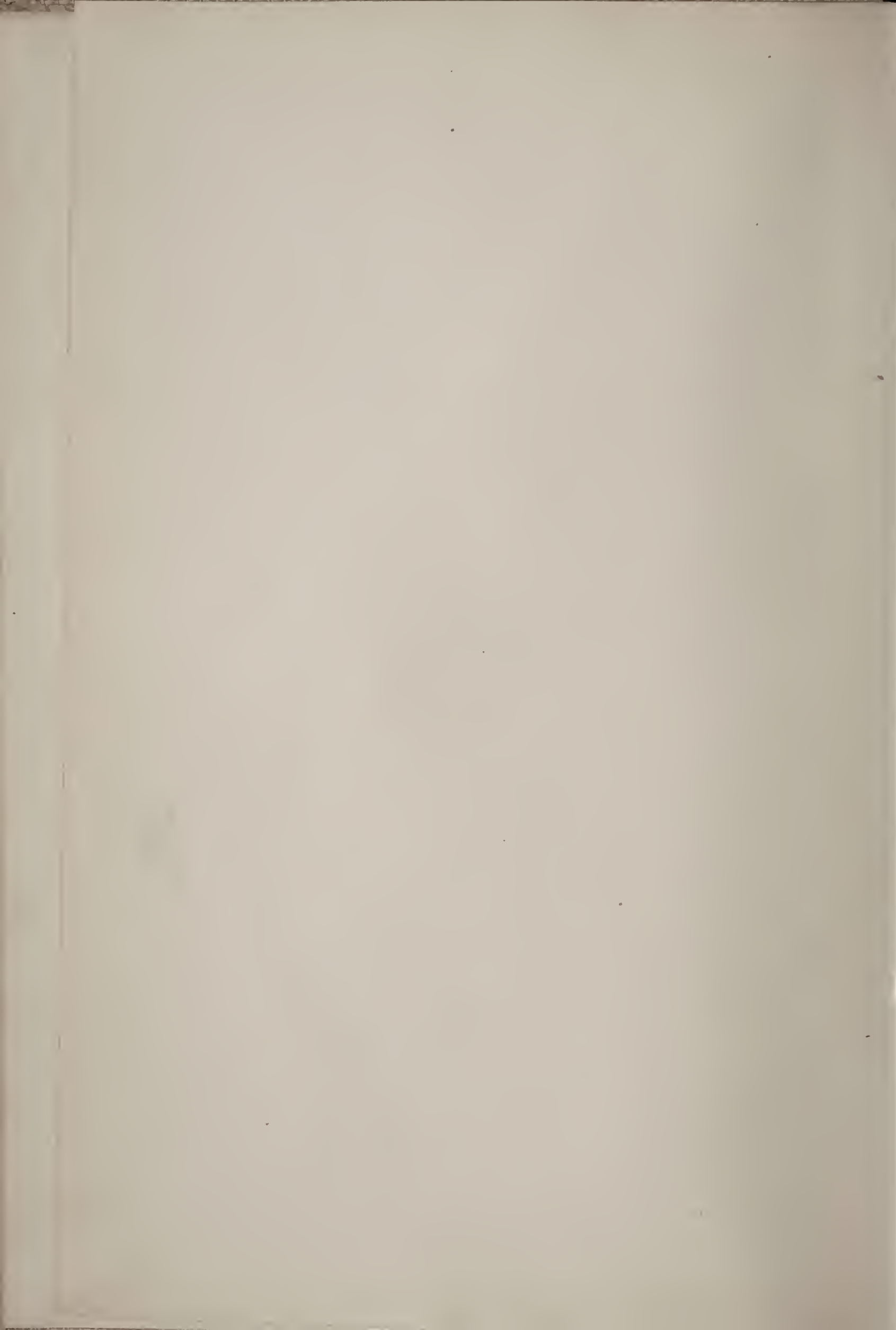



THE NEW  
NATIONAL CYCLOPÆDIA



✓

THE NEW  
NATIONAL CYCLOPÆDIA  
AND TREASURY OF KNOWLEDGE.

A HANDY BOOK OF READY REFERENCE FOR SCHOOLS.

THE ARTICLES RELATING TO AMERICA EDITED BY  
AINSWORTH R. SPOFFORD, LATE LIBRARIAN OF CONGRESS,  
AND EDITOR OF THE "LIBRARY OF CHOICE LITERATURE."

THE ARTICLES RELATING TO EUROPE EDITED BY  
CHARLES ANNANDALE, M.A., LL.D.,  
EDITOR OF THE "IMPERIAL DICTIONARY," ETC.

—THE WORK COMPRISES—

A CYCLOPÆDIA OF GENERAL KNOWLEDGE.

A DICTIONARY OF HISTORICAL EVENTS.

A COMPLETE ATLAS OF AUTHORIZED MAPS.

A LIBRARY OF BIOGRAPHY.

A GAZETTEER OF THE WORLD.

---

VOL. II.

---

TOLEDO, OHIO :  
THE BROWN, EAGER AND HULL CO.

1899.

L

AE5  
.N56

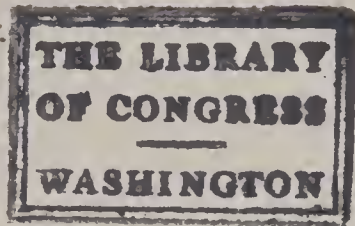

35665

---

COPYRIGHT, 1899, BY  
THE GEBBIE PUBLISHING CO., Limited.

---

TWO COPIES RECEIVED.

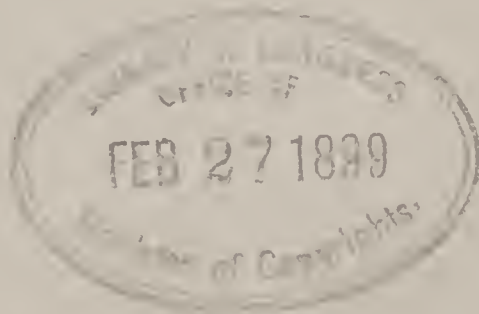

15149  
Feb-25-99 \*

15

21

Recent price 18 Apr 33

## KEY TO THE PRONUNCIATION.

The pronunciation of the words that form the titles of the articles is indicated in two ways: 1st, By *re-writing* the word in a different form and according to a simple system of transliteration. 2d, By marking the syllable on which the chief *accent* falls. Entries which simply have their accentuation marked are English or foreign words that present little difficulty, and in regard to which readers can hardly go far wrong. A great many of the entries, however, cannot be treated in this way, but must have their pronunciation represented by a uniform series of symbols, so that it shall be unmistakable. In doing this the same letter or combination of letters is made use of to represent the same *sound*, no matter by what letter or letters the sound may be represented in the word whose pronunciation is shown. The key to the pronunciation by this means is greatly simplified, the reader having only to remember one character for each sound. Sounds and letters, it may be remarked, are often very different things. In the English language there are over forty sounds, while in the English alphabet there are only twenty-six letters to represent them. Our alphabet is, therefore, very far from being adequate to the duties required of it, and still more inadequate to represent the various sounds of foreign languages.

The most typical *vowel* sounds (including diphthongs) are as shown in the following list, which gives also the characters that are used in the Cyclopaedia to show their pronunciation, most of these being distinguished by diacritical marks.

ā, as in <i>fate</i> , or in <i>bare</i> .	<i>eu</i> , a long sound as in Fr. <i>jeune</i> , = Ger. long
ä, as in <i>alms</i> , Fr. <i>âme</i> , Ger. <i>Bahn</i> =á of Indian names.	ö, as in <i>Söhne</i> , <i>Goethe</i> (Goethe).
â, the same sound short or medium, as in Fr. <i>bal</i> , Ger. <i>Mann</i> .	<i>eu</i> , corresponding sound short or medium, as in Fr. <i>peu</i> =Ger. <i>ö</i> short.
a, as in <i>fat</i> .	ō, as in <i>note</i> , <i>moan</i> .
â, as in <i>fall</i> .	o, as in <i>not</i> , <i>soft</i> —that is, short or medium.
a, obscure, as in <i>rural</i> , similar to <i>u</i> in <i>but</i> , é in <i>her</i> : common in Indian names.	ö, as in <i>move</i> , <i>two</i> .
ē, as in <i>me</i> = <i>i</i> in <i>machine</i> .	ū, as in <i>tube</i> .
e, as in <i>met</i> .	u, as in <i>tub</i> : similar to é and also to a.
é, as in <i>her</i> .	u, as in <i>bull</i> .
ī, as in <i>pine</i> , or as <i>ei</i> in Ger. <i>mein</i> .	ü, as in Sc. <i>abune</i> =Fr. <i>û</i> as in <i>dû</i> , Ger. <i>ü</i> long as in <i>grün</i> , <i>Bühne</i> .
i, as in <i>pin</i> , also used for the short sound corresponding to ē, as in French and Italian words.	ü, the corresponding short or medium sound, as in Fr. <i>but</i> , Ger. <i>Müller</i> .
	oi, as in <i>oil</i> .
	ou, as in <i>pound</i> ; or as <i>au</i> in Ger. <i>Haus</i> .

Of the *consonants*, b, d, f, h, j, k, l, m, n, ng, p, sh, t, v, z, always have their common English sounds, when used to transliterate foreign words. The letter c is not used by itself in re-writing for pronunciation, s or k being respectively used instead. The only consonantal symbols, therefore, that require explanation are the following:—

ch is always as in <i>rich</i> .	s, always as in <i>so</i> .
d, nearly as <i>th</i> in <i>this</i> =Sp. <i>d</i> in <i>Madrid</i> , &c.	th, as <i>th</i> in <i>thin</i> .
g is always hard, as in <i>go</i> .	th, as <i>th</i> in <i>this</i> .
h represents the guttural in Scotch <i>loch</i> , Ger. <i>nach</i> , also other similar gutturals.	w always consonantal, as in <i>we</i> .
n, Fr. nasal <i>n</i> as in <i>bon</i> .	x=ks, which are used instead.
r represents both English <i>r</i> , and <i>r</i> in foreign words, which is generally much more strongly trilled.	y always consonantal, as in <i>yea</i> (Fr. <i>ligne</i> would be re-written <i>lëny</i> ).
	zh, as <i>s</i> in <i>pleasure</i> =Fr. <i>j</i> .

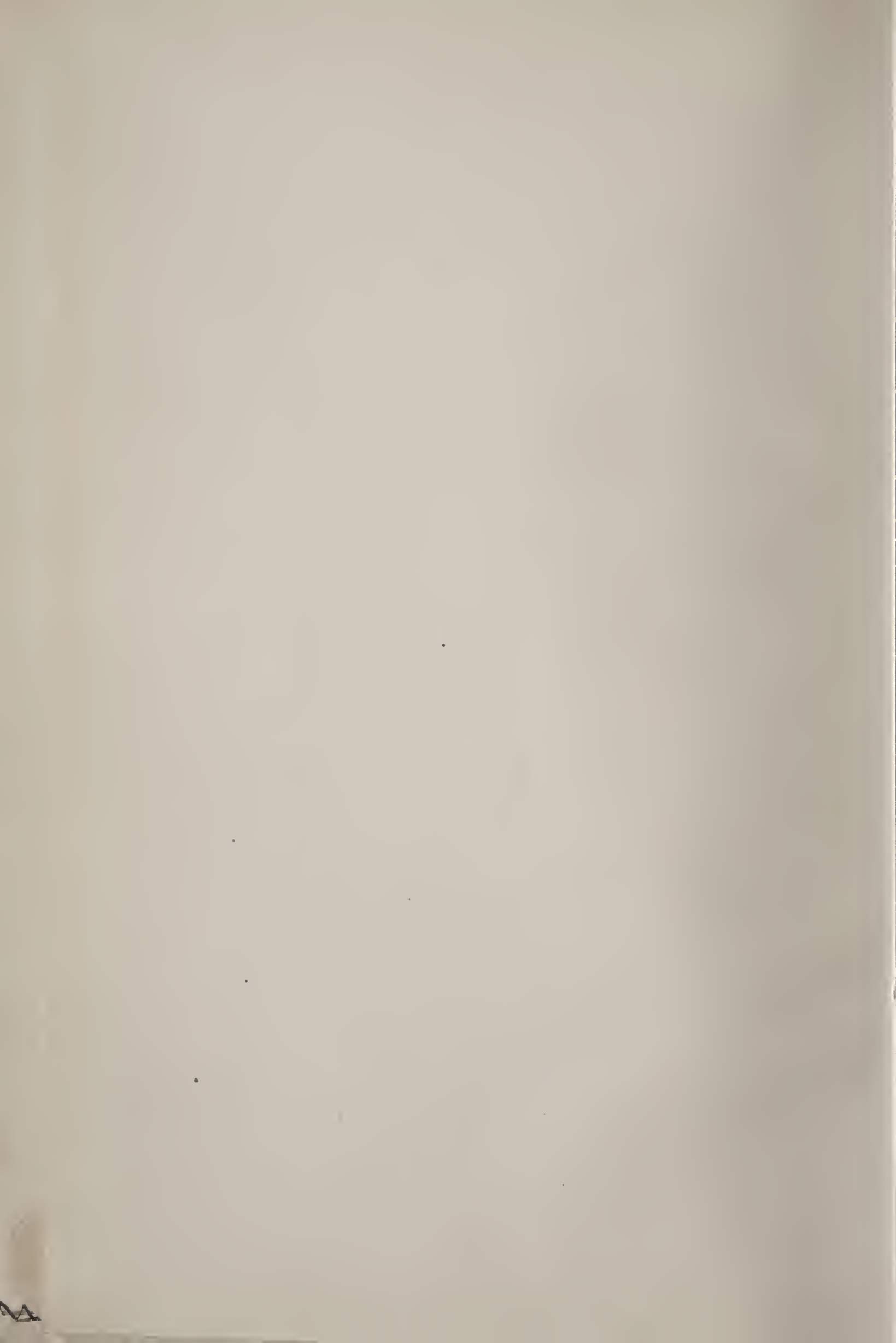

# THE NEW CABINET CYCLOPÆDIA.

---

## VOL. II.

---

**Black-quarter**, a kind of apoplectic disease which attacks cattle, indicated by lameness of the fore-foot, one of the limbs swelling, and after death being suffused with black blood, which also is found throughout the body.

**Black-rock**, town of Ireland, on Dublin Bay, about 5 miles from the capital; sea-bathing and residential locality. Pop. 8380.

**Black-rod**, in England, the usher belonging to the order of the Garter, so called from the black rod which he carries. His full title is Gentleman-usher of the Black Rod, and his deputy is styled the Yeoman-usher. They are the official messengers of the House of Lords; and either the gentleman- or the yeoman-usher summons the Commons to the House of Lords when the royal assent is given to bills; and also executes orders for the commitment of parties guilty of breach of privilege and contempt.

**Black Sea** (ancient *Pontus Euxinus*), a sea situated between Europe and Asia, and mainly bounded by the Russian and Turkish dominions, being connected with the Mediterranean by the Bosphorus, Sea of Marmora, and Dardanelles, and by the Strait of Kertsch with the Sea of Azov, which is, in fact, only a bay of the Black Sea; area of the Black Sea and the Sea of Azov about 175,000 square miles, with a depth in the centre of more than 150 fathoms and few shoals along its shores. The water is not so clear as that of the Mediterranean, and is less salt on account of the many large rivers which fall into it—the Danube, Dniester, Dnieper, Don, &c. Though not tidal, there are strong currents. The tempests on it are very violent, as the land which confines its agitated waters gives to them a kind of whirling motion, and in the winter it is scarcely navigable. During January and February the shores from

Odessa to the Crimea are ice-bound. It contains few islands, and those of small extent. The most important ports are those of Odessa, Kherson, Eupatoria, Sebastopol, Batum, Trebizond, Samsun, Sinope, and Varna. The fisheries are of some value. After the capture of Constantinople the Turks excluded all but their own ships from the Black Sea until 1774, when, by the Treaty of Kainarji, they ceded to Russia the right also to trade in it. The same right was accorded to Austria in 1784, and by the Peace of Amiens to Britain and France in 1802. The preponderance thereafter gained by Russia was one of the causes of the Crimean war, in which she was compelled to cede her right to keep armed vessels in it, the sea being declared neutral by the Treaty of Paris, 1856. In 1871, however, when France could not attend, owing to the Franco-German war, the sea was deneutralized by a conference of the European powers at London in response to the Russian protest.

**Black-snake** (*Coluber constrictor*), a common snake in North America, reaching a length of 5 or 6 feet, and so agile and swift as to have been named the *Racer*, with no poison fangs, and therefore comparatively harmless. It feeds on small quadrupeds, birds, and the like, and is especially useful in killing rats.

**Blackstone**, SIR WILLIAM, an eminent jurist, born in London in 1723; educated at the Charter House and Pembroke College, Oxford. In 1743 he was elected fellow of All-Souls College, Oxford, and in 1746 was called to the bar; but, having attended the Westminster law-courts for seven years without success, he retired to Oxford. Here he gave lectures on law, which suggested to Mr. Viner the idea of founding a professorship at Oxford for the study of the common law; and Blackstone was in 1758 chosen

the first Vinerian professor. In 1759 he published a new edition of the Great Charter and Charter of the Forest; and during the same year resumed his attendance at Westminster Hall with abundant success. In 1761 he was elected M.P. for Hindon, made king's counsel and solicitor-general to the queen. He was also appointed principal of New Inn Hall; which office, with the Vinerian professorship, he soon resigned. In 1765 he published the first volume of his famous Commentaries on the Laws of England, the other three volumes being produced at intervals during the next four years. Its merits as an exposition made it for a long period the principal text-book of English law. He died in 1780.

**Blackstone**, Worcester county, Mass., a thriving manufacturing town, 26 miles S. E. of Worcester; has 7 churches, a bank and public library. Pop. in 1890, 6137.

**Black-thorn.** See *Sloe*.

**Black Tin**, tin ore when dressed, stamped, and washed ready for smelting, forming a black powder.

**Black Vomit**, the dark substance thrown up in yellow fever: hence a name of this disease.

**Black Wadd**, an ore of manganese, used as a drying ingredient in paints.

**Black Watch.** See *Highland Regiments*.

**Blackwell**, ELIZABETH, the first woman who ever obtained the degree of M.D. She was born in England in 1821, and settled in America with her parents in 1831, where from 1838 to 1847 she was engaged in teaching. After numerous difficulties she was admitted into the College of Geneva, N. Y., and graduated M.D. in 1849. She afterwards studied in Paris, and commenced practice in New York in 1851, where she has since chiefly resided. In 1854, with her sister Emily, she opened an hospital for women and children in New York.

**Black-wood**, or INDIAN ROSEWOOD, a leguminous tree of Hindustan (*Dalbergia latifolia*), the timber of which is highly valued and much used in the manufacture of fine furniture. The Australian Black-wood is the *Acacia melanoxylon*.

**Black'wood**, WILLIAM, an Edinburgh publisher, born at Edinburgh 1776, died 1834. He started as a bookseller in 1804, and soon became also a publisher. The first number of Blackwood's Magazine appeared 1st of April, 1817, and it has always been conducted in the Tory interest. He secured as contributors most of the leading writers

belonging to the Tory party, among them Sir Walter Scott, Lockhart, Hogg, Professor Wilson, De Quincey, Dr. Moir (Delta), Thomas Aird, Dr. Maginn, John Galt, and others. The work of editor he performed himself. After his death the business, which has developed into a large publishing concern, was carried on by his sons, and the magazine still keeps its place among the leading periodicals. More recent contributors to it were Bulwer-Lytton, Professor Aytoun, Landor, Charles Lever, Sir Archibald Alison, Sir Theodore Martin, Mrs. Oliphant, W. W. Story, Frederick Locker, Lord Neaves, George Henry Lewes, and George Eliot.

**Blackwood's Magazine.** See *Blackwood*.

**Bladder**, URINARY, a musculo-membranous bag or pouch present in all mammalia, destined to receive and retain for a time the urine which is secreted by the kidneys. It occupies the anterior and median portion of the pelvis, and in the male of the human subject is situated behind the pubis and above and in front of the rectum; in the female above and in front of the vagina and uterus. The urine secreted by the kidneys is conveyed into this reservoir by means of two tubes called the ureters, which open near the neck or lower part of the bladder in an oblique direction, by which means they prevent the reflux of the urine. When empty it forms a rounded, slightly conoid mass about the size of a small hen's egg. As it gradually fills with urine its walls become distended in all directions except in front, and it then rises above the pelvis proper into the abdomen. It is held in its place by two lateral ligaments, one on each side, and an anterior ligament. The contents are carried off by the urethra, which, as well as the neck of the bladder, is surrounded by a structure called the prostate gland.

**Bladder-fern.** See *Cystopteris*.

**Bladder-nut**, a name of shrubs or small trees of the genus *Staphylēa*, order Sapindaceæ, natives of Europe, Asia, and North America, the fruits of which consist of an inflated bladderly capsule containing the seeds.

**Bladderwort**, the common name of slender aquatic plants, genus *Utricularia*, order Lentibulariaceæ, species of which are natives of Britain, the United States, &c., growing in ditches and pools. They are named from having little bladders or vesicles, that fill with air at the time of flowering and raise



the plant in the water, so that the blossoms expand above the surface.

**Bladder-wrack** (*Fucus vesiculōsus*), a sea-weed so named from the floating vesicles in its fronds.

**Bladud'**, in legendary British history, the father of King Lear. He is said to have been the founder of the city of Bath, having been cured of his leprosy by its medicinal waters.

**Blaeu**, **BLAEUW**, or **BLAUW** (blä'u), a Dutch family celebrated as publishers of maps and books. William (1571–1638) established the business at Amsterdam, constructed celestial and terrestrial globes, and published *Novus Atlas* (6 vols.), an excellent work, and *Theatrum Urbium et Munimentorum*. His son John (died 1673) published the *Atlas Magnus* (11 vols.), and various topographical plates and views of towns. The works of this family are still highly valued.

**Blagovieshtchensk** (blä-go-vyes'chensk), a Russian town of Eastern Siberia, for a time capital of the province of the Amoor, on the Amoor and Dzega rivers, near the Chinese town of Aigoon. Pop. 3800.

**Blaine**, **JAMES GILLESPIE**, American statesman, born 1830. He entered Washington College, Pa., at the age of thirteen, graduated in 1847, studied law, acted as a teacher, and then having gone to Augusta, Maine, was for several years newspaper editor. He was sent to Congress by Maine as a republican in 1862, and was repeatedly re-elected. Soon becoming prominent he was several times speaker of the House of Representatives. In 1876 he entered the Senate, and the same year he was second in his candidature for presidential nomination by the republican national convention; he was also unsuccessful in his candidature in 1880; but in 1884 he was nominated by a large majority, though the presidency went to Mr. Cleveland. In 1888 though again a candidate for nomination he was defeated. In 1884 appeared the first volume of his *Twenty Years of Congress*, a work which has had a very favourable reception. He was Secretary of State from 1889 to 1892. He died Jan. 27, 1893.

**Blainville** (blā-vēl), **HENRI MARIE DUCROTAY DE**, French naturalist, born 1777, died 1850. After attending a military school, and also studying art, his interest in Cuvier's lectures led him to the study of medicine and natural history. Cuvier chose him for his assistant in the College of France and

the museum of natural history, and in 1812 secured for him the chair of anatomy and zoology in the Faculty of Sciences at Paris. In 1825 he was admitted to the Academy of Sciences; in 1829 he became professor in the Museum of Natural History, lecturing on the mollusca, zoophytes, and worms; and in 1832 he succeeded Cuvier in the chair of comparative anatomy there. His chief works are *L'Organisation des Animaux ou Principes d'Anatomie Comparée* (1822); *Manuel de Malacologie et de Conchyliologie* (1825); *Cours de Physiologie Générale* (1829–32); *Manuel d'Actinologie* (1834); *Ostéographie*, a work on the vertebrate skeleton.

**Blair**, **HUGH**, D.D., Scottish divine and author, born at Edinburgh 1718, died 1800. He was minister successively of Collessie in Fifeshire, Canongate Church, Edinburgh, Lady Yester's Church, and the High Church. In 1762 he was made professor of rhetoric and belles-lettres in the University of Edinburgh, being the first that ever occupied this chair. He is author of a *Dissertation on the Poems of Ossian*; *Lectures on Rhetoric and Belles Lettres*; and *Sermons*, which were long greatly esteemed, and which, attracting the attention of George III., procured for the author a pension of £200 a year.

**Blair**, **ROBERT**, author of *The Grave*, born in Edinburgh 1699; died 1746. He was ordained in 1731 minister of Athelstaneford, where he spent the remainder of his life. His *Grave* was first printed in 1743, and is now esteemed as one of the standard classics of English poetical literature. His third son, Robert (1741–1811), rose to be president of the Court of Session.

**Blair-Ath'ole**, a village of Scotland, Perthshire, 30 miles N.N.W. from Perth. Near it is Blair Castle, the seat of the Duke of Athole.

**Blairgow'rie**, a town in Perthshire, Scotland, on the Erich,  $4\frac{1}{2}$  miles N.W. of Cupar-Angus, with flourishing linen manufactures. Pop. 3950.

**Blake**, **EDWARD**, Canadian lawyer and statesman, born in 1833. He was educated at Toronto, graduating from University College in 1857. He was called to the bar in 1859, and speedily gained a high position in his profession. In 1867 he became a member of the Ontario, as well as of the Canadian, parliament, and in the former took the position of leader of the liberal opposition. On his party coming into power in 1871 he became premier of the

## BLAKE.

Ontario legislature, but after one session resigned. In 1873 he became a member of the Canadian cabinet, and soon after president of the council and minister of justice under the Mackenzie administration, which however had to go out of office as a result of the election of 1878. Mr. Blake was out of parliament for one session, but on his return to it he was chosen leader of the liberal party in place of Mr. Mackenzie (1880). As such he has had Sir J. A. Macdonald as his chief opponent. He is one of the ablest speakers in the Dominion.

**Blake, ROBERT**, a celebrated British admiral, was born at Bridgewater in 1599, died at the entrance of Plymouth Sound 1657. On finishing his education at Oxford he lived for some time in a private manner on the fortune left him by his father. He was elected member for Bridgewater in the parliament of 1640. This being soon dissolved he lost his election for the next, and sought to advance the parliamentary cause in a military capacity in the war which then broke out. He soon distinguished himself, and in 1649 he was sent to command the fleet with Colonels Deane and Popham. He attempted to block up Prince Rupert in Kinsale, but the prince, contriving to get



Admiral Blake.

his fleet out, escaped to Lisbon, where Blake followed him. Being refused permission to attack him in the Tagus by the King of Portugal, he took several rich prizes from the Portuguese, and followed Rupert to Malaga, where, without asking permission of Spain, he attacked him and nearly de-

stroyed the whole of his fleet. His greatest achievements were, however, in the Dutch war which broke out in 1652. On the 19th of May he was attacked in the Downs by Van Tromp with a fleet of forty-five sail, the force of Blake amounting only to twenty-three, but Van Tromp was obliged to retreat. On May 29 he was again attacked by Van Tromp, whose fleet was now increased to eighty sail. Blake had a very inferior force, and after every possible exertion was obliged to retreat into the Thames. In February following he put to sea with sixty sail, and soon after met the Dutch admiral, who had seventy sail and 300 merchantmen under convoy. During three days a running fight up the Channel was maintained with obstinate valour on both sides, the result of which was the loss of eleven men-of-war and thirty merchant ships by the Dutch, while that of the English was only one man-of-war. In this action Blake was severely wounded. On June 3 he again engaged Van Tromp and forced the Dutch to retire with considerable loss into their own harbours. In November 1654 he was sent with a strong fleet to enforce a due respect to the British flag in the Mediterranean. He sailed first to Algiers, which submitted, and then demolished the castles of Goletta and Porto Ferrino, at Tunis, because the dey refused to deliver up the British captives. A squadron of his ships also blocked up Cadiz, and intercepted a Spanish Plate fleet. In April, 1657, he sailed with twenty-four ships to Santa Cruz, in Teneriffe; and notwithstanding the strength of the place, burned the ships of another Spanish Plate fleet which had taken shelter there, and by a fortunate change of wind came out without loss. He died before landing on English soil, and was buried in Westminster Abbey, whence his body was removed at the Restoration and buried in St. Margaret's Churchyard.

**Blake, WILLIAM**, mystic artist and poet, author of many exquisite lyrics, and of designs mainly allegorical or symbolical, was the son of a London hosier, and was born in 1757. He was apprenticed to an engraver at the age of fourteen. After completing his apprenticeship he was for a short time a student in the Royal Academy, and for years supported himself mainly by engraving for the booksellers. In 1782 he married Catherine Boucher, who proved an invaluable help to him in his work. Next year he published *Poetical Sketches* in the ordinary way and without illustrations.

Failing to find a publisher for his next work *Songs of Innocence*, he invented a process by which he was both printer and illustrator of his own poems. He engraved upon copper both the text of his poems and the surrounding decorative design, and to the pages printed from the plates an appropriate colouring was afterwards added by hand. In this way the whole of his future work was produced. Some of his other best-known works are: *Gates of Paradise*, *Book of Thel*, *Marriage of Heaven and Hell*, *Songs of Experience*, *Book of Urizen*, *Song of Los*, *Book of Ahania*, &c. He also illustrated *Young's Night Thoughts*, *Blair's Grave*, and *The Book of Job*. The distinguishing feature of his genius was the faculty of seeing the creations of his imagination with such vividness that they were as real to him as objects of sense. He died in 1828. *Lives of Blake* have been written by Alex. Gilchrist (1863) and William Rossetti (1874); and a critical essay on his life and works by Mr. Swinburne was published in 1868. His complete poetical works were collected in 1874, and a volume of etchings from his works, with descriptive text by W.B. Scott, was published in 1878.

**Blanc** (blän), AUGUSTE ALEXANDRE PHILIPPE CHARLES, younger brother of Louis Blanc, born 1815, died 1882. An eminent art-critic, he was elected a member of the French Academy in 1878, and filled the chair of æsthetics and art-history in the Collège de France. He wrote *Grammaire des Arts au Dessin*, *L'Art dans la Parure*, *Observations sur les Arts Egyptien et Arabe*, &c.

**Blanc** (blän), JEAN JOSEPH LOUIS, French historian, publicist, and politician, born at Madrid 1813, died at Paris 1882. He was educated at Rhodéz and Paris, and early devoted himself to the career of journalism. In 1839 he founded the *Revue du Progrès*, in which first appeared his *De l'Organisation du Travail*. In 1841-44 appeared his *Histoire de Dix Ans: 1830-1840*. On the outbreak of the revolution of 1848 Blanc was elected a member of the provisional government, and appointed president for the discussion of the labour question. After the closing of the *Ateliers Nationaux*, a scheme which he strenuously opposed, and the June insurrection of 1848, he was prosecuted for conspiracy, but escaped to England. During his residence there he wrote the bulk of his *Histoire de la Révolution Française*. His other works of note are:

*Lettres sur l'Angleterre* (1865-67), *Histoire de la Révolution de 1848* (1870), *Questions d'Aujourd'hui et de Demain* (1873-74). On the downfall of the Second Empire Blanc returned to Paris, and became a member of the National Assembly.

**Blanc**, MONT. See *Mont Blanc*.

**Blanchard** (blän-shär), FRANÇOIS, French aeronaut, born 1753, died 1809. In 1785 he crossed the Channel in a balloon, for which feat he received a pension from the French king. He made many remarkable ascents in various parts of the world. His wife, born 1778, was his companion in many of his voyages, and was killed by her balloon taking fire, 1819.

**Blanchard** (blän'shär), LAMAN, English miscellaneous writer, born in 1803, died 1845. In 1828 he published a volume of poetry, entitled *Lyrical Offerings*. In 1831 he became editor of the *Monthly Magazine*, and was afterwards connected with several magazines and newspapers. The death of his wife affected him so deeply that in a moment of temporary insanity he committed suicide. His tales and essays, entitled *Sketches from Life*, were published with a memoir by Lord Lytton in 1849; his poetical works in 1876.

**Blanche of Castile**, daughter of Alphonso IX., queen of Louis VIII., king of France, and mother of St. Louis, born 1187, died 1252 or 1253. On the death of Louis VIII. she procured the coronation of her son, and during his minority held the reins of government in his name with distinguished success. In 1244, when St. Louis left for the Holy Land, she again became regent, and gave new proofs of her abilities and firmness as a ruler.

**Blanch-holding**, a mode of tenure not unfrequent in Scotland by which the tenant is bound to pay only a nominal, or trifling, yearly duty to his superior, as an acknowledgment of his right, and only if demanded.

**Blanching**. See *Etiolation*.

**Blanc-mange** (blé-mänzh'), in cookery, a name of different preparations of the consistency of a jelly, variously composed of dissolved isinglass, arrow-root, maize-flour, &c., with milk and flavouring substances.

**Bland**, RICHARD P., Congressman, born near Hartford, Ky., Aug. 19, 1835; practised law in California and Nevada; has been member of Congress from Missouri since 1874. He is author of *Bland silver bill*, passed in 1878; and an advocate of free coinage of silver and of tariff reform

**Blane**, SIR GILBERT, Scottish physician, born in Ayrshire 1749, died 1834. He was educated at Edinburgh University, but took the degree of M.D. at Glasgow. He became private physician to Admiral Rodney, and then physician to the fleet in the W. Indies, in which position he introduced the use of lime-juice and other means of preventing scurvy into the navy. In 1783–95 he was physician in St. Thomas's Hospital. He was physician-in-ordinary to George IV. both before and after he became king. His chief publication is *Elements of Medical Logic*.

**Blan'kenberghe** (-berg), a much-frequented sea-side resort on the coast of Belgium.

**Blan'kenburg**, a town of Germany, duchy of Brunswick, on the northern slope of the Hartz Mountains, a favourite resort of tourists. On the summit of a height is the ducal palace. Pop. 5117.

**Blan'kenese** (-nā-ze), a town on the right bank of the Elbe, 5 miles w. of Altona; a pleasure-resort of the Altonese and Hamburgers. Pop. 4000.

**Blank Verse**, verse without rhyme, first introduced into English poetry (from the Italian) by the Earl of Surrey, who was beheaded in 1547. The most common form of English blank verse is the decasyllabic, such as that of Milton's *Paradise Lost*, or of the dramas of Shakspeare. From Shakspeare's time it has been the kind of verse almost universally used by dramatic writers, who often employ an additional syllable, making the lines not strictly decasyllabic. The first use of the term blank verse is said to be in *Hamlet*, ii. 2: 'The lady shall say her mind freely, or the blank verse shall halt for't.' The term is not applied to the Anglo-Saxon and Early English alliterative unrhymed verse.

**Blanqui** (blān-kē), JEROME ADOLPHE, French economist, born at Nice 1798, died at Paris 1854. While studying medicine at Paris he made acquaintance with Jean Baptiste Say, and was induced to devote himself to the study of economics. He succeeded Say in the *Conservatoire des Arts et Métiers* as professor of industrial economy. Blanqui, who favoured a free-trade policy, published, among other works, *Précis Élémentaire d'Économie Politique* and *Histoire de l'Économie Politique en Europe*. —LOUIS AUGUSTE, his brother, born 1805, died 1881, was early engaged as a socialistic revolutionist and conspirator, and spent

much of his life in prison for his extreme opinions and actions.

**Blantyre** (-tīr'), a populous mining parish in Lanarkshire, Scotland, containing several villages, at one of which Dr. Livingstone was born. Pop. 9760. This parish has given its name to an African mission station founded in 1876 by the Established Church of Scotland, on the heights which rise between the Upper Shiré river and Lake Shirwa, about lat. 15° s., lon. 35° e., now the centre of settlement and trade.

**Blap'sidæ**, a family of nocturnal black beetles, whose wings are generally obsolete and their elytra soldered together. They frequent gloomy damp places, and when seized discharge, in self-defence, a liquid of a peculiar penetrating odour. *Blaps mortisāga*, or church-yard beetle, is the most familiar British specimen.

**Blar'ney**, a village, Ireland, 4 miles n.w. of the city of Cork, with Blarney Castle in its vicinity. A stone called the *Blarney Stone*, near the top of the castle, is said to confer on those who kiss it the peculiar kind of persuasive eloquence alleged to be characteristic of the natives of Ireland. The 'groves of Blarney' are extensive and interesting, and beneath the castle there are also some curious natural caves.

**Bla'sius**, St., Bishop of Sebaste, in Armenia, is said to have suffered martyrdom about 316. He is said to have been tortured with a wool-comb, hence he is claimed as the patron-saint of the wool-combers.

**Blas'phemy** is the denying of the existence of God, assigning to him false attributes, or denying his true attributes; contumelious reproaches of our Saviour; profane scoffing at the Holy Scriptures, or exposing them to ridicule and contempt. In Catholic countries it also includes the speaking contemptuously or disrespectfully of the Holy Virgin or the saints. By the common law of England blasphemies of God, as denying his being and providence, all contumelious reproaches of Jesus Christ, &c., are punishable by fine and imprisonment, or corporal punishment. In a case decided in 1883 it was held that a person may attack the fundamentals of religion without being guilty of a blasphemous libel 'if the decencies of controversy are observed.' In the United States, besides the common law, there are many statutes defining blasphemy; but they all hold it to consist in words regarding the Deity only. It is a misdemeanour at common law.

## BLAST — BLASTING.

**Blast, Hot.** See *Blast-furnace*.

**Blast-furnace**, the name given to the common smelting-furnace used for obtaining iron from its ores with the aid of a powerful blast of air. This air-blast, which is propelled by a powerful blowing-engine and is now invariably heated to a high temperature (600° to 900° F.), is injected by pipes called tuyeres, situated as shown at A in the annexed vertical section, in the lowest part of the furnace, near to the hearth B.

The conical part C next above the hearth is termed the boshes, and the interior is continued upwards, sometimes, as in the annexed cut, in a tapered body or cone D, sometimes as a perpendicular cylinder, which is surmounted by an opening for the introduction of the materials from an external gallery F. The exterior consists of massive masonry of stone or firebrick, the body part being



Section of Blast-furnace

lined with two shells of firebricks separated by a thin space to allow for expansion, this space being generally filled with sand, ground fire-clay, or the like, to hinder the radiation of heat to the outside. When the body rises in the form of a perpendicular cylinder it is called the barrel. The cone or barrel is sometimes clasped round on the outside by numerous strong iron hoops, or is cased with iron plates fastened to the masonry by iron bolts. The boshes C are lined with firebrick or firestone, and the hearth B is built with large blocks of refractory stone. The charging of the furnace goes on all day and night, one charge consisting of a barrow-load of coal and a barrow-load of ore, char, and lime, the last mineral acting as a flux. These charges are constantly passing downwards and undergoing a change as they come nearer the hotter parts of the furnace. Towards the lower part the earthy matter of the ore unites with the limestone and forms a slag, which finally escapes at an opening below the tuyeres, and the molten metal drops

down and fills the lower part at B, to be drawn off at stated periods. This is done usually twice in the twenty-four hours by means of a round hole called a tap. The furnace is constantly kept filled to within about 2 feet of the top. The ore put in at the top takes about thirty-six hours before it comes out as iron. Hematite yields on an average about 55 per cent of metal, and blackband about 40 to 50. In the newer forms of furnaces the top is closed, and the gases formerly burned at the top are conveyed by pipes G to be utilized as fuel in heating the blast and in raising steam for the blowing-engine. The principle adopted is to close the top by a bell-and-cone arrangement E, which is opened and shut at pleasure by hydraulic or other machinery. The height of furnaces varies from 50 to 80, and even in some cases to upwards of 100 feet, and the greatest width is about one-third of this.

**Blasting**, the operation of breaking up masses of stone or rock *in situ* by means of gunpowder or other explosive. In ordinary operations holes are bored into the rock of from 1 to 6 inches in diameter, by means of a steel-pointed drill, by striking it with hammers or allowing it to fall from a height. After the hole is bored to the requisite depth it is cleaned out, the explosive is introduced, the hole is 'tamped' or filled up with broken stone, clay, or sand, and the charge exploded by means of a fuse or by electricity. In larger operations mines or shafts of considerable diameter take the place of the holes above described. Shafts are sunk from the top of the rock to various depths, sometimes upwards of 60 feet. This shaft joins a heading, or gallery, driven in from the face, if possible along a natural joint; and from this point other galleries are driven some distance in various directions, with headings at intervals, returning towards the face of the rock and terminating in chambers for the charges. Enormous charges are frequently made use of, upwards of twenty tons of gunpowder having been fired in a single blast. One of the greatest blasting operations ever attempted was the removal of the reefs in the East River, near New York, known as Hellgate. An entrance-shaft was sunk on the Long Island shore, from which the reef projected. From this shaft nearly twenty tunnels were bored in all directions, extending from 200 to 240 feet, and connected by lateral galleries. Upwards of 52,000 lbs. of dynamite, rend-rock, and

powder were used, and millions of tons of rock were dislodged. Numerous important improvements have been made in blasting by the substitution of rock-boring machines for hand labour. Of such machines, in which the 'jumper' or drill is repeatedly driven against the rock by compressed air or steam, being also made to rotate slightly at each blow, there are many varieties.

**Blas'toderm**, in biol. the germinal skin or membrane forming the superficial layer of the impregnated ovum, and from which the rudiment of the new being is formed.

**Blastogen'esis**, in biol. reproduction by gemmation or budding.

**Blastoi'dea**, an order of fossil Echinodermata, closely allied to the Crinoidea. The body was inclosed in a kind of box, formed by jointed calcareous plates, and was, in most cases, permanently fixed to the seabottom by a stalk or column.

**Blas'tomere**, in biol. the term applied to each segment into which the ovum divides after impregnation. The segments may remain united as a single cell aggregate, or some or all of them may become separate organisms.

**Blat'tidæ**, a family of insects of the order Orthoptera. They are extremely voracious, some species apparently eating almost everything that comes in their way. The type of the family is the well-known cockroach (*Blatta orientālis*).

**Blaye** (blā), a fortified port of France on the Gironde, covering with other forts the approach to Bordeaux. Pop. 4000.

**Bla'zonry**, in heraldry, the art of describing coats-of-arms in proper technical terms and method.

**Bleaching**, the act or art of freeing textile fibres and fabrics and various other substances (such as materials for paper, ivory, wax, oils) from their natural colour, and rendering them perfectly white, or nearly so. The ancient method of bleaching by exposing the fabrics, &c., to the action of the sun's rays, and frequently wetting them, has been nearly superseded, at least where the business is carried on on the large scale, more complicated processes in connection with powerful chemical preparations being now employed. Among the latter the chief are chlorine and sulphurous acid, the latter being employed more especially in the case of animal fibres (silk and wool), while cotton, flax, and other vegetable fibres are operated upon with chlorine, the bleaching in both cases being preceded by certain clean-

ing processes. The use of chlorine as a bleaching agent was first proposed by Berthollet in 1786, and shortly afterwards introduced into Great Britain, where it was first used simply dissolved in water, afterwards dissolved in alkali, and then in the form of bleaching-powder, commonly called chloride of lime, the manufacture of which was patented by Mr. Tennant of St. Rollox, Glasgow, in 1799. In modern calico bleaching the preliminary process is *singeing* by passing the fabric over red-hot plates or through a gas-flame to remove the downy pile and short threads from the surface of the cloth. The goods next pass to the *liming* process, when they are uniformly and thoroughly impregnated with a supersaturated solution of lime. The next process is the *bowking* or boiling for several hours, after which they are washed. They are then *soured* by being passed through a solution of hydrochloric acid for the purpose of dissolving any traces of free lime which may have been left in the washing, and to decompose the calcareous soap formed by the bowking process. After boiling in kiers with a solution of soda-ash and rosin and another washing, the cloth is ready for the processes of *chemicking* or liquoring with bleaching-powder, and *white-souring* with a very dilute sulphuric acid. Another thorough washing concludes the operations of bleaching proper, after which the cloth goes through various finishing processes. Modifications of the same processes are adopted in bleaching linen, wool, silk, &c.

**Bleaching-powder**, chloride of lime made by exposing slaked lime to the action of chlorine. It is regarded as a double salt of the chloride of calcium and hypochlorite of calcium. It is much used as a disinfectant, besides its use in bleaching.

**Bleak**, a small river fish, 6 or 7 inches long, the *Leuciscus alburnus*, of the Carp family. It somewhat resembles the dace, and is found in many European and British rivers. Its back is greenish, otherwise it is of a silvery colour, and its silvery scales are used in the manufacture of artificial pearls. It is good eating.

**Bleeding**. See *Hemorrhage* and *Phlebotomy*.

**Bleek** (blāk), FRIEDRICH, German biblical scholar and critic, born 1793, died 1859. He was appointed professor of theology at Bonn 1829. He was the author of expository books, Introductions to the Old and New Testaments (1860-62), &c.

**Bleek**, WILHELM HEINRICH IMMANUEL, son of the above, an able linguist, especially in the South African languages, born in Berlin 1827, died at Cape Town 1875. In 1855 he went to South Africa and devoted himself to the study of the language, manners, and customs of the natives. In 1860 he was appointed public librarian at Cape Town, and his researches were rewarded with a pension from the civil list. He was principal author of the Handbook of African, Australian, and Polynesian Philology, 1858-63, his other chief productions being Vocabulary of the Mozambique Languages, 1856; Comparative Grammar of South African Languages, 1862; Hottentot Fables and Tales, 1864; and The Origin of Language, 1868.

**Blende** (blend), an ore of zinc, called also *Mock-lead*, *False Galena*, and *Black-jack*. Its colour is mostly yellow, brown, and black. There are several varieties, but in general this ore contains more than half its weight of zinc, about one-fourth sulphur, and usually a small portion of iron. It is a native sulphide of zinc.

**Blenheim** (blen'im; Ger. blen'him), a village in Bavaria on the Danube. Near it was fought, August 13, 1704, during the war of the Spanish succession, the famous battle of Blenheim (or *Höchstädt*, from another village in the vicinity), in which Marlborough and Prince Eugene, commanding the allied forces of England and Germany (52,000 men), gained a brilliant victory over the French and Bavarians (56,000). The victors lost some 12,000 in killed and wounded; the vanquished 40,000, including prisoners, of whom Villars was one.—The palatial residence of the Dukes of Marlborough at Woodstock, Oxfordshire, was named from this victory. The estate of Woodstock, which belonged to the crown, having been conferred by Queen Anne on the great commander, parliament granted a perpetual pension of £4000 a year, and half a million sterling to erect a suitable family seat. Sir John Vanbrugh was the architect.

**Blenheim Dog**, a variety of spaniel, bearing a close resemblance to the King Charles breed, but somewhat smaller, so named from having been originally bred by one of the Dukes of Marlborough. It has a short muzzle, long silky hair without any curl, and long pendulous ears.

**Blennorrhœ'a**, in med. a copious discharge from a mucous membrane, especially from the urino-genital passages.

**Blenny**, a genus of acanthopterygious fishes (*Blennius*) distinguished by a short rounded head and a long compressed smooth body. Owing to the smallness of their gill openings they can exist for some time without water. Several species frequent the British coasts, as the *B. Montagu*, or Montagu's blenny; *B. ocellaris*, the ocellated blenny or butterfly-fish; *B. pholis*, the shanny. Many of the genus hatch their young within the body of the female and produce them alive.

**Bléré** (blā-rā), a French town, dep. of Indre-et-Loire, on the Cher, 15 m. E.S.E. of Tours. Pop. 2043. In the vicinity is the Château Chénonceaux, built in the time of Francis I., and still in excellent preservation. It was given by Henry II. to his mistress Diana de Poitiers, who was dispossessed on the death of Henry by Catherine de Medici. In the latter part of the 18th century it was frequented by Fontenelle, Voltaire, Rousseau, and all the wits of the time, who were drawn together by the then owner of the château, Madame Dupin, widow of a fermier général who died in 1799.

**Blesbok** (*Alceläphus albifrons*), an antelope of South Africa with a white marked face, a general purplish-chocolate colour, and a 'saddle' of a bluish colour; found in great numbers in the Transvaal and Orange Free State and much hunted.

**Blessed Thistle** (*Cnicus benedictus*), a native of the south of Europe, formerly in great repute as a medicinal plant.

**Blessing**, or BENEDICTION, a prayer or solemn wish imploring happiness upon another; a certain holy action which, combined with prayer, seeks for God's grace for persons, and, in a lower degree, a blessing upon things, with a view whether to their efficiency or safety. The lifting up of the hands is an inseparable adjunct of the act of blessing. In the Rom. Cath. Church the sign of the cross is made, and the thumb and the two first fingers of the right hand are extended, the two remaining fingers turned down. In the Greek Church the thumb and the third finger of the same hand are conjoined, the other fingers being stretched out. Some see in this position a representation of the sacred monogram in Greek letters of our Lord's name.—In the English liturgy there are two blessings or benedictions; in the service of the Scotch Church there is only one.

**Blessington**, MARGARET, COUNTESS OF, was born near Clonmel, Ireland, 1789, died

at Paris 1849. She was the daughter of Mr. Edmund Power, an improvident man of good family, and at the age of fifteen was married to a Captain Farmer, who died in 1817; and a few months after his death his widow married Charles John Gardiner, earl of Blessington. In 1822 they went abroad, and continued to reside on the Continent till the earl's death in 1829, when Lady Blessington took up her abode in Gore House, Kensington. Her residence became the fashionable resort for all the celebrities of the time; and that notwithstanding a doubtful connection which she formed with Count D'Orsay, with whom she lived till her death. She contributed to the *New Monthly Magazine*, *Conversations with Lord Byron*; wrote numerous novels, including *The Belle of a Season*, *The Two Friends*, *Strathern*, and *the Victims of Society*; and acted as editress, for several years, of *Heath's Book of Beauty*, *the Keepsake*, and *the Gems of Beauty*.

**Blicher** (blē'her), STEEN STENSEN, Danish lyrical poet and novelist, born 1782, died 1848. His collected poems, which are national and spirited, were published 1835-36; and his novels, which give admirable pictures of country life in Jutland, in 1846-47. He also translated *Ossian*, and *Goldsmith's Vicar of Wakefield*.

**Blidah** (blē'dä), a fortified town of Algeria, 30 miles inland from Algiers, well-built, with modern houses and public edifices, the centre of a flourishing district, and having a good trade. Pop. 15,255.

**Bligh** (blī), WILLIAM, the commander of the ship *Bounty* when the crew mutinied in the South Seas and carried her off. He was born at Plymouth in 1753, died at London 1817. The *Bounty* had been fitted out for the purpose of procuring plants of the bread-fruit tree, and introducing these into the West Indies. Bligh left Tahiti in 1789, and was proceeding on his voyage for Jamaica when he was seized; and, with eighteen men supposed to be well affected to him, forced into the launch, sparingly provisioned, and cast adrift not far from the island of Tofoa (Tonga Islands), in lat. 19° s. and lon. 184° E. By admirable skill and perseverance, though not without enduring fearful hardships, they managed to reach the island of Timor in forty-one days, after running nearly 4000 miles. Bligh, with twelve of his companions, arrived in England in 1790, while the mutineers settled on Pitcairn Island, where their descendants still exist. Bligh became governor of New South Wales in 1806, but

his harsh and despotic conduct caused him to be deposed and sent back to England. He afterwards rose to the rank of admiral.

**Blight**, a generic name commonly applied to denote the effects of disease or any other circumstance which causes plants to wither or decay. It has been vaguely applied to almost every disease of plants whether caused by the condition of the atmosphere or of the soil, the attacks of insects, parasitic fungi, &c. The term is frequently limited to disease in cereal crops. See *Smut*, *Bunt*, *Ergot*.

**Blim'bing**, the Indian name of the fruit of *Averrhoa Bilimbi*, a small tree, family Oxalidaceæ, called also *Cucumber-tree*, the fruit being acid and resembling a small cucumber. The carambola (which see) belongs to the same genus.

**Blind**, a screen of some sort to prevent too strong a light from shining in at a window, or to keep people from seeing in. *Venetian blinds* are made of slats of wood, so connected as to overlap each other when closed, and to show a series of open spaces for the admission of light and air when in the other position.

**Blind** (blint), KARL, German political agitator and writer on history, mythology, and Germanic literature, born at Mannheim 1820. He was educated at Heidelberg and Bonn, and from his student days till he settled in England in 1852 he was continually engaged in agitating or in heading risings in the cause of German freedom and union. He was frequently imprisoned. The democratic propaganda has since been supported by his pen; and he has written *Fire-burial among our Germanic Forefathers*; *Teutonic Cremation*; *Yggdrasil*, or *The Teutonic Tree of Existence*, &c.

**Blind**, THE, those who want, or are deficient in, the sense of sight. Blindness may vary in degree from the slightest impairment of vision to total loss of sight; it may also be temporary or permanent. It is caused by defect, disease, or injury to the eye, to the optic nerve, or to that part of the brain connected with it. Old age is sometimes accompanied with blindness, occasioned by the drying up of the humours of the eye, or by the opacity of the cornea, the crystalline lens, &c. There are several causes which produce blindness from birth. Sometimes the eyelids adhere to each other, or to the eye-ball itself, or a membrane covers the eyes; sometimes the pupil of the eye is closed, or adheres to the



cornea, or is not situated in the right place, so that the rays of light do not fall in the middle of the eye; besides other defects. (See *Colour Blindness, Hemeralopia, Nyctalopia.*) The blind are often distinguished for a remarkable mental activity, and a wonderful development of the intellectual powers. Their touch and hearing, particularly, become very acute.

As early as 1260 an asylum for the blind (L'hospice des Quinze-Vingts) was founded in Paris by St. Louis for the relief of the Crusaders who lost their sight in Egypt and Syria; but the first institution for the instruction of the blind was the idea of Valentin Haüy, brother of the celebrated mineralogist. In 1784 he opened an institution in which they were instructed not only in appropriate mechanical employments, as spinning, knitting, making ropes or fringes, and working in paste-board, but also in music, in reading, writing, ciphering, geography, and the sciences. For instruction in reading he procured raised letters of metal; for writing he used particular writing-cases, in which a frame, with wires to separate the lines, could be fastened upon the paper; for ciphering there were movable figures of metal, and ciphering-boards in which the figures could be fixed; for teaching geography maps were prepared upon which mountains, rivers, cities, and the boundaries of countries were indicated to the sense of touch in various ways, &c. Similar institutions were soon afterwards founded in Amsterdam, Berlin, Brussels, Copenhagen, Dresden, Edinburgh, Liverpool, London, Vienna, and in many towns of the United States. There are now comparatively few large cities that do not possess a school or institution of some kind for the blind. The occupations in which the blind are found capable of engaging are such as the making of baskets and other kinds of wicker-work, brushmaking, rope and twine making, the making of mats and matting, knitting, netting, fancy work of various kinds, cutting fire-wood, the sewing of sacks and bags, the carving of articles in wood, &c. Piano-tuning is also successfully carried on by some, and the cleaning of clocks and watches has even been occasionally practised by them. In late years an impetus has been given, in Britain, to the higher education of the blind by the formation of the British and Foreign Blind Association, the establishment of a college for the Blind Sons of Gentlemen at Worcester, and the Royal Normal College and Aca-

demy of Music for the Blind, Upper Norwood.

Various systems have been devised for the purpose of teaching the blind to read, some of which consist in the use of the ordinary Roman alphabet, with more or less modification, and some of which employ types quite arbitrary in form. In all systems the characters rise above the surface of the paper so as to be felt by the fingers. The type adopted by Haüy was the script or italic form of the Roman letter. This was introduced into England by Sir C. Lowther, who printed the Gospel of St. Matthew in 1832 with type obtained from Paris. Before this Gall of Edinburgh made use of an embossed alphabet based on the ordinary Roman small letters, in which all curves were replaced by angular lines, and in 1834 he published the Gospel of St. John in this character. Subsequently he introduced various improvements, and in particular the letters were produced with serrated surfaces, thus giving greater distinctness. Alston of Glasgow, Howe of Boston, and others also used the Roman form; but the former (who was the first to print the whole Bible, in 1840) adopted the Roman capitals, while the latter adopted the small letters, printing in this type the Bible and many other books. Of alphabets deviating entirely or nearly so from the Roman letter, one consists of a stenographic shorthand invented by Lucas of Bristol; another is a phonetic shorthand devised by Frere of London. In Dr. Moon's alphabet some of the characters are Roman, others are based on or suggested by the Roman characters. The Braille system is one in which the letters are formed by a combination of dots. Dr. Moon's system from its simplicity and the size of its characters is in very general use in books for the blind. There are also systems by which the blind are enabled to write. The total number of pupils in schools for the blind in the United States in 1889 was 2931; the number of institutions, 33; total expenditure, \$744,763.

**Blind-fish**, the name of several species of fish, family Amblyopsidæ, inhabiting the American cave-streams. They are all small, the largest not exceeding five inches. In the typical species (*Amblyopsis spelæus*) of the Mammoth Cave of Kentucky, the eyes are reduced to a useless rudiment hidden under the skin, the body is translucent and colourless, and the head and body are covered with numerous rows of sensitive

papillæ, which form very delicate organs of touch.

**Blind Harry.** See *Harry the Minstrel*.

**Blind-story.** See *Triforium*.

**Blind-worm,** or SLOW-WORM (*Anguis fragilis*), a reptile, forming a connecting link between the lizards and the snakes, perfectly snake-like in form, having no appearance of external limbs, though the bones of the shoulders and pelvis exist in a rudimentary form; length about a foot, and of nearly equal thickness throughout. Its eyes, though brilliant, are small, and hence its common name. It is common in Great Britain, and is spread over almost the whole of Europe, Western Asia, and Northern Africa. It is perfectless harmless, living upon worms, insects, and snails, and hibernating during the winter. It receives its specific name of *fragilis* from the fact that when frightened it stiffens its muscles to such an extent, and becomes so rigid, that its tail may be snapped off by a slight blow.

**Blister,** a topical application which, when applied to the skin, raises the cuticle in the form of a vesicle, filled with serous fluid, and so produces a counter-irritation. The Spanish fly-blister operates with most certainty and expedition, and is commonly used for this purpose, as well as mustard, hartshorn, &c.

**Blister-beetle,** BLISTER-FLY, the Spanish fly used in making cantharides blisters.

**Blister-steel,** iron bars which, when converted into steel, have their surface covered with blisters, probably from the expansion of minute bubbles of air. Steel is used in the blister state for welding to iron for certain pieces of mechanism, but is not employed for making edge-tools. It requires for this purpose to be converted into cast or shear steel.

**Bliz'zard,** a fierce storm of frosty wind with fine powdery snow, occurring in some parts of N. America and often causing loss of life through suffocation and cold.

**Bloch** (*bloh*), MARCUS ELIEZER, a naturalist of Jewish descent, born at Aispach in 1723, died 1799. His principal work is the *Naturgeschichte der Fische* (Natural History of Fishes), folio, 1785-99, with 432 coloured plates.

**Block,** a mechanical contrivance consisting of one or more grooved pulleys mounted in a casing or shell which is furnished with a hook, eye, or strap by which it may be attached to an object, the function of the apparatus being to transmit power or change

the direction of motion by means of a rope or chain passing round the movable pulleys. Blocks are single, double, treble, or four-fold, according as the number of sheaves or pulleys is one, two, three, or four. A *running block* is attached to the object to be raised or moved; a *standing block* is fixed to some permanent support. Blocks also receive different denominations from their shape, purpose, and mode of application. They are sometimes made of iron as well as of wood. Blocks to which the name of *dead-eyes* has been given, are not pulleys, being unprovided with sheaves.

**Blockade'** is the rendering of intercourse with the seaports of an enemy unlawful on the part of neutrals, and it consists essentially in the presence of a sufficient naval force to make such intercourse difficult. It must be declared or made public, so that neutrals may have notice of it. If a blockade is instituted by a sufficient authority, and maintained by a sufficient force, a neutral is so far affected by it that an attempt to trade with the place invested subjects vessel and cargo to confiscation by the blockading power. The term is also used to describe the state of matters when hostile forces sit down around a place and keep possession of all the means of access to it, so as to entirely cut off its communication with the outside world, and so compel surrender from want of supplies.

**Block-books,** before and for a short time after the invention of printing, books printed from wooden blocks each the size of a page and having the matter to be reproduced, whether text or picture, cut in relief on the surface.

**Block-house,** a fortified edifice of one or more stories, constructed chiefly of blocks



Block-house.

of hewn timber. Block-houses are supplied with loopholes for musketry (*a a*) and sometimes with embrasures for cannon, and when of more than one story the upper ones are

made to overhang those below, and are furnished with machicolations or loopholes in the overhung floor, so that a perpendicular fire can be directed against the enemy in close attack. Block-houses are often of great advantage, and in wooded localities readily constructed.

**Blocksberg**, another name of the Brocken (which see).

**Block-system**, a system of working the traffic on railways according to which the line is divided into sections of 3 or 4 miles,

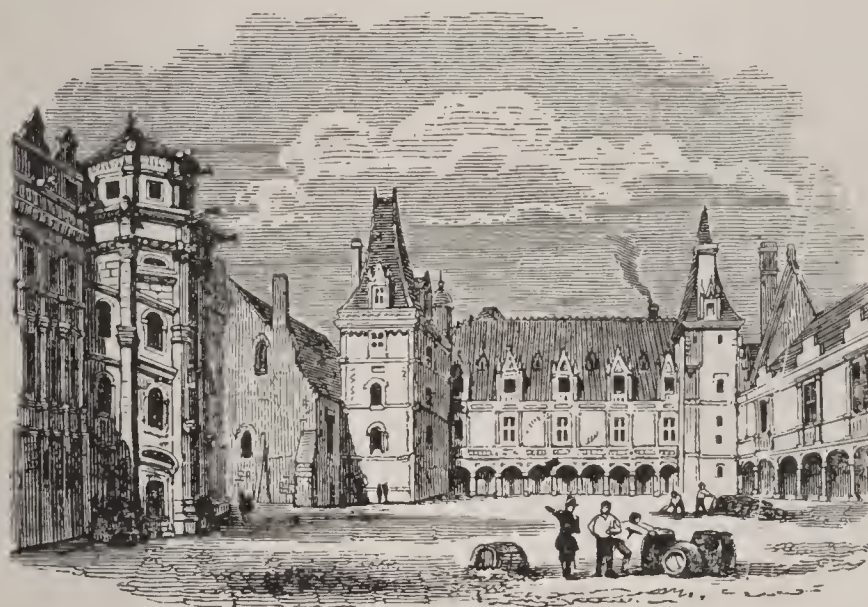

Court of the Castle of Blois

each section generally stretching from one station to the next, with a signal and telegraphic connection at the end of each section. The essential principle of the system is that no train is allowed to enter upon any one section till the section is signalled wholly clear, so that between two successive trains there is not merely an interval of time, but also an interval of space.

**Block-tin**, tin at a certain stage of refinement, but not quite pure.

**Bloemaart** (blö'märt), ABRAHAM, a Dutch painter, born about 1565, died in 1657. He was the son of an architect and sculptor, who sent him to Paris, where he studied for three years, subsequently returning to Amsterdam and Utrecht, where he settled and painted all sorts of subjects, his landscapes being the most esteemed. He had four sons, of whom Cornelis (born 1603, died 1680) was sent by his father as an art student to Paris, and afterwards lived and worked in Rome as a distinguished engraver.

**Bloemfontein** (blöm'fon-tin), the chief town and seat of government of the Orange

Free State, South Africa, 680 miles N.E. of Cape Town, situated in a high but healthy region. Pop. 2600.

**Blois** (blwä), capital of the French dep. Loir-et-Cher, 99 miles s.s.w. Paris, on the Loire. It consists of an upper town, a lower town, and several suburbs, with one of which it communicates by a stone bridge of eleven arches. The old castle, which has played an important part in French history, was restored by the government in 1845.

The main entrance is by a fine Gothic portal opening into a quadrangle, on the east side of which is a pillared cloister, on the north a pile of buildings in the Renaissance style, on the west some unfinished buildings, and on the south is the ancient part begun by the Dukes of Orleans. There is also a cathedral of late date, the Church of St. Nicholas (12th century), a bishop's palace, Roman aqueduct, &c. The castle was long occupied by the counts of the name; and became a favourite residence of the kings of France. Louis XII. was born, Francis I., Henry II., Charles IX., and Henry III. held their courts in it. Pop. 21,077.

**Blomfield**, CHARLES JAMES, Bishop of London, born at Bury-St.-Edmunds in 1786, died at Fulham 1857. He studied at Cambridge, where he took high honours; and after filling successively several curacies, and acting for a time as chaplain to the Bishop of London, was presented to the rectory of St. Botolph, Bishopsgate. In 1824 he was made Bishop of Chester, and in 1828 Bishop of London. He was a distinguished classical scholar, and published editions of several of the dramas of Æschylus and one of Callimachus. His chief distinction was gained by his activity in the management of his diocese, and his energy in the cause of church extension.

**Blond**, JACQUES CHRISTOPHE LE, miniature painter and originator of colour printing, born at Frankfort-on-the-Main 1670, died in an hospital in Paris 1741. He spent the most of his life and all his means in comparatively unsuccessful experiments in printing engravings in colour, and in attempts to reproduce the cartoons of Raphael in tapestry

**Blon'del**, a French minstrel and poet of the twelfth century, a confidential servant and instructor in music of Richard Cœur de Lion. While his master was the prisoner of the Duke of Austria, Blondel, according to the story, went through Palestine and all parts of Germany in search of him. He sang the king's own favourite lays before each keep and fortress till the song was at length taken up and answered from the windows of the castle of Loewenstein, where Richard was imprisoned. This story is preserved in the Chronicles of Rheims, of the thirteenth century. The poems of Blondel, with all the legendary and historical data relating to him, were published by Prosper Tarbé (Rheims, 1862).

**Blood**, the fluid which circulates through the arteries and veins of the human body and that of other animals, which is essential to the preservation of life and nutrition of the tissues. This fluid is more or less red in vertebrates, except in the lowest fishes. In insects and in others of the lower animals there is an analogous fluid which may be colourless, red, bluish, greenish, or milky. The venous blood of mammals is a dark red, but in passing through the lungs it becomes oxidized and acquires a bright scarlet colour, so that the blood in the arteries is of a brighter hue than that in the veins. The central organ of the blood circulation is the heart (which see). The specific gravity of human blood varies from 1.045 to 1.075, and its normal temperature is 99° Fahr. 1000 parts contain 783.37 of water, 2.83 fibrin, 67.25 albumen, 126.31 blood corpuscles, 5.16 fatty matters, 15.08 various animal matters and salts. When ordinary blood stands for a time it separates into two portions, a red coagulated mass consisting of the fibrin, corpuscles, &c., and a yellowish watery portion, the serum. The blood *corpuscles* or *globules* are characteristic of the fluid. These are minute, red and white bodies floating in the fluid of the blood. The red ones give colour to the fluid, and are flattish discs, oval in birds and reptiles, and round in man and most mammals. In man they average  $\frac{1}{300}$ th inch in diameter, and in the Proteus, which has them larger than any other vertebrate,  $\frac{1}{100}$ th inch in length and  $\frac{1}{27}$ th in breadth. The white or colourless corpuscles are the same as the lymph or chyle corpuscles, and are spherical or lenticular, nucleated, and granulated, and rather larger than the red globules.

**Blood**, AVENGER OF, in Scripture, the

nearest relation of any one that had died by manslaughter or murder, so called because it fell to him to punish the person who was guilty of the deed.

**Blood**, THOMAS (commonly called Colonel Blood), born in Ireland about 1618, died in London 1680, was a disbanded officer of Oliver Cromwell, and lost some estates in Ireland at the Restoration. His whole life was one of plotting and adventure, though it is probable that he acted a double part, keeping the government informed of so much as might secure his own safety. His most daring exploit was an attempt to steal the crown jewels (9th May, 1671) from the Tower. He was seized with the crown in his possession, but was not only pardoned by Charles, but obtained forfeited Irish estates of £500 annual value.

**Blood-bird** (*Myzomela sanguinolenta*), an Australian species of honey-sucker so called from the rich scarlet colour of the head, breast, and back of the male.

**Blood-flower**, the popular name for some of the red-flowered species of *Hæmanthus*, a genus of bulbous plants of the Amaryllis family, natives of the Cape of Good Hope. The most common species is *Hæmanthus coccineus*, or Cape Tulip, a very showy plant, the bulb of which is used as a diuretic.

**Blood-hound**, a variety of dog with long smooth and pendulous ears, remarkable for



Blood-hound.

the acuteness of its smell, and employed to recover game or prey which has escaped wounded from the hunter, by tracing the lost animal by the blood it has spilt: whence the name of the dog. There are several varieties of this animal, as the English, the Cuban, and the African bloodhound. In former times blood-hounds were not only trained to the pursuit of game, but also to the chase of man. In America they used to be employed in hunting fugitive slaves.

**Blood-letting.** See *Phlebotomy*.

**Blood-money**, the compensation by a homicide to the next of kin of the person slain, securing the offender and his relatives against subsequent retaliation; once common in Scandinavian and Teutonic countries, and still a custom among the Arabs. The term is also applied to money earned by laying or supporting a charge implying peril to the life of an accused person.

**Blood-rain**, showers of grayish and reddish dust mingled with rain which occasionally fall usually in the zone of the earth which extends on both sides of the Mediterranean westwardly over the Atlantic, and eastwardly to Central Asia. The dust is largely made up of microscopic organisms, especially the shells of diatoms; the red colour being owing to the presence of a red oxide of iron.

**Blood-root** (*Sanguinaria canadensis*), a plant of Canada and the U. States, belonging to the poppy order, and so named from its root-stock yielding a sap of a deep orange colour. Its leaves are heart-shaped and deeply lobed, the flower grows on a scape and is white or tinged with rose. The plant has acrid narcotic properties, and has been found useful in various diseases. *Geum canadense*, another American plant used as a mild tonic, is also known as blood-root.

**Blood-stone.** See *Heliotrope*.

**Blood-vessels** are the tubes or vessels in which the blood circulates. See *Arteries*, *Veins*, *Heart*.

**Blood-wood**, a name of several trees. Indian blood-wood (*Lagerstræmia reginae*), is a large tree of the henna family with wood of a blood-red colour, used for many purposes. It is called also *jarool*.

**Blood-wort**, same as blood-root (*Sanguinaria*).

**Bloody Assizes**, those held by Judge Jeffreys in 1685, after the suppression of Monmouth's rebellion. Upwards of 300 persons were executed after short trials; very many were whipped, imprisoned, and fined; and nearly 1000 were sent as slaves to the American plantations.

**Bloom**, a lump of puddled iron, which leaves the furnace in a rough state, to be subsequently rolled into the bars or other material into which it may be desired to convert the metal. Also a lump of iron made directly from the ore by a furnace called a 'bloomery.'

**Bloomer Costume**, a style of dress adopted about the year 1849 by Mrs. Bloomer of

New York, who proposed thereby to effect a complete revolution in female dress, and add materially to the health and comfort of women. It consisted of a jacket with close sleeves, a skirt reaching a little below the knee, and a pair of Turkish pantaloons secured by bands round the ankles.

**Bloom'field**, ROBERT, an English poet, born in Suffolk 1766, died in Bedfordshire 1823. In 1781 he was sent to learn the trade of a shoemaker with his brother in London. In the country, where he resided for a short time in 1786, he first conceived the idea of his poem the Farmer's Boy, which was written under the most unfavourable circumstances in a London garret. It was published in 1800, and had a great popularity. He subsequently published *Rural Tales*, *Wild Flowers*, *The Banks of the Wye*, *May Day with the Nurses*, &c. Several efforts were made to place him in comfortable circumstances, but he became hypochondriacal, and died in poverty.

**Bloom'ington**, a thriving city, state of Illinois, U.S., 60 m. N.N.E. of Springfield. It has several important educational institutions, including the Illinois Wesleyan University, a college for women, and the state Normal University in the vicinity. Has coal-mines, iron industries, railway works, &c., and a large trade. Pop. 20,484.

**Blount** (blunt), CHARLES, son of Sir H. Blount, born 1654; a deistical writer, is said to have had the assistance of his father in writing a work called *Anima Mundi*, or a *Historical Account of the Opinions of the Ancients concerning the Human Soul after Death*, &c. He wrote various other works of the same nature, and also an excellent treatise on the liberty of the press. He shot himself 1693, in consequence of the refusal of his deceased wife's sister to marry him.

**Blount**, SIR HENRY, English traveller, born 1602, died 1682. He travelled through various parts of the s. of Europe and Egypt, and published an account of his travels, which passed through at least eight editions. He was knighted by Charles I., and during the civil war took part with the royalists. After the king's death he came to London, and was employed by Cromwell and the Parliament in several important affairs.

**Blouse** (blouz), a light loose upper garment, resembling a smock-frock, made of linen or cotton, and worn by men as a protection from dust or in place of a coat. A blue linen blouse is the common dress of French workmen.

**Blow**, JOHN, a musical composer, born in 1648, died 1708. He became organist of Westminster Abbey, and was afterwards appointed composer to the Royal Chapel. His secular compositions were published under the name of Amphion Anglicus.

**Blow-fly**, a name for *Musca vomitoria*, *Sarcophaga carnaria*, and other species of two-winged flies that deposit their eggs on flesh, and thus taint it.

**Blowing-machine**, any contrivance for supplying a current of air, as for blowing glass, smelting iron, renewing the air in confined spaces, and the like. This may consist of a single pair of bellows, but more generally two pairs are combined to secure continuity of current. The most perfect blowing-machines are those in which the blast is produced by the motion of pistons in a cylinder, or by some application of the fan principle. For smelting and refining furnaces, where a blast with a pressure of 3 or 4 lbs. to the square inch is required, blowing-engines of large size and power, worked by steam, are employed.

**Blow-pipe**, an instrument by which a current of air or gas is driven through the flame of a lamp, candle, or gas jet, and that flame directed upon a mineral substance, to fuse or vitrify it, an intense heat being created by the rapid supply of oxygen and the concentration of the flame upon a small



Blow-pipe — a Ball to catch moisture from the mouth.

area. In its simplest form it is merely a conical tube of brass, glass, or other substance, usually 7 inches long and  $\frac{3}{4}$  inch in diameter at one end, and tapering so as to have a very small aperture at the other, within 2 inches or so of which it is bent nearly to a right angle, so that the stream of air may be directed sideways to the operator. The flame is turned to a horizontal direction, assumes a conical shape, and consists of two parts of different colours. The greatest heat is obtained at the tip of the inner blue flame. Here the substance subjected to it is burned or oxidized, a small piece of lead or copper, for instance, being converted into its oxide. Hence the name of the *oxidizing* flame. By shifting the substance to the interior blue flame, which is wanting in oxygen, this element will be abstracted from the substance, and a metallic oxide, for instance, will give out its metal; hence this is called a *reducing* flame.

Thus various minerals can be either oxidized or reduced at pleasure, and the pipe forms a ready test in the hands of the mineralogist, who may use fluxes along with substances tested, watch how they colour the flame, what vapour they give out, &c. The blow-pipe may be provided with several movable nozzles to produce flames of different sizes. The current of air is often formed by a pair of bellows instead of the human breath, the instrument being fixed in a proper frame for the purpose. The most powerful blow-pipe is the oxyhydrogen or compound blow-pipe, an instrument in which oxygen and hydrogen (in the proportions necessary to form water), propelled by hydrostatic or other pressure, and coming from separate reservoirs, are made to form a united current in a capillary orifice at the moment when they are kindled. The heat produced is such as to consume the diamond and to dissipate in vapour or in gaseous forms most known substances. The blow-pipe is used by goldsmiths and jewellers in soldering, by glass-workers in sealing the ends of tubes, &c., and extensively by chemists and mineralogists in testing the nature and composition of substances.

The name is also given to the pipe or tube through which poisoned arrows are blown by the breath, used by South American Indians and natives of Borneo. The tube or blow-pipe is 8 to 12 feet long, with a bore scarcely large enough to admit the little finger; and the arrow is forced through by a sudden expulsion of air from the lungs (like a pea from a boy's pea-shooter), being sometimes propelled to a distance of 140 yards.

**Blubber**, the fat of whales and other large sea animals, from which train-oil is obtained. The blubber lies under the skin and over the muscular flesh. It is eaten by the Eskimo and the sea-coast races of the Japanese islands, the Kuriles, &c. The whole quantity yielded by one whale ordinarily amounts to 40 or 50, but sometimes to 80 or more cwts.

**Blücher** (blü'her), GEBHARD LEBERECHE VON, distinguished Prussian general, born at Rostock 1742, died at Kriebowitz, in Silesia, 1819. He entered the Swedish service when 14 years of age and fought against the Prussians, but was taken prisoner in his first campaign, and was induced to enter the Prussian service. Discontented at the promotion of another officer over his head, he left the army, devoted himself to agriculture,

and by industry and prudence acquired an estate. After the death of Frederick II. he became a major in his former regiment, which he commanded with distinction on the Rhine in 1793 and 1794. After the battle of Kirrweiler in 1794 he was appointed major-general of the army of observation stationed on the Lower Rhine. In 1802, in the name of the King of Prussia, he took possession of Erfurt and Mühlhausen. Oct. 14, 1806, he fought at the battle of Auerstädt. After the Peace of Tilsit he laboured in the department of war at Königs-



Blücher.

berg and Berlin. He then received the chief military command in Pomerania, but at the instigation of Napoleon was afterwards, with several other distinguished men, dismissed from the service. In the campaign of 1812, when the Prussians assisted the French, he took no part; but no sooner did Prussia rise against her oppressors than Blücher, then seventy years old, engaged in the cause with all his former activity, and was appointed commander-in-chief of the Prussians and the Russian corps under General Winzingerode. His heroism in the battle of Lützen (May 2, 1813) was rewarded by the Emperor Alexander with the order of St. George. The battles of Bautzen and Hanau, those on the Katzbach and Leipzig, added to his glory. He was now raised to the rank of field-marshal, and led the Prussian army which invaded France early in 1814. After a period of obstinate conflict the day of Montmartre crowned this campaign, and, March 31, Blücher entered the capital of France. His king, in remembrance of the victory which he had gained at the Katzbach, created him Prince of Wahlstadt, and gave

him an estate in Silesia. On the renewal of the war in 1815 the chief command was again committed to him, and he led his army into the Netherlands. June 15 Napoleon threw himself upon him, and Blücher, on the 16th, was defeated at Ligny. In this engagement his horse was killed, and he was thrown under his body. In the battle of the 18th Blücher arrived at the most decisive moment upon the ground, and taking Napoleon in the rear and flank assisted materially in completing the great victory of Belle Alliance or Waterloo. He was a rough and fearless soldier, noted for his energy and rapid movements, which had procured him the name of 'Marshal Vorwärts' (Forward).

Blue, one of the seven colours into which the rays of light divide themselves when refracted through a glass prism, seen in nature in the clear expanse of the heavens; also a dye or pigment of this hue. The substances used as blue pigments are of very different natures, and derived from various sources; they are all compound bodies, some being natural and others artificial. They are derived almost entirely from the vegetable and mineral kingdoms. The principal blues used in painting are *ultramarine*, which was originally prepared from lapis-lazuli or azure-stone—a mineral found in China and other oriental countries—but, as now prepared, it is an artificial compound of china-clay, carbonate of soda, sulphur, and charcoal; *Prussian* or *Berlin blue*, which is a compound of cyanogen and iron; *blue bice*, prepared from carbonate of copper; *indigo blue*, from the indigo plant. Besides these, there are numerous other blues used in art, as *blue-verditer*, *smalt-* and *cobalt-blue*, from cobalt, *lacmus*, or *litmus*, &c. Before the discovery of aniline or coal-tar colours dyers chiefly depended for their blues on *woad*, *archil*, *indigo*, and *Prussian blue*, but now a series of brilliant blues are obtained from coal-tar, possessing great tinctorial power and various degrees of durability.—*Blue*, sometimes called *true blue*, was the favourite colour of the Scottish Covenanters of the 17th century. After the Revolution of 1688 it was combined with orange or yellow as the Whig colours. These were adopted on the cover of the Whig periodical, the *Edinburgh Review*, first published in 1802.

Bluebeard, the hero of a well-known tale, originally French, founded, it is believed, on the enormities of a real personage, Gilles de Laval, Count de Retz, a great nobleman of

Brittany, put to death for his crimes in 1440.

**Blue-bell**, a name given to the wild hyacinth (*Scilla nutans*) and to the hare-bell (*Campanula rotundifolia*).

**Blue-berry**, an American species of whortleberry (*Vaccinium pennsylvanicum*).

**Blue-bird**, a small dentirostral, insectivorous bird, the *Erythaca*, or *Sialia Wilsoni*, very common in the United States. The upper part of the body is blue, and the throat and breast of a dirty red. It makes its nest in the hole of a tree or in the box that is so commonly provided for its use by the friendly farmer. The blue-bird is the harbinger of spring to the Americans; its song is cheerful, continuing with little interruption from March to October, but is most frequently heard in the serene days of the spring. It is also called *blue robin* or *blue redbreast*, and is regarded with the same sort of sentiments as the robin of Europe.

**Blue-books**, the official reports, papers, and documents printed for the British government and laid before the Houses of Parliament. They are so called simply from being stitched up in dark-blue paper wrappers, and include bills presented to and acts passed by the houses; all reports and papers moved for by members or granted by government on particular subjects; the reports of committees; statistics of the trade, &c., also, in America and England, a book containing the names of all persons holding public offices, with other particulars.

**Blue Bottle**, *Centaurea Cyänus*, Bachelor's button, rather tall and slender, with blue flowers, growing in corn-fields.

**Blue-bottle Fly**, a large blue species of blow-fly (*Musca vomitoria*).

**Blue-breast**. Same as *Blue-throat*.

**Blue-coat School**. See *Christ's Hospital*.

**Blue-fish** (*Temnodon* or *Pomatomus saltator*), a fish common on the eastern coasts of America, allied to the mackerel, but larger, growing to the length of three feet or more, and much esteemed for the table. It is very destructive to other fishes. It is also called horse-mackerel, green-fish, skip-jack, &c.

**Blue-gowns**, an order of paupers in Scotland, called also the *King's Bedesmen*, to whom the kings annually distributed certain alms on condition of their praying for the royal welfare. Their number was equal to the number of years the king had lived. The alms consisted of a blue gown or cloak, a purse containing as many shillings Scots

(pennies sterling) as the years of the king's age, and a badge bearing the words '*Pass and repass*,' which protected them from all laws against mendicity. Edie Ochiltree, in Sir W. Scott's novel of the Antiquary, is a type of the class. The practice of appointing bedesmen was discontinued in 1833, and the last of them drew his last allowance from the exchequer in Edinburgh in 1863.

**Blue-grass** (*Poa pratensis*), an American pasture grass of great excellence, especially abundant in Kentucky.

**Blue John**, a name for fluor-spar.

**Blue Laws**, a name for certain laws said to have been made in the early government of New Haven, Connecticut, against breaches of manners and morality, but most of which probably never existed.

**Blue Light**. See *Bengal Light*.

**Blue-mantle**, one of the English pursuivants-at-arms, connected with the Herald's College.

**Blue Mountains**, the central mountain range of Jamaica, the main ridges of which are from 6000 to 8000 feet high. Also a mountain chain of New South Wales, part of the great Dividing Range. The highest peaks rise over 4000 feet above the sea. The range is now traversed by a railway, which attains a maximum height of 3494 feet.

**Blue Nile**. See *Nile*.

**Blue Peter**, a blue flag having a white square in the centre, used to signify that the ship on which it is hoisted is about to sail.

**Blue-pill**, a preparation of mercury for medicinal use. It consists of two parts by weight of mercury triturated with three parts of conserve of roses till it loses its globular form. This is mixed with one part by weight of liquorice root powder, so that 5 grains of the mixture contain 1 grain of mercury.

**Blue Ridge**, the most easterly ridge of the Alleghany or Appalachian Mountains. The most elevated summits are the peaks of Otter (4000 feet) in Virginia.

**Blue-stocking**, a literary lady: applied usually with the imputation of pedantry. The term arose in connection with certain meetings held by ladies in the days of Dr. Johnson for conversation with distinguished literary men. One of these literati was a Mr. Benjamin Stillingfleet, who always wore blue stockings, and whose conversation at these meetings was so much prized that his absence at any time was felt



to be a great loss, so that the remark became common, 'We can do nothing without the *blue-stockings*;' hence these meetings were sportively called *blue-stocking clubs*, and the ladies who attended them *blue-stockings*.

**Blue-stone**, or BLUE-VITRIOL, sulphate of copper, a dark-blue crystalline salt used in dyeing and for other purposes.

**Blue-throat**, a bird (*Sylvia succica*) with a tawny breast marked with a sky-blue crescent, inhabiting the northern parts of Europe and Asia. It is a bird of passage, and is taken in great numbers in France for the table.

**Blue-vitriol**. See *Blue-stone*.

**Blue-wing**, a genus of American ducks, so called from the colour of the wing-coverts. One species (*Querquedula discors*) is brought in great quantities to market, the flesh being highly esteemed for its flavour.

**Bluffs**, the name in America for the steep banks of a stream or lake forming prominent headlands, and often extending inland as plateaus.

**Blumenbach** (blö'men-bâh), JOHANN FRIEDRICH, celebrated German naturalist, born 1752, died 1840. He studied at Jena and Göttingen, and wrote on the occasion of his graduation as M.D. a remarkable thesis on the varieties of the human race. He became professor of medicine, librarian, and keeper of the museum at Göttingen in 1778, where he lectured for fifty years. His principal works are the *Institutiones Physiologicae*, long a common text-book; *Handbuch der vergleichenden Anatomie* (Handbook of Comparative Anatomy), the best treatise that had appeared up to its date; and *Collectio Craniorum Diversarum Gentium*. The last work, published between 1790 and 1828, gives descriptions and figures of his extensive collection of skulls, still preserved at Göttingen. He advocated the doctrine of the unity of the human species, which he divided into five varieties, Caucasian, Mongolian, Negro, American, and Malay. His anthropological treatises, and the memoirs of his life by Marx and Flourens, were translated into English.

**Blun'derbuss**, a short gun with a very wide bore, capable of holding a number of slugs or bullets, and intended to do execution at a limited range without exact aim.

**Blunt**, JOHN HENRY, English theological writer, born 1823, died 1884. He held various curacies, and latterly was appointed to the living of Beverston, Gloucestershire.

He wrote much, among his chief works being *Dictionary of Doctrinal and Historical Theology*; *Dictionary of Sects, Heresies, &c.*; *History of the English Reformation*; *Household Theology*; *Annotated Book of Common Prayer*.

**Blunt**, JOHN JAMES, English divine, born 1794, died 1855; from 1839 Lady Margaret professor of divinity at Cambridge. His works include articles contributed to the *Quarterly Review*; *Sketch of the Reformation in England*; *Undesigned Coincidences in the Old and New Testament*, an Argument for their Veracity; *On the Right Use of the Early Fathers*; *History of the Church during the First Three Centuries*; *Sermons*; &c.

**Boa**, a genus of serpents, family Boidæ, having the jaws so constructed that these animals can dilate the mouth sufficiently to swallow bodies thicker than themselves. They are also distinguished by having a hook on each side of the vent; the tail prehensile; the body compressed and largest in the middle, and with small scales, at least on the posterior part of the head. The genus includes some of the largest species of serpents, reptiles endowed with immense muscular power. They seize sheep, deer, &c., and crush them in their folds, after which they swallow the animal whole. The boas are peculiar to the hot parts of South America. The *Boa constrictor* is not one of the largest members of the genus, rarely exceeding 20 feet in length; but the name boa or boa constrictor is often given popularly to any of the large serpents of similar habits, and so as to include the Pythons of the Old World and the Anaconda and other large serpents of America.

**Boab'dil**, ABU-ABDULLAH, last Moorish king of Granada, gained the throne in 1481 by expelling his father, Mulei Hassan; and became the vassal of Ferdinand of Aragon. By his tyranny he provoked the hostility of his own subjects, and Ferdinand, taking advantage of the dissensions which prevailed, laid siege to Granada. The Moors made a valiant defence, but Boabdil capitulated, and retired to a domain of the Alpujarras assigned him by the victor. He afterwards passed into Africa, and fell in battle while assisting the King of Fez in an attempt to dethrone the King of Morocco.

**Boadice'a**, Queen of the Iceni, in Britain, during the reign of Nero. Having been treated in the most ignominious manner by the Romans, she headed a general insurrec-

tion of the Britons, attacked the Roman settlements, reduced London to ashes, and put to the sword all strangers to the number of 70,000. Suetonius, the Roman general, defeated her in a decisive battle (A.D. 62), and Boadicea, rather than fall into the hands of her enemies, put an end to her own life by poison.

**Boar**, the male of swine not castrated. The wild hog, the original of the domestic pig, is generally spoken of as the *wild boar*. See *Hog*.

**Board**, a number of persons having the management, direction, or superintendence of some public or private office or trust; also an office under the control of an executive government, the business of which is conducted by officers specially appointed for that purpose.

*Board of Admiralty*, the officers appointed for the administration of the naval affairs of Britain. The chief of the board is called First Lord. See *Admiralty*.

*Board of Trade*, a department of the British government, having wide and important functions respecting the trade and navigation of the kingdom. It is a permanent committee of the privy-council, and is presided over by a member of the cabinet. It is divided into eight departments each having its separate staff: (1) The *Commercial Department*, whose duties are to advise the treasury and the colonial and foreign offices on matters relating to tariffs and burdens on trade, &c. (2) The *Statistical Department*, which has to prepare the official volumes of statistics which are periodically issued. It may also be required to prepare special statistical returns for the information of members of parliament, chambers of commerce, or private persons who have occasion to apply. (3) The *Railway Department*, which has the supervision of railways and railway companies, and which must be supplied with notices of application for railway acts and with plans, before the relative bill can be brought before parliament. Before a line is opened for traffic the permission of the board on the report of an inspector must be got; and on the occurrence of an accident notice must be sent to the department, which is then empowered to take any measures it may deem necessary for the public safety or interest. It also keeps a register of joint-stock companies, of the accounts of insurance companies, and prepares provisional orders relating to gas, water, and tramway companies.

(4) The *Harbour Department*, which exercises a supervision over lighthouses, the sea-fisheries, pilotage, &c. (5) The *Marine Department* has to see to the registration, condition, and discipline of merchant ships, to watch over the mercantile marine offices, and to see that the regulations with regard to the engagement of seamen and apprentices are carried out; to examine officers, and make investigations into misconduct and wrecks; and generally to take in hand most of the business thrown upon the board by the various shipping acts. (6) The *Financial Department*, which has to keep the accounts of the board, controlling the receipts and expenditure. It has also to deal with Greenwich pensions, seamen's savings-banks and money orders, the proper distribution of the effects of seamen dying abroad, and the like. (7) The *Fisheries Department* regulates both the inland and sea fisheries of the country. (8) The *Bankruptcy Department* appoints official receivers, and generally carries out all the provisions of the law regarding bankruptcy.

The *Local Government Board* is a department of the British government presided over by a crown-appointed president. Its duties include the supervision and control of sanitary matters, questions of local government and municipal improvements, and the keeping of highways; and the board has further to report upon private bills.

**Boat**, a small open vessel or water craft usually moved by oars or rowing. The forms, dimensions, and uses of boats are very various, and some of them carry a light sail. The boats belonging to a ship of war are the launch or long-boat, which is the largest, the barge, the pinnace, the yawl, cutters, the jolly-boat, and the gig. The boats belonging to a merchant vessel are the launch or long-boat, before mentioned, the skiff, the jolly-boat or yawl, the stern-boat, the quarter-boat, and the captain's gig. Every British passenger ship is required to carry a number of boats according to the following scale: two boats for every ship of less than 200 tons; three, when 200 and less than 400; four, 400 and less than 600; five, 600 and less than 1000; six, 1000 and less than 1500; seven, 1500 and upwards. One of such boats must in all cases be a long-boat, and one a properly-fitted life-boat. See *Rowing*, *Regatta*.

**Boat-bill**, *Cancerōma cochlearia*, a South American bird of the family Ardeidæ or herons, about the size of a common fowl,

with a bill not unlike a boat with the keel uppermost; its chief food is fish.

**Boat-fly**, *Notonecta glauca*, an aquatic hemipterous insect which swims on its back; the hind-legs aptly enough resembling oars, the body representing a boat: hence the name.

**Boat'swain** (commonly pronounced bō'sn), a warrant-officer in the navy who has charge of the sails, rigging, colours, anchors, cables, and cordage. His office is also to summon the crew to their duty, to relieve the watch, &c. In the merchant service one of the crew who has charge of the rigging and oversees the men.

**Bob'bin**, a reel or other similar contrivance for holding thread. It is often a cylindrical piece of wood with a head, on which thread is wound for making lace; or a spool with a head at one or both ends, intended to have thread or yarn wound on it, and used in spinning machinery (when it is slipped on a spindle and revolves therewith) and in sewing-machines (applied within the shuttle).

**Bobbin-net**, a machine-made cotton net, originally imitated from the lace made by means of a pillow and bobbins.

**Bob'bio**, a small town of N. Italy, prov. Pavia, the seat of a bishop, with an old cathedral, and formerly a celebrated abbey founded by St. Columbanus.

**Bob-o-link**. See *Rice-bunting*.

**Bobruisk**, a fortified town of Russia, gov. Minsk. Pop. 31,158.

**Boccaccio** (bok-kāt'chō), GIOVANNI, Italian novelist and poet, son of a Florentine merchant, was born, 1313, in Certaldo, a small town in the valley of the Elsa, 20 miles from Florence; died there 1375. He spent some years unprofitably in literary pursuits and the study of the canon law, but in the end devoted himself entirely to literature. He found a congenial atmosphere in Naples, where many men of letters frequented the court of King Robert, among the number being the great Petrarch. In 1341 Boccaccio fell in love with Maria, an illegitimate daughter of King Robert, who returned his passion with equal ardour, and was immortalized as Fiammetta in many of his best creations. His first work, a romantic love-tale in prose, *Filocolo*, was written at her command; as was also the *Teseide*, the first heroic epic in the Italian language, and the first example of the *ottava rima*. In 1341 he returned to Florence at his father's command, and during a three years' stay produced three important works,

*Ameto*, *L'amorosa Visione*, and *L'amorosa Fiammetta*, all of them connected with his mistress in Naples. In 1344 he returned to Naples, where Giovanna, the granddaughter of Robert, who had succeeded to the throne, received him with distinction. Between 1344 and 1350 most of the stories of the *Decameron* were composed at her desire or at that of Fiammetta. This work, on which his fame rests, consists of 100 tales represented to have been related in equal portions in ten days by a party of ladies and gentlemen at a country house near Florence while the plague was raging in that city. The stories in this wonderful collection range from the highest pathos to the coarsest licentiousness. They are partly the invention of the author, and partly derived from the fabliaux of mediæval French poets and other sources. On the death of his father Boccaccio returned to Florence, where he was greatly honoured, and was sent on several public embassies. Amongst others he was sent to Padua to communicate to Petrarch the tidings of his recall from exile and the restoration of his property. From this time an intimate friendship grew up between them which continued for life. They both contributed greatly to the revival of the study of classical literature, Boccaccio spending much time and money in collecting ancient manuscripts. In 1373 he was chosen by the Florentines to occupy the chair which was established for the exposition of Dante's *Divina Commedia*. His lectures continued till his death. Among his other works may be mentioned *Filostrato*, a narrative poem; *Il Ninfale Fiesolano*, a love story; *Il Corbaccio*, ossia *Il Labirinto d'Amore*, a coarse satire on a Florentine widow; and several Latin works. The first edition of the *Decameron* appeared without date or place, but is believed to have been printed at Florence in 1469 or 1470. The first edition with a date is that of Valdarfer, Venice, 1471; what is, perhaps, the only existing perfect copy of this was sold in London in 1812 for £2260.

**Boccage** (bok-äzh), MARIE ANNE DU, a French poetess, much admired and extravagantly praised by Voltaire, Fontenelle, Clairaut and others; born 1710, died 1802. Her writings comprise an imitation of *Paradise Lost*; the *Death of Abel*; the *Amazons*, a tragedy; and a poem called the *Columbiad*.

**Bocca Tigris**, or BOGUE, the embouchure of the principal branch of the Chu Kiang, or Canton river, China.

**Boccherini** (bok-ker-ē'nē), LUIGI, an Italian composer of instrumental music, was born in 1740 at Lucca, died at Madrid 1805. His compositions consist of symphonies, sestets, quintets, quartets, trios, duets, and sonatas for the violin, violoncello, and pianoforte. He never composed anything for the theatre; and of church compositions we find but one, his *Stabat Mater*.

**Bochart** (bo-shär), SAMUEL, French theologian and oriental scholar, born at Rouen 1599, died at Caen 1661, where he was Protestant clergyman. His chief works are his *Geographia Sacra* (1646), and his *Hierozoicon*, or treatise on the animals of the Bible (1663).

**Bochnia** (boh'ni-a), a town of Austria, in Galicia, gov. of Lemberg, 25 miles E.S.E. of Cracow; extensive mines yielding gypsum, zinc, and rock-salt. Pop. 8501.

**Bochold** (boh'olt), a town of Prussia, prov. of Westphalia, on the Aa; cotton-spinning and weaving, &c. Pop. 10,576.

**Bochum** (boh'um), a Prussian town, prov. of Westphalia, 5 miles E.N.E. of Essen; manufactories of iron, steel, hardwares, &c. Pop. 40,767.

**Bock**, BOCKBIER, a variety of German beer made with more malt and less hops than ordinary German beer, and therefore sweeter and stronger.

**Bock'enheim** (-hīm), town of Germany, forming almost a suburb of Hamburg; flourishing manufactures of machinery, &c. Pop. 17,457.

**Böckh** (beuk), PHILIPP AUGUST, an eminent German classical antiquary, born at Carlsruhe 1785, died at Berlin 1867. He was educated at Carlsruhe and Halle, and obtained in 1811 the chair of ancient literature in the University of Berlin, where he remained for the rest of his life. He opened a new era in philology and archæology by setting forth the principle that their study ought to be an historical method intended to reproduce the whole social and political life of any given people during a given period. Among his chief works are an edition of Pindar (1811-22); *The Public Economy of the Athenians*, 1817, translated into English and French; *Investigations into the Weights, Coins, and Measures of Antiquity*, 1838; and *Documents concerning the Maritime Affairs of Attica*, 1840. The great *Corpus Inscriptionum Græcarum* was begun by him with the intention of giving in it every Greek inscription known in print or manuscript.

**Bocland**, BOCKLAND, or BOOK-LAND, one of the original English modes of tenure of manor-land which was held by a short and simple deed under certain rents and free services. This species of tenure has given rise to the modern freeholds.

**Bode** (bo'de), JOHN ELERT, German astronomer, born 1747, died 1826. His best works are his *Astronomical Almanac* and his large *Celestial Atlas* (*Himmelsatlas*), giving a catalogue of 17,240 stars (12,000 more than in any former chart).—*Bode's Law* is the name given to an arithmetical formula, previously made known by Kepler and Titius of Wittenberg, expressing approximately the distances of the planets from the sun. It assumes the series 0, 3, 6, 12, 24, 48, 96, &c., each term after the second being double the preceding term; to each term 4 is added, producing the series 4, 7, 10, 14, 28, 56, 100, &c. These numbers are, with the exception of 28, roughly proportional to the distances between the planets and the sun. The law has no theoretical foundation.

**Boden-see.** See *Constance, Lake o'.*

**Bo'denstedt** (-stet), FRIEDRICH MARTIN, German poet and miscellaneous writer, born in 1819. Having obtained an educational appointment at Tiflis he published a work on the peoples of the Caucasus (1848), and *A Thousand and One Days in the East*, which were very successful. In 1854 he was appointed professor of Slavic at Munich, and in 1858 was transferred to the chair of old English. He had since been a theatrical director at Meiningen, had travelled in the U. States, &c. Among the best of his poetical works are the *Songs of Mirza-Schaffy*, purporting to be translations from the Persian, but really original, which have passed through over 100 editions. He translated Shakspeare's *Sonnets*, and in conjunction with other writers issued a new translation of Shakspeare's works. He died in 1892.

**Bodin** (bo-dan), JEAN, a French political writer, born in 1530 or 1529, died 1596. He studied law at Toulouse, delivered lectures on jurisprudence there, and afterwards went to Paris and practised. His great work *De la République* (1576) has been characterized as the ablest and most remarkable treatise on the philosophy of government and legislation produced from the time of Aristotle to that of Montesquieu.

**Bodle**, a copper coin formerly current in Scotland, of the value of two pennies Scots, or the sixth part of an English penny. The

name is said to have been derived from a mint-master of the name of Bothwell.

**Bodleian Library** at Oxford, founded by Sir Thomas Bodley in 1598, opened 1602. It claims a copy of all works published in Britain, and for rare works and MSS. it is said to be second only to the Vatican. In 1883 it contained 1,250,000 vols.

**Bodley**, SIR THOMAS, the founder of the Bodleian Library at Oxford, was born at Exeter in 1544, died in London 1612. He was educated partly at Geneva, whither his parents, who were Protestants, had retired in the reign of Queen Mary. On the accession of Elizabeth they returned home, and he completed his studies at Magdalen College, Oxford. He travelled much on the Continent, and was employed in various embassies to Denmark, Germany, France, and Holland. In 1597 he returned home, and dedicated the remainder of his life to the re-establishment and augmentation of the public library at Oxford. He expended a very large sum in collecting rare and valuable books, besides leaving an estate for the support of the library. He was knighted at the accession of James I. See *Bodleian Library*.

**Bod'mer**, JOHN JACOB, German poet and scholar, born 1698, died at Zürich 1783, where he had been professor of history for fifty years. Although he produced nothing remarkable of his own in poetry, he did great service by republishing the old German poets and by his numerous critical writings.

**Bodmer**, KARL, painter, was born in Zurich, Switzerland, in 1809. Many of his works were exhibited at the annual salons. He was a member of the Legion of Honor. He died October 31, 1893.

**Bodo'ni**, GIAMBATTISTA, celebrated Italian printer, born at Saluzzo 1740, died at Parma 1813. In 1758 he went to Rome, and was employed in the printing-office of the Propaganda. He was afterwards at the head of the ducal printing-house in Parma, where he produced works of great beauty. His editions of Greek, Latin, Italian, and French classics are highly prized.

**Boece** (bois), or BOYCE, HECTOR, Scottish historian, was born at Dundee about 1465. He studied first at Dundee, and then at the University of Paris, where he became professor of philosophy in the College of Montaigu, and made the acquaintance of Erasmus. About 1500 he quitted Paris to assume the principalship of the newly-founded university of King's College, Aberdeen. In

1522 he published in Paris a history in Latin of the prelates of Mortlach and Aberdeen. Five years afterward appeared the work on which his fame chiefly rests, the History of Scotland in Latin—*Scotorum Historiæ a prima gentis origine, &c.* It abounds in fable, but the *narrati e* seems to have been skilfully adjusted to the conditions of belief in his own time. In 1536 a translation of the history was published, made by John Ballentyne or Bellenden for James V. He died in 1536.

**Boehm** (bām), JOSEPH EDGAR, R.A., sculptor, born at Vienna 1834, of Hungarian parents. He studied art in Italy and Paris, and settled in England in 1862. He has executed many statues for public monuments, including those to Bunyan at Bedford, Carlyle and Tyndall on the Thames Embankment, Beaconsfield and Stanley for Westminster, &c., besides a great number of portrait-busts. In 1881 he was appointed sculptor-in-ordinary to the queen.

**Boehme** (beu'me), or BOEHM, JAKOB, German mystical writer, born in 1575, died in 1624. He was apprenticed to a shoemaker in his fourteenth year, and ten years later he was settled at Görlitz as a master-tradesman, and married to the daughter of a thriving butcher of the town. He was much persecuted by the religious authorities, and at his death the rites of the church were but grudgingly administered to him. Raised by contemplation above his circumstances, a strong sense of the spiritual, particularly of the mysterious, was constantly present with him, and he saw in all the workings of nature upon his mind a revelation of God, and even imagined himself favoured by divine inspirations. His first work appeared in 1616, and was called *Aurora*. It contains his revelations on God, man, and nature. Among his other works are *De tribus Principiis*, *De Signatura Rerum*, *Mysterium Magnum*, &c. His writings all aim at religious edification, but his philosophy is very obscure and often fantastic. The first collection of his works was made in Holland in 1675 by Henry Betke; a more complete one in 1682 by Gichtel (ten vols., Amsterdam). William Law published an English translation of them, two vols. 4to. A sect, taking their name from Boehme, was formed in England.

**Bœhmeria** (bē-mē'ri-a), a genus of plants, order Urticaceæ or Nettles, closely resembling our stinging nettle. A number of the species yield tenacious fibres, used for mak-

ing ropes, twine, net, sewing-thread. *B. nivēa* is the Chinese grass, the Malay *ramee*, which is shrubby and 3 or 4 feet high. It is a native of China, South-eastern Asia, and the Asiatic archipelago, where, and in India, it has long been cultivated. The plant has been introduced into cultivation in parts of the United States, Algeria, France, &c., under its Malay name of *ramee* or *ramie*. The British government have also become interested in its cultivation in such of the colonies or dependencies as are favourable to its growth. See *Ramee*.

**Bœo'tia**, a division of ancient Greece, lying between Attica and Phocis, and bounded E. and W. by the Eubœan Sea and the Corinthian Gulf respectively, had an area of 1119 square miles. The whole country is surrounded by mountains, on the S. Mounts Cithæron and Parnes, on the W. Mount Helicon, on the N. Mount Parnassus and the Opuntian Mountains, which also closed it in on the E. The northern part is drained by the Cephissus, the waters of which form Lake Copais; the southern by the Asopus, which flows into the Eubœan Sea. The country originally had a superabundance of water, but artificial drainage works made it one of the most fertile districts of Greece. The inhabitants were of the Æolian race, most of the towns formed a kind of republic, of which Thebes was the chief city. Epaminondas and Pelopidas raised Thebes for a time to the highest rank among Grecian states. Refinement and cultivation of mind never made such progress in Bœotia as in Attica, and the term Bœotian was used by the Athenians as a synonym for dulness, but somewhat unjustly, since Hesiod, Pindar, the poetess Corinna, and Plutarch were Bœotians. Along with Attica, Bœotia now forms a nomarchy of the kingdom of Greece, with a pop. 1889 of 257,764.

**Boerhaave** (bör'hä-ve), HERMANN, celebrated Dutch physician, was born 1668, died 1738. Destined for the clerical profession, in 1682 he was sent to Leyden to study theology. In 1689 he received the degree of Doctor of Philosophy, soon after he began the study of medicine, and in 1693 was made Doctor of Medicine at Harderwyck. In 1701 the University of Leyden chose him to deliver lectures on the theory of medicine; and in 1709 he was appointed to the chair of medicine and botany. He now published his *Institutiones Medicæ in Usus Annuæ Exercitationis*, and *Aphorismi*

*de Cognoscendis et Curandis Morbis in Usum Doctrinæ Medicinæ*, the former expounding his medical system, the latter classifying diseases and treating of their cause and cure. In 1714 he was made rector of the university.

**Boers** (börz; Dutch, *boer*, a peasant or husbandman), the Cape-Dutch name for the farmers of Dutch origin in South Africa. In 1836-37 large numbers of the Boers, being dissatisfied with the British government in Cape Colony, migrated northward to what is now Natal. Here their ill-treatment of the natives soon led to war, and the British had to interfere and ultimately (1843) annex the country. The Boers again migrated, but their new settlement was annexed in 1848. They then began to form the present Transvaal, where their ill-treatment of the coloured races has caused the British government again and again to interfere. They now occupy the Republics of the Transvaal, the Orange State, and the New Republic in Zululand, though the independence of the latter is not yet assured. The Boers, who are all rigid Calvinists, are described as frugal, industrious, and hospitable, but distrustful of foreigners, especially the English. In 1896 Dr. Jameson, of Br. South Africa, arranged with the Utlanders living in the Transvaal for armed resistance to the government, in support of the right of vote of each citizen, who, like the American colonies, were taxed without representation. The raid was a failure and the leaders were mostly imprisoned. Their aggressive and often treacherous policy and their cruelty to the natives go far, however, to outweigh any good qualities they may have shown. See *Transvaal, Orange Free State, Natal, and Zululand*.

**Boethius**, a Latinized form of *Boece*. See *Boece*.

**Boethius** (bo-ē'thi-us), ANICIUS MANLIUS SEVERINUS, a celebrated Roman statesman and philosopher, was born about 470 A.D. in Rome or Milan, of a rich and ancient family; executed 525. Theodoric, king of the Ostrogoths, then master of Italy, loaded him with marks of favour and esteem, and raised him to the first offices in the empire. He was three times consul, and received the greatest possible honour from people, senate, and king. But Theodoric, as he grew old, became irritable, jealous, and distrustful of those about him, and was worked upon by some whom Boethius had made

enemies by his strict integrity and vigilant justice. These at last succeeded in prejudicing the king against him, and he was accused of a treasonable correspondence with the court of Constantinople, imprisoned for a time, and then put to death. He made translations of the Greek philosophers, particularly Aristotle, which, in the middle ages, caused him to be regarded as the highest authority in philosophy. There is no evidence that he was a Christian. His fame now chiefly rests on his *Consolations of Philosophy*, written in prison, partly in prose and partly in verse, a work of elevated thought and diction. We have an Anglo-Saxon translation of it by King Alfred, and it was early translated into other languages.

**Bog**, a piece of wet, soft, and spongy ground, where the soil is composed mainly of decaying and decayed vegetable matter. Such ground is valueless for agriculture until reclaimed, but often yields abundance of peat for fuel. A bog seems usually to be formed as follows:—A shallow pool induces the formation of aquatic plants, which gradually creep in from the borders to the deeper centre. Mud accumulates round their roots and stalks, and a semi-fluid mass is formed, well suited for the growth of moss, particularly *Sphagnum*, which now begins to luxuriate, continually absorbing water, and shooting out new plants above as the old decay beneath; these are consequently rotted, and compressed into a solid substance, gradually replacing the water by a mass of vegetable matter. A layer of clay, frequently found over gravel, assists the formation of bog by its power of retaining moisture. When the subsoil is very retentive, and the quantity of water becomes excessive, the superincumbent peat sometimes bursts forth and floats over adjacent lands. Bogs are generally divided into two classes: red bogs, or peat-mosses, and black bogs, or mountain mosses. The former class are found in extensive plains frequently running through several counties, such as the Chatmoss in Lancashire, and the Bog of Allen in Ireland, the depth varying from 12 to 42 ft. Their texture is light and full of filaments, and is formed by the slow decay of mosses and plants of different kinds. The lower parts, being more entirely decayed, approach nearer to the nature of the humus than the upper portion, and, as being more carbonaceous, are more valuable for fuel. Black bog is formed by a more rapid decomposition of plants. It is heavier and

more homogeneous in quality, but is usually found in limited and detached portions, and at high elevations where its reclamation is difficult. In Ireland bogs frequently rest on a calcareous subsoil, which is of great value in reclaiming them. In the reclamation of bog land a permanent system of drainage must be established; the loose and spongy soil must be mixed with a sufficient quantity of mineral matter to give firmness to its texture and fertilize its superabundant humus; proper manures must be provided to facilitate the extraction of nutriment from the new soil, and a rotation of crops adopted suitable for bringing it into permanent condition. The materials best adapted for reclaiming peat are calcareous earths, limestone gravel, shell-marl, and shell-sand. Thoroughly reclaimed bogs are not liable to revert to their former condition. Trunks of trees are often found in bogs (see *Bog-oak*), as are also bones of extinct animals.

**Bogar'dus**, JAMES, an American inventor, born in 1800, died in 1874. Among his inventions were the 'ring-flyer' or 'ring-spinner' used in cotton manufacture (1828), the eccentric mill (1829), an engraving machine (1831), and the first dry gas-meter (1832). In 1839 he gained the reward offered for the best plan for carrying out the penny postage system by the use of stamps. In 1847 he built the first complete cast-iron structure in the world, and the first wrought-iron beams were made from his design. His delicate pyrometer and deep-sea sounding machine were valuable additions to scientific instruments.

**Bogatz'ky**, KARL HEINRICH VON, German Protestant theological writer, born 1690, died 1774. His principal works are: *Schatz-Kästlein der Kinder Gottes*, 1718; *Geistliche Gedichte*, 1749. The English translation of the former is well known by the title of Bogatzky's Golden Treasury.

**Bog-butter**, a fatty spermaceti-like mineral resin found in masses in peat-bogs, composed of carbon, oxygen, and hydrogen.

**Boghead Coal**, a brown cannel-coal of Scotland, found at Boghead, near Bathgate, and very valuable for gas and oil making.

**Bog Iron-ore**, a loose, porous, earthy ore of iron found in bogs and swamps, a hydrous peroxide, seldom occurring in such abundance as to render it of industrial importance.

**Boglipoor**. See *Bhagulpur*.

**Bog-oak**, trunks and large branches of oak found imbedded in bogs and preserved

by the antiseptic properties of peat, so that the grain of the wood is little affected by the many ages during which it has lain interred. It is of a shining black or ebony colour, derived from its impregnation with iron, and is frequently converted into ornamental pieces of furniture and smaller ornaments, as brooches, ear-rings, &c.

**Bogodukhoff** (-hof'), a town of Russia, in the government of Kharkov, with a considerable trade. Pop. 12,221.

**Bogomili** (bō-gō-mē'lē), an ascetic and mystical sect of the Greek Church founded in the 12th century. They held that God had two sons, Sathaniel and Logos, the former of whom rebelled and created the material world, but was finally subdued by the Logos or Christ. The sect was powerful in Bulgaria for about five centuries, and by its method of teaching did much to preserve and circulate old legends and folk-lore, including many early versions of Oriental fictions.

**Bog-ore.** See *Bog Iron-ore*.

**Bogos**, a Hamitic people of Northern Abyssinia, occupying a fine plateau and mountain district, and numbering about 10,000, almost entirely engaged in cattle-rearing, though there is some tillage and a trade in corn, butter, ivory, skins, buffalo-horns, and ostrich feathers. The men are well built and fairly handsome, the women of a lower type. They have peculiar patriarchal institutions with regularly established laws. The religion is the Christian, but Mohammedanism has a considerable number of adherents. Their chief village is Keren.

**Bogotá** (formerly *Santa Fé de Bogotá*), a city of South America, capital of Colombia and of the state or department of Cundinamarca, and seat of an archbishopric, situated on an elevated plain 8863 feet above the sea, at the foot of two lofty mountains, with a healthy though moist climate, and a temperature rarely exceeding 59° Fahr. Bogotá being subject to earthquakes, the houses are low, and strongly built of sun-dried brick. The principal street, *Calle Real*, is very handsome, terminating at one end in a square, formed by the palace of the president, the cathedral, the custom-house, &c. There are a university, four colleges, a public library, observatory, botanic garden, theatre, mint, &c. The inhabitants are mostly Creoles. Bogotá is an emporium of internal trade, and has manufactures of soap, cloth, leather, &c., not of great importance. It was founded in 1538. Pop.

about 100,000.—The plateau of Bogotá seems to be the basin of a dried-up lake. It is drained by the river Bogotá or Funza, which forms the fall of Tequendama, 650 feet high.

**Bog-trotter**, a term originally applied contemptuously to the Irish peasantry from the ability shown by them in crossing their native bogs by leaping from tussock to tussock—a frequent means of escape from police and soldiery.

**Bogue** (bog), an acanthopterygian fish (*Boöps* or *Box vulgaris*), family Sparidæ, or gilthead, found in the Mediterranean, and sometimes on the coasts of Britain. The eyes are large, and the general colouring brilliant.

**Bogue** (bōg), DAVID, the originator of the London Missionary Society, born in Berwickshire in 1750, died 1825. He studied at Edinburgh, and was licensed as a preacher of the Church of Scotland. In 1771 he was employed as usher in London, and afterwards became minister of an Independent chapel at Gosport, where he formed an institution for the education of young men for the Independent ministry. He then began the formation of the grand missionary scheme which afterwards resulted in the London Missionary Society, and took an active part in the foundation of the British and Foreign Bible Society and the Religious Tract Society. He wrote an *Essay on the Divine Authority of the New Testament* (1802); *Discourses on the Millennium* (1813–16); and, in conjunction with Dr. Bennet, a *History of Dissenters* (1809–12).

**Bo'gus**, an Americanism meaning counterfeit, and applied to any spurious or counterfeit object; as, a *bogus* government, a *bogus* law. The origin of the term is uncertain.

**Bohea** (bo-hē'), an inferior kind of black tea. The name is sometimes applied to black teas in general, comprehending Sou-chong, Pekoe, Congou, and common Bohea.

**Bohe'mia** (Ger. *Böhmen*), a province with the title of kingdom belonging to the Austro-Hungarian monarchy (Austrian or Cisleithan portion), bounded by Bavaria, Saxony, the Prussian province of Silesia, Moravia, and the archduchy of Austria; area 20,060 sq. miles; pop. 1891, 5,843,094; more than 2,000,000 are Germans, the rest mostly Czechs. The prevailing religion is the Roman Catholic, the country being an archbishopric with three bishoprics. The language of the country is the Czech dialect of the Slavonic (see *Czech Language*);



in some districts, and in most of the cities, German is spoken. Bohemia is surrounded on all sides by mountains, and has many large forests. Its plains are remarkably fertile. The chief rivers are the Elbe and its tributary the Moldau, which is even larger. All sorts of grain are produced in abundance, as also large quantities of potatoes, pulse, sugar-beet, flax, hops (the best in Europe), and fruits. Wine is not abundant, but in some parts is of pretty good quality. The raising of sheep, horses, swine, and poultry is carried on to a considerable extent. The mines yield silver, copper, lead, tin, zinc, iron, cobalt, arsenic, uranium, antimony, alum, sulphur, plumbago, and coal. There are numerous mineral springs, but little salt. Spinning and weaving of linen, cotton, and woollen goods are extensively carried on; manufactures of lace, metal and wood work, machinery, chemical products, beet-root sugar, pottery, porcelain, &c., are also largely developed. Large quantities of beer (Pilsener) are exported. The glass-ware of Bohemia, which is known all over Europe, employs 50,000 workers. The trade, partly transit, is extensive, Prague, the capital, being the centre of it. The largest towns are Prague, Pilsen, Reichenberg, Budweis, Teplitz, Aussig, and Eger. The educational establishments include the Prague University and upwards of 4000 ordinary schools. The province sends 92 representatives to the Austrian parliament; the provincial diet consists of 241 members.

Bohemia possesses a literature of considerable bulk, including in it also works written in Czech by Moravian and Hungarian writers. The earliest fragment is doubtfully referred to the 10th century, and it was not till after the 13th century that it attained to any development. The next century was a period of great activity, and to it belong versified legends, allegorical and didactic poems, historical and theological works, &c. The most flourishing period of the older literature falls within 1409–1620, John Huss (1369–1415) having initiated a new era, which, however, is more fertile in prose works than in poetry. The following period, up to the beginning of the 19th century was one of decline, but in recent times there has been a great revival, and in almost all departments Bohemian writers have produced works of merit.

Bohemia was named after a tribe of Gallic origin, the Boii, who were expelled from this region by the Marcomans at the com-

mencement of the Christian era. The latter were in turn obliged to give place to the Germans, and these to the Czechs, a Slavic race who had established themselves in Bohemia by the middle of the 5th century, and still form the bulk of the population. The country was at first divided into numerous principalities. Christianity was introduced about 900. In 1092 Bohemia was finally recognized as a kingdom under Wratislas II. In 1230 the monarchy, hitherto elective, became hereditary. The monarchs received investiture from the German emperor, held one of the great offices in the imperial court, and were recognized as among the seven electors of the empire. Frequently at strife with its neighbours, Bohemia was successively united and dis-united with Hungary, Silesia, Moravia, &c., according to the course of wars and alliances. Ottokar II. (1253–78) had extended his conquests almost from the Adriatic to the Baltic, when he lost them and his life in contest with Rudolph, the founder of the house of Hapsburg. After the close of the Przemysl dynasty (which had held sway for about six centuries) by the assassination of Ottokar's grandson, Wenceslas III., the house of Luxemburg succeeded in 1310, and governed Bohemia till 1437, the reign of Charles II. (1346–78) being especially prosperous. Towards the close of this second dynasty civil wars were excited by the spread of the Hussite movement, the central figure of the struggle being John Ziska, the leader of the Taborites. A temporary union between the moderate Hussites and the Catholics having proved a failure, the reformed party elected as king, in 1433, the Protestant noble, George Podibrad. On his death in 1471 they chose Wladislas, son of Cassimir, king of Poland, who also obtained the crown of Hungary. His son Louis lost both crowns with his life in the battle of Mohacz against the Turks, and Ferdinand of Austria became in 1527 sovereign of both kingdoms. Bohemia then lost its separate existence, being declared a hereditary possession of the house of Austria; and its subsequent history pertains to that of the Austrian Empire. In 1848 an attempt was made to assert its ancient independence against the Austrian dominion; a conflict took place, Prague was bombarded, and the insurrection suppressed.

**Bohemian Brethren**, a Christian sect of Bohemia, formed from the remains of the stricter sort of Hussites, in the latter half

of the 15th century. They took the Scriptures as the ground of their doctrines throughout, and sought to frame the constitution of their churches on the apostolic model. They had a rigid system of mutual supervision extending even to the minute details of domestic life. Being persecuted numbers retired into Poland and Prussia. Those who remained in Moravia and Bohemia, and who had their chief residence at Fulneck in Moravia, were hence called *Moravian Brethren* (which see).

**Bohemian Forest** (*Böhmerwald*), a mountain ridge extending from the Fichtelgebirge southward towards the confluence of the Ilz and the Danube, and separating Bavaria from Bohemia. The highest peaks are the Arber (4320 ft.) and the Rachel.

**Bohemond**, MARC, son of the Norman adventurer Robert Guiscard, who rose to be Duke of Apulia and Calabria, was born about 1056. After distinguishing himself in Greece and Illyria against Alexius Comnenus, he returned to find that in his absence his younger brother Roger had seized upon the paternal inheritance (1085). War ensued, but Bohemond, contenting himself with the principality of Tarentum, ultimately threw his energy into the Crusades. He took a leading part in the campaign in Asia Minor, captured Antioch (1098), and assumed the principality; but was taken prisoner in 1101 and held captive for two years. In 1106 he married Constance, daughter of Philip I. of France, and after an unsuccessful renewal of war with Alexius, died at Canossa in 1111. Five of his descendants held in succession the principality of Antioch for over a century and a half.

**Bohlen** (bō'len), PETER VON, German orientalist, born in 1796, died in 1840. Having devoted himself to the oriental languages, he obtained an appointment at Königsberg in 1825 as extraordinary, and in 1830 as ordinary professor of oriental literature. The most important of his writings is a *Das alte Indien* (Ancient India).

**Böhme.** See *Boehme*.

**Böhmisch-Leipa** (beu'mish-lī-pà), a town of Northern Bohemia, on the River Polzen. Pop. 10,170.

**Bohn** (bōn), HENRY GEORGE, English bookseller, born at London, of a German family, in 1796; died 1884. He was the publisher of the well-known 'Libraries,' or collection of standard works at moderate prices, to which he contributed some translations and works

edited by himself; and he prepared an edition of Lowndes's *Bibliographer's Manual*, &c.

**Böhtlingk** (beut'lingk), OTTO, German Sanskrit scholar, born at St. Petersburg in 1815; chief work, a Sanskrit-German dictionary in 7 vols. (St. Petersburg, 1853-75), prepared in conjunction with Prof. Roth of Tübingen.

**Boiar'do**, MATTEO MARIA, Count of Scandiano, Italian poet, scholar, knight, and courtier; born near Ferrara in 1434. From 1488 to 1494, the period of his death, he was commander of the city and castle of Reggio, in the service of Ercole d'Este, duke of Modena. His chief poem was his uncompleted *Orlando Innamorato* (1495), a romantic epic, the principal Italian poem before the *Orlando Furioso* of Ariosto, though now chiefly known by the *rifacimento* of Berni. His other works include a comedy, *Il Timone*; *Sonnetti e Canzoni*; *Carmen Bucolicum*; *Cinque Capitoli in terza rima*; and translations from Lucian, Apuleius, and Herodotus.

**Boi'ars**, BOY'ARS, an order of the old Russian aristocracy next in rank to the ruling princes, and bearing much the same relation to them as the lesser barons of England and Scotland did to the greater in the feudal ages. The boiars enjoyed many exclusive privileges, held all the highest military and civil offices, and were so powerful that the ancient imperial ukases contained the clause, 'The emperor has willed it, the boiars have approved it.' The order was abolished by Peter the Great, who gave its members a place in the Russian nobility.

**Bo'idæ**, a family of large non-venomous serpents, with two mobile hooks or spurs, the rudiments of hind-legs, near the anus. The type genus is *Boa* (which see).

**Boieldieu** (bwäl-dyeu), ADRIEN FRANÇOIS, a celebrated composer, born at Rouen in 1775. He early displayed great musical talent, his first opera, *La Famille Suisse*, being well received in 1795 at Rouen. In 1795 he repaired to Paris, and rose rapidly in reputation, producing several operas, of which the best was *Le Calife de Bagdad* (1799). Domestic difficulties drove him in 1802 to Russia, where he became musical director to the emperor. On his return to Paris in 1811 he produced, among other works, his two masterpieces, *Jean de Paris* (1812) and *La Dame Blanche* (1825), which place him in the first rank of composers of French comic opera. For some years he was professor of composition and the piano-

forte at the Conservatoire. He died of pulmonary disease in 1834.

**Boi'i**, a Celtic people, whose original seat is supposed to have been between the Upper Saône and the higher parts of the Seine and Marne. They migrated to Cisalpine Gaul, crossed the Po, and established themselves between it and the Apennines, in the country previously occupied by the Umbrians. After a more or less constant strife with the inhabitants of Southern Italy they attacked the Romans in support of Hannibal in B.C. 218, and though defeated, maintained the war until their subjugation by Scipio Nasica, B.C. 191. The remnant of the tribe sought refuge among the Tauriscans in the territory since called after them Bohemia, from which there was a later migration, about B.C. 58, to Bavaria, to which also they gave their name.

**Boil**, to heat a fluid up to the point at which it is converted into vapour. The conversion takes place chiefly at the point of contact with the source of heat, and the bubbles of vapour rising to the surface, and breaking there, produce the commotion called *ebullition*. At the ordinary atmospheric pressure ebullition commences at a temperature which is definite for each liquid. The escape of the heated fluid in the form of vapour prevents any further rise of temperature in an open vessel when the *boiling-point* has been reached. The exact definition of the boiling-point of a liquid is 'that temperature at which the tension of its vapour exactly balances the pressure of the atmosphere.' The influence of this pressure appears from experiments. In an exhausted receiver the heat of the human hand is sufficient to make water boil; while, on the contrary, in Papin's digester, in which it is possible to subject the water in the boiler to a pressure of three or four atmospheres, the water may be heated far above the normal boiling-point without giving signs of ebullition. From this relation between the ebullition of a liquid and atmospheric pressure the heights of objects above sea-level may be calculated by comparing the actual boiling-point at any place with the normal boiling-point. (See *Heights, Measurement of*). The boiling-point of water as marked on Fahrenheit's thermometer is 212°; on the Centigrade, 100°; on the Réaumur, 80°. Ether boils at about 96°, mercury at 662°.

**Boil**, a small painful swelling of a conical shape on the surface of the body. Its base

is hard, while its apex is soft and of a whitish colour. Boils are generally indicative of depressed health, intemperate habits, or disorder of the digestive organs. In treating a boil suppuration should be stimulated by poultices and fomentation; afterwards an incision should be made, and the matter, together with the dead cellular tissue or core, squeezed out. The stomach should be relieved by purgatives and tonics administered. Anodynes are sometimes necessary when the constitutional irritation is very great.

**Boileau-Despréaux** (bwä-lō-dā-prā-ō), NICHOLAS (commonly called *Boileau*), a French poet, born in 1636 at Paris. He studied in the Collège d'Harcourt and in the Collège de Beauvais, and entered the legal profession, but soon left it to devote himself entirely to belles-lettres. In 1660 appeared his first satire, *Adieux d'un Poète à la Ville de Paris*, followed rapidly by eight others, and ultimately by three more, to complete the series. They attacked with much critical acumen, and in vigorous but finely-finished verse, the poets and writers of the older school. In 1664 he wrote his prose *Dialogue des Heros de Roman*, which sounded the knell of the artificial romances of the period. His *Epistles*, written in a more serious vein, appeared at various times from 1669 onwards; but his masterpieces were the *L'Art Poétique* and *Le Lutrin*, published in 1674—the former an imitation of the *Ars Poetica* of Horace with reference to French verse, the latter a mock heroic poem. In many respects his writings determined the trend of all subsequent French poetry, and he left, through his influence upon Dryden, Pope, and their contemporaries, a permanent mark upon English literature. For some time he held the post of historiographer in connection with Racine, and was elected academician in 1684, though only after the interference of the king in his favour. He died in 1711 of dropsy.

**Boiler**, a vessel constructed of wrought iron or steel plates riveted together, with needful adjuncts, in which steam is generated from water for the purpose of driving a steam-engine, or for other purposes. The first important point in preparing a steam-boiler is to secure strength to resist the internal pressure of steam and prevent explosions; and accordingly the globular or spherical shape was very early adopted as one of greatest capacity, and as a shape which was not liable to distortion by pressure. It was set over an open fire, and the

## BOILER.

steam was confined until it was raised by the heat to the required pressure. But the open fire was wasteful of fuel, and the next step was to inclose the globular boiler in brickwork and conduct the flames in a flue winding round the boiler, in contact with it. The next form of boiler was the cylindrical, which stood upright like a bottle, the fire being placed at the bottom, and the flue winding round that part of the sides or walls of the boiler covered with water. For the sake of strength to resist the pressure of the steam, the bottom was hollowed or arched upwards, and it presented a concave dome to the radiant heat of the fire and the impact of the flames; and the top was made hemispherical. In process of time boilers of much larger size came to be required, and the horizontal wagon-shaped boiler of James Watt was produced, and was succeeded by the cylindrical boiler having hemispherical ends, in which simplicity and strength of design for higher pressures were combined. This boiler, shown in triplicate, D, D, D in fig. 1, is laid with a slight dip backwards, in order that the sludge which collects in the boiler may be deposited at the part furthest from the fire. Below the boiler at one end is placed the fire, the fireplace and the flues being inclosed by brickwork. The burning gases from the fire traverse the bottom of the boiler, beating directly upon its under horizontal surface, till it reaches the end furthest from the fire. The flame and hot gases then, in some examples, return along one side of the boiler, confined in the brick flue, and passing across in front of the end which is over the fire, traverse the other side of the boiler towards the chimney, which is entered by the gaseous current after having thus traversed the length of the boiler three times, and applied its heat successively to every point of the boiler that is covered with water. This is a boiler that does not require any stays, and is valuable where there is plenty of room.

But, for the sake of economy of fuel as well as of space, one or two cylindrical flues are commonly constructed within the boiler, as in fig. 4, showing the cylindrical shell constructed with flat ends, into which one flue-tube is fixed, traversing the boiler from end to end. The internal flue was first applied by James Watt. The burning gases from the fire, after having traversed the bottom of the boiler, return through the internal flue to the front, where the current is divided, and returns towards the chimney

along both sides of the boiler. In the Cornish boiler, similarly constructed, the internal tube is made sufficiently large to receive the furnace inside the boiler; the boiler being 'internally fired,' in contrast with the other boilers which have been described, and are 'under-fired.' When two large furnace-tubes for internal firing are applied within the boiler it is known as the Lancashire boiler, and is the most generally prevailing type of boiler for purposes on land.

The *shell* of the boiler, or outer part, is of iron or steel plates. The *steam chest* or *dome*, on the upper side of the boiler, is a reservoir, whence the steam is supplied to the engine by the *steam-pipe*, which is fitted with a *stop-valve*. The *furnace* is the chamber for the combustion of the fuel. The *flues* or conduits for the burnt gases are either *external* or *internal*; cylindrical metal flues are *flue-tubes*, and they are fixed at the ends into *tube-plates*. The *manhole* is the entrance to the boiler for inspection, &c.; and it is closed by a *manhole door* or *lid*. *Mudholes* are placed at or near the bottom of the boiler, for the discharge of sediment, &c. The water is supplied by the *feed-apparatus*; its level is indicated by a *float*. The *water-gauge* also shows the level of the water; it may be a *glass tube* at the front of the boiler, connected to it by two horizontal tubes, one at the upper end and one at the lower end of the glass tube; or it may be a series of two or three *gauge-cocks*, connected at different levels. The boiler is emptied by the *blow-off cock*; the surface of the water is cleared by the *scum-cock*. *Brine-pumps* may be used instead of blow-off cocks to draw off the brine from marine boilers. Surplus steam escapes by the *safety-valves*. *Vacuum valves* admit air into the boiler, when the pressure is less than that of the atmosphere. Fusible plugs are inserted in the boiler, over the fire, which melt and give vent to the steam when the pressure and temperature of the steam in the boiler become excessive and dangerous. The degree of pressure is indicated by the *pressure-gauge*. The boiler is strengthened by *stays*, which may consist of *rods*, *bolts*, or *gussets*. The boiler is covered with *clothing* or *cladding*. The *fire-grate* carries the fuel, and it consists of *grate-bars* or *fire-bars*, usually of cast-iron, supported by *cross-bearers* or *bar-frames*. The *mouthpiece* is the entrance to the furnace, and it rests on the *dead-plate*. The *fire-door* or *pair of fire-doors* are fitted to and hung by it. The

BOILER.

Figs. 1, 2, 3, Cylindrical Boilers with external flues.

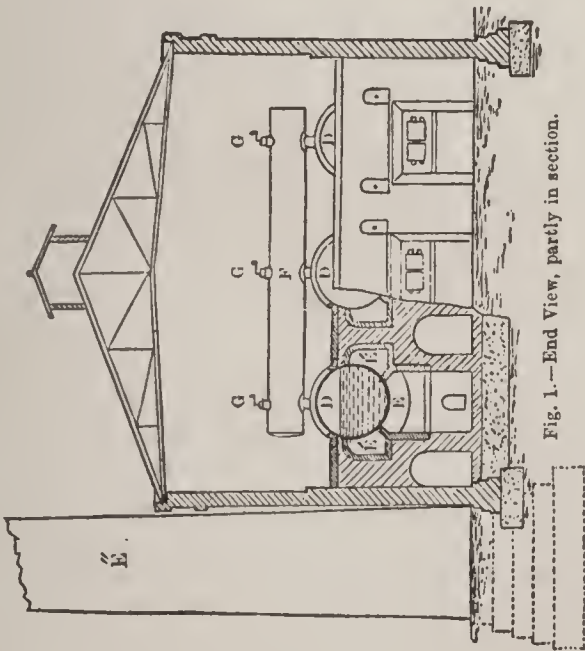

Fig. 1. - End View, partly in section.

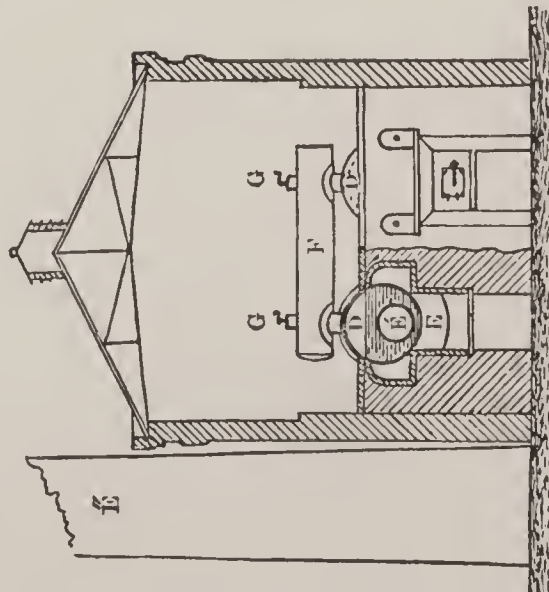

Fig. 4. - End View, partly in section.

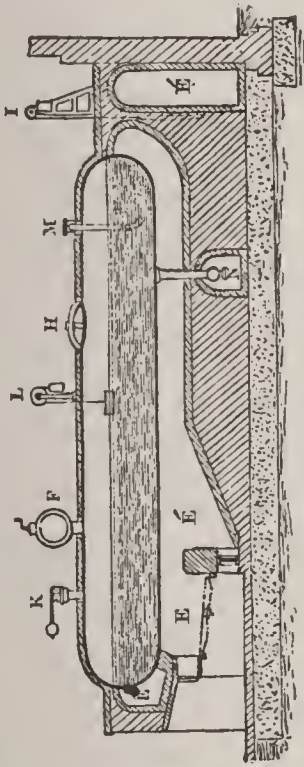

Fig. 2. - Longitudinal Section.

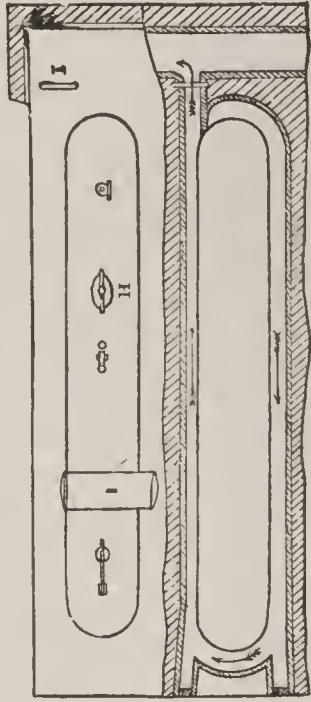

Fig. 3. - Section showing arrangement of the Flues.

Figs. 4, 5, 6, Cylindrical Boilers with internal flue.

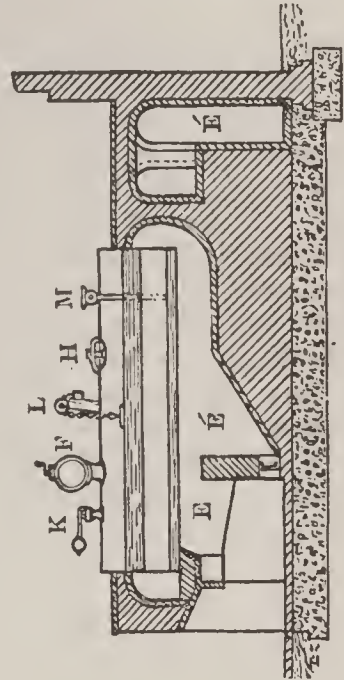

Fig. 5. - Longitudinal Section.

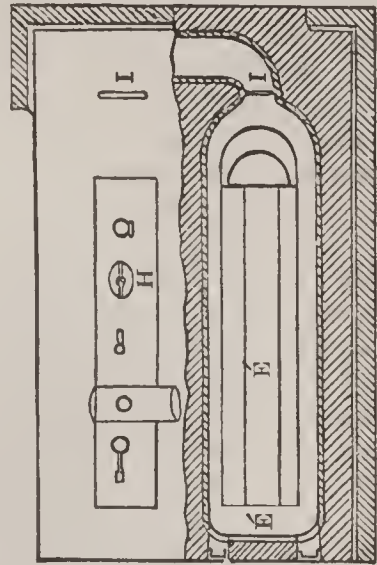

Fig. 6. - Section showing arrangement of the Flues.

- DD, Boilers.
- E, Furnace.
- E', Flues.
- E'', Chimney.
- F, Steam-receiver.
- GG, Stop-valves.
- H, Manhole.
- II, Dampers.
- K, Safety-valve
- L, Float.
- M, Feed-pipe.
- N, Blow-off tap.

These references are applicable to all the figures.

*heating surface* is the surface of the boiler exposed to the flame and burned gases from the furnace. The *boiler-room* or internal capacity of the boiler is divided into the *water-room*, occupied by water; and the *steam-room*, occupied by steam.

There are many varieties of boilers specially adapted to circumstances. The marine boiler is of the shape of a cheese, standing upright, containing the furnace-tubes in the lower part, and small flue-tubes—the multitubular flue—in the upper part. By inserting many small tubes in place of one or two large tubes, the body of water is subdivided, and the heat is effectively and rapidly distributed to the water. Locomotive boilers, also, are constructed with the multitubular flue, and the furnace or fire-box, surrounded with water, is placed at one end. There are many forms of upright or vertical boilers, consisting of upright cylindrical shells—containing a fire-box at the lower part, from which the burned gases are carried up through a single vertical flue, or the multitubular flue, to the chimney above. In another form of upright boiler, cross water-tubes are inserted in the upper part of the furnace, which absorb heat, both radiated and convected, and promote the circulation of the water in the boiler.

**Boiling**, BOILING-POINT. See *Boil*.

**Boiling-springs**. See *Geysers*.

**Bois de Boulogne** (bwä dè bö-lōn), a pleasant grove near the gates on the west of Paris, so named after the suburb Boulogne-sur-Seine. Its trees were more or less destroyed during the Franco-German war. It is still, however, one of the pleasantest Parisian holiday promenades and a famous duelling ground.

**Boisé City**, capital of State of Idaho, U.S. Pop. in 1890, 2311.

**Bois-le-duc** (bwä-lè-dük; Dutch '*S Her-togenbosch*), a fortified city, North Brabant, Holland, founded by Godfrey of Brabant in 1184, at the point where the Dommel and Aa unite to form the Diest; has manufactures of cloth, hats, cotton goods, &c., and a good trade in grain, its water traffic being equal to that of a considerable maritime port. The fortifications are of little modern value, but the surrounding country can be readily inundated at need. The cathedral is one of the finest in the Netherlands. Pop. 27,594. The Duke of York was defeated here by the French in 1794.

**Boisserée** (bwäs-rā) **Gallery**, a celebrated gallery of pictures in the Pinako-

thek or picture gallery at Munich, collected by the brothers Sulpice (1783–1854) and Melchior Boisserée. In 1827 King Ludwig of Bavaria purchased it for 120,000 thalers.

**Boissonade** (bwä-so-näd), JEAN FRANÇOIS, a French classical scholar, born 1774, died 1857. He became in 1809 assistant of Larcher as Greek professor of the Faculty of Letters in Paris, and four years afterwards he succeeded him both in the Faculty and in the Institute. In 1816 he was elected academician, and in 1828 was called to the chair of Greek literature in the College of France. Besides editing many of the minor classics, he issued a *Vitæ Sophistarum* (1822); *Syllogæ Poetarum Græcorum* (1823–26); *Anecdota Græca* (1829–44); &c.

**Boissy d'Anglas** (bwä-sē dāŋ-lä), FRANÇOIS ANTOINE, COMTE DE, a French statesman of the revolutionary period, born 1756, died 1826. In 1789 he was elected at Annonay to the states-general, and in 1792 to the Convention. He voted against the death of Louis XVI., and after the fall of Robespierre was appointed secretary of the Convention, and intrusted with the provisioning of Paris at a time of famine. He was made a member of the Council of Five Hundred in 1795, president of the Tribunate in 1803, senator and commander of the Legion of Honour in 1805, and a peer by Louis XVIII. in 1814. Besides many brochures, he wrote an essay on the life and writings of Malesherbes (1819–21); *Études Littéraires et Poétiques d'un Vieillard* (1825).

**Bojador'**, a cape on the west coast of Africa, one of the projecting points of the Sahara; till the fifteenth century the southern limit of African navigation. The coast of the Sahara from Cape Blanco to this cape and a considerable portion of the interior has been proclaimed Spanish territory.

**Bojar** (bo'yär). See *Boiar*.

**Bojardo** (bo-yär'dō). See *Boiardo*.

**Bojol** (bo-hol'), one of the Philippine Islands, north of Mindanao, about 40 m. by 30 m. Woody and mountainous. Pop. 187,000.

**Bokhara**, BOCHARA (bo-hä'ra), a khanate of Central Asia, vassal to Russia, bounded north by Russian Turkestan, west by Khiva and the Transcaspian Territory of Russia, south by Afghanistan, and east by Chinese Turkestan; area about 93,000 square miles. The country in the west is to a great extent occupied by deserts; in the east are numerous ranges of mountains. Cultivation is mainly confined to the valleys of the rivers,

the chief of which is the Oxus or Amoo Daria, forming the southern boundary and running close to the boundary on the west. The climate is warm in summer, but severe in winter; there is very little rain, and artificial irrigation is necessary. Besides cereals, cotton and tobacco are cultivated, and also a good deal of fruit. The total population, about 2,000,000, consists of the Usbek Tatars, who are the ruling race, and to whom the emir belongs; the Tajiks, who form the majority; Kirghiz, with Turcomans, Arabians, Persians, &c. The only two towns of importance are the capital, Bokhara, and Karshi. The capital, according to Vámbéry the centre of Tatar civilization, is behind the large towns of Western Asia in general luxury and comfort, though the country is distinguished from other countries of Central Asia by its numerous schools. The rule of the emir is theoretically absolute. The manufactures are unimportant, but there is a very considerable caravan trade, cotton, rice, silk, and indigo being exported, and woven goods, sugar, iron, &c., being imported. The trade will no doubt be greatly increased by the Russian Transcaspian railway, which crosses the country and reaches Samarkand.

Bokhara was the ancient Sogdiana or Maracanda, capital Samarkand; was conquered by the Arabs in the 8th century, by Genghis Khan in 1220, and by Timur in 1370, and was finally seized by the Usbeks in 1505. It has recently suffered much from the advances of the Russians, who, in 1868, compelled the cession of Samarkand and important tracts of territory. Since then the Emir Muzaffer-Eddin has sunk more and more into a position of dependency on Russia. After the Russian expedition to Khiva in 1873 an agreement was come to between Russia and Bokhara by which Bokhara received a portion of the territory ceded by Khiva to Russia, while the Russians received various privileges in return. The khanate will probably soon be completely under Russian administration, for what little power it had lapsed in 1884 on the annexation of Merv. Since 1885 the troops, formerly ill trained and badly armed, have been drilled by Russian instructors and armed with rifles.—BOKHARA, the capital of the khanate, is 8 or 9 miles in circuit, and surrounded by a mud wall. The streets are narrow and the houses poorly built; principal edifices: the palace of the khan, crowning a height near the centre of the town and

surrounded by a brick wall 70 feet high; and numerous mosques, schools, bazaars, and caravanserais. The trade was formerly large with India, but has been almost completely absorbed by Russia. Pop. 70,000.

**Bola'ma.** See *Bissagos*.

**Bolan' Pass,** a celebrated defile in the Hala Mountains, N.E. of Beluchistan, on the route between the Lower Indus (Scinde)



In the Bolan Pass.

and the table-land of Afghanistan. It is about 60 miles long, hemmed in on all sides by lofty precipices, and in parts so narrow that a regiment could defend it against an army. It is traversed by the Bolan river. The crest of the pass is 5800 feet high.

**Bolas** (that is, 'balls'), a form of missile used by the Paraguay Indians, the Patagonians, and especially by the Gauchos of the Argentine Republic. It consists of a rope or line having at either end a stone, ball of metal, or lump of hardened clay. When used it is swung round the head by one end, and then hurled at an animal so as to entangle it.

**Bolbec,** a town, France, dep. Seine-Inférieure, on the Bolbec. Chief products are printed cottons and handkerchiefs, linen and woollen stuffs, lace, &c. Pop. 11,575.

**Bolchow** (bol'hof). See *Bolkhoff*.

**Bole**, an earthy mineral occurring in amorphous masses, and composed chiefly of silica with alumina, iron, and occasionally magnesia. It is of a dull yellow, brownish, or red colour, has a greasy feel, and yields to the nail. In ancient times, under the name of Lemnian bole or earth, one variety of it had a place in the materia medica. At present the best known bole of commerce is a coarse pigment known as Berlin and English red.

**Boler'o**, a popular Spanish dance of the ballet class for couples, or for a single female dancer. The music, which is in triple measure, is generally marked by rapid changes of time, and the dancers mostly accompany the music with castanets. The interest of these dances largely depends upon the pantomime of passion, which forms an essential part of them.

**Bole'tus**, a genus of fungi, order Hymenomyces, family Polyporei. The characters of the genus are: broad, hemispherical cap, the lower surface formed of open tubes, cylindrical in form, and adhering to one another. The tubes can be separated from the cap, and contain little cylindrical capsules, which are the organs of reproduction. Most of the species are globulous. *Bolētus edūlis* has firm flesh and an agreeable nutty flavour, and is a considerable article of commerce in France, particularly around Bordeaux. Of the numerous other species of Boletus, many are edible, and one, *B. igniarius*, furnishes the German tinder, and is used as an external styptic.

**Boleyn** (bul'in), ANNE, second wife of Henry VIII. of England, eldest daughter of Sir Thomas Boleyn and Elizabeth Howard, daughter of the Duke of Norfolk; born, according to some accounts, in 1507, but more probably about 1501. She attended Mary, sister of Henry, on her marriage with Louis XII., to France, as lady of honour, returning to England about 1522, and becoming lady of honour to Queen Catherine. The king, who soon grew passionately enamoured of her, without waiting for the official completion of his divorce from Catherine, married Anne in January, 1533, having previously created her Marchioness of Pembroke. When her pregnancy revealed the secret, Cranmer declared the first marriage void and the second valid, and Anne was crowned at Westminster with unparalleled splendour. On Sept. 7, 1533, she became the mother of Elizabeth. She

was speedily, however, in turn supplanted by her own lady of honour, Jane Seymour. Suspicions of infidelity were alleged against her, and in 1536 the queen was brought before a jury of peers on a charge of treason and adultery. Smeaton, a musician, who was arrested



Anne Boleyn.

with others, confessed that he had enjoyed her favours, and on May 17 she was condemned to death. The clemency of Henry went no further than the substitution of the scaffold for the stake, and she was beheaded on May 19th, 1536. Whether she was guilty or not has never been decided; that she was exceedingly indiscreet is certain.

**Bolides** (bō'lidz), a name given to those meteoric stones or aerolites that explode on coming in contact with our atmosphere.

**Bo'lingbroke**, HENRY ST. JOHN, VISCOUNT, English statesman and political writer, born in 1678 at Battersea, London; educated at Eton and at Oxford, where he had a reputation both for ability and libertinism. In 1700 he married a considerable heiress, the daughter of Sir Henry Winchcomb, but they speedily separated. In 1701 he obtained a seat in the House of Commons, attaching himself to Harley and the Tories. He at once gained influence and became secretary of war in 1706, though he retired with the ministry in 1708. He continued, however, to maintain a constant intercourse with the queen, who preferred him to her other counsellors, and on the overthrow of the Whig ministry in 1710, after the Sacheverell episode, he became one of the secretaries of state. In 1712 he was called to the House of Lords by the



title of Viscount Bolingbroke, and in 1713, against much popular opposition, concluded the Peace of Utrecht. At this period the Tory leaders were intriguing to counteract the inevitable accession of power which the Whigs would receive under the House of Hanover; but shortly after the conclusion of the peace a contention fatal to the party broke out between the lord high-treasurer (Harley, Earl of Oxford) and Bolingbroke. Queen Anne, provoked by Oxford, dismissed him, and made Bolingbroke prime-minister, but died herself four days later. The Whig dukes at once assumed the power and proclaimed the elector king. Bolingbroke, dismissed by King George while yet in Germany, fled to France in March, 1715, to escape the inevitable impeachment by which, in the autumn of that year, he was deprived of his peerage and banished. James III., the *Pretender*, invited him to Lorraine and made him his secretary of state, but dismissed him in 1716 on a suspicion of treachery. He remained for some years longer in France, where (his first wife having died) he married the Marquise de Villette, niece of Madame de Maintenon, occupying himself with various studies. In 1723 he was permitted to return to England, living at first retired in the country in correspondence with Swift and Pope. He then joined the opposition to the Walpole ministry, which he attacked during eight years in the *Craftsman* and in pamphlets with such vigour and skill that in 1735 a return to France became prudent, if not necessary. In 1742, on the fall of Walpole, he came back in the expectation that his allies would admit him to some share of power; but, being disappointed in this respect, he withdrew entirely from politics and spent the last nine years of his life in quietude at Battersea, dying in 1751. He wrote an excellent and forcible style, his chief works being *A Dissertation upon Parties*; *Letters on the Spirit of Patriotism*, on the *Idea of a Patriot King*, and on the *State of Parties at the Accession of George I.*; *Letters on the Study of History* (containing attacks on Christianity), and other works. Pope was indebted to him for suggestions for his *Essay on Man*. He was clever and versatile, but unscrupulous and insincere.

**Bolivar** (bo-lé'vär), SIMON (*El Libertador*), the liberator of Spanish South America, was born at Caracas, July 24, 1783. He finished his education in Europe, and having then joined the patriotic party among

his countrymen he shared in the first unsuccessful efforts to throw off the Spanish yoke. In 1812 he joined the patriots of New Granada in their struggle, and having defeated the Spaniards in several actions he led a small force into his own country (Venezuela), and entered the capital, Caracas, as victor and liberator, Aug. 4, 1813. But the success of the revolutionary party was not of long duration. Bolivar was beaten by General Boves, and before the end of the year the royalists were again masters of Venezuela. Bolivar next received from the Congress of New Granada the command of an expedition against Bogotá, and after the successful transfer of the seat of government to that city retired to Jamaica. Having again returned to Venezuela he was able to rout the royalists under Morillo, and, after a brilliant campaign, effected in 1819 a junction with the forces of the New Granada republic. The battle of Bojaca which followed gave him possession of Santa Fé and all New Granada, of which he was appointed president and captain-general. A law was now passed by which the Republics of Venezuela and New Granada were to be united in a single state, as the *Republic of Colombia*, and Bolivar was elected the first president. In 1822 he went to the aid of Peru, and was made dictator, an office held by him till 1825, by which time the country had been completely freed from Spanish rule. In 1825 he visited Upper Peru, which formed itself into an independent republic named *Bolivia*, in honour of Bolivar. In Colombia a civil war arose between his adherents and the faction opposed to him, but Bolivar was confirmed in the presidency in 1826, and again in 1828, and continued to exercise the chief authority until May, 1830, when he resigned. He died at Carthagena on the 17th December, 1830. — One of the states or departments of Colombia is named after him Bolivar. Its area is 21,345 sq. miles; its pop. 324,400. Capital Carthagena.

**Bolivia**, formerly called UPPER PERU, a republic of South America, bounded N. and E. by Brazil, S. by the Argentine Republic and Paraguay, and W. by Peru and Chile. Its area, according to estimates in 1888, is 567,360 sq. miles. As a result of the recent war with Chile, Bolivia ceded to that country her coast territory, covering about 29,000 square miles, with a population of 22,000. The total pop. is 1,192,162. An unascertained proportion of the inhabitants belong

## BOLIVIA.

to aboriginal races (the Aymaras and the Quichuas); the larger portion of the remainder being Mestizos or descendants of the original settlers by native women. The largest town is La Paz, but the executive government has its seat at Sucre or Chuquisaca; other towns are Potosi, Oruro, and Cochabamba. The broadest part of the Andes, where these mountains, encompassing Lakes Titicaca (partly in Bolivia) and Aullagas, divide into two chains, known as the Eastern and Western Cordilleras, lies in the western



Costumes of Aymarus and Quichuas.

portion of the state. Here are some of the highest summits of the Andes, as Sorata, Illimani, and Sajama. The two chains inclose an extensive table-land, the general elevation of which is about 12,500 ft., much of it being saline and barren, especially in the south. The ramifications of the eastern branch extend a long way from the Cordillera, forming numerous valleys which pour their waters into the Pilcomayo, an affluent of the Paraguay, and into the Mamore, Beni, and other great affluents of the Amazon. These spurs of the Eastern Cordillera are succeeded by great plains, in parts annually flooded to such a degree by the numerous rivers running through them, that communication by boat is practicable for long stretches. In the south-east there is an extensive barren region with salt marshes. The waters of Lake Titicaca are conveyed to Lake Aullagas by the Desaguadero; the latter lake (which is salt) has only an insignificant outlet.

The climate, though ranging between extremes of heat and cold, is very healthy, and cholera and yellow fever are unknown.

The elevated regions are cold and dry, the middle temperate and delightful, the lower valleys and plains quite tropical. Among animals are the llama, alpaca, vicuña, chinchilla, &c.; the largest bird is the condor. Bolivia has long been famed for its mineral wealth, especially silver and gold, the total value of these metals produced between 1545 and 1875 being estimated at nearly \$2,000,000,000. The silver produce in 1890 was estimated at \$11,122,610. The celebrated Potosi was once the richest silver district in the world. The country is capable of producing every product known to South America, but cultivation is in a very backward state. Coffee, coca, cacao, tobacco, maize, and sugar-cane are grown, and there is an inexhaustible supply of india-rubber. The imports and exports are roughly estimated at about \$6,000,000 and \$9,000,000 respectively. The chief exports are silver (two-thirds of the whole), cinchona or Peruvian bark, cocoa, coffee, caoutchouc, alpaca wool, copper, tin, and other ores. Roads are few and bad; and until these are improved and extended, railways built (there is one short line connecting La Paz with Titicaca and thus with the Peruvian Puno-Islay line), and the water communication by way of the Amazon and its tributaries taken advantage of, the trade must remain small. Accounts are kept in *bolivianos* or **dollars**, value about 83 cts.

By its constitution Bolivia is a democratic republic. The executive power is in the hands of a president elected for four years, and the legislative belongs to a congress of two chambers, both elected by universal suffrage. The finances are in a disorganized state; the revenue may amount to \$3,500,000. The debt (1891) was \$5,072,121. The religion is the Roman Catholic, and public worship according to the rites of any other church is prohibited. Education is at an exceedingly low ebb.

Bolivia under the Spaniards long formed part of the viceroyalty of Peru, latterly it was joined to that of La Plata or Buenos Ayres. Its independent history commences with the year 1825, when the republic was founded. The constitution was drawn up by Bolivar, in whose honour the state was named Bolivia; and was adopted by Congress in 1826. It has since undergone important modifications. But the country has been almost continually distracted by internal and external troubles, and can scarcely be said to have had any definite constitu-

tion. It suffered severely in the war which, with Peru, it waged against Chile in 1879 and subsequent years, and which ended in the loss of territory already mentioned; and also from a continued state of anarchy since the close of that war.

**Bolkhoff** (*bol'hof*), an ancient town of Russia, gov. of Orel; the industries embrace leather and hemp, hosiery, tallow, gloves, soap. Pop. 26,395.

**Boll** (*bōl*), a Scotch measure for corn, varying in different districts and for different articles. A boll of wheat or beans is equal to 4 bushels, a boll of oats, barley, and potatoes to 6 bushels.

**Bol'landists**, the society of Jesuits which published the *Acta Sanctorum*, a collection of lives of the saints of the Roman Catholic Church. They received this name from John Bolland (d. 1665), who edited the first five volumes from materials already accumulated by Heribert Rosweyd, a Flemish Jesuit (d. 1629). The society was first established at Antwerp, removed to Brussels on the abolition of the society of Jesuits in 1773, and dispersed in 1794. A new association was formed in 1837 under the patronage of the Belgian government, and the publication of the *Acta Sanctorum* has been continued.

**Bologna** (*bo-lōn'yà*), one of the oldest, largest, and richest cities of Italy, capital of the province of same name, in a fertile plain at the foot of the Apennines, between the rivers Reno and Savena, surrounded by an unfortified brick wall. It is the see of an archbishop, and has extensive manufactures of silk goods, velvet, artificial flowers, &c. The older quarters are poorly, and the modern handsomely built. There are colonnades along the sides of the streets affording shade and shelter to the foot-passengers. Among the principal buildings are the Palazzo Pubblico, which contains some magnificent halls adorned with statues and paintings; the Palazzo del Podestà; and the church or basilica of St. Petronio. Among the hundred other churches, S. Pietro, S. Salvatore, S. Domenico, S. Giovanni in Monte, S. Giacomo Maggiore, all possess rich treasures of art. The leaning towers Degli Asinelli and Garisenda, dating from the 12th century, are among the most remarkable objects in the city; and the market is adorned with the colossal bronze Neptune of Giovanni da Bologna. An arcade of 640 arches leads to the church of Madonna di S. Lucca, situated at the foot of the Apennines,

near Bologna, and the resort of pilgrims from all parts of Italy. Bologna has long been renowned for its university, claiming to have been founded in 1088, and having a library, at one time in the care of Cardinal Mezzofanti, which numbers over 200,000 volumes and 9000 MSS. The Istituto delle Scienze has a library which numbers about 160,000 volumes, with 6000

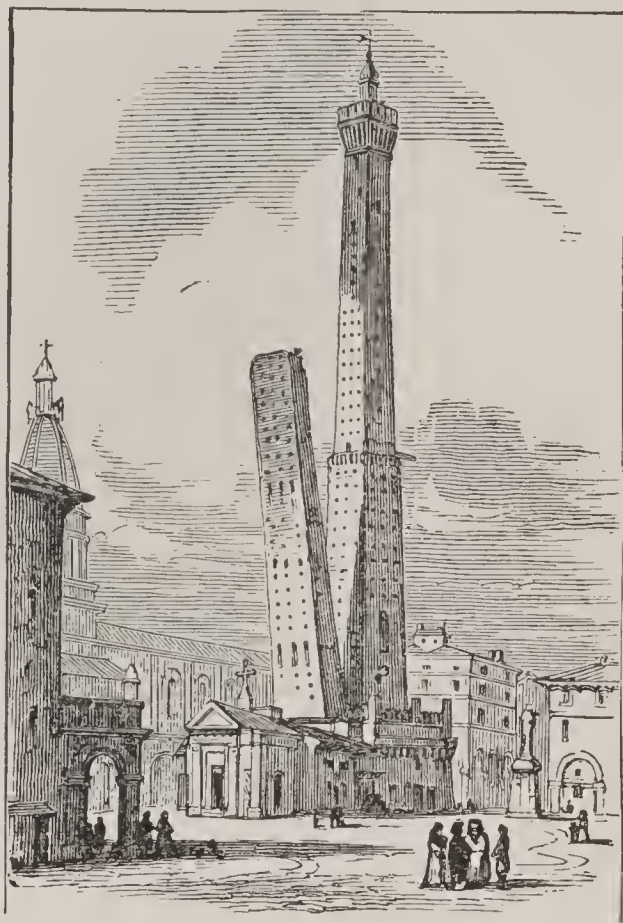

The Asinelli and Garisenda Towers, Bologna.

manuscripts. The Church of San Domenico has a library of 120,000 volumes. The Academy of Fine Arts has a rich collection of paintings by native artists, such as Francia, and the later Bolognese school, of which the Caraccis, Guido Reni, Domenichino, and Albano were the founders.—Bologna was founded by the Etruscans under the name of *Felsina*; became in 189 B.C. the Roman colony *Bononia*; was taken by the Longobards about 728 A.D.; passed into the hands of the Franks, and was made a free city by Charlemagne. In the 12th and 13th centuries it was one of the most flourishing of the Italian republics; but the feuds between the different parties of the nobles led to its submission to the papal see in 1513. Several attempts were made to throw off the papal yoke, one of which, in 1831, was for

a time successful. In 1849 the Austrians obtained possession of it. In 1860 it was annexed to the dominions of King Victor Emmanuel. Pop. 103,998.—The province of BOLOGNA, formerly included in the papal territories, forms a rich and beautiful tract; area 1390 sq. miles; pop. 1891, 484,135.

**Bologna**, GIOVANNI (prop. *Jean Boulogne*), sculptor and architect, born at Douay 1524, studied at Rome, and passed most of his life at Florence, where he died in 1608. Chief works: a marble Rape of the Sabines, and a bronze Mercury.

**Bologna phial**, a small flask of unannealed glass, which flies into pieces when its surface is scratched by a hard body.

**Bologna stone**, a name for a variety of heavy-spar or sulphate of barytes.

**Bolom'eter**, a most sensitive electrical instrument invented by Langley in 1883 for the measurement of radiant heat.

**Bolor-Tagh**, also BILAU, or BELUT TAGH, a mountain range formerly imagined to exist in Central Asia between Eastern and Western Turkestan as the axis of the continent. At that point, however, there is really a lofty table-land called the Pamir.

**Bolse'na** (ancient *Volsinii*, one of the twelve Etruscan cities), a walled town, Italy, province of Rome, on the N. side of a lake of the same name. The district yields a good wine. Pop. 2100.—The lake (ancient *Lacus Volsiniensis*) is 9 miles long, 7 miles broad, and 1000 feet above sea-level, and is well stocked with fish.

**Bolsward** (bol'svärd), an old town of Holland, province of Friesland, at the junction of several canals, and having one of the largest and finest parish churches in Friesland. Pop. 5939.

**Bolton**, or BOLTON-LE-MOORS, a large manufacturing town and municipal and parliamentary borough of Lancashire, England, lying 10 miles N.W. from Manchester, and consisting mainly of two divisions, Great Bolton and Little Bolton, separated from each other by the river Croal. The town, which is of considerable antiquity, received its charter in 1256, and became a manufacturing town as early as 1337, when there was an immigration of Flemings; but its main growth has been of comparatively recent date, and in large part due to the inventions of its sometime residents Arkwright and Crompton. In manufacturing industries it is now surpassed by few places in Britain, and it contains some of the largest and finest cotton-mills in the world;

the yarns spun being generally fine, and a great variety of fancy goods being produced, besides plain calicoes; while bleaching is also largely carried on. There are large engineering works, besides collieries, paper-mills, foundries, chemical works, &c. Among the public buildings are one of the finest market-halls in England; a mechanics' institution, a noble building in the Romanesque style; the Chadwick Museum; and a town-hall, in the Grecian style, with a tower 220 feet high, fronting the spacious market-square. The free grammar-school of the town, founded in 1641, has two university exhibitions of £60 a year each. The Bolton Free Public Library, opened in 1853, contains about 50,000 vols. There are two parks and three recreation grounds. Bolton returns two members to parliament. Pop. 1891, 115,002.

**Bolt-ropes**, ropes used to strengthen the sails of a ship, the edges of the sails being sewn to them. Those on the sides are called *leech-ropes*, the others *head* and *foot ropes*.

**Bo'lus**, a soft round mass of some medicinal substance larger than a pill, intended to be swallowed at once.

**Boma**, a trading station on the right bank of the lower Congo, and seat of government of the Congo State.

**Bomarsund'**, a Russian fortress on the Aland Islands at the entrance of the Gulf of Bothnia, bombarded and forced to capitulate to the allied French and English in 1854 during the Crimean war, and then destroyed.

**Bomb** (bom), a large, hollow iron ball or shell, filled with explosive material and fired from a mortar. The charge in the bomb is exploded by means of a fuse filled with powder and other inflammable materials, which are ignited by the discharge of the mortar. Conical shells shot from rifled cannon have largely supplanted the older bomb. The use of bombs and mortars is said to have been invented in the middle of the 15th century.

**Bomba**, a nickname given to Ferdinand II. of Naples, on account of his bombardment of Messina in 1848.

**Bom'bard**, a kind of cannon or mortar formerly in use, generally loaded with stone instead of iron balls. Hence the term *bombardier*.

**Bombardier** (-dēr'), an artillery soldier whose special duties are connected with the loading and firing of shells, grenades, &c., from mortars or howitzers. See *Bombard*.

## BOMBARDIER BEETLE — BOMBAY.

**Bombardier Beetle**, a name given to beetles of the genera *Brachinus* and *Ap-tinus*, family Carabidæ, because of the remarkable power they possess of being able to defend themselves by expelling from the anus a pungent acrid fluid, which explodes with a pretty loud report on coming in contact with the air.

**Bombardment**, an attack with bombs or shells upon a fortress, town, or any position held by an enemy, generally carried out from the sea.

**Bombar'don**, a large musical instrument of the trumpet kind, in tone not unlike an ophicleide. Its compass is from F on the fourth ledger-line below the bass-staff to the lower D of the treble-staff. It is not capable of rapid execution.



Bombardon.

**Bombasin.** See *Bombazine*.

**Bombax.** See *Silk-cotton Tree*.

**Bombay'** (Portuguese 'good harbour'), chief seaport on the west coast of India, and capital of the presidency of the same name, stands at the southern extremity of the island of Bombay, and is divided into two portions, one known as the Fort, and formerly surrounded with fortifications, on a narrow point of land with the harbour on the east side and Back Bay on the west; the other known as the City, a little to the north-west. In the Fort are Bombay Castle, the government offices, and almost all the merchants' warehouses and offices; but most of the European residents live outside of the mercantile and native quarters of the town in villas or bungalows. Bombay has many handsome buildings, both public and private, as the cathedral, the university, the secretariat, the new high court, the post and telegraph offices, &c. Various industries, such as dyeing, tanning, and metal working, are carried on, and there are large cotton factories. The commerce is very extensive, exports and imports of merchandise reaching a total value of over £60,000,000 annually. The harbour is one

of the largest and safest in India, and there are commodious docks. There is a large traffic with steam-vessels between Bombay and Great Britain, and regular steam communication with China, Australia, Singapore, Mauritius, &c. The island of Bombay, which is about 11 miles long and 3 miles broad, was formerly liable to be overflowed by the sea, to prevent which substantial walls and embankments have been constructed. The harbour is protected by formidable rock-batteries. After Madras, Bombay is the oldest of the British possessions in the East, having been ceded by the Portuguese in 1661. Pop. 1891, 821,769.

**Bombay'**, one of the three presidencies of British India, between lat. 14° and 29° N., and lon. 66° and 77° E. It stretches along the west of the Indian peninsula, and is irregular in its outline and surface, presenting mountainous tracts, low barren hills, valleys, and high table-lands. It is divided into a northern, a central, and a southern division, the Sind division, and the town and island of Bombay. The northern division contains the districts of Ahmedabad, Kaira, Panch Mahals, Broach, Surat, Thana, Kolába; the Central Khandesh, Nasik, Ahmednagar, Poona, Sholapur, Satara; the southern, Belgaum,

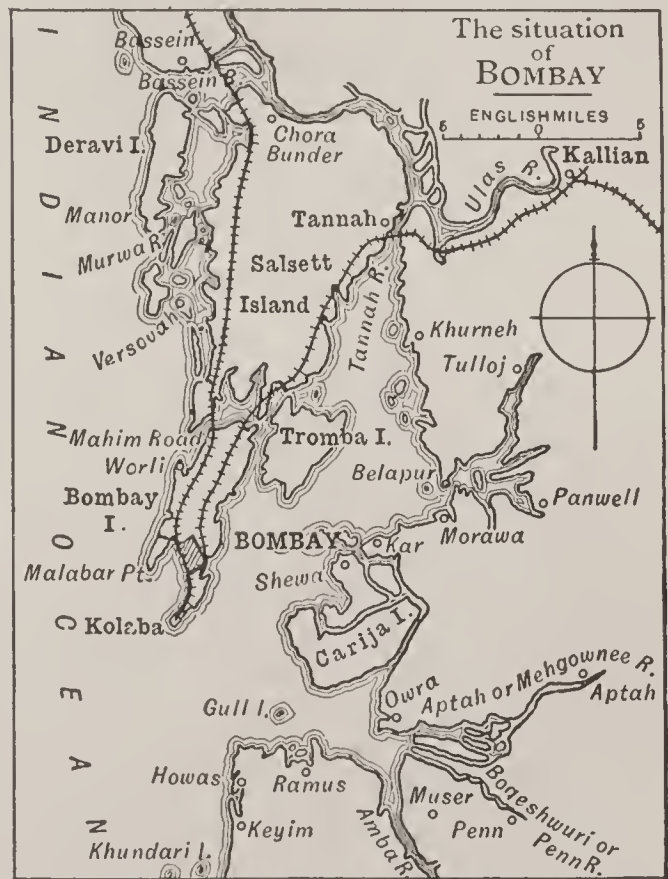

Dharwar, Kaladgi, Kanara, Ratnagiri. Total area, 124,192 sq. m.; pop. 1891, 18,901,123,

including the city and territory of Aden in Arabia, 70 sq. miles (pop. 44,079). The native or feudatory states connected with the presidency (the chief being Kathiawar) have an area of 69,045 sq. m. and a pop. of 8,059,298. The Portuguese possessions Goa, Damán, and Diu geographically belong to it. Many parts, the valleys in particular, are fertile and highly cultivated; other districts are being gradually developed by the construction of roads and railroads. The southern portions are well supplied with moisture, but great part of Sind is the most arid portion of India. The climate varies, being unhealthy in the capital Bombay and its vicinity, but at other places, such as Poonah, very favorable to Europeans. In 1896-97-98 the bubonic pestilence broke out and destroyed thousands of the natives. The chief productions of the soil are cotton, rice, millet, wheat, barley, dates, and the cocoa-palm. The manufactures are cotton, silk, leather, &c. The great export is cotton. In 1892 the imports were 367,765,560 rupees; exports, 433,071,130 rupees. The administration is in the hands of a governor and council. The revenue and expenditure each amount to about £10,000,000 annually. The chief source of revenue is the land, which is largely held on the ryotwar system.

**Bombazine** (-zēn') is a mixed tissue of silk and worsted, the first forming the warp and the second the weft. It is fine and light in the make, and may be of any colour, though black is now most in use.

**Bomb-ketch**, a kind of vessel formerly built for the use of mortars at sea in a bombardment. Bomb-ketches were usually of 100 to 150 tons burden, about 70 feet long, and had two masts. They were built very strong to sustain the violent shock produced by the discharge of the mortars, of which they generally carried two.

**Bomb-shell.** See *Shell*.

**Bom'byx**, the genus of moths to which the silk-worm moth (*B. mori*) belongs.

**Bona**, seaport and fortified city of Algeria, with manufactures of burnouses, tapestry, and saddles, and a considerable trade. Pop. 22,000.

**Bona Fides**, BONA FIDE (fi'dēz, fi'dē; Lat. 'good faith,' 'in good faith'), a term derived from the Roman jurists, implying the absence of all fraud or unfair dealing. A *bona fide* traveller in England and Scotland is one who actually travels three miles or more from home on Sunday and is therefore legally entitled to demand and obtain

alcoholic refreshments at a hotel. In the law of Scotland a *bona fide* possessor is a person who holds property upon a title which he honestly believes to be good.

**Bonan'za** (Sp. 'fair weather,' 'a favouring wind'), a term applied in the United States to an abundance of precious metal or rich ore in a mine.

**Bonaparte** (bon'a-pärt), the French form which the great Napoleon was the first to give to the original Italian name *Buonaparte*, borne by his family in Corsica. As early as the 12th and 13th centuries there were families of this name in Northern Italy, members of which reached some distinction as governors of cities (*podestà*), envoys, &c. But the connection between the Corsican Bonapartes and these Italian families is not clearly established, though probably the former descended from a Genoese branch of the family, which transplanted itself about the beginning of the 16th century to Corsica, an island then under the jurisdiction of Genoa. From that time the Buonapartes ranked as a distinguished patrician family of Ajaccio. About the middle of the 18th century there remained three male representatives of this family at Ajaccio, viz. the archdeacon Luciano Bonaparte, his brother Napoleon, and the nephew of both, Carlo, the father of the Emperor Napoleon I. Carlo or Charles Buonaparte, born 1746, studied law at Pisa University, and on his return to Corsica married Letizia Ramolino. He fought under Paoli for the independence of Corsica, but when further resistance was useless he went over to the side of the French, and was included by Louis XV. amongst the 400 Corsican families who were to have rights in France as noble. In 1777 he went to Paris, where he resided for several years, procuring a free admission for his second son Napoleon to the military school of Brienne. He died in 1785 at Montpellier. By his marriage with Letizia Ramolino he left eight children: Giuseppe, or Joseph (see below), king of Spain; Napoleon I., emperor of the French (see *Napoleon I.*); Lucien (see below), prince of Canino; Maria Anna, afterwards called Élise, princess of Lucca and Piombino, and wife of Prince Bacciocchi (see *Bacciocchi*); Luigi, or Louis (see below), king of Holland; Carlotta, afterwards named Marie Pauline, princess Borghese (see *Borghese*); Annunziata, afterwards called Caroline, wife of Murat (see *Murat*), king of Naples; and Girolamo, or Jerome (see below), king of Westphalia.

## BONAPARTE.

**Bonaparte, JEROME**, youngest brother of Napoleon I., was born at Ajaccio in 1784, and at an early age entered the French navy as a midshipman. In 1801 he was sent out on an expedition to the West Indies, but the vessel being chased by English cruisers, was obliged to put in to New York. During his sojourn in America Jerome Bonaparte became acquainted with Miss Elizabeth Patterson, the daughter of the president of the Bank of Baltimore, and though still a minor, married her in spite of the protests of the French consul on 24th December, 1803. The emperor, his brother, whose ambitious views were thwarted by this marriage, after an ineffectual application to Pope Pius VII. to have it dissolved, issued a decree declaring it to be null and void. After considerable services both in the army and navy, in 1807 he was created King of Westphalia, and married Catherine Sophia, princess of Würtemberg. His government was not wise or prudent, and his extravagance and his brother's increasing exactions nearly brought the state to financial ruin. The battle of Leipzig put an end to Jerome's reign, and he was obliged to take flight to Paris. He remained faithful to his brother through all the events that followed till the final overthrow at Waterloo. After that, under the title of the Comte de Montfort, he resided in different cities of Europe, but latterly chiefly at Florence. After the election of his nephew, Louis Napoleon, to the presidentship of the French Republic, in 1848, he became successively governor-general of Les Invalides, a marshal of France, and president of the senate. He died in 1860. From his union with Miss Patterson only one son proceeded, Jerome, who was brought up in America, and married a lady of that country, by whom he had a son, who served as an officer in the French army during the Crimean war. The offspring of this marriage has not, however, been recognized as legitimate by the French tribunals. Of Jerome Bonaparte's second marriage two children remain, Prince Napoleon Joseph, who assumed the name of Jerome, and the Princess Mathilde. From the marriage of Prince Napoleon, well known by the nickname 'Plon-Plon,' with Clotilde, daughter of King Victor Emmanuel of Italy, were born three children—Victor (born 18th July, 1862), Louis, and Marie, the first of whom since the death of Napoleon III.'s son, the Prince Imperial, is generally recognized by the

Bonapartist party as the heir to the traditions of the dynasty. Both had to leave France in 1886, a law being passed expelling pretenders to the French throne and their eldest sons.

**Bonaparte, JOSEPH**, the eldest brother of Napoleon I., was born in Corsica in 1768, educated in France at the College of Autun, returned to Corsica in 1785, on his father's death, studied law, and in 1792 became a member of the new administration of Corsica under Paoli. In 1793 he emigrated to Marseilles, and married the daughter of a wealthy banker named Clari. In 1796, with the rise of his brother to fame after the brilliant campaign of Italy, Joseph began a varied diplomatic and military career. At length, in 1806, Napoleon, having himself assumed the imperial title in 1804, made Joseph King of Naples, and two years afterwards transferred him to Madrid as King of Spain. His position here, entirely dependent on the support of French armies, became almost intolerable. He was twice driven from his capital by the approach of hostile armies, and the third time, in 1813, he fled, not to return. After Waterloo he went to the United States, and lived for a time near Philadelphia, assuming the title of Count de Survilliers. He subsequently came to England, finally repaired to Italy, and died at Florence in 1844.

**Bonaparte, LETIZIA RAMOLINO**, the mother of Napoleon I., and, after Napoleon's assumption of the imperial crown, dignified with the title of Madame Mère, was born at Ajaccio in 1750, and was married in 1767 to Charles Buonaparte. She was a woman of much beauty, intellect, and force of character. Left a widow in 1785, she resided in Corsica till her son became first consul, when an establishment was assigned to her at Paris. On the fall of Napoleon she retired to Rome, where she died in 1836.

**Bonaparte, LOUIS**, second younger brother of the Emperor Napoleon I., and father of Napoleon III., was born in Corsica in 1778. He was educated in the artillery school at Chalons, accompanied Napoleon to Italy and Egypt, and subsequently rose to the rank of a brigadier-general. In 1802 he married Hortense Beauharnais, Josephine's daughter, and in 1806 was compelled by his brother to accept, very reluctantly, the Dutch crown. He exerted himself in promoting the welfare of his new subjects, and resisted as far as in him lay the tyrannical inter-

ference and arbitrary procedure of France; but disagreeing with his brother in regard to some measures of the latter, he abdicated in 1810 and retired to Grätz under the title of the Count of St. Leu. He died at Leghorn in 1846. He was the author of several works which show considerable literary ability.

**Bonaparte, LUCIEN**, Prince of Canino, next younger brother of Napoleon I., was born at Ajaccio in 1775. He emigrated to Marseilles in 1793, and having been appointed to a situation in the commissariat at the small town of St. Maximin in Provence, he married the innkeeper's daughter. Here he distinguished himself as a republican orator and politician, and was so active on this side that after Robespierre's fall he was in some danger of suffering as a partisan. His brother's influence, however, operated in his favour, and in 1798 we find him settled in Paris and a member of the newly-elected Council of Five Hundred. Shortly after Napoleon's return from Egypt in 1799 he was elected President of the Council, in which position he contributed greatly to the fall of the Directory and the establishment of his brother's power, on the famous 18th Brumaire (9th Nov.). Next year, as Napoleon began to develop his system of military despotism, Lucien, who still held to his republican principles and candidly expressed his disapproval of his brother's conduct, fell into disfavour and was sent out of the way as ambassador to Spain. Eventually, when Napoleon had the consulate declared hereditary, Lucien withdrew to Italy, settling finally at Rome, where he devoted himself to the arts and sciences, and lived in apparent indifference to the growth of his brother's power. In vain Napoleon offered him the crown, first of Italy and then of Spain; but he came to France and exerted himself on his brother's behalf, both before and after Waterloo. Returning to Italy, he spent the rest of his life in literary and scientific researches, dying in 1840. Pope Pius VII. made him Prince of Canino. He was the author of several works, amongst which are two long poems. His eldest son, Charles Lucien Laurent Bonaparte, born in 1803, achieved a considerable reputation as a naturalist, chiefly in ornithology. He published a continuation of Wilson's Ornithology; *Iconografia della Fauna Italica*; *Conspectus Generum Avium*, &c. He died in 1857. Another son, Pierre (1815-81) led an unsettled and disreputable life, and be-

came notorious in 1870 by killing, in his own house at Paris, the journalist Victor Noir, who had brought him a challenge. He got off on the plea of self-defence, but had to leave France.

**Bonas'sus**, a species of wild ox, the aurochs.

**Bonaventure, St.**, otherwise John of Fidanza, one of the most renowned scholastic philosophers, was born in 1221 in the Papal States; became in 1243 a Franciscan monk; in 1253 teacher of theology at Paris, where he had studied, in 1256 general of his order, which he ruled with a prudent mixture of gentleness and firmness. In 1273 Gregory X. made him a cardinal, and he died in 1274 while papal legate at the Council of Lyons. He was canonized in 1482 by Sixtus IV. His writings are elevated in thought and full of a fine mysticism, a combination which procured him the name of *Doctor Seraphicus*. He wrote on all the philosophical and theological topics of the time with authority, but best, perhaps, on those that touch the heart and imagination. Among his writings are *Itinerarium Mentis in Deum*, *Reductio Artium in Theologiam*; *Centiloquium*; and *Breviloquium*.

**Bond**, an obligation in writing to pay a sum of money, or to do or not to do some particular thing specified in the bond. The person who gives the bond is called the obligor, the person receiving the bond is called the obligee. A bond stipulating either to do something wrong in itself or forbidden by law, or to omit the doing of something which is a duty, is void. No person who cannot legally enter into a contract, such as an infant or a lunatic, can become an obligor, though such a person may become an obligee. No particular form of words is essential to the validity of a bond. A common form of bond is that on which money is lent to some company or corporation, and by which the borrowers are bound to pay the lender a certain rate of interest for the money. Goods liable to customs or excise duties are said to be *in bond* when they are temporarily placed in vaults or warehouses under a bond by the importer or owner that they will not be removed till the duty is paid on them. Such warehouses are called *bonded* warehouses (stores, &c.).

**Bondage.** See *Villénage*.

**Bonded Goods.** See *Bond*.

**Bondu, Bondou** (bon'dö), a country of Senegambia, West Africa, the centre being



in about lat. 14° N., lon. 12° 30' W. It has a luxuriant vegetation, magnificent forests, and is in many parts under good culture, producing large crops of cotton, millet, maize, indigo, tobacco, &c. The inhabitants are Foulahs. It is governed by a king, but is now under French control.

**Bone**, a hard material constituting the framework of mammalia, birds, fishes, and reptiles, and thus protecting vital organs such as the heart and lungs from external pressure and injury. In the fetus the bones are formed of cartilaginous (gristly) substance, in different points of which earthy matter—phosphates and carbonates of lime—is gradually deposited till at the time of birth the bone is partially formed. After birth the formation of bone continues, and, in the temperate zones, they reach their perfection in men between the ages of twenty and twenty-five. From this age till fifty they change but slightly; after that period they grow thinner, lighter, and more brittle. Bones are densest at the surface, which is covered by a firm membrane called the *periosteum*; the internal parts are more cellular, the spaces being filled with marrow, a fatty tissue, supporting fine blood-vessels. Bone consists of nearly 34 per cent organic material and of 66 per cent inorganic substances, chiefly phosphate, carbonate, and fluoride of lime, and phosphate of magnesium. The organic material is converted into gelatine by boiling. It is this which makes bones useful for yielding stock for soup. The inorganic substances may be dissolved out by steeping the bone in dilute hydrochloric acid. Bones, from the quantity of phosphates they contain, make excellent manure. See *Bone Manure*.

**Bone-ash**, BONE-EARTH, the earthy or mineral residue of bones that have been calcined so as to destroy the animal matter and carbon. It is composed chiefly of phosphate of lime, and is used for making cupels in assaying, &c.

**Bone-bed**, in geol. a bed containing numerous fragments of fossil bones, teeth, &c., as in the Rhætic formation in the south-west of England and the Ludlow bone-bed in the Silurian formation.

**Bone Black**, IVORY BLACK, or ANIMAL CHARCOAL, is obtained by heating bones in close retorts till they are reduced to small coarse grains of a black carbonaceous substance. This possesses the valuable property of arresting and absorbing into itself the colouring matter of liquids which are passed

through it. Hence it is extensively used in the process of sugar-refining, when cylinders of large dimensions filled with this substance are used as filters. After a certain amount of absorption the charcoal becomes saturated and ceases to act. It has then to be restored by reheating or other methods. Bone black has also the property of absorbing odours, and may thus serve as a disinfectant of clothing, apartments, &c.

**Bone-breccia** (-brech'i-a), in geology, a conglomerate of fragments of bones and limestone, cemented into a solid mass of rock by calcareous matter, found in certain caverns in Derbyshire, Germany, &c.

**Bone-caves**, caverns containing deposits in which are embedded large quantities of the bones of animals (many of them extinct), dating from the Pleiocene or later geologic periods.

**Bone-dust**, bones ground to dust to be used as manure. See *Bone Manure*.

**Bone Manure**, one of the most important fertilizers in agriculture. The value of bones as manure arises chiefly from the phosphates and nitrogenous organic matters they contain; and where the soil is already rich in phosphates bone is of little use as manure. It is of most service therefore where the soil is deficient in this respect, or in the case of crops whose rapid growth or small roots do not enable them to extract a sufficient supply of phosphate from the earth, turnips, for instance, or late-sown oats and barley. There are several methods for increasing the value of bones as manure, by boiling out the fat and gelatine, for instance, the removal of which makes the bones more readily acted on by the weather and hastens the decay and distribution of their parts, or by grinding them to dust or dissolving them in sulphuric acid, by which latter course the phosphates are rendered soluble in water. Bones have long been used as manure in some parts of England, but only in a rude, unscientific way. It was in 1814 or 1815 that machinery was first used for crushing them in Yorkshire and Lincolnshire, and bone-dust and dissolved bones are now largely employed as manures, great quantities of bones being now imported into Great Britain for this purpose. Before being utilized in agriculture they are often boiled for the oil or fat they contain, which is used in the manufacture of soap and lubricants.

**Boneset**, or THOROUGHWORT (*Eupatorium perfoliātum*), a useful annual plant, nat.

order Compositæ, indigenous to America, and easily recognized by its tall stem, 4 or 5 feet in height, passing through the middle of a large double hairy leaf, and surmounted by a broad flat head of light purple flowers. It is much used as a domestic medicine in the form of an infusion, having tonic and diaphoretic properties.

**Bonfire**, a large fire lighted out of doors in celebration of some event; originally a fire in which bones were burned.

**Bonheur** (bo-*neur*), ROSA, a distinguished French artist and painter of animals, born at Bordeaux 22d March, 1822. When only eighteen years old she exhibited two pictures, Goats and Sheep, and Two Rabbits, which gave clear indications of talent. Since that time a long list of pictures, Tillage in Nivernais (1849), the Horse Fair (1853), Haymaking (1865), &c., have made her name famous throughout Europe.

**Bonifaccio** (bō-nē-fāch'ō), a seaport in Corsica, on the strait of same name, which separates Corsica from Sardinia. Wine and oil are exported, and a coral fishery is carried on. Pop. 3594. The Strait of Bonifaccio is 7 miles broad, and contains several small islands.

**Boniface**, the name of nine popes.—**BONIFACE I.**, elected 418. He was the first to assume the title of the First Bishop of Christendom. He died 422.—**BONIFACE II.**, elected 530, died in 532. He acknowledged the supremacy of the secular sovereign in a council held at Rome.—**BONIFACE III.**, chosen 607, died nine months after his election.—**BONIFACE IV.**, elected 608. He converted the Pantheon at Rome into a Christian church.—**BONIFACE V.**, 619 to 625. He endeavoured to diffuse Christianity among the English.—**BONIFACE VI.**, elected 896, died a fortnight after.—**BONIFACE VII.**, elected 947, during the lifetime of Benedict VI., and therefore styled antipope. Expelled from Rome in 984, he returned and deposed and put to death Pope John XIV. He died 985.—**BONIFACE VIII.** (1294–1303), Benedict Cajetan, one of the ablest and most ambitious of the popes. His idea was, like that of Gregory VII., to raise the papal chair to a sort of universal monarchy in temporal as well as spiritual things. In pursuit of this design he was engaged in incessant quarrels with the German emperors and King Philip of France. He was not, however, very successful. The excommunication which he launched against Philip of France met with no respect, and he

was proceeding to lay all France under interdict when he was seized at Anagni by an agent of Philip and a member of the great Colonna family which Boniface had banished from Rome. After three days' captivity the people of Anagni rose and delivered him; but he died a month later, probably from the privations and agitation he had undergone. In 1300 Boniface instituted the jubilees of the church, which, at first centennial, afterwards every twenty-five years, became a great source of revenue to the papal treasury.—**BONIFACE IX.** (1389–1404), elected during the schism in the church while Clement VII. resided at Avignon. He made a shameless traffic of ecclesiastical offices, dispensations, &c., and lavished the treasures thus procured on his relations or on costly edifices—the fortification of the castle of St. Angelo, for instance, and the Capitol. He died in 1404.

**Boniface**, St., the apostle of Germany, whose original name was Winfrid, was born in Devonshire in 680, of a noble Anglo-Saxon family. In his thirtieth year he took orders as a priest, and in 718 he went to Rome and was authorized by Gregory II. to preach the gospel to the pagans of Germany. His labours were carried on in Thuringia, Bavaria, Friesland, Hesse, and Saxony, through all of which he travelled, baptizing thousands and consecrating churches. Latterly he erected bishoprics and organized provincial synods. In 723 he was made a bishop, and in 732 an archbishop and primate of all Germany. Many bishoprics of Germany, as Ratisbon, Erfurt, Paderborn, Würzburg, and others, and also the famous abbey of Fulda, owe their foundation to him. He was slain in West Friesland by some barbarians in 755, and was buried in the abbey of Fulda.

**Bonin'**, or **ARCHBISHOP ISLANDS**, several groups of islands, North Pacific Ocean, belonging to Japan, and lying to the south of it. The largest is Peel Island, which is inhabited by some English, Americans, and Sandwich Islanders, who cultivate maize, vegetables, tobacco, and the sugar-cane. It is frequently visited by vessels engaged in whale-fishing, which obtain here water and fresh provisions.

**Bonito** (bo-nē'tō), a name applied to several fishes of the mackerel family, one of which, the bonito of the tropics, or stripe-bellied tunny (*Thynnus pelāmys*), is well known to voyagers from its persistent pursuit of the flying-fish. It is a beautiful

fish, steel-blue on the back and sides, silvery on the belly, with four brown longitudinal bands on each side. It is good eating, though rather dry. The *Auxis vulgāris* and *Pelāmys sarda* also go under this name.

**Bonn**, an important German town in the Rhenish province of Prussia, beautifully situated on the left bank of the Rhine, with magnificent promenades and prospects in the environs. It has some trade and manufactures, but is chiefly important for its famous university founded in 1777 by Elector Maximilian Frederick of Cologne. Enlarged and amply endowed by the King of Prussia in 1818, it is now one of the chief seats of learning in Europe, with a library of more than 200,000 volumes, an anatomical hall, mineralogical and zoological collections, museum of antiquities, a botanical garden, &c. The teachers in the five faculties are above a hundred, and the students number about 1100. Lange, Niebuhr, Ritschl, Brandis, and other names famous in science or literature are connected with Bonn, and Beethoven was born there. Bonn was long the residence of the Electors of Cologne, and finally passed into the hands of Prussia by the arrangements of the Congress of Vienna in 1815. Pop. 35,989.

**Bonner**, EDMUND, an English prelate of infamous notoriety, was born about 1495, of obscure parentage. He took a doctor's degree at Oxford in 1525, and, attracting the notice of Cardinal Wolsey, received from him several offices in the church. On the death of Wolsey he acquired the favour of Henry VIII., who made him one of his chaplains, and sent him to Rome to advocate his divorce from Queen Catharine. In 1540 he was consecrated Bishop of London, but on the death of Henry (1547), having refused to take the oath of supremacy, he was deprived of his see and thrown into prison. On the accession of Mary he was restored to his bishopric, and he distinguished himself during this reign by a persecution of the Protestants, 200 of whom he was instrumental in bringing to the stake. After Elizabeth succeeded he remained unmolested until his refusal to take the oath of supremacy, on which he was committed to the Marshalsea (1560), where he remained a prisoner until his death in 1569.

**Bon'net**, in fortification, a small defence-work constructed at the salient angles of a field retrenchment or other military construction, designed to prevent the enfilading of the front of the work.

**Bon'net**, a covering for the head, now especially applied to one worn by females. In England the bonnet was superseded by the hat as a head-dress two or three centuries ago, but continued to be distinctive of Scotland to a later period.

**Bonnet-piece**, a Scotch coin, so called from the king's head on it being decorated with a bonnet instead of a crown. It was struck by James V., and is dated 1539. Bonnet-pieces are very rare, and in high estimation amongst antiquaries.

**Bonnet-rouge** (bo-nā-rōzh; Fr. 'red-cap'), the emblem of liberty during the French Revolution, and then worn as a head-dress by all who wished to mark themselves as sufficiently advanced in democratic principles: also called *cap of liberty*.

**Bonneval** (bon-vāl), CLAUDE ALEXANDRE, COUNT, a singular adventurer, born in 1675 of an illustrious French family. In the war of the Spanish Succession he obtained a regiment, and distinguished himself by his valour as well as by his excesses. On his return to France he was obliged to fly in consequence of some expressions against the minister and Madame de Maintenon. Received into the service of Prince Eugene he now fought against his native country, and, after performing many signal services, he was raised in 1716 to the rank of lieutenant field-marshal in the Austrian service, and distinguished himself against the Turks at Peterwardein. But his reckless and impatient spirit brought him into conflict with the superior authorities, and he finally took refuge in Constantinople, where he was well received. He was now converted to Moham-medanism, submitted to circumcision, received the name of *Achmet*, was made a pasha of three tails, and as general of a division of the army achieved some considerable successes against Russians and Austrians. He died in 1747. The memoirs of his life published under his name are not genuine.

**Bonnivard** (bon-ē-vār), FRANÇOIS DE, the 'prisoner of Chillon,' born in 1496. An ardent republican, he took the side of the Genoese against the pretensions of the Dukes of Savoy. In 1530 he fell into the hands of the duke, and was imprisoned till 1536 in the castle of Chillon, when the united forces of the Genevese and the Bernese took Chillon. He died at Geneva 1570.

**Bonny**, a river of W. Africa, one of the mouths of the Niger, where a considerable trade is done.

**Bonpland** (bōn-plān), AIMÉ, a distinguished French botanist, born at Rochelle 1773. While pursuing his studies at Paris he made the acquaintance of Alexander von Humboldt, and agreed to accompany him in his celebrated expedition to the New World. During this expedition he collected upwards of 6000 plants, previously unknown, and on his return to France in 1804 was made director of the gardens at Navarre and Malmaison. On the Restoration he proceeded to South America, and became professor of natural history at Buenos Ayres. Subsequently, while on a scientific expedition up the river Paraná, he was arrested by Dr. Francia, the dictator of Paraguay, as a spy, and detained for eight years. He afterwards settled in Brazil, where he died in 1858.

**Bon'tebok**, the pied antelope (*Alcelaphus pygarga*), an antelope of S. Africa, with white markings on the face, allied to the blesbok.

**Bo'nus**, something given over and above what is required to be given, especially an extra dividend to the shareholders of a joint-stock company, holders of insurance policies, &c., out of accrued profits.

**Bony Pike**, or GAR-FISH (*Lepidostēus*), a remarkable genus of fishes inhabiting North American lakes and rivers, and one of the few living forms that now represent the order of ganoid fishes so largely developed in previous geological epochs. The body is covered with smooth enamelled scales, so hard that it is impossible to pierce them with a spear. The common gar-fish (*L. ossēus*) attains the length of 5 feet, and is easily distinguished by the great length of its jaws.

**Bonzes**, the name given by Europeans to the priests of the religion of Fo or Buddha in Eastern Asia, particularly in China, Burmah, Tonquin, Cochin-China, and Japan. They do not marry, but live together in monasteries. There are also female bonzes, whose position is analogous to that of nuns in the Roman Catholic Church.

**Booby** (*Sula fusca*), a swimming bird nearly allied to the gannet, and so named from the extraordinary stupidity with which, as the older voyagers tell, it would allow itself to be knocked on the head without attempting to fly. The booby lives on fish, which it takes, like the gannet, by darting down upon them when swimming near the surface of the water.

**Boodha**. See *Buddha*.

**Boodroom**, a seaport near the south-west

of Asia Minor, close by the site of ancient Halicarnassus. Pop. 6000.

**Book**, the general name applied to a printed volume. In early times books were made of the bark of trees; hence the Latin *liber* means bark and book, as in English the words *book* and *beech* may be connected. The materials of ancient books were largely derived from the papyrus, a plant which gave its name to paper. The use of parchment, prepared from skins, next followed, until it was supplanted in Europe by paper in the 12th century, though paper was made in Asia long before this. See *Bibliography*, *Bookbinding*, *Book-trade*, &c.

**Book'binding**, the art of making up the sheets of a book into a volume with a substantial case or covering. In the middle ages the work of binding the manuscripts then used was done by the monks, in a heavy and excessively solid style. With the invention of printing, and the consequent multiplication of books, binding became a great mechanical art, in which the Italians of the 15th and 16th centuries took the lead. Later on the French binders enjoyed a well-deserved supremacy for delicate and elegant work, and it was not till almost the opening of the 19th century that English bookbinding began to take the foremost place.

The first operation in bookbinding is to fold the sheets—into two leaves if the book be folio; if quarto, into four leaves; octavo, eight leaves; and so of all others. After the sheets are folded, they are arranged in the proper order, according to the letters or figures, technically called *signatures*, which are printed at the bottom of the first page of each sheet. The collected sheets are pressed in a screw or hydraulic press for several hours, and the book being now firm and solid, shallow channels are sawed across the back in several places, in order to admit the cords to which the sheets are to be sewed and the boards fastened. A sewing bench is used in the operation of attaching the sheets to the cords by threads passing round the latter. The back is then covered with a coating of glue, and when dry rounded with a hammer, and afterwards beaten till it projects a little over the boards that compress it, so that a groove is formed for the edges of the boards to rest in. The boards are then laced to the book by the ends of the cords on which the sheets are sewed. The book is then pressed again for several hours, to make it solid for cutting the edges, which is performed by a machine

called a *plough*. Before the front edge is cut the back is made flat, and after cutting it is again rounded, leaving the face hollow. When the book is cut it may either be gilt, marbled, sprinkled, or coloured on the edges, or left white. In gilding, the edges are made perfectly smooth, then sized with white of egg mixed with water, and covered with the gold-leaf. After having dried, the gold is burnished with an agate burnisher. Marbling is done by dipping the edges slightly into the colouring mixture as it floats on the surface of gum-water. Sprinkling is performed with a brush, which the workman dips in colour and shakes in small drops on the edges. After the head-band has been added the book is ready for the leather cover. The cover, after being dampened with water, and having the rough side smeared with strong paste made of flour, is now pulled on, and doubled over the edges of the boards. The sides and edges are then neatly squared and smoothed, and the book is put for some hours into the press, after which it is ready for its ornaments and letters. The letters or ornaments on books are made with brass tools engraved in relief. A book is called *half-bound* when only the back and corners are leather.

The above description applies chiefly to the binding of books in leather, and in the strongest manner; but an immense number of books are now bound entirely in cloth, a style of binding which, though less strong, is cheaper and more expeditious, and often very handsome. The cloth covers or 'cases' are made up complete — embossed, gilt, and lettered — before being attached to the book, the ornaments being stamped upon them by presses acting on metal dies. The covers are usually attached by thin canvas glued to the backs, as well as by the back-cords, or tapes used instead. A simpler method of binding is commonly practised in the case of engravings, atlases, manuscripts, &c., when the volumes are made up of separate leaves instead of sheets. It consists in smearing the back of the book, while placed in the press, with a solution of caoutchouc, by which means each paper edge receives a little of this tenacious substance, and all are firmly kept in their places. Such books open up quite flat at once.

**Book-keeping** is the art or method of recording mercantile or pecuniary transactions, so that at any time a person may be able to ascertain the details and the extent of his business. It is divided, according

to the general method pursued, into book-keeping by *single* or by *double entry*. Book-keeping by single entry is comparatively little used, except in retail businesses of small extent, where only the simplest record is required. In its simplest form debts due to the trader are entered in the day-book at the time of the transaction to the debit of the party who owes them; and debts incurred by the trader to the credit of the party who gave the goods. From this book the accounts in a summarized form are transferred to the ledger, where one is opened for each different person, one side being for Dr., and the other for Cr. When a balance-sheet of the debts owing and owed is made, this, together with stock and cash in hand, shows the state of the business.

Book-keeping by double entry, a system first adopted in the great trading cities of Italy, gives a fuller and more accurate record of the movement of a business, and is necessary in all extensive mercantile concerns. The chief feature of double entry is its system of checks, by which each transaction is twice entered, to the Dr. side of one account and then to the Cr. side of another. An important feature of the system consists in adopting, in addition to the personal accounts of debtors and creditors contained in the ledger, a series of what are called *book-accounts*, which are systematic records in the form of debtor and creditor of particular classes of transactions. For every debt incurred some consideration is received. This consideration is represented under a particular class or name in the ledger, as the debtor in the transaction in which the party from whom the consideration is received is the creditor. Thus A buys goods to the value of \$500 from B. He enters these in his journal—Stock Acct. Dr. \$500 (for goods purchased) To B, \$500. The first \$500 appears in the Dr. column of the journal, and is posted in the ledger to the debit of Stock Account; the second appears in the Cr. column, and is posted in the ledger to the Cr. of B. In like manner, when the goods are paid, Cash, for which an account is opened in the ledger, is credited with \$500, and B is debited with the same. When the goods are sold (for cash) Stock is credited and Cash is debited. If the amount for which they sell is greater than that for which they were bought, there will be a balance at the debit of Cash, and a balance at the credit of Stock. The one balance represents the cash actually on

hand (from this transaction), the other the cause of its being on hand. If there is a loss on the transaction, the balance will be on the other side of these accounts. Ultimately the balance thus arising at Dr. or Cr. of Stock is transferred to an account called Profit and Loss, which makes the stock account represent the present value of goods on hand, and the profit and loss account, when complete, the result of the business. In this system the risk of omitting any entry, which is a very common occurrence in single book-keeping, is reduced to its smallest, as unless a particular transaction is omitted in every step of its history, the system will inexorably require that its whole history should be given to bring the different accounts into harmony with each other.

In keeping books by double entry, the books composing the set may be divided into two classes, called principal and subordinate books. The subordinate books are those in which the transactions are first recorded, and vary both in number and arrangement with the nature of the business and the manner of recording the facts. The most important of these (all of which are not necessarily to be found in the same set) are Stock Book, Cash Book, Bill Book, Invoice Book, Account Sales Book. The principal books are made up exclusively from the subordinate books and classified documents of the business. In the most perfect system of double entry they consist of two, the Journal and Ledger. The journal contains a periodical abstract of all the transactions contained in the subordinate books, or in documents not entered in books, classified into debits and credits. The ledger contains an abstract of all the entries made in journal classified under the heads of their respective accounts. It is an index to the information contained in the journal, and also a complete abstract of the actual state of all accounts, but gives no further information; while the journal gives the reason of each debit and credit, with a reference to the source where the details of the transaction are to be found.

**Books, CENSORSHIP OF,** the supervision of books by some authority so as to settle what may be published. After the invention of printing the rapid diffusion of opinions by means of books induced the governments in all countries to assume certain powers of supervision and regulation with regard to printed matter. The popes were the first to institute a regular censorship.

By a bull of Leo X. in 1515 the bishops and inquisitors were required to examine all works before they were printed, with a view to prevent the publication of heretical opinions. As this decree could not be carried out in countries which had accepted the reformed religion, they prepared a list of prohibited books (*Index Librorum Prohibitorum*), books, that is, which nobody was allowed to read under penalty of the censure of the church. This index continues to be reprinted and revised down to date, as well as another index commonly called the *Index Expurgatorius*, containing the works which may be read if certain expurgations have been made. In England the censorship was established by act of parliament in 1662, but before that both the well-known Star-chamber and the parliament itself had virtually performed the functions. In 1694 the censorship in England ceased entirely. In France the censorship, like so many other institutions, was annihilated by the revolution. During the republic there was no formal censorship, but the supervision of the directory virtually took its place, and at length in 1810 Napoleon openly restored it under another name (*Direction de l'Imprimerie*). After the restoration it underwent various changes, and was re-established by Napoleon III. with new penalties. In the old German empire the diet of 1530 instituted a severe superintendence of the press, but in the particular German states the censure was very differently applied, and in Protestant states especially it has never been difficult for individual authors to obtain exemption. In 1849 the censorial laws were repealed, but were again gradually introduced, and still exist in a modified form in most of the German states. The censorship was abolished in Denmark in 1770, in Sweden in 1809, in the Netherlands in 1815. In Russia and Austria there is a despotic censorship. See *Press, Liberty of the*.

**Book-trade,** the production and distribution of books commercially. Even in ancient times, before the invention of printing, this trade had attained a high degree of development, at Alexandria and later at Rome, where Horace mentions the brothers Sosii as the chief booksellers of his time. Copies of books were readily multiplied in those times, as we hear of as many as a thousand slaves being employed at one time in writing to dictation. After the fall of Rome down to the 12th century, the trade in

books was almost entirely confined to the monasteries, and consisted chiefly in the copying of manuscripts and the barter or sale of the copies, generally at a very high price. But with the rise of the universities the trade received a new development, and in all university towns booksellers and book-agents became numerous. The invention of printing had a powerful effect on the trade of bookselling, as was first manifested in the commercial towns and free cities of the German empire. The printers were originally at the same time publishers and booksellers, and they were in the habit of disposing of their books at the chief market-towns and places frequented by pilgrims. It was only in the 16th century that these two branches of trade began generally to be carried on independently.

The two chief departments of the book-trade now are publishing and bookselling by retail in all its branches, printing being regarded as a separate business. For the most part these two departments of the trade are carried on separately, but it is not uncommon for them to be united. The publisher of a book is the one who brings it before the public in a printed form, often purchasing the copyright, with the condition of publishing the work at his own risk; or the risk (profit or loss) may be shared between the author and publisher. Very frequently books are printed at the cost of the author or some learned society, and published on commission. In order to secure as large a sale as possible, the publisher brings himself into connection with the retail booksellers, who are the direct means of distributing the book to the public. Second-hand booksellers belong to a special department of the retail book-trade. Many of the books they deal in are long ago out of print. In Britain the chief seat of the book-trade is London, Edinburgh coming next (after a long interval); but publishing is also carried on to a considerable extent in Dublin, Manchester, Glasgow, and some other places. In France the centre of the book-trade is Paris, where almost all the books appear which make any pretensions to occupy an important place in literature. The book-trade of North America, the chief seats of which are New York, Philadelphia, and Boston, is now very large. The manner in which it is conducted is almost the same as in Britain. Canada and Australia are also developing a considerable business of this kind. The great centre of the Ger-

man book-trade is at Leipzig, and the fair held in the latter city at Easter is the occasion on which all the accounts made in the book-trade during the past year are settled. The common practice is for the booksellers to receive supplies of new books from the publishers on commission, with liberty to send back to the publisher all the copies that are not sold before the time of settlement at the Easter Fair (*Ostermesse*), or to carry over a part of them to next year's account if the sale has so far been unsuccessful. All business between the publishers and retail booksellers is carried on indirectly by means of commission-agents, especially in Leipzig, but also in Berlin, Vienna, Frankfort, and other towns. Every bookseller out of Leipzig has his agent there, who conducts all his business, and is in constant communication with the other booksellers. A large number of the publishers deposit with their agents at Leipzig a stock of the works which they have published, and commission them to carry out all orders on their account. The retail bookseller sends all his orders to his agent, who communicates them to the Leipzig publishers and the agents of the other publishers. In Italy there is no central point either for the production of books or for the conduct of the trade by means of agents. Florence, Milan, and Turin hold nearly the same position.

In publishing new books, besides the expense of copyright, paper, presswork, &c., the publisher has to consider the number of presentation copies required for reviews, the percentage off the price allowed to the retail bookseller, in many cases also to the commission-agent, and the expenses of advertising and making the work known to the public. This last is a very important department of a publishing office, and it is nothing uncommon for a publisher to spend \$10,000 or \$15,000 on advertising an important work. The total number of works (including new editions) annually published in Britain is usually between 6000 and 7000; the annual number of German publications is stated at about 17,000; France is said to produce about the same number. These figures do not afford a fair comparison, however, in the absence of any agreement as to what constitutes a book.

**Boo-lac'**. See *Boulak*.

**Boole**, GEORGE, English mathematician and logician, born in 1815, died in 1864. A native of Lincoln and educated there, he

opened a school in his twentieth year, and by private study gained such proficiency in mathematics that in 1849 he was appointed to the mathematical chair in Queen's College, Cork, where the rest of his life was spent. In 1857 the universities of Dublin and Oxford conferred on him the degrees of LL.D. and D.C.L. respectively. In mathematics he wrote on Differential Equations; General Method in Analysis; The Comparison of Transcendents, &c. In logic he wrote An Investigation of the Laws of Thought, and The Mathematical Analysis of Logic, a profound and original work, in which a symbolic language and notation were employed in regard to logical processes.

**Boolundshuhur.** See *Bulandshahr*.

**Boom**, a long pole or spar run out from various parts of a ship or other vessel for the purpose of extending the bottom of particular sails. Also a strong beam, or an iron chain or cable, fastened to spars extended across a river or the mouth of a harbour, to prevent an enemy's ships from passing.

**Boom** (bōm), a town in Belgium, about 10 miles south of Antwerp. Pop. 13,239.

**Boomerang**, a missile instrument used by the Australian aborigines, and by some peoples of India, made of hard wood, about the size of a common reaping-hook, and of



Boomerangs.

a peculiar curved shape, sometimes resembling a rude and very open V. The boomerang, when thrown as if to hit some object in advance, instead of going directly forward, slowly ascends in the air, whirling round and round to a considerable height, and returns to the position of the thrower. If it hits an object of course it falls. The Australians are very dexterous with this weapon, and can make it go in almost any direction, sometimes making it rebound before striking.

**Boondee'**, or **BUNDI**, a principality, Hindustan, in Rajputana, under British protection; area, 2300 square miles. Although small, Boondee is important as the medium of communication between the N. and S.

Pop. 254,701. Boondee, the capital, is picturesquely situated, and its antiquity, numerous temples, and magnificent fountains give it a very interesting appearance, Pop. 20,744.

**Boone, DANIEL**, an American pioneer of civilization, born 1735, died 1820. In 1769 with five companions he went to explore the little known region of Kentucky, and was taken prisoner by the Indians. In 1775 he built a fort on the Kentucky river, where Boonesborough now is, and settled there. In 1778 he was taken prisoner by the Indians, and was retained and adopted into the family of a Shawanese chief, but at length he effected his escape. In the end of the century he removed from Kentucky into Missouri. From him a number of places in the United States take the name.

**Boone**, Boone county, Iowa; noted for coal and lumber. Pop. in 1890, 6518.

**Boorhanpoor'**. See *Burhānpur*.

**Boo'ro**, one of the Molucca Islands in the Indian Archipelago, w. of Ceram and Amboyna, belonging to the Dutch. It is oval in shape, 92 miles long and 70 broad. Though mountainous and thickly covered with wood, it is productive, yielding rice, dye-woods, &c. Pop. 8000.

**Booroojird**, a town, Persia, province of Irak-ajemi, in a fertile and well-cultivated valley. Pop. 20,000.

**Boossa.** See *Boussa*.

**Boot**, an article of dress, generally of leather, covering the foot and extending to a greater or less distance up the leg. Hence the name was given to an instrument of torture made of iron, or a combination of iron and wood, fastened on to the leg, between which and the boot wedges were introduced and driven in by repeated blows of a mallet, with such violence as to crush both muscles and bones. The special object of this form of torture was to extort a confession of guilt from an accused person.

**Bootan'**. See *Bhutan*.

**Bootes** (bo-ō'tēz; that is, ox-driver), the Greek name of a northern constellation, called also by the Greeks *Arctophylax*. It contains Arcturus, a star of the first magnitude.

**Booth, BARTON**, an English actor of celebrity in the reigns of Queen Anne and George I. He was born in 1681, and placed under Dr. Busby, at Westminster School, but he eloped from school at the age of seventeen, and joined a company of strolling players. After performing in the Irish



capital with great applause, he returned in 1701 to London, where, having joined the Drury Lane Company, his reputation reached its height with the performance of Cato in Addison's famous tragedy. He died in May, 1733.

**Booth**, EDWIN THOMAS, an American actor, son of the distinguished English actor, Junius Brutus Booth (1796-1852; spent most of his life in the U. States). He was born in 1833 in Bel Air, Md., and made his first appearance at Boston in 1849. He was eminent for his personation of Shaksperian characters, Othello, Richard III., Iago, Shylock, &c., and was regarded as the leading American tragedian. In 1882 he made a professional tour in Europe, and was favourably received. In 1887, in company with Lawrence Barrett, he played in the United States to immense audiences. In 1888 he founded the Players' Club, to which he gave a sumptuous club-house. His last appearance in public was made at the Players', Jan. 1, 1892. He died June 7, 1893. His brother JOHN WILKES (born 1839), also an actor, was the murderer of President Lincoln, April 14, 1865. He was shot by those who sought to bring him to justice.

**Boo'thia Felix**, a peninsula of British North America, stretching northwards from the Arctic circle, discovered by Captain Ross in 1830. In the west coast of this country Ross was able to localize the north magnetic pole.

**Boo'tle**, a municipal borough of England, adjoining Liverpool. Pop. 49,217.

**Bopp**, FRANZ, a distinguished German Sanskrit scholar and philologist, born at Mainz, in 1791, died at Berlin in 1867. In 1812 he went to Paris for the study of Sanskrit and oriental literature, and remained there five years. After living for some time in London and Göttingen, he settled in Berlin, where he eventually became ordinary professor of oriental literature. He contributed much to the study of Sanskrit in Europe, and he may be said to have been the first who raised philology to the rank of a science. His most important work in the field was his Comparative Grammar of Sanskrit, Zend, Greek, Latin, Gothic, old Slavonic, and German, of which an English translation has been published.

**Boppard** (bop'ärt), an ancient walled town of Rhenish Prussia, district Coblenz, on the left bank of the Rhine, formerly an imperial city. Pop. 5594.

**Bo'ra**, KATHARINA VON, wife of Luther, was born in 1499. She took the veil early; but feeling unhappy in her situation, applied, with eight other nuns, to Luther. The nuns were released from their convent, and in 1525 Luther married her, having himself by this time laid aside the cowl. After Luther's death she kept boarders for her support. She died at Torgau in 1552.

**Boracic Acid**, BORIC ACID, a compound of the element boron, with hydrogen and oxygen ( $H_3BO_3$ ). Boracic acid is found as a saline incrustation in some volcanic regions, is an ingredient in many minerals, and is contained in the steam which, along with sulphureous exhalations, issues from fissures in the soil in Tuscany. The steam from the *fumaroles* here is now an important source of the acid, a system of condensation and evaporation being employed. The acid forms white, shining, scaly crystals, which on heating melt into a transparent mass, when cooled resembling glass. It dissolves in water, and has a slight acid taste; it colours blue litmus purple, and the yellow colouring matter turmeric brown. The chief use of the acid is as a source of borax, the baborate of sodium. See *Borax*.

**Bo'rage** (*Borāgo*), a genus of plants belonging to the nat. order Boraginaceæ, having rough hairy foliage and blue, paniced, drooping flowers, and characterized by mucilaginous, and emollient properties. *Borāgo officinālis*, a common plant, gives a coolness to beverages in which its leaves are steeped, and was ranked formerly as one of the cordial flowers.

**Boragina'ceæ**, the Borage family, a nat. order of regular-flowered monopetalous dicotyledons, with alternate rough leaves, containing a large number of herbs or shrubs chiefly found in the northern temperate regions, among them being borage, alkanet, comfrey, and forget-me-not.

**Boras'sus**. See *Palmyra Palm*.

**Borax**, baborate of sodium ( $N_2B_4O_7$ ). Native borax has long been obtained under the name of *tincal*, from India, the main source being not India but a series of lakes in Thibet. As imported it is in small pieces of a dirty yellowish colour, and is covered with a fatty or soapy matter. Tincal, which contains various impurities, was formerly the only source of borax; but besides Tuscany other sources of boracic acid, more particularly in North and South America, and the salt mines at Stassfurt, &c., in Germany, have been rendered avail-

## BORDA — BORDEAUX.

able. North America yields large quantities, there being rich deposits of borax and boracic minerals on the Pacific slope. Pure borax forms large transparent six-sided prisms, which dissolve readily in water, effloresce in dry air, and when heated melt in their water of crystallization, swell up, and finally fuse to a transparent glass. Borax has a variety of uses. In medicine it is employed in ulcerations and skin dis-

eases. It has valuable antiseptic and disinfecting properties, and is now much used for the preservation of meat, fish, and milk. It is also employed in soldering metals, and in making fine glaze for porcelain, as it renders the materials more fusible. It is used in enamelling, and in making beads, glass, and cement. See *Boracic Acid*.

**Bor'da**, JEAN CHARLES, a French mathematician and physicist, born in 1733,



Bordeaux—Quay of Louis XVIII.

died 1799. He served in the army and navy, and distinguished himself by the introduction of new methods and instruments connected with navigation, geodesy, astronomy, &c., being in particular the inventor of the reflecting circle. He was one of the men of science who framed the new system of weights and measures adopted in France.

**Bordeaux** (bor-dō'), one of the most important cities and ports of France, capital of the dep. of Gironde, on the Garonne, about 70 miles from the sea. It is built in a crescent form round a bend of the river, which is here lined with fine quays and crossed by a magnificent stone bridge, and consists of an old and a new town. The former is mostly composed of irregular squares and narrow crooked streets; while the latter is laid out with great regularity, and on a scale of magnificence hardly sur-

passed by any provincial town in Europe. In the old town are the Cathedral of Saint-André, St. Michael's Church, with its superb front of florid Gothic, the Hotel de Ville, and the Palais de Justice. There are extensive and finely-planted promenades. Its position gives it admirable facilities for trade, and enables it to rank next after Marseilles and Havre in respect of the tonnage employed. Large vessels sail up to the town, and there is ready communication by railway or river with the Mediterranean, Spain, and the manufacturing centres of France. The chief exports are wine and brandy; sugar and other colonial produce and wood are the chief imports. Ship-building is the chief industry, and there are sugar-refineries, woollen and cotton mills, potteries, soap-works, distilleries, &c. Bordeaux is the *Burdigala* of the Romans. By the

## BORDELAIS WINES — BORGIA.

marriage of Eleanor, daughter of the last Duke of Aquitaine to Henry II. of England, Bordeaux was transferred to the English crown. Under Charles VII. in 1451, it was restored again to France. Montaigne and Montesquieu were born in the neighbourhood; the latter is buried in the church of St. Bernard. Pop. 1891, 252,415.

**Bordelais Wines**, the wines of Bordeaux and district, the name of *vin de Bordeaux* being generally given to the wines made in the eleven departments of the South-west of France, Gironde, Landes, Lot, Tarn et Garonne, &c., though it is in the Gironde alone that the famous growths are found. The soil of Médoc (a sandy and calcareous loam) produces such famous wines as Château-Margaux, Château-Lafitte, and Château-Latour. The wines of this country are the best which France produces. Their characteristics are fine bouquet, velvety softness on the palate, and the faculty of acting beneficially on the stomach without mounting too readily to the head. Besides the red wines of the Bordelais, known under the general name of *claret*, there are also white wines, of which the finest growths are Sauterne, Preignac, Barsac, &c.

**Bor'dentown**, a manufacturing town in New Jersey, U.S., on the Delaware, 26 miles N.E. of Philadelphia. Pop. 4232.

**Border** (or **BORDERS**), **THE**, the territory adjacent to the frontier line between England and Scotland, the scene of frequent fight and foray among neighbouring clans and families from the 11th till the end of the 17th century. The dividing line varied at different times, shifting according to the surging of the tide of war or diplomacy. At present the line consists partly of natural and partly of imaginary outlines from near the mouth of the Tweed to the Solway.

**Bordighera** (bor-dē-gā'ra), town of N.W. Italy on the Mediterranean coast, district of San Remo, favourite winter residence for invalids. Pop. 3000.

**Bordone** (bor-dō'nā), **PARIS**, Italian painter of the Venetian school, born at Treviso in 1500, died at Venice 1570. He was a pupil of Titian, and was invited to France by Francis I. whose portrait he painted, as also those of the Duke of Guise, the Cardinal of Lorraine, and others. His works are not rare in the public and private collections of Europe, his most famous picture being the Old Gondolier Presenting a Ring to the Doge, at Venice.

**Bore**, or **EAGRE**, a sudden influx of the

tide into the estuary of a river from the sea, the inflowing water rising to a considerable height and advancing like a wall against the current. The most celebrated bores in the Old World are those of the Ganges, Indus, and Brahmaputra. The last is said to rise to a height of 12 feet. In some rivers in Brazil it rises to the height of 12 to 16 feet. In Britain the bore is observed more especially in the Severn, Trent, Wye, and Solway.

**Bo'reas**, the name of the north wind as personified by the Greeks and Romans.

**Borecole** (bōr'kōl), a variety of *Brassica oleracea*, a cabbage with the leaves curled or wrinkled, and having no disposition to form into a hard head.

**Borer**, a name given to the larvæ of certain insects which bore holes in trees and thus injure them.

**Borgerhout** (bor'ger-hout), a Belgian town, forming a suburb of Antwerp, with bleaching and dyeing-works, and woollen manufactories, &c. Pop. 25,306.

**Borghese** (bor-gā'ze), a Roman family, originally of Sienna, where it held the highest offices from the middle of the 15th century. Pope Paul V., who belonged to this family, and ascended the papal chair in 1605, loaded his relations with honours and riches. He bestowed, among other gifts, the principality of Sulmone on Marco Antonio Borghese, the son of his brother Giovanni Battista, from whom is descended the present Borghese family.—**BORGHESE**, **CAMILLO PRINCE**, was born in 1775, died in 1832. When the French invaded Italy he entered their service, and in 1803 he married Marie Pauline, the sister of Napoleon (born at Ajaccio 1780, died at Florence 1825). In 1806 he was created Duke of Guastalla, and was appointed governor-general of the provinces beyond the Alps. He fixed his court at Turin, and became very popular among the Piedmontese. After the abdication of Napoleon he broke up all connection with the Bonaparte family, and separated from his wife. The *Borghese Palace* at Rome was begun in 1590, and completed by Paul V. It contains one of the richest collections of art in the city. The *Villa Borghese*, a celebrated country-house just outside the Porta del Popolo, Rome, belonging to the Borghese family, also contains a valuable art collection, and the surrounding grounds are very beautiful.

**Borgia**, **CESARE** (che'zā-re bor'jā), the natural son of Pope Alexander VI., and of

a Roman lady named *Vanozza*, born in 1478. He was raised to the rank of cardinal in 1492, but afterwards divested himself of the office, and was made Duc de Valentinois by Louis XII. In 1499 he married a daughter of King John of Navarre, and accompanied Louis XII. to Italy. He then, at the head of a body of mercenaries, carried on a series of petty wars, made himself master of the Romagna, attempted Bologna and Florence, and had seized Urbino when Alexander VI. died, 1503. He was now attacked by a severe disease, at a moment when his whole activity and presence of mind were needed. He found means, indeed, to get the treasures of his father into his possession, and assembled his troops in Rome; but enemies rose against him on all sides, one of the most bitter of whom was the new pope, Julius II. Borgia was arrested and carried to Spain. He at length made his escape to his brother-in-law the King of Navarre, and was killed before the castle of Viana, March 12, 1507. He was charged with the murder of his elder brother, of the husband of his sister Lucretia, and the stiletto or secret poisoning was freely used against those who stood in his way. With all his crimes he was a patron of art and literature.

**Borgia**, LUCRETIA, daughter of Pope Alexander VI., and sister of Cesare Borgia. In 1493 she was married to Giovanni Sforza, lord of Pesaro, but after she had lived with him for four years, Alexander dissolved the marriage, and gave her to Alphonso, nephew of Alphonso II. of Naples. Two years after this new husband was assassinated by the hired ruffians of Cesare Borgia. Her third husband was Alphonso d'Este, son of the duke of Ferrara. She was accused by contemporaries of incest, poisoning, and almost every species of enormous crime; but several modern writers defend her, maintaining that the charges which have been made against her are false or much exaggerated. She was a patroness of art and literature. Born 1480, died 1523.

**Borgo**, Ital. for 'town' or 'castle,' occurs as part of the names of many places in Italy. One of the most important is *Borgo San Donnino*, a cathedral city of Parma, with a pop. of 5000.

**Bor'gu**, a district of Africa, in the Western Sudan, lying about lat. 10° N., and stretching from the meridian of Greenwich east to the Niger. Kiama and Wawa are chief towns.

**Boring**, the process of perforating wood, iron, rocks, or other hard substances by means of instruments adapted for the purpose. For boring wood the tools used are *awls*, *gimlets*, *augers*, and *bits* of various kinds, the latter being applied by means of a crank-shaped instrument called a *brace*, or else by a lathe, transverse-handle, or drilling-machine. Boring in metal is done by *drills* or *boring-bars* revolved by boring-machines. Boring in the earth or rock for mining, geologic, or engineering purposes is effected by means of augers, drills, or jumpers, sometimes wrought by hand, but now usually by machinery driven by steam or frequently by compressed air. In ordinary mining practice a bore-hole is usually commenced by digging a small pit about 6 feet deep, over which is set up a shear-legs with pulley, &c. The boring rods are from 10 to 20 feet in length, capable of being jointed together by box and screw, and having a chisel inserted at the lower end. A lever is employed to raise the bore-rods, to which a slight twisting motion is given at each stroke, when the rock at the bottom of the hole is broken by the repeated percussion of the cutting-tool. Various methods are employed to clear out the triturated rock. The work is much quickened by the substitution of steam-power, water-power, or even horse-power for manual labour. Of the many forms of boring-machines now in use may be mentioned the diamond boring-machine, invented by Leschot, a Swiss engineer. In this the cutting-tool is of a tubular form, and receives a uniform rotatory motion, the result being the production of a cylindrical core from the rock of the same size as the inner periphery of the tube. The boring-bit is a steel thimble, about 4 inches in length, having two rows of Brazilian black diamonds firmly embedded therein, the edges projecting slightly. The diamond teeth are the only parts which come in contact with the rock, and their hardness is such that an enormous length can be bored with but little appreciable wear.

**Borissoff'**, a Russian town, gov. Minsk. Not far from it took place the disastrous passage of the Berezina by the French in 1812. Pop. 16,537.

**Borissoglebsk**, town of Russia, gov. Tambov; active trade. Pop. 13,007.

**Bor'kum**, a flat sandy island in the North Sea, near the coast of Hanover, off the estuary of the Ems, belonging to Prussia, a favourite resort for sea-bathing. Pop. 600.

BORLASE — BORNEO.

**Bor'lase**, WILLIAM, English writer, born in Cornwall, 1695; died 1772; studied at Oxford, entered into orders, and became successively rector of Ludgvan and vicar of St. Just. In 1754 he published *Antiquities of Cornwall*, and in 1758 *Natural History of Cornwall*.

**Bor'mio**, a small town of N. Italy, prov. Sondrio, with celebrated warm mineral springs. Pop. 1750.

**Born**, BERTRAND DE, French troubadour and warrior, born about the middle of the 12th century in the castle of Born, Périgord; died about 1209. He dispossessed his brother of his estate, whose part was taken by Richard Cœur de Lion in revenge for De Born's satirical lays. Dante places him in the Inferno on account of his verses intensifying the quarrel between Henry II. and his sons.

**Borna**, an old town of Germany, in Saxony, 15 miles S.E. of Leipzig, with some manufactures. Pop. 7350.

**Bor'neo** (corrupted from *Bruni* or *Brunci*, the name of a state on its north-west coast), one of the islands of the Malay Archipelago, and the third largest in the world. It is nearly bisected by the equator, and extends from about 7° N. to 4° S. lat., and from 109° to 119° E. lon.; greatest length 780, greatest breadth, 690 miles; area 283,358 sq. miles. It is not yet well known, though our knowledge of it has been greatly increased in recent years. There are several chains of mountains ramifying through the interior, the culminating summit (13,698 ft.) being Kini-Balu, near the northern extremity. The rivers are very numerous, and several of them are navigable for a considerable distance by large vessels. There are a few small lakes. Borneo contains immense forests of teak and other trees, besides producing various dye-woods, camphor, rattans and other canes, gutta-percha and india-rubber, honey and wax, &c. Its fauna comprises the elephant, rhinoceros, tapir, leopard, buffalo, deer, monkeys (including the orang-outang), and a great variety of birds. The mineral productions consist of gold, antimony, iron, tin, quicksilver, zinc, and coal, besides diamonds. It is only portions of the land on the coast which are well cultivated. Among cultivated products are sago, gambier, pepper, rice, tobacco, &c. Edible birds'-nests and trepang are important articles of trade. The climate is not considered unhealthy. The population is estimated at about 1,700,000, comprising

Dyaks (the majority of the inhabitants), Malays, Chinese, and Bugis. The south-western, southern, and eastern portions of the island are possessed by the Dutch, under whom are a number of semi-independent princes. On the N.W. coast is the Malay kingdom of Borneo or Bruni. Its chief town is Bruni, on the river of the same name, a place of considerable trade, and the resi-



Dyaks of Borneo.

dence of the sultan. Since 1841 there has been a state under English rule (though not under the British crown) on the W. coast of the island, namely, Sarawak (which see), founded by Sir James Brooke, while Labuan, an island off the N.W. coast, is a British colony. Recently an English commercial company, with a charter from the British government, has acquired sovereign rights over the northern portion of the island, extending northwards from about lat. 5° 6' N. on the west, and lat. 4° 5' on the east, and including some adjacent islands. British North Borneo has an area of about 31,000 sq. miles (slightly greater than Scotland), several splendid harbours, a fertile soil, and a good climate. At present the population is sparse, and a large part of the territory consists of virgin forests. The soil is be-

lieved to be well adapted for coffee, sago, tapioca, sugar, tobacco, cotton, &c. Probably there are valuable mineral deposits also, gold having been already found. The chief settlement is Sandakan, the capital, on Sandakan Bay. The government is similar to that of British colonies. The revenue is from customs and excise dues, licences, &c. Birds'-nests, rattans, gutta-percha, timber, &c., are exported, the trade being chiefly with Singapore and Hong Kong. Pop. estimated at 150,000.

**Born'holm**, a Danish island in the Baltic Sea, 24 miles long and 16 broad; pop. 35,364. It is rather rocky, and better suited for pasture than tillage. The people are chiefly engaged in agriculture and fishing; pottery ware and clocks are made. Rønne is the chief town.

**Bor'nu**, a negro kingdom of the Central Sudan, on the w. side of Lake Chad, with an area of about 79,000 sq. miles, and a pop. estimated at 5,000,000. It is a pleasant and fruitful land, intersected by streams that enter Lake Chad, and presents a remarkable example of negro civilization, having a well-organized administration, a court and government, with all its dignities and offices. The people practise agriculture and also various arts and manufactures. They are Mohammedans. The *Mai*, or sultan, has an army of 30,000 men, many armed with fire-arms. Kuka, the capital (pop. 60,000), near the western shore of Lake Chad, is one of the greatest markets in Central Africa, a large trade being done in horses, the breed of which is famed throughout the Sudan. Another large town, on the shore of the lake, is Ngornu. The whole policy of the state is based on slavery.

**Boro Bu'dor**, the ruin of a splendid Buddhist temple in Java, situated near the junction of the rivers Ello and Progo. It is a pyramid, each side measuring 600 feet at the base; and is supposed to belong to the 7th century of our era.

**Borodino'**, BATTLE OF (called also *battle of the Moskwa*), a sanguinary battle fought near a village of this name on the river Moskwa, 7th September, 1812, between the French under Napoleon and the Russians under Kutusoff. Each party claimed the victory. At the end of the day the Russians retreated in good order, no pursuit taking place. The French force amounted to about 150,000 men; the Russian was somewhat less; 50,000 dead and dying covered the field.

**Boro-glyceride**, a compound of boracic acid with glycerine, represented by the formula  $C_3H_5BO_2$ . It is a powerful anti-septic, and being perfectly harmless is as useful in the preservation of food as in surgery, &c.

**Boron** (symbol B, atomic weight 11), the element from which all boracic compounds are derived, is a dark brown or green amorphous powder, which stains the skin, has no taste or odour, and is only slightly soluble in water. It also crystallizes into darkish brilliant crystals nearly as hard as diamond, which, in the form of dust, are used for polishing. It is one of the few elements which combine direct with nitrogen.

**Borough** (bu'rō), originally a fortified town. In England, a corporate town or township; a town with a properly organized municipal government. If it sends a representative or representatives to parliament it is a *parliamentary borough*, if not it is only a *municipal borough*. The qualifications for voters in both classes of boroughs are the same. In all boroughs a mayor is chosen annually, and a certain number of aldermen and councillors periodically, the burgesses or voters electing the councillors, and the councillors electing the mayor and aldermen. Mayor, aldermen, and councillors form the council. In the United States an incorporated town or village.

**Borough-English**, in law, a mode of descent in some ancient boroughs and manors, in which the owner's youngest son, or his youngest brother (if he has no issue), is the heir. Evidently a custom of Saxon origin, and so named to distinguish it from the Norman customs.

**Borovitchi** (-vich'ē), a Russian town, gov. of Novgorod, on the great canal and river water-way which connects the Volga with Lake Ladoga. Pop. 9918.

**Borovsk'**, a Russian town, gov. Kaluga, with a good trade. Pop. 9659.

**Borrrome'an Islands**, four small islands in Lago Maggiore, N. Italy, taking their name from the family of Borromeo. Vitelliano Borromeo in 1671 caused garden soil to be spread over them, and converted them from barren rocks into gardens. Isola Bella, the most celebrated of the group, contains a handsome palace, with gardens laid out upon terraces rising above each other.

**Borrrome'o**, CARLO, COUNT, a celebrated Roman Catholic saint and cardinal, born 1538, at Arona, on Lago Maggiore, died at

Milan 1584. In 1560 he was successively appointed by his uncle Pius IV. apostolical prothonotary, refendary, cardinal, and Archbishop of Milan. The re-opening and the results of the Council of Trent, so advantageous to the papal authority, were chiefly effected by the great influence of Borromeo, which was felt during the whole sitting of the council. He improved the discipline of the clergy, founded schools, libraries, hospitals, and was indefatigable in doing good. Immediately after his death miracles were said to be wrought at his tomb, and his canonization took place in 1610.—His nephew, COUNT FEDERIGO BORROMEO, also cardinal and Archbishop of Milan, equally distinguished for the sanctity of his life and the benevolence of his character, was born at Milan in 1564; and died in 1631. He is celebrated as the founder of the Ambrosian Library (which see).

**Bor'row**, GEORGE, English writer, born 1803, died 1881. He had a passion for foreign tongues, stirring scenes, and feats of bodily prowess. He associated much with the gypsies, and acquired an exact knowledge of their language, manners, and customs. As agent of the British and Foreign Bible Society he travelled France, Germany, Russia, and the East; spent five years in Spain, and published *The Gypsies in Spain* (1841), and *The Bible in Spain* (1842), the best known of his works. Other works are *Lavengro*, largely autobiographical (1850), *The Romany Rye* (1857), *Wild Wales* (1862), and *Dictionary of the Gypsy Language* (1874).

**Bor'rowdale**, a beautiful valley in the lake district of England, in Cumberland, at the head of the Derwent.

**Borrowing Days**, the last three days of March; the popular notion being, in Scotland and some parts of England, that they were borrowed by March from April. The fiction is of great antiquity, and probably arose in the observation of a frequent wintry relapse about the end of March.

**Borrowstounness** (popularly Bo'ness'), a town in Linlithgowshire, Scotland, with good docks and a large trade in coal, iron, timber, &c. The wall of Antonius ran through the parish of Borrowstounness, and traces of it, called Graham's Dyke, are still visible. Pop. 4449.

**Borsad**, a town of India, Bombay Presidency, about midway between Baroda and Amedabad, and distant from each about 40 miles. Pop. 12,228.

**Borsip'pa**, a very ancient city of Babylonia, the site of which is marked by the ruins Birs Nimrud.

**Bory de Saint Vincent** (bo-rē-dè-saṅ-vaṅ-saṅ), JEAN BAPTISTE GEORGE MARIE, French naturalist, born 1780; died 1846. About 1800–2 he visited the Canaries, Mauritius, and other African islands. He afterwards served for a time in the army, and conducted scientific expeditions to Greece and to Algiers. Chief works, *Annales des Sciences Physiques* (8 vols.), *Voyage dans les quatre principales Iles des Mers d'Afrique*; *Expedition Scientifique de Morée*; *L'Homme*, *Essai zoologique sur le Genre Humain*.

**Boryslaw** (bor'i-slav), a town of Austria, in Galicia. Ozokerit and petroleum are here obtained. Pop. 9318.

**Borysthenes** (bo-ris'the-nēz), the ancient name of the Dnieper.

**Bosa**, a seaport, west coast of Sardinia, in an unhealthy district, with a cathedral and a theological seminary. Pop. 6500.

**Boscan-Almogaver'**, JUAN, a Spanish poet, born towards the close of the 15th century; died about 1540. He was the creator of the Spanish sonnet, and, in general, distinguished himself by introducing Italian forms into Spanish poetry.

**Boscaw'en**, HON. EDWARD, British admiral, son of the first Viscount Falmouth, was born in 1711, died 1761. He distinguished himself at Porto Bello and Cartagena, and in 1747 took part, under Anson, in the battle of Cape Finisterre. His chief exploit was a great victory in 1759 over the Toulon fleet, near the entrance of the Straits of Gibraltar.

**Bosch-bok** (bosh'bok), the bush-buck, a name given to several South African species of antelope. See *Bush-buck*.

**Bosch-vark** (bosh'vark), the bush-hog or bush-pig of South Africa (*Choiropotamus africanus*), one of the swine family, about 5 feet long, and with very large and strong tusks. The Kaffirs esteem its flesh as a luxury, and its tusks, arranged on a piece of string and tied round the neck, are considered great ornaments.

**Bos'cobel**, locality in Shropshire, remarkable historically as the hiding-place of Charles II. for some days after the battle of Worcester, Sept. 3, 1651. At one time he was compelled to conceal himself among the branches of an oak in Boscobel Wood, where it is related that he could actually see the men who were in pursuit of him and

hear their voices. The 'royal oak,' which now stands at Boscobel, is said to have grown from an acorn of this very tree.

**Boscovich** (bos'ko-vich), ROGER JOSEPH, astronomer and geometrician, born at Ragusa 1711, died at Milan 1787. He was educated among the Jesuits, and entered into their order. He was employed by Pope Benedict XIV. in various undertakings, and in 1750-53 measured a degree of the meridian in the Ecclesiastical States. He afterwards became mathematical professor in the University of Pavia, whence, in 1770, he removed to Milan, and there erected the celebrated observatory at the College of Brera.

**Bo'sio**, FRANÇOIS JOSEPH, BARON, sculptor, born at Monaco 1769, died at Paris 1845. He was much employed by Napoleon and by the successive Bourbon and Orleans dynasties. His works are well known in France and Italy.

**Bosna-Serai**, or SERAJEVO (-se-rī', se-r-ā yā'vō), the capital of Bosnia, situated on the Migliazza, 570 miles W.N.W. of Constantinople. It contains a *serai* or palace, built by Mohammed II., to which the city owes its name. It was formerly surrounded with walls, but its only defence now is a citadel, built on a rocky height at a short distance east from the town. Bosna-Serai is the chief mart in the province, the centre of the commercial relations between Turkey, Dalmatia, Croatia, and South Germany, and has, in consequence, a considerable trade, with various manufactures. Pop. estimated at 46,000.

**Bos'nia**, a Turkish province in the north-west of the Balkan Peninsula, west of Servia, by the Treaty of Berlin (1878) to be administered for an undefined future period by the Austrian government; area (including Herzegovina and Novi-bazar), 23,570 square miles (of which Bosnia Proper occupies 16,000), with (1885) 1,336,091 inhabitants, mostly of Slavonian origin, and speaking the Serbian language. They are partly Mohammedans, partly Roman and Greek Catholics. The country is level towards the north, in the south mountainous. Its chief rivers are the Save, the Verbas, the Bosna, Rama, and Drina. About half the area is covered with forests. Tillage is carried on in the valleys and low grounds; maize, wheat, barley, rye, buckwheat, hemp, tobacco, &c., being grown. Fruits are produced in abundance. Sheep, goats, and swine are numerous. The minerals include coal, which is worked in several places,

manganese, antimony, iron, &c. Among the manufactures are iron goods, arms, leather, linens, and woollens. Bosnia had been subject to Turkey from the beginning of the 15th century till 1875, when an insurrection of the inhabitants led indirectly to the Russo-Turkish war of 1877-78 and the subsequent dismemberment of the Turkish Empire.

**Bos'porus**, or BOSPHORUS, the strait, 19 miles long, joining the Black Sea with the Sea of Marmora, called also the Strait of Constantinople. It is defended by a series of strong forts; and by agreement of the European powers no ship of war belonging to any nation shall pass the Bosphorus without the permission of Turkey. Over this channel (about 3000 feet wide) Darius constructed a bridge of boats on his Scythian expedition. (See *Constantinople*.) The *Cimmerian Bosphorus* was the name given by the ancients to the strait that leads from the Black Sea into the Sea of Azov. There was also anciently a kingdom of the name

of Bosphorus, so called from this strait, on both sides of which it was situated.

**Boss**, in architecture, an ornament placed at the intersection of the ribs or groins in vaulted or flat

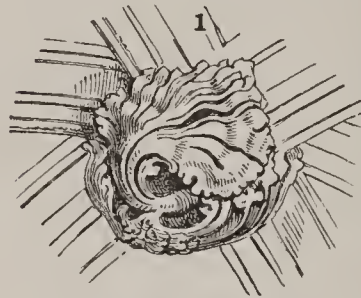

Boss—Wells Cathedral.

roofs; it is frequently richly sculptured with armorial bearings or other devices.

**Bossuet** (bos-û-ā), JACQUES BÉNIGNE, illustrious French preacher and theologian, was born in 1627, died in 1704. At the age of fifteen he entered the College of Navarre, where he studied Greek and the Holy Scriptures, read the ancient classics, and investigated the Cartesian philosophy. In 1652 he was ordained priest, and made a canon of Metz, where his piety, acquirements, and eloquence, gained him a great reputation. In 1670 he was appointed preceptor to the Dauphin, and in 1681 he was raised to the see of Meaux. He drew up the famous propositions adopted by the assembly of French clergy, which secured the freedom of the Gallican Church against the aggressions of the pope. In his latter years he opposed Quietism, and prosecuted Madame Guyon; and when his old friend Fénelon defended her he caused him to be



## BOSTANJI — BOSTON.

exiled. He was unrivalled as a pulpit orator, and greatly distinguished for his strength and acumen as a controversialist. The great occupation of his life was controversy with the Protestants.

**Bostan'ji** (Turk., from *bostan*, a garden), a class of men in Turkey, originally the sultan's gardeners, but now also employed in several ways about his person, as mounting guard at the seraglio, rowing his barge,

&c., and likewise in attending the officers of the royal household.

**Bos'ton**, a municipal and parliamentary borough and port of England, in Lincolnshire, on the Witham, about 5 miles from the sea. The name stands for Botolph's town, St. Botolph having founded a monastery here about the year 650. The trade is increasing through the improvement of the accommodation for shipping. The town



View in the Bosphorus.

contains some fine buildings, the parish church being a very large and handsome Gothic structure, with a tower nearly 300 feet high. Ropes, sails, agricultural implements, &c., are made. The town sends one member to Parliament. Pop. of mun. bor. 14,593; of parl. bor. 18,927.

**Boston**, in the United States, the capital of Massachusetts, and the largest city in New England, lies 234 miles N.E. from New York, on Massachusetts Bay, at the mouth of Charles River. It has a capacious harbour, covering 75 sq. miles, protected from storms by a great number of islands, on several of which are fortifications. The scenery is varied and picturesque; the site partly consists of peninsulas, East Boston being on an island. The streets are mostly narrow and irregular in the older parts of the town, but in the newer parts are many fine spacious streets. There are many small

parks, and a series of connecting parks is in process of formation; at present the Common and the Public Garden in the heart of the city are the chief pleasure-grounds. Among the principal buildings are the state-house; the county court-house; the post-office; Faneuil Hall (from Peter Faneuil, who presented it to the city in 1742), famous historically as the meeting-place of the revolutionary patriots; the city-hall or old state-house, now used as public offices; the splendid granite custom-house, of Grecian architecture; public halls, theatres, &c. Harvard University, situated at Cambridge, which may be regarded as a Boston suburb, was founded in 1638. The library has 292,000 vols. The medical branch of this institution is in Boston. The Boston Athenæum has two large buildings—one containing a library, and the other a picture-gallery, a hall for public lectures, and other rooms

## BOSTON — BOSWELL.

for scientific purposes. The library consists of about 174,000 vols. Boston University, founded principally by Isaac Rich, and incorporated in 1869, consists of the college of liberal arts; college of music; college of agriculture; school of theology; school of laws; school of medicine; and the school of all sciences. It is as open to women as to men: average number of students, 600. A prominent feature in Boston is the number of

the War of Independence it played an important part. It was here that the opposition to the British measures of colonial taxation were strongest. The defiance reached its height when the Stamp Act was repealed, and the Tea Act denounced by three cargoes being thrown into the harbour. Here the battle of Bunker Hill was fought, June 17, 1775. Pop. 1890, 448,477.

**Boston, THOMAS**, a Scottish divine, born at Dunse 1677, died 1732. He was educated at Edinburgh University, received license to preach in 1697, and in 1707 was appointed to the parish of Ettrick in Selkirkshire, where he remained all his life. Besides engaging hotly in the ecclesiastical controversies of his time, Boston published a volume of sermons, several theological treatises, and his two well-known works, *The Crook in the Lot* and *Human Nature in its Fourfold State*.

**Bos'well, JAMES**, the friend and biographer of Dr. Johnson, was the eldest son of Lord Auchinleck, one of the supreme judges of Scotland. He was born at Edinburgh in



good libraries. Besides those already mentioned, there is the Public Library, founded in 1852, which already contains 556,283 vols.; the State Library, with 50,000 vols.; and others. Boston carries on an extensive home and foreign trade, and is also largely engaged in the fisheries. Many manufactures are carried on, one of the principal being that of boots and shoes. The first American newspaper was set up here in 1704. The book-trade of the city is important, and some of the periodicals are extensively circulated. Boston was founded in 1630 by English emigrants, and received its name from Boston in Lincolnshire, whence several of the settlers had come. Notwithstanding its increasing size and importance, the affairs of Boston for nearly two hundred years were administered by the town's-people assembled in 'town's meeting.' In

1740, and died in London in 1795. He was educated at Edinburgh and Cambridge, became a member of the Scottish bar, but never devoted himself with earnestness to his profession. In 1763 he became acquainted with Johnson—a circumstance which he himself calls the most important event of his life. He afterwards visited Voltaire at Ferney, Rousseau at Neufchâtel, and Paoli in Corsica, with whom he became intimate. In 1768, when Corsica attracted so much attention, he published his account of Corsica, with *Memoirs of Paoli*. In 1785 he settled at London, and was called to the English bar. Being on terms of the closest intimacy with Johnson, he at all times diligently noted and recorded his sayings, opinions, and actions, for future use in his contemplated biography. In 1773 he accompanied him on a tour to the Scottish

Highlands and the Hebrides, and he published an account of the excursion after their return. His *Life of Samuel Johnson*, one of the best pieces of biography in the language, was published in 1791. His son ALEXANDER, born in 1775, created a baronet in 1821, killed in a duel in 1822, excelled as a writer of Scotch humorous songs, and was also a literary antiquary of no inconsiderable erudition.

**Boswel'lia**, a genus of balsamic plants belonging to the myrrh family (*Amyridaceæ*), several species of which furnish the frankincense of commerce, more generally known as *olibanum*. Indian *olibanum* is got from *Boswellia thurifera*, a large timber tree found in the mountainous parts of India.

**Bos'worth**, a small town in the county of Leicester, England, about 3 miles from which is Bosworth Field, where was fought, in 1485, the battle between Richard III. and the Earl of Richmond, afterwards Henry VII. This battle, in which Richard lost his life, put a period to the Wars of the Roses. Bosworth gives name to a parl. div. of the county. Pop. 1149.

**Bosworth**, JOSEPH, English philologist, born in Derbyshire 1790, died 1876. He was ordained deacon in 1814, and after filling several livings in England was British chaplain at Amsterdam and Rotterdam for twelve years. He devoted much time to researches in Anglo-Saxon and its cognate dialects, the result of his studies appearing from time to time. His chief works are his *Anglo-Saxon Grammar*; *Dictionary of the Anglo-Saxon Language*; and *Compendious Anglo-Saxon and English Dictionary*. In 1857 he was presented to the rectory of Water Shelford, Buckingham, and next year was appointed Rawlinson Professor of Anglo-Saxon at Oxford. He was M.A. and LL.D. of Aberdœn; Ph.D. of Leyden, and D.D. of Cambridge. In 1867 he gave £10,000 to establish a professorship of Anglo-Saxon at Cambridge.

**Bot**, BOTR. See *Bot-fly*.

**Botan'ic Gardens**, establishments in which plants from all climates are cultivated for the purpose of illustrating the science of botany, and also for introducing and diffusing useful or beautiful plants from all parts of the world. Until modern times their sole design was the cultivation of medicinal plants. In Britain the chief gardens are those of Kew (which see), Edinburgh, and Dublin. On the European continent the chief are the *Jardin des Plantes* at Paris,

founded 1634; and those of Berlin, Copenhagen, Florence, &c. In America the chief are those of New York, Philadelphia, and Cambridge.

**Botany** (Gr. *botanē*, herb, plant), or PHYTOLOGY (Gr. *phyton*, plant, and *logos*, discourse), is the science which treats of the vegetable kingdom.

Plants may be studied from several different points of view. The consideration of their general form and structure, and the comparison of these in the various groups from the lowest to the highest, constitutes *morphology*. *Anatomy* and *histology* treat respectively of the bulkier and the more minute internal structure of the parts, and *physiology* of their functions. *Systematic botany* considers the arrangement of plants in groups and sub-groups according to the greater or less degree of resemblance between them. *Geographical botany* tells of their distribution on the earth's surface, and strives to account for the facts observed, while *palæobotany* bears the same relation to distribution in the successive geological strata which make up the earth's crust. *Economic botany* comprises the study of the products of the vegetable kingdom as regards their use to man.

The simplest plants are very minute, and can only be studied by use of the compound microscope. A little rain-water which has been standing some time when thus examined is found to contain a number of roundish green objects, each of which is an individual plant, consisting of one cell only, with an external limiting membrane or cell-wall of a substance known as *cellulose*, within which is granular, viscid *protoplasm*. The protoplasm is permeated by a green colouring matter, *chlorophyll*, and embedded in it is an oval, more solid-looking body, the *nucleus*. *Protococcus*, as this little plant is called, though so simple, is yet able, by virtue of the living protoplasm, to take up food from the water around it; to work that food up into more cellulose and protoplasm so as to increase in size; and, finally, to produce new individuals, more *Protococci*. If we imagine *Protococcus* to elongate considerably and be repeatedly divided across by cell-walls, we get a row or filament of cells, a very common form among the low orders of plants: the masses of green threads seen floating in ditches in the spring and summer consist of such a filamentous plant called *Spirogyra*. Or we may have a single flat sheet of cells, as in the delicate green

sea-weed *Ulva*. Increased complexity of structure is exemplified in many of the ordinary sea-weeds, the stalk and more or less flattened expansions of which are several to many cells thick, the external cell-layers differing somewhat in structure from the internal. But we cannot distinguish in any of these between a stem, leaf, or root, as we can for instance in the more highly differentiated fern. Plants in which such a distinction cannot be drawn are called *Thallophytes*, and their whole body a *thallus*. Thallophytes can be divided into two classes: *Algæ* and *Fungi*. The former are distinguished by the presence of the green colouring matter chlorophyll, which is of vital importance in the physiology of the plant; sometimes the green colour is obscured by the presence of a brown or red compound, as in the brown and red sea-weeds. The *Fungi* contain no chlorophyll, and also differ in being composed not of expansions or masses of cells like the algæ, but of numbers of delicate interlacing tubes or *hyphæ*, often forming, as in the mushroom, quite large and complicated structures. *Lichens* are an interesting class between *Algæ* and *Fungi*, inasmuch as they are built up of an alga and a fungus, which live together and are mutually dependent on each other.

Going a step higher we reach the *Mosses*, where, for the first time, we distinguish a clear differentiation of the part of the plant above ground into a stem and leaves borne upon it. The stem is attached to the soil by delicate colourless hairs—*root-hairs*. Its structure is, however, very simple, and the leaves are merely thin plates of cells. Rising still higher to the fern-like plants, including *Equisetums* (Horse-tails) and *Lycopods* (Club-mosses), we notice a great advance in complexity both of external form and internal structure. The leaves are large, often much branched, the stem stout and firm, while instead of the few simple hairs which was all the indication of a root-system to be found in the moss, there are well-developed true roots. Microscopic examination of sections of stem, leaf, or root, shows great differences in structure between various groups of cells; there is, in fact, marked *differentiation of tissues*. A tissue is a layer, row, or group of cells which have all undergone a similar development; by *differentiation of tissues* we mean that various layers, rows, or groups have developed in different ways, so that we can make out and mark by distinctive names the elements

of which a stem or leaf is built up. The structure of thallophytes and mosses is very simple, but in the ferns, besides other well-marked tissues, we meet with one of so great importance in the higher plants, and so constantly present, that it is used as a distinctive characteristic of all the plants above the mosses. Ferns and flowering-plants which contain this *vascular tissue* are known as *vascular plants*, in contrast to the thallophytes and mosses, or *cellular plants*, where it is not found. Microscopical examination of a very thin longitudinal slice of the stem, root, or leaf-stalk of a vascular plant shows bundles of long cells running lengthwise, the walls of which are not uniformly thin, as in the cells making up the groundwork of the portion examined, but are covered with curious markings which are seen to represent local thickenings of the walls, thin places, or *pits*, being left between them. These cells, which are quite empty, are the wood-cells; they are placed end to end, and when, as frequently occurs, the end-walls separating the cavities of two cells become absorbed, a wood *vessel* is formed. Near the elements of the wood, but differing greatly from them in their delicate unchanged walls and thick viscid contents, are the *bast-vessels*, or *sieve-tubes*, so called from the end-to-end communication between two cells being established, not by absorption of the whole wall, but by its perforation at numerous spots forming a sieve arrangement. This combination of wood and bast vessels forms the essential part of what is therefore known as vascular tissue.

*Phanerogams*, or *Flowering-plants*, represent the highest group of plants: *Seed-plants* would be a better name, as their main distinction from those already described is the production of a *seed*. The much greater variety in form and structure seen in them as compared with the ferns justifies us in regarding them as the highest group in the vegetable kingdom. They are divided into two classes. (1) Those in which the seed is developed on an open leaf, termed a carpel, and called therefore *Gymnosperms* (Gr. *gymnos*, naked, and *sperma*, seed); and (2) those in which the seed is developed in a closed chamber, formed by the folding together of one or more carpels, and called accordingly *Angiosperms* (Gr. *angeion*, vessel). To the former belong the *Conifers*—pines and firs—and *Cycads*; to the latter the rest of our trees and the enormous number of field and

garden plants which are not ferns or mosses. Angiosperms again are subdivided into *Monocotyledons*, where the embryo or young plant contained in the seed has only one primary leaf; and *Dicotyledons*, where an opposite pair of such leaves is present. Like the last group, Phanerogams are differentiated into a shoot-portion above the ground, consisting of a stem bearing leaves, and a subterranean root-portion. Both stem and root are often copiously branched, so that one individual may cover a large area both above and below ground. Stem, leaves, and roots all show great variety in form and adaptation.

The embryo, or rudimentary plant contained in the seed, consists of a very short axis or stem, bearing one (in *Monocotyledons*), two (in *Dicotyledons*), or several (in many *Gymnosperms*) primary leaves, the *cotyledons*, above which it terminates in a little bud or *plumule*, while below them the axis passes into the primary root or *radicle*. When the seed germinates the radicle is the first to protrude between the separating seed-coats, and growing downwards fixes itself in the soil. Then the plumule grows out accompanied or not, as the case may be, by the cotyledons, which have hitherto concealed and protected it, and by rapid growth soon develops into a stem bearing leaves. The stem continues growing in length at its apex throughout the life of the plant; at a short distance below the apex growth in length ceases; but while in *Gymnosperms* and *Dicotyledons* it also continually increases in thickness through its whole length, *Monocotyledons* are distinguished by the fact that when once the stem has been formed its diameter remains unchanged. The same rule applies to the branches. The cause of this difference is found in the internal structure. In the *Gymnosperm* and *Dicotyledon* a transverse section in a very young stage has the following appearance: Starting from the outside we have, (1) a single protective layer of cells with thick external walls, the *epidermis*. (2) Inside this, and forming what is called the *cortex*, are a number of thin-walled cells arranged like bricks in a wall, or touching only at their rounded edges, and leaving intercellular spaces. Such an arrangement, where there is no dove-tailing between the cells, is called *parenchymatous*. (3) Within the cortex a ring of vascular bundles, each consisting essentially of a little group of bast-vessels towards the outside and wood-vessels on the inside, separated by a single

layer of cells, the *cambium-layer*. (4) Within the ring of bundles the *pith*, of parenchyma like the cortex, and united to it by strands of similar parenchymatous cells passing between the bundles and known as *medullary rays*. As the young stem grows, however, the spaces between the bundles are filled up by development of fresh bast, cambium, and wood, so that instead of a number of separate bundles there is a *complete* vascular ring. The cambium-ring remains in active growth throughout the whole life of the plant, and by producing new bast on the outside and wood on the inside causes continual increase in thickness. The epidermis, which would of course soon give way beneath the strain of the growth inside, is replaced as a protective layer by the *bark*, development of which keeps pace with increase in diameter. Now in the young *monocotyledonous* stem, instead of a few bundles arranged in a ring separating pith from cortex, a great number are scattered through the whole internal parenchymatous tissue, so that we cannot distinguish any pith at all. The bundles, moreover, have no cambium-layer, so that when once formed their development is complete, and there is no increase in thickness. Stems, which may be *simple* or *branched*, are either *aërial* or *subterranean*. *Aërial* forms are, (1) *erect*, as the trunks of trees, or the more slender stems of most herbaceous plants, or the hollow *culms* of grasses. (2) *Prostrate*, as the creeping *runners* of the strawberry; or, (3) *Climbing*, in which case they may either twine round a support, like the hop; or hold on by means of *prickles*, like the bramble; or more usually by *tendrils*, as in the vine; or, finally, by *root-fibres* given off from the stem, as in the ivy. Examples of subterranean stems are, (1) the *rhizome*, a horizontal stem sending forth aërial shoots from its upper and roots from its lower surface; (2) the *tuber*, a much-swollen fleshy stem, like the potato, the eyes of which are buds; (3) the *bulb*, a very short undeveloped stem with crowded overlapping leaves, as the onion.

*Branches* proceed from buds which are formed in the autumn in the axils of the leaves, that is, at the point where the leaf or leaf-stalk is joined on to the stem; they remain dormant through the winter, and grow out into new shoots in the spring.

The *leaf* is borne on the stem; its tissues, epidermal, cortical, and vascular, are continuous with those of the stem; but it is

distinguished by the fact that its growth is limited, it soon reaches the normal size and stops growing. The places where leaves come off from the stem are called *nodes*. There is great variety both in the position and form of leaves. Their *position* is said to be *radical* when they are all borne close together at the base of the stem, as in the dandelion; or *cauline*, when they are borne on the upper parts; in the latter case they may have a *whorled* arrangement, where several come off at the same level in a circle round the stem, as in the herb Paris; or *opposite*, where two stand on opposite sides at each node, as in the gentians; or *alternate*, where only one comes off at the same level. The study of leaf arrangement is known as *phyllotaxy*. A leaf may be *stalked* or *sessile*; if sessile, the blade is joined directly on to the stem. The stalk is known as the *petiole*, the flattened expanded blade as the *lamina*. The leaf may be *simple* or *compound*. A simple leaf cannot be divided without tearing the lamina; while a compound leaf is made up of independent leaflets, which may all come off from the same point as in the horse-chestnut, which is the *digitate* form; or may be arranged along a continuation of the petiole, as in the ash, which is the *pinnate* form of a compound leaf. The tissue of the lamina is traversed by vascular bundles, which are continuous through the petiole with those of the stem. The infinite variety of their ramifications is the cause of the often very characteristic *venation* of the leaves. Leaves are said to be *deciduous* when they fall annually, as they do in the most common forest-trees; or *persistent* when they last longer, as in the firs, laurels, &c. Leaves of phanerogams are often very much modified or *metamorphosed*; thus the spines of the cactus are metamorphosed or modified leaves, as are also several forms of those curious leaf-growths known as pitchers, and many tendrils, such as those of the pea tribe. When we consider the flower we shall find that its various members are all more or less modified leaves.

In Dicotyledons and Gymnosperms the primary *root* or radicle after emerging from the seed continues to grow vigorously, often with copious lateral branching, forming an extensive root-system; but in Monocotyledons it soon perishes, and its place is taken by roots developed from the base of the stem, such roots are called *adventitious*. Adventitious roots occur also in Dicoty-

ledons, as in creeping stems like the strawberry, which bears buds at intervals from which new shoots are formed and roots given off. The clinging roots of the ivy are also adventitious. There are many forms of roots: some are large and woody, as those of trees; others fibrous, as in grasses; or they may be greatly swollen, forming the fleshy globose root of the turnip, or the conical one of the carrot. Such fleshy developments are due to the plant storing up a quantity of reserve food-material in the first year on which to draw in the second, when it will want to expend all its energy in flowering and fruiting. The potato, which is a swollen stem, answers the same purpose. The mistletoe and other parasites give off sucker-like roots which penetrate into the tissues of their host.

As to their *reproduction*, plants may be *asexual*, that is, not requiring the co-operation of two distinct (male and female) elements to produce a new individual; or *sexual*, when two such elements are necessary, and a process of fertilization takes place in which the female cell is impregnated by one or more male cells, and the cell resulting from the fusion of the two gives rise by very extensive growth and division to a new individual. In the very lowest plants, like Protococcus, only asexual reproduction is known, but in most Thallophytes both forms occur. In the asexual method numbers of small cells called *spores* are produced which on germination give rise to a plant similar to that which bore them. In the sexual process the contents of a male organ escape and impregnate the *oosphere*, or female cell contained in the female organ. The fertilized oosphere is termed an *oospore*, and by growth and division gives rise to a plant like that on which it was produced. In mosses and fern-like plants both sexual and asexual reproduction occur; but here the history of the life of the plant is divided into two stages, one in which it exists as an asexual individual, another in which it is sexual. In the fern, for instance, brown marks are seen on the back of some of the leaves, these are little cases containing spores; the fern as we know it is an asexual individual producing spores. The spores when set free germinate on a damp surface and produce *not* a new fern-plant, but a tiny green heart-shaped cellular expansion, called a *prothallium*, attached to the substratum by delicate root-hairs. Microscopical examination of its under surface reveals the sexual

## BOTANY.

organs, a male organ producing motile male cells, which escape, pass into the female organ, and fertilize the oosphere, which then becomes the oospore. The oospore does not produce a new prothallium, but a fern-plant like the one with which we originally started. The cycle is thus complete.

The *flower* of a seed-plant is a shoot modified for purposes of reproduction. A buttercup, for instance, consists of a number of modified leaves borne in several whorls on the somewhat expanded top of the stalk, the *receptacle* or *thalamus*. Dissection of the flower shows (1) An outer whorl of five green leaves, very like ordinary foliage leaves; these are the *sepals*, and together make up the *calyx*. (2) An inner whorl of five yellow leaves, composing the *corolla*, each leaf being a *petal*. (3) More or less protected by the petals are a great number of *stamens*, each consisting of a slender stalk or *filament* capped by an *anther*, a little case containing the dry powdery *pollen*. The stamens are really much-modified leaves; collectively they form the *androcium*. (4) The rest of the receptacle right up to the apex is also covered by very much modified leaves, the *carpels*, forming the *pistil* or *gynœcium*. Each carpel consists of a basal portion, the *ovary*, in which is contained an *ovule*, and of a terminal beak-like portion, the *style*. The androcium and gynœcium, being the parts directly concerned in reproduction, are distinguished, as the *essential* organs of the flower, from the calyx and corolla, which are only indirectly so concerned, though of great importance in the process. The ovule contained in the ovary is equivalent to the spore produced by the fern, but instead of escaping and producing an independent sexual individual it remains in the ovary, where processes go on *within* it corresponding to those resulting in the formation of the free and independent prothallium of the fern, and finally an oosphere is produced. Pollen from the stamen of the same or another plant has meanwhile been brought on to the special receptive portion of the style known as the *stigma*, where it protrudes a long tube which reaches right down through the style to the ovule. This tube represents the male element; it comes into close contact with the oosphere and fertilizes it. The oosphere then becomes an oospore, which by growth and division forms the *embryo* or new plant, while still included in the coats of the ovule. The ovule thus be-

comes the seed, which ultimately leaves the mother plant, bearing with it the embryo.

In the buttercup the members of each whorl of leaves composing the flower spring from the receptacle quite independently of each other, and of those of adjoining whorls. In many flowers, however, *cohesion* takes place between the similar members of a whorl; thus the petals frequently cohere to a greater or less distance from their base, and two great divisions of the Dicotyledons depend on this condition, namely, *Poly-petale*, where the petals are free, as in the buttercup and poppy; and *Gamopetale*, with more or less coherent petals, as in the bluebell and primrose. Similarly the gynœcium, instead of being composed of free carpels as in the buttercup, the *apocarpous* condition, may be formed by the cohesion of several carpels into a one to several chambered *compound* ovary, as in the snapdragon, when it is said to be *syncarpous*. *Adhesion* also occurs between members of different whorls; thus the stamens are frequently inserted on the base of the petals, so that if we pull off a petal a stamen comes with it; and sometimes, as in orchids, the androcium and gynœcium are adherent. If the other floral whorls are inserted on the receptacle beneath the pistil they are said to be *hypogynous* and the pistil *superior*, as for instance in the poppy; if, on the other hand, as in the fuchsia, they spring from the top of the ovary, they are said to be *epigynous* and the pistil *inferior*.

An important characteristic is the *fruit*, which is the result of fertilization on the ovary. While the changes are going on by which the ovule becomes the seed the ovary also grows, often enormously, and forms the *pericarp*, which surrounds and protects the seed or seeds. The pericarp consists of an outer layer or *epicarp*, a middle layer or *mesocarp*, and an inner or *endocarp*. The outer usually forms the skin of the fruit; the two others may be succulent as in the berry, or the mesocarp only may be succulent and the endocarp hard and stony as in the plum. Besides the embryo the seed contains a store of food-material on which the young plant feeds during the first stages of its growth. This consists of albuminous, starchy, or fatty matter. In what are called *albuminous* seeds, as those of palms, the seed is chiefly composed of food-material in which is embedded a small embryo; the edible part of a cocoa-nut is the albuminous reserve-material. In other seeds, like the

bean, the fleshy cotyledons have already absorbed this food-material into themselves, and the seedling draws on its own cotyledons for support; these seeds are known as *exalbuminous*.

It was stated above that the ovule might be fertilized by pollen from the same flower or from another plant; experiment has shown that the latter produces better results, both as regards quality and quantity of seed, and the vigour of the seedlings. That is, *cross-fertilization* is preferable to *self-fertilization*, and the various, often extremely curious, shapes of a flower and its parts are mainly for the purpose of ensuring the former and preventing the latter.

Many flowers contain both stamens and pistil, these are termed *bisexual* or *hermaphrodite* (♂); while others contain stamens or pistil only, such are said to be *unisexual*. When both male (♂) and female (♀) flowers occur on the same plant the species is *monœcious*, like the hazel; while it is *diœcious* if the separate sexes are borne on different individuals, as is the case in the hop.

Plants which, like the sunflower, pass through all the stages from germination to production of fruit and seed in one season, and then perish, are called *annuals*; if two years are required, as with the turnip and onion, they are *biennials*; while *perennials* last several to many years, during which they may flower and seed many times.

*Physiology*.—A plant is built up chiefly of four elements: carbon, hydrogen, oxygen, and nitrogen, with small quantities of sulphur and phosphorus and some mineral matter. Substances containing these must therefore form the food. A green plant can take up its carbonaceous food in a very simple form by means of the green *chlorophyll* contained especially in its leaves. This absorbs some of the sun's rays, and by virtue of the energy represented by the light so absorbed it can obtain the carbon from the carbonic acid gas present in the atmosphere. An animal, having no chlorophyll, has to use more complex carbon-containing compounds, in fact those which have already been worked up in the vegetable kingdom. The other items of the food are obtained from the water and mineral salts in the soil, the salts being brought into solution and absorbed with large quantities of water by the roots. The leaves are the laboratory where the food is worked up into the complex compounds which form the plant sub-

stance, and to raise the crude material from the absorbing roots to the leaves there is an upward current of liquid through the stem. This is known as the *transpiration current*; it travels in the wood-cells. A much larger quantity of water is absorbed than is required as food; this is got rid of by *transpiration*, that is, by the giving off of water-vapour from the leaves. This is evident if a plant be placed under a glass shade in the sunlight, the vapour given off becoming condensed on the glass. The complex compounds elaborated in the leaves are returned to all parts of the plant where growth, or storage of reserve-material, is taking place, by means of the other constituent of the vascular bundle, the bast tissue.

Fungi and a few seed-plants contain no chlorophyll and cannot therefore get their carbonaceous food from the carbonic acid gas of the atmosphere, but have to live on decaying vegetable or animal matter, when they are termed *saprophytes* (Greek *sapros*, rotten), like mushrooms, or on living plants or animals, when they are *parasites*; such are the fungi which cause diseases in these organisms. Plants, like animals, breathe; respiration goes on both day and night, and is represented by the absorption of oxygen from, and the return of carbonic acid gas to the atmosphere. If we prevent a plant from breathing, that is keep it in an atmosphere containing no free oxygen, it will sooner or later die.

*Systematic Botany*.—In botany, as in zoology, individuals which closely resemble each other form collectively a *species*. Where existing differences are considered too minute to constitute difference of species the set of individuals in which they occur ranks as a *variety* of the species. Species which, though having each some distinctive peculiarity, yet on the whole resemble each other, constitute a *genus*. Assemblages of genera agreeing in certain marked characters form *families* or *natural orders*. The names of the orders are generally formed on the type of *Rosaceæ*, the rose order, *Ulmaceæ*, the elm order, &c. *Classes*, such as *Monocotyledons* and *Dicotyledons*, contain a large number of natural orders. The older systems of classification were based largely on the uses of plants, for they were studied simply from a medicinal or generally economic point of view. In 1682, however, John Ray discovered the difference between *Monocotyledons* and *Dicotyledons*, and pub-



BOTANY BAY — BOTHNIA.

lished an arrangement of plants founded on their structural forms, especially on the characters afforded by the seed; this formed the basis of the *natural* system of classification, one, that is, which brings together those genera and families which a careful comparative study of the whole structure and development shows to be most nearly related. Linnæus did not recognize Ray's great primary divisions, and his system (1735) is a purely *artificial* one, since it only takes account of a few marked characters afforded by one or two sets of organs, and does not propose to unite plants by their natural affinities. He divides Phanerogams into twenty-three classes, chiefly according to the number and character of the stamens; each class is subdivided into orders based on the number and character of the styles. Owing to the exclusive part played by the sexual organs this arrangement is known as the *sexual system*. The great value of Linnæus's work was his

careful scientific revision and adjustment of all the known genera, and his introduction of the binomial system of nomenclature, in which every species has a double name, that of the genus to which it belongs coming first, then that of the species; thus *Bellis perennis* L. is the daisy, and the name shows that the species *perennis* of the genus *Bellis* is the plant in question. The L. which follows indicates that we mean the plant so named by *Linnaeus*. The sexual system is now only of historic interest. By the sagacity of the Jussieus the genera of Linnæus were more or less naturally grouped under Ray's primary divisions; and by the subsequent labours of De Candolle, Robert Brown, Lindley, and many others we have attained to a fairly natural system, according to the latest edition of which, the *Genera Plantarum* of Bentham and Hooker, all our great collections are arranged.

The Angiosperms are subdivided as follows:—

Class I. MONOCOTYLEDONS.—Contains thirty-four natural orders arranged in seven series.

Class II. DICOTYLEDONS. Sub-class 1.—Polypetalæ (petals free).	}	Series 1. Thalamifloræ.—Stamens inserted on the thalamus. Contains thirty-three natural orders.
		2. Discifloræ.—Thalamus expanded within the calyx into a cup-like disc from which the stamens spring. Contains twenty-two natural orders.
		3. Calycifloræ.—Stamens epigynous, or inserted on the edge of the cup-like receptacle. Contains twenty-seven natural orders.
	2.—Gamopetalæ (petals united).	}
3.—Apetalæ (petals absent).	Contains thirty-six natural orders.	

**Botany Bay**, a bay in New South Wales, so called by Captain Cook on account of the great number of new plants collected in its vicinity. The English penal settlement, founded in 1788, and popularly known as Botany Bay, was established on Port Jackson, some miles to the northward, near where Sydney now stands.

**Botany Bay Oak**, a name of trees of the genus *Casuarina*. See *Beef-wood*.

**Botany Bay Resin**, akaroid resin.

**Botar'go**, a relish made of the salted roe of the mullet or tunny, used on the Mediterranean coasts.

**Botau'rus**, the bittern genus of birds.

**Bot-fly**, BOT-FLY, a fly (such as *Estrus equi*) the maggots of which are developed from the egg in the intestines of horses or under the skins of oxen; a gadfly.

**Both** (bôt), JOHN and ANDREW, two Flemish painters, born about 1610. John painted landscapes, Andrew filling in figures in so careful a manner that their pictures look like the work of one hand. Their works

are in great repute. Andrew was drowned at Venice in 1650. John died at Utrecht shortly after.

**Both'ie** (Gael. *bothag*, a cot), a house, usually of one room, for the accommodation of a number of work-people engaged in the same employment; especially, a house of this kind in parts of Scotland, in which a number of unmarried male or female farm servants or labourers are lodged in connection with a farm. Bothies are most common in the north-east of Scotland, and are chiefly for the accommodation of unmarried male farm servants engaged on the larger farms, who as a rule have to do their cooking and keep the bothie in order for themselves. The bothie system has often been condemned,

**Both'nia**, GULF OF, the northern part of the Baltic Sea, which separates Sweden from Finland. Length about 450 miles, breadth 90 to 130, depth from 20 to 50 fathoms. Its water is but slightly salt, and it freezes in the winter, so as to be passed by sledges and carriages.

**Bothrioceph'alus**, a genus of worms belonging to the tape-worm family, one species of which (*B. latus*) is found in the intestines of man in Russia, Norway, Sweden, Switzerland, Germany, &c., but rarely elsewhere.

**Both'well**, a village of Lanarkshire, Scotland, on the Clyde, 8 miles east of Glasgow. Here is Bothwell Bridge, where a decisive battle was fought in 1679 between the Scottish Covenanters and the royal forces commanded by the Duke of Monmouth, in which the former were totally routed. Near by are the fine ruins of Bothwell Castle, once a stronghold of the Douglases.

**Both'well**, JAMES HEPBURN, EARL OF, known in Scottish history by his marriage to Queen Mary, was born about 1526. It is believed that he was deeply concerned in the murder of Darnley, Mary's husband, and that he was even supported by the queen. He was charged with the crime and tried, but, appearing along with 4000 followers, was readily acquitted. He was now in high favour with the queen, and with or without her consent he seized her at Edinburgh, and carrying her a prisoner to Dunbar Castle prevailed upon her to marry him after he had divorced his own wife. But by this time the mind of the nation was roused on the subject of Bothwell's character and actions. A confederacy was formed against him, and in a short time Mary was a prisoner in Edinburgh, and Bothwell had been forced to flee to Denmark, where he died in 1576.

**Botocu'dos**, a Brazilian race of savages who live 70-90 miles from the Atlantic, in the virgin forests of the coast range. They receive their name from the custom which they have of cutting a slit in their under lip and in the lobes of their ears, and inserting in these, by way of ornament, pieces of wood shaped like the bung of a barrel (Portug. *botoque*). They are very skilful with the bow and arrow, and live chiefly by hunting. They number only a few thousands, and are decreasing.

**Botoshan'**, a town of Roumania, in the north of Moldavia. Pop. 39,941.

**Bo-tree**, the *Ficus religiosa*, pipal, or sacred fig-tree of India and Ceylon, venerated by the Buddhists and planted near their temples. One specimen at Anuradhapoora in Ceylon is said to have been planted before 200 B.C. It was greatly shattered by a storm in 1887.

**Botrychium** (bo-trik'i-um), a genus of

ferns, one species of which (*B. lunaria*, or common moonwort) is a native of Britain, growing on elevated heaths and pastures where other ferns are seldom found. *B. virginicum*, the largest species, is a native of North America, New Zealand, the Himalayas, &c.

**Botry'tis**, a genus of fungi, section Hyphomycetes, containing a number of plants known as moulds and mildews, some of them having the habit of growing in the tissues of living vegetables, to which they are extremely destructive. The decay of the leaves and stem in the potato disease is due to *B. infestans*; but whether this plant is the origin of the disease seems doubtful. The plants of the genus consist of a mycelium of interwoven threads.

**Botta**, PAUL ÉMILE, French traveller and archæologist, born about 1800. In 1833 he was appointed French consul at Alexandria. He undertook a journey to Arabia in 1837, described in his *Relation d'un Voyage dans l'Yémen*. He discovered the ruins of ancient Nineveh in 1843 while acting as consular agent for the French government at Mosul. As the result of his investigations he published two important works—one on the cuneiform writing of the Assyrians (*Mémoire de l'Écriture Cunéiforme Assyrienne*), and the other upon the monuments of Nineveh (*Monuments de Ninive*, five vols. folio, with drawings by Flandin, Paris, 1846-50)—the latter of which is a work of great splendour, and makes an era in Assyrian antiquities. He died in 1870.

**Böttger**, or BÖTTIGER (beut'gèr, beu'ti-gèr), JOHANN FRIEDRICH, German alchemist, the inventor of the celebrated Meissen porcelain, was born in 1682. His search for the philosopher's stone or secret of making gold led him into many difficulties. At last he found refuge at the court of Saxony, where the elector erected a laboratory for him, and forced him to turn his attention to the manufacture of porcelain, resulting in the invention associated with his name. He died in 1719.

**Botticelli** (bot-tè-chel'lē), SANDRO (for *Alessandro*), an Italian painter of the Florentine school, born in 1447, died 1515. Working at first in the shop of the goldsmith Botticello, from whom he takes his name, he showed such talent that he was removed to the studio of the distinguished painter Fra Lippo Lippi. From this master he took the fire and passion of his style, and added a fine fantasy and delicacy of his

own. He paints flowers, especially roses, with incomparable skill. In his later years Botticelli became an ardent disciple of Savonarola, and is said by Vasari to have neglected his painting for the study of mystical theology.

**Böttiger** (beu'ti-ger), KARL AUGUST, a German archæologist, born in 1760, died in 1835. After studying at Leipzig he became director of the gymnasium at Weimar, and it was here that, while he enjoyed the society of Goethe, Schiller, Wieland, and other distinguished men, he began his literary career. In 1814 he was appointed chief inspector of the Museum of Antiquities in Dresden, where he continued to reside to the end of his life. Among his most important works are: *Sabina, oder Morgen-scenen einer reichen Römerin* (Sabina, or Morning Scenes of a Wealthy Roman Lady); *Griechische Vasengemälde* (Paintings on Greek Vases); *Ideen zur Archæologie der Malerei* (Thoughts on the Archæology of Painting).

**Bottle**, a vessel of moderate or small size, and with a neck, for holding liquor. By the ancients they were made of skins or leather; they are now chiefly made of glass or earthenware. The common black bottles of the cheapest kind are formed of the most ordinary materials, sand with lime, and sometimes clay and alkaline ashes of any kind, such as kelp, barilla, or even wood ashes. This glass is strong, hard, and less subject to corrosion by acids than flint-glass.

**Bottle-flower.** See *Blue-bottle*.

**Bottle-gourd**, a kind of gourd, genus *Lagenaria*, the dried fruits of which, when the pulp is removed, are used in warm countries for holding liquids.

**Bottle-nose**, a kind of whale, of the dolphin family, genus *Hyperoödon*, 20 to 28 feet long, with a beaked snout and a dorsal fin, a native of northern seas. The caaing-whale is also called bottle-nose.

**Bottle-tree** (*Delabechea rupestris*), a tree of North-eastern Australia, order Sterculiaceæ, with a stem that bulges out into a huge rounded mass. It abounds in a nutritious mucilaginous substance.

**Bot'tomry** is a contract by which a ship is pledged by the owner or master for the money necessary for repairs to enable her to complete her voyage. The freight and even the cargo may be pledged as well as the ship. The conditions of such a contract usually are that the debt is repayable only

if the ship arrives at her destination. As the lender thus runs the risk of her loss, he is entitled to a high premium or interest on



Bottle-tree (*Delabechea rupestris*).

the money lent. The latest bottomry bond takes precedence of all previous ones.

**Bot'zen**, or **BOLZA'NO**, an old town in the Austrian Tyrol, well built, at the junction of roads from Switzerland, Germany, and Italy, which makes it an important forwarding station and the busiest town in the Tyrol. It has silk and cotton manufactures, tanneries, dye-works, and largely-attended annual fairs. Pop. 10,641.

**Bouches-du-Rhône** (bösh-dü-rön; 'Mouths of the Rhone'), a dep. in the s. of France, in ancient Provence. Chief town, Marseilles. Area, 1,267,088 acres, of which about one-half is under cultivation. The Rhone is the principal river. The climate is generally very warm; but the dep. is liable to the *mistral*, a cold and violent N.E. wind from the Cevennes ranges. Much of the soil is unfruitful, but the fine climate makes the cultivation of figs, olives, nuts, almonds, &c., very successful. The manufactures are principally soap, brandy, olive-oil, chemicals, vinegar, scent, leather, glass, &c. The fisheries are numerous and productive. Pop. 1891, 630,622.

**Boucicault** (bö'si-kō), DION, dramatic author and actor, born at Dublin Dec. 20, 1822, and educated partly at London University. He was intended for an architect, but the success of a comedy, the well-known London Assurance, which he wrote when only nineteen years old, determined him for a career in connection with the stage. Boucicault being a remarkably facile writer, in a few years had produced quite a lengthy list of pieces, both in comedy and

melodrama, and all more or less successful. We may mention *Old Heads and Young Hearts*, *Love in a Maze*, *Used Up*, the *Corsican Brothers*. In 1853 he went to America, where he was scarcely less popular than in England. On his return in 1860 he produced a new style of drama, dealing largely in sensation but with more heart in it than his earlier work. The *Colleen Bawn* and *Arrah-na-Pogue* are the best examples. Indeed the best Mr. Boucicault can do may be seen in these pictures of Irish life and manners. As an actor he is clever, but not highly gifted. His dramatic pieces are said to number upwards of 150. Died 1890.

**Boudoir** (bö'dwār), a small room, elegantly fitted up, destined for retirement (from Fr. *bouder*, to pout, to be sulky). The boudoir is the peculiar property of the lady, where only her most intimate friends are admitted.

**Boufflers**, or **BOUFLERS** (bö-flār), LOUIS FRANÇOIS, DUC DE, Marshal of France, one of the most celebrated generals of his age, was born in 1644, died 1711. He learned the art of war under such renowned generals as Condé, Turenne, and Catinat. His defence of Namur against King William of England and of Lille against Prince Eugene are famous, and he conducted the retreat of the French at Malplaquet with such admirable skill as quite to cover the appearance of defeat.

**Bougainville** (bö-gañ-vēl), LOUIS ANTOINE DE, a famous French navigator, born at Paris in 1729. At first a lawyer he afterwards entered the army and fought bravely in Canada under the Marquis of Montcalm, and it was principally owing to his exertions, in 1758, that a body of 5000 French withstood successfully a British army of 16,000 men. After the battle of September 13, 1759, in which Montcalm was killed and the fate of the colony decided, Bougainville returned to France, and served with distinction in the campaign of 1761 in Germany. After the peace he entered the navy, and became a distinguished naval officer. In 1763 he undertook the command of a colonizing expedition to the Falkland Islands, but as the Spaniards had a prior claim the project was abandoned. Bougainville then made a voyage round the world, which enriched geography with a number of new discoveries. In the American war of independence he distinguished himself at sea, but withdrew from the service after the Revolution, and died in 1811.

**Bougainville Island** (see above), an island in the Pacific Ocean belonging to the Solomon group (area, 4000 sq. miles), and under German protection. It is separated from Choiseul Island by *Bougainville Strait*.

**Bougie** (bö-zhē), a fortified seaport on the coast of Algeria, well situated for trade, which it carried on in the middle ages to a greater extent than now, though under French rule it is again prosperous, exporting wax, honey, grain, &c. Pop. 12,167.

**Bougies** (bö'zhēz; the French word for tapers), in surgery applied to certain smooth cylindrical rods which are introduced into the canals of the human body in order to widen them, or more rarely to apply medicaments to a particular part in the interior of the body. They are distinguished from catheters by being quite solid. They are made sometimes of linen dipped in wax and then rolled up, sometimes of a kind of plaster and linen, also of caoutchouc or gutta-percha, or of metal, such as lead, silver, or German silver.

**Bouguer** (bö-gā), PIERRE, a French mathematician and astronomer, born in 1698. He was associated with Godin and La Condamine in an expedition to the South American equatorial regions to measure the length of a degree of the meridian. The main burden of the task fell upon Bouguer, who performed it with great ability, and published the results in his *Théorie de la Figure de la Terre*. He also invented the heliometer, and his researches about light laid the foundation of photometry. He died in 1758.

**Bouillon** (bö-yōñ), originally a German duchy, now a district in Belgium, 9 miles wide and 18 long, on the borders of Luxembourg and Liège, a woody and mountainous tract, with some 21,000 inhabitants. The small town of Bouillon was once the capital of the duchy, which belonged to the famous crusader Godfrey of Bouillon.

**Bouillon**, GODFREY. See *Godfrey of Bouillon*.

**Boulak'**, a town of Lower Egypt, a suburb and port of Cairo. It has cotton, sugar, and paper factories, and till recently had a famous museum of antiquities. Pop. 10,000.

**Boulder** (böl'dēr), a rounded water-worn stone of some size; in geol. applied to ice-worn and partially smoothed blocks of large size lying on the surface of the soil, or embedded in clays and gravels, generally differing in composition from the rocks in their vicinity, a fact which proves that they must have been transported from a distance, pro-

bably by ice. When lying on the surface they are known as *erratic blocks*. The *boulder-clay* in which these blocks are found belongs to the post-tertiary or quaternary period. It occurs in many localities, consists of a compact clay often with thin beds of gravel and sand interspersed, and is believed to have been deposited from icebergs and glaciers in the last glacial period.

**Boulevard** (böl-vär), a French word formerly applied to the ramparts of a fortified town, but when these were levelled, and the whole planted with trees and laid out as promenades, the name boulevard was still retained. Modern usage applies it also to many streets which are broad and planted with trees, although they were not originally ramparts. The most famous boulevards are those of Paris. See *Paris*.

**Boulogne** (bö-lon-yè or bö-lōn), or BOULOGNE-SUR-MER, a fortified seaport of France, dep. Pas de Calais, at the mouth of the Liane. It consists of the upper and lower town. The former is surrounded with lofty walls, and has well-planted ramparts; the latter, which is the business part of the town, has straight and well-built streets, and is semi-English in character, many of the sign-boards being in English, the shops having an English air, and much English being spoken. In the castle, which dates from 1231, Louis Napoleon was imprisoned in 1840. Boulogne has manufactories of soap, earthenware, linen and woollen cloths; wines, coal, corn, butter, fish, linen and woollen stuffs, &c., are the articles of export. Steamboats run daily between this place and England, crossing over in two or three hours. Napoleon, after deepening and fortifying the harbour, encamped 180,000 men here with the intention of invading Britain at a favourable moment; but, upon the breaking out of hostilities with Austria, 1805, they were called to other places. Pop. 1891, 45,205, about a tenth being English.

**Boulogne, BOIS DE.** See *Bois de Boulogne*.

**Boulogne-sur-Seine**, a town of France, dep. Seine, south-west of Paris, of which it is a suburb. It is from this place that the celebrated Bois de Boulogne gets its name. Pop. 1891, 32,569.

**Boulton** (bōl'ton), MATTHEW, a celebrated mechanic, was born at Birmingham in 1728, died there 1809. He engaged in business as a manufacturer of hardware, and invented and brought to great perfection

inlaid steel buckles, buttons, watch-chains, &c. In 1762 he added to his premises by the purchase of the Soho, a barren heath near Birmingham, where he established an extensive manufactory and school of the mechanical arts. The introduction of the steam-engine at Soho led to a connection between Boulton and James Watt, who became partners in trade in 1769.

**Bounty**, in political economy, is a reward or premium granted for the encouragement of a particular species of trade or production, the idea being that the development of such trade or production will be of national benefit. In Britain the idea of the inefficacy of bounties to sustain or develop commerce or manufactures is in general pretty well established, the usual argument being that it is nothing less than taxing the general community in order to encourage individuals to engage in businesses which, in the existing state of markets and competition, it would be better to leave alone. Hence the British government has long given up the system of bounties, except in such peculiar cases as the subsidies granted for carrying the oceanic mails.—The same name is given to a premium offered by government to induce men to enlist in the public service, especially to the sum of money given in some states to recruits in the army and navy. The highest bounty offered in Britain was during the wars with Napoleon, when it rose to about £24. During the civil war in America the bounty was at one time so high as \$900 (£180). The bounty given to army recruits in Britain was abolished by the Army Enlistment Act of 1870, but they are still allowed a free kit.

**Bouquetin** (bö'ke-tin). See *Ibex*.

**Bourbon** (bör-bōn), an ancient French family which has given three dynasties to Europe, the Bourbons of France, Spain, and Naples. The first of the line known in history is Adhemar, who, at the beginning of the 10th century, was lord of the Bourbonnais (now the dep. of Allier). The power and possessions of the family increased steadily through a long series of Archambaulds of Bourbon till in 1272 Beatrix, daughter of Agnes of Bourbon and John of Burgundy, married Robert, sixth son of Louis IX. of France, and thus connected the Bourbons with the royal line of the Capets. Their son Louis had the barony converted into a dukedom and became the first Duc de Bourbon. Two branches took their origin from the two sons of this Louis,

## BOURBON.

duke of Bourbon, who died in 1341. The elder line was that of the dukes of Bourbon, which became extinct at the death of the Constable of Bourbon in 1527, in the assault of the city of Rome. The younger was that of the counts of La Marche, afterwards counts and dukes of Vendôme. From these descended Anthony of Bourbon, duke of Vendôme, who by marriage acquired the kingdom of Navarre, and whose son Henry of Navarre became Henry IV. of France. Anthony's younger brother, Louis, prince of Condé, was the founder of the line of Condé. There were, therefore, two chief branches of the Bourbons—the royal, and that of Condé. The royal branch was divided by the two sons of Louis XIII., the elder of whom, Louis XIV., continued the chief branch, whilst Philip, the younger son, founded the house of Orleans as the first duke of that name. The kings of the *elder French royal line* of the house of Bourbon run in this way:—Henry IV. Louis XIII. XIV. XV. XVI. XVII. XVIII., and Charles X. The last sovereigns of this line, Louis XVI., Louis XVIII., and Charles X. (Louis XVII., son of Louis XVI., never obtained the crown), were brothers, all of them being grandsons of Louis XV. Louis XVIII. had no children, but Charles X. had two sons, viz. Louis Antoine de Bourbon, duke of Angoulême, who was dauphin till the revolution of 1830, and died without issue in 1844, and Charles Ferdinand, duke of Berry, who died, 14th Feb. 1820, of a wound given him by a political fanatic. The Duke of Berry had two children: (1) Louise Marie Thérèse, called Mademoiselle d'Artois; and (2) Henri Charles Ferdinand Marie Dieudonné, born in 1820, and at first called Duke of Bordeaux, but afterwards Count De Chambord, who was looked upon by his party until his death (in 1883) as the legitimate heir to the crown of France.

The branch of the Bourbons known as the *House of Orleans* was raised to the throne of France by the revolution of 1830, and deprived of it by that of 1848. It derives its origin from Duke Philip I. of Orleans (died 1701), second son of Louis XIII., and only brother of Louis XIV. A regular succession of princes leads us to the notorious Égalité Orleans, who in 1793 died on the scaffold, and whose son Louis Philippe was king of France from 1830 to the revolution of 1848. His grandson Louis Philippe, count de Paris, born 24th Aug.

1838, is the present head of the family, and since the death of Count de Chambord, the last male representative of the elder Bourbons, unites in himself the claims of both branches to the throne of France.

The *Spanish-Bourbon dynasty* originated when in 1700 Louis XIV. placed his grandson Philip, duke of Anjou, on the Spanish throne, who became Philip V. of Spain. From him descends the present infant occupant of the Spanish throne, Alphonso XIII., born in 1886.

The royal line of *Naples*, or the Two Sicilies, took its rise when in 1735 Don Carlos, the younger son of Philip V. of Spain, obtained the crown of Sicily and Naples (then attached to the Spanish monarchy), and reigned as Charles III. In 1759, however, he succeeded his brother Ferdinand VI. on the Spanish throne, when he transferred the Two Sicilies to his third son Fernando (Ferdinand IV.), on the express condition that this crown should not be again united with Spain. Ferdinand IV. had to leave Naples in 1806; but after the fall of Napoleon he again became king of both Sicilies under the title of Ferdinand I., and the succession remained to his descendants till 1860, when Naples was incorporated into the new kingdom of Italy.

**Bourbon, CHARLES, DUKE OF, or CONSTABLE OF BOURBON**, son of Gilbert, count of Montpensier, was born in 1489, and by his marriage with the heiress of the elder Bourbon line acquired immense estates. He received from Francis I., in the twenty-sixth year of his age, the sword of Constable, and in the war in Italy rendered important services by the victory of Marignano and the capture of Milan. After occupying for years the position of the most powerful and highly honoured subject in the realm he suddenly fell into disgrace, from what cause is not clearly known. But it is certain that the intrigues of the court party, headed by the king's mother and the Duke of Alençon, were threatening to deprive him both of honours and estates. The Constable, embittered by this return for his services, entered into treasonable negotiations with the Emperor Charles V. and the King of England (Henry VIII.), and eventually fled from France to put his sword at the service of the former. He was received with honour by Charles, who knew his ability, and being made general of a division of the imperial army, contributed greatly to the overwhelming defeat of Francis at Pavia. But the

Bourbon found that Charles V. was readier to make promises to him than to fulfil them, and he returned disappointed and desperate to the command of his army in Italy, an army nominally belonging to the emperor, but composed mostly of mercenaries, adventurers, and desperadoes from all the countries of Europe. Supplies falling short, and the emperor refusing to grant him more, the Constable formed the daring resolve of leading his soldiers to Rome and paying them with the plunder of the Eternal City. On May 6, 1527, his troops took Rome by storm, and the sacking and plundering continued for months. But the Bourbon himself was shot at the head of his soldiers.

**Bourbon, ISLE OF.** See *Réunion*.

**Bourbon**, a name commonly given to whiskey in the U. S.

**Bourbonnais** (bör-bon-ā), a former province of France, with the title first of a county, and afterwards of a duchy, lying between Nivernais, Berry, and Burgundy, and now forming the department of the Allier. See *Bourbon*.

**Bourbon-Vendée** (bör-bōn-vän-dā), NAPOLEON-VENDÉE, a French town, now LA ROCHE-SUR-YON.

**Bourchier, JOHN, LORD BERNERS.** See *Berners*.

**Bourdaloue** (bör-dā-lö), LOUIS, one of the great church orators of France, was born at Bourges in 1632, and entered the order of the Jesuits, becoming teacher of rhetoric, philosophy, and morals in the Jesuit college of his native place. In 1669 he entered the pulpit, and he preached for a series of years at the court of Louis XIV. with great success. The lofty and dignified eloquence with which he assailed the vices of contemporary society brought him fame even at a time when Paris was ablaze with the feasts of Versailles, the glory of Turenne's victories, and the masterpieces of Corneille and Racine. After the repeal of the Edict of Nantes (1686) he was sent to Languedoc in order to convert the Protestants, a task in which he was not unsuccessful. His sermons are amongst the classics of France. He died in 1704.

**Bourdon** (bör'don), a bass stop in an organ or harmonium having a droning quality of tone.

**Bourg** (börg), or BOURG-EN-BRESSE, a town of Eastern France, capital of the dep. of Ain, well built, with a handsome parish church, public library, museum, monuments to Bichat, Joubert, and Edgar Quinet, and

near the town the beautiful Gothic church of Brou, built in the early 16th century; some manufactures and a considerable trade. Pop. 12,534.

**Bourgelat** (börzh-lä), CLAUDE, creator of the art of veterinary surgery in France, born in 1712, died 1779. He established the first veterinary school in his native town in 1762, and his works on the art furnished a complete course of veterinary instruction.

**Bourgeois** (bur-jō'), a size of printing type larger than brevier and smaller than long-primer, used in books and newspapers.

**Bourgeoisie** (börzh-wä-zē), a name applied to a certain class in France, in contradistinction to the nobility and clergy as well as to the working-classes. It thus includes all those who do not belong to the nobility or clergy, and yet occupy an independent position, from financiers and heads of great mercantile establishments at the one end to master tradesmen at the other. It corresponds pretty nearly with the English term 'middle classes.' Etymologically the word refers to the old class of freemen or burghesses residing in towns.

**Bourges** (börzh), an ancient city of France, capital of the dep. of Cher, situated at the confluence of the Auron and Yèvre, 124 miles s. of Paris, formerly surrounded with ramparts, now laid out as promenades. It has crooked and gloomy streets, and houses built in the old style. The most noteworthy building is the cathedral (an archbishop's) of the 13th century, and one of the finest examples of Gothic in France. Bourges is a military centre and has an arsenal, cannon-foundry, &c., manufactures of cloth, leather, &c. Pop. 1891, 45,342.

**Bourmont** (bör-mōn), LOUIS AUGUSTE VICTOR DE GHAISNE, COMTE DE, Marshal of France, born in 1773; died in 1846. Entering the republican army he distinguished himself under Napoleon, who made him a general of division. After the restoration he readily took service with the new dynasty, and in 1830 commanded the troops which conquered Algiers, a success which gained for him the marshal's baton. After the revolution of 1830 he followed the banished Charles X. into exile, but latterly retired to his estate in Anjou, where he died.

**Bourne** (börn), VINCENT, an English scholar, born 1695, died 1747. In 1721, after graduating as M.A. at Cambridge, he became a master in Westminster School, where he remained, so far as is known, to the end of his life. He is one of the few who have

attained a kind of fame for writing Latin verse with a felicity and grace which might seem to rival those of the Roman poets themselves. His poems in Latin, which include original compositions and versions of English songs, epitaphs, &c., were first published in 1734. Cowper and Lamb translated various pieces of his.

**Bournemouth** (börn'-), a watering-place in Hampshire, having one of the best beaches in England. It has a fine climate and beautiful scenery, and has greatly increased in recent years. Pop. 37,650.

**Bournoise.** See *Burnoose*.

**Bourrienne** (bö-rē-ān), FAUVELET DE, a French diplomatist, was born in 1769, and educated along with Bonaparte at the school of Brienne, where a close intimacy sprang up between them. Bourrienne went to Germany to study law and languages, but returning to Paris in 1792 renewed his friendship with Napoleon, from whom he obtained various appointments, and latterly that of minister plenipotentiary at Hamburg. Notwithstanding that his character suffered from his being involved in several dishonourable monetary transactions, he continued to fill high state offices and in 1814 was made prefect of police. On the abdication of Napoleon he paid his court to Louis XVIII., and was nominated a minister of state. The revolution of July, 1830, and the loss of his wealth affected him so much that he lost his reason, and died in a lunatic asylum in 1834. His *Mémoires sur Napoléon, le Directoire, le Consulat, l'Empire et la Restauration* are valuable.

**Boussa** (bös'a), or BUSSANG, a city of Africa, in the Soudan, on the Niger, near where are rapids; about lat. 10° 40' N. It was here that Mungo Park met his death in 1805. Pop. estimated at 12,000 to 18,000.

**Boussingault** (bö-saŋ-gō), JEAN BAPTISTE JOSEPH DIEUDONNÉ, French chemist, born at Paris in 1802, died 1887. He went to S. America in the employment of a mining company, and made extensive travels and valuable scientific researches there. Returning to France he became professor of chemistry at Lyons in 1839, was made a member of the Institute, and then made Paris his chief residence. His works deal chiefly with agricultural chemistry, and include *Économie Rurale* (translated into English and German); *Mémoires de Chimie agricole et de Physiologie*; *Agronomie, Chimie agricole, et Physiologie*, &c.

**Boustrophe'don**, a kind of writing which

is found on Greek inscriptions of the remotest antiquity. The lines do not commence uniformly at one side, but run on alternately from left to right and from right to left. It is called *boustrophēdon* (turning like oxen), because in this way oxen ploughed a field.

**Bouterwek** (bö'ter-vek), FRIEDRICH, German writer on philosophical and literary subjects, was born in 1766. After applying himself to many departments of learning, jurisprudence, poetry, &c., he at last became entirely devoted to philosophy and literary history. His best title to remembrance is his *History of Modern Poetry and Eloquence*, published 1801-19, which contains the fruit of wide studies and matured judgment. In particular the part which treats of Spanish poetry and eloquence has been highly valued, and has been translated into Spanish, English, and French.

**Bouts Rimés** (bö-rē-mā; French, 'rhymed ends'), words or syllables given as the ends of the verses, the other parts of the lines to be supplied by the ingenuity of the poet. In the 17th century the composition of *bouts rimés* was a fashionable amusement.

**Bov'idæ**, the ox family of animals, including the common ox, the bison, buffalo, yak, zebu, &c. They are hollow-horned ruminant animals, generally of large size, with broad, hairless muzzles and stout limbs, and most of them have been domesticated.

**Bovino**, a fortified town of South Italy, province of Foggia or Capitanata, 20 miles s.s.w. Foggia; the seat of a bishopric, suffragan to Benevento. Pop. 7900.

**Bow**, the name of one of the most ancient and universal weapons of offence. It is made of steel, wood, horn, or other elastic substance. The figure of the bow is nearly the same in all countries. The ancient Grecian bow was somewhat in the form of the letter Σ: in drawing it, the hand was brought back to the right breast, and not to the ear. The Scythian bow was nearly semicircular. The long-bow was the favourite national weapon in England. The battles of Crecy (1346), Poitiers (1356), and Agincourt (1415) were won by this weapon. It was made of yew, ash, &c., of the height of the archer, or about 6 feet long, the arrow being usually half the length of the bow. The arbalest, or cross-bow, was a popular weapon with the Italians, and was introduced into England in the 13th century, but never was so popular as the long-bow. In England the strictest regulations were made to encourage and facilitate the use of



## BOW — BOW INSTRUMENTS.

the bow. Merchants were obliged to import a certain proportion of bow-staves with every cargo; town-councils had to provide public shooting butts near the town. Of the power of the bow, and the distance to which it will carry, some remarkable anecdotes are related. Thus Stuart (*Athenian Antiquities* i.) mentions a random shot of a Turk, which he found to be 584 yards. In the journal of King Edward VI. it is mentioned that 100 archers of the king's guard shot at a 1-inch board, and that some of the arrows passed through this and into another board behind it, although the wood was extremely solid and firm. See *Archery*.

**Bow**, in music, is the name of that well-known implement by means of which the tone is produced from violins, and other instruments of that kind. It is made of a thin staff of elastic wood, tapering slightly till it reaches the lower end, to which the hairs (about 80 or 100 horse-hairs) are fastened, and with which the bow is strung. At the upper end is an ornamental piece of wood or ivory called the *nut*, and fastened with a screw, which serves to regulate the tension of the hairs.

**Bow Bells**, the peal of bells belonging to the church of St. Mary-le-Bow, Cheapside, London, and celebrated for centuries. One who is born 'within the sound of Bow Bells' is considered a genuine Cockney.

**Bowdich** (bou'dich), THOMAS EDWARD, African traveller, born in 1790. In 1816 he led an embassy to the King of Ashantee, and afterwards published an account of his mission (1819). Having undertaken a second African expedition, he arrived in the river Gambia, where disease put an end to his life, 1824.

**Bowdoin** (bō'dn), JAMES, an American worthy, born 1727, at Boston, New England; died 1790. He distinguished himself as an opponent of the unfortunate policy of Britain; in 1785 was appointed governor of Massachusetts, and he was a member of the convention assembled to deliberate on the adoption of the constitution of the United States. He was a friend and correspondent of Franklin.—*Bowdoin College*, Brunswick, Maine, was named after him. It is a flourishing institution, which has had among its students Longfellow and Hawthorne.

**Bower** (bou'ër), an anchor: so named from being carried at the *bow* of a ship. See *Anchor*.

**Bower**, ARCHIBALD, a Scottish writer,

born in 1686, of Catholic parents. He was employed by the booksellers in conducting the *Historia Literaria*, a monthly review of books, and in writing a part of the *Universal History*, in sixty vols. 8vo. He also published a *History of the Popes*, characterized by the utmost zeal against Popery. He died a Protestant in 1766.

**Bower-bird**, a name given to certain Australian birds of the starling family from a remarkable habit they have of building bowers to serve as places of resort. The bowers are constructed on the ground, and usually under overhanging branches in the most retired



Bower-bird (*Chlamydera maculata*) and its Run.

parts of the forest. They are decorated with variegated feathers, shells, small pebbles, bones, &c. At each end there is an entrance left open. These bowers do not serve as nests at all, but seem to be places of amusement and resort, especially during the breeding season.—*The Satin Bower-bird* (*Ptilonorhynchus holosericeus*), is so called from its beautiful glossy plumage, which is of a black colour. Another common species is the *Spotted Bower-bird* (*Chlamydera maculata*), which is about 11 inches long, or rather smaller than the first-mentioned, and less gay in colour, but is the most lavish of all in decorating its bowers.

**Bowie-knife**, a long kind of knife like a dagger, but with only one edge, named after Colonel James Bowie, and used in America by hunters and others.

**Bow Instruments** are all the instruments strung with cat-gut from which the tones are produced by means of the bow. The most usual are the double-bass (*violono* or *contrabasso*), the small bass, or *violoncello*, the tenor (*viola di braccio*), and the violin proper (*violino*). In reference to their construction the several parts are alike; the difference is in the size. See *Violin*.

**Bowles** (bōlz), WILLIAM LISLE, an English poet, was born in 1762 at King's Sutton, Northamptonshire, where his father was vicar; died in 1850. He was educated at Winchester and Oxford, where he gained high honours. In 1789 he composed a series of sonnets, by which the young minds of Coleridge and Wordsworth, then seeking for new and more natural chords in poetry, were powerfully affected. Having entered holy orders Bowles was, in 1805, presented to the living of Bremhill, in Wiltshire, where he continued to reside for the rest of his life. Besides the sonnets he published several poems (The Spirit of Discovery, The Missionary of the Andes, St. John in Patmos, &c.), which are characterized by graceful diction and tender sentiment rather than by any higher qualities.

**Bowline** (bō'-), in ships, a rope leading forward, which is fastened by bridles to loops in the ropes on the perpendicular edge of the square sails.

**Bowling Green**, capital of Warren Co., Ky.; trade pork and tobacco; manuf. iron and woollens; 3 banks. Pop. 1890, 7803.

**Bowls**, BOWLING, an ancient British game, still extremely popular. It is played on a smooth, level piece of green sward, generally about 40 yards long, and surrounded by a trench or ditch about 6 inches in depth. A small white ball called the *jack* is placed at one end of the green, and the object of the players, who range themselves in sides at the other, is so to roll their bowls that they may lie as near as possible to the jack. Each bowl is *biased* by being made slightly conical so as to take a curvilinear direction; and in making the proper allowance for this bias, and so regulating the cast of the ball, consist the skill and attraction of the game. The side which owns the greatest number of bowls next the jack, each bowl so placed constituting a point, carries off the victory.

**Bowman**, SIR WILLIAM, English anatomist and surgeon, born in 1816. He has been surgeon to King's College Hospital, London, and Professor of Physiology and Anatomy in King's College, and is especially distinguished as an ophthalmic surgeon. He gained the Royal Society's royal medal for physiology in 1842. He was collaborator with Todd in the great work on the Physiological Anatomy and Physiology of Man, and has written on ophthalmology. He was created a baronet in 1884.

**Bowring** (bou'ring), SIR JOHN, an English statesman and linguist, born at Exeter

1792, being the son of a cloth manufacturer. While still very young he was taken by his father into his own business, and employed by him to travel in different parts of Europe. Having an extraordinary linguistic faculty he made use of his residence in foreign countries to acquire the different languages, and his first publications consisted of translations of poems and songs from the Russian, Servian, Polish, Magyar, Swedish, Frisian, Esthonian, Spanish, and other languages. He is well known also by his translations from Goethe, Schiller, and Heine. He was an ardent Radical and supporter of Jeremy Bentham, and edited the Westminster Review from 1825 to 1830. He held various government appointments, one of them being the governorship of Hong-Kong, and the last being in 1861, when he was sent to Italy to report on British commercial relations with the new kingdom. He died Nov. 23, 1872.

**Bowsprit** (bō'-), the large boom or spar which projects over the stem of a vessel, having the foremast and foretop-mast stays and staysails attached to it, while extending beyond it is the jib-boom.

**Bowstring-hemp**, the fibre of the leaves of an East Indian plant, or the plant itself, *Sansevierazeylanica*, order Liliaceæ, so named from being made by the natives into bowstrings. The fibre is fine and silky, but very strong, and may become a valuable article in European manufacture.

**Bow-window**, a window constructed so as to project from a wall, properly one that forms a segment of a circle. See *Bay-window*.

**Bowyer** (bō'yér), WILLIAM, an English printer and classical scholar, born 1699, a native of London, where his father, also a printer, carried on business. In 1729 he became printer of the votes of the House of Commons, and subsequently printer to the Society of Antiquarians and to the Royal Society. In 1767 he was nominated printer of the journals of the House of Lords and the rolls of the House of Commons. He died in 1777.

**Box**. See *Box-tree*.

**Box-elder**, the ash-leaved maple (*Negundo aceroides*), a small but beautiful tree of the U. States, from which sugar is sometimes made.

**Boxing**, or PUGILISM, a manner of fighting with the fists so common in England as to be regarded abroad as a national accomplishment. The art of boxing consists in

showing skill in dealing blows with the fist against one's opponent, especially on the upper part of the body, while at the same time one protects one's self. In England professional boxers, who made a livelihood out of their skill in the art, were at one time common, especially during the reigns of the Georges, when persons of the highest rank were sometimes to be seen at pugilistic combats, and 'professors' of the art frequently had members of the nobility among their pupils. Byron relates in his diary that he received instruction in boxing from the celebrated Jackson, who made a fortune as a pugilist. Boxing has, however, now fallen in a great measure into disrepute, and prize-fights are illegal in England, and both the principals and the spectators may be proceeded against. At the gladiatorial shows of the Greeks and Romans boxing was common, but in a more dangerous form, the fist being armed with leather appliances loaded with iron or lead.

**Boxing-day**, the day after Christmas, which has long been held as a holiday in England. It is so called from the practice of giving Christmas *boxes* as presents on that day.

**Boxing the Compass**, in seaman's phrase, the repetition of all the points of the compass in their proper order—an accomplishment required to be attained by all sailors.

**Box-tortoise**, a name given to one or two North American tortoises, genus *Cistudo*, that can completely shut themselves into their shell.

**Box-tree** (*Buxus sempervirens*), a shrubby evergreen tree, 12 or 15 feet high, order Euphorbiaceæ, a native of England, Southern Europe, and parts of Asia, with small oval and opposite leaves, and greenish, inconspicuous flowers, male and female on the same tree. It was formerly so common in England as to have given its name to several places—Boxhill, in Surrey, for instance, and Boxley, in Kent. The wood is of a yellowish colour, close-grained, very hard and heavy, and admits of a beautiful polish. On these accounts it is much used by turners, wood-carvers, engravers on wood (no wood surpassing it in this respect), and mathematical-instrument makers. Flutes and other wind-instruments are formed of it. The box of commerce comes mostly from the regions adjoining the Black Sea and Caspian, and is said to be diminishing in quantity. In gardens and shrubberies box-trees may often be seen clipped into

various formal shapes. There is also a dwarf variety reared as an edging for garden walks and the like.

**Boyaca'**, in South America, one of the departments or provinces of Colombia. On the west side the country is traversed by a chain of the Andes, from which it slopes towards the east into immense plains or *llanos*, mostly uncultivated, and watered by the tributaries of the Orinoco. Area, 33,351 sq. miles. Pop. 702,000.

**Boy'ars**. See *Boiars*.

**Boy-bishop**, formerly in England a boy chosen by cathedral choirs or pupils in grammar-schools as a mock-bishop to take leading parts in certain mummeries or festivities in the month of December annually.

**Boyce**, WILLIAM, English musical composer, born 1710, a native of London, and a pupil of Dr. Maurice Greene, organist of St. Paul's. He was latterly organist to the Chapel Royal, and wrote many pieces for the theatre and other places of entertainment, but his principal compositions are church services. One of his anthems, 'Blessed is he that considereth the poor,' is sung every year at the festival given for the sons of the clergy. He died in 1779. He published a splendid collection of church music in three vols. folio.

**Boy'cotting**, a name given to an organized system of social and commercial ostracism employed in Ireland in connection with the Land League and the land agitation of 1880 and 1881 and subsequently. Landlords, tenants, or other persons who are subjected to boycotting find it difficult or impossible to get any one to work for them, to supply them with the necessaries of life, or to associate with them in any way. It took its name from Captain James *Boycott*, a Mayo landlord, against whom it was first put in force.

**Boyd**, ZACHARY, an eminent Scottish divine of the 17th century, born before the year 1590 in Ayrshire. After studying at Glasgow University he went to the College of Saumur, in France, and in 1611 he was made a regent in this university. In consequence of the persecution of the Protestants he was obliged in 1621 to return to his native country, and two years later was appointed minister of the Barony parish, Glasgow, and was thrice elected rector of the university there. He wrote many works, amongst which the principal is the *Last Battell of the Soule in Death*. His *Zion's Flowers*, a collection of metrical translations of Scrip-

ture history, often called Zachary Boyd's Bible, was bequeathed along with many other manuscripts and a large sum of money to the University of Glasgow. It is a quaint specimen of the devotional culture of the time. He died in 1653 or 1654.

**Boydell**, JOHN, an English engraver, but chiefly distinguished as an encourager of the fine arts. With the profits of a volume of engravings executed by himself, and published in 1746, he set up as a printseller, and soon established a high reputation as a liberal patron of good artists, with the result that for the first time English prints began to be exported to the Continent. He engaged Reynolds, Opie, West, and other celebrated painters to illustrate Shakespeare's works, and from their pictures was produced a magnificent volume of plates, the Shakespeare Gallery (London, Boydell, 1803). In 1790 Boydell had been made lord-mayor; but the outbreak of war consequent on the French revolution injured his foreign trade and brought him into difficulties. He died in 1804.

**Boyer** (bwä-yā), ALEXIS, French surgeon, born 1757, died 1833. He had a brilliant career as a student, and was appointed first surgeon to Napoleon, receiving at the same time the title of Baron of the Empire. His chief works are *Traité d'Anatomie* (Paris, 1797-99); *Traité des Maladies Chirurgicales et des Opérations qui leur conviennent* (eleven vols., 1814-26).

**Boyer** (bwä-yā), JEAN PIERRE, president of the Republic of Hayti, born in 1776 at Port-au-Prince, died at Paris 1850. He was a mulatto by birth, but was educated in France. In 1792 he entered the French army, and fought with distinction against the English in San Domingo. It was largely by his efforts that in 1821 all parts of Hayti were brought under one republican government, of which he was chosen president. His administration in its earlier years was wise and energetic; but latterly financial difficulties and other causes made the Haytians dissatisfied with his rule, and a revolt drove him into exile in 1843.

**Boyle**, a town of Ireland, county Roscommon, with a large trade in corn and butter. Boyle Abbey, now in ruins, dates from the 12th century. Pop. 2994.

**Boyle**, CHARLES, Earl of Orrery, born 1676, died 1731, was nominally the editor of the edition of the Epistles of Phalaris which led to a famous controversy with Bentley (see *Bentley*), and to Swift's *Battle of the*

Books. He served in the army and as a diplomatist, and wrote a comedy and some worthless verse. The astronomical apparatus called the orrery took its name from him.

**Boyle**, RICHARD, Earl of Cork, English statesman, was born in 1566. In 1588 he went to Dublin with little or no money, but with good recommendations, and by prudence and ability he managed to acquire considerable estates. As clerk of the Council of Munster he distinguished himself by his talents and activity, and became successively a knight and privy-councillor, Baron Boyle of Youghal, and finally, in 1620, Viscount Dungarvan and Earl of Cork. He was an able and energetic ruler, introducing many useful arts and manufactures amongst the people. Disaffection and rebellion he put down with a strong and vigorous hand. He died in 1643.

**Boyle**, ROBERT, a celebrated natural philosopher, was born at Lismore, Ireland, 1626, and was the seventh son of Richard the first earl of Cork. After finishing his studies at Eton he travelled for some years on the Continent till, in 1644, he settled in the manor of Stalbridge, Dorsetshire, which his father had left him. Here he devoted himself to scientific studies, to chemistry and natural philosophy in particular. He was one of the first members of the society founded in 1645, afterwards known as the Royal Society. At Oxford, to which he had gone in 1652, he occupied himself in making improvements on the air-pump, by means of which he demonstrated the elasticity of air. Although his scientific work shows an accurate, minute, and methodical intellect, in religious matters he was subject to melancholy and fanciful terrors. With the view of settling his faith he began the study of those oriental languages which contain the origins of Christianity, and formed connections with such eminent scholars as Pococke, Clarke, Barlow, &c. He also instituted public lectures, known as the Boyle Lectures, 'for proving the Christian religion against Atheists, Deists, Pagans, Jews, and Mohammedans, not descending to any controversies amongst Christians themselves.' The first series was delivered by Richard Bentley. Samuel Clarke, Whiston, and F. D. Maurice have been amongst succeeding Boyle lecturers. Boyle died in 1691, and was interred in Westminster Abbey.

**Boyle**, ROGER, Earl of Orrery, brother of Robert Boyle, born in 1621, died 1679. In

Ireland he zealously supported the cause of Charles I., but after the death of the king he retired for a time from public life. At length he accepted a commission from Cromwell, whom he served with zeal and fidelity, and by whom he was highly esteemed. On the death of Cromwell he exerted himself with such dexterity to bring about the royal restoration that Charles II. rewarded him with the title of Earl of Orrery.

**Boyle Lectures.** See *Boyle, Robert*.

**Boyle's Law**, otherwise called *Mariotte's Law*, a law in physics to the effect that the volume of a gas will vary inversely to the pressure to which it is subjected.

**Boyne**, a river of Ireland, which rises in the Bog of Allen, and after a course of 60 miles falls into the Irish Sea 4 miles from Drogheda. On its banks was fought the battle between the adherents of James II. and William III. in 1690, in which the latter proved victorious, James being obliged to flee to the Continent. The anniversary of this victory (12th July) is still joyfully celebrated by Irish Protestants, and the playing of the 'Orange' tune 'Boyne Water' is but too apt to excite the ire of Irish Roman Catholics.

**Bozrah**, an ancient city of Palestine, east of the Jordan, and about 80 miles south of Damascus. It was the capital of Og, king of Bashan, and subsequently belonged to the tribe of Manasseh. Early in the Christian era it became a flourishing place, and was long a great emporium of trade. It is now a scene of ruins.

**Bozzaris** (bot-sä'ris), MARKO, a hero of the Greek war of independence against the Turks, born about the end of last century. After the fall of Suli he retired to the Ionian Islands, from whence he made a vain attempt to deliver his native country. In 1820, when the Turks were trying to reduce their overgrown vassal, Ali Pasha of Janina, to submission, the latter sought aid from the exiled Suliotes, and Marko Bozzaris returned to Epirus. On the outbreak of the war of independence he at once joined the Greek cause, and distinguished himself as much by his patriotism and disinterestedness as by his military skill and personal bravery. In the summer of 1823, when he held the command-in-chief of the Greek forces at Missolonghi, he made a daring night attack on the camp of the Pasha of Scutări, near Karpenisi. The attack was successful; but the triumph of the Greeks was clouded by the fall of the heroic Boz-

zaris. His deeds are celebrated in the popular songs of Greece.

**Bra**, a town in North Italy, province of Cuneo, with a trade in cattle, grain, wine, and silk. Pop. 9125.

**Brabançonne** (brä-bän-son'), the national song of the Belgians, written during the revolution of 1830 by Jenneval an actor at the theatre of Brussels, and set to music by Campenhout.

**Brabant'**, the central district of the lowlands of Holland and Belgium, extending from the Waal to the sources of the Dyle, and from the Meuse and Limburg plains to the lower Scheldt. It is divided between the kingdoms of Holland and Belgium, into three provinces: 1st, Dutch or North Brabant, area 1977 sq. m., pop. (1891), 516,670; 2d, Belgian province of Antwerp, area of 1095 sq. m., pop. 713,740; and 3d, the Belgian province of South Brabant, area 1276 sq. m., pop. 1,120,976. The country is generally a plain, gently sloping to the N.W., and is mostly fertile and well cultivated; agriculture and the rearing of cattle being the principal employment of the inhabitants. In the north the inhabitants are Dutch; in the middle district, Flemings; in the south Walloons. Southward of Brussels the language is French; northward, Dutch and Flemish. In the 5th century Brabant came into possession of the Franks, and after being alternately included in and separated from Lorraine it emerges at length in 1190 as a duchy under a Duke of Brabant. It eventually came by marriage into possession of the dukes of Burgundy, and passed with the last representative of that line, Mary of Burgundy, to the house of Austria, and finally to Philip II. of Spain. In the famous revolt of the Netherlands, caused by the cruelties of King Philip and his agent, the Duke of Alva, North Brabant succeeded in asserting its independence, and in 1648 it was incorporated with the United Provinces. South Brabant remained, however, in possession of the Spaniards, and at the peace of Utrecht in 1714 passed again, along with the other southern provinces of the Netherlands, to the imperial house of Austria. See *Belgium*.

**Bracelet**, a kind of ornament usually worn on the wrist, the use of which extends from the most ancient times down to the present, and belongs to all countries, civilized as well as uncivilized. Bracelets were in use in Egypt and amongst the Medes and Persians at a very remote period, and in the

**Bible** the bracelet is frequently mentioned as an ornament in use among the Jews, both men and women. Among the ancient Greeks bracelets seem to have been worn only by the women. The spiral form was preferred, and very often made to assume the appearance of snakes, which went round the arm twice or thrice. Among the Romans it was a frequent practice for a general to bestow bracelets on soldiers who had distinguished themselves by their valour. Roman ladies of high rank frequently wore them both on the wrist and on the upper arm. Among the ancient heathen Germanic tribes they formed the chief and almost only ornament, as is shown by their being so often found in old graves. They seem to have been used by the men even more than by the women, and were the gifts by which an ancient German chief attached his followers to himself. So, in old Anglo-Saxon poems, 'ring-giver' is a common name for the lord or ruler.

**Braces**, in ships, ropes passing through blocks at the ends of the yards, used for swinging the latter round so as to meet the wind in any desired direction.

**Brachiopoda** (bra-ki-op'o-da), the name given to a class of Mollusca, so named from the development of a long spirally-coiled, fringed appendage or arm on either side of the mouth (Gr. *brachiōn*, an arm, and *pous*, *podos*, a foot), serving as respiratory organs. They are bivalves, and in this respect they resemble the Lamellibranchiata. They have no proper power of locomotion, and remain fixed to submarine bodies, in some cases by a peduncle passing through an aperture at the 'beak.' They are widely diffused, and in the fossil state are interesting to the geologist by enabling him to identify certain strata. The chief genera are *Lingula*, *Terebatula*, and *Rhynchonella*.

**Brachycephalic** (bra-ki se-fal'ik; Gr. *brachys*, short, *kephalē*, the head), a term applied in ethnology to heads whose diameter from side to side is not much less than from front to back, as in the Mongolian type: opposed to *dolichocephalic*.

**Brachypteræ** (bra-kip'te-rē; 'short-winged'), a name given to a family of web-footed birds, penguins, auks, divers, guillemots, &c., in which the wings are short and the legs placed far back in the body. They are all strong divers and swimmers.

**Brachyura** (bra-ki-ö'ra; 'short-tailed'), a section of the ten-footed crustaceans or crabs (Decapoda), having a very short jointed

tail folded closely under the thorax as in the common crab.

**Bracken**, **BRAKE**, *Pteris aquilina*, a species of fern very common in America and Europe generally, and often covering large areas on hillsides and waste grounds. It has a black creeping rhizome, with branched pinnate fronds growing to the height often of several feet, and it forms an excellent covert for game. The rhizome is bitter, but has been eaten in times of famine. The plant is astringent and anthelmintic; when burned it yields a good deal of alkali. The rhizome of *Pteris esculenta*, a native of New Zealand, was formerly a staple article of food among the Maories.

**Bracket**, a short piece or combination of pieces, generally more or less triangular in

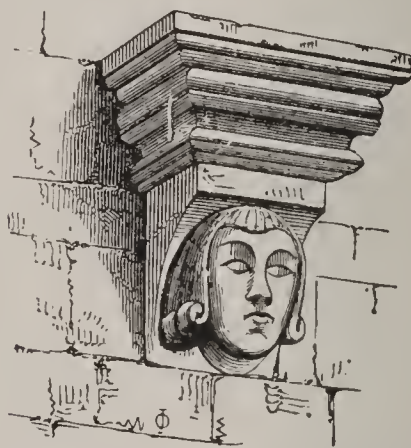

Bracket, Harlestone Church, Northamptonshire.

outline, and projecting from a wall or other surface. They may be either of an ornamental order, as when designed to support a statue, a bust, or such like, or plain forms of carpentry, such as support shelves, &c. Brackets may also be used in connection with machinery, being attached to walls, beams, &c., to support a line of shafting.

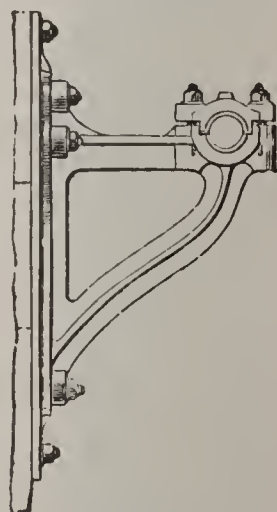

Wall-bracket.

**Bract**, a leaf, from the axil of which a flower or flower-stalk proceeds, and thus distinguished from the ordinary leaf, from the axil of which the leaf-bud proceeds. It differs from other leaves in shape or colour, and is generally situated on the peduncle near the flower. It is sometimes called also the floral leaf.

**Brac'teates** (-āts), old thin coins of gold or silver, with irregular figures on them, stamped upon one surface only, so that the impression appears raised on one side while the other appears hollow.—*Bracteated* coins, coins of iron, copper, or brass, covered over with a thin plate of some richer metal such as gold or silver.

**Bracton**, HENRY DE, one of the earliest writers on English law, flourished in the thirteenth century. He studied law at Oxford, became a judge, and afterwards chief-justice of England.

**Braddock**, Allegheny Co., Pa., a manufacturing town; steel rails and cars. Pop. 1891, 8561. Scene of Braddock's defeat.

**Braddock**, EDWARD, major-general and commander of the British army in the expedition against the French on the river Ohio, in 1755. In the spring of that year he set out from Virginia to invest Fort Duquesne, now Pittsburg, but from want of caution fell into an Indian ambush by which he lost nearly one-half of his troops and received himself a mortal wound.

**Braddon**, MARY ELIZABETH, a well-known novelist, born in London in 1837, and daughter of a solicitor there. After publishing some poems and tales, in 1862 she brought out *Lady Audley's Secret*, the first of a series of clever sensational novels. She conducts the London magazine *Belgravia*.

**Brad'ford**, a municipal and parl. borough and important manufacturing town in W. Riding of Yorkshire, England. The more modern portion has well-built streets, and since 1861 most extensive street improvements have been carried out at a cost of about £1,000,000. There is a large number of scientific, educational, and charitable institutions, amongst which may be mentioned the new technical college, the free grammar-school endowed by Charles II., the fever hospital, built at a great cost, and the almshouses of the Tradesmen's Benevolent Society. There are several public parks, and an extensive system of water-works which afford a supply of about 10 million gallons a day. Bradford is the chief seat in England of the spinning and weaving of worsted yarn and woollens. Pop. 1891, 216,361.

**Bradford**, capital of McKean county, Pa., centre of an extensive oil district, has 7 factories, banks, opera house, library, 3 papers. Pop. in 1890, 10,514.

**Bradford-on-Avon**, or Great Bradford, an ancient town of England, in Wiltshire, beautifully situated 28 miles N.W. of Salis-

bury, on the banks of the Lower Avon, with manufactures of woollen cloth.

**Bradlaugh** (brad'la), CHARLES, English secularist, atheist, and advocate of republicanism, born in London in 1833. He is well known by his writings and lectures, and more especially by his efforts to gain admission to parliament. Being elected for Northampton in 1880 he claimed the right to make affirmation simply instead of taking the oath which members of parliament take before they can sit and vote, but being a professed atheist this right was denied him. Though he was repeatedly re-elected by the same constituency, the majority of the House of Commons continued to declare him disqualified for taking the oath or affirming; and it was only after the election of a new parliament in 1885 that he was allowed to take his seat without opposition as a representative of Northampton. He was editor of the *National Reformer*. Died in 1891.

**Brad'ley**, JAMES, English astronomer, born at Sherborne in 1692. He studied theology at Oxford, and took orders; but devoting himself to astronomy he was appointed, in 1721, professor of that science at Oxford. Six years afterwards he made known his discovery of the aberration of light, and his researches for many years were chiefly directed towards finding out methods for determining precisely that aberration. It is largely owing to Bradley's discoveries that astronomers have since been able to make up astronomical tables with the necessary accuracy. In 1741 Bradley was made astronomer-royal, and removed to Greenwich. He died in 1762. His *Astronomical Observations* were published at Oxford, 1805.

**Bradshaw**, JOHN, president of the High Court of Justice which tried and condemned Charles I. He studied law at Gray's Inn and attained a fair practice. When the king's trial was determined upon, Bradshaw was appointed president of the court; and his stern and unbending deportment at the trial did not disappoint expectation. Afterwards he opposed Cromwell and the Protectorate, and was in consequence deprived of the chief-justiceship of Chester. On the death of Cromwell he became lord-president of the council, and died in 1659. At the Restoration his body was exhumed and hung on a gibbet with those of Cromwell and Ireton.

**Bradshaw's Railway Guide**, a well-known English manual for travellers, first issued by a George Bradshaw, a printer and engraver

of Manchester in 1839. It is now published on the 1st of each month, and contains the latest arrangements of railway and steam-boat companies, besides other useful information. There are now many such hand-books in the field, and the idea has since been further developed in the descriptive hand-books of Murray, Bædeker, and others.

**Bradwar'dine**, THOMAS, 'Doctor Profundus,' Archbishop of Canterbury, born about 1290, died 1349. He was distinguished for his varied learning, and more particularly for his treatise *De Causa Dei contra Pelagium*, an extensive work against the Pelagian heresy, for centuries a standard authority. He was chaplain and confessor to Edward III., whom he accompanied to France, being present at Cressy and the capture of Calais. Being appointed archbishop he hastened to England, but died of the black death on reaching London.

**Bra'dy**, NICOLAS, born in 1659 at Bandon, in Ireland. He was rector of the church of St. Catherine Cree, London, and latterly of Richmond, Surrey. He made a translation of the *Æneid*; but is only remembered now as the collaborateur of Nahum Tate in that version of the Psalms commonly used in the Episcopal church. He died in 1726.

**Brad'ypus**. See *Sloth*.

**Braemar'**, a Highland district in the s.w. corner of Aberdeenshire. It contains part of the Grampian range with the heights of Ben Macdhui, Cairntoul, Lochnagar, &c. The district has some fine scenery, valleys and hillsides covered with birch and fir, but consists mostly of uncultivated heaths. The Queen's residence Balmoral is here, on the banks of the Dee.

**Braga**, an ancient town in Northern Portugal, the seat of an archbishop who is primate of Portugal, charmingly situated on a rising ground and surrounded by walls flanked with towers, and with suburbs outside. It contains an archiepiscopal palace, and a richly ornamented Gothic cathedral of the 13th century, and is a place of considerable trade and manufactures. There still exist remains of a Roman temple, amphitheatre, and aqueduct. Pop. 20,258.

**Bragan'za**, or BRAGAN'ÇA, a town of Portugal, capital of the former province Trasmontes, with a castle, the ancient seat of the dukes of Braganza, from whom the present reigning family of Portugal are descended. Pop. 5500.

**Braham** (brā'am), JOHN, a celebrated

tenor singer, of Jewish extraction, was born in London in 1774. He appeared with the greatest success on the leading stages of France, Italy, and the United States, as well as in his own country. He excelled mainly in national songs, such as *The Bay of Biscay*, *O*, and *The Death of Nelson*, and continued to attract large audiences even when eighty years old. He died in 1856.

**Brahe** (brä'ā), TYCHO, Danish astronomer, born in 1546 of a noble family, died 1601. He studied law at Copenhagen and Leipzig, but from 1565 gave himself up to astronomy, and in 1580 built an observatory on the island of Hveen in the Sound, providing it with the best instruments then procurable. Here he excogitated the planetary system associated with his name, the earth, by his theory, being regarded as the centre of the heavenly bodies. After the death of his patron, Frederick II. of Denmark, he left his native country in 1597 and went to Germany. Here he was patronized by the Emperor Rudolph, who gave him a yearly allowance and a residence at Prague, where he died. His astronomical works were all written in Latin. He is chiefly remarkable for his services to practical astronomy, his observations being superior in accuracy to those of his predecessors.

**Brahilow**. See *Braïla*.

**Brah'ma**, a Sanskrit word signifying (in its neuter form) the Universal Power or



Brahma.—Bronze, Indian Museum.

ground of all existence, and also (in its masculine form with long final syllable) a particular god, the first person in the Triad



## BRAHMANISM.

(Brahmā, Vishnu, and Siva) of the Hindus. The personal god Brahmā is represented as a red or golden-coloured figure with four heads and as many arms, and he is often accompanied by the swan or goose. He is the god of the fates, master of life and death, yet he is himself created, and is merely the agent of Brahmā, the Universal Power. His moral character is no better than that of the Grecian Zeus.

**Brah'manism**, a religious and social system prevalent amongst the Hindus, and so called because developed and expounded by the sacerdotal caste known as the Brahmans (from *brahman*, a potent prayer; from root *brih* or *vrih*, to increase). It is founded on the ancient religious writings known as the Vedas and regarded as sacred revelations, of which the Brahmans as a body became custodians and interpreters, being also the officiating priests and the general directors of sacrifices and religious rites. As the priestly caste increased in numbers and power they went on elaborating the ceremonies, and added to the Vedas other writings tending to confirm the excessive pretensions of this now predominant caste, and give them the sanction of a revelation. The earliest supplements to the Vedas are the *Brahmanas*, more fully explaining the functions of the officiating priests. Both together form the revealed Scriptures of the Hindus. In time the caste of Brahmans came to be accepted as a divine institution, and an elaborate system of rules defining and enforcing by the severest penalties its place as well as that of the inferior castes was promulgated. Other early castes were the *Kshatriyas* or warriors, and the *Vaisyas* or cultivators, and it was not without a struggle that the former recognized the superiority of the Brahmans. It was by the Brahmans that the Sanskrit literature was developed; and they were not only the priests, theologians, and philosophers, but also the poets, men of science, lawgivers, administrators, and statesmen of the Aryans of India.

The sanctity and inviolability of a Brahman are maintained by severe penalties. The murder of one of the order, robbing him, &c., are inexpiable sins; even the killing of his cow can only be expiated by a painful penance. A Brahman should pass through four states: First, as *Brahmachari*, or novice, he begins the study of the sacred Vedas, and is initiated into the privileges and the duties of his caste. He has a right to alms, to exemption from taxes, and from capital and

even corporal punishment. Flesh and eggs he is not allowed to eat. Leather, skins of animals, and most animals themselves are impure and not to be touched by him. When manhood comes he ought to marry, and as *Grihastha* enter the second state, which requires more numerous and minute observances. When he has begotten a son and trained him up for the holy calling he ought to enter the third state, and as *Vanaprastha*, or inhabitant of the forest, retire from the world for solitary praying and meditation, with severe penances to purify the spirit; but this and the fourth or last state of a *Sannyasi*, requiring a cruel degree of asceticism, are now seldom reached, and the whole scheme is to be regarded as representing rather the Brahmanical ideal of life than the actual facts.

The worship represented in the oldest Vedic literature is that of natural objects: the sky, personified in the god *Indra*; the dawn, in *Ushas*; the various attributes of the sun, in *Vishnu*, *Surya*, *Agni*, &c. These gods were invoked for assistance in the common affairs of life, and were propitiated by offerings which, at first few and simple, afterwards became more complicated and included animal sacrifices. In the later Vedic hymns a philosophical conception of religion and the problems of being and creation appears struggling into existence; and this tendency is systematically developed by the supplements and commentaries known as the *Brahmanas* and the *Upanishads*. In some of the *Upanishads* the deities of the old Vedic creed are treated as symbolical. *Brahma*, the supreme soul, is the only reality, the world is regarded as an emanation from him, and the highest good of the soul is to become united with the divine. The necessity for the purification of the soul in order to its reunion with the divine nature gave rise to the doctrine of *metempsychosis* or *transmigration*.

This philosophical development of Brahmanism gave rise to a distinct separation between the educated and the vulgar creeds. Whilst from the fifth to the first century B.C. the higher thinkers amongst the Brahmans were developing a philosophy which recognized that there was but one god, the popular creed had concentrated its ideas of worship round three great deities—*Brahmā*, *Vishnu*, and *Siva*, who now took the place of the confused old Vedic Pantheon. *Brahmā*, the creator, though considered the most exalted of the three, was too abstract an idea

to become a popular god, and soon sank almost out of notice. Thus the Brahmans became divided between Vishnu, the preserver, and Siva, the destroyer and reproducer, and the worshippers of these two deities now form the two great religious sects of India. Siva, in his philosophical significance, is the deity mostly worshipped by the conventional Brahman, while in his aspect of the Destroyer, or in one of his female manifestations, he is the god of the low castes, and often worshipped with degrading rites. But the highly cultivated Brahman is still a pure theist, and the educated Hindu in general professes to regard the special deity he chooses for worship as merely a form under which the One First Cause may be approached.

The sharp division of the people of India into civilized Aryans and rude non-Aryans has had a great influence upon Brahmanism, and thus the spiritual conceptions of the old Vedic creed have been mixed in modern Hinduism with degrading superstitions and customs belonging to the so-called aboriginal races. Suttee, for example, or the burning of widows, has no authority in the Veda, but like most of the darker features of Hinduism is the result of a compromise which the Brahmanical teachers had to make with the barbarous conceptions of non-Aryan races in India. The Buddhist religion has also had an important influence on the Brahmanic.

The system of caste originally no doubt represented distinctions of race. The early classification of the people was that of 'twice-born' Aryans (priests, warriors, husbandmen) and once-born non-Aryans (serfs); but intermarriages, giving rise to a mixed progeny, and the variety of employments in modern times, have profoundly modified this simple classification. Innumerable minor distinctions have grown up, so that amongst the Brahmans alone there are several hundred castes who cannot intermarry or eat food cooked by each other.

The Brahmans represent the highest culture of India, and as the result of centuries of education and self-restraint have evolved a type of man distinctly superior to the castes around them. They have still great influence, and occupy the highest places at the courts of princes. Many, however, are driven by need or other motives into trades and employments inconsistent with the original character of their caste.

**Brahmapu'tra**, a large river of Asia,

whose sources, not yet explored, are situated near Lake Manasarovara, in Thibet, near those of the Indus. In Thibet, where it is called the Sanpoo, it flows eastwards north of the Himalayas, and, after taking a sharp bend and passing through these mountains, it emerges in the north-east of Assam as the Dihong; a little further on it is joined by the Dibong and the Lohit, when the united stream takes the name of Brahmaputra, literally the son of Brahma. After entering Bengal it joins the Ganges at Goalanda, and further on the Meghna, and their united waters flow into the Bay of Bengal. The Brahmaputra is navigable by steamers for about 800 miles from the sea, its total length being, perhaps, 1800.

**B ahmo-Somaj**, or the Theistic Church of India was founded in 1830 by an enlightened Brahman, who sought to purify his religion from impurities and idolatries. This church, while accepting what religious truth the Vedas may contain, rejects the idea of their special infallibility, and founds its faith on principles of reason. The members do not in principle recognize the distinction of caste, and have made great efforts to weaken this as well as other prejudices amongst their countrymen.

**Braïla**, a town in Roumania, formerly a fortress, on the left bank of the Danube, which divides itself here into a number of arms, one of them forming the harbour of the town. The export of grain and the sturgeon fisheries are amongst the principal industries in Braïla. Pop. 1890, 46,715.

**Braïls**, on ships, a name given to all the ropes employed to haul up the bottoms, lower corners, and skirts of the great sails in general.

**Brain**, the centre of the nervous system, and the seat of consciousness and volition in man and the higher animals. It is a soft substance, partly gray and partly whitish, situated in the skull, penetrated by numerous blood-vessels, and invested by three membranes or *meninges*. The outermost, called the *dura mater*, is dense and elastic. The next, the *tunica arachnoidea*, is very thin, and is really double. The third, the *pia mater*, covers the whole surface of the brain, and is full of blood-vessels. The brain consists of two principal parts, connected by bands of fibres. The one, called the *cerebrum*, occupies, in man, the upper part of the head, and is seven or eight times larger than the other, the *cerebellum*, lying behind and below it. The surface of

the brain exhibits the appearance of a series of ridges and furrows, forming what are called the *convolutions*. The cerebrum is divided into two portions, the right and left hemispheres, by the *longitudinal fissure*, the hemispheres being at the same time transversely connected by a band of nervous matter called the *corpus callosum*. The external or grayish substance of the brain is softer than the internal white substance. The cerebellum lies below the cerebrum, in a peculiar cavity of the skull. It is divided into a right and a left hemisphere, connected by a bridge of nervous matter called the *pons Varolii*, under which is the *medulla oblongata* or continuation of the spinal marrow. Like the cerebrum, it is gray on the outside and whitish within. At the base of the brain are several masses of nervous matter or ganglia known as the *corpora striata* (two), *optic thalami* (two), and *corpora quadrigemina* (four); and there are in it certain cavities or *ventricles*. Every part of



Brain and Spinal Cord.

the brain is exactly symmetrical with the part opposite. Twelve pairs of nerves proceed from the base of the brain, including the nerves for the organs of smell, of sight, of hearing, and of taste, also those for the muscles of the face, those for the cavity of the mouth and for the larynx. When compared with the brain of other animals, the human brain presents striking differences. Even the brain of the higher classes of the inferior vertebrate animals differs from that of man, especially in the degree of development; while among the lower grades there is sometimes, properly speaking, no brain at all, but only nerve ganglia, which correspond to the brain. In size, also, the brain of the lower animals, although sometimes (as in the elephant) actually greater, is always much less when compared with the size of the whole

body, and it is found that the size of the brain proportionally to the size of the body is a direct measure of the intelligence of different animals. In man the brain weighs from 2 to 4 lbs., the average weight in male European adults being 49 to 50 oz., or about  $\frac{1}{3}$ th of the weight of the body; in the dog the average weight is about  $\frac{1}{12}$ th of the animal; in the horse  $\frac{1}{48}$ th; and in the sheep  $\frac{1}{75}$ th. The heaviest brain yet known was that of Cuvier—64 $\frac{1}{2}$  oz. The brain of females weighs 5 oz. less on the average than that of males. The brain attains its highest degree of development earlier than any other part of the body. In old age it loses both in bulk and in weight. Comparatively little is known of the functions of the separate parts of the brain, but, speaking generally, the parts lying in front have functions connected with the intellectual part of man's nature; while the parts lying nearer the back of the head belong more to our merely animal or organic nature. As the central organ of the nervous system the brain is sympathetically affected in nearly all cases of acute disease. Diseases of the brain fall into two classes, according as they exhibit mental characteristics alone, or also anatomical disturbances. To the former class belong hypochondria, mania, &c. Amongst the latter may be mentioned meningitis, or inflammation of the membranes of the brain, which seldom occurs without affecting also the substance of the brain, and thus giving rise to phrenitis; hydrocephalus, or water in the head, caused by pressure of water in the cavities of the brain; softening of the brain, frequently the result of chronic inflammation; and plethora or poverty of blood in the brain, which, though opposite diseases, may cause the same symptoms of giddiness and headache.

**Brain-coral**, coral of the genus *Meandrina*, so called from their rounded shape and convolutions.

**Braine-le-comte** (brān-lè-kont), an ancient town in Belgium, province of Hainault, about 20 miles s.s.w. of Brussels, with a handsome church of the 13th century; and breweries, dye-works, oil and cotton mills, &c. Pop. 8176.

**Brainerd**, Crow Wing co., Minn., on Northern Pacific R. R., has railroad shops, &c. Pop. 1890, 5703.

**Brake**, a contrivance for retarding or arresting motion by means of friction. In machinery it generally consists of a simple or compound lever, that may be pressed

forcibly upon the periphery of a wheel, fixed upon a shaft or axis. A similar contrivance is attached to road and railway carriages, but continuous brakes applied to every pair of wheels in a railway train, and operated by air either by the *compression* or *vacuum* method, are now generally used on railways. By the first method, of which the Westinghouse brake is an example, the air is compressed by a pump on the locomotive and conveyed by pipes and tubes to cylinders which are under each car, and the pistons of which act on the brake-levers. In the *vacuum* method, exemplified in the Loughridge brake, the air is exhausted from the device beneath the car, and the pressure of the atmosphere operates the brake-levers.

**Brake.** See *Bracken*.

**Brake** (vehicle). See *Break*.

**Bram'ah**, JOSEPH, the inventor of the Bramah lock, the Bramah press, &c., born in Yorkshire in 1749, died in 1814. He set up business in London as manufacturer of various small articles in metal-work, and distinguished himself by a long series of inventions, such as improvements in paper-making, fire-engines, printing-machines, &c. He is especially known for an ingeniously constructed lock, and for the hydraulic press (which see).

**Bramah's press.** See *Hydraulic Press*.

**Bramante** (brà-màn'tā), FRANCESCO LAZARI, a great Italian architect, born in 1444. He applied himself first to painting, in which he acquired considerable renown, but at length devoted himself to architecture. He was patronized by the popes, and his first great work at Rome was the union of the straggling buildings of the Vatican with the Belvedere gardens, so as to form one fine whole. But his greatest work was the part he had in the building of the new church of St. Peter at Rome, of which he was the first architect. He died, however, in 1514, while the building was still in an early stage of construction, and his designs were much altered by succeeding architects.

**Bram'ble** (*Rubus fruticosus*), the name commonly applied to the bush with trailing prickly stems which bears the well-known berries usually called in Scotland brambles, and in England blackberries. It is similar to the raspberry, and belongs to the same genus, natural order Rosaceæ. It is rarely cultivated, but as a wild plant it grows in great abundance. The flowers do not appear till late in the summer, and the fruit,

which is deep purple or almost black in colour, does not ripen till autumn.

**Bram'bling**, or BRAMBLE-FINCH, the mountain-finch (*Fringilla montifringilla*), larger than the chaffinch, and very like it. It breeds in the north of Scandinavia, and visits Britain and the south of Europe in winter.

**Brampton**, an ancient town, England, county Cumberland, with tweed manufactures. Pop. 1891, 5404.

**Bran**, the husky part of wheat separated by the bolter from the flour. Its components are: water, 13; gluten, 19.5; fatty matter, 5; husk with starch, 55; and ashes, 7.5; but the results of different analyses vary considerably. It is employed in feeding cattle, and has also been found useful as a manure.

**Branchiæ** (brang'ki-ē). See *Gills*.

**Branchiogasterop'oda** (brang-ki-), gasteropodous molluscs whose respiration is aquatic, being generally effected by means of external branchiæ or gills. They include a great many animals with univalve shells, as whelks, limpets, cone-shells, periwinkles, cowries, &c., also sea-hares, sea-slugs, sea-lemons, and the heteropoda.

**Branchiop'oda** (brang-ki-), an order of crustaceous animals, so called because their branchiæ, or gills, are situated on the feet. They have one to three masticating jaws, and the head is not distinct from the thorax, which is much reduced in size. They include the water-fleas, trilobites, phyllopod, &c.

**Branchios'toma**, or LANCELET, also called *Amphioxus*. See *Lancelet*.

**Branco**, RIO, a river of N. Brazil, a tributary of the Rio Negro.

**Brand** is a provincial name for certain diseases of cereals, applied generically. Thus bunt is called *pepper-brand*, and smut is called *dust-brand*. The name is also given to a disease in vegetables, by which their leaves and tender bark are partially destroyed as if they had been burned.

**Bran'denburg**, a province of Prussia, surrounded mainly by Mecklenburg and the provinces of Pomerania, Posen, Silesia, and Prussian Saxony. The soil consists in many parts of barren sands, heaths, and moors; yet the province produces much grain, as well as fruits, hemp, flax, tobacco, &c., and supports many sheep. The forests are very extensive. The principal streams are the Elbe, the Oder, the Havel, and the Spree. Berlin is locally in Brandenburg.

Area, 15,400 sq. miles; population, 1890, was 4,120,577, including the city of Berlin. The Old Mark of Brandenburg was bestowed by the Emperor Charles IV. on Frederick of Hohenzollern, and is the centre round which the present extensive kingdom of Prussia has grown up.—The town BRANDENBURG is on the Havel, 35 miles w.s.w. of Berlin. It is divided into three parts—an old town, a new town, and a cathedral town—by the river, and has considerable manufactures, including silk, woollens, leather, &c. Pop. 33,129.

**Brandenburg, NEW**, a town of Germany, in Mecklenburg-Strelitz, with a grand-ducal palace. Pop. 8406.

**Brand'ing**, a form of punishment once in use in England for various crimes, but abolished in 1822. It was performed by means of a red-hot iron, and the part which was branded was the cheek, the hand, or some other part of the body. Even after branding had been abolished in all other cases, a milder form of it was for a long time retained in the army as a punishment for desertion, the letter D being marked with ink or gunpowder on the left side of a deserter 2 inches below the armpit. This also has been abolished.

**Bran'dis, CHRISTIAN AUGUST**, German scholar, born in 1790, died in 1867. After studying at Kiel and Göttingen he was induced by Niebuhr to accompany him to Rome as secretary to the Prussian embassy. In 1822 he was made professor of philosophy at the University of Bonn. From this date his name became well known as that of a contributor to the learned journals of Germany, till in 1835 the appearance of the first part of his great work on the History of Greek and Roman Philosophy acquired for him a European reputation. In 1837–39 he held an appointment at the court of Greece.

**Brand'ling** is a species of fish, the parr or young of the salmon, so named from its markings being, as it were, branded. The name is also given to a small red worm used for bait in fresh-water fishing.

**Bran'don**, a rising town of Canada, in Manitoba, 132 m. west of Winnipeg. Pop. 3500.

**Brandt (bränt)**, or BRANT, SEBASTIAN, author of a famous German satire, the *Narrenschiiff*, or Ship of Fools. He was born at Strasburg in 1458, and studied law at Basel, dying in 1521. The *Narrenschiiff* is written in verse, and is a bold and vigorous satire

on the vices and follies of the age. It took the popular taste of its time, and was translated into all the languages of Europe. The Ship of Fools by Alexander Barclay (1509) is partly an imitation, partly a translation of it.

**Brandy**, the liquor obtained by the distillation of wine, or of the refuse of the wine-press. It is colourless at first, but usually derives a brownish colour from the casks in which it is kept or from colouring matters added to it. The best brandy is made in France, particularly in the Cognac district in the department of Charente. Much of the so-called brandy sold in Britain and America is made there from more or less coarse whisky, flavoured and coloured to resemble the real article; and France itself also exports quantities of this stuff. In 1889 the brandy imported into the port of New York was 328,212 gallons, valued at \$6 per gal., but two or three times this quantity came into other ports, almost all of it from France. The duty on it at present is \$2.50 the gallon. Brandy is often used medicinally as a stimulant, stomachic, and restorative, or in mild diarrhoea. In America various distilled liquors get the name of brandy, as cider brandy, peach brandy.

**Brandywine Creek**, a small river which rises in the state of Pennsylvania, passes into the state of Delaware, and joins Christiana Creek near Wilmington. It gives its name to a battle fought near it, Sept. 11, 1777, between the British and Americans, in which the latter were defeated.

**Brank**, or BRANKS, an instrument formerly in use in Scotland, and to some extent also in England, as a punishment for scolds. It consisted of an iron frame which went over the head of the offender, and had in front an iron plate which was inserted in the mouth, where it was fixed above the tongue, and kept it perfectly quiet.

**Brank'ursine**. See *Acanthus*.

**Brant**. See *Brandt*.

**Brant'ford**, a flourishing town of Canada, prov. Ontario, on the Grand River (which is navigable), 24 m. w.s.w. of Hamilton; it has railway machine-shops, foundries, and an active trade. Pop. 1891, 12,753.

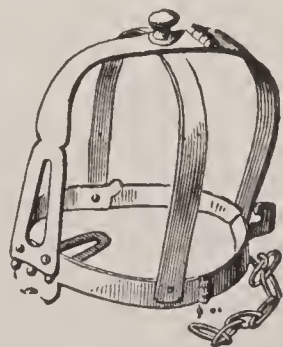

Brank.

**Brantôme** (brān-tōm), **PIERRE DE BOURDEILLES, SEIGNEUR DE**, French writer, born in Perigord about 1540, died in 1614. He was of an old and noble family, and early entered the profession of arms. After a brilliant life in courts and camps he withdrew to his estate in Perigord, and spent his time in writing memoirs, which give an admirable picture of an age, with particulars which a chaster and more fastidious pen could hardly have set down. His memoirs consist of *Vies des Hommes illustres et des grands Capitaines Français*; *Vies des grands Capitaines Étrangers*; *Vies des Dames illustres*; *Vies des Dames galantes*.

**Brasenose**, one of the colleges of Oxford University, founded by William Smith, bishop of Lincoln, and Sir Richard Sutton, in 1509. The origin of the name is doubtful, but there is a large nose of brass over the entrance. The college is very rich in endowments.

**Brasidas**, a Spartan general who in the Peloponnesian war overthrew the Athenian army under Cleon at Amphipolis, but was himself mortally wounded, B. C. 422.

**Brass** is an alloy of copper and zinc, of a bright-yellow colour, and hard, ductile, and malleable. The best brass consists of two parts by weight of copper to one of zinc; but any degree of variation may be obtained by altering the proportions; thus by increasing the quantity of zinc we may form *tombac* and *pinchbeck*, and with nearly a seventh more of zinc than copper the compound becomes brittle and of a silver-white colour. By increasing the copper, on the other hand, the compound increases in strength and tenacity. Brass which is to be turned or filed is made workable by mixing about 2 per cent of lead in the alloy, which has the effect of hardening the brass and preventing the tool being clogged. For engraving purposes a little tin is usually mixed with the brass. Brass is used for a vast variety of purposes, both useful and ornamental. Birmingham is the chief seat of the trade in this metal.

**Bas'sarts**, pieces of ancient plate armour which united the armour-plates on the shoulder and elbow. Demi-brassarts shielded only the front.

**Brasses**, **SEPULCHRAL OR MONUMENTAL**, large plates of brass inlaid in polished slabs of stone, and usually exhibiting the figure of the person intended to be commemorated, either in a carved outline on the plate or in the form of the plate itself. In

place of the figure we sometimes find an ornamented cross. The earliest example of these monumental slabs now existing in England is that on the tomb of Sir John D'Abernon (died 1277) at Stoke D'Abernon in Surrey. These brasses are of great value in giving us an exact picture of the costume of the time to which they belong.

**Brasseur de Bourbourg** (brä-seur dé bōr-bōr), **CHARLES ÉTIENNE**, French writer on American history, archæology, and ethnology, born 1814, died 1874. He entered the priesthood, was sent to North America by the Propaganda, and lived and travelled here and in Central America



Brass.—Westminster Abbey.

for a number of years, partly in the performance of ecclesiastical functions. Among his works are *Histoire du Canada* (1851), *Histoire des Nations civilisées du Mexique et de l'Amérique Centrale* (1857-58), *Grammatica de la Lengua Quiche* (1862), *Monuments anciens du Mexique* (1864-66), *Études sur le Système graphique et la Langue des Mayas* (1869-70), &c.

**Brassey**, **THOMAS**, an English railway contractor, born 1805, died 1870. His operations were on an immense scale, and extended to most of the European countries, as well as to America, India, and Australia, one of his greatest works being the Grand Trunk Railway of Canada, with the great bridge over the St. Lawrence at Montreal. He left a very large fortune. His son, Thomas, born 1836, now Lord Brassey, was civil lord of the admiralty in 1880-84. His wife wrote *Voyage of the Sunbeam* and other works descriptive of yachting cruises and travels. She died in 1888.

**Bras'sica**, an important genus of cruciferous plants, including among its numerous species many of great economical value, as

## BRATTLEBORO — BRAZIL.

the cabbage, turnip, rape, &c. Owing to the numerous crossed races which have been produced in modern times, the limits of the species have been broken down, and often cannot easily be recognised.

**Brattleboro**, Windham county, Vt., is one of the richest towns in the State; site of the State Insane Asylum; has 2 banks, several churches and factories, 4 papers. Pop. in 1890, 6857.

**Braunsberg** (bronz'berg), a town, Prussia, government of Königsberg, on the Passarge, about 4 miles from its junction with the Frische Haff. Pop. 11,577.

**Brauwer** (brou'ver), ADRIAN. See *Brouwer*.

**Bravi** (brä'vē), the name formerly given in Italy, and particularly in Venice, to those who were ready to hire themselves out to perform any desperate undertaking. The word had the same signification in Spain, and both the word and the persons designated by it were found in France in the reign of Louis XIII. and during the minority of Louis XIV.

**Bravo** (brä'vō), an Italian adjective used as exclamation of praise in theatres, meaning 'well done! excellent!' The correct usage is to say *bravo* to a man, *brava* to a woman, *bravi* to several persons.

**Bravu'ra Air**, an air so composed as to enable the singer to show his skill in execution by the addition of embellishments, striking cadences, &c.

**Brawn**, a preparation made from the flesh of swine freed from all bones, formed into a roll, boiled, and pressed. Wiltshire brawn is in much repute.

**Braxy**, a disease of sheep, being a plethora of the blood resulting from a change from poor to rich pasturage, usually fatal in a few hours. The flesh of sheep that die of this disease is often eaten in Scotland.

**Bray**, a watering-place in Ireland, partly in co. Dublin and partly in Wicklow, picturesquely situated on both banks of the Bray, 12 miles S.E. of Dublin. Pop. 6535.

**Brazil'**, a republic in South America, occupying a space nearly equal to one-half of that continent; greatest length, E. to W., 2630 miles; greatest length, N. to S., 2540 miles; area estimated at 3,300,000 square miles, or about one-sixth smaller than Europe. It is bounded S.E., E., and N.E. by the Atlantic Ocean, N. by French, Dutch, and English Guiana, and Venezuela; W. and S.W. by Ecuador, Peru, Bolivia, Paraguay, the Argentine Confederation, and the Re-

public of Uruguay. Brazil is divided politically into 21 provinces, of which there are at least ten, each exceeding Britain in superficial extent. The population, 1890, is 14,002,335.

The coast has few indentations of importance—the chief being the estuaries of the Amazon and Pará in the north—and good harbours are comparatively few. As a whole the country may be regarded as having three natural divisions, namely, one belonging to the basin of the Amazon, another belonging to the La Plata basin, and a third consisting of the eastern portion watered by a number of streams directly entering the Atlantic. The Amazon valley is bounded by elevated table-lands which, in the lower course of the river, approach within a comparatively short distance of each other. The characteristic feature of this region is its immense low-lying, forest-covered plains, intersected by innumerable water-courses, and in many parts subject to annual inundation, the vegetation being of the most luxuriant character, from the heat and frequent rains. The greater part of this vast region is unpopulated except by Indians, and as yet of little commercial importance. The climate, notwithstanding the tropical heat and moisture, is comparatively healthy, and the facility for commerce given by thousands of miles of great navigable streams must in time attract numerous settlers. To some extent this has already taken place in the region of the Lower Amazon. Here the development of a trade in the juice of the india-rubber trees, which grow in vast quantities, has attracted thousands of Brazilians from the adjoining provinces, and thus 'has covered thousands of miles of rivers with steamers, and spread a population over vast areas that otherwise would have remained dormant for many years.' This northern part of Brazil is unequalled in the number and magnitude of the streams which compose its river system and connect it with Venezuela, Colombia, Ecuador, Peru, and Bolivia. On the north side the chief affluents of the Amazon are the Rio Negro and the Japura, the former giving through the Cassiquiare continuous water communication with the Orinoco. Amongst the southern affluents which are important as water highways into the interior of Brazil are the Xingu, the Tapajos, the Madeira, the Purus, and the Jurua; the Madeira being the most important, and forming a navigable waterway into Bolivia,

## BRAZIL.

except that it is interrupted by falls about 200 miles below where it enters Brazil. The Tocantins is another large stream from the south, which enters the Pará estuary and hardly belongs to the Amazon basin. The forest region of the Amazon occupies about one-fourth of the empire; the rest is made up of undulating table-lands 1000 to 3000 feet above the sea, mountain ranges rising to 10,000 feet, and river valleys.

The great streams belonging to the La Plata basin, in the south, are the Paraguay and Paraná. The water-shed between this and the Amazonian basin, near the western boundary of Brazil, is only about 500 feet above sea-level, and here a canoe can be hauled across from a head-stream of the Madeira to be launched on one belonging to the Paraguay. It would thus be easy to connect the one system with the other by means of a canal, and so connect the La Plata with the Orinoco. The water-shed rises gradually from west to east. The southern part of Brazil is characterized by its low plains or *pampas*, covered with grass or scrub. Its vegetation is of a much less tropical character than in the Amazon basin, and its climate more variable. In many parts of this region there is an admirable field for future colonization, though it is as yet defective in means of transport. Near the coast, in the provinces of S. Paulo, Rio Grande, and Paraná, there is already a considerable population, much augmented by German and Italian immigration, and mostly occupied in cattle-raising and agriculture. Railways also have been constructed here and given a great stimulus to trade.

The most important river in eastern Brazil is the San Francisco, which is the great water-way into its interior, and after a course of 1800 miles discharges its waters into the Atlantic at San Antonio. The three greatest cities of Brazil, Rio de Janeiro, Pernambuco, and Bahia, are all endeavouring to develop a traffic in connection with this river. A state line has now been constructed round the falls of Pedro Affonso on its lower course, and thus brought the traffic of the upper river into communication with the lower. Eastern Brazil exhibits a great variety in surface, climate, and productions, and though large tracts consist of arid and sandy table-lands, it contains within itself the greater part of the population, wealth, and industry of the empire.

The chief mountain ranges are near the

south-eastern coast. The Serra do Mar or Maritime range commences in the far south, and travels close to the coast-line in a north-easterly direction till it reaches Rio de Janeiro and Cape Frio, where it culminates in the Serra dos Orgãos, or Organ Mountains, from 7000 to 8000 feet above the sea, and forming the noblest element in the marvellous scenery of the bay of Rio de Janeiro. West of the Serra do Mar lies the Serra Mantiqueira, which farther north is known as the Serra do Espinhaço. Here are the loftiest summits in Brazil, Itatiaia-Assu, the highest of all, being 10,040 feet above the sea. Between the sources of the Tocantins and Paraná are the Montes Pyreneos, the second most elevated ridge in Brazil, some of its heights being estimated at nearly 8000 and 10,000 feet above the level of the sea.

As almost the whole of Brazil lies s. of the equator, and in a hemisphere where there is a greater proportion of sea than land, its climate is generally more cool and moist than that of countries in corresponding latitudes in the northern hemisphere. In the s. parts of Brazil, in consequence of the gradual narrowing of the continent, the climate is of an insular character—cool summers and mild winters. The quantity of rain differs widely in different localities. The n. provinces generally are subject to heavy rains. At Rio, where the climate has been much modified by the clearing away of the forests in the neighbourhood, the mean temperature of the year is 74°. At Pernambuco the temperature rarely exceeds 82°; in winter it descends to 68°. Generally the climate of Brazil is delightful.

Only an insignificant portion of Brazil is as yet under cultivation. The pastures are of vast extent, and support great herds of horned cattle, one of the principal sources of the wealth of the country. The chief food-supplying plants are sugar, coffee, cocoa, rice, tobacco, maize, wheat, manioc (or cassava), beans, bananas, ginger, yams, lemons, oranges, figs, &c.—the two first, sugar and coffee, being the staple products of the empire. As much coffee, indeed, is produced in Brazil as in all the rest of the world together. In its forests Brazil possesses a great source of wealth. They yield dyewoods and fancy woods of various kinds, including Brazil-wood, rosewood, fustic, cedar, mahogany, and a variety of others, as also Brazil-nuts, coco-nuts, vegetable ivory, india-rubber, copaiba, arnotto, piassava fibre, &c. Other



## BRAZIL.

vegetable products are vanilla, sarsaparilla, ipecacuanha, cinnamon, and cloves.

The principal domestic animals of Brazil are horned cattle and horses. Sheep are kept only in some parts, chiefly in the south. Goats and hogs are abundant. The wild animals comprise the puma, jaguar, sloth, porcupine, &c. Monkeys are numerous. Amongst the feathered tribes are the smallest, the humming-bird, and one of the largest, the rhea, parrots in great variety, tanagers, toucans, and the harpy eagle. The reptiles consist of the boa-constrictor and other species of serpents, some of them venomous, alligators, and fresh-water turtle, the eggs of which yield a valuable oil. The insects are, many of them, remarkable for the beauty of their colours and their size, especially the butterflies. Amongst the most notable are the white-ant, very numerous and very destructive, and the scorpion, which attains a length of 6 inches. Among minerals the diamonds and other precious stones of Brazil—emeralds, sapphires, rubies, beryls, &c.—are well known. Gold also is procured in considerable quantities. Other minerals are quicksilver, copper, manganese, iron, lead, tin, antimony, and bismuth. The shores and rivers abound with fish.

The population of Brazil consists of whites, Indians, negroes, and people of mixed blood. The native Brazilians, mostly descendants of the Portuguese settlers, but often with a mixture of Indian or African blood, are said to be greatly wanting in energy. The white population, which is, perhaps, a third of the whole, has in recent years been increased by Italian, Portuguese, and German immigration. The negroes are over 2,000,000 in number, and till 1888 were partly slaves. Of the Indians some are semi-civilized, but others (estimated at 600,000) roam about in a wild state, and are divided into a great many tribes speaking different languages. The state language is Portuguese. Primary education is gratuitous, but the great majority of the people are illiterate, though education is now compulsory in some provinces.

The principal imports are cottons, linens, woollens, machinery, hardware and cutlery, wheat, flour, wine, coals, &c., the manufactured articles and coals being largely from Britain. The exports consist of coffee, sugar, cotton, hides, cabinet and dye woods, drugs, caoutchouc, and diamonds. The main export is coffee, the total value exported annu-

ally being about \$75,000,000. The total value of exports and imports is usually about \$100,000,000 each. The imports from Great Britain amounted in 1891 to £8,290,039 (£2,573,083 being cotton goods), and the exports to £4,249,909. The chief money of account is the milreis (1000 reis), equivalent at par to 54 cents. The English sovereign is legal tender at 8889 reis each. The length of telegraph lines in Brazil in 1891 was 17,400 miles, and of railways about 5000.

The established religion of Brazil is Roman Catholic, although other religions are tolerated. The government previous to 1889 was hereditary-monarchical; when by a revolution Emperor Dom Pedro II. was dethroned and Brazil declared a republic. In 1890 the provisional government convoked a national congress, which, in 1891, established a new constitution, whereby the Brazilian nation, adopting the federative republican form of government, constituted itself as the U. States of Brazil. In 1892 the public debt was stated as \$573,460,851. The revenue is usually about \$60,000,000 or \$65,000,000. The standing army numbers 30,500. The navy in 1892 comprised 10 iron-clads, besides 15 torpedo-boats and 5 first and second-class cruisers.

Brazil was discovered in 1499 by Vincente Yanez Pinçon, one of the companions of Columbus in the service of Spain, and next year was taken possession of by Pedro Alvares de Cabral on behalf of Portugal. The first governor-general was Thome de Sousa, who in 1549 arrived in the Bay of Bahia and established the new city of that name, making it the seat of his government. The usurpation of the crown of Portugal by Philip II. left Brazil in a defenceless and neglected condition, and the English, French, and Dutch made successive attempts to obtain a footing. The Dutch were the most persevering, and for a time almost divided the Brazilian territory with the Portuguese. The tyranny of the Dutch governors, however, incited their native and Portuguese subjects to revolt, and after a sanguinary war, in 1654 the Dutch were driven out and the Portuguese remained masters of an undivided Brazil. The value of Brazil to Portugal continued steadily to increase after the discovery of the gold mines in 1698 and the discovery of the diamond mines in 1728. The vigorous policy of the Portuguese government under the administration of the Marquis de Pombal (1760–77) did much to open up the interior of Brazil,

## BRAZIL — BREACH.

though his high-handed modes of procedure left amongst the Brazilians a discontent with the home government which took shape in the abortive revolt of 1789. On the invasion of Portugal in 1808 by the French the sovereign of that kingdom, John VI., sailed for Brazil, accompanied by his court and a large body of emigrants. He raised Brazil to the rank of a kingdom, and assumed the title of King of Portugal and Brazil. But on his return to Portugal in 1820 he found the Portuguese Cortes unwilling to grant civil and political equality to the Brazilians—a fact which raised such violent convulsions in Rio Janeiro and other parts of Brazil that Dom Pedro, the king's son, was forced to head the party resolved to make Brazil independent, and in 1822 a national assembly declared the separation of Brazil from Portugal, and appointed Dom Pedro the constitutional emperor. In 1864 began a severe struggle between Brazil and Paraguay, caused principally by the arbitrary conduct of Lopez, the dictator of Paraguay. Brazil had to bear the brunt of the war, which terminated only with the death of Lopez in 1870. This struggle secured the freedom of the navigation of the La Plata river-system. In 1888 slavery was finally abolished. Marshal da Fonseca, first president of Brazil, resigned in 1891, and was succeeded by Floriano Peixoto. A revolt, led by Admiral Mello, occurred in 1893, during which Rio Janeiro was bombarded and Peixoto's retirement demanded. In November, 1894, a new president, Prudente Moraes, took office, and his policy of peace and reconciliation apparently proved successful, especially in pacifying the disturbed state of Rio Grand do Sul.

**Brazil, Clay co., Ind., has iron manuf., woolen, planing and flour mills, and mines of excellent coal. Pop. 1890, 5905.**

**Brazilian Grass**, a name popularly and incorrectly given to a substance which is obtained from the palm *Chamærops argentæa*, and which is imported for manufacturing purposes. See *Chamærops*.

**Brazil-nuts**, the seeds of *Bertholletia excelsa*. See *Bertholletia*.

**Brazil-tea**, a name for maté.

**Brazil-wood**, a kind of wood yielding a red dye, obtained from several trees of the genus *Cæsalpinia*, order Leguminosæ, natives of the West Indies and Central and South America. The best kind is *Cæsalpinia echināta*; other varieties are *C. brasiliensis*, *C. crista*, and *C. Sappan*. The wood is

hard and heavy, and as it takes on a fine polish it is used by cabinet-makers for various purposes, but its principal use is in dyeing red. The dye is obtained by reducing the wood to powder and boiling it in water, when the water receives the red colouring principle, which is a crystallizable substance called *brazilin*. The colour is not permanent unless fixed by suitable mordants.

**Bra'zing**, or BRASS-SOLDERING. See *Soldering*.

**Brazos** (brä'zōs), a large river, United States, Texas, rising in the N.W. part of the state, and flowing into the Gulf of Mexico, after a course of 900 miles, 40 miles W.S.W. Galveston. During the rainy season, from February to May inclusive, it is navigable by steam-boats for about 300 miles.

**Brazza** (brät'sà), an island in the Adriatic, part of Dalmatia, 24 miles long and from 5 to 7 broad, mountainous and well wooded. It produces good wines and oil, almonds, silk, &c. Pop. about 20,000.

**Breach**, the aperture or passage made in the wall of any fortified place by the ordnance of the besiegers for the purpose of entering the fortress.—*Breaching batteries* are batteries of heavy guns intended to make a breach.

**Breach**, in law, any violation of a law, or the non-performance of a duty imposed by law. Breaches are of various kinds:—*Breach of Close*, in English law, any entry upon another man's property which is not warranted by being made in the exercise of a right.—*Breach of Covenant*, the act of violating an agreement in a deed either to do or not to do something.—*Breach of Peace* is an offence against the public safety or tranquillity either personally or by inciting others. Breaches of peace are such as affrays, riots, routs, and unlawful assemblies, forcible entry or detainer by violently taking or keeping possession of lands or tenements with menaces, force, and arms; riding, or going, armed with dangerous or unusual weapons, terrifying people; challenging another to fight, or bearing such a challenge, besides certain other offences.—*Breach of Promise* (of marriage), the failure to implement one's promise to marry a particular person, in consequence of which that person may raise an action for damages, though it is only the woman as a rule that gains damages.—*Breach of Trust* is a violation of duty by a trustee, executor, or any other person in a fiduciary position as, for in-

## BREAD.

stance, when a trustee manages an estate intrusted to him for his own advantage rather than for that of the trust.

**Bread** is the flour or meal of grain kneaded with water into a tough and consistent paste and baked. There are numerous kinds of bread, according to materials and methods of preparation; but all may be divided into two classes: *fermented, leavened, or raised, and unfermented, unleavened, not raised.* The latter is the simplest, and no doubt was the original kind, and is still exemplified by biscuits, the oat-cakes of Scotland, the corn-bread of America, the *dampers* of the Australian colonies, and the still ruder bread of savage races. It was probably by accident that the method of bringing the paste into a state of fermentation was found out, by which its toughness is almost entirely destroyed, and it becomes porous, palatable, and digestible. All the cereals are used in making bread, each zone using those which are native to it. Thus maize, millet, and rice are used for the purpose in the hotter countries, rye, barley, and oats in the colder, and wheat in the intermediate or more temperate regions. In the most advanced countries bread is made from wheat, which makes the lightest and most spongy bread. The fermentation necessary for the ordinary loaf-bread is generally produced by means of leaven or yeast, and the first thing to be done towards the manufacture of a batch of bread is, in the language of the baker, *to stir a ferment.* For this purpose water, yeast, flour, and some potatoes mashed and strained through a cullender, are mixed together and worked up into a thin paste, in which, on being left at rest for a time, an active fermentation sets in, the carbonic acid generated causing the mixture to rise and fall. In about three hours the fermenting action is at rest, and the mixture may now be used, but it is not generally used till at the end of four or five hours. The next operation is called *setting the sponge.* This consists in stirring up the above ferment well, adding some lukewarm water, and mixing in as much flour as will make the whole into a pretty stiff dough, which receives the name of the *sponge.* The sponge being kept in a warm place begins to ferment in the course of an hour or so, heaving and swelling up till at last the imprisoned carbonic acid bursts from the mass, which then sinks or collapses. This is called *the first sponge,* and from it the bread may be made; but the fermentation is often

allowed to proceed, and the rising and falling to go on a second time, producing what the bakers call *the second sponge.* The next process is called *breaking the sponge,* and consists in adding to it the requisite quantity of water and salt, the sponge being thoroughly mixed up with the water. The remainder of the total quantity of flour intended to be employed is gradually added, and the whole is kneaded into a dough of the due consistency. The dough being allowed to remain in the trough till it rise or *give proof,* is then weighed off into lumps, which are shaped into loaves and placed in the oven. In the process of baking they swell to about double their original size. The chemical changes which have been taking place during this process may be explained in the following way: An average quality of flour consists of gluten 12, starch 70, sugar 5, gum 3, water 10; total, 100. When water is added to the flour, in the first operation of baking, it unites with the gluten and starch, and dissolves the gum and sugar. The yeast or barm added acts now upon the dissolved sugar, especially at an elevated temperature, and produces the vinous fermentation, forming alcohol and setting free carbonic acid as a consequence of the transformation of the elements of the sugar. The gaseous carbonic acid is prevented from escaping by the gluten of the mass, and if the mixing or kneading has been properly performed it remains very equally diffused through every part of the dough. The alcohol and carbonic acid are carried into the oven with the dough, and the former partially escapes, while the latter gas, being expanded by the heat, produces the lightness and sponginess of the loaf. It may be produced in bread-making by other means than fermentation, as by some of those well-known preparations called 'baking powders,' which usually contain bicarbonate of potash or of soda, with tartaric acid. *Aërated bread* is so called because made with aërated water—that is, water strongly impregnated with carbonic acid under pressure, the dough being also worked up under pressure and caused to expand by the carbonic acid when the pressure is removed.

The several qualities of flour used for bread-making are known by the names of *firsts* or *whites, seconds* or *households, and thirds,* according to the degree of fineness resulting from the process of bolting or dressing. The latter two contain a certain proportion of the bran. *Brown* or *whole-*

*flour* bread is considered to be very wholesome. It is made from undressed wheat, and consequently contains the bran as well as the flour.

Various adulterations are found in bread, such as chalk, starch, potatoes, &c.; but the commonest is alum, which enables the baker to give to bread of inferior flavour the whiteness of the best bread, and also to keep in the loaf an undue quantity of water, which, of course, increases its weight. Boiled rice is also used for the same purpose. In Britain bakers adulterating bread are liable to a penalty of not more than £10 and not less than £5 for every offence, and to have their names advertised in the newspapers. In the making of bread the flour or meal of wheat, barley, rye, oats, buckwheat, Indian corn, rice, beans, pease, and potatoes may be used, along with salt, eggs, water, milk, and leaven or yeast of any kind; but any other ingredient is regarded as an adulteration. All bread except French or fancy bread and rolls must be sold by weight (*avoirdupois*), and bakers must provide a beam and scales with weights for the purpose of weighing it if required. Bread made wholly or partially of any other flour or grain than that of wheat must be stamped with the letter M. The penalty of adulterating flour or meal is not more than £20 nor less than £5.

**Breadal'bane**, a Highland district in the western part of Perthshire, in the centre of the Grampians. It gives his title to the Marquis of Breadalbane, head of a branch of the Campbell family, who is the chief proprietor here.

**Bread-fruit**, a large globular fruit of a pale-green colour, about the size of a child's head, marked on the surface with irregular six-sided depressions, and containing a white and somewhat fibrous pulp, which when ripe becomes juicy and yellow. The tree that produces it (*Artocarpus incisa*) belongs to the order *Artocarpaceæ* (nearly allied to the *Urticaceæ* or nettle tribe), and grows wild in Otaheite and other islands of the South Seas, whence it was



Bread-fruit.

introduced into the West Indies and S. America. It is about 40 feet high, with large and spreading branches, and has large bright-green leaves deeply divided into seven or nine spear-shaped lobes. The fruit is generally eaten immediately after being gathered, but is also often prepared so as to keep for some time either by baking it whole in close underground pits or by beating it into paste and storing it underground, when a slight fermentation takes place. The eatable part lies between the skin and the core, and is somewhat of the consistence of new bread. Mixed with cocoa-nut milk it makes an excellent pudding. The inner bark of the tree is made into a kind of cloth. The wood is used for the building of boats and for furniture. The jack (*Artocarpus integrifolia*), much used in India and Ceylon, is another member of this genus.

**Bread-nuts**, the seeds of the *Brosimum alicastrum*, a tree of the same order as the bread-fruit (which see). The bread-nut tree is a native of Jamaica. Its wood, which resembles mahogany, is useful to cabinet-makers, and its nuts make a pleasant food, in taste not unlike hazel-nuts.

**Bread-root**, *Psoralëa esculenta*, a leguminous plant of the United States, with edible farinaceous tubers.

**Break**, or **BRAKE**, a large four-wheeled vehicle with a straight body and a raised seat in front for the driver, and containing seats for six, eight, or more persons.

**Breaking bulk**, the act of beginning to unlade a ship, or of discharging the first part of the cargo.

**Break'water**, a work constructed in front of a harbour to serve as a protection against the violence of the waves. The name may also be given to any structure which is erected in the sea with the object of breaking the force of the waves without and producing a calm within. Breakwaters are usually constructed by sinking loads of unwrought stone along the line where they are to be laid, and allowing them to find their angle of repose under the action of the waves. When the mass rises to the surface, or near it, it is surmounted with a pile of masonry, sloped outwards in such a manner as will best enable it to resist the action of the waves. The great breakwaters are those of Cherbourg in France, Plymouth in England, and Delaware Bay in N. America. In England those at Holyhead and Portland may also be mentioned as great works of engineering. At Dover a breakwater has been

going on since 1844 at an enormous outlay, but has not yet been completed, the great depth and frequent storms being formidable obstacles. In less important localities floating breakwaters are occasionally used. These are built of strong open woodwork, partly above and partly under water, divided into several sections, and secured by chains attached to fixed bodies. The breakers lose nearly all their force in passing through the beams of such a structure. A breakwater of this kind may last for twenty-five years.

**Bream** (*Abramis brama*), a fish sometimes called carp-bream, belonging to the family Cyprinidæ or carps. It is about 2 to 2½ feet long, and of a yellowish-white colour. It is found in many European lakes and rivers, and affords good sport to the angler, but is a very coarse and insipid food. It prefers still water with a bottom of soft soil, and feeds both on animal and vegetable matter. It is little known in Scotland,

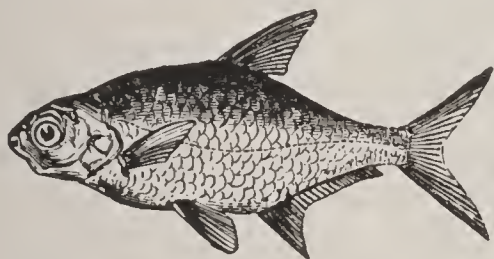

Bream.

though common in many parts of England and Ireland. The name is also given to various kinds of sea-fishes, mostly of the family Sparidæ, as the black sea-bream, the common sea-bream or gilthead, the short sea-bream, &c.

**Breaming**, a nautical term meaning the operation of clearing a ship's bottom by means of fire of the shells, sea-weeds, barnacles, &c., that have become attached to it. It is performed by holding to the hull kindled furze, reeds, or such like light combustibles, so as to soften the pitch and loosen the adherent matters, which may be then easily swept off.

**Breast**, THE FEMALE, is of a glandular structure, containing vesicles for the secretion of milk, and excretory ducts, which open by small orifices in the nipple, and discharge the secreted fluid for the nourishment of the child. At the centre of each breast there is a small projection, the nipple, and this is surrounded by a dark ring termed the areola. The breast is liable to many diseases, from irritation during nursing, bruises of the part, undue pressure from

tight clothes, and from constitutional causes. Amongst the most common of these is inflammation arising from a superabundant secretion of milk during nursing.

**Breastplate**, a piece of defensive armour covering the breast, made of leather, brass, iron, steel, or other metals. Among the ancient Jews the name was given to a folded piece of rich, embroidered stuff worn by the high-priest. It was set with twelve precious stones bearing the names of the tribes.

**Breast-wheel**, a water-wheel in which the water driving it is delivered to the float-

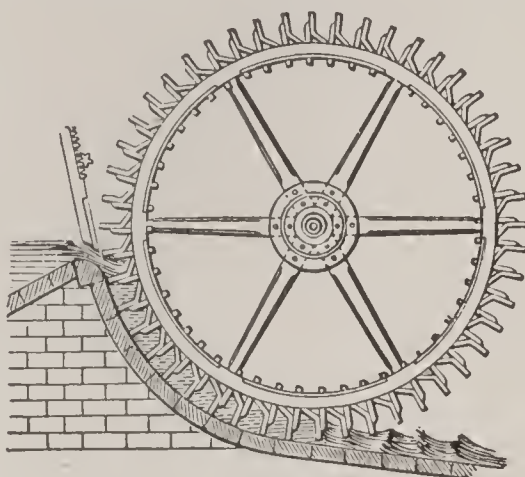

Breast-wheel.

boards between the top and bottom, generally a little below the level of the axis. In this kind of wheel the water acts partly by impulse, partly by weight.

**Breast-work**, in the military art, a hastily-constructed parapet made for protection against the shot of the enemy, generally of earth.

**Breath**, the air which issues from the lungs during respiration through the nose and mouth. A smaller portion of oxygen and a larger portion of carbonic acid are contained in the air which is exhaled than in that which is inhaled. There are also aqueous particles in the breath, which are precipitated by the coldness of the external air in the form of visible vapour; likewise other substances which owe their origin to secretions in the mouth, nose, windpipe, and lungs. These cause the changes in the breath which may be known by the smell. A bad breath is often caused by local affections in the nose, the mouth, or the windpipe; viz. by ulcers in the nose, cancerous *polypi*, by discharges from the mouth, by sores on the lungs, or peculiar secretions in them. It is also caused by rotten teeth, by impurities in the mouth, and by some kinds of food. The remedies of course vary. Frequent

washing, gargles of chlorine-water, charcoal, &c., are prescribed according to the disease.

**Breathing.** See *Respiration*.

**Breccia** (brech'i-a), a rocky mass composed of angular fragments of the same rock or of different rocks united by a matrix or cement. Sometimes a few of the fragments are a little rounded. When rounded stones and angular fragments are united by a cement the aggregate is usually called conglomerate or pudding-stone. *Osseous breccia* is, as its name implies, composed of bones.

**Brèche-de-Roland** (brāsh-dē-rō-lāŋ), that is, 'the breach of Roland,' a mountain pass in the Pyrenees, between France and Spain, which, according to a well-known legend, was opened up by Roland, one of the paladins of Charlemagne, with one blow of his sword Durandal, in order to afford a passage to his army. It is an immense gap in the rocky mountain barrier 43 miles to the N. of Huesca.

**Brechin** (brē'chin), a royal and parliamentary burgh of Scotland, in Forfarshire, finely situated on the South Esk. It has considerable linen manufactures, two distilleries, a paper-mill, &c. It is an old town; was the seat of a Culdee college, and from the 12th century that of a bishop. There is a cathedral which dates back to the 13th century, a plain building, now the parish church, and near it is the tall round tower which, except that at Abernethy, is the only example of this kind of structure in Scotland. Almost in the town and overlooking the river stands Brechin Castle, the ancient seat of the Maules of Panmure (earls of Dalhousie). Pop. 9031.

**Brec'on**, or **BRECK'NOCK**, a county of South Wales; area 719 square miles; pop. 57,031. It is very mountainous, and is watered by the Wye, the Usk, the Taf, &c. Though rugged in its surface, nearly half of it is under cultivation or in pasture; and wool, butter, and cattle are sent into the English markets. There are extensive ironworks in the S.E., but it contains only a small part of the coal-field which extends into the adjacent counties of Monmouth and Glamorgan. Half the inhabitants still speak Welsh. It sends one member to parliament.—**BRECON**, or **BRECKNOCK**, the capital of the above county, previous to 1885 a parliamentary borough, stands near its centre, in an open valley at the confluence of the Honddu and Usk, and in the midst of the grandest scenery of South Wales. The chief trade is in connection with agriculture and the manu-

facture of iron. Mrs. Siddon and Charles Kemble were natives of Brecon. Pop. 5794.

**Breda** (brā-dä'), a town in Holland, province of North Brabant, at the confluence of the Merk and the Aa. Breda was once a strong fortress and of great military importance as a strategical position. From the 16th to the end of the 18th century Breda has an interesting military history of sieges, assaults, and captures, with which the names of the most famous generals of their time, the Duke of Parma, Maurice of Orange, the Marquis Spinola, Dumouriez, and Pichegru, &c., are connected. It was the residence for a time of the exiled Charles II. of England, and it was in the Declaration of Breda that he promised liberty of conscience, a general amnesty, &c., on his restoration.

**Bree** (brā), **MATTHÆUS IGNAZIUS VAN**, a Flemish painter, born 1773, died 1839. He painted the Death of Cato and other classical subjects, as well as scenes pertaining to modern history.

**Breckinridge**, **JOHN CABELL**, Senator and Vice-Pres. of the U. S., born near Lexington, Ky., 1821, died 1875; joined the Confederacy in 1861, was their Sec. of War.

**Breech**, **BREECH-LOADING**. The breech is the solid mass of metal behind the bore of a gun, and that by which the shock of the explosion is principally sustained. In breech-loading arms the charge is introduced here, there being a mechanism by which the breech can be opened and closed. In small arms the advantages of breech-loading for rapidity of fire, facility of cleaning, &c., have recently recommended it to general use, and its efficacy for military purposes was effectively demonstrated by the Prussian campaigns against Denmark and Austria in 1864 and 1866. Since that time every government has adopted the new system, both in small-arms and heavy ordnance, while breech-loading sporting-arms are also in general use. The chief difficulty in breech loading is to close the breech so as to prevent the escape of the highly elastic gas to which the force of the explosion is due, but the appliances of modern science and mechanical art may be said to have effectually met this difficulty. See *Cannon, Musket, &c.*

**Breeches**, an article of clothing for the legs and lower part of the body in use among the Babylonians and other ancient peoples as well as among the moderns. In Europe we find them first used among the Gauls; hence the Romans called a part of Gaul

*breeched Gaul* (*Gallia braccāta*). Trousers are longer and looser than the breeches that used to be worn.

**Breeching**, a rope used to secure a ship's gun and prevent it from recoiling too much in battle.

**Breeding**, the art of improving races or *breeds* of domestic animals, or modifying them in certain directions, by continuous attention to their pairing, in conjunction with a similar attention to their feeding and general treatment. Animals (and plants no less) show great susceptibility of modification under systematic cultivation; and there can be no doubt that by such cultivation the sum of desirable qualities in particular races has been greatly increased, and that in two ways. Individual specimens are produced possessing more good qualities than can be found in any one specimen of the original stock; and from the same stock many varieties are taken characterized by different perfections, the germs of all of which may have been in the original stock but could not have been simultaneously developed in a single specimen. But when an effort is made to develop rapidly, or to its extreme limit, any particular quality, it is always made at the expense of some other quality, or of other qualities generally, by which the intrinsic value of the result is necessarily affected. High speed in horses, for example, is only attained at the expense of a sacrifice of strength and power of endurance. So the celebrated merino sheep are the result of a system of breeding which reduces the general size and vigour of the animal, and diminishes the value of the carcass. Much care and judgment, therefore, are needed in breeding, not only in order to produce a particular effect, but also to produce it with the least sacrifice of other qualities.

Breeding, as a means of improving domestic animals, has been practised more or less systematically wherever any attention has been paid to the care of live stock, and nowhere have more satisfactory results been obtained than in Britain. One of the earliest improvers in Britain was Robert Bakewell, of Dishley, in Leicestershire, who commenced his experiments about 1745, and was very successful, especially with sheep, the celebrated Dishley breed of Leicestershire sheep having since maintained a high reputation. Quantity of meat, smallness of bone, lightness of offal; in cows, yield and quality of milk; in sheep, weight of fleece

and fineness of wool, have all been studied with remarkable effects by modern breeders.

**Breeze**, BREEZE-FLY, a name given to various flies, otherwise called gadflies, horse-flies, &c.

**Breezes**, SEA and LAND. See *Wind*.

**Bregenz** (brā'gents), chief town of Vorarlberg, Austrian Empire, 77 miles w. by n. Innsbruck, beautifully situated on a slope which rises from the Lake of Constance. It is the ancient *Brigantium*, and was once of importance as a fortified place. Pop. 4736.

**Bre'hons**, ancient magistrates among the Irish. They were hereditary, had lands assigned for their maintenance, and administered justice to their respective tribes—each tribe had one brehon—seated in the open air upon some hill or eminence. Brehon law was reduced to writing at a very early period, as is evident from the antiquity of the language in which it is written, and in the earliest manuscripts we find allusions to a revision of it said to have been made in the 5th century by St. Patrick and other learned men, who are said to have expunged from it the traces of heathenism, and formed it into a code called the *Senchus Mor*. The Brehon law was exclusively in force in Ireland until the year 1170. It was finally abolished by James I. in 1605.

**Breisach** (brī'zàh), a small but ancient town of Southern Germany, on the Rhine, in Baden, formerly a free imperial city, and a fortress of importance down to the middle of the 18th century, often being a scene of warlike operations. It is often called Old Breisach, in opposition to New Breisach, a fortress on the opposite side of the river, in Alsace. Pop. 3212.

**Breisgau** (brīs'gou), one of the most fertile and picturesque districts of Germany, in the south of Baden, in the Rhine valley, containing part of the Black Forest. Chief town, Freiburg.

**Breitenfeld** (brī'tn-felt), a village of Germany, in Saxony, 4 miles n. of Leipzig, notable as the scene of two battles of the Thirty Years' war, the first gained by Gustavus Adolphus over Tilly and Pappenheim in 1631; the second by the Swedish general Torstenson over the Imperialists commanded by Archduke Leopold and Piccolomini in 1642.

**Bremen** (brā'men), a free city of Germany, an independent member of the empire, one of the three Hanse towns, on the Weser, about 50 miles from its mouth, in

its own small territory of 98 sq. miles, besides which it possesses the port of Bremerhaven at the mouth of the river. The town is partly on the right, partly on the left bank of the Weser, the larger portion being on the former. Here is the old and business section of the town, the streets of which are narrow and crooked, and lined with antique houses, and which contains the cathedral, founded about 1050, the old Gothic council-house, with the famous wine-cellar below it, the town-hall, the merchants' house, and the old and the new exchange. The Vorstadt, or suburbs lying on the right bank outside the ramparts of the old town, are now very extensive. The manufacturing establishments consist of tobacco and cigar factories, sugar-refineries, rice-mills, iron-foundries, machine-works, rope and sail works, and ship-building yards. Its situation renders Bremen the emporium for Hanover, Brunswick, Hesse, and other countries traversed by the Weser, and next to Hamburg it is the principal seat of the export and import and emigration trade of Germany. Only small vessels can come up to the town itself; the great bulk of the shipping trade centres in Bremerhaven and Geestmünde. Bremerhaven is now a place of over 17,000 inhabitants, has docks capable of receiving the largest vessels, and is connected by railway with Bremen, where the chief merchants and brokers have their offices. The chief imports are tobacco, raw cotton and cotton goods, wool and woollen goods, rice, coffee, grain, petroleum, &c., which are chiefly re-exported to other parts of Germany and the Continent. The imports (1891), 759,763,471 marks; the exports, 714,736,065 marks. Pop. of town, 1890, 125,830; of total territory (including Bremerhaven), 180,443.

Bremen was made a bishopric by Charlemagne about 788, was afterwards made an archbishopric, and by the end of the 14th century had become virtually a free imperial city. The constitution is in most respects republican. The legislative authority is shared by a senate of eighteen citizens elected for life, and an assembly of 150 citizens elected for six years. The executive lies with the senate and senatorial committees. The revenue in 1891-92 was 16,718,749 marks, and the debt 80,283,600 marks, contracted entirely for public works.

**Bremer** (bré'mer), FREDERIKA, a Swedish novelist, born near Abo in Finland in 1802, died 1865. She early visited Paris, and at

subsequent periods of her life, up to 1861, she travelled in America, England, Switzerland, Italy, Turkey, Greece, and Palestine. She also resided for some time in Norway. She wrote an account of her travels; but her fame chiefly rests on her novels, which were translated into German and French, and into English by Mary Howitt. Among the chief of these are *Neighbours*, *The President's Daughters*, *Nina*, and *Strife and Peace*.

**Brenham**, Washington co., Texas. Pop. 1890, 5209.

**Brenner**, a mountain in the Tyrolese Alps between Innsbruck and Sterzing; height 6777 feet. The road from Germany to Italy, traversing this mountain, reaches the elevation of 4658 feet, and is one of the lowest roads practicable for carriages over the main chain of the Alps. A railway through this route was opened in 1867.

**Brennus**, the name or title of several princes of the ancient Gauls, of whom the most famous was the leader of the Senones, who invaded the Roman territory about the year 390 B.C. He conquered Etruria from Ravenna to Picenum, besieged Clusium, defeated the Romans near the Allia, sacked Rome, and besieged the capitol for six months, but ultimately retired on payment of a large amount of gold. Connected with this invasion are the well-known stories of the massacre of about eighty venerable senators who awaited the Gauls in their chairs of office in the Forum; of the salvation of the capitol by the cackling of geese; and of the throwing of the sword of Brennus into the scales when the Romans complained that the weights used by the Gauls were false. According to Polybius the Gauls returned home in safety with their booty; but according to Livy, Brennus was disastrously defeated by Camillus, a distinguished Roman exile who arrived with succour in time to save the capitol.

**Brenta**, a river in North Italy, falling, after a winding course of 112 miles, into the Adriatic. Formerly its embouchure was at Fusina, opposite Venice; but a new course was made for it.

**Brentano**, CLEMENS, a German poet and romancer, born in 1777, died in 1842. He studied at Jena, and resided successively at Frankfort, Heidelberg, Vienna, and Berlin. In 1818 he retired to the convent of Dülmen, in Münster, and the latter years of his eccentric life were spent at Ratisbon, Munich, and Frankfort-on-the-Main. He



had a powerful imagination, and his works display an elaborate satirical humour, but a curious vein of mysticism and misanthropy run through them. He was the brother of Elizabeth von Arnim, Goethe's 'Bettina.' Among his principal works are — Satires and Poetical Fancies, 1800; The Mother's Statue, 1801; The Joyous Musicians, drama, 1803; Ponce de Leon, drama, 1804; the Founding of Prague, drama, 1816; History of the Brave Caspar and the Fair Annerl, an admirable novelette, 1817; &c. Gokel, Hinkel, und Gakeleia, 1838, a satire on the times; &c.

**Brent'ford**, county town and parl. div. Middlesex, England, 7 miles w. of London, with saw-mills, pottery-works, foundries, &c. Here Edmund Ironside defeated Canute in 1016; and Prince Rupert, Colonel Hollis, in 1642. Pop. 1891, 13,736.

**Brent Goose** (*Anser Brenta* or *Bernicla*), a wild goose, smaller than the common barnacle goose and of much darker plumage, remarkable for length of wing and extent of migratory power, being a winter bird of passage in France, Germany, Holland, Great Britain, the United States, Canada, &c. It breeds in high northern latitudes; it feeds on drifting sea-weeds and saline plants, and is considered the most delicate for the table of all the goose tribe.

**Brescia** (brā'shi-à; Latin, *Brixia*), a city of North Italy, capital of the province of the same name, is beautifully situated at the foot of the Alps, and is of a quadrilateral form, about 4 miles in circuit. Its public buildings, particularly its churches, are remarkable for the number and value of their frescoes and pictures. Among its chief edifices are the new cathedral, a handsome structure of white marble, begun in 1604, the Rotonda, or old cathedral, the town-hall (La Loggia), and the Broletto, or courts. The city contains a museum of antiquities, picture-gallery, botanic garden, a fine public library, a theatre, hospital, &c. An aqueduct supplies water to its numerous fountains. Near the town are large iron-works, and its firearms are esteemed the best that are made in Italy. It has also silk, linen, and paper factories, tan-yards, and oil-mills, and is an important mart for raw silk. Brescia was the seat of a school of painting of great merit, including Alessandro Bonvicino, commonly called 'Il Morretto,' who flourished in the 16th century. The city was originally the chief town of the Cenomanni, and became the seat of a

Roman colony under Augustus about B.C. 15. It was burned by the Goths in 412, was again destroyed by Attila, was taken by Charlemagne in 774, and was declared a free city by Otho I. of Saxony in 936. In 1426 it put itself under the protection of Venice. In 1796 it was taken by the French, and was assigned to Austria by the Vienna treaty of 1815. In 1849 its streets were barricaded by insurgents, but were carried by the Austrians under General Haynau. It was ceded to Sardinia by the treaty of Zürich, 1859. Pop. 43,350. The province has an area of 1845 sq. miles; pop. 1891, 487,812.

**Breslau** (bres'lou), the third city in the German Empire and the second in the Prussian dominions, being excelled in population only by Berlin and Hamburg, is the capital of the province of Silesia, and is situated on both sides of the Oder. The public squares and buildings are handsome, and the fortifications have been converted into fine promenades. The cathedral, built in the 12th century, and the Rathhaus, or town-hall, a Gothic structure of about the 14th century, are among the most remarkable buildings. There is a flourishing university, with a museum, library of 400,000 volumes, observatory, &c. Breslau has manufactures of machinery, railway-carriages, furniture and cabinet ware, cigars, spirits and liqueurs, cotton and woollen yarn, musical instruments, porcelain, glass, &c., and carries on an extensive trade. Breslau was the seat of a bishopric by the year 1000; an independent duchy from 1163 to 1335; then belonged to Bohemia; and was ceded to Austria in 1527. In 1741 it was conquered by Frederick II. of Prussia. Pop. 1890, 335,174.

**Bres'say**, one of the Shetland Isles, E. of Mainland, from which it is separated by Bressay Sound, about 6 miles long and 1½ in breadth. Its line of coast is rocky and deeply indented; its interior is hilly and largely covered with peat-moss. Sea-fishing is the principal occupation, kelp and hosiery are manufactured, and quarries of coarse slate are wrought. Pop. 1768.

**Brest**, a seaport in the N.W. of France, department of Finisterre. It has one of the best harbours in France, and is the chief station of the French marine, having safe roads capable of containing 500 men-of-war in from 8 to 15 fathoms at low water. The entrance is narrow and rocky, and the coast on both sides is well fortified. The design

to make it a naval arsenal originated with Richelieu, and was carried out by Duquesne and Vauban in the reign of Louis XIV., with the result that the town was made almost impregnable. Brest stands on the summit and sides of a projecting ridge, many of the streets being exceedingly steep. Several of the docks have been cut in the solid rock, and a breakwater extends far into the roadstead. The manufactures of Brest are inconsiderable, but it has an extensive trade in cereals, wine, brandy, sardines, mackerel, and colonial goods. It is connected with America by a cable terminating near Duxbury, Mass.

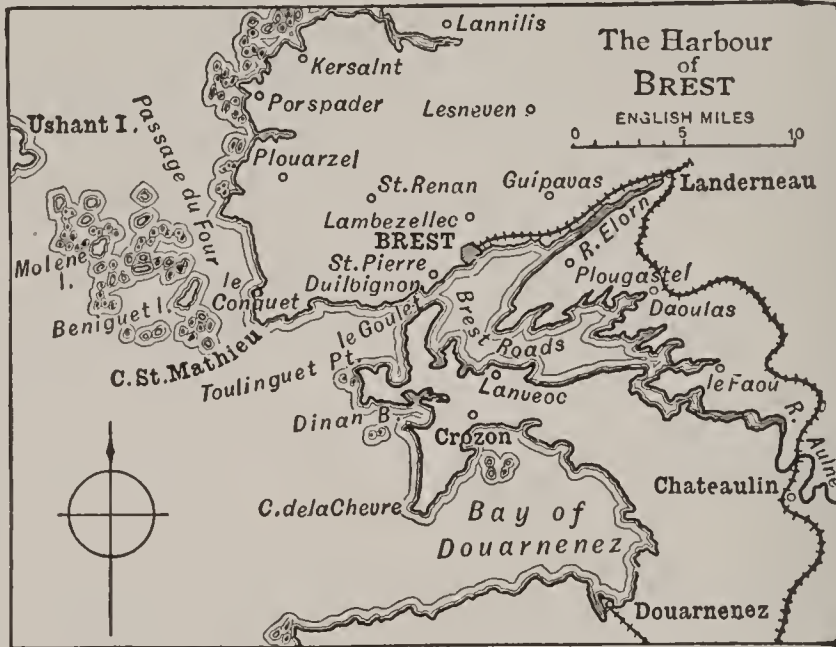

The English and Dutch were repulsed at Brest in 1694. In 1794 it was blockaded by Howe, who won a great victory off the coast over the French fleet. Pop. 75,854.

**Brest-Litowski**, a fortified town of Russia, prov. of Grodno, on the Bug, an important railway centre, and with a large trade. Pop. 35,424.

**Brest-summer**, **BREAST-SUMMER**, or **BRES-SOMER**, in building, a beam or summer placed horizontally to support an upper wall or partition, as the beam over shop windows; a lintel.

**Bretagno** (brè-tân-yè). See *Brittany*.

**Bretèche**, **BRETESCHE** (brâ-tesh'), a name common to several wooden, crenellated, and roofed erections, used in the middle ages in sieges by the assailants to afford protection while they were undermining the walls, and by the besieged to form defences behind breaches. Later, the name was given to a sort of roofed wooden balcony or cage, crenellated and machicolated, attached by corbels, sometimes immediately over a gateway.

**Bretigny** (brè-tên-yè), a village of France, dep. Eure-et-Loire. By the treaty of Bretigny (8th of May, 1360), between Edward III. of England and John II. of France, the latter, who had been taken prisoner at

Poitiers, recovered his liberty on a ransom of 3,000,000 crowns, while Edward renounced his claim to the crown of France, and relinquished Anjou and Maine, and the greater part of Normandy, in return for Aquitaine, Gascony, Poitou, Saintonge, Périgord, Limousin, &c.

**Breton de Los Herreros** (bre-ton' de los er-er'òs), **DON MANUEL**, a popular Spanish poet, born in 1800, died in 1873. He furnished the Spanish stage with more than 150 pieces, original and adapted, besides writing lyrical and satirical poems, &c.

**Bret'ons**, the inhabitants of Brittany.



**Bretts and Scots**, **LAWS**

**OF**, the name given in the 13th century to a code of laws in use among the Celtic tribes in Scotland, the Scots being the Celts north of the Forth and Clyde, and the Bretts being the remains of the British inhabitants of the kingdom of Cambria, Cumbria, or Strathclyde, and Reged. Edward I. issued in 1305 an ordinance abolishing the usages of the Scots and Bretts. Only a fragment of them has been preserved.

**Bretwal'da**, a title applied to one of the Anglo-Saxon tribe-chiefs or kings, who it is supposed was from time to time chosen by the other chiefs, nobility, and ealdormen to be a sort of dictator in their wars with the Britons.

**Breughel** (breu'hel), the name of a celebrated Dutch family of painters, the first of whom adopted this name from a village not far from Breda. This was Pieter Breughel (16th century), also called, from the character and subject of most of his representations, the Droll or the Peasants' Breughel. He left two sons—Pieter and Jan. The former (1565–1625) is commonly known as the Younger Breughel, though he also obtained the name of Hell Breughel, from the many scenes painted by him in which devils and witches appear. His Orpheus playing on his Lyre before the Infernal Deities; and

Temptation of St. Anthony are specially noteworthy in the history of grotesque art. The former picture hangs in the gallery of Florence. The second brother, Jan (1568–1625), known as Velvet Breughel, or Flower Breughel, was distinguished for his landscapes and small figures. He also painted in co-operation with other masters, his Four Elements and other pictures being the joint work of Rubens and himself. Later members of this family are Ambrose, director of the Antwerp Academy of Painting between 1635 and 1670; Abraham, who for a time resided in Italy, and died in 1690; the brother of the latter, John Baptist, who died in Rome; and Abraham's son, Caspar Breughel, known as a painter of flowers and fruits.

**Breve** (brêv), in music, a note formerly square, as ; but now of an oval shape, with a line perpendicular to the stave on each of its sides: . For nearly two centuries it was the musical unit of duration, but has since been supplanted by the semibreve, the breve being of comparatively rare occurrence.

**Brevet'**, in Britain and the U. States applied to a commission to an officer, entitling him to a rank in the army higher than that which he holds in his regiment, without, however, conferring the right to a corresponding advance of pay.

**Brev'iary**, the book which contains prayers or offices to be used at the seven canonical hours of matins, prime, tierce, sext, nones, vespers, and compline by all in the orders of the Church of Rome or in the enjoyment of any R. Catholic benefice. It is not known at what time the use of the breviary was first enjoined, but the early offices were exhaustive from their great length, and under Gregory VII. (1073–85) their abridgment was considered necessary, hence the origin of the breviary (Lat. *brevis*, short). In 1568 Pius V. published that which has remained, with few modifications, to the present day. The Roman breviary, however, was never fully accepted by the Gallican Church until after the strenuous efforts made by the Ultramontanes from 1840 to 1864. The Psalms occupy a large place in the breviary; passages from the Old and New Testament and from the fathers have the next place. All the services are in Latin, and their arrangement is very complex. The English Book of Common Prayer is based on the Roman Breviary.

**Brevier** (bre-vēr'), a kind of printing type, in size between bourgeois and minion, the same as the type of this book.

**Brevipenna'tæ**, a name sometimes given to a short-winged division of Natatores, or swimming-birds. It includes the penguins, auks, guillemots, divers, and grebes.

**Brevipenn'es**, in Cuvier's classification the first family of his order Grallæ, or wading-birds, and equivalent to the order Cursores or section Ratitæ of other naturalists. The ostrich, emu, cassowary, dodo, &c., belong to this tribe.

**Brewing**, the process of extracting a saccharine solution from malted grain and converting the solution into a fermented and sound alcoholic beverage called *ale* or *beer*. The preliminary process of *malting* (often a distinct business to that of brewing) consists in promoting the germination of the grain for the sake of the saccharine matter into which the starch of the seed is thus converted. The barley or other grain is steeped for about two days in a cistern and then piled in a heap, or *couch*, which is turned and re-turned until the radicle or root, and acrospire or rudimentary stem, have uniformly developed to some little extent in all the heap of grain. This treatment lasts from seven to ten days, by which time the grain has acquired a sweet taste; the life of the grain being then destroyed by spreading the whole upon the floor of a kiln to be thoroughly dried. At this point begins the brewing process proper, which in breweries is generally as follows: The malt is crushed or roughly ground in a malt-mill, whence it is carried to the mashing-machine, and there thoroughly mixed with hot water. The mixture is now received by the mash-tun—a cylindrical vessel with a false perforated bottom held about an inch from the true one. In the mash-tun the useful elements are extracted from the malt in the form of the sweet liquor known as wort, and the tun, therefore, is fitted with an elaborate system of revolving rakes for thoroughly mixing the malt with hot water. The mixing completed, the mash-tun is covered up and allowed to stand for about three hours, when the taps in the true bottom are opened and the wort or malt-extract run off. The wort being drained into a copper the hops are now added, and the whole boiled for about two hours, the boiling, like the addition of hops, tending to prevent acetous and putrefactive fermentation. When sufficiently boiled the contents of the

copper are run into the hop-back—a long, rectangular vessel with a false bottom 8 or 9 inches from the true bottom. The hot wort leaving the spent hops in the hop-back runs through the perforations in the false bottom and thence into the cooler—a large flat vessel where the worts are cooled to about 100° Fah. From the cooler the liquor is admitted to the refrigerator—a shallow rectangular vessel, which reduces the temperature to almost that of the cold water, or about 58°. The worts are next led by pipes into the large wooden fermenting tuns, where yeast or barm is added as soon as the wort begins to run in from the refrigerator. During the operation of fermentation, by which a portion of the saccharine matter is converted into alcohol, the temperature rises considerably, and requires to be kept in check by means of a coil of copper piping with cold water running through it lowered into the beer. When the fermentation has gone far enough, and the liquor has been allowed to settle, the beer becomes comparatively clear and bright, and may be run off and filled into the trade casks or into vats.

The various beers manufactured from grain have sometimes been classified under the three heads of *beer*, *ale*, and *porter*; but at the present day this classification will not hold, as *beer*, though it occasionally may have a specific meaning, is often used as the general name for all malt liquors. Both terms belong to the early or Anglo-Saxon period of the English language, but in more modern times the term *beer* seems to have been applied more especially to malt liquor flavoured with hops, wormwood, or other bitters. Ale was originally made from barley malt and yeast alone, and the use of hops was first introduced in Germany, which is still a great brewing country. One of the kinds of German beer now widely known and consumed is *lager beer*—that is, *store beer*, the name being given to it because it is usually kept for four to six months before being used. In brewing it the fermentation is made to go on rather slowly and at a low temperature. Much lager beer is now made in America. Among the most celebrated beers are the English pale ales brewed at Burton-on-Trent. The excellence of the Burton ale depends partly on the water used, which is all drawn from wells, and contains carbonates and sulphates of lime and magnesia in large quantities, and partly on the method of brewing. The English bitter beer made for home consumption is

less bitter than that which is sent abroad, at least as brewed by the best brewers; but a good part of the beer sold under this name is of poor quality and would have little flavour were it not for the hops. Porter, which is very largely made in London, as also in Dublin, is of a very dark colour, this colour being obtained by the use of a certain proportion of malt subjected to a heat sufficient to scorch or blacken it.

The manufacture of ale or beer is of very high antiquity. Herodotus ascribes the invention of brewing to Isis, and it was certainly practised in Egypt. Xenophon mentions it as being used in Armenia, and the Gauls were early acquainted with it. Pliny mentions an intoxicating liquor made of corn and water as common to all the nations of the west of Europe, and in England ale-booths were regulated by law as early as the 8th century. A rude process of brewing is carried on by many uncivilized races; thus *chica* or maize beer is made by the South American Indians, millet beer by various African tribes, &c.

**Brewster**, SIR DAVID, natural philosopher, born at Jedburgh 1781; studied at Edinburgh University for the church, but was attracted by the lectures of Robison and Playfair to science. In 1807 he was an unsuccessful candidate for the mathematical chair at St. Andrews, but became in the same year M.A. of Cambridge, LL.D. of Aberdeen, and member of the Royal Society of Edinburgh, to the Transactions of which he contributed important papers on the polarization of light. In 1808 he became editor of the Edinburgh Encyclopædia, and in 1819, in conjunction with Jameson, founded the Edinburgh Philosophical Journal, of which he was sole editor from 1824–32. Brewster was one of the founders of the British Association, and its president in 1850. In 1832 he was knighted and pensioned, and both before and after this time his services to science obtained throughout Europe the most honourable recognition. From 1838 to 1859 he was principal of the united colleges of St. Leonard's and St. Salvador at St. Andrews, and in the latter year was chosen principal of the University of Edinburgh—an office which he held till his death in 1868. Among his inventions were the 'polyzonal lens' (introduced into British lighthouses in 1835), the kaleidoscope, and the improved stereoscope. His chief works are a Treatise on the Kaleidoscope (1829); Letters on Natural Magic

(1831); Treatise on Optics (1831); More Worlds than One (1854); and Lives of Euler, Newton, Galileo, Tycho Brahe, and Kepler.

**Brialmont** (brē-āl-mōn), HENRI ALEXIS, Belgian military writer, born in 1821, entered the army in 1843 as lieutenant of engineers, now lieutenant-general. Among his works are *Considérations Politiques et Militaires sur la Belgique*; *Précis d'Art Militaire*; *Histoire du Duc de Wellington*, translated into English by Gleig; *Étude sur la Défense des États et sur la Fortification*; and many works on fortification.

**Bri'an** (surnamed *Boroimhé* or *Boru*), a famous chieftain of the early Irish annals, who succeeded to Munster in 978, defeated the Danes of Limerick and Waterford, attacked Malachi, nominal king of the whole island, and became king in his stead (1002). He was slain at the close of the battle of Clontarf, near Dublin, in 1014, after gaining a signal victory over the revolted Maelmora and his Danish allies.

**Briançon** (brē-ān-sōn; ancient *Brigentium*), a town and fortress of France, department of Hautes Alpes, on the right bank of the Durance. It occupies an eminence 4284 ft. above sea-level, and has been called the Gibraltar of the Alps. Pop. 3579.

**Briansk'**, a town, Russia, government of Orel, on the Desna, with a considerable trade, and near it are a cannon-foundry and a manufactory of small-arms. Pop. 13,881.

**Briar**, BRIER, the wild rose. The well-known *briar-root* tobacco-pipes are made from the root of a large kind of heath (Fr. *bruyère*, heath), a native of S. Europe, Corsica, Sardinia, Algeria, &c.

**Briareus** (brī-ā'rūs), in Greek fable, a giant with 100 arms and 50 heads, aided Jupiter (Zeus) in the war with the Titans.

**Bribe**, a reward given to a public officer or functionary to induce him to violate his official duty so as to suit the person bribing;

especially a corrupt payment of money for the votes of electors in the choice of persons to places of trust under government. Bribery is in most countries regarded as a crime deserving severe punishment. In Britain acts amending and consolidating previous acts against bribery at elections were passed in 1854 and in 1868, when it was enacted that election petitions should be tried by a specially constituted court. Bribery at municipal elections was dealt with by an act passed in 1872, in which year the passing of the ballot act introduced a new safeguard. Flagrant cases, however, occurring at the elections of 1880, new and more stringent acts against bribery were passed in the years 1881 and 1883. Similar statutory provisions have been

enacted in the United States.

**Brick**, a sort of artificial stone, made principally of argillaceous earth formed in moulds, dried in the sun, and baked by burning, or, as in many Eastern countries, by exposure to the sun. Sun-dried bricks of great



Briançon.

antiquity have been found in Egypt, Assyria, and Babylonia, and in the mud walls of old Indian towns. Under the Romans the art of making and building with bricks was brought to great perfection, and the impressions on Roman bricks, like those on the bricks of Babylonia, have been of considerable historic value. The Roman brick was afterwards superseded in England by the smaller Flemish make. Of the various clays used in brickmaking, the simplest, consisting chiefly of silicates of alumina, are almost infusible, and are known as fire-clays, the Stourbridge clay being specially famous. Of such clays fire-bricks are made. Clays containing lime and no iron burn white, the colours of others being due to the presence in varying proportions of ferric oxide, which also adds to the hardness of bricks. The clay should be dug in autumn and exposed to the influence of frost and rain. It

should be worked over repeatedly with the spade and tempered to a ductile homogeneous paste, and should not be made into bricks until the ensuing spring. The making of bricks by hand in moulds is a simple process. After being made and dried for about nine or ten days they are ready for the burning, for which purpose they are formed into *kilns*, having flues or cavities at the bottom for the insertion of the fuel, and interstices between them for the fire and hot air to penetrate. Much care is necessary in regulating the fire, since too much heat vitrifies the bricks and too little leaves them soft and friable. Bricks are now largely made by machines of various construction. In one the clay is mixed and comminuted in a cylindrical pug-mill by means of rotatory knives or cutters working spirally and pressing the clay down to the bottom of the cylinder. From this it is conveyed by rollers and forced through an opening of the required size in a solid rectangular stream, which is cut into bricks by wires working transversely. Machine-made bricks are heavier, being less porous than hand-made bricks, and are more liable to crack in drying; but they are smoother, and, when carefully dried, stronger than the hand-made.

**Bridewell**, in Blackfriars, London, formerly used as a house of correction. The building, of which only the hall, treasurer's house, and offices remain, takes its name from a well once existing between Fleet Street and the Thames, and dedicated to St. Bride. Henry VIII. built on this site, in 1522, a palace for the accommodation of the Emperor Charles V., which was afterwards converted by Edward VI. into an hospital to serve as a workhouse for the poor and a house of correction for the idle and vicious.

**Bridge**, a structure of stone, brick, wood, or iron, affording a passage over a stream, valley, or the like. The earliest bridges were no doubt trunks of trees. The arch seems to have been unknown amongst most of the nations of antiquity. Even the Greeks had not sufficient acquaintance with it to apply it to bridge building. The Romans were the first to employ the principle of the arch in this direction, and after the construction of such a work as the great arched sewer at Rome, the *Cloaca Maxima*, a bridge over the Tiber would be of comparatively easy execution. One of the finest examples of the Roman bridge was the bridge built by Augustus over the Nera at Narni, the vestiges of which still remain. It consisted of four

arches, the longest of 142 feet span. The most celebrated bridges of ancient Rome were not generally, however, distinguished by the extraordinary size of their arches, nor by the lightness of their piers, but by their excellence and durability. The span of their arches seldom exceeded 70 or 80 feet, and they were mostly semicircular, or nearly so. The Romans built bridges wherever their conquests extended, and in Britain there are still a number of bridges dating from Roman times. One of the most ancient post-Roman bridges in England is the Gothic triangular bridge at Croyland, in Lincolnshire, said to have been built in 860, having three archways meeting in a common centre at their apex, and three roadways. The longest old bridge in England was that over the Trent at Burton, in Staffordshire, built in the twelfth century, of squared free-stone, and recently pulled down. It consisted of thirty-six arches, and was 1545 feet long. Old London Bridge was commenced in 1176, and finished in 1209. It had houses on each side like a regular street till 1756-58. In 1831 it was altogether removed, the new bridge, which had been begun in 1824, having then been finished. The art of bridge-building made no progress after the destruction of the Roman empire till the eighteenth century, when the French architects began to introduce improvements, and the constructions of Perronet (Nogent-sur-Seine; Neuilly; Louis XVI. bridge at Paris) are masterpieces. Within the last half-century or so the use of steam and iron, the immense development of all mechanical contrivances, and the great demand for railway bridges and viaducts have given a great stimulus to invention in this department.

Stone bridges consist of an arch or series of arches, and in building them the properties of the arch, the nature of the materials, and many other matters have to be carefully considered. It has been found that in the construction of an arch the slipping of the stones upon one another is prevented by their mutual pressure and the friction of their surfaces; the use of cement is thus subordinate to the principle of construction in contributing to the strength and maintenance of the fabric. The masonry or rock which receives the lateral thrust of an arch is called the *abutment*, the perpendicular supports are the *piers*. The width of an arch is its *span*; the greatest span in any stone bridge is about 250 feet. A one-span bridge has, of course, no piers. In constructing a

## BRIDGE.

bridge across a deep stream it is desirable to have the smallest possible number of points of support. Piers in the waterway are not only expensive to form, but obstruct the navigation of the river, and by the very extent of resisting surface they expose the structure to shocks and the wearing action of the water. In building an arch, a timber framework is used called the *centre*, or *centering*. The *centering* has to keep the stones or *voussoirs* in position till they are keyed in, that is, all fixed in their places by the insertion of the key-stone.

The first iron bridges were erected from about 1777 to 1790. The same general principles apply to the construction of iron as of stone bridges, but the greater cohesion and adaptability of the material give more liberty to the architect, and much greater width of span is possible. At first iron bridges were erected in the form of arches, and the material employed was cast-iron; but the arch

has now been generally superseded by the beam or *girder*, with its numerous modifications; and wrought-iron or steel is likewise found to be much better adapted for resisting a great tensile strain than cast-metal. Numerous modifications exist of the beam or girder, as the *lattice-girder*, *bow-string-girder*, &c.; but of these none is more interesting than the *tubular* or hollow

girder, first rendered famous from its employment by Robert Stephenson in the construction of the railway bridge across the Menai Strait, and connecting Anglesey with the mainland of North Wales. This is

known as the Britannia Tubular Bridge. The tubes are of a rectangular form, and constructed of riveted plates of wrought-iron, with rows of rectangular tubes or cells for the floor and roof respectively. The bridge consists of two of these enormous tubes or hollow beams laid side by side, one for the up and the other for the down traffic of the railway, and extending each to about a quarter of a mile in length. Other tubular bridges of importance are the Conway Bridge, over the river Conway, an erection identical in principle with the Britannia Bridge, but on a smaller scale; the Brotherton Bridge over the river Aire; the tubular railway bridge across the Dami-  
etta branch of

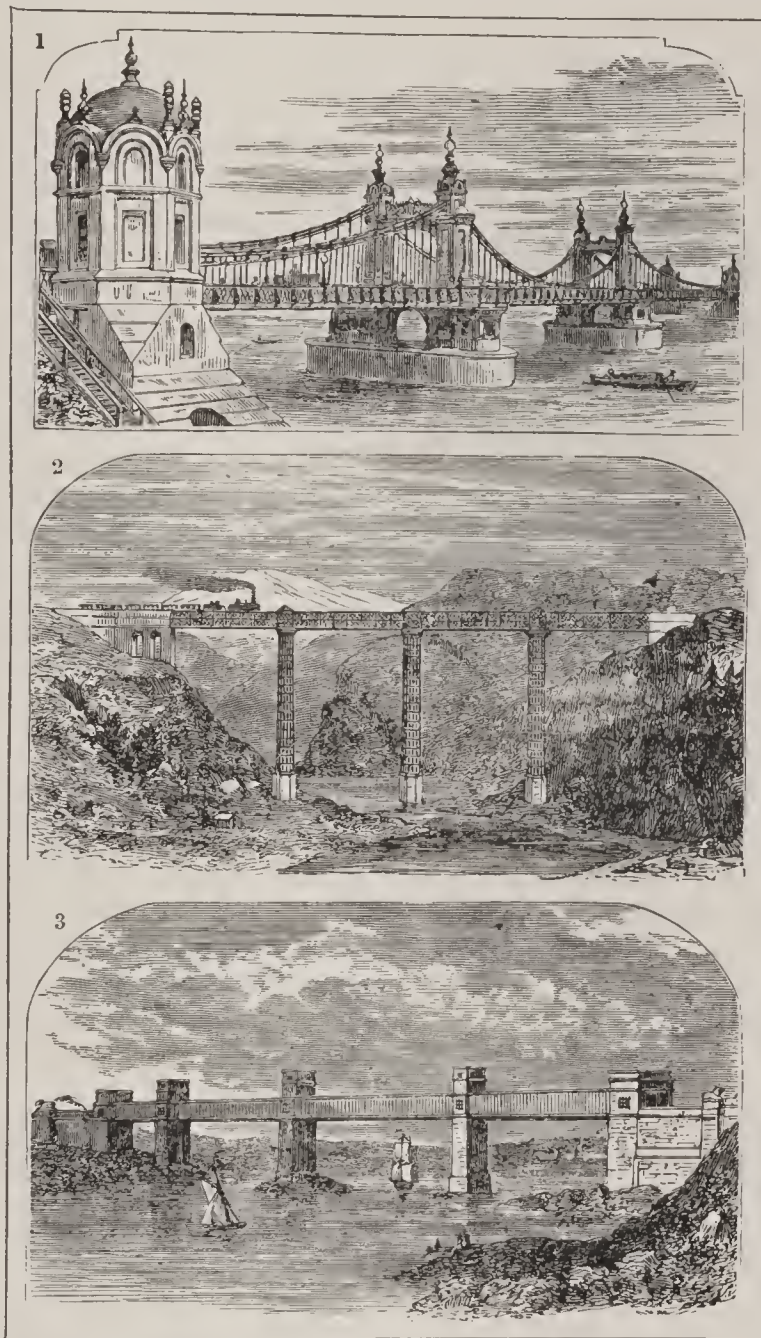

1, Suspension-bridge, Chelsea.  
2, Lattice Bridge on Railway from St. Gall to Appenzell.  
3, The Britannia Tubular Bridge.

the Nile, which has this peculiarity, that the roadway is carried *above* instead of *through* the tubes; and the Victoria Bridge over the St. Lawrence, Canada. In many respects this structure is even more remarkable than the Britannia Bridge, being supported by twenty-four piers, and nearly 2 miles in length, or about five and a half times that of the bridge across the Menai Strait. A girder railway bridge across the Firth of Tay at

Dundee was opened in 1887, being the second built at the same place, after the first had given way in a great storm. It is 2 miles 73 yds. long, has 85 spans, is 77 ft. high, and carries two lines of rails. The bridge over the Firth of Forth, at Queensferry, in course of construction, has two chief spans of 1710 feet, two others of 680 feet, fifteen of 168 feet, and seven small arches, and will give a clear headway for navigation purposes of 150 feet above high-water of spring-tides. The great spans consist of a cantilever at either end, 680 feet long, and a central girder of 350 feet. Both the above bridges are built to carry the lines of the North British Railway. The Crumlin Railway Viaduct, South Wales, having lattice-girders supported on open-work piers is more remarkable for height than length, being 200 feet high.

Suspension-bridges, being entirely independent of central supports, do not interfere with the river, and may be erected where it is impracticable to build bridges of any other kind. The entire weight of a suspension-bridge rests upon the piers at either end from which it is suspended, all the weight being below the points of support. Such bridges always swing a little, giving a vibratory movement which imparts a peculiar sensation to the passenger. The modes of constructing these bridges are various. The roadway is suspended either from chains or from wire-ropes, the ends of which require to be *anchored*, that is attached to the solid rock or masses of masonry or iron. One of the earlier of the great suspension-bridges is that constructed by Telford over the Menai Strait near the Britannia Tubular Bridge, finished in 1825; the opening between the points of suspension is 580 feet. The Hammersmith Chain-bridge, the Union Suspension-bridge near Berwick, and the suspension-bridge over the Avon at Clifton are other British examples. On the European continent, the Fribourg Suspension-bridge in Switzerland, span 870 feet, erected 1834, is a celebrated work; as is that over the Danube connecting Buda with Pesth. In America the lower suspension-bridge over the Niagara, 7 miles below the falls, supported by wire cables, is 822 feet long; it has two floors or roadways connected together but 15 feet apart, the lower serving for ordinary traffic, the upper carrying three lines of rails, 245 feet above the river. Another bridge, close to the falls, has a span

of 1250 feet. The Cincinnati bridge over the Ohio has a span of 1057 feet. A suspension-bridge of great magnitude, connecting the city of New York with Brooklyn, was opened in 1883. The central or main span is 1595½ feet from tower to tower, and the land spans between the towers and the anchorages 930 feet each; the approach on the New York side is 2492 feet long, and that on the Brooklyn side 1901 feet, making the total length 5989 feet. The height of the platform at the centre is 135 feet above high water, and at the ends 119 feet. The roadway is 85 feet broad, and is divided into five sections, the two outside for vehicles, the two inner for tram-cars, and the middle one, 12 feet above the rest, for foot-passengers. Cost over \$15,000,000.

Though the oldest bridges on record were built of wood, like the Sublician Bridge at Rome, or that thrown by Cæsar across the Rhine, it is only in certain places and for certain purposes that wood is much used at present. In modern times Germany has been the school for wooden bridges. Perhaps the most celebrated of all wooden bridges was that which spanned the Rhine at Schaffhausen in Switzerland. This was 364 feet in length and 18 feet broad. It was designed and executed by Ulric Grubenman, a village carpenter, in 1758, and was destroyed by the French in 1799. In the United States, where timber is still in common use, we have some fine examples, the Trenton Bridge over the Delaware, erected in 1804; the bridge over the Susquehannah, &c. Some of the most notable developments in the art of bridge construction are to be found in North America, where an enormous railway system, traversing a country of great rivers and ravines, has given an exceptional stimulus to the art. The main characteristics of American bridges are simplicity and boldness of design, the reduction of the number of members to a minimum by the use of open trusses composed of simple systems rather than the plate, tubular, or closely-latticed girders of European engineers, thus offering less resistance to wind pressure.

**Bridgeman**, LAURA, a blind deaf-mute, born in Hanover, New Hampshire, in 1829. Till the age of two years she was a bright active child, when a severe illness deprived her of the senses of sight, hearing, and smell, and partly also of that of taste. She was put under the care of Dr. Howe of Boston, and the history of the methods by



which she was gradually taught to read, write, and eventually perform most of the ordinary duties and even some of the accomplishments of life, is a very interesting one. She became herself a teacher of persons similarly afflicted, and has led an active and useful life.

**Bridge'north**, or BRIDGNORTH, a town, England, Shropshire, 19 miles s.e. from Shrewsbury, on the Severn, which divides it into two portions, called the High Town and the Low Town, connected by a handsome bridge of six arches. The principal manufacture is carpeting and worsteds. Pop. 1891, 5723.

**Bridge of Allan**, a town of Scotland, in Stirlingshire, partly in Perthshire, on the Allan; a favourite resort for invalids on account of its exceptionally mild climate. There are mineral wells and a hydropathic establishment. Pop. 3004.

**Bridge'port**, a seaport of Connecticut, U.S., 58 miles n.e. of New York, on an arm of Long Island Sound, with a large coasting trade, but chiefly supported by its manufactures, including the large sewing-machine factories of Wheeler, Wilson, & Co., Elias Howe, &c. Pop. 48,856.

**Bridget**, the name of two saints in the Roman Catholic Church.—The first, better known as ST. BRIDE, was born in Ireland about the end of the 5th century. She was exceedingly beautiful, and to avoid offers of marriage and other temptations implored God to render her ugly, which prayer was granted. An order of nuns of St. Bride was established, which continued to flourish for centuries. St. Bride was held in great reverence in Scotland.—The second ST. BRIDGET, or more properly Birgit or Brigitte, was the daughter of a Swedish prince, born about 1302, and died at Rome in 1373, on her return from a pilgrimage to Palestine. She left a series of mystic writings which were pronounced inspired by Gregory XI. and Urban VI. Her youngest daughter, Catherine, was also canonized, and became the patron saint of Sweden.

**Bridge'ton**, a port of entry in New Jersey, U.S., situated on both sides of Cohansay Creek, 20 miles above its entrance into Delaware Bay. Pop. 11,424.

**Bridgetown**, the capital of the island of Barbados, in the West Indies, extending along the shore of Carlisle Bay, on the s.w. coast of the island, for nearly 2 miles. Its appearance is very pleasing, the houses being embosomed in trees, while hills of moderate

height rise behind, studded with villas. Bridgetown is the residence of the governor-general of the Windward Islands. Pop. 20,947.

**Bridge'water**, or BRIDGWATER, a municipal borough and port in the county of Somerset, England, on the Parret, which is navigable as far up as the town for small vessels. A considerable shipping trade is carried on, chiefly coastwise. Bricks are made here in great quantities, especially bath-bricks. Up till 1870, when it was disfranchised for bribery, Bridgewater returned two members to parliament. Pop. 12,429.

**Bridgewater**, a town of Nova Scotia, 50 miles south-west of Halifax. Pop. 3500.

**Bridgewater**, FRANCIS EGERTON, DUKE OF, English nobleman, born in 1736. His estate of Worsley contained valuable coal-mines, and with the view of establishing a communication between these and the town of Manchester, at 7 miles' distance, he employed Brindley to construct a navigable canal, which, after having encountered much opposition and ridicule, was triumphantly carried through. He was the chief promoter of other excellent works of the same kind. He died in 1803. See *Brindley*.

**Bridgewater Treatises**, a series of books, the outcome of the will of the Rev. Henry Francis, Earl of Bridgewater, who died in 1829, bequeathing a sum of £8000, which should be paid to the person or persons chosen to write and publish 1000 copies of a work on the power, wisdom, and goodness of God as manifested in the creation. The result was eight works on animal and vegetable physiology, astronomy, geology, the history, habits, and instincts of animals, &c., which at one time enjoyed great popularity. The names of the writers are Dr. Chalmers, Dr. Kidd, Dr. Whewell, Sir Charles Bell, Dr. Roget, Dr. Buckland, Rev. William Kirby, and Dr. Prout.

**Bridle**, the head-stall, bit, and reins by which a horse is governed.

**Brid'lington**, or BURLINGTON, a town of Yorkshire, England, agreeably situated about a mile from the sea, 37 miles n.e. from York, with a considerable trade. Pop. 8916. Half a mile from Bridlington is *Bridlington Quay*, a favourite sea-bathing resort, and having also mineral waters resembling those of Scarborough and Cheltenham.

**Brid'port**, a seaport in Dorsetshire, England, between the rivers Bride or Brit and Asker, which unite a little below the town,

and form a safe and commodious harbour for small vessels. There are manufactures of shoe-thread, twine, lines, sail-cloth, fishing-nets, &c. Pop. 1891, 6611.

**Brief**, which comes from the Latin *brevis*, short, denotes a brief or short statement or summary, particularly the summary of a client's case which the solicitor draws up for the instruction of counsel. A brief may also mean, in law, an order emanating from the superior courts. A *papal brief* is a sort of pastoral letter in which the pope gives his decision on some matter which concerns the party to whom it is addressed. The brief is an official document, but of a less public character than the bull.

**Brieg** (*brēh*), a town, Prussia, province of Silesia, on the left bank of the Oder, which is here crossed by a long wooden bridge, 26 miles S.E. from Breslau, with a considerable transit trade and some manufactures, chiefly linens, woollens, cottons, leather, &c. Pop. 17,503.

**Briel** (*brēl*), or **BRIELLE** (*brē-el'*), sometimes called the *Brill*, a fortified seaport of Holland, near the mouth of the Maas, province of South Holland. The taking of Briel in 1572 was the first success of the revolted Netherlanders in their struggle with Philip II. of Spain. The famous Admiral Van Tromp was born here. Pop. 1442.

**Brienne** (*brē-ān*), a small town of France, dep. Aube. In the military academy which formerly existed here Napoleon received his early military training. Brienne was also the scene of a bloody battle between Blücher and Napoleon (29th Feb. 1814).

**Brienne, JOHN OF**, a celebrated Crusader, born 1148, died 1237; was son of Erard II., count of Brienne; was present at the siege of Constantinople in 1204, and afterwards, in 1209, married the granddaughter and heiress of Amaury, king of Jerusalem. Brienne thus obtained an empty title which he afterwards ceded to the Emperor Frederick II. Later on he was again formally associated with Baldwin II. as joint emperor of the Latin empire in the East. After a series of heroic exploits in defence of his dominions, in 1237 he resigned his crown to retire into a monastery, where he died.

**Brienz** (*brē'ents*), a town, Switzerland, canton Bern, beautifully situated on the N.E. shore of the Lake of Brienz. It is notable for its wood-carving. Pop. 2758.

**Brier.** See *Briar*.

**Bri'erly Hill**, a town in Staffordshire, England, on the Stour. In lies in a rich min-

eral district, and carries on considerable industry in coal-mines, brick-works, iron-works, &c. Pop. 1891, 11,831.

**Brieuc, St.** (*san brē-cu*), a seaport town, France, dep. Côtes du Nord, about a mile above the mouth of the Gouët. It is the seat of a bishop and has a very ancient cathedral. It manufactures cottons, woollen stuffs, paper, &c. Pop. 17,833.

**Brig**, a sailing vessel with two masts



Brig.

rigged like the foremast and mizzen-mast of a full-rigged ship.

**Brigade.** In the U. S. army four regiments of infantry or cavalry usually constitute a brigade, commanded by a brigadier-general. A number of brigades form a division; several divisions an army corps.

**Briggs, CHARLES A.**, Professor, was born in New York city, Jan. 15, 1841. He was appointed professor of Hebrew in Union Theological Seminary, New York city, in 1874. In 1890 he was transferred to the Edward Robinson professorship of Biblical Theology. His inaugural address on 'The Authority of the Scriptures' contained views disapproved of by the General Assembly in 1891. He was acquitted of heresy by the Presbytery of New York in 1892; on appeal to the General Assembly in 1893 Dr. Briggs was convicted of teaching contrary to the Presbyterian standards, and suspended from the ministry until he retracts. He taught that the Bible contains errors in statements of historical facts, in numbers, &c., but in regard to spiritual truths it is to be accepted as infallible; divine truth has three sources—the Bible, the

church, and reason; salvation may be attained without knowledge of the Bible; also a progressive sanctification after death.

**Bright, JOHN**, a great English orator and politician, born at Greenbank, near Rochdale, Lancashire, Nov. 16, 1811. His father, Mr. Jacob Bright, carried on a cotton-spinning and manufacturing business of which the son became the head. He first became known as a leading spirit along with Mr. Cobden in the Anti-Corn-Law League. In 1843 he was chosen M.P. for Durham, and distinguished himself as a strenuous advocate of free-trade and reform. In 1847 he sat for the first time for Manchester, but in 1857 his opposition to the war with China made him so unpopular in the constituency that he lost his seat by a large majority. He was, however, returned for Birmingham, and soon after made speeches against the policy of great military establishments and wars of annexation. In 1865 he took a leading part in the movement for the extension of the franchise, and strongly advocated the necessity of reform in Ireland. In the Gladstone ministry formed in 1868 he was President of the Board of Trade and afterwards Chancellor of the Duchy of Lancaster, and he held the latter office again under Mr. Gladstone in 1880–82. In 1886 he joined the Liberals who opposed Mr. Gladstone's schemes for Ireland, and contributed by his letters and influence to the overthrow of the Gladstone party. He was a member of the Society of Friends. He died March 27, 1889.

**Brighton** (brī'tun; formerly *Bright-helm-stone*), a maritime town and favourite watering-place in England, county of Sussex, 50½ miles from London. It is situated on a gentle slope, protected from the north winds by the high ground of the South-Downs immediately behind the town, and is well built, with handsome streets, terraces, squares, &c. In front of the town is a massive sea-wall, with a promenade and drive over 3 miles in length, one of the finest in Europe. Amongst the remarkable buildings, all of modern date, is the Pavilion, built by George IV., which cost upwards of £1,000,000. It is in the oriental style, with numerous cupolas, spires, &c. The building and its gardens, which are open to the public as pleasure-grounds, cover about 9 acres. There is a very large and complete aquarium, and a fine iron pier. Brighton has no manufactures, and is resorted to only as a watering-place. It was about the middle of last century that Dr. Russell, an eminent physician, drew atten-

tion to Brighton, which subsequently was patronized by George IV., then Prince of Wales; in this way it was converted from a decayed fishing village into a fashionable and populous watering-place. It has sent two members to parliament since 1832. The pop. in 1801 was only 7339; in 1891 it was 115,402 within the municipal boundaries, and 142,121 within the parliamentary.



John Bright.

**Bright's Disease**, a name (derived from a Dr. Bright of London, who first described the disorder) given to various forms of kidney disease, especially to that which is characterized by a granular condition of the cortical part of the kidneys and inflammation of the malpighian bodies. The urine during life contains albumen, and is of less specific gravity than natural. The disease is accompanied with uneasiness or pain in the loins, pale or cachectic countenance, disordered digestion, frequent urination, and dropsy. The blood contains urea, and is deficient in albumen and corpuscles. Progressive blood-poisoning induces other visceral diseases, and in the end gives rise to the cerebral disturbance which is the frequent cause of death.

**Brignoles** (brin-yōl), a town in Southern France, dep. Var, in a fertile valley celebrated for its salubrity. Pop. 5678.

**Brihuega** (brē-wā'gā), a town of Spain, in New Castile, on the Tajuna. Here in 1710 the allies under Lord Stanhope were defeated by the Duke of Vendôme in the Spanish Succession war. Pop. 4140.

**Bril**, the name of two brothers who distinguished themselves as landscape-painters. —MATTHEW, born at Antwerp in 1550, died

in 1584; repaired when a very young man to Rome, and was employed on the galleries and saloons of the Vatican.—PAUL, born about 1556, died about 1626, and of much superior talent, joined his brother in Rome, and amongst other labours executed a large fresco (his greatest work, 68 feet long) in the Sala Clementina of the Vatican. Paul is memorable as having done much to develop landscape-painting as an independent branch of the art. His best pictures do not fall much short of those of Claude Lorraine, his great successor

**Brill** (*Rhombus vulgāris*), a fish resembling the turbot, but inferior in quality, and distinguished from it by its inferior breadth and by the perfect smoothness of its skin. The brill is of a pale-brown colour above, marked by scattered yellowish or reddish spots. It is abundant in the English Channel, and is esteemed for the table.

**Brillat-Savarin** (bré-yā-sā-vā-ran), a French author, who, although he wrote works on political economy, archaeology, and duelling, is now known only by his famous book on gastronomy, the *Physiologie du Goût*, published in 1825. He was born at Bellay in 1755, and after holding several honourable positions as a magistrate, died in Paris, 1826.

**Brilliant.** See *Diamond*.

**Brim'stone**, a name of sulphur. Sulphur, in order to purify it from foreign matters, is generally melted in a close vessel, allowed to settle, then poured into cylindrical moulds, in which it becomes hard, and is known in commerce as *roll brimstone*.

**Brindaban** (brin-dā-ban'), a town of India, N. W. Provinces, Muttra District, right bank of the Jumna, one of the holiest cities of the Hindus, with a large number of temples, shrines, and sacred sites. Pop. 21,467.

**Brindisi** (brēn'di-sē; anc. *Brundisium*), a seaport and fortified town, province of Lecce, Southern Italy, on the Adriatic, 45 miles E.N.E. of Taranto. In ancient times Brundisium was an important city, and with its excellent port became a considerable naval station of the Romans. Its importance as a seaport declined in the middle ages, and was subsequently completely lost, and its harbour blocked, until in 1870 the Peninsular and Oriental Steam Navigation Company put on a weekly line of steamers between Brindisi and Alexandria for the conveyance of mails and passengers between Europe and the East. From this cause

Brindisi has suddenly risen into importance. Pop. 16,719.

**Brind'ley**, JAMES, an English engineer and mechanic, born in 1716, died in 1772. When the Duke of Bridgewater was occupied in planning a communication between his estate at Worsley and the towns of Manchester and Liverpool by water, Brindley undertook the work, and by means of aqueducts over valleys, rivers, &c., he completed the Bridgewater Canal between 1758 and 1761, so as to form a junction with the Mersey. The other great works of this kind undertaken by him were the Grand Trunk Canal uniting the Trent and Mersey, and a canal uniting that with the Severn.

**Brine**, water saturated with common salt. It is naturally produced in many places beneath the surface of the earth, and is also made artificially, for preserving meat, a little saltpetre being generally added to the solution.

**Brine-shrimp**, a branchiopodous crustacean, the *Artemia salina*, about  $\frac{1}{2}$  inch in length, and commonly found in the brine of salt-pans previous to boiling.

**Brinvilliers** (bran-vēl-yā), MARIE MARGUERITE D'AUBRAY, MARCHIONESS OF, born about 1630, executed 1676. She was married in 1651 to the Marquis of Brinvilliers, but after some seven or eight years of married life a young cavalry officer named Sainte-Croix inspired her with a violent passion, and being instructed by him in the art of preparing poisons, she poisoned in succession her father, her two brothers, and her sisters, chiefly, it is thought, in order to procure the means for living extravagantly with her paramour. The sudden death of Sainte-Croix, caused, it is said, by the falling off of a glass mask which he used to protect himself in preparing poisons, led to the discovery of letters incriminating Madame de Brinvilliers. She fled to England, and finally to Liége, where she was captured, conveyed to Paris, and condemned to death.

**Brio** (brē'ō), an Italian word signifying vivacity, but now much used also in other languages to express a very catching, spirited, or even fiery manner of doing a thing, particularly in reference to artistic execution, as in singing, piano-playing, &c.

**Brisach.** See *Breisach*.

**Brisbane**, the capital of Queensland, about 25 miles by water from the mouth of the river Brisbane, which intersects the town. Brisbane was originally settled, in 1825, as a penal station by Sir Thomas Bris-

bane (whence the name of the town). In 1842 the district was opened to free settlers, and on the erection of Queensland into a separate colony in 1859, Brisbane became the capital. Since then it has made great progress, and now possesses many fine public buildings, such as the Houses of Legislature, erected at a cost of over £100,000, the town-hall and the Albert Hall, the vice-

vatory at Paramatta catalogued 7385 stars, until then scarcely known. On his return to Scotland he continued his astronomical pursuits, and died in 1860.

**Brisgau.** See BREISGAU.

**Brissot** (brē-sō), JEAN PIERRE (also called BRISSOT DE WARVILLE), a French political writer, born in 1754, executed 30th October, 1793. He early turned his attention to public affairs, associating himself with such men as Pétion, Robespierre, Marat, &c. In 1780 he published his *Théories des Lois Criminelles*, and two years afterwards an important collection called the *Bibliothèque des Lois Criminelles*. During the revolution he made himself known as a politician and one of the leaders of the Girondist party. The extreme views of the men of the 'Mountain' having prevailed over more moderate counsels, Brissot, like most of his party, suffered death by the guillotine.

**Bristles**, the stiff, coarse, glossy hairs of the hog and the wild boar, especially of the hair growing on the back; extensively used by brushmakers, shoemakers, saddlers, &c., and chiefly imported from Russia and Germany. Russia supplies the finest qualities, which are worth about £50 or £60 per cwt.

**Bris'tol**, a cathedral city of England, a municipal and a parliamentary borough, situated partly in Gloucestershire, partly in Somersetshire, but forming a county in itself. It stands at the confluence of the rivers Avon and Frome, which unite within the city, whence the combined stream (the Avon) pursues a course of nearly 7 miles to the Bristol Channel. The Avon is a navigable river, and the tides rise in it to a great height. The town is built partly on low grounds, partly on eminences, and has some fine suburban districts, such as Clifton, on the opposite side of the Avon, and connected with Bristol by a suspension-bridge 703 feet long and 245 feet above high-water mark. The public buildings are numerous and handsome, and the number of places of worship very great. The most notable of these are the cathedral, founded in 1142, exhibiting various styles of architecture, and recently restored and enlarged; St. Mary Redcliff, said to have been founded in 1293, and perhaps the finest parish church in the kingdom. Among modern buildings are the exchange, the guild-hall, the council-house, the post-office, the new grammar-school, the fine arts academy, the West of England and other banks, insurance offices, &c. The charities are exceed-



regal lodge, the post and telegraph offices, &c. There are also botanical gardens, several public parks, &c. The climate is tropical, the annual rainfall about 55 inches. The town is the terminus of the western and southern railway system, and the port is the principal one in the colony. Pop. 1891, 48,738.

**Bris'bane**, GENERAL SIR THOMAS MACDOUGALL, a Scotch soldier and astronomer, born in 1773. After serving in Flanders and the West Indies he commanded a brigade under the Duke of Wellington during the Peninsular war, and took part in the battles of Vittoria, Orthes, and Toulouse. In 1821 he was appointed governor of New South Wales, where his administration tended greatly to promote the prosperity of the colony. At the same time he devoted himself to astronomy, and from his obser-

ingly numerous, the most important being Ashley Down orphanage, for the orphans of Protestant parents, founded and still managed by the Rev. George Müller, which may almost be described as a village of orphans. Bristol has a number of endowed schools, the principal of which are the grammar-school, Queen Elizabeth's hospital, the Red Maids' school (which educates and provides for 80 girls, and gives them marriage portions), Colston's hospital, the trade school, and the cathedral school. Amongst the educational institutions are the University College, the Theological Colleges of the Baptists and Independents, Clifton College, and the Philosophical Institute. There is a school of art, and also a public library. Bristol has glass-works, potteries, soap-works, tanneries, sugar-refineries, and chemical works, ship-building and machinery yards. Coal is worked extensively within the limits of the borough. The export and import trade is large and varied. There is a harbour in the city itself, and the construction of new docks at Avonmouth and Portishead has given a fresh impetus to the port. Bristol is one of the healthiest of the large towns of the kingdom. It has an excellent water supply chiefly obtained from the Mendip Hills.—In old Celtic chronicles we find the name *Caer Oder*, or 'the City of the Chasm,' given to a place in this neighbourhood, a name peculiarly appropriate to the situation of Bristol, or rather of its suburb Clifton. The Saxons called it *Bricgstow*, 'bridge-place.' In 1373 it was constituted a county of itself by Edward III. It was made the seat of a bishopric by Henry VIII. in 1542 (now united with Gloucester). In 1831 the Reform agitation gave origin to riots that lasted for several days. The rioters destroyed a number of public and private buildings, and had to be dispersed by the military. Sebastian Cabot, Chatterton, and Southey were natives of Bristol. Since 1885 it returns four members to parliament. Pop 1891, 221,655.

**Bristol**, a seaport in Rhode Island, United States. It has a pleasant situation, is a favourite place of summer resort, and has a considerable trade. Pop. 5478.

**Bristol**, Bucks county, Pa. Pop. 6553.

**Bristol**, Hartford county, Conn., a prosperous manufacturing town. Pop. 7382.

**Bristol Channel**, an arm of the Atlantic, extending between the southern shores of Wales and the south-western peninsula of England, and forming the continuation of

the estuary of the Severn. It is remarkable for its high tides.

**Bristol-stone**, rock-crystal, or Bristol-diamond, small, round crystals of quartz, found in the Clifton limestone, near the city of Bristol in England.

**Britain**, or GREAT BRITAIN, the island consisting of the three countries, England, Scotland, and Wales, the name being also used as equivalent to the British Islands collectively, or to the British Empire. Great Britain and Ireland, with their connected islands, form the United Kingdom of Great Britain and Ireland.

The British Islands form a kind of archipelago in the north-west of Europe. The principal islands are Great Britain and Ireland, separated from each other by the Irish Sea, which, near the centre, attains its greatest width of about 130 miles; but between Holyhead in Wales and Howth Head in Ireland is not wider than 60 miles; while the distance between the Mull of Cantyre in Scotland and Fair Head in Ireland is only about 12 miles. Great Britain is the largest island in Europe, and the seventh largest in the world. Its nearest approach to the continent of Europe is at its s.e. extremity, where the Strait of Dover, separating it from France, is only 21 miles broad. Its length, measured on a line bearing n. by w. from Rye to Dunnet Head, is 608 miles. The breadth varies exceedingly; between St. David's Head, in Pembrokeshire, and the Naze, in Essex, it is 280 miles; between the Clyde at Dumbar-ton and the Forth at Alloa it is only 32 miles. The shape of Ireland is more regular than that of Great Britain, and bears a considerable resemblance to a rhomboid. Its greatest length going straight north and south is 230 miles, and its greatest breadth from west to east is 180 miles. The British Isles rise from a submarine plateau connecting them geologically with the rest of Europe, of which at a remote period they must have actually formed a part. This is evidenced too by the similarity of the British fauna and flora to the continental.

*Area of the British Isles.*

	Sq. Miles.	Acres.
England.....	50,823	32,527,070
Wales.....	7,363	4,712,282
Isle of Man.....	227	145,325
Channel Islands.....	75	48,322
Scotland.....	29,820	19,084,659
Ireland.....	32,531	20,819,928
Total.....	120,839	77,337,586

*Surface.*—The N. part of Britain is, for the most part, rugged, mountainous, and barren, this being the character of much of Scotland. To the N. of a line drawn from the Firth of Clyde on the W. to Stonehaven on the E. coast is the region generally known as the Highlands, divided into a northern and a southern portion by the great hollow of Glenmore through which runs the Caledonian Canal. The chief feature of the southern portion is the mountain mass of the Grampians, the culminating points of which, Bennevis and Benmacdhui, are the highest British summits, being respectively 4406 and 4296 feet. South of the Highlands lies the plain of the Forth and Clyde, a region of coal and iron, in which the chief manufacturing industries of Scotland are carried on. South of this again is the elevated region of the Southern Highlands or Southern Uplands, less rugged and more pastoral than the Highlands proper. Towards the S.E. are the Cheviot Hills, on the borders of England and Scotland. Here commences the long Pennine chain running south into England, branching off into the mountains of Cumberland and the Lake district (Cumbrian Mountains), and terminating beyond the Peak of Derby, in the heart of England. The highest summit of the English mountains is in the north-west (Lake district), namely, Scawfell, 3210 ft. Further south and west is the Cambrian range, spread over the greater part of Wales, and containing, among others, the highest mountain of S. Britain—Snowdon, 3571 feet. Over great parts of England the elevations are mostly insignificant, and the general character of the country is that of undulating plains. In Ireland the most marked feature is the dreary expanse of bogs which stretches over its interior. This flatness of the interior is caused by the fact that most of the mountain masses attain their greatest elevation near the coast, and rapidly decline as they recede from it. Carn Tual, in the south-west, the culminating point of the island, is 3404 feet high.

*Rivers and Lakes.*—The mountains which constitute the principal watersheds of Great Britain being generally at no great distance from the W. coast, the rivers which descend from them in that direction have generally a short course, and are comparatively unimportant. The two great exceptions to this rule are the Clyde and the Severn, which owe both their volume and the length of their course to a series of longitudinal val-

leys, which, instead of opening directly to the coast, take a somewhat parallel direction. The chief rivers entering the sea on the E. coast, proceeding from N. to S., are the Spey, Don, Dee, Tay, Forth, Tweed, Tyne, Ouse, Trent, and Thames, the last named in navigable importance the greatest river of the world. No river of importance empties itself either on the N. or S. coast. Owing to the great central flat of Ireland its rivers usually flow on in a gently winding course in different directions to the sea. Those of importance are not very numerous; but one of them, the Shannon, is the longest river of the British Isles, its length being about 225 miles; while the Thames is 215. The Tay (length 130 miles) is said to have the largest volume of water. The lakes of the British Isles are distinguished for beauty rather than size; the largest, but among the least interesting, is Lough Neagh, in the north of Ireland. While both Great Britain and Ireland are provided with numerous streams, which are either themselves navigable or act as the feeders of canals, the coasts supply a number of excellent harbours invaluable to the commerce of the country.

*Climate.*—Their maritime situation has a favourable effect on the climate of the British Isles, making it milder and more equable than that of continental countries in the same latitude. The temperature of the Atlantic, raised by the influx of the gulf-stream, is communicated to the winds and vapours which are wafted along its surface, and the prevailing winds in Britain being from the south-west, the country is kept constantly at a relatively high temperature. The south-west winds, too, are charged with vapour, and often bring rain, thus supplying the country with abundant moisture. Ireland, from its more westerly position, has these characteristics in the most marked degree, the warmth and moisture of the west winds making it markedly a 'green isle.' For the same reason the western shores of the islands have a milder and more equable temperature than the eastern shores, the former being on an average one or two degrees cooler in summer and several degrees warmer in winter. The range of temperature between the coldest and the warmest months is at London 26°, in England generally 24½°, while at Paris it is 30°. The range at Edinburgh is 25°, while at St. Petersburg it is 55°. The mean winter temperature at Dublin is

## BRITAIN.

39°, or 3 degrees higher than that of Milan, Pavia, Padua, or the whole of Lombardy.

*Agriculture.*—In almost every district in Great Britain where the plough can move, farming of a superior description may be seen, and, according to Professor Thorold Rogers, 'it may be confidently averred that owing to improvement in stock and seeds, agriculture in the United Kingdom is at a higher level than in any other country.' Thorough and systematic draining, the extensive use of artificial manure, and the employment of the newest implements are among the chief features of modern British agriculture. The ensilage method of preserving green fodder has recently been introduced, and promises to produce important results. A peculiar feature of English as distinguished from Scotch husbandry is the large amount of arable land forming permanent hay-fields. These are kept fertile by heavy doses of farmyard manure, and yield grass of admirable feeding qualities. Much of the land thus employed is naturally of poor quality, but by the careful management of perhaps a century has become covered with a close sward of the richest green, and of admirable feeding qualities. The great extent of the permanent pasture is also a feature of Irish agriculture. In the rearing and fattening of stock there is no country in the world that can be compared to several districts of Great Britain. It is sufficient to mention, among horses, the race-horse, the finest type, and the parent of the best existing breeds of that animal; among cattle, the shorthorns of Durham; and among sheep, the celebrated South Downs and Leicesters. The principal cereal crops grown in England are wheat, barley, and oats, wheat covering the largest area; the principal green crops are turnips, potatoes, mangolds, vetches, &c. In Ireland and Scotland oats are by far the principal grain crop; by far the chief green crop being in Ireland potatoes, in Scotland turnips. Hops are grown to a large extent in Kent, and less extensively in some other parts of southern England. The most marked feature in the agriculture of Great Britain during recent years is the gradual increase in the proportion which the amount of land in grass bears to that under corn and green crops; an increase without doubt attributable to the increased facility with which cereals can be obtained from foreign countries, making it more profitable for British farmers to devote themselves to the rearing of livestock.

Of the whole area of Great Britain less than 60 per cent is under the plough or in pasture; but in England the proportion is about 75 per cent, and in Wales above 60 per cent, while in Scotland it is under 25 per cent (so much of Scotland being barren). In Ireland the proportion is about 75 per cent. The agriculture of Ireland, though the soil itself offers every advantage to the farmer, is in a very different condition from that of Great Britain, being in a very backward state on the whole, mainly owing to the subdivision of holdings and to over cropping, combined with the ignorance and unskilfulness of the people.

The following table gives a general idea of the distribution of crops in the United Kingdom in 1891:—

	Great Britain.	Ireland.	United Kingdom.
	Acres.	Acres	Acres.
Under corn } crops.....	7,924,823	1,492,329	9,417,152
Under green } crops.....	3,297,569	1,190,943	4,488,512
Grasses under rotation, clover, &c .....	4,716,582	} 12,348,921	} 33,499,353
Permanent pasture.....	16,433,850		
Fallow land..	429,040	21,786	450,826

The total in crops, bare fallow, or grass thus amounted altogether to 47,855,843 acres. The total number of agricultural holdings in Great Britain is 555,855, in Ireland it is 564,803.

The following table shows the number of horses used in or connected with agriculture, and of cattle, sheep, and pigs in the United Kingdom in 1891:—

	Great Britain	Ireland.	United Kingdom
Horses.....	1,488,403	528,576	2,026,170
Cattle.....	6,852,821	4,448,477	11,343,986
Sheep.....	28,732,558	4,722,391	33,533,988
Pigs.....	2,888,773	1,367,776	4,272,764

*Minerals.*—Such is the mineral wealth of the British Isles that there is scarcely a metal or mineral product of economical value which is not worked, to a greater or less extent, beneath their surface. Among these the first place is due to *coal*, which, in regard both to the quantity raised annually and its aggregate value, surpasses any other mineral product. The coal-fields are not confined to one particular district, but extend as a series of basins in an irregular curve from central Scotland through northern and middle England to the Bristol



**Channel.** On the east side of Scotland there are coal-fields both north and south of the Forth; farther west lie the coal-basins of Lanark, Renfrew, and Ayrshire; the first famous throughout the world for the immense manufacturing establishments which it mainly has called into existence and made prosperous. In the north of England is the great coal-field centring near Newcastle, which gives it its name. The proximity of this field to the sea, and the excellence of the coal, unrivalled for domestic use, early made it a great theatre of mining operations. The next coal-field to the s. includes a large central space comprising parts of Yorkshire, Derbyshire, Nottinghamshire, and Lancashire, and divided by a separating belt of the lower strata of the carboniferous system into a kind of twin fields, the one of which extends from Leeds to Nottingham, while the other has its greatest length from s.w. to n.e., and borders, at its e. and w. extremities respectively, on Manchester and Liverpool. The only other coal-field of a magnitude similar to those already mentioned is that of South Wales. There are several minor fields, as the North Staffordshire, the Shropshire, the Warwickshire, and the South Staffordshire. No coal to speak of is got in Ireland. The output of coal in Great Britain in the year 1890 aggregated 181,614,288 tons. Of this about one-seventh is exported yearly. The estimated value of the total output is £74,953,997. The *iron* ores smelted in Great Britain are principally carbonates. The most important iron-stone districts are those of Yorkshire, especially the rich Cleveland district in the North Riding, Lancashire, Cumberland, Staffordshire, Lincolnshire, Northamptonshire, and the coal-measures of Scotland. Blast furnaces are most numerous in Yorkshire, Staffordshire, Cumberland, Durham, Lancashire, S. Wales, and Lanarkshire. The quantity of pig-iron produced, 1891, was 7,406,000 tons; steel (Bessemer and open-hearth) 3,579,000 tons. Tin, lead, and zinc are the metals next in importance to iron. The value of the lead produced in 1891 was £400,687; of tin £881,139; of zinc, £212,495. Another important article is salt, chiefly from rock-salt and brine pits, the quantity produced in 1891 being valued at £976,824. Granite, free-stone, and roofing-slate quarries are numerous, except in the south-eastern part of England. The total estimated value of the minerals raised in 1890 was over

£92,794,400, of which Ireland's contribution was £380,000.

*Fisheries.*—The principal British fisheries are those of salmon, herring, haddock, ling and cod, turbot, soles, and other flat fish. The first is carried on chiefly in the rivers and estuaries of Scotland and Ireland; the second chiefly on the coasts and islands of Scotland, large quantities of herrings being cured and exported. Cod, haddocks, &c., are caught in great multitudes in the North Sea, particularly on the Dogger Bank. Among minor fisheries may be mentioned those of mackerel, pilchards, oysters, and lobsters. The facilities for conveyance now offered by railways has given a great impulse to the trade in fresh fish, and the London market alone draws to itself a large share of the fishing results all round the coasts. The total value of the fish caught in 1890 was £6,743,922.

*Manufactures.*—Taking these in the order of their importance, we begin with *cotton*. In this branch of industry Great Britain still remains a long way ahead of other countries. The Liverpool and Manchester district and S. Lancashire as a whole are the chief seats of the manufacture. The total value of the cotton goods (including yarn) exported in 1890 was £74,430,749; in 1891, £72,439,704. The peculiar excellence of the wool furnished by the English flocks made *woollens* the most ancient and for centuries the staple manufacture of England. Now this manufacture is next in importance to that of cotton, and draws largely for its supplies on other countries, particularly on the Australian colonies. The chief seats of the woollen manufacture are in England—the West Riding of Yorkshire, Lancashire, Gloucestershire, and Wiltshire being the most distinguished for broad-cloths; Norfolk for worsted stuffs, Leicestershire and Nottinghamshire for woollen hosiery. Blankets and flannels have numerous localities, but for the finer qualities the West of England and several of the Welsh counties are most conspicuous. Carpets of every quality and pattern are extensively made at Kidderminster, Halifax, Leeds, &c. The woollen manufacture of Ireland is on a very limited scale, being confined to a few broad-cloth factories, and a few blankets and flannels. Scotland has made much more progress, but still bears no proportion to England. The chief seats of the Scotch woollens are Kilmarnock for carpets, bonnets, and shawls; Stirling and its neighbour-

## BRITAIN.

hood for carpets and tartans; Ayrshire for blankets, &c.; Galashiels, Selkirk, and other places in the basin of the Tweed for the cloth known as 'tweeds,' the manufacture of which originated here, though it has since extended to several parts of England. The value of the woollen and worsted manufactures (including yarn) exported from Great Britain in 1891 was £22,362,219. The quantity of wool imported (a good deal being re-exported) was 656,000,000 lbs. The *linen* manufacture is also important. In England the chief seat of the manufacture is Leeds and its vicinity, and other parts of the West Riding; also parts of Lancashire and Durham. Linen is the only staple of Ireland, where it is carried on chiefly in the province of Ulster, Belfast being the great centre of the industry. In Scotland the manufacture is important. Besides plain linen, it includes osnaburgs, sheetings, sail-cloth, sacking, &c. — chief seat, Dundee (with other Forfarshire towns); and diaper and damask — chief seat, Dunfermline. The staples of both towns are by far the most important of their kind in the kingdom. Large quantities of jute are also used in this manufacture, especially at Dundee. The value of the linen and jute manufactures (including yarn) exported in 1891 was £8,824,123. The *silk* manufacture is the only great textile industry in regard to which, at least in finer fabrics, Britain must yield the palm of superiority to other countries. The chief seats of the trade in England are the district of Spitalfields in London, Manchester, and Coventry. Besides the manufactures already mentioned, there are a great number which, though separately of less importance, absorb immense sums of capital, exhibit many of the most wonderful specimens of human ingenuity, and give subsistence to millions of the population. Amongst the most important of these are the several branches of the hardware industry, the manufacture of steam-engines and all kinds of machinery, of arms and ammunition, of plate, jewelry, and watches, of chemicals, dyes, manures, &c., of furniture, of glass, earthenware and porcelain, &c. Of vast extent also is the paper manufacture, in connection with which are various industries, of which it may be considered as, directly or indirectly, the parent—type-founding, printing, books, engraving, &c. Another very important industry is that of ship-building, which has its chief seats in the Clyde and Tyne.

*Commerce.*—Of the extent of the commerce carried on by railway, river, canal, and highway there are little or no means of forming an estimate; but the foreign trade of the country can be stated with some approach to exactness. In 1890 the total value of merchandise imported into Great Britain was £420,885,695; exported £327,891,591. In 1891 there was an increase in imports, but a decrease in exports—imports, £435,691,279; exports, £309,068,866. Amongst the items which make up these sums were, on the side of imports, in 1891: grain and flour, £61,571,504; raw cotton, £46,080,719; wool, £27,856,556; sugar, raw and refined, £19,855,750; timber, £14,829,571; metals, £20,458,143; dead meat, £20,148,874; animals, £9,246,398; butter and margarine, £15,149,384; tea, £10,775,345; silk manufactures, £11,017,157; flax, hemp, and jute, £10,116,591; woollen manufactures, £9,275,179. Chief exports: cotton, woollen, and linen manufactures (as above), £103,626,046; iron and steel, wrought and unwrought, £26,874,784; machinery, £15,820,316; apparel and haberdashery, £5,150,212. Britain carries on commerce with almost all countries. The trade with her own colonies and dependencies is very large, but not more than one-third as much as with foreign countries. The foreign as well as the inland trade is greatly promoted by the highly developed system of communication which now exists. Thus January 1, 1891, there were 20,073 miles of railway open in the United Kingdom, of which about 14,119 miles belonged to England and Wales. For proportion of railways to area England taken by itself stands before any other country, having 1 mile of railway to  $4\frac{3}{4}$  miles of surface. In year 1891 1705½ million letters were delivered in the United Kingdom, giving an average of 45 per head of population. The total length of telegraph wires was 194,312 miles, the system as a whole belonging to the state. The number of messages sent year ending Mar. 31, 1891, 55,658,088. The total number of vessels registered as belonging to the kingdom in 1890 was 21,591, of 7,978,538 tons, of which 5,042,517 tons belonged to steam vessels. The total shipping entered was 84,574,324 tons, cleared 79,766,033. The development of British shipping, when compared with that of other nations, is even more remarkable than that of its foreign commerce. Not only is the great bulk of the trade between Britain and other foreign countries carried

## BRITAIN.

on in British ships, but so also is a large part of the trade between one foreign country and another. Hence we find, that the magnitude of the mercantile marine of the United Kingdom is far greater than that of any other country, its sea-going tonnage being double that of the United States, and more than seven times that of France.

*Religion.*—Every form of religion enjoys the most complete toleration, but there are two churches, one in England having an Episcopal form of government, and one in Scotland with a Presbyterian organization, established by law and partly supported by state endowments. Both of these are Protestant, and both in England and Scotland the great majority of those who do not belong to the established church are also Protestants. In England, however, these all belong to churches having a different organization from that of the Anglican Church, while in Scotland most of them belong to churches virtually identical with the established church both in creed and in organization. In Ireland there has been no state church since 1871, when a branch of the Anglican Church there established was disestablished. The great majority of the people are Roman Catholics.

*Education.*—All education in England was long entirely voluntary. The first comprehensive measure for the promotion of elementary education by the state was passed in 1870. Its chief provisions were for the election of school-boards in districts in which there was a deficiency of school accommodation, with power to build and maintain schools out of rates levied for the purpose, and for the giving of aid by parliamentary grant to these board-schools as well as to previously existing schools. Discretionary power was originally given to the school-boards to enforce the attendance of children in their districts, but by subsequent enactments compulsory attendance of children at school from 5 to 14 years of age has been made the law for the whole of England and Wales, a school-attendance committee being established to look after this matter wherever there is no school-board. The schools directly under school-boards still form but a small minority, being only, in 1890, 4714, out of a total of 19,419, all examined by government inspectors. But the population under school-boards is considerably greater than that under school-attendance committees. The most numerous schools are those connected with the National Society or the Church of

England. The average attendance in 1890 was 3,717,917. The Scotch Education Act, passed in 1872, was from the first more comprehensive than the English one, requiring the election of school-boards in every burgh and parish, and making school-attendance compulsory throughout the country. The school age is from 5 to 13. The elementary schools in 1890 numbered 3117, the average attendance was 519,738. Ireland is still far behind in the matter of education. Elementary education there is under the superintendence of the commissioners of national education, a body incorporated in 1845, with power, among other things, to erect and maintain schools wherever they think proper. The average attendance in these national schools was 489,144 in 1890. There is no compulsory school-attendance in any part of Ireland. Free education—the entire abolition of fees—throughout the United Kingdom is advocated by some. Secondary education in Britain is left almost entirely to private enterprise, though some measures in furtherance of it have recently been taken by government. In England there are a number of endowed grammar-schools, and also the great public schools of Eton, Harrow, Winchester, Rugby, Charterhouse, Westminster, &c. In Scotland and Ireland also there are a number of secondary schools; but they form no part of an organized system. Valuable results have been accomplished by the Department of Science and Art; and technical education is beginning to receive attention.

For the higher education there are in England the universities of Oxford, Cambridge, London, Durham, and the Victoria University, Manchester; and in addition to these, colleges, some of them called 'University colleges,' at Leeds, Newcastle, Nottingham, Bristol, Birmingham, and other places, besides other institutions giving a university education in one or more departments; the training institutions for teachers; and the colleges belonging to the different dissenting bodies. London University is properly only an examining board, but in connection with it there are in London, University College and King's College. In Scotland there are the four universities of Edinburgh, Glasgow, Aberdeen, and St. Andrews, a university college at Dundee, and the normal or training schools of the different religious bodies. Ireland has the University of Dublin, the Queen's Colleges of Belfast, Cork, and Galway, in connec-

## BRITAIN.

tion with the Royal University of Ireland, which is merely an examining and degree-conferring body; the Roman Catholic university, and Maynooth and other R. Catholic colleges. As was to be expected, the expenditure in connection with popular education has greatly increased since the passing of the education acts. The annual parliamentary grants, which in 1840 amounted to £30,000, had risen in 1870 to £914,721, and in 1891 to £5,881,986.

*People.*—The earliest inhabitants of the United Kingdom known to history were Celts, who inhabited both Great Britain and Ireland at the time of the Roman occupation. In the 5th and 6th centuries, however, the Celts were displaced through the greater part of South Britain and in the eastern lowlands of North Britain by the Anglo-Saxons, a Teutonic race from which the modern English and Lowland Scotch are mainly descended. The Celts as a distinct people were gradually confined to the mountainous districts of Wales and Cornwall and the Highlands of Scotland, and only in Wales and Scotland has the Celtic language survived in Great Britain, being still also spoken by many in the west of Ireland. There is a considerable Celtic element, however, among the population everywhere. The English language is the direct descendant of that spoken by the Anglo Saxons, but contains a strong infusion of French elements introduced by the Normans in the 11th and following centuries, as well as other elements, chiefly of Latin and Greek origin, introduced in later times.

The population of the United Kingdom is very unequally distributed in the three countries of which the kingdom is composed. England and Wales had, in 1891, a population equal to 498 to the square mile, which is a denser population than any country in Europe except Belgium and Saxony; that of Ireland at the same date was 144 to the square mile, and that of Scotland only 132. Except Middlesex, which is largely occupied by the metropolis, the most densely populated country in England is Lancashire, which has a population of above 2070 to the square mile, and the population of the two counties of Lanark and Renfrew in Scotland shows a ratio of above 1150 to the square mile; while East and West Flanders in Belgium, the most densely populated district on the continent of Europe, have a population of only about 700 to the square mile. The increase that has taken place in the population of Great Britain during the present century is very remarkable. At the first census, which took place in 1801 (and which did not include Ireland), the whole population of Great Britain was found to be a little under eleven millions; at the census of 1891 it was 33,034,121. The growth in the population of the whole kingdom between 1831, the date of the first reliable Irish census, and 1891 was from 24,400,000 to 37,888,000. This growth, however, was confined to Great Britain, for in Ireland the population has greatly declined (in 1841 it was fully 8,000,000). The population of the British islands was as follows in 1881 and 1891:—

Divisions.	Males.	Females.	Total, 1891.	Total, 1881.
England } .....	14,050,620	14,950,398	{ 27,482,104	24,613,926
Wales } .....				1,360,513
Scotland .....	1,951,461	2,081,642	4,033,103	3,735,573
Ireland .....	2,317,076	2,389,086	4,706,162	5,174,836
Isle of Man.....	—	—	55,598	53,558
Channel Islands....	—	—	92,272	87,702
Soldiers and } sailors abroad } .....	—	—	—	215,374
Total.....	—	—	37,888,153	35,241,482

The population in 1891 was 37,888,153, namely, England and Wales 29,001,018, Scotland 4,033,103, Ireland 4,706,162, Isle of Man 55,598, Channel Islands 92,272.

*Extent of Empire.*—The area of the British empire, including recent acquisitions in Africa, is 12,208,506 square miles, with a population of about 378,946,973, distributed as follows:—British Isles and posses-

sions in Europe (Gibraltar, Malta and Gozo); area, 121,000 square miles; population, 1891, 38,300,860; British India and feudatory states, Ceylon, Straits Settlements, Hong Kong, &c., in Asia; area, 1,827,234; population 291,014,006; Cape Colony, Natal, Sierra Leone, Mauritius, St. Helena, and other possessions in Africa, or islands adjacent, 359,073 square miles; pop. about

## BRITAIN.

4,961,500; Canada, Newfoundland, Jamaica, Trinidad, and other West India islands; Honduras, Guyana, and all possessions in America, north or south, 3,614,224 square miles; pop. 6,721,251; Australia, Tasmania, New Zealand, Fiji, New Guinea, &c.; area, 3,259,199 sq. miles; pop. 4,285,297. The increase of British colonies, especially of Canada and Australia, in population, wealth, and trade, has been something prodigious within the last few years. Self-government has been conceded to the larger colonies.

*Constitution.*—Under the name of a constitutional and hereditary monarchy the government of Britain is vested in a sovereign and the two houses of parliament—the House of Lords and the House of Commons. Laws passed by these houses, and assented to by the sovereign, become the laws of the land. But under this general fixity of form the centre of real power may change greatly, as it has in Great Britain within the last two centuries. The sovereign's right of veto on acts of parliament has practically passed into desuetude, while of the two legislative houses the House of Commons, from its being the expression of the national will as a whole, has become the real centre of power and influence. Popular rights and liberties are thus secured by the fact that the most influential part of the legislature is composed of members dependent on the confidence and trust of popular constituencies. Thus though the powers of the parliament may be regarded as unlimited, yet it must always in the end give way before a decided and clear expression of public opinion. It is often said, therefore, that the constitution of Great Britain is in great part an unwritten law, and this unwritten law is continually receiving additions and adapting itself to the new forces and needs of the time. This natural flexibility of the British constitution is one of its greatest merits, and what most distinguishes it from the more rigid systems of other countries. One of the best examples of this quiet growth of unwritten law is the position occupied by such a body as the cabinet, a body never officially recognized by any act of parliament, and wholly unknown to the written law, yet practically the highest executive body in the kingdom, though nominally the executive government is vested in the sovereign. On this subject the late Mr. Bagehot remarks: 'The efficient secret of the English constitution may be described as the

close union, the nearly complete fusion, of the executive and legislative powers. According to the traditional theory as it exists in all the books, the goodness of our constitution consists in the entire separation of the legislative and executive authorities, but in truth its merit consists in their singular approximation. The connecting link is the cabinet. By that new word we mean a committee of the legislative body selected to be the executive body.'

*The Sovereign.*—The fundamental maxim upon which the right of succession to the throne depends is, that the crown is, by common law and constitutional custom, hereditary, and that the right of inheritance may from time to time be changed or limited by parliament; under which limitations the crown still continues hereditary. It descends to the males in preference to the females, strictly adhering to the rule of primogeniture. The sovereign is of age at eighteen years. The heir to the crown has, since the time of Edward III., inherited the title of Duke of Cornwall, and receives that of Prince of Wales by letters patent. The power of the sovereign is limited by the laws. The divine right, so obstinately maintained by the Stuarts, was never recognized by the nation, and William III., Mary, and Anne ascended the throne, according to express declarations, only by virtue of a transmission of the crown to them by the nation. But the maxim has been acknowledged, particularly since the Restoration, that there is no power in the state superior to the royal prerogatives: the acts of the king are therefore subject to no examination, and the king is not personally responsible to any tribunal: hence the maxim, The king can do no wrong. Yet there is sufficient provision for confining the exercise of the royal power within the legal limits. 1. All royal acts are construed in accordance with the laws, and it is taken for granted that the king can never intend anything contrary to law. 2. The counselors of the king are responsible for the royal acts, and, as well as all those who are concerned in the execution of them, are liable to impeachment and examination, without the right of defending themselves by pleading the royal commands. 3. The parliament and the judicial tribunals have also the right to discuss freely such royal acts, and, in particular, parliament and each individual member of the upper house, has the right to make remonstrances to the

crown. 4. Individuals are protected from any abuses of the royal power by the Habeas Corpus Act, the liability of the agents to prosecution, the right of complaining to parliament, and the liberty of the press.

The king is the supreme head of the state in peace and war, the lord paramount of the soil, the fountain of justice and honour, and the supreme head of the church. He has the prerogative of rejecting bills in parliament, which, however, has not been exercised since the year 1692. As the generalissimo, or the first in military command within the kingdom, he has the sole power of raising and regulating fleets and armies, which, however, is virtually controlled by the necessity he is under of obtaining supplies from parliament. As the fountain of justice, and general conservator of the peace of the kingdom, he alone has the right of erecting courts of judicature, and all jurisdictions of courts are derived from the crown. As the fountain of honour, of office, and of privilege, he has the power of conferring dignities, privileges, offices, &c. In the foreign relations of the nation he is considered the nation's representative, and makes treaties, declares war, &c. As advisers he has the privy-council and the cabinet (which see).

*The Parliament.* — The origin of the British Parliament has been sought rightly enough in the *witenagemôts* or national assemblies of the Anglo-Saxons. In a somewhat different form these were continued in the Norman times, and as early at least as the reign of Henry III. we find not only the barons and the high ecclesiastics, but also the knights of the shire with the burgesses summoned to attend. These formed the *three estates*, now known as the lords spiritual, the lords temporal, and the commons. In the reign of Edward III. (1327–77) the separation of the estates into two houses — the House of Lords, consisting of the lords spiritual and the lords temporal, and the House of Commons, consisting of the knights, citizens, and burgesses — became settled. All the peers were not originally entitled to a seat as a matter of right, but only those who were expressly summoned by the king. Every hereditary peerage now, however, confers the right of a seat in the House of Lords or Upper House. The number is indefinite, and may be increased at the pleasure of the crown, which, however, cannot deprive a peer of the dignity once bestowed.

The upper house at present comprises about 560 members. By the act of union with Scotland, 16 representatives of the Scottish peerage are elected by the Scottish nobility for each parliament's duration (seven years), and 28 are elected for life by the peers of Ireland.

The parliament is not permanent, and it is the royal prerogative to summon and dissolve it. The first business of the Commons is to elect a speaker. The members then take the oath of allegiance, and when this is done the queen's speech is read, being answered by an address from each house. In the upper house the lord-chancellor presides, holding the position of the speaker in the Commons. All grants of subsidies or parliamentary aids must originate with the House of Commons, and the Lords have not the right to amend, but only to accept or reject, a money bill. As the parliament is summoned, so it is prorogued by the royal authority. A dissolution of the parliament is effected either by the authority of the crown, or by length of time. The House of Commons being chosen but for seven years, at the expiration of that time parliament is dissolved *ipso facto*. The lower house of parliament has the direction of all financial concerns; and there is no subject which may not be brought before it by petition, complaint, or motion of a member. The upper house is the supreme court of judicature in the nation. In civil cases it (now represented by the Lords of Appeal in Ordinary) is the supreme court of appeal from the superior tribunals of the three kingdoms. In indictments for treason or felony, or misprision thereof, where the accused is a peer of the realm, the House of Lords are the judges of the law and the fact. In cases of impeachment by the House of Commons the House of Lords are also the judges. All the forms of a criminal trial are then observed, and the verdict must be by a majority of at least twelve votes.

The House of Commons previous to the Reform Bill of 1832 consisted of 658 members, of whom 513 were for England and Wales, 45 for Scotland, and 100 for Ireland. In this representation there were great injustices and anomalies. Many of the boroughs had quite fallen into decay, so that a place like the famous Old Sarum, which consisted only of the ruins of an old castle, sent two members to parliament, while great manufacturing towns like Manchester and

Birmingham were absolutely without representation. Not only the *rotten boroughs*, as these decayed constituencies were called, but also in many cases the towns, where the right of suffrage belonged to a small number of freeholders, were practically in the hands of a single family, and in this way a few great houses—Norfolk, Bedford, Devonshire, and the Pelhams, &c.—commanded more than 100 seats in parliament. For the few places that were in the hands of independent voters a shameless system of bribery existed, in spite of the prohibitory laws, and the prices of votes were generally well known: a seat for a small place cost about £5000. The Reform Bill of 1832 brought great changes. Occupiers of lands or tenements in counties at a yearly rent of not less than £50, and occupiers as owner or tenant of a house or shop in a borough of a yearly value of £10, now received the franchise. Fifty-six rotten boroughs were wholly disfranchised; thirty boroughs were deprived of one member; and one borough (Melcombe-Regis cum Weymouth, which had four) of two members; twenty-two boroughs were created in England, to return two members each, and nineteen boroughs to return one member each. Besides taking away the right of election from many insignificant places, and vesting it in large, or at least in tolerably numerous, constituencies in new boroughs, the act introduced something like uniformity in the qualifications of the voters of the old boroughs and cities, and extended the elective franchise from close corporations, or privileged bodies, to the citizens at large.

After several unsuccessful attempts by Lord John Russell, Lord Palmerston, and Mr. Gladstone to pass bills for further reform, in 1867 Mr. Disraeli, then chancellor of the exchequer, succeeded in carrying through a bill which conferred the borough franchise on all householders who had resided in the borough for twelve months previous to the last day of July in any year, and had been assessed for and paid poor-rates, and on all lodgers who had occupied for a like period lodgings of the yearly value of £10 unfurnished. In counties the franchise was bestowed on occupiers as owners or tenants of subjects of £12 ratable value, and the copyhold and leasehold franchise was reduced from £10 to £5. This bill related only to England and Wales, but bills of a similar character were passed for Scotland and Ireland in the following year. In this

way the electorate, which was 1,352,970 in 1867, rose to 2,243,259 in 1870. The total number of members still remained at 658. To Manchester, Liverpool, Birmingham, and Leeds were assigned three members each, and to London University one. Populous counties were further divided, and to many of the divisions two members each were given.

From the union of Scotland with England in 1707 till 1832 the former returned forty-five members to the House of Commons, thirty for the thirty-three counties, and fifteen for fifteen districts of burghs. Superiors, or persons holding directly from the crown, alone voted in the counties. In two counties there were only three real voters in each. The number of persons who actually voted at the elections of the burghs was very inconsiderable, consisting, in general, of the magistrates and town council, amounting only to twenty in each burgh, or in all the sixty-six burghs to 1320. By the Scotch Reform Act of 1832 eight members were added to the representation; Edinburgh and Glasgow receiving two each, and Aberdeen, Dundee, Greenock, Perth, and Paisley one each. The right of voting was also placed as near as possible on the same footing as in England; but the number of members, though increased, was not in proportion with the constituency of England or even Ireland. By the Scotch Reform Act of 1868 the burgh franchise was assimilated to that of England, being conferred on householders, but in counties the occupation tenure was £14 or upwards. Seven additional seats were given: one to the universities of Aberdeen and Glasgow, one to those of Edinburgh and St. Andrews, one to Glasgow city (which now had three), one to Dundee (which now had two), and one each to the counties of Lanark, Ayr, and Aberdeen, which were divided into two divisions, each returning a member.

Since the legislative union with Britain in 1801 Ireland had sent 100 members to the House of Commons. By the Reform Act of 1832 five members were added, and £10 copyholders, &c., admitted amongst the classes of county voters. In 1850 occupiers of land rated at £12 a year were admitted to vote. In the borough franchise the £10 qualification for owner or occupant was adopted in the reform of 1832, much the same as in England; and by the act of 1850 the franchise was further extended to £8

BRITAIN.

occupiers. By the reform bill of 1868 the occupation franchise in towns was reduced from £8 to £4, and for lodgers it was fixed at the same as in England and Scotland.

The Representation of the People Act of 6th Dec. 1884, established a uniform householder and a uniform lodger franchise throughout the kingdom. Equally important changes were effected by the Redistribution Act passed in June, 1885. By it 79 small boroughs in England and Wales (including four districts of boroughs in the latter) and 24 in Ireland ceased to return members separately, while in Scotland the Haddington and Wigton districts of burghs lost the burgh franchise. In England 36 small boroughs, and in Ireland 3, lost one member each. The members for Liverpool were increased to 9, for Birmingham, the Tower Hamlets, and Glasgow to 7 each, for Manchester to 6, for Leeds and Sheffield to 5 each, and other important centres in proportion. Thirty-three new boroughs, chiefly in the London Metropolitan district, were created. Many of the larger boroughs were divided and a member given to each division; large counties were dealt with in a similar way. The numerical strength of the house was also raised, the gross number of members being 670, of which England gets 465 (2 additional), Wales 30 (as before), Scotland 72 (12 additional), and Ireland 103 (2 less). The following is a summary of the distribution of members according to the act of 1885:—

England,	{	4 counties with 2 members each, 5 with 3 each, 9 with 4 each, 5 with 5 each, 4 with 6 each, 5 with 7 each, 5 with 8 each, Lancashire with 23, Yorkshire with 26, Rutland and Isle of Wight with 1 each, . . . . .	234	}	465
		8 cities and boroughs with 1 each, 28 with 2 each, 9 with 3 each, and 5 with 4 each, . . . . .	187		
		Leeds and Sheffield 5 each. Manchester 6, Birmingham and Tower Hamlets 7 each, and Liverpool 9, . . . . .	39		
		Universities, . . . . .	5		
Wales,	{	8 counties 1 each, 3 with 2 each, Glamorgan 5, . . . . .	19	}	30
		7 districts of boroughs 1 each, Swansea and Merthyr Tydvil 2 each, . . . . .	11		
Scotland,	{	23 counties with 1 each, 5 with 2 each, Lanarkshire 6, . . . . .	39	}	72
		16 burghs with 1 each, 2 with 2 each, Edinburgh 4, Glasgow 7, . . . . .	31		
		Universities, . . . . .	2		
Ireland,	{	21 counties with 2 each, 8 with 4, 1 with 7, 1 with 1, 1 with 3, . . . . .	85	}	103
		6 boroughs with 1 each, 2 with 4 each, 1 with 2, . . . . .	16		
		University, . . . . .	2		
Total, . . . . .				—	670

*Ranks and Titles.*—The laws acknowledge only two distinctions of rank or civil status, the nobility and the commonalty. The dis-

tinction is by no means like that between the patricians and plebeians in ancient Rome, nor that between the nobles and citizens of France in the last century, and the peculiar privileges of the nobility are few and insignificant. Intermarriages with commoners are usual, and the sons of peers mingle with commoners in the House of Commons, where wealth, talent, and industry are at least as well represented as birth. Moreover, the House of Lords is continually recruited from the House of Commons by the conferring of peerages on its more distinguished members. The peers are exempted from the performance of a few little public services, such as sitting on juries, &c. They have also a right to be tried by the House of Lords on indictments for treason, or felony, or misprision thereof; but the administration of justice before this tribunal is as strict as in the ordinary courts. Their persons cannot be arrested in civil cases. The titles borne by those who form the peerage are, in a descending scale, duke, marquis, earl, viscount, baron. Of these earl is the oldest, this title dating from the Anglo-Saxon period, when it was equivalent to that of *ealdorman* or governor of a shire. The other ranks at this early period were those of the *athelings*, or princes of royal blood; *thanes*, who were royal officers or considerable landowners; and the *ceorls*, or husbandmen, below whom were the serfs or slaves. After the Conquest the title of *baron* came into use. The *barons* formed an inferior class of nobles to the earls, though the term might also be used to include all the peers. The title of *duke* arose under Edward III., who created his eldest son Duke of Cornwall (1337). The title of marquis was introduced in the time of Richard II.; that of viscount during the reign of Henry VI. It is only the actual holders of these titles who are, strictly speaking, the nobility; their families are only noble by courtesy. The chief privilege that the titles confer is a seat in the House of Peers or—since the term *lord* is often used as equivalent to *peer*—the House of Lords. The Scottish and Irish peers sit in the house only by deputation; but many Scottish and Irish peers have also titles belonging to the peerage of Great Britain or the United Kingdom in virtue of which they sit; thus the Duke of Argyll sits as Baron Sundridge. The titles of nobility just mentioned are inherited by the eldest son, who, during the life of the father, bears by courtesy his next highest title if he is a



duke, marquis, or earl; if the father be a viscount or baron the son is only an 'honourable.' (See *Address, Forms of.*) Any of the sons of a duke or marquis is called *lord*, but only the eldest son of an earl is so called. Next below the rank of the nobility are the *baronets*. This dignity was created by James I. in 1611, and descends to the eldest son. There are no privileges annexed to the baronetcy, but the title is considered as an honour, and is often bestowed on men who have distinguished themselves in a civil or military capacity. Below the baronets are *knights* (who also have *Sir* before their names) and esquires, and all others that may be classed among the gentry. This last term is sufficiently vague, but may be said to include the richer landed proprietors, and all to whom wealth, office, or talents have secured a certain respect and standing in society. All these may be said to have a claim to be considered as of the rank of esquires, which, however, by law is somewhat restricted in its application.

*Army and Navy.*—The British army is raised on the authority of the sovereign, who is looked on as its head; but the number of troops and the cost of the different branches are regulated annually by a vote of the House of Commons. In 1891–92 the army comprised a total of 707,242 men, namely: regular forces at home and in the colonies, 143,849; army reserve, 72,710; militia, 141,488; yeomanry cavalry, 14,086; volunteers, 262,613; forces on Indian establishments, 72,496. The annual expenditure on the army has considerably increased in recent times, and at present is usually about £17,000,000 or £18,000,000. No British citizen is obliged to bear arms except for the defence of his country; but all able-bodied men, from eighteen to thirty-five, are liable to militia service, the militia being raised, when required, by ballot. Enlistment among the regulars is either for twelve years' army service (long service), or for seven years' army service and five years' reserve service (short service). The head of the military administration is the secretary of state for war. See *Army*.

The administration of the navy is carried on by the Board of Admiralty, consisting of six members, and having at its head the First Lord, who has supreme authority. The estimates for 1891–92 made provision for a total of 66,800 men and boys in the naval service, of whom 44,734 were officers and seamen, 13,879 marines, in addition to

4200 for the coastguard, making in all a force of 71,000 men and boys. The total estimated expenditure on the navy in 1891–92 was about £15,210,620. The most important and formidable portion of the navy is the armour-clad fleet, which consists of about seventy vessels, including those not yet completed. See *Iron-clad Vessels*.

*Finance, Revenue and Expenditure.*—The practice of borrowing money in order to defray a part of the war expenditure began in the reign of William III. At first it was customary to borrow upon the security of some tax, or portion of a tax, set apart as a fund for discharging the principal and the interest of the sum borrowed. This discharge was, however, very rarely effected, and at length the practice of borrowing for a fixed period was almost entirely abandoned, and most loans were made upon *in-terminable* annuities, or until such time as it might be convenient for government to pay off the principal. Originally the interest paid by the government on these loans was comparatively high and subject to considerable variation. But in the reign of George II. a different practice was adopted. Instead of varying the interest upon the loan, the rate of interest was generally fixed at three or three and a half per cent, the necessary variation being made in the principal funded. Thus, if government were anxious to borrow in a three-per-cent stock, and could not negotiate a loan for less than four and a half per cent, they effected their object by giving the lender, in return for every £100 advanced, £150 three-per-cent stock—that is, they bound the country to pay him or his assignees £4, 10s. a year in all time to come, or, otherwise, to extinguish the debt by a payment of £150. In consequence of this practice the principal of the debt now amounts to far more than the sum actually advanced by the lenders. At the death of William III. the public debt, partly by reason of the long wars, amounted to £16,394,702, the public income being £3,895,205. By far the greater part of the next reign also was a time of war, and on the death of Queen Anne the national debt amounted to £54,145,363. The reign of George I. was undisturbed by war, which enabled the government of the time to reduce the debt by £2,053,125, so that at the accession of George II. the whole amount of the debt was £52,092,238. At the conclusion of the Peace of Paris after the Seven

Years' War it was £138,865,430, and at the end of the American war, £239,350,148. During the French war £601,500,334 of new debt was contracted, and on the 1st of February, 1817, when the English and Irish exchequers were consolidated, the total debt was £840,850,491. Since then the debt has been greatly reduced, and at March 31st, 1891, the whole amount of it was £680,681,581. This includes both a funded and an unfunded debt. The latter species is that for which no formal provision has been made. The form in which it mostly exists is that of exchequer bills, which bear interest at a certain rate per cent per day, and pass from hand to hand like bank-notes. After a certain time they are received in payment of taxes or other moneys due to government; and the interest due on them at the time is allowed in the payment. In 1891 the total debt was divided as follows:—Funded, £579,472,082; terminable annuities, estimated capital value at 3 per cent., £68,458,798; unfunded, £36,140,079. The public revenue and expenditure have considerably increased in recent times, and in 1887–88 were respectively £89,802,254 and £87,423,645, in 1888–89 £86,827,000 and £86,614,944, while the estimated revenue for 1890–91 was £87,377,000, the expenditure £87,732,855. To the revenue of 1890–91 customs contributed £19,753,907; excise, £29,178,468; stamps, £15,827,498; property and income-tax, £13,143,932; post-office, £9,843,269. The chief items of expenditure were: national debt, £25,000,000; army, £17,560,023; navy, £14,125,358; civil services (including education, law and justice, &c.), £16,040,131; post-office, £5,682,562.

*History.*—The island in the remotest times bore the name of *Albion*. From a very early period it was visited by Phœnicians, Carthaginians, and Greeks, for the purpose of obtaining tin. Cæsar's two expeditions, 55 and 54 B.C., made it known to the Romans, by whom it was generally called *Britannia*; but it was not till the time of Claudius, nearly a hundred years after, that the Romans made a serious attempt to convert Britain into a Roman province. Some forty years later, under Agricola, the ablest of the Roman generals in Britain, they had extended the limits of the *Provincia Romana* as far as the line of the Forth and the Clyde. Here the Roman armies came into contact with the Caledonians of the interior, described by Tacitus as large-limbed, red-

haired men. After defeating the Caledonians under Galgacus at 'Mons Grampius' Agricola marched victoriously northwards as far as the Moray Firth, establishing stations and camps, remains of which are still to be seen. But the Romans were unable to retain their conquests in the northern part of the island, and were finally forced to abandon their northern wall and forts between the Clyde and the Forth and retire behind their second wall, built in 120 A.D. by Hadrian, between the Solway and the Tyne. Thus the southern part of the island alone remained Roman, and became specially known as *Britannia*, while the northern portion was distinctively called *Caledonia*. The capital of Roman Britain was York (*Eboracum*). Under the rule of the Romans many flourishing towns arose. Great roads were made, traversing the whole country and helping very much to develop its industries. Christianity was also introduced, and took the place of the Druidism of the native British. Under the tuition of the Romans the useful arts and even many of the refinements of life found their way into the southern part of the island.

Thus from the time of the Roman conquest, and still more decidedly after the Saxon invasions in the fifth century, the history of Britain branches off into a history of the southern part of the island, afterwards known as England, and a history of the northern part of the island, afterwards named Scotland. It was not till the union of the crowns in 1603 that the destinies of England and Scotland began again to unite; and it was not till the final union of the parliaments in 1707 that the histories of the two countries may be said to merge into one. From this latter period accordingly we shall give an outline of the history of the United Kingdom. See also the articles *England*, *Scotland*, and *Ireland*.

The measure which declared the parliaments of England and Scotland united, and the two countries one kingdom, known as the United Kingdom of Great Britain, was passed, after violent opposition, in the reign of Queen Anne, 1st of May, 1707. This union, however much it was opposed by the prejudices and interests of particular men or classes at the time, has contributed very much to the prosperity of both countries. The Grand Alliance, which it had been the aim of William's later years to form between Holland, Austria, and England against the

threatening growth of French power, now held the field against the armies of France, and the victories of Marlborough at Blenheim and Ramillies, and the taking of Gibraltar and Barcelona, ended in the Treaty of Utrecht in 1713, by which the British right of sovereignty over Hudson's Bay, Newfoundland, Nova Scotia, Minorca, and Gibraltar was acknowledged, and the foundation of Britain's imperial and colonial power securely laid. The remainder of Anne's reign was distracted by the never-ending altercations of domestic parties. She died on the 1st of August, 1714; and with her ended the line of the Stuarts, who had held the sceptre of England 112, and that of Scotland 343 years.

At her death George I., elector of Hanover, maternally descended from Elizabeth, daughter of James I., according to the Act of Settlement ascended the throne of Britain. The Whigs under this prince regained that superiority in the national councils of which they had long been deprived, and this, along with the suspension of the Habeas Corpus Act and some other extreme precautionary measures, increased the irritation of the Tory and Stuart party. In 1715 the Earl of Mar in Scotland and the Earl of Derwentwater in England raised the standard of rebellion and proclaimed the Chevalier St. George (the Old Pretender) king. But the insurrection, feebly supported by the people, was soon suppressed. In 1716 the Septennial Act was passed, making parliament of seven instead of three years' duration. In 1720 occurred the extraordinary growth and collapse of the South Sea Company. From this date till 1742 the government was virtually in the hands of Sir Robert Walpole, the first, we might say, of modern premiers, governing the cabinet and chiefly responsible for its doings. Walpole had great sagacity, prudence, and business ability, and could manage dexterously the king, the parliament, and the people alike. It is true that in the case of the parliament he achieved this by undue influence in elections and a scandalous use of bribery. But the power he thus acquired was generally wisely used. The failure of the war with Spain into which he had reluctantly entered drove him from office, and in 1742 his long ministry came to an end. In 1743 George II., frightened at the dangers to Hanover, dragged Britain into the wars between France, Prussia, and Austria, regarding the succession of the Emperor Charles. George

himself fought at the head of his troops at Dettingen (1743), where he obtained a complete victory over the French, which was balanced, however, later on by the defeat at Fontenoy (1745).

A fresh attempt was now made to restore the Stuart family to the throne of Britain. Charles Edward, son of the Old Pretender, having been furnished by France with a small supply of money and arms, landed on the coast of Lochaber, in the Western Highlands, in 1745, and was joined by a considerable number of the people. Marching southwards with 1500 Highlanders, his forces increasing as he advanced, he entered Edinburgh without opposition; and having defeated Sir John Cope near Prestonpans he marched into England. He now took Carlisle, and advanced through Lancaster, Preston, and Manchester, to Derby, within 100 miles of London; but finding himself disappointed of expected succours from France, and the English Tories, contrary to his expectations, keeping aloof, he commenced his retreat into Scotland, closely pursued by the king's troops, whom he again defeated at Falkirk. With this victory his good fortune terminated. The Duke of Cumberland having arrived from the Continent put himself at the head of the forces which were destined to check the rebels; and the armies having met at Culloden, near Inverness, Charles was completely defeated. After lurking for six months amidst the wilds of Inverness-shire, he at length, with much difficulty, escaped to France.

The war of the Austrian succession, which still continued and which was the cause of hostilities between the French and British in India as well as elsewhere, was terminated by the treaty of Aix-la-Chapelle in 1748. During most of this period Pelham and his brother, the Duke of Newcastle, had been the ruling ministers, and in their hands the art of government had reached a low level both as regards morality and ability. In 1752 the *New Style* of reckoning time was introduced, and the *Old Style* being eleven days behind, the 3d of September, 1752, was called the 14th. At the same time the 1st of January was fixed as the opening day of the year, instead of the 25th of March.

Soon after, the French, uneasy at the growing colonial power of Britain, made a determined effort against the British colonies and possessions in North America and

the East Indies, and at first the British met with several disasters in America. In 1756 the Seven Years' War broke out, Austria and France being allied on the one side, and Prussia and England on the other, and ill success attended the British arms in Europe also. Fortunately, a great war minister, William Pitt, now took the helm of state. In 1758 the British made themselves masters of several French settlements in North America, while the attack made by Wolfe on Quebec in 1759 was completely successful, and gave Britain the whole of Canada. The same year the British and their allies defeated the French at Minden in Prussia. In the East Indies the French were even less successful than in America. Clive's victory at Plassey (1757) and Coote's at Wandewash (1760) secured the British empire in the East, and together with the naval feats of Hawke and Boscawen made England the greatest of maritime and colonial powers.

On the accession of George III. in 1760 hostilities were still carried on, generally to the advantage of the French as far as the theatre of war in Germany was concerned, but still more to their loss in the other quarters of the world where they were engaged with the British in a struggle for supremacy, and this notwithstanding that Spain had now joined her forces to those of France. At length the success of the British arms induced France and Spain to accede to terms, and the war ended by the Treaty of Paris in 1763. The French relinquished nearly all their possessions in North America; Minorca was restored to Britain; in the East Indies they got back their factories and settlements, on condition that they should maintain neither forts nor troops in Bengal; Cuba and Manilla were resigned to the Spaniards. In Europe everything was restored to the *status quo*.

The expenses of this war, which had been undertaken partly for the defence of the American colonies, had added upwards of £72,000,000 to the national debt. It seemed to the British people to be just that the Americans should be taxed to assist in payment of the interest. The Americans did not deny the justice, but replied that if they were to be taxed they had a right to be represented in parliament, in order that, like other British subjects, they might be taxed only in consequence of their own consent. Grenville, then the prime-minister, stood to his purpose, however, and intro-

duced a bill for imposing certain stamp duties on the American colonies. The Americans protested and resisted, and partly by the influence of the great Pitt, who had steadily opposed the measure, the bill was withdrawn. On the illness of Pitt, now Lord Chatham, in 1767, Townshend became premier, and again revived the project of taxing the Americans by imposing duties on tea; and in 1770 Lord North, as his successor, set himself to carry it out. The result was that in 1775 America had to be declared in a state of rebellion, and a war began, in which both France and Spain joined the revolted colonies, and of which the result was the recognition of the independence of the United States. On the American side of this struggle the great name is that of George Washington. On the British side the war was unskilfully conducted, and though they gained some successes these were more than counterbalanced by such blows as the capitulation of Burgoyne with nearly 6000 men at Saratoga (1777), and of Cornwallis at Yorktown with 7000 (1781). Against their European foes the British could show such successes as that of Admiral Rodney off Cape St. Vincent (1780); the brilliant defence of Gibraltar by General Elliott (1779-82); and Admiral Rodney's victory over the French fleet in the West Indies (1782). The war closed with the Peace of Versailles in 1783. Britain finally acquired several West Indian islands; Spain got Florida and Minorca, France Pondicherry and Chandernagore in India. The struggle had added over £100,000,000 to the British national debt.

From 1783 to 1801 the government of Britain was directed by William Pitt, the younger son of Lord Chatham, who when only twenty-four years of age was placed as first lord of the treasury and chancellor of the exchequer. The affairs of Ireland and India, and the impeachment of Warren Hastings, were among the first subjects which occupied the attention of Pitt's ministry. In 1782 the Irish had been able to extort from Britain, then engaged in her struggle with the American colonies, the right to establish an independent parliament, so that from this year there were two independent governments in the British Isles till 1800, when Pitt, who had in the interval had some experience of the difficulties arising out of two co-ordinate legislatures, contrived once more to unite them.

In 1789 the French Revolution was

## BRITAIN.

begun. For a time there was considerable sympathy in England with this movement; but as the revolutionaries proceeded to extreme measures there was a reaction in English feeling, of which Edmund Burke became the great exponent, and the execution of Louis XVI. gave rise to diplomatic measures, which finally terminated in the National Convention declaring war against Britain, on 1st February, 1793. At first Britain co-operated with Prussia, Austria, &c., against France, and successes were gained both by sea and land; but latterly on the Continent the armies of the French Republic were everywhere triumphant, and in 1797 Britain stood alone in the conflict, and indeed soon found a European coalition formed against her. The war was now largely maritime, and the naval successes of Jervis off St. Vincent and Duncan off Camperdown were followed, when Bonaparte led an expedition to Egypt, having India as its ultimate object, by the victories of Nelson in Aboukir Bay, and Abercromby at Alexandria. In 1798 a rebellion in Ireland had to be crushed. Peace was made in 1802 by the Treaty of Amiens, only to be broken by another declaration of war in 1803, as the ambitious projects of Napoleon became evident. In spite of the efforts of Pitt (who died in 1806) in the way of forming and supporting with funds a new coalition against France, the military genius of Napoleon swept away all opposition on land, though the naval victory of Trafalgar (1805) established England's supremacy on the seas. Napoleon, who had assumed the title of Emperor of the French in 1805, and was now virtually the ruler of Europe, put forth his Berlin decrees (1807), prohibiting all commerce with Britain wherever his power reached, set his brother Joseph on the throne of Spain, and occupied Portugal. But the spirit of resistance had now taken deep root in the British people, and in 1808 troops were sent into Spain under Sir John Moore, and a year later Wellington, then General Wellesley, landed in Portugal. Then began that famous series of successful operations (the Peninsular War) which drove back the French into their own country, and powerfully contributed to undermine the immense fabric of Napoleon's conquests. The other chief European powers having united, Paris was occupied in 1814, Napoleon was deposed and exiled to Elba, and Louis XVIII. placed on the throne of France. Escaping in 1815, Napoleon ap-

peared once more in the field with a large army. Wellington and Blücher hastened to oppose him, and at Waterloo Napoleon's long career of conquest ended in a crushing defeat. The restoration of Louis followed, and Napoleon was sent to the prison of St. Helena. Of her conquests Britain retained Tobago, St. Lucia, Mauritius, the Cape of Good Hope, Demerara, Essequibo, Berbice, Heligoland, and Malta; Ceylon and Trinidad had been gained in 1802. So that Britain emerged from this long struggle with a very great increase of territorial possessions and political importance.

After the termination of the wars with Napoleon many things concurred to make a troublous era in the home administration. The new burden of debt which the wars had left on the nation, the bad harvests of 1816 and 1817, a succession of governments which had no idea but that of absolute resistance to all reforms, &c.; all these contributed to increase discontent. The result was a strong Radical agitation, accompanied often by serious riots throughout the country, more especially in the large towns, and loud demands for reform in parliament and the system of representation. The death of George III. and accession of George IV. in 1820 made little change in this respect. From 1822 a succession of able statesmen, Canning, Peel, and Lord Grey, gave the government a more liberal turn, and did much to satisfy the popular demands. The Catholics were admitted to parliament; the severity of the old restrictions on commerce was relaxed; and in the face of a determined opposition Earl Grey carried the Reform Bill of 1832 (two years after the accession of William IV.), which gave large manufacturing towns a voting power in some proportion to their importance, and practically transferred the centre of political power from the aristocratic to the middle classes. The next great public measure was the abolition of negro slavery in every British possession in 1834.

William IV. died June 20, 1837, and was succeeded by Victoria. The year following is notable as that in which the Chartists began their movement for reform, which continued more or less active, with popular assemblies, presentations of monster petitions, and occasional tumults, till 1848, when it was without much trouble suppressed. The same years saw the struggle of the Anti-Corn-law League, of which Cobden and Bright were the chiefs, and

which was finally successful; Sir Robert Peel, the leader of the Tory party, himself proposing the repeal of the corn duties (1846). The principle of free-trade had further victories in the repeal of the navigation laws, and in the large abolition of duties made during Lord Aberdeen's ministry (1853).

In 1852-53 dissension arose between Russia and Turkey regarding the rights of the Latin and Greek churches to preferable access to the 'holy places' in Palestine. The Emperor of Russia, resenting concessions made to French devotees, sent Prince Menschikoff to Constantinople to demand redress, and not being satisfied, war was declared, June 26, 1853. On the plea that it was impossible to leave Russia a free hand in dealing with Turkey, France and Britain formed an alliance against Russia, March 28, 1854. The invasion of the Crimea followed; several important battles (Alma, Balaclava, Inkerman) took place, resulting in favour of the allies, till at length Sebastopol fell (1855), and peace was signed the following year at Paris. Russia ceded a part of Bessarabia to Turkey, and consented to the free navigation of the Danube and the neutrality of the Black Sea. (See *Cri-mean War*.)

Scarcely was the Crimean war over when Britain was threatened with the loss of her possessions in India through the mutiny of the Sepoys. For a time the authority of government was entirely suspended throughout the greater part of Bengal, the whole of Oude, and a large portion of Central India; but in a comparatively short time 70,000 British troops, poured in from Burmah, Mauritius, the Cape, and elsewhere, entirely suppressed the rebellion. (See *Indian Mutiny*.) One result of the mutiny was that, by a bill passed Aug. 2, 1858, the sovereignty hitherto exercised over the British possessions in India by the East India Company was transferred to the British crown.

Two wars with China (1858 and 1860), during which Canton was bombarded and Peking taken by united forces of Britain and France, opened up five new Chinese ports to trade, with other advantages. The great civil war in America occurred between 1861 and 1866, and had for a time a disastrous effect on the cotton-trade in Lancashire, causing wide-spread distress. (See *Cotton Famine*.) Between 1861 and 1867 the Fenian movement, which had for its object

the separation of Ireland from the United Kingdom, occasioned some excitement. See *Fenians*.

Parliamentary reform was attempted by several governments without success, until the government of the Earl of Derby in 1867 passed a measure establishing the principle of household suffrage. This year also saw the passing of the act by which the Dominion of Canada was constituted. In 1867 the Abyssinian expedition set out, and effected its object—the relief of English captives in the spring of 1868. In the same year Lord Derby was succeeded by Mr. Disraeli as leader of the Conservative party, then in office. Before the end of the year a general election put the Liberals in power. In 1869 Mr. Gladstone's administration passed a bill for the disestablishment of the Irish Church. In 1870 an Irish Land Law Bill, having for its object the regulation of the relations between landlord and tenant, became law; and during the same session the act of parliament establishing a national system of education for England was passed. In 1871 the purchase of commissions in the army was abolished. Next followed the Ballot Act and the Scotch Education Act. Early in 1874 Mr. Gladstone dissolved Parliament, and a large Conservative majority being returned, Mr. Disraeli (afterwards Earl of Beaconsfield) again became premier. The Ashantee war, begun the previous year, was brought to a successful termination early in 1874. In 1876 the title of Empress of India was added to the titles of the queen. During the Russo-Turkish war of 1877-78 Britain remained neutral, but took an important part in the settlement effected by the Berlin Congress, and acquired from Turkey the right to occupy and administer Cyprus. Then followed a war in Afghanistan, a war with the Kaffres of Zululand, and a brief war with the Boers of the Transvaal.

A new parliament was returned in 1880 with a large Liberal majority, and Mr. Gladstone once more became premier. This parliament passed a land-act for Ireland (1881), an act for putting down crime in Ireland (1882), a reform act equalizing the borough and county franchise (1884), and a redistribution of seats act (1885), both already described. The intervention of Britain in Egyptian affairs led to the bombardment of Alexandria by the British fleet (July, 1882), and the sending of an army into Egypt to quell the rebellion headed by

**Arabi Pasha**, which was soon accomplished; while the rising under the Mahdi in the Soudan caused British troops to be despatched to Suakim, and another force to be sent by way of the Nile (in the autumn of 1884) to relieve General Gordon at Khartoum, an object which it was too late to accomplish. A new parliament was elected in the end of 1885, and for a brief period Lord Salisbury was premier, as he had latterly been in the preceding parliament, but in Feb. 1886, he made way for Mr. Gladstone. On 29th March Mr. Gladstone gave notice of his intention to introduce a bill which, among other things, would establish a separate Irish legislative body, and withdraw the Irish members from the imperial Parliament. A determined opposition was organized, and a section of the Liberal party, headed by men mostly old colleagues of Mr. Gladstone, operated with the Conservatives and succeeded in throwing out the bill on its second reading. The result was the resignation of the Gladstone ministry, and a general election, in which the Unionists, or those opposed to the bill, had a great majority. The Conservative party assumed office, with the Marquis of Salisbury as head. A criminal law amendment act for Ireland (1887), and a local government act for England (1888), were passed. In 1887 the jubilee of the Queen was celebrated. The elections in 1892 resulted in a Liberal victory and Mr. Gladstone became again premier. In 1893 the 'Home Rule' bill urged by Mr. Gladstone, granting to Ireland a separate legislative body with representation in the Imperial Parliament, was passed by the Commons, but defeated in the House of Lords.

**Britannia**, the ancient name of Britain.

**Britannia Metal**, also called **WHITE METAL**, a metallic compound or alloy of tin, with a little copper and antimony, used chiefly for tea-pots, spoons, &c. The general proportions are  $85\frac{1}{2}$  tin,  $10\frac{1}{2}$  antimony, 3 zinc, and 1 copper.

**Britannia Tubular Bridge**, an iron tubular bridge across Menai Strait, which separates Anglesea from Wales, about one mile from the Menai Suspension Bridge. It has two principal spans of 460 feet each over the water, and two smaller ones of 230 feet each over the land; constructed 1846-50. See *Bridge*.

**Britannicus**, son of the Roman Emperor Claudius, by Messalina, born A.D. 42, poisoned A.D. 56. He was passed over by his

father for the son of his new wife Agrippina. This son became the emperor Nero, whose fears that he might be displaced by the natural successor of the late emperor caused him to murder Britannicus.

**British Association FOR THE ADVANCEMENT OF SCIENCE**, a society first organized in 1831, mainly through the exertions of Sir David Brewster, whose object is to assist the progress of discovery, and to disseminate the latest results of scientific research, by bringing together men eminent in all the several departments of science. Its first meeting was held at York, on 26th Sept. 1831, under the presidency of Lord Milton; and all the principal towns of the United Kingdom have on different occasions formed the place of rendezvous, a different locality being chosen every year. The *séances* extend generally over about a week. The society is divided into sections, which, after the president's address, meet separately during the *séances* for the reading of papers and conference. Soirees, conversaciones, lectures, and other general meetings are usually held each evening during the meeting of the Association. As the funds which the society collects at each meeting are more than sufficient to cover its expenses, it is enabled to make money grants for the pursuit of particular scientific inquiries, which otherwise could not be conducted so efficiently, if at all. In 1884 the association held its meeting in Montreal, Canada, the only occasion on which it has met out of the United Kingdom.

**British Channel**. See *English Channel*.

**British Columbia**, a British colony forming with Vancouver Island a province of the Dominion of Canada. It is situated partly between the Rocky Mountains and the sea, partly between Alaska and the meridian of  $120^{\circ}$  w., and extends from the U.S. boundary north to the 60th parallel n. lat. Area, 341,305 sq. miles (including Vancouver Island). Till 1858 it was part of the Hudson Bay Territory; in that year gold discoveries brought settlers, and it became a colony. Vancouver Island, 16,000 sq. miles, became a colony at the same time, but was afterwards joined to British Columbia; the conjoined colony entered the Dominion in 1871. The coast-line is much indented, and is flanked by numerous islands, the Queen Charlotte Islands being the chief after Vancouver. The interior is mountainous, being traversed by the Cascade Mountains near the coast, and by the Rocky Mountains

further west. There are numerous lakes, generally long and narrow, and lying in the deep ravines that form a feature of the surface and are traversed by numerous rivers. Of these the Fraser, with its tributary the Thomson, belongs entirely to the colony, as does also the Skeena; while the upper courses of the Peace River and of the Columbia also belong to it. All except the Peace find their way to the Pacific. Its mountain ranges (highest summits: Mount Hooker, 15,700 feet, and Mount Brown, 16,000 feet) afford magnificent timber (including the Douglas pine and many other trees); and between the ranges are wide grassy prairies. Part of the interior is so dry in summer as to render irrigation necessary, and the arable land is comparatively limited in area, but there is a vast extent of splendid pasture land. The climate is mild in the lower valleys, but severe in the higher levels; it is very healthy. The chief products of the colony are gold, coal, silver, iron, copper, galena, mercury, and other metals; timber, furs, and fish, the last, particularly salmon, being very abundant in the streams and on the coasts. Gold exists almost everywhere, but has been obtained chiefly in the Cariboo district. The total yield since 1858 has been over £10,000,000. The coal is found chiefly in Vancouver Island, and is mined at Nanaimo, where large quantities are now raised. Mining, cattle-rearing, agriculture, fruit-growing, salmon-canning, and lumbering are the chief industries. Victoria, on the s.e. coast of Vancouver Island, is the capital and chief town of the colony. Near Victoria is Esquimalt, a British naval station. New Westminster, on the Fraser River, about 15 miles from its mouth, is the most considerable place on the mainland; but the new town Vancouver, the terminus of the Canadian Pacific Railway, at the mouth of the Fraser, will doubtless become a place of importance. Besides this railway there is one between Nanaimo and Victoria. Steamers now run to China and Japan in connection with the Canadian Pacific Railway, and lines to Australia and India are projected. Like the other provinces of the Dominion, British Columbia has a separate parliament and administration, with a lieutenant-governor of its own. (See *Canada*.) Schools are supported entirely by government. Pop. in 1881, 65,954, including about 25,000 Indians; in 1891, 92,767.

**British Gum.** See *Dextrine*.

**British Honduras.** See *Honduras, British*.

**British Legion, THE,** a corps raised in Britain in 1835, numbering 10,000 men, under the command of General De Lacy Evans, to assist Queen Isabella of Spain in the war with Don Carlos. They did not effect much.

**British Museum,** the great national museum in London, owes its foundation to Sir Hans Sloane, who, in 1753, bequeathed his various collections, including 50,000 books and MSS., to the nation, on the condition of £20,000—less by £30,000 than the original cost—being paid to his heirs. Montague House, which was bought for the purpose for £10,250, was appropriated for the museum, which was first opened on the 15th January, 1759. The original edifice having become inadequate, a new building in Great Russell Street was resolved upon in 1823, the architect being Sir R. Smirke, whose building was not completed till 1847. In 1857 a new library building was completed and opened at a cost of £150,000. It contains a circular reading-room 140 feet in diameter, with a dome 106 feet in height. This room contains accommodation for 300 readers comfortably seated at separate desks, which are provided with all necessary conveniences. More recently, the accommodation having become again inadequate, it was resolved to separate the objects belonging to the natural history department from the rest, and to lodge them in a building by themselves. Accordingly a large natural history museum has been erected at South Kensington, and the specimens pertaining to natural history (including geology and mineralogy) have been transferred thither, but they still form part of the British Museum. Further additions to the Great Russell Street buildings were made in 1882. The British Museum is under the management of 48 trustees. It is open daily, free of charge. Admission to the reading-room as a regular reader is by ticket, procurable on application to the chief librarian, there being certain simple conditions attached. The library, which is now one of the largest and most valuable in the world, has been enriched by numerous bequests and gifts, among others the splendid library collected by George III. during his long reign. A copy of every book, pamphlet, newspaper, piece of music, &c., published anywhere in British territory, must be conveyed free of charge to the British



Museum. The museum contains eight principal departments, namely, the department of printed books, maps, charts, plans, &c.; the department of manuscripts; the department of natural history; the department of oriental antiquities; the department of Greek and Roman antiquities; the department of coins and medals; the department of British and medieval antiquities and ethnography; and the department of prints and drawings.

**British North America**, a name under which are included the Dominion of Canada and the colony of Newfoundland, comprising all the mainland north of the U. States (except Alaska) and a great many islands.

**Brit'tany**, or **BRETAGNE**, an ancient duchy and province of France, corresponding nearly to the modern departments of Finisterre, Côtes du Nord, Morbihan, Ille et Vilaine, Loire Inférieure. It is supposed to have received its name from the Britons who were expelled from England and took refuge here in the fifth century. Along the coast and towards its seaward extremity the country is remarkably rugged, but elsewhere there are many beautiful and fertile tracts. Fisheries employ many of the inhabitants. The people still retain their ancient language, which is closely allied to Welsh, and is exclusively used by the peasantry in the western part of the province.

**Britton**, **JOHN**, an English writer on architectural antiquities, born in 1771, died in 1857. In 1801 appeared the *Beauties of Wiltshire*, in two volumes, by J. Britton and E. W. Brayley. These collaborators, with others, subsequently completed a similar work for all the other counties of England (London, 1801-16, eighteen vols.; 1825, twenty-six vols.; &c.). In 1805 Britton published his *Architectural Antiquities of England* in five 4to volumes, which was followed by his *Cathedral Antiquities*, in fourteen volumes, 1814-35, and *Dictionary of the Architecture and Archæology of the Middle Ages*, 1832-38. A large number of works of a similar character bear his name as joint or sole author or editor.

**Britz'ka**, **Britzs'ka**, a kind of small carriage, the head of which is always a movable calash, and having a place in front for the driver, and a seat behind for servants.

**Brive-la-Gaillarde** (brēv-lā-gā-yārd), a town of South-western France, dep. Corrèze, on the Corrèze, surrounded by fine boulevards planted with elms. Manufactures:

woollens, cottons, candles, brandy, &c. Pop. 9413.

**Brixen**, an old town of Austria, in Tyrol, 104 m. from Vienna by rail, with a cathedral. Pop. 4736.

**Brix'ham**, a seaport and sea-bathing resort, England, Devonshire, on the south of Torbay. Brixham was the place where William III. landed, Nov. 4, 1688. Pop. 7664.

**Bri'za**, a genus of grasses, commonly called quaking grass, maiden's hair, or lady's tresses. There are about thirty species, chiefly found in South America. Two (*B. media* and *B. minor*) are natives of Britain; these and other species are sometimes to be found in gardens as ornamental plants.

**Broach**, or **BAROACH** (brōch, ba-rōch'), town in Guzerat (Gujerat), Hindustan, on the Nerbudda, one of the oldest seaports of Western India, with a considerable coasting trade. The town was taken by storm by the British in 1772, and, with the district, ceded to them by treaty with Scindiah in 1803. Pop. 37,281.

**Broach** (brōch; French *broche*, a spit), a term sometimes applied to a spire that springs directly from a tower, there being no intermediate parapet.

**Broad Arrow**, a government mark placed on British stores of every description (as well as on some other things), to distinguish them as public or crown property, and to obliterate or deface which is felony. Persons in possession of goods marked with the broad arrow forfeit the goods and are subject to a penalty. The origin of the mark is not clearly known.



Broad Arrow.

**Broad'cast**, a mode of sowing grain by which the seed is cast or dispersed upon the ground with the hand or with a machine devised for sowing in this manner; opposed to planting in drills or rows.

**Broad Church**, a name given originally to a party in the Church of England, assuming to be midway between the Low Church or Evangelical section and the High Church or Ritualistic; now widely applied to the more tolerant and liberal section of any denomination.

**Broad Piece**, a name sometimes given to English gold pieces broader than a guinea, particularly Caroluses and Jacobuses.

**Broad'side**, in a naval engagement, the whole discharge of the artillery on one side

of a ship of war. The term is also applied to any large page printed on one side of a sheet of paper, and, strictly, not divided into columns.

**Broad'stairs**, an English watering-place, east coast of Kent, 2 miles N. of Ramsgate. Pop. 2266.

**Broad'sword**, a sword with a broad blade, designed chiefly for cutting, formerly used by some regiments of cavalry and Highland infantry in the British service. The claymore or broadsword was the national weapon of the Highlanders.

**Brocade'**, a stuff of silk, enriched with raised flowers, foliage, or other ornaments. The term is restricted to silks figured in the loom, distinguished from those which are embroidered after being woven. Brocade is in silk what damask is in linen or wool.

**Brocc'oli**, a late variety of the cauliflower, hardier and with more colour in the flower and leaves. The part used is the succulent flower-stalks. Broccoli is inferior in flavour to cauliflower, but serves as a substitute for it when the latter cannot be obtained.

**Broch** (*broh*), a name for certain prehistoric structures in Scotland resembling low, circular, roofless towers with walls of great thickness, built of unhewn stones and without lime or cement, and entered by a narrow passage. There are small chambers in the thickness of the wall accessible only from the interior. These structures were evidently built for defence. They are most numerous in Orkney, Shetland, and the northern counties.

**Brock'en**, the highest summit of the Harz Mountains (3742 feet), in Prussian Saxony, celebrated for the atmospheric conditions which produce the appearance of gigantic spectral figures in the clouds, being shadows of the spectators projected by the morning or evening sun.

**Brockhaus** (*brok'hous*), FRIEDRICH ARNOLD, founder of the eminent German publishing house still carried on by his grandsons, was born 1772, died in 1823. In 1811 he settled at Altenberg, where the first edition of the *Conversations-Lexikon* was completed, 1810–11. The business rapidly extended, and he removed to Leipzig in 1817. There are now chief branches in Berlin and Vienna, and among the literary undertakings of the house have been several important critical periodicals and some large historical and bibliographical works. The *Conversations-Lexikon* distinctively asso-

ciated with the name of Brockhaus has now reached a thirteenth edition.—HERMANN BROCKHAUS, son of F. A. Brockhaus, orientalist, born at Amsterdam 1806, died 1877. From 1848 till his death he was professor of Sanskrit at Leipzig, and published many works on oriental literature. He latterly edited the great *Allgemeine Encyclopädie* of Ersch und Gruber, published now by his father's firm.

**Brockton**, a town of the U. States, Mass., a flourishing place, with large manufactures of boots and shoes, &c. Pop. 27,294.

**Brock'ville**, a town of Canada, prov. of Ontario, on the left bank of the St. Lawrence, about 40 miles below Kingston and 160 above Montreal. It is a station on the Grand Trunk Railway, and has considerable hardware and other manufactures, as steam-engines, chemicals, agricultural implements, &c. Pop. 1891, 8793.

**Brodie**, SIR BENJAMIN COLLINS, BART., D.C.L., F.R.S., an English surgeon, born 1783, died 1862. He was the leading surgeon of his day, and attended George IV., and was serjeant-surgeon to William IV. and to Victoria. He was made a baronet in 1834; from 1858 to 1861 was president of the Royal Society, and was connected with many other scientific and learned societies. He published a number of works all connected with his profession.—His eldest son, SIR BENJAMIN COLLINS BRODIE, a celebrated chemist, was born in London 1817, died 1880. In 1855 he was appointed professor of chemistry at Oxford.

**Bro'dy**, a town in Austrian Galicia, near the Russian frontier, 58 miles E.N.E. of Lemberg. It has 20,071 inhabitants, about two-thirds of whom are Jews. The commerce with Russia and Turkey is important.

**Broglie** (*brol-yē*), a family of Italian origin distinguished in the annals of French wars and diplomacy.—1. FRANÇOIS MARIE, DUC DE, marshal of France, born in 1671, died in 1745; was highly distinguished in the field, and also in diplomacy.—2. VICTOR FRANÇOIS, DUC DE, eldest son of preceding, likewise marshal of France, born in 1718, died 1804; served in Italy, Bohemia, Bavaria, and Flanders. Was minister of war for a short time in 1789, and took part in the invasion of Champagne, 1792.—3. CLAUDE VICTOR, PRINCE DE, born in 1757, guillotined 27th June, 1794, was the third son of Victor François. He entered at first into the views of the revolutionary party, and was appointed field-marshal in the army

of the Rhine, but upon his refusal to acknowledge the decree of the 10th of August suspending the royal authority was deprived of his command, and afterwards summoned before the revolutionary tribunal, and led to the guillotine.—4. **ACHILLE LÉONCE VICTOR CHARLES, DUC DE**, peer of France, son of Claude Victor, born 1785, died 1870. In 1816 he married a daughter of Madame de Staël, and was made a member of the chamber of peers. After the revolution of 1830 the Duc de Broglie and Guizot were the chiefs of the party called *Doctrinaires*. He was minister of public instruction for a short time in 1830, and minister of foreign affairs from Oct. 1832 to April, 1834. In 1849 he was a conservative member of the Legislative Assembly, and after the *coup d'état* he continued a bitter enemy of the imperial régime. His latter years were devoted to philosophical and literary pursuits, and in 1856 he was elected a member of the French Academy.—5. **ALBERT, DUC DE**, son of the preceding, statesman and author, born 1821. His principal work, *The Church and the Roman Empire in the Fourth Century*, has passed through many editions. He has been ambassador at London, minister of foreign affairs, and head of a short-lived royalist ministry in 1877.

**Brogue** (brōg; Ir. and Gael. *brog*), a coarse and light kind of shoe made of raw or half-tanned leather, of one entire piece, and gathered round the foot by a thong, formerly worn in Ireland and the Highlands of Scotland. The term is also used of the mode of pronunciation peculiar to the Irish.

**Broiling**, the cooking of meat or fish on a gridiron above a fire, or by laying it directly on the coals, a very wholesome method of cookery.

**Broke**, **SIR PHILIP BOWES VERE**, a British admiral, born in 1776, died in 1841; distinguished himself, particularly in 1813, as commander of the *Shannon*, in the memorable action which that vessel, in answer to a regular challenge, fought with the U. States vessel *Chesapeake* off the American coast, and in which the latter was captured.

**Broken-wind**, a disease in horses, often accompanied with an enlargement of the lungs and heart, which disables them for bearing fatigue. In this disease the expiration of the air from the lungs occupies double the time that the inspiration of it does; it requires also two efforts rapidly succeeding to each other, attended by a slight spasmodic action, in order fully to

accomplish it. It is caused by rupture of the air-cells, and there is no known cure for it.

**Broker**, an agent who is employed to conclude bargains or transact business for others in consideration of a charge or compensation, which is usually in proportion to the extent or value of the transaction completed by him, and is called *brokerage*. In large mercantile communities the business of each broker is usually limited to a particular class of transactions, and thus there are brokers with several distinctive names, as *bill-brokers*, who buy and sell bills of exchange for others; *insurance-brokers*, who negotiate between underwriters and the owners of vessels and shippers of goods; *ship-brokers*, who are the agents of owners of vessels in chartering them to merchants or procuring freights for them from one port to another; *stock-brokers*, the agents of dealers in shares of joint-stock companies, government securities, and other monetary investments.

**Brokerage**. See above art.

**Brom'berg**, a town of Prussia, province of Posen, on the Brahe, near its confluence with the Vistula. Among its industries are machinery, iron-founding, tanning, paper, tobacco, chicory, pottery, distilling, and brewing. The Bromberg Canal connects the Brahe with the Netz, and thus establishes communication between the Vistula, the Oder, and the Elbe. Pop. 34,064.

**Brome**, **ALEXANDER**, minor English poet and dramatist, born 1620, died 1666. He was the author of many royalist songs and epigrams. Published *The Cunning Lovers*, a comedy, 1654; *Fancy's Festivals*, 1657; *Songs, &c.*, 1660; *Translation of Horace*, 1666.

**Brome**, **RICHARD**, poet and dramatist, died 1652. He wrote *The Jovial Crew*; *The Northern Lass*, and many other plays, ten of which were edited and published by Alexander Brome soon after his death. He was originally a servant of Ben Jonson's, on whose style he endeavoured to mould his own.

**Brome-grass**, the name given to grasses of the genus *Bromus*. Nearly 200 species have been described, occurring both in the Old and the New World. Of these eight are enumerated by British botanists; they are known by having their spikelets many-flowered, two awnless glumes to each floret, two paleæ or valves, the lowermost of which has a rough, straight, rigid awn proceeding

from below the tip of the valve. They are not held in much estimation by the farmer, but an Australian species, *B. Schraderi*, is strongly recommended as a forage plant.

**Bromeliaceæ**, the pine-apple family, a natural order of endogenous plants, taking its name from the genus *Bromelia* (so called after a Swedish botanist, Olaus *Bromel*) to which the pine-apple was once incorrectly referred, and consisting of herbaceous plants remarkable for the hardness and dryness of their gray foliage. They abound in tropical America, commonly growing epiphytically on the branches of trees. With the exception of the pine-apple (*Ananassa sativa*) the Bromeliaceæ are of little value, but some species are cultivated in hot-houses for the beauty of their flowers. They can exist in dry hot air without contact with the earth, and in hot-houses are often kept hung in moist moss.

**Bro'mine** (Gr. *brōmos*, a fetid odour), a non-metallic element discovered in 1826; symbol Br, atomic weight 80. In its general chemical properties it much resembles chlorine and iodine, and is generally associated with them. It exists, but in very minute quantities, in sea-water, in the ashes of marine plants, in animals, and in some salt springs. It is usually extracted from bittern by the agency of chlorine. At common temperatures it is a very dark reddish liquid of a powerful and suffocating odour, and emitting red vapour. It has bleaching powers like chlorine, and is very poisonous. Its density is about four and a half times that of water. It combines with hydrogen to form *hydrobromic acid gas*. With oxygen and hydrogen it forms *bromic acid*.—*Bromide of potassium* (K Br) has sedative and other properties, and is used in medicine (scrofula, goitre, rheumatism, &c.); *bromide of silver* is used in photography.

**Brom'ley**, a town of England, county Kent, 8 miles s.s.e. of London, with a hospital for forty widows of clergymen, and a palace formerly belonging to the Bishop of Rochester. A mineral spring, St. Blaize's Well, has had repute since before the Reformation. Pop. 1891, 21,685.

**Broms'grove**, a town of England, in the county of Worcester, 13 miles s.w. of Birmingham, on the left bank of the Salwarp. Nail-making is the chief industry, there are also chemical works, a cloth-button manufactory, &c. Pop. 1891, 7934.

**Bron'chi** (-kī), the two branches into which the trachea or wind-pipe divides in the chest,

one going to the right lung, the other to the left, and ramifying into innumerable smaller tubes—the *bronchial tubes*.

**Bronchitis** (bron-kī'tis), an inflammation of the mucous membrane of the bronchial

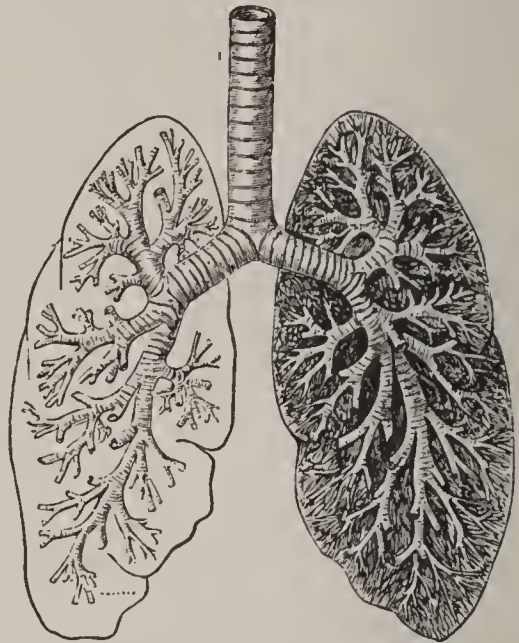

Bronchi and their Ramifications.

tubes, or the air-passages leading from the trachea to the lungs. (See *Bronchi*.) It is of common occurrence, and may be either acute or chronic. Its symptoms are those of a feverish cold, such as headache, lassitude, and an occasional cough, which are succeeded by a more frequent cough occurring in paroxysms, a spit of yellowish mucous, and a feeling of great oppression on the chest. Slight attacks of acute bronchitis are frequent and not very dangerous. They may be treated with mustard poultices or fomentations. Acute bronchitis is often a formidable malady, and requires prompt treatment. Confirmed chronic bronchitis is hardly amenable to medical treatment. Its main symptoms are cough, shortness of breath, and spit. It is particularly apt to attack a person in winter; and in the end may cause death through the lungs becoming unable for their work, and through accompanying complications.

**Bronchocele** (bron'ko-sēl). See *Goitre*.

**Brongniart** (bron-nyär), ALEXANDRE, French geologist and mineralogist, born in 1770, died in 1847. He was appointed in 1800 director of the porcelain manufactory at Sèvres. In 1807 appeared his *Traité Élémentaire de Minéralogie*; and along with Cuvier he wrote *Description Géologique des Environs de Paris*. He also wrote other works on mineralogy and geology, and in

1844 appeared his *Traité des Arts Céramiques*. He was a member of the Academy of Sciences, and in 1822 succeeded Haiiy as professor of mineralogy in the Museum of Natural History. — His son, ADOLPHE THEODORE BRONGNIART, born 1801, died 1876, became professor of botany at the Jardin des Plantes, Paris, 1833; and was the author of several botanical works held in high esteem.

**Bron'te**, a town of Sicily, 22 miles N.N.W. of Catania, in a picturesque situation at the w. base of Mount Etna. Lord Nelson was created Duke of Bronte by the Neapolitan government in 1799. Pop. 14,567.

**Bron'të**, CHARLOTTE (afterwards MRS. NICHOLLS), English novelist, born at Thornton, in Yorkshire, 21st April, 1816; died at Haworth, 31st March, 1855. She was the third daughter of the Rev. Patrick Brontë, rector of Thornton, from which he removed in 1820, on becoming incumbent of Haworth, a moorland village in the West Riding of Yorkshire, about 4 miles from Keighley. Her mother died soon after this removal, and her father, an able though eccentric man, brought up Charlotte and her sisters in quite a Spartan fashion, inuring them to every kind of industry and fatigue. After an education received partly at home and partly at neighbouring schools, Miss Brontë became a teacher, and then a governess in a family. In 1842 she went with her sister Emily to Brussels, with the view of acquiring a knowledge of the French and German languages, and she subsequently taught for a year in the school she had attended here. In 1844 arrangements were entered into by her and her sisters Charlotte and Emily to open a school at Haworth, but from the want of success in obtaining pupils no progress was ever made with their scheme. They resolved now to turn their attention to literary composition; and in 1846 a volume of poems by the three sisters was published, under the names of Currer, Ellis, and Acton Bell. It was issued at their own risk, and attracted little attention, so they quitted poetry for prose fiction, and produced each a novel. Charlotte (Currer Bell) entitled her production *The Professor*, but it was everywhere refused by the publishing trade, and was not given to the world till after her death. Emily (Ellis Bell) with her tale of *Wuthering Heights*, and Anne (Acton Bell) with *Agnes Grey*, were more successful. Charlotte's failure, however, did not discourage her, and she composed the

novel of *Jane Eyre*, which was published in October, 1847. Its success was immediate and decided. Her second novel of *Shirley* appeared in 1849. Previous to this she had lost her two sisters, Emily dying on 19th Dec. 1848, and Anne on 28th May, 1849 (after publishing a second novel, the *Tenant of Wildfell Hall*). In the autumn of 1852 appeared Charlotte's third novel, *Villette*. Shortly after, she married her father's curate, the Rev. Arthur Bell Nicholls, but in nine months died of consumption. Her originally rejected tale of *The Professor* was published after her death, in 1857, and the same year a biography of her appeared from the pen of Mrs. Gaskell.

**Brontosau'rus**, a gigantic reptilian animal, of the order Dinosauria, found fossil in secondary strata of the Rocky Mountains, having a long neck and tail, a very small head, and strong limbs.

**Bronx**, BOROUGH OF, Greater N. York, that portion of the city above the Harlem river and Woodlawn.

**Bronze** is an alloy of copper and tin, to which other metallic substances are sometimes added, especially zinc. It is a fine-grained metal, taking a smooth and polished surface, harder and more fusible than copper, but not so malleable. In various parts of the world weapons and implements were made of this alloy before iron came into use, and hence the *bronze age* is regarded as one coming between the *stone age* and the *iron age* of prehistoric archæology. (See *Archæology*.) Both in ancient and modern times it has been much used in making casts of all kinds, medals, bas-reliefs, statues, and other works of art; and varieties of it are also used for bells, gongs, reflectors of telescopes, cannon, &c. Its colour is reddish, brownish, or olive-green, and is darkened by exposure to the atmosphere. Ancient bronze generally contains from 4 to 15 per cent of tin. The alloy of the present British bronze coinage consists of 94 parts of copper, 4 of tin, and 1 of zinc. An alloy of about 85 parts copper, 11 zinc, and 4 tin is used for statues. Bell-metal consists of 78 of copper and 22 of tin. An alloy called *phosphor bronze*, consisting of about 90 per cent of copper, 9 of tin, and from .5 to .75 of phosphorus has been found to have peculiar advantages for certain purposes. The addition of phosphorus increases the homogeneity of the compound, and by varying the proportion of the constituents the hardness, tenacity, and elasticity of the alloy may be

modified at pleasure.—*Aluminium bronze* is an alloy of copper and aluminium, the metals being combined in different proportions according to the kind of bronze wanted. One variety is of a yellow or golden colour, and is made into watch-chains and ornamental articles.—*Manganese bronze* is a bronze containing manganese and iron, and is said to possess remarkable properties in regard to strength, hardness, toughness, &c.—*Bronzing* is the operation of covering articles with a wash or coating to give them the appearance of bronze. Two kinds are common, the yellow and the red. The yellow is made of fine copper dust, the red of copper dust with a little pulverized red ochre. The fine green tint which bronze acquires by oxidization, called *patina antiqua*, is imitated by an application of sal-ammoniac and salt of sorrel dissolved in vinegar. Recently bronze has been deposited on small statues and other articles with good effect by means of the electrotype process.

**Bronze Age.** See *Bronze*.

**Bronze-wing**, a name for certain species of Australian pigeons, chiefly of the genus *Phaps*, distinguished by the bronze colour of their plumage. The common bronze-winged ground-dove (*P. chalcoptera*) abounds in all the Australian colonies, and is a plump bird, often weighing a pound, much esteemed for table.

**Bronzing.** See *Bronze*.

**Brooch** (brōch), a kind of ornament worn on the dress, to which it is attached by a pin stuck through the fabric. They are usually of gold or silver, often worked in highly artistic patterns and set with precious stones. Brooches are of great antiquity, and were formerly worn by men as well as women, especially among the Celtic races. Among the Highlanders of Scotland there are preserved in several families ancient brooches of rich workmanship and highly ornamented. Some of them seem to have been used as a sort of amulet or talisman.

**Brooke**, HENRY, dramatist and novelist, the son of an Irish clergyman, was born in 1703, died 1783. He was educated at Dublin University, and numbered Swift, Pope, and Garrick among his friends. In 1745 he was made barrack-master at Mullingar, and spent the rest of his life in literary work. He wrote many plays and novels, his chief novel being *The Fool of Quality*.

**Brooke**, SIR JAMES, celebrated as the Rajah of Sarawak, was born in Bengal in

1803, and died in Devonshire 1868. In 1838, having gone to Borneo, he assisted the Sultan of Brunei (the nominal ruler of the island) in suppressing a revolt. For his services he was made Rajah and Governor of Sarawak, a district on the N.W. coast of the island, and being established in the government he endeavoured to induce the Dyak natives to abandon their irregular and piratical mode of life and to turn themselves to agriculture and commerce; and his efforts to introduce civilization were crowned with wonderful success. He was made a K.C.B. in 1847, and was appointed Governor of Labuan.

**Brookhaven**, Suffolk Co., Long Island N. Y., 58 miles E. of Brooklyn; a congregation of villages. Pop. 1890, 12,572.

**Brooklime** (*Veronica Beccabunga*), a European plant, with blue flowers, common in ditches and wet places in Britain, a species of speedwell. It is sometimes used in salads.

**Brookline**, a town of the U. States, forming a suburb of Boston. Pop. 1890, 12,103.

**Brooklyn**. Since Jan. 1, 1898, a portion of the city of Greater New York, on the west end of Long Island, separated from Manhattan by East River, a strait about three-quarters of a mile broad, crossed by steam-ferries, and by a suspension-bridge 5989 feet long and 135 feet high. Brooklyn is one of the finest cities in the United States, with broad, straight streets, many of them planted with rows of trees. It has a river-front of nearly 9 miles, and covers an area of 16,000 acres. It is popularly known as the 'city of churches,' having about 300 of all denominations. Among the public buildings are the city hall, of white marble, the jail, the county court-house, the academy of music, &c. The literary and charitable institutions are very numerous. The Atlantic Dock is one of the largest in the States, covering 40 acres. The United States navy-yard, on Wallabout Bay, occupies 45 acres. Brooklyn is a favourite residence of the wealthy New Yorkers. It has a large trade. It was founded in 1625, and was the scene of several memorable events of the revolution. Pop. 1892, 955,810.

**Brooks**, CHARLES SHIRLEY, English novelist and journalist, born 1815, died 1874. He wrote many plays and novels.

**Brooks**, PHILLIPS, Bishop, was born in Boston, Mass., in 1835. He was one of the most widely known and celebrated clergymen of the American Protestant Episcopal Church. In England he received honorary degrees from both Oxford and Cambridge

In 1892 he was elected Bishop of Massachusetts Diocese. He died Jan. 23, 1893.

**Broom**, a popular name which includes several allied genera of plants of the natural order Leguminosæ and of the sub-order Papilionaceæ, plants distinguished by a leguminous fruit and papilionaceous flowers. The common broom of Europe (*Cytisus scoparius*) is a bushy shrub with straight angular branches, of a dark-green colour, deciduous leaves, and flowers of a deep golden yellow. Its twigs are often made into brooms, and are used as thatch for houses and corn-stacks. They have also been used for tanning. The whole plant has a very bitter taste, and a decoction of it is diuretic, in strong doses emetic.—*White broom* or *Portugal broom* (*C. albus*) has beautiful white flowers.—*Spanish Broom* or *Spart* (*Spartium junceum*) is an ornamental flowering shrub growing in Africa, Spain, Italy, and the s. of France, and often cultivated in English gardens. It has upright, round branches, that flower at the top, and spear-shaped leaves. Its fibre is made into various textile fabrics, and is also used in paper-making.—*Dyer's Broom* (*Genista tinctoria*) yields a yellow colour used in dyeing.—*Butcher's broom* is *Ruscus aculeatus*, an evergreen shrub of the order Liliaceæ, and therefore entirely different from the brooms proper.

**Broom-corn, Broom-grass** (*Sorghum vulgare*, millet or Guinea-corn), a plant of the order of grasses, with a jointed stem, rising to the height of 8 or 10 feet, extensively cultivated in N. America, where the branched panicles are made into carpet-brooms and clothes-brushes. The seed is used for feeding poultry, cattle, &c.

**Brother Jonathan**, meaning the people of the United States, as 'John Bull,' the people of England. Washington, on assuming command of the New England revolutionary forces, was in great straits for arms and war material. The governor of Connecticut, Jonathan Trumbull, was a man of excellent judgment and an esteemed friend of Washington. In the emergency Washington said 'we must consult Brother Jonathan.' This expression was repeated on other difficult occasions, and became a convenient name for the whole people.

**Brothers**, a term applied to the members of monastic and military orders as being united in one family. *Lay brothers* were an inferior class of monks employed in monasteries as servants. Though not in holy orders, they were bound by monastic rules.

**Brothers, RICHARD**, English fanatic and self-styled prophet, born about 1760, died in 1824. He served as a lieutenant in the army, which he quitted in 1789, refusing from conscientious scruples to take the oath necessary to entitle him to his half-pay. He announced himself in 1793 as the apostle of a new religion, dating his call from 1790. He styled himself the 'Nephew of the Almighty, and Prince of the Hebrews, appointed to lead them to the land of Canaan.' He published in 1794 *A Revealed Knowledge of the Prophecies and Times*, in two books. He was committed to Newgate for prophesying the death of the king, and subsequently to Bedlam as a dangerous lunatic, but was released in 1806.

**Brougham** (bröm or brō'ém), a close four-wheeled carriage, with a single inside seat for two persons, glazed in front and with a raised driver's seat, named after and apparently invented by Lord Brougham.

**Brougham** (bröm or brō'ém), HENRY, BARON BROUGHAM AND VAUX, was born at Edinburgh 19th September, 1778; died at Cannes 7th May, 1868. He was educated at Edinburgh, studied law there, and was



Lord Brougham.

admitted a member of the Society of Advocates in 1800. Along with Jeffrey, Horner, and Sydney Smith he bore a chief part in the starting of the *Edinburgh Review* in 1802, to which he contributed a great number of articles. Finding too circumscribed a field for his abilities in Edinburgh he removed to

London, and in 1808 was called to the English bar. In 1810 he entered parliament as member for the borough of Camelford, joined the Whig party, which was in opposition, and soon after obtained the passing of a measure making the slave-trade felony. From 1812 until 1816 he remained without a seat, when he was returned for Winchelsea. He represented this borough up to 1830. On his return to parliament he at once began an agitation for social, political, and especially educational reform. In 1825 he was elected Lord Rector of Glasgow University, and also introduced a bill into parliament for the incorporation of the London University, of which he may be considered one of the chief founders. He also bore an active part in establishing the Society for the Diffusion of Useful Knowledge in 1827. Meantime his reputation as a brilliant speaker and able barrister had been gradually increasing, and his fearless and successful defence of Queen Caroline in 1820 and 1821 placed him on the pinnacle of popular favour. At the general election of 1830 he was returned for the large and important county of York. In the ministry of Earl Grey he accepted the post of lord-chancellor, and was raised to the peerage (22d Nov. 1830) with the title of Baron Brougham and Vaux. In this post he distinguished himself as a law reformer, and aided greatly in the passing of the Reform Bill of 1832. In 1834 the Whig ministry were dismissed, and this proved the end of his official life, as he was never afterwards a member of any ministry, though for years he continued an active member of the House of Lords. In connection with his later years we may mention his presidency of the Law Amendment Society and of the Social Science Association. In legal procedure he was the means of introducing various reforms. He latterly resided much at Cannes. Lord Brougham accomplished a large amount of literary work, contributing to newspapers, reviews, and encyclopedias, besides writing several independent works; and he had no mean reputation in mathematics and physical science. His works, collected by himself, and published in eleven vols. (1857-60), include: 1st, Lives of Men of Science, time of George III.; 2d, Lives of Men of Letters, time of George III.; 3d, 4th, British Statesmen, time of George III.; 5th, Foreign Statesmen, time of George III.; 6th, Natural Theology; 7th, Rhetorical and Literary Dissertations and Addresses; 8th, Rhetori-

cal and Political Dissertations; 9th and 10th, Speeches on Social and Political Subjects; 11th, The British Constitution. He also wrote an autobiography published posthumously under the title: Life and Times of Henry, Lord Brougham.

**Brougham**, JOHN, actor and dramatist; born in Dublin 1810; died in New York 1880. He wrote upwards of a hundred pieces, including *The Game of Life*, *Romance and Reality*, *Love's Livery*, *The Duke's Motto*, &c., and contributed largely to periodicals. He was well known as an actor both in England and in America.

**Broughton** (brə'tun), JOHN CAM HOBHOUSE, LORD, English writer and statesman; born 1786, died 1869. He was the son of Sir Benjamin Hobhouse, and was an intimate friend of Lord Byron, whom he accompanied in his travels to Greece and Turkey in 1809. He published in 1812 *Journey into Albania and other Provinces of the Turkish Empire*. He also accompanied Byron to Italy in 1816-17, and wrote *Historical Illustrations of the Fourth Canto of Childe Harold*. In 1816 he published *Letters on the Hundred Days, or Last Reign of Napoleon*. He entered parliament in 1819 as member for Westminster. In 1832 he entered Lord Melbourne's ministry as secretary at war, and became a privy-councillor. In 1833 he was made chief-secretary for Ireland, and in 1835 he was appointed president of the board of control. He held this office till Sept. 1841, and in Lord Russell's administration, 1846-52. He was raised to the peerage as Baron Broughton in 1851.

**Broughty-Ferry** (brə'ti), a town of Scotland, county Forfar, N. shore of the estuary of the Tay, 3 miles E. Dundee, so called from a ferry across the Tay to Ferry-port-on-Craig, in Fifeshire. Here are many mansions belonging to the merchants and manufacturers of Dundee, and at the east end of the town the old castle of Broughty, with guns, &c., for the defence of the Tay. Pop. 7407.

**Broussa** (brös'ä). See *Brusa*.

**Broussais** (brö-sä), FRANÇOIS JOSEPH VICTOR, French physician, born 1772, died 1838. He is regarded as the founder of what was called the physiological system of medicine. According to his theory irritability was the fundamental property of all living animal tissues, and every malady proceeded from an undue increase or diminution of that property.



**Broussonet** (brö-so-nā), PIERRE MARIE AUGUSTE, French naturalist, born 1761, died 1807. He lived for some time in England, and was a friend of Sir Joseph Banks. He published *Ichthyologia*, and *Memoirs towards the History of the Respiration of Fishes*. He was professor of botany at Montpellier, and a member of the Academy of Sciences.

**Broussonetia** (brö-so-nē'ti-a), a genus of trees, nat. ord. Moraceæ, or mulberries, the paper-mulberry. See *Mulberry*.

**Brouwer** (brou'ver), or BRAUWER, ADRIAAN, a Dutch painter, born in 1608, died in 1640. He was a pupil of Franz Hals, and was patronized by Rubens; but was of very dissipated habits. His works are chiefly tavern scenes and other delineations of low life, and rank among the best of their kind.

**Brown**, a colour which may be regarded as a mixture of red and black, or of red, black, and yellow. There are various brown pigments, mostly of mineral origin, as bistre, umber, cappagh brown, &c.

**Brown**, CHARLES BROCKDEN, an eminent American novelist, was born in Philadelphia in 1771, died 1810. He was destined for the law, but the term intended for preparatory legal study was principally occupied with literary pursuits. His novel *Wieland, or the Transformation*, was published in 1798; *Ormond, or the Secret Witness*, in 1799; and *Arthur Mervyn* in 1800. In the last-named work the ravages of the yellow fever, which the author had witnessed in New York and Philadelphia, are painted with terrific truth. He was originator of the *Monthly Magazine and American Review* (1799-1800). He also founded in 1805 the *Literary Magazine and American Register*, which he edited for five years. Among his other works are *Clara Howard* (1801) and *Jane Talbot* (1804).

**Brown**, FORD MADOX, English painter, grandson of Dr. John Brown of Edinburgh, the author of the Brunonian system of medicine, was born at Calais, 1821. In 1844 and 1845 he contributed (unsuccessfully) cartoons of the Finding of the Body of Harold; Justice; and other subjects to the competitive exhibition for the frescoes of the houses of parliament. Among his principal works are: *King Lear*; *Chaucer at the Court of Edward III.*; *The Last of England*; *Work*; *Cordelia's Portion*; the Manchester town-hall frescoes, &c. He is generally rated as a pre-Raphaelite, but though a close inti-

macy existed between him and the brotherhood, he never actually joined them.—His son, OLIVER MADOX BROWN (born 1855, died 1874), from early boyhood showed remarkable capacity both in painting and literature, especially prose fiction and poetry. His *Literary Remains* were published in 1876.

**Brown**, GEORGE, Canadian journalist and politician, born in Edinburgh, Scotland, 1818, and educated at the High School there. He emigrated to the United States with his father, and assisted in the management of a



George Brown.

newspaper at New York; but in 1843 removed to Toronto, Canada, where he founded a newspaper, *The Globe*, which was very successful. In 1852 he was returned to parliament, and rapidly rose to the first rank as a debater and advocate of reforms. In 1858 he was called to the office of premier, and formed an administration, which, however, owing to an adverse vote of the assembly, lasted only three days. In 1862, while on a visit to Scotland, he married Miss Annie Nelson, daughter of the well-known Edinburgh publisher. On his return to Canada he joined, in 1864, the coalition government as leader of the reform section, and took an active part in the conferences held at Charlottetown and Quebec on the subject of the federation of the North American colonies; but resigned his office as minister in Dec. 1865. He was called to the senate in 1873, and the year after went to Washington along with Sir Edward Thornton to negotiate a commercial treaty with the United States. He died on 9 May, 1880, of a gunshot wound inflicted by a discharged employee. Mr. Brown, though perhaps wanting in some of the qualities which make a successful parliamentary leader, was a

great personal force in Canadian politics, and contributed powerfully to the cause of reform.

**Brown, SIR GEORGE**, distinguished British general, born near Elgin 1790, died 1865; served in the Peninsular war, and in the American campaign of 1814. He became lieutenant-general in 1851; and distinguished himself in the Crimean war at Alma, Inkerman, and Sebastopol. Was made K.C.B. in 1855.

**Brown, JOHN**, Scottish covenanting martyr, born about 1627, killed 1685. He is said to have fought against the government at Bothwell Bridge in 1679, and to have been on intimate terms with the leaders of the persecuted party. He was shot by Claverhouse and a party of his dragoons at Priestfield or Priesthill in the upland parish of Muirkirk, Ayrshire, where he cultivated a small piece of ground and acted as a carrier.

**Brown, JOHN**, Scottish divine, minister in the Burgher dissenting body at Haddington, born in 1722, died 1787. By intense application to study he became acquainted with the French, Italian, German, Arabic, Persian, Syriac, and Ethiopic languages, as well as the Greek and Hebrew. His most important works are: *The Self-interpreting Bible*; *Dictionary of the Bible*; *Explication of the Assembly's Catechism*; *The Christian Journal*; *Explication of Scripture Metaphors*; *System of Divinity*; *General History of the Church*; *Particular History of the Churches of England, Scotland, and Ireland*; and *Harmony of Scripture Prophecies*.

**Brown, JOHN, M.D.**, author of the Brunonian system in medicine, was born in Berwickshire 1735, died in London 1788. After studying medicine at the Edinburgh University he took the degree of Doctor in Medicine at St. Andrew's, and after practising and teaching in Edinburgh he published his *Elements of Medicine* (in Latin). He maintained that the majority of diseases were proofs of weakness and not of excessive strength or excitement, and therefore contended that indiscriminate lowering of the system, as by bleeding, was erroneous, and that supporting treatment was required. His system gave rise to much opposition, but his opinions materially influenced the practice of his professional successors. Having fallen into difficulties, he removed to London in 1786.

**Brown, JOHN, D.D.**, Scottish divine,

grandson of the Rev. John Brown of Haddington, born 1784, died 1858. He was ordained pastor of the Burgher congregation at Biggar in 1806. In 1821 he removed to Edinburgh; and in 1834 became professor of theology in connection with the body to which he belonged, afterwards merged in the United Presbyterian Church. He was author of numerous works chiefly in Biblical criticism, some of which were very popular.

**Brown, JOHN**, an American opponent of slavery, born 1800, hanged 1859. He early conceived a hatred for slavery, and having removed to Osawatomie, Kansas, in 1855, he took an active part against the pro-slavery party, the slavery question there giving rise already almost to a civil war. In the summer of 1859 he rented a farmhouse about six miles from Harper's Ferry, and organized a plot to liberate the slaves of Virginia. On Oct. 16 he, with the aid of about twenty friends, surprised and captured the arsenal at Harper's Ferry, but was wounded and taken prisoner by the Virginia militia next day, tried, and executed at Charlestown, 2d Dec.

**Brown, JOHN**, physician and essayist, son of John Brown, D.D., born at Biggar 1810, died at Edinburgh 1882. He graduated M.D. in 1833 and began practice as a physician. His leisure hours were devoted to literature, many of his contributions appearing in the *North British Review*, *Good Words*, and other periodicals. His collected writings were published under the title of *Horæ Subsecivæ* (leisure hours), and embrace papers bearing on medicine, art, poetry, and human life generally. Several of his sketches (such as *Rab* and his *Friends*, *Our Dogs*, *Pet Marjory*, *Jeems the Doorkeeper*) on which his fame chiefly rests, have been published separately. Humour, tenderness, and pathos are his chief characteristics.

**Brown (or BROWNE), ROBERT**, founder of an English religious sect first called *Brownists*, and afterwards *Independents*, was born about 1540, and studied at Cambridge, where, in 1580, he began openly to attack the government and liturgy of the Church of England as anti-Christian. After attacking the Established Church for years he was excommunicated, but was reinstated, and held a church living for over forty years, dying in 1633. The sect of Brownists, far from expiring with their founder, soon spread, and a bill was brought into parliament which inflicted on them very severe pains and penalties. In process of time,

however, the name of Brownists was merged in that of Congregationalists or Independents.

**Brown, ROBERT**, botanist, born at Montrose, 21st December, 1773; died in London 10th June, 1858; was the son of a Scotch Episcopalian clergyman. He received his education at Marischal College, Aberdeen, and afterwards studied medicine at Edinburgh. In 1800 he was appointed naturalist to Flinders' surveying expedition to Australia. He returned with nearly 4000 species of plants, and was shortly after appointed librarian to the Linnæan Society. In 1810 he published the first volume of his great work *Prodromus Floræ Novæ Hollandiæ et Insulæ Van Diemen*. No second volume of it ever appeared. He was the first English writer on botany who adopted the natural system of classification, which has since entirely superseded that of Linnæus. In 1814 he published a botanical appendix to Flinders' account of his voyage, and in 1828 *A Brief Account of Microscopical Observations on the Particles contained in the Pollen of Plants, and on the General Existence of Active Molecules in Organic and Inorganic Bodies*. He also wrote botanical appendixes for the voyages of Ross and Parry, the African exploration of Denham and Clapperton and others, and described, with Dr. Bennet, the plants collected by Dr. Horsfield in Java. In 1810 he received the charge of the collections and library of Sir Joseph Banks. He transferred them in 1827 to the British Museum, and was appointed keeper of botany in that institution. He became a fellow of the Royal Society in 1811, D.C.L. Oxford in 1832, a foreign associate of the French Academy of Sciences in 1833. He had the Copley medal in 1839, and was appointed president of the Linnæan Society in 1849. As a naturalist Brown occupied the very highest rank among men of science. A collection of his miscellaneous writings has been published by the Ray Society (1866-67).

**Brown, THOMAS**, poet and miscellaneous writer, described by Addison as 'of facetious memory,' born at Shifnal, Shropshire, 1663, died in London 1704. He is the author of numerous dialogues, letters, poems, &c., witty, coarse, and indelicate, first collected in 1707.

**Brown, DR. THOMAS**, Scotch metaphysician, was born at Kirkmabreck, Kirkcudbright, in 1778; died at Brompton, London, 1820. He was educated at the High School, and

subsequently at the University of Edinburgh, where he obtained the professorship of moral philosophy. He distinguished himself, at a very early age, by an acute review of the medical and physiological theories of Dr. Darwin, in a work entitled *Observations on Darwin's Zoonomia*. He published some indifferent poems which were collected in 1820. But he chiefly deserves notice on account of his metaphysical speculations, his chief work being *Lectures on the Philosophy of the Human Mind*, 1822. His system reduces the intellectual faculties to three great classes—perception, simple suggestion, and relative suggestion; employing the term suggestion as nearly synonymous with association. He held original views in regard to the part played by touch and the muscular sense in relation to belief in an external world. His development of the theory of cause and effect was first suggested by Hume.

**Brown Bess**, a name familiarly given to the old government regulation bronzed flintlock musket formerly used in the British army.

**Brown Bread**. See *Bread*.

**Brown Coal**, a variety of *Lignite* (which see).

**Browne, CHARLES FARRAR**, an American humorist, best known as 'Artemus Ward,' was born at Waterford, Maine, 1834; died at Southampton, England, 1867. Originally a printer, he became editor of papers in Ohio, where his humorous letters became very popular. He subsequently lectured on California and Utah in the States and in England, where he contributed to *Punch*. His writings consist of letters and papers by 'Artemus Ward,' a pretended exhibitor of wax figures and wild beasts, and are full of drollery and eccentricity.

**Browne, HABLOT KNIGHT**, an English designer of humorous and satirical subjects, and an etcher of considerable skill, better known by the pseudonym of 'Phiz,' born at Kennington, Surrey, 1815, died at Brighton 1882. In 1835 he succeeded Seymour as the illustrator of Dickens's *Pickwick*, and was afterwards engaged to illustrate *Nicholas Nickleby*, *Dombey & Son*, *Martin Chuzzlewit*, *David Copperfield*, and other works of that author. He also illustrated the novels of *Lever*, *Ainsworth*, &c., besides sending many comic sketches to the illustrated serials of the time.

**Browne, ISAAC HAWKINS**, English poet, born at Burton-on-Trent 1706, died 1760.

Author of *Design and Beauty*; *The Pipe of Tobacco* (in which he imitates Pope, Young, Swift, and others); and a Latin Poem, *De Animi Immortalitate*, modelled on Lucretius and Virgil.

**Browne**, SIR THOMAS, an English physician and writer, was born in London 1605, died at Norwich 1682. He was educated at Winchester School and Oxford, where he took the degree of M.A. He practised as a physician for some time in Oxfordshire. He subsequently visited the continent of Europe and received the degree of M.D. at Leyden. On his return to England he settled as a physician at Norwich, where he married and acquired extensive practice and reputation. In 1642 was published his *Religio Medici* (a Physician's Religion), which excited the attention of the learned, not only in England but throughout Europe, gave rise to doubts of the author's orthodoxy, and was translated into various languages. In 1646 his literary reputation was still further heightened by the appearance of his *Pseudodoxia Epidemica*, or *Treatise on Vulgar Errors*, a work of extraordinary learning, and accounted the most solid and useful of his literary labours. In 1658 his *Hydriotaphia*, or *Treatise on Urn-Burial*, appeared conjointly with his *Garden of Cyrus*, a work treating of horticulture from Adam's time to that of Cyrus. These works ranked him very high as an antiquary; and he maintained a wide correspondence with the learned both at home and abroad. In 1665 he was constituted an honorary member of the College of Physicians, and in 1671 Charles II., visiting Norwich, conferred on him the honour of knighthood. Of a most amiable private character, he was happy in the affection of his large family and numerous friends; and passed through a remarkably tranquil and prosperous literary and professional life. Though he wrote exposing vulgar errors he was himself a believer in alchemy, astrology, and witchcraft.

**Browne**, WILLIAM, an English poet, born at Tavistock in Devonshire in 1591, died about 1645. In his twenty-third year he published his *Britannia's Pastorals*, which met with great approbation; and in the following year appeared his *Shepherd's Pipe*, in seven eclogues. In 1616 he published the second part of his *Britannia's Pastorals*, which met with equal success with the former. Browne was tutor to Robert Dormer, earl of Caernarvon, who was killed at the battle of Newbury, and filled a similar

office in the family of the Earl of Pembroke.

**Browne**, WILLIAM G., English traveller, in Africa and Asia; born in London 1768; killed by robbers in Persia 1813. He visited the African kingdoms of Darfur and Bornou in 1791, and was the first who made those countries known to Europeans. He published in 1799 *Travels in Africa, Egypt, and Assyria*, from 1792 to 1798.

**Brown Holland**, an unbleached linen used for various articles of clothing and upholstery.

**Brownie**, in Scotland, an imaginary spirit formerly believed to haunt houses, particularly farmhouses. Instead of doing any injury he was believed to be very useful to the family, particularly to the servants if they treated him well, for whom he was wont to do many pieces of drudgery while they slept. The brownie bears a close resemblance to the Robin Goodfellow of England, and the *Kobold* of Germany.

**Browning**, ELIZABETH BARRETT, English poetess; born at Burn Hall, Durham, in 1809; died at Florence 1861. Her father, Edward Moulton, took the name of Barrett on succeeding to some property. She grew up at Hope End, near Ledbury, Herefordshire, where her father possessed a large estate. Her bodily frame was from the first extremely delicate, and she had been injured by a fall from her pony when a girl, but her mind was sound and vigorous, and disciplined by a course of severe and exalted study. She early began to commit her thoughts to writing, and in 1826 a volume, entitled *An Essay on Mind*, with other Poems, appeared of her authorship. A money catastrophe compelled her father to settle in London, and her continued delicacy received a severe shock by the accidental drowning of her brother, causing her to pass years in the confinement of a sick-room. Her health was at length partially restored, and in 1846 she was married to Mr. Robert Browning, soon after which they settled in Italy, and continued to reside for the most part in the city of Florence. Her *Prometheus Bound* (from the Greek of Æschylus) and *Miscellaneous Poems* appeared in 1833; the *Seraphim* and other Poems in 1838. In 1856 a collected edition of Mrs. Browning's works appeared, including several new poems, and among others *Lady Geraldine's Courtship*. *Casa Guidi Windows*, a poem on the struggles of the Italians for liberty in 1848-49, appeared in

1851. The longest and most finished of all her works, *Aurora Leigh*, a narrative and didactic poem in nine books, was published in 1857. *Poems before Congress*, appeared in 1860, and two posthumous volumes: *Last Poems*, 1862, and *The Greek Christian Poets and the English Poets* (prose essays and translations), 1863, were edited by her husband.

**Browning**, ROBERT, poet, born at Camberwell, Surrey, 1812; died Dec. 12, 1889. He was educated at University College, London, after which he went to Italy, where he made diligent study of its mediæval history and the life of the people. In 1846 he married Elizabeth Barrett (see above), and has since resided chiefly in Italy, making occasional visits to England. His first poem, *Pauline*, was published in 1833; followed by *Paracelsus* in 1835; *Stafford*, a Tragedy (1837), produced at Covent Garden, Macready and Helen Faucit playing the chief parts. *Sordello* appeared in 1840, followed by the series called *Bells and Pomegranates*, including the three plays *Pippa Passes*, *King Victor and King Charles*, and *Colombe's Birthday*; four tragedies: *The Return of the Druses*, *A Blot on the Scutcheon*, *Luria*, and *The Soul's Tragedy*; and a number of Dramatic Lyrics, among them the well-known *Pied Piper of Hamelin*, and *How they Brought the Good News from Ghent to Aix* (1841-46). Between 1846 and 1868 appeared *Men and Women*; *Christmas Eve and Easter Day*; *Dramatis Personæ*, and some shorter poems. *The Ring and the Book* (1869), his longest poem, was followed by *Balaustion's Adventure*; and *Prince Hohenstiel-Schwangau* (1871); *Fifine at the Fair* (1872); *Red Cotton Nightcap Country* (1873); *Aristophanes' Apology*; *Inn Album* (1875); *Pacchiarotto* (1876); *La Saisiaz* (1878); *Dramatic Idylls* (1879-80); *Jocoseria* (1883); *Ferishtah's Fancies* (1884); and *Parleyings with certain People of Importance in their Day* (1887). Browning received the degree of D.C.L. from Oxford in 1882. A Browning Society for the study of his works was formed in 1881, under whose auspices several of his dramas have been performed. His poems are often difficult to understand from the quick transitions of thought, and they are not infrequently rugged and harsh in expression, yet they are among the chief poetic utterances of the century.

**Brownists**, the name given for some time to those who were afterwards known as *Independents*, so called from Robert Brown.

**Brownlow**, WILLIAM GANNAWAY, U. States senator, was born in Virginia in 1805; died in 1877. He was for ten years an itinerant Methodist preacher. As editor of the *Knoxville Whig* his bold and quaint utterances gave him a wide reputation. In the secession he clung to the Union, was arrested by the confederate government and sent out of their lines. In 1865 he was elected governor of Tennessee, and in 1869 U. States senator. He was an ardent, fearless advocate of any cause he espoused.

**Brownsville**, Cameron co., Texas, on the Rio Grande River, has extensive trade with Mexico. Pop. 1890, 6134.

**Brown University**, an American institution at Providence, Rhode Island, founded 1764. It has a valuable library of 60,000 vols.

**Bruce**, a family name distinguished in the history of Scotland. See the articles below.

**Bruce**, DAVID. See *David II.*

**Bruce**, EDWARD, a brother of Robert I., who, after distinguishing himself in the war of independence, crossed in 1315 to Ireland to aid the native sept against the English. After many successes he was crowned king of Ireland at Carrickfergus, but fell in battle near Dundalk in 1318.

**Bruce**, JAMES, African traveller, born at Kinnaird House, Stirlingshire, in 1730. He received his education at Harrow and at the University of Edinburgh, and entered the wine trade, but having inherited his father's estate in 1758 he soon gave up business. From 1763 to 1765 he held the consulship of Algiers, and in 1765 he visited successively Tunis, Tripoli, Rhodes, Cyprus, Syria, and several parts of Asia Minor, where he made drawings of the ruins of Palmyra, Baalbec, &c. In 1768 he set out for Cairo, navigated the Nile to Syene, crossed the desert to the Red Sea, passed some months in Arabia Felix, and reached Gondar, the capital of Abyssinia, in 1770. In that country he ingratiated himself with the sovereign and other influential persons, and in the same year succeeded in reaching the sources of the Abai, then considered the main stream of the Nile. On his return to Gondar he found the country engaged in a civil war, and more than three years elapsed before he was able to return to Cairo. After visiting France and Italy he returned to Scotland in 1774. His long-expected *Travels* did not appear until 1790, and were

received with some incredulity, though succeeding travellers have proved them in large part accurate. Bruce lost his life by an accidental fall down stairs in 1794.

**Bruce, MICHAEL**, a Scottish poet, born at Kinnesswood, Kinross-shire, in 1746. At first a herd-boy, he succeeded in attending Edinburgh University, occupying himself in the intervals as a village schoolmaster. The struggle against poverty brought on consumption, and he died in 1767. His poems, of which the best known is the *Elegy on his own approaching death*, were published by the Rev. John Logan in 1770. This volume contained a well-known ode to the cuckoo which Logan afterwards claimed as his own, though he really seems only to have somewhat improved Bruce's poem.

**Bruce, ROBERT (ROBERT DE BRUS)**, fifth lord of Annandale, born 1210, died at Lochmaben Castle 1295. He was possessed of extensive estates in Cumberland, of which he was made sheriff in 1255. He was one of the fifteen regents of Scotland during the minority of Alexander III.; and was one of the competitors for the Scottish crown on the death of Margaret, the Maiden of Norway, in 1290;—Bruce being the grandson of David, earl of Huntingdon, by his second daughter Isobel, while Baliol claimed as the great-grandson of the eldest daughter Margaret. On the decision of Edward being given in 1292 in favour of Baliol, Bruce resigned the estate of Annandale to his eldest son to avoid doing homage to his rival.

**Bruce, ROBERT**, Earl of Carrick, eldest son of the preceding, accompanied Edward I. to Palestine in 1269; married, in 1271, Martha Margaret, countess of Carrick. Like his father he resigned the lordship of Annandale to his eldest son to avoid acknowledging the supremacy of Baliol. On the revolt of the latter Bruce fought on the English side, and after the battle of Dunbar made an unsuccessful application to Edward for the crown. He died in 1304.

**Bruce, ROBERT**, the greatest of the kings of Scotland, born 1274. He was the son of the preceding. In 1296, as Earl of Carrick, he swore fealty to Edward I., and in 1297 fought on the English side against Wallace. He then joined the Scottish army, but in the same year returned to his allegiance to Edward until 1298, when he again joined the national party, and became in 1299 one of the four regents of the kingdom. In the three final campaigns, however, he resumed

fidelity to Edward, and resided for some time at his court; but, learning that the king meditated putting him to death on information given by the traitor Comyn, he fled in Feb. 1306, to Scotland, stabbed Comyn in a quarrel at Dumfries, assembled his vassals at Lochmaben Castle, and claimed the crown, which he received at Scone, March 27. Being twice defeated, he dismissed his troops, retired to Rathlin Island, and was supposed to be dead, when, in the spring of 1307, he landed on the Carrick coast, defeated the Earl of Pembroke at Loudon Hill, and in two years had wrested nearly the whole country from the English. He then in successive years advanced into England, laying waste the country; and on June 24, 1314, defeated at Bannockburn the English forces advancing under Edward II. to the relief of the garrison at Stirling. In 1316 he went to Ireland to the aid of his brother Edward, and on his return in 1318, in retaliation for inroads made during his absence, he took Berwick and harried Northumberland and Yorkshire. Hostilities continued until the defeat of Edward near Byland Abbey in 1323, and though in that year a truce was concluded for thirteen years, it was speedily broken. Not until March 4, 1328, was the treaty concluded by which the independence of Scotland was fully recognized. Bruce did not long survive the completion of his work, dying at Cardross Castle on June 7, 1329. He was twice married; first to a daughter of the Earl of Mar, Isabella, by whom he had a daughter, Marjory, mother of Robert II.; and then to a daughter of Aymer de Burgh, Earl of Ulster, Elizabeth, by whom he had a son, David, who succeeded him.

**Bruchsal** (brūh'zäl), a town of Baden, 25 miles s. of Heidelberg. It was the residence of the prince-bishops of Spire from the 11th century, but lost its importance until it became a considerable railway centre. The Grand-duke of Baden has a fine palace here. Pop. 11,373.

**Brucine**, an alkaloid accompanying strychnia in *nux vomica*. Its taste is exceedingly bitter and acrid, and its action on the animal economy is entirely analogous to that of strychnia, but much less powerful.

**Brueys-d'Aigalliers** (brü-ā-dā-gäl-yā), FRANÇOIS-PAUL, a French admiral, born at Uzés 1753, became captain in 1792, and vice-admiral in 1798. He successfully conveyed Bonaparte and his army to Egypt in 1798, but was killed in the subsequent naval

battle in the Bay of Aboukir shortly before his ship, the *Orient*, blew up.

**Bruges** (brüz; Flemish, *Brugge*, that is, Bridges), an old walled city of Belgium, capital of West Flanders, 57 miles N.W. Brussels, on the railway to Ostend. It is an important canal centre, and has over fifty bridges, all opening in the middle for the passage of vessels. The principal canals are those to Sluis, Ghent, and Ostend, on all of which pretty large vessels can come up to Bruges. In the 13th and 14th centuries it was one of the chief commercial places in Europe, and an important member of the Hanseatic League. Towards the end of the 15th century it began to decline, but still carries on a considerable trade with the north of Europe, and is by its canals an entrepôt of Belgian commerce. Among its more noteworthy buildings are the Halles (containing cloth and other halls or markets), a fine old building, with a tower 354 feet high, in which is a numerous set of chimes; the Hotel de Ville, the Bourse, and the Palace of Justice; the Church of Nôtre Dame, with its elevated spire and splendid tombs of Charles the Bold and Mary of Burgundy; &c. The town possesses interesting works of art by Jan Van Eyck, Memling, the Van Oosts, &c. Textile goods, lace, &c., are manufactured. Pop. 46,274.

**Brugsch** (brugsh), HEINRICH KARL, German Egyptologist, born in 1827. He early devoted himself to the study of Egyptian antiquities, and has resided a number of years in Egypt, being for some time in the employment of the Egyptian government, by which he was created a bey, and latterly a pasha. He has also travelled in various parts of the East. His works are very numerous. His History of Egypt from the Monuments has been translated into English.

**Brühl** (brül), HEINRICH COUNT VON, minister and favourite of Augustus III., king of Poland, born in 1700, died 1763. In 1747 he became the prime-minister of Augustus, to gratify whose wishes he exhausted the state, plunged the country into debt, and greatly reduced the army. He acquired great wealth and lived in greater state than the king himself. His profusion was often beneficial to the arts and sciences, and his library of 62,000 vols. forms a chief part of the Royal Library at Dresden.

**Brumaire** (brü-mär; L. *bruma*, winter), the second month in the calendar adopted by the first French republic, beginning on

the 23d of October and ending 21st November. The 18th Brumaire of the year VIII. of the French Revolution (Nov. 9, 1799) witnessed the overthrow of the Directory by Bonaparte. The next day he dispersed at the point of the bayonet the Council of Five Hundred, and was elected consul.

**Brummell**, GEORGE BRYAN (*Beau Brummell*), son of a clerk in the Treasury, born in London in 1778. He was educated at Eton and at Oxford, and at the age of sixteen made the acquaintance of the Prince of Wales, afterwards George IV., who made him a cornet in his own regiment of the 10th Hussars, and secured his rapid promotion. The death of his father in 1794 brought him a fortune of £30,000, which he expended in a course of sumptuous living, extending over twenty-one years, during which his *dicta* on matters of etiquette and dress were received in the *beau monde* as indisputable. His creditors at length became clamorous, and in 1816 he took refuge in Calais, where he resided for many years, partly supported by the remains of his own fortune and partly by remittances from friends in England. Subsequently (1830) he was appointed consul at Caen, but on the abolition of the post was reduced to absolute poverty, and died in a lunatic asylum at Caen in 1840.

**Brun** (brun), MALTE - CONRAD. See *Malte-Brun*.

**Brun'anburgh**, the scene of a battle in which Athelstan and the Anglo-Saxons defeated a force of Scots, Danes, &c., in 937: locality very doubtful.

**Brunck** (brunck), RICHARD FRANZ PHILIPP, classical commentator, born at Strasburg in 1729, died there in 1803. He published valuable editions of Virgil, Apollonius Rhodius, Aristophanes, the Gnostic poets, Plautus, Terence, and Sophocles—the last his masterpiece.

**Brundisium**. See *Brindisi*.

**Brune** (brün), GUILLAUME MARIE ANNE, Marshal of France, son of a lawyer at Brive-la-Gaillarde, born 1763. In 1793 he joined the army, and afterwards distinguished himself at Arcola and Verona as general of brigade in the Italian army. In 1799 he compelled the British and Russians to evacuate the north of Holland. In 1800 he pacified La Vendée, and, replacing Masséna as commander of the Italian army, led his troops over the Mincio, conquered the Austrians, passed the Adige, took possession of Vicenza and Roveredo, and hastened

the conclusion of peace. In 1802-4 he was ambassador at Constantinople, and the latter year was made a marshal. Losing the favour of Napoleon, he remained without employment for some years, but on the return of Napoleon from Elba he received an important command in the south of France, which he was soon after compelled to surrender at the second restoration. He then set out for Paris, but was attacked and brutally killed by the populace at Avignon.

**Brunehilda**, a Visigothic princess, married to Siegebert I., king of Austrasia, in 568. To avenge her sister (assassinated at the instigation of Fredegonde) she involved her husband in a war with his brother Chilperic, in the course of which Siegebert was murdered, A.D. 575, and she herself taken prisoner. She induced Meroveus, one of Chilperic's sons, to marry her, effected her escape, recovered her authority and maintained it till 613, when she was captured by Fredegonde's son, Clothaire II. of Soissons, who had her torn to pieces by wild horses as the murderess of ten kings and royal princes.

**Brunei** (brö'nī), **BRUNI**, an independent Malayan sultanate on the north-west coast of Borneo, between Sarawak and British North Borneo, exporting sago, gutta-percha, rubber, &c.; pop. 125,000. Its capital, also called Brunei, is situated on the river of same name, about 14 miles from its mouth, the houses being mostly raised above the water on posts. It has a considerable trade, its pop. being 30,000 to 35,000.

**Brunel'**, **ISAMBARD KINGDOM**, English engineer, son of Sir Mark Isambard Brunel, born in 1806, died in 1859. He was educated at the Henri IV. College, Paris; and commenced practical engineering under his father, acting at twenty as resident engineer at the Thames Tunnel. Among his best-known works were the *Great Western*, *Great Britain*, and *Great Eastern* steamships; the entire works on the Great Western Railway, to which he was appointed engineer in 1833, the Hungerford Suspension-bridge, docks at Plymouth, Milford Haven, &c.

**Brunel'**, **SIR MARK ISAMBARD**, a distinguished engineer, was the son of a Normandy farmer, and born near Rouen in 1769. He was educated in Rouen, his mechanical genius early displaying itself. In 1786 he entered the French naval service, and in 1793 only escaped proscription by a hasty flight to America, where he joined a French expedition to explore the regions around

Lake Ontario. He was afterwards employed as engineer and architect in the city of New York, erecting forts for its defence, and establishing an arsenal and foundry. In 1799 he proceeded to England and settled at Plymouth, rapidly winning reputation by the invention of an important machine for making the block-pulleys for the rigging of ships. Among his other inventions were a machine for making seamless shoes, machines for making nails and wooden boxes, for ruling paper and twisting cotton into hanks, and a machine for producing locomotion by means of carbonic acid gas; but his greatest engineering triumph was the Thames Tunnel, commenced March, 1825, and opened in 1843. In 1841 the honour of knighthood was conferred on him. He died in Dec. 1849.

**Brunelleschi** (brö-nel-es'kē), **FILIPPO**, Italian architect, born 1377 at Florence. He won some reputation as an inventor and sculptor, and made special studies in the then little known science of perspective, but devoted himself particularly to architecture. When at Rome with Donatello he conceived the idea of bringing architecture back to Græco-Roman principles as opposed to the dominant Gothic. In this he was successful, his work opening the way for Alberti, Bramante, Vignola, and Palladio. His great achievement was the dome of the cathedral of Santa Maria at Florence, the possibility of which was denied by other architects. It has remained unsurpassed, the dome of St. Peter's, though it excels it in height, being inferior to it in massiveness of effect. Other important works by him were the Pitti Palace at Florence, the churches of San Lorenzo and Spirito Santo, and the Capella dei Pazzi. Died in 1446.

**Brunet** (brü-nā), **JACQUES CHARLES**, French bibliographer and bookseller at Paris, born 1780, died 1867. He began his bibliographical career by the preparation of several auction catalogues, and of a supplementary volume to the *Dictionnaire Bibliographique* of Cailleau and Duclos (Paris, 1802). In 1810 was published the first edition of his valuable *Manuel du Libraire*, which has gone through many editions and extensions, and is still perhaps the best book of its class.

**Bruni**, an oddly-shaped island on the south coast of Tasmania, consisting of N. Bruni and S. Bruni, united by a narrow slip of land.

**Bruni**. See *Brunei*.



**Bruni**, LEONARDO. See *Bruno*.

**Brunings** (brö'ningz), CHRISTIAN, a great hydraulic architect of Holland, born in 1736; appointed general inspector of rivers by the States of Holland in 1769; died 1805.

**Brünn** (brün), an Austrian city, capital of Moravia, on the railway from Vienna to Prague, nearly encircled by the rivers Schwarzawa and Zwitzawa. It contains a cathedral and other handsome churches; a landhaus, where the provincial assembly meets, and several palaces; and has extensive manufactures of woollens, which have procured for it the name of the Austrian Leeds. It is the centre of Moravian commerce, a great part of which is carried on by fairs. Near it is the fortress of Spielberg, in which Trenck and Silvio Pellico were confined. Pop. 1891, 95,342.

**Bruno**, GIORDANO (jor-dä'nō), an Italian philosopher of the Renaissance, born at Nola about 1550. He entered the order of Dominicans, but was accused of impiety, and, after enduring much persecution, fled from Rome about 1577 to Geneva. Here he was soon persecuted in turn by the Calvinists, and travelled slowly through southern France to Paris, where he was offered a chair of philosophy, but declined to fulfil its conditions of attendance at mass. He lectured for some time, however, but in opposition to the antiquated Aristotelianism of the time and in exposition of a logical system based on the *Ars Magna* of Raymond Lully. In 1583 he went to London, where he published several of his works, and to Oxford, where he taught for a short time. In 1585 he went by way of Paris and Marburg to Wittenberg, and from 1586 to 1588 taught his philosophy there. He next went to Prague and to Helmstedt, where he remained till 1589; thence to Frankfort until 1592; and finally to Padua, where he remained until the inquisition of Venice arrested him and transferred him to Rome. After an imprisonment of seven years, during which he steadfastly refused to retract his doctrines, he was burned, February 16th, 1600, for apostasy, heresy, and violation of his monastic vows. Most of his works were published between 1584 and 1591, the chief being the *Cena de la Ceneri* (Ash-Wednesday Table-talk, dialogues giving an exposition of the Copernican theory); the *Spaccio della Bestia Trionfante* (Expulsion of the Triumphant Beast, a moral allegory); the *Della Causa, Principio ed Uno*; and the *Dell' Infinito, Universo, e Mondi*—all in

1584; the *Cabala del Cavallo Pegaseo* in 1585; and the three metaphysical works, *De triplici Minimo et Mensura*; *De Monade, Numero et Figura*; and *De Immenso et Innumerabilibus*—all in 1591. His doctrines form a more complete Pantheistical system than had been previously exhibited, and represent the highest level of the thought of the period.

**Bruno**, or BRUNI (BRUNUS), LEONARDO, an Italian scholar, born in 1370 at Arezzo, whence his name *Areтино*. He was secretary to the papal chancery under Innocent VII., Gregory XII., Alexander V., and John XXIII. On the deposition of the latter he escaped to Florence, where he wrote his history of Florence, received in consequence the rights of citizenship, and afterwards, by the favour of the Medici, became secretary to the republic till his death in 1444. He did much to advance the study of Greek literature by his literal Latin translations from Aristotle, Demosthenes, Plutarch, &c., and was the author of biographies of Dante and Petrarca.

**Bruno**, St.—1. The Benedictine apostle of Prussia who accompanied St. Adalbert to Prussia, was appointed chaplain to the Emperor Henry II., and who, having been taken by the Pagans of Lithuania, had his hands and feet cut off, and was beheaded in 1008. 2. The founder of the order of Carthusian monks, born at Cologne about 1030 of an old and noble family; appointed by the bishop Gervais superintendent of all the schools of the Rheims district, whither he attracted many distinguished scholars, among others Odo, afterwards Pope Urban II. Subsequently he was offered the bishopric of Rheims, but, declining it, repaired with six friends to Hugo, bishop of Grenoble, who, in 1084 or 1086, led them to the Chartreuse, the spot from which the order of monks received its name. Here, in a bleak and narrow valley, Bruno and his companions built an oratory, and small separate cells for residence. In 1089 he reluctantly accepted the invitation of Urban II. to Rome, but refused every spiritual dignity, and in 1094 founded a second Carthusian establishment in Della Torre, Calabria. Here he died in 1101. He was beatified by Leo X. and canonized by Gregory XV.

**Bruno**, The Great, Archbishop of Cologne and Duke of Lorraine, third son of Henry the Fowler, and brother of the Emperor Otho I. He was employed in various important negotiations, and was a great

patron of learning. Commentaries on the Pentateuch, and some biographies of saints, are ascribed to him. He died, 965, at Rheims.

**Brunonian Theory** (in medicine). See *Brown, John, M.D.*

**Brunswick** (German, *Braunschweig*), a duchy and sovereign state in the north-west of Germany, area 1425 sq. m. It is divided into several detached portions, surrounded by the Prussian provinces of Hanover, Saxony, and Westphalia. A good portion of it is hilly or undulating, and it partly belongs to the Harz mountain system. Mining is carried on chiefly in the Harz, and the minerals include iron, lead, copper, brown coal, &c. About half the surface is arable, and the chief cultivated products are grain, flax, hops, tobacco, potatoes, and fruit. Brewing, distilling, the manufacture of linens, woollens, and leather, the preparation of paper, soap, tobacco, beet-sugar, with agriculture and mining, afford the principal employment of the people. As a state of the German Empire it sends two members to the Bundesrath, and three deputies to the Reichstag. In its internal government it is a constitutional monarchy. On the death of the Duke of Brunswick without issue in 1884 the Duke of Cumberland claimed the succession. Bismarck, however, interfered, and the Brunswick diet decided to place the duchy under a regent—Prince Albrecht of Prussia being elected to the post. The estimated revenue and expenditure for 1892–93 were each 13,010,000 marks; the debt being 27,885,588 marks. Pop. 403,773, mostly Lutherans by religion. (See *Brunswick, Family of*.)—**BRUNSWICK**, the capital, is situated on the Oker, and on the railway from Hanover to Berlin. The older streets are narrow, tortuous, and antiquated. The principal buildings of note are the ducal palace, the cathedral of St. Blaise (1173), St. Catherine's Church (dating from 1172), and St. Magnus's (1031), the Gewandhaus, and the fine old Gothic Council House. The educational institutions include the polytechnic school, a gymnasium, &c., and there are a city museum, a ducal museum, and a public library. The principal manufactures are wool, linen, jute, machinery, sewing-machines, &c. Pop. 1890, 100,288.

**Brunswick**, the seat of Glynn county, Ga., centre of lumber district. Pop. 8459.

**Brunswick**, a town of Maine, United States, on the Androscoggin, 26 miles N.E. of Portland. At Bowdoin College, in this

town, Hawthorne and Longfellow graduated in 1825, and the latter filled the chair of modern languages for several years. Pop. 6012.

**Brunswick, FAMILY OF**, a distinguished family founded by Albert Azo II., Marquis of Reggio and Modena, a descendant, by the female line, of Charlemagne. In 1047 he married Cunigunda, heiress of the Counts of Altorf, thus uniting the two houses of Este and Guelph. From his son, Guelph, who was created Duke of Bavaria in 1071, and married Judith of Flanders, a descendant of Alfred of England, descended Henry the Proud, who succeeded in 1125, and by marriage acquired Brunswick and Saxony. Otho, the great-grandson of Henry by a younger branch of his family, was the first who bore the title of Duke of Brunswick (1235). By the two sons of Ernest of Zell, who became duke in 1532, the family was divided into the two branches of Brunswick-Wolfenbüttel (II.) and Brunswick-Hanover, from the latter of which comes the present royal family of Britain. The former was the German family in possession of the duchy of Brunswick until the death of the last duke in 1884. George Louis, son of Ernest Augustus and Sophia, granddaughter of James I. of England, succeeded his father as Elector of Hanover in 1698, and was called to the throne of Great Britain in 1714 as George I.

**Brunswick, FERDINAND, DUKE OF**, fourth son of Duke Ferdinand Albert, was born at Brunswick 1721. In 1739 he entered the Prussian service, was engaged in the Silesian wars, and in the Seven Years' War commanded the allied army in Westphalia. He drove the French from Lower Saxony, Hesse, and Westphalia, and was victorious at Crefeld and Minden. After the peace he retired to Brunswick, and died in 1792.

**Brunswick, FRIEDRICH WILHELM, DUKE OF**, fourth and youngest son of Duke Karl Wilhelm Ferdinand of Brunswick; born in 1771. During the war against France, in 1792 and subsequently, he fought in the Prussian armies, was twice wounded, and once made prisoner with Blücher at Lubeck. For the campaign of 1809 he raised a free corps in Bohemia, but was compelled to embark his troops for England, where he was received with enthusiasm. His corps immediately entered the British service, and was afterwards employed in Portugal and Spain, the parliament granting him a pension of £6000, until he returned to his hereditary domin-

ions, 1813. The events of 1815 called him again to arms, and he fell at Quatre Bras, 1815. Caroline, wife of George IV., was a sister of this prince.

**Brunswick**, KARL WILHELM FERDINAND, DUKE OF, born in 1735; entered upon the government in 1780. He received the chief command of the Austrian and Prussian army against France in 1792, and designed to press forward from Lorraine to Paris, but, after taking Longwy and Verdun, was baffled in Champagne by Dumouriez, defeated at Valmy by Kellerman, and obliged to evacuate the province. In 1793 the duke, in conjunction with the Austrians, opened the campaign on the upper Rhine, took Königstein and Mentz, and prepared to attack Landau. After a long struggle with varying success the Austrian lines were broken by Pichegru, and the duke was obliged to follow their retreat across the Rhine. At Auerstadt he was mortally wounded in 1806.

**Brunswick, NEW.** See *New Brunswick*.

**Brunswick Black**, a varnish composed chiefly of lamp-black and turpentine, and applied to cast-iron goods. Asphalt and oil of turpentine are also ingredients in some kinds of it.

**Brunswick Green**, commonly a carbonate of copper mixed with chalk or lime.

**Brusa**, BROUSSA (brö'sà), or BURSA, a Turkish city in Asia Minor, south of the Sea of Marmora, about 20 miles distant from its port Mudania, with a pop. of about 70,000 Turks, Greeks, Armenians, and Jews, engaged in commerce, and the manufacture of satins, silk stuffs, carpets, gauze, &c. The town is situated in a fertile plain, which is inclosed by the ridges of Olympus, and abounds in hot springs. Brusa represents the ancient Prusa, long capital of Bithynia, and one of the most flourishing towns in the Greek empire of Constantinople. It was the residence of the Turkish sovereigns from 1329 until the transference of the seat of empire to Adrianople in 1365.

**Brush**, a well-known implement used for various purposes. There are two chief varieties, those with stiff hair or fibres, and those with flexible. The former are made of hogs' bristles, whalebone fibres, vegetable fibres of various kinds (brush-grass, palms, &c.), and sometimes wire is made to serve the same purpose. The latter are made of hogs' bristles, or of the hair of the camel, badger, squirrel, sable, goat, &c., and are chiefly used for painting, the smallest kinds being called *pencils*.

**Brush-grass** (*Andropogon gryllus*), a grass of S. Europe, with stiff wiry roots which are used for making brushes.

**Brush-turkey.** See *Tallegalla*.

**Brush-wheel**, a toothless wheel sometimes used in light machinery to turn a similar wheel by means of bristles or some brush-like or soft substance, as cloth, buff-leather, india-rubber, or the like.

**Brussa.** See *Brusa*.

**Brus'sels** (Flemish, *Brussel*; French, *Bruelles*), the capital of Belgium and of the province of Brabant, is situated on the small river Senne, which is not navigable, but serves as a canal-feeder. The city consists of a north-western or lower portion and a south-eastern or upper portion. The older part is surrounded with fine boulevards on the site of its fortifications, and in many places presents a congeries of twisted streets. The upper town, which is partly inside the boulevards and partly outside, is the finest part of the city, and contains the king's palace, the palace of the chambers, the palace of justice (a magnificent new building of colossal proportions in the classical style, ranking among the finest in Europe), the palace of the fine arts, the public library and museum, &c.; and has also a fine park of 17 acres, around which most of the principal buildings are situated. The lower town retains much of its ancient appearance. The hôtel de ville (1401-55) is an imposing Gothic structure, with a spire 364 ft. in height, the square in front of it being perhaps the most pictorial of all the public places of Brussels. The cathedral of Saint Gudule (dating in part from the 13th century) is the finest of many fine churches, richly adorned with sculptures and paintings. The whole town is rich in monuments and works of art. The institutions comprise a university, an academy of science and the fine arts and polytechnic school; one of the finest observatories in Europe; a conservatorium of music; a public library, containing 400,000 volumes and 30,000 MSS.; a picture-gallery, with the finest specimens of Flemish art; and many learned societies and educational organizations. The manufactures and trade are greatly promoted by canal communications with Charleroi, Mechlin, Antwerp, and the ocean, and by the net-work of Belgian railways. The industries are varied and important. Lace was an ancient manufacture, and is still of great importance; the manufacture of cotton and woollen fabrics, paper, carriages, and many minor manufac-

tures are carried on. There are breweries, distilleries, sugar-refineries, foundries, &c. The language spoken by the upper classes is French, and Flemish is that of the lower; but German, Dutch, and English are also a good deal spoken.—During the middle ages Brussels did not attain great importance. It was walled by Baldric of Louvain in 1044; was more completely fortified in 1380; and was twice burned and once ravaged by the plague during the 15th century. It was bombarded and burned by the French in 1695; and was again taken by the French in 1794, and retained till 1814, when it became the chief town of the department of the Dyle. From 1815 to 1830 it was one of the capitals of the Kingdom of the Netherlands, and in 1830 was the chief centre of the revolt which separated Belgium from Holland. Pop. 1891, 482,268.

**Brussels Carpet.** See *Carpet*.

**Brussels Sprouts**, one of the cultivated varieties of cabbage (*Brassica oleracea*), having an elongated stem 4 or 5 feet high, with small clustering green heads like miniature cabbages. They are cultivated in great quantities near Brussels.

**Brutus**, or BRUTE, the first king of Britain; a purely mythical personage, said to have been the son of Sylvius, and grandson of Ascanius, the son of Æneas. He landed in Devonshire, destroyed the giants then inhabiting Albion, and called the island from his own name. At his death the island was divided among his sons: Locrine, Cumber, and Albanact.

**Brutus**, DECIMUS JUNIUS, served under Julius Cæsar in Gaul, and was afterwards commander of his fleet, but, like his relative, Marcus Junius Brutus, joined in the assassination of Cæsar. He was afterwards for a short time successful in opposing Antony, but was deserted by his soldiers in Gaul and betrayed into the hands of his opponent, who put him to death in B.C. 43.

**Brutus**, LUCIUS JUNIUS, ancient Roman hero, son of Marcus Junius by the daughter of the elder Tarquin. He saved his life from the persecutions of Tarquin the Proud by feigning himself insane, whence his name *Brutus* (stupid). On the suicide of Lucretia (see *Lucretia*), however, he threw off the mask, and headed the revolt against the Tarquins. Having secured their banishment, he proposed to abolish the regal dignity and introduce a free government, with the result that he was elected to the con-

sulship, in which capacity he condemned his own sons to death for conspiring to restore the monarchy. He fell in battle B.C. 509.

**Brutus**, MARCUS JUNIUS, a distinguished Roman, born B.C. 85; was at first an enemy of Pompey, but joined him on the outbreak of civil war until the battle of Pharsalia. He then surrendered to Cæsar, who made him in the following year governor of Cisalpine Gaul, and afterwards of Macedonia. He soon, however, joined the conspiracy

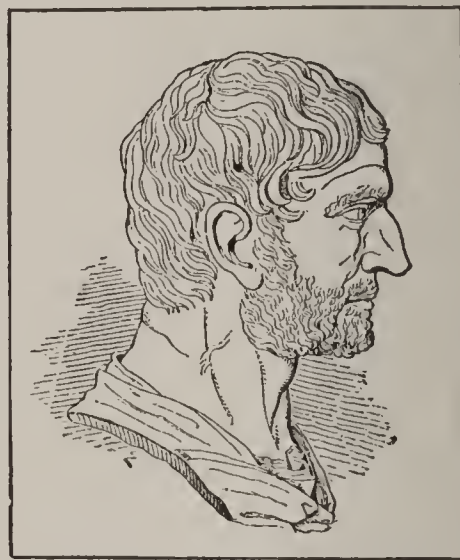

Marcus Junius Brutus.—Antique Bust.

against Cæsar, and by his influence ensured its success. After the assassination he took refuge in the East, made himself master of Greece and Macedonia, and with a powerful army joined Cassius in the subjugation of the Lycians and Rhodians. In the meantime the triumvirs, Octavianus, Antony, and Lepidus, had been successful at Rome, and were prepared to encounter the army of the conspirators, which, crossing the Hellespont, assembled at Philippi in Macedonia. Cassius appears to have been beaten at once by Antony; and Brutus, though temporarily successful against Octavianus, was totally defeated twenty days later. He escaped with a few friends; but, seeing that his cause was hopelessly ruined, fell upon the sword held for him by his confidant Strato, and died (B.C. 42).

**Brüx** (brüks), a town of Bohemia, on the Biela, in the neighbourhood of which are extensive coal-fields, and the famous mineral springs of Seidlitz and Püllna. Pop. 9995.

**Bruyère** (brü-yār), JEAN DE LA, a French writer, born at Paris in 1645. He purchased the place of treasurer at Caen; but a short



The New Law Courts or Palais de Justice, Brussels.

time after, through the influence of Bossuet, he was employed in the education of the Duke of Bourbon, grandson of the great Condé, with a pension of 3000 livres, and was attached to his person during the remainder of his life. In 1688 he published a translation of the Characters of Theophrastus into French, and accompanied them with a succession of characters, in which he represented the manners, and frequently the leading personages, of his time in an ingenious and piquant style. In 1695 he was elected a member of the French Academy. He died in 1696.

**Bry'ant**, JACOB, English philologist and antiquary, born in 1715, died in 1804. He studied at Eton and Cambridge; became tutor of the sons of the famous Duke of Marlborough, the eldest of whom he accompanied to the Continent as secretary, and after his return received a lucrative post in the ordnance, which gave him leisure for researches into Biblical, Roman, and Grecian antiquities. His most important work was the *New System of Ancient Mythology*, 1774-76. Amongst other things he endeavoured to prove the purely fictional nature of the Iliad, and that Melita, on which St. Paul was wrecked, was not Malta, but an island in the Adriatic.

**Bry'ant**, WILLIAM CULLEN, an American poet and journalist, born in Cummington, Mass., in 1794. At ten years of age he published translations from Latin poets; at thirteen wrote *The Embargo*; and at eighteen the *Thanatopsis*. In 1815 he was admitted to the bar, and practised with success till 1825, when he established the *New York Review*. In 1826 he became assistant editor of the *Evening Post*, a leading organ of the *New York Democrats*, of which he was long chief editor. His poems, first collected in 1832, took rank as the best America had up to that time produced. In 1842 he issued *The Fountain* and other poems; and a new edition of his poems in 1858 was followed by metrical translations of the Iliad in 1869 and of the Odyssey in 1871. His *Letters of a Traveller* record his visits to Europe in 1834 and subsequently. He died in 1878.

**Bry'ony** (*Bryonia*), a genus of plants, nat. order Cucurbitaceæ (gourds). The only British species, the Common Bryony (*B. dioica*), a climbing plant common in hedges, has cordate palmate leaves and axillary bunches of flowers, and red berries which are highly poisonous. The thick long fleshy

root has acrid emetic and purgative properties, and has been used medicinally. Other species, one found in N. America, are known. The so-called Black Bryony (*Tamus communis*) belongs to a different natural order, the Dioscoreaceæ or yams. It has cordate undivided leaves, greenish flowers, red berries, and a black fleshy root.

**Bryozo'a** (Gr. *bryon*, moss, and *zōon*, an animal), a name formerly given to the Polyzoa, from their moss-like appearance.

**Brzesc-Litowski**. See *Brest-Litowski*.

**Buansu'ah** (*Cyon primævus*), a wild dog of Northern India, supposed by some to be the original type of the dog tribe.

**Bu'baline Antelope** (*Bubālis mauretunica*), an ox-like antelope of N. Africa, of a yellowish-brown colour, with horns at first pointing forward and outward, and then turning backward. It inhabits the desert tracts.

**Bu'balus**, the genus to which the buffalo belongs.

**Bubas'tis**, an ancient Egyptian town, so named from the goddess Bast, supposed to answer to the Greek Artēmis or Diana. The cat was sacred to her, and the Bubasteia or festivals of the goddess were the largest and most important of the Egyptian festivals.

**Bubo**, an inflammatory swelling of a lymphatic gland, usually occurring in the groin, but also elsewhere.

**Bubo**, a genus of owls, including the great horned or eagle owl (*B. maximus*), and the Virginian horned owl (*B. virginianus*).

**Buccaneers'**, a name derived from Carib *boucan*, a place for smoking meat, first given to European settlers in Hayti or Hispaniola, whose business was to hunt wild cattle and swine and smoke their flesh. In an extended sense it was applied to English and French adventurers, mostly seafaring people, who, combining for mutual defence against the arrogant pretensions of the Spaniards to the dominion of the whole of America, frequented the W. Indies in the 17th century, acquired predatory and lawless habits, and became ultimately, in many cases, little better than pirates. The earliest association of these adventurers began about 1625, but they afterwards became much more formidable, and continued to be a terror until the opening of the 18th century, inflicting heavy losses upon the shipping trade of Spain, and even attacking large towns. Among their chief leaders were Montbars (Il exterminador), Peter the Great of Dieppe, L'Olonnas, de Busco, Van Horn,

and the Welshman Henry Morgan, who, in 1670, marched across the isthmus, plundered Panama, and after being knighted by Charles II., became deputy-governor of Jamaica. The last great exploit of the buccaneers was the capture of Carthagena in 1697, after which they are lost sight of in the annals of vulgar piracy.

**Buccinator** (buk-si-nā'ter; L., a trumpeter, from *buccina*, a trumpet), the trumpeter's muscle, a flat thin muscle forming the wall of the cheek, assisting in mastication and regulating the expulsion of the air in whistling or playing a wind-instrument.

**Bucleugh** (bu-klö), the title (now a dukedom) of one of the oldest families in Scotland, tracing descent from Sir Richard le Scott in the reign of Alexander III. (latter half of the 13th century), and first becoming conspicuous in the person of the border chieftain Sir Walter Scott of Branxholm and Bucleugh—the latter an estate in Selkirkshire. The son of Sir Walter, bearing the same name, was for his valour and services raised to the peerage in 1606 as Lord Scott of Bucleugh, and his successor was made an earl in 1619. In 1663 the titles and estates devolved upon Anne, daughter of the second earl, who married the Duke of Monmouth, illegitimate son of Charles II., the pair in 1673 being created Duke and Duchess of Bucleugh, &c. Subsequently the Dukedom of Queensberry passed by marriage into the family.

**Buccon'idæ.** See *Barbets*.

**Bucen'taur**, a mythical monster, half man and half ox. The splendid galley in which the doge of Venice annually wedded the Adriatic bore this name.

**Buceph'alus** ('Ox-head'), the horse of Alexander the Great. On its death from a wound Alexander built over its grave, near the Hydaspes, a city called *Bucephala*.

**Bucer** (bu'tser), MARTIN, a 16th-century reformer, whose real name was Kuhhorn (cow-horn), of which *Bucer* is meant to be the Greek equivalent, born 1491 at Schlettstadt, in Alsace. In 1521 he left the Dominican order and became preacher at the court of the Elector Frederick, and afterwards in Strasburg, where he was professor in the university for twenty years. In 1548 Edward VI. invited him to Cambridge, where he held the office of professor of theology, and died in 1551. In 1557 Queen Mary caused his bones to be burned. Cardinal Contarini called him the most learned divine among the heretics. He wrote a

commentary on the Psalms under the name of Aretius Filinus, and many other works.

**Bu'ceros.** See *Horn-bill*.

**Buch** (buh), LEOPOLD VON, a German geologist, born in 1774, died in 1853. He made extensive geological excursions on the Continent of Europe, and also visited the Canary Islands, the Hebrides, and the coasts of Scotland and Ireland. He was the author of various important works; and compiled a magnificent Geological Map of Germany.

**Buchan** (buh'an), a district of Scotland, lying in the N.E. of Aberdeenshire, between the mouths of the Deveron and the Ythan.

**Buchan** (buk'an or buh'an), WILLIAM, a Scotch medical writer, born in 1729; studied at Edinburgh, and commenced practice there, where also he published in 1769 his work entitled *Domestic Medicine; or, the Family Physician*—the first work of the kind published in Britain. Before his death, in 1805, nineteen large editions had been sold. It was translated into French, and became even more popular on the Continent and in America than at home. Buchan was induced by its success to remove to London, where for many years he enjoyed a lucrative practice.

**Buchanan** (bu-kan'an), CLAUDIUS, D.D., a distinguished missionary in India, born at Cambuslang, Scotland, in 1766. He was educated at the Universities of Glasgow and Cambridge; became chaplain to the East India Company in 1795; and in 1800 was appointed professor of Greek, Latin, and English, and vice-provost in the college at Fort-William. He returned to Europe in 1808, and in 1811 published his *Christian Researches in Asia*, with a *Notice of the Translation of the Scriptures into the Oriental Languages*. He died in 1815.

**Buchanan**, GEORGE, Scottish reformer, historian, scholar, and Latin poet, born in the parish of Killearn, Stirlingshire, in 1506. An uncle sent him in 1520 to the University of Paris, but the death of his uncle compelled his return, and in 1523 he joined the French auxiliaries employed by the regent, Albany, serving as a private soldier in one campaign against the English. He was then sent to the University of St. Andrews, where he took the Arts degree in October, 1525. Following his tutor, Mair or Major, to France, he became in 1526 a student in the Scots College of Paris; took his degrees; in 1529 was elected professor in the College of St. Barbe; and in 1532 was engaged as friend and tutor of Gilbert Ken-

ned, earl of Cassillis, with whom he resided for five years, and to whom he inscribed his first published work, a translation of Lincacre's Rudiments of Latin Grammar, printed in 1533. In 1536 Cassillis and Buchanan returned to Scotland, where the latter published his *Somnium*, a satire against the Franciscans. To shield him from the hostility of the R. Catholic party, James V. retained him as preceptor to his natural son James Stuart, encouraging him to write the *Franciscanus*, one of the most pungent satires to be found in any language. By the Catholic influence he was arrested in 1539, but escaped to London and thence to France, where he became professor of Latin at Bordeaux, wrote his tragedies *Jephthes* and *Baptistes*, and translated the *Medea* and *Alcestis* of Euripides. Among his pupils was Montaigne, and he was on intimate terms with the elder Scaliger. From Bordeaux Buchanan removed to Paris, and thence to Portugal to take a chair in the University of Coimbra. Here he was sentenced by the Inquisition to be confined in a monastery, but at length received permission to depart, and was shortly afterwards appointed to a regency in the College of Boncourt at Paris, an office held by him till 1555, when he was engaged as tutor to the son of the Comte de Brissac. During this period a portion of his version of the Psalms in Latin verse was published. About 1560 he returned to Scotland, and for some time acted as tutor to the young queen Mary, to whom he dedicated his version of the Psalms. He had now openly joined the leaders of the Reformation. In 1566 he was nominated principal of St. Leonard's College, St. Andrews, and in the following year was chosen moderator of the General Assembly, the only instance of the chair being held by a layman. When Elizabeth called witnesses from Scotland to substantiate the charges against Mary, Buchanan accompanied the Regent Moray into England, and his evidence against her was highly important. In 1570 he was selected to superintend the education of King James, whom he made an excellent scholar. He was also appointed keeper of the privy-seal, a post which he held till 1578. In 1579 he published his *De Jure Regni apud Scotos*, a work in which he defended the rights of the people to judge of and control the conduct of their governors, and which subsequently had much influence on political thought. The dedication of his *Rerum Scoticarum Historia* (His-

tory of Scotland) to the king is dated August 29th, 1582, and on the 28th September following Buchanan died. As a Latinist both in prose and verse he was perhaps the best of his day, as evidenced by his *History* and his version of the Psalms. As regards its matter, the former is entirely uncritical, and is of value only for matters belonging to his own time.

**Buchanan, JAMES**, fifteenth president of the United States, born in Pennsylvania 1791; son of an Irishman who had quitted Europe in 1783. James Buchanan was educated at Dickinson College, Carlisle; was admitted to the bar in 1812; was elected to the legislature of Pennsylvania in 1814; in 1820 was elected to Congress, of which he continued a member till 1831. After having been sent to Russia to conclude a commercial treaty he was in 1834 elected to the Senate, and under the presidency of Polk (1845-49) was appointed secretary of state. During the presidency of General Taylor he retired from public life, but in 1853 General Pierce, who was then president, named him ambassador of the United States at London. He returned to America in 1856 as Democratic candidate for the presidency, and was elected by a large majority over Fremont, the Republican candidate, and inaugurated in March, 1857. By his proslavery views Buchanan succeeded in delaying the storm which burst out on the election of his successor Lincoln. He lived in retirement after the close of his administration (1861), of which he published an account two years before his death in 1868.

**Buchanan, ROBERT**, an English poet, born in 1841. His earliest volumes of verse—*Undertones* (1863), *Idylls and Legends of Inverburn* (1865), and *London Poems* (1866), gained him a good reputation for truth, simplicity, humour, and pathos, and he has since produced various volumes of poetry which have been no less well received; such as *Wayside Poesies* (1866), *North Coast and other Poems* (1867); *The Drama of Kings* (1871); *Ballads of Life, Love, and Humour* (1882); *The City of Dream* (1888). He has also written novels—*The Shadow of the Sword*, *God and the Man*, *the Child of Nature*, *Foxglove Manor*, &c., and a number of plays.

**Buchanites**, an extraordinary sect of Scottish fanatics which sprang up in 1783 in a dissenting church at Irvine, Ayrshire, under the leadership of a Mrs. (more commonly known as Lucky) Buchan. She declared



herself to be the woman of Rev. xii., and Mr. White, the clergyman of the congregation to which she belonged, her 'man-child,' and taught her followers they would be translated to heaven without tasting of death. The sect was always small, and became extinct soon after the death of Mrs. Buchan in 1792. They are said to have lived in promiscuous intercourse, and to have despised marriage.

**Buchan Ness**, the easternmost promontory of Scotland, near Peterhead, Aberdeenshire.

**Bucharest.** See *Bukarest*.

**Bucharia.** See *Bokhara*.

**Buchez** (bû-shā), PHILIPPE JOSEPH BENJAMIN, French physician and writer, born in 1796. He wrote *Introduction à la Science de l'Histoire* (1833) and *Essai d'un Traité Complet de Philosophie* (1839). Between 1833 and 1838 he published, in concert with M. Roux-Lavergne, a *Histoire Parlementaire de la Révolution Française* (40 vols.) After the revolution of 1848 he was elected to the constituent National Assembly, and was for a brief period its wholly incompetent president. Retiring from public life he confined himself to literature, his chief subsequent work being the *Histoire de la Formation de la Nationalité Française* (1859). He died in 1865.

**Buchholz** (buh'hōlts), a town of Saxony, with extensive manufactures of laces, trimmings, &c. Pop. 6539.

**Buchon** (bû-shōn), JEAN ALEXANDRE, a French historical writer, born 1791, died in 1846. After a period of European travel for the collection of documents he published his *Collection des Chroniques Nationales Françaises, écrites en Langue Vulgaire du XIII<sup>e</sup> au XVI<sup>e</sup> Siècle* (47 vols., 1824-29), commencing with the *Chroniques de Froissart*. For a short time (1828-29) he was inspector of the archives and libraries of France. Among other works may be noted his *Histoire Populaire des Français* (1832); *La Grèce Continentale et la Morée* (1843).

**Buchu** (buk'ū). See *Bucku*.

**Buck**, the male of the fallow-deer, of the goat, rabbit, and hare.

**Buckau** (buk'ou), a town of Prussian Saxony, close to Magdeburg, of which it may be considered a suburb; with flourishing manufactures, especially of machinery and iron goods. Pop. 12,605.

**Buck-bean**, BOG-BEAN, or MARSH-TREFOIL (*Menyanthes trifoliāta*), a beautiful plant of the order Gentianaceæ, common in spongy,

boggy soils, and found in Britain, throughout Europe, in Siberia, and in North America. It is from 6 to 12 inches in height, and flowers in Britain about the latter end of June, the flower-stalk terminating in a thyrse of white flowers, while the inner surface of the corolla has a coating of dense fleshy hairs. The whole plant, the root especially, has an intensely bitter taste, and formerly ranked highly as a tonic.

**Bückeberg** (bük'e-bürh), a town of Germany, capital of the principality of Schaumburg-Lippe. Pop. 5000.

**Buckeye**, an American name for certain species of horse-chestnuts.

**Buck-hound**, a kind of hound similar to but smaller than a stag-hound, once commonly used in Britain for hunting bucks. The Master of the Buck-hounds is still the title of an officer of the royal household in England.

**Buckie**, an important fishing-town on the coast of Banffshire, Scotland. Pop. 4176.

**Buck'ingham**, or BUCKS, an inland county, England, bounded by Northampton, Bedford, Hertford, Middlesex, Berks, and Oxford; area about 730 sq. miles, or 467,009 acres, of which over 400,000 are under crops or permanent pasture. The rich vale of Aylesbury stretches through the centre, and a portion of the Chiltern range across the south of the county, which is watered by the Ouse, the Thame, and the Thames. The breeding and fattening of cattle and pigs are largely carried on, also the breeding of horses, and much butter is made. The manufactures are unimportant, among them being straw-plaiting, thread lace, and the making of wooden articles, such as beechen chairs, turnery, &c. There are also paper-mills, silk-mills, &c. The mineral productions are of no great importance. The county comprises eight hundreds, those of Stoke, Burnham, and Desborough being known as 'the Chiltern Hundreds.' Buckingham is nominally the county town, but Aylesbury is the assize town. The county returns three members to the House of Commons for the Aylesbury, Buckingham, and Wycombe districts. Pop. 185,190.—BUCKINGHAM, the co. town, a municipal, and, until 1885, a parl. borough, is pleasantly situated on a peninsula formed by the Ouse. Malting and tanning are carried on, and some lace is made. Pop. 1891, 3364.

**Buckingham**, GEORGE VILLIERS, DUKE OF, favourite of James I. and Charles I. of England, was born in 1592, his father being

George Villiers, Knight. At eighteen he was sent to France, where he resided three years, and on his return made so great an impression on James I. that in two years he was made a knight, a gentleman of the bed-chamber, baron, viscount, Marquis of Buckingham, lord high-admiral, &c., and at last dispenser of all the honours and offices of the three kingdoms. In 1623, when the Earl of Bristol was negotiating a marriage for Prince Charles with the Infanta of Spain, Buckingham went with the prince incognito to Madrid to carry on the suit in person in the hope of securing the Palatinate as dowry. The result, however, was the breaking off of the marriage, and the declaration of war with Spain. During his absence Buckingham was created duke. After the death of James in 1625 he was sent to France as proxy for Charles I. to marry the Princess Henrietta Maria. In 1626, after the failure of the Cadiz expedition, he was impeached, but saved by the favour of the king. Despite the difficulty in obtaining supplies Buckingham took upon himself the conduct of a war with France, but his expedition in aid of the Rochelle proved an entire failure. In the meantime the spirit of revolt was becoming more formidable; the Petition of Right was carried despite the duke's exertions; and he was again protected from impeachment only by the king's prorogation of parliament. He then went to Portsmouth to lead another expedition to Rochelle, but was stabbed on Aug. 24, 1628, by John Felton, an ex-lieutenant who had been disappointed of promotion.

**Buckingham**, GEORGE VILLIERS, DUKE OF, son of the preceding, born at Westminster 1627; studied at Trinity College, Cambridge; served in the royal army under Rupert and then went abroad. In 1648 he returned to England, was with Charles II. in Scotland and at the battle of Worcester, and afterwards served as a volunteer in the French army in Flanders. He then returned to England, and in 1657 married the daughter of Lord Fairfax. At the Restoration he became master of the horse and one of the king's confidential *cabal* (1667-73). In 1666, he engaged in a conspiracy, and in 1676 was committed to the Tower for a contempt by order of the House of Lords; but on each occasion he recovered the king's favour. On the death of Charles he retired to his seat in Yorkshire, where he died in 1688. Among his literary compositions the comedy of the Rehearsal (1671) takes the first place.

**Buckingham**, JAMES SILK, English traveller, writer, and lecturer, born near Falmouth, 1786. After trying several professions, and wandering over great part of the world, he came to London, where he established the Athenæum, well known as a literary journal. He also published his journal of travel in Palestine (1822), in Arabia (1825), in Mesopotamia (1827), and in Assyria and Media (1830). In 1832 he was chosen member of parliament for Sheffield, and retained his seat till 1837. Subsequently he made a tour of three years in America. In 1843 he became secretary to the British and Foreign Institute. He also published volumes on his Continental tours and an autobiography. His death took place in 1855.

**Buckingham Palace**, a royal palace in London, facing St. James's Park, built in the reign of George IV., and forming one of the residences of Queen Victoria.

**Buck'land**, FRANCIS TREVELYAN, English naturalist, son of Dr. W. Buckland, born in 1826; studied at Winchester and at Christ Church, Oxford. From 1848 to 1851 he was student, and from 1852 to 1853 house-surgeon, at St. George's Hospital. He became assistant-surgeon in the 2d Life-Guards in 1854. On the establishment of the Field newspaper in 1856 he joined the staff, writing for it until 1865. In 1866 he commenced a weekly journal of his own, Land and Water, and in 1867 was appointed an inspector of salmon fisheries. He died in 1880. His best-known books are his *Curiosities of Natural History* (4 vols 1857-72), the *Logbook of a Fisherman and Zoologist* (1875), and the *Natural History of Fishes* (1881); but there was also a large mass of desultory work showing much natural sagacity.

**Buckland**, REV. WILLIAM, D.D., English geologist, born at Axminster, Devon, in 1784; educated at Winchester and at Corpus Christi College, Oxford, where he held a fellowship from 1808 to 1825. In 1813 he was appointed reader in mineralogy at Oxford; and in 1818 a readership of geology was expressly instituted for him. A paper contributed by him to the *Philosophical Transactions* in 1822, entitled, *Account of an Assemblage of Fossil Teeth and Bones discovered in a Cave at Kirkdale, Yorkshire, in the Year 1821*, procured for him the Copley medal; and on this was founded his *Reliquiæ Diluvianæ*, published in 1823. In 1825 he was presented by his

college to the living of Stoke Charity, Hants, and the same year became one of the canons of Christ Church Cathedral, Oxford. In 1832 he acted as president of the British Association. In 1836 his *Bridge-water Treatise* was published, under the title of *Geology and Mineralogy considered with Reference to Natural Theology*. In 1845 he was made Dean of Westminster, and in 1847 one of the trustees of the British Museum. He died in 1856.

**Buckle**, HENRY THOMAS, English historical writer, born 1822, the son of a wealthy London merchant. At an early age he entered his father's counting-house, but at the age of eighteen, on inheriting his father's fortune, he devoted himself entirely to study. The only thing he allowed to distract him from his more serious pursuits was chess, in which he held a foremost place amongst contemporary players. His chief work, a philosophic *History of Civilization*, of which only two volumes (1858 and 1861) were completed, was characterized by much novel and suggestive thought, and by the bold co-ordination of a vast store of materials drawn from the most varied sources. Three volumes of his *Miscellaneous and Posthumous works* were edited by Helen Taylor in 1872. He died, while travelling, at Damascus, 1862.

**Buckler**, a kind of small shield formerly worn on the left arm, and varying in form and material, among the latter being wicker-work, wood covered with leather, a combination of wood and metal, &c.

**Buck'ram**, a coarse textile fabric stiffened with glue and used in garments to give them or keep them in the form intended.

**Buck-shot**, a kind of large leaden shot used for killing deer or other large game.

**Buck'skin**, a kind of soft leather of a yellowish or grayish colour, made originally from deer-skins, but now usually from sheep-skins. The softness which is its chief characteristic is imparted by using oil or brains in dressing it. The name is also given to a kind of cloth otherwise called doeskin.

**Buck'thorn** (*Rhamnus*), the name of an extensive genus of trees and shrubs, order Rhamnaceæ. Several species belong to N. America. The common buckthorn (*Rhamnus catharticus*), a British and North American shrub, grows to 7 or 8 ft., has strong spines on its branches, elliptical and serrated leaves, male and female flowers on different plants, a greenish-yellow calyx,

no corolla, and a round black berry. It flowers in May. The berries are purgative, but harsh in action. The bark yields a yellow dye, the berries sap green. Dyer's buckthorn (*R. infectorius*) yields French or yellow berries.

**Bucku** (buk'u), the name of several plants belonging to the Cape Colony, genus *Ba-rosma*, order Rutaceæ, used in medicine, in the form of a powder or tincture, in disorders of the urino-genital organs.

**Buck'wheat**, or BRANK (*Fagopyrum esculentum* or *Polygõnum Fagopyrum*), a plant of the order Polygoneæ, with branched herbaceous stem, somewhat arrow-shaped leaves, and purplish-white flowers, growing to the height of about 30 inches, and bearing a small triangular grain of a brownish-black without and white within. The shape of its seeds gives it its German name *Buchweizen*, 'beech-wheat,' whence the English name. The plant was first brought to Europe from Asia by the Crusaders, and hence in France is often called Saracen corn. It grows on the poorest soils. It is cultivated in China and other eastern countries as a bread-corn. In Europe buckwheat has been principally cultivated as food for oxen, swine, and poultry; but in Germany it serves as an ingredient in pottage, puddings, and other food, and in America buckwheat cakes are common.

**Bucyrus**, the seat of Crawford Co., O., 69 miles S. of Toledo; centre of a farming and manufacturing community; celebrated for its mineral springs. Pop. 1890, 5974

**Buczacz** (bö'chäch), a town of Austria, in Galicia, on the Stripa. Pop. 9970.

**Bud**, the name of bodies of various form and structure, which develop upon vegetables, and contain the rudiments of future organs, as stems, branches, leaves, and organs of fructification. Upon exogenous plants they are in their commencement cellular prolongations from the medullary rays, which force their way through the bark. In general, a single bud is developed each year in the axil of each leaf, and there is one terminating the branch called a terminal bud. The life of the plant during winter is stored up in the bud as in an embryo, and it is by its vital action that on the return of spring the flow of sap from the roots is stimulated to renewed activity. Buds are distinguished into leaf-buds and flower-buds. The latter are produced in the axil of leaves called floral leaves or bracts. The terminal bud of a branch is

usually a flower-bud, and as cultivation is capable of producing flower-buds in place of leaf-buds, the one is probably a modification of the other.

**Budapest** (-pesht'), the official name of the united towns of Pest and Buda or Ofen, the one on the right, the other on the left, of the Danube, forming the capital of Hungary, the seat of the imperial diet of the Hungarian ministry and of the supreme court of justice. Buda, which is the smaller of the two, and lies on the west bank of the river, consists of the fortified Upper Town on a hill; the Lower Town or Wasserstadt at the foot of the hill, and several other districts. Among the chief buildings are the royal castle and several palaces, the arsenal, town-hall, government offices, &c., and the finest Jewish synagogue in the empire. The mineral baths of Buda have long been famous, the Bruckbad and Kaiserbad having both been used by the Romans. Pest, or the portion of Budapest on the left or east bank of the river, is formed by the inner town of Old Pest on the Danube, about which has grown a semicircle of districts—Leopoldstadt, Theresienstadt, Elizabethstadt, &c. The river is at this point somewhat wider than the Thames at London, and the broad quays of Pest extend along it for from two to three miles. Pest retains, on the whole, fewer signs of antiquity than many less venerable towns. Its fine frontage on the Danube is modern, and includes the new houses of parliament, the academy, and other important buildings. The oldest church dates from 1500; the largest building is a huge pile used as barracks and arsenal. There is a well-attended university. In commerce and industry Budapest ranks next to Vienna in the empire. Its chief manufactures are machinery, gold, silver, copper, and iron wares, chemicals, silk, leather, tobacco, &c. A large trade is done in grain, wine, wool, cattle, &c. Budapest is strongly Magyar, and as a factor in the national life may almost be regarded as equivalent to the rest of Hungary. It was not until 1799 that the population of Pest began to outdistance that of Buda; but from that date its growth was very rapid and out of all proportion to the increase of Buda. In 1799 the joint population of the two towns was little more than 50,000; in 1886 it was 411,917; in 1890, 506,384.

**Buda'un**, a town of India, N.W. Provinces, consisting of an old and a new town, the former partly surrounded by an-

cient ramparts; there is a handsome mosque, American mission, &c. Pop. 33,680. The district of Budaun has an area of 2000 sq. miles, and a pop. of 906,451.

**Buddha** (bud'ha; 'the Wise' or 'the Enlightened'), the sacred name of the founder of Buddhism, an Indian sage who appears to have lived in the 5th century B.C. His personal name was Siddhartha, and his family name Gautama; and he is often called also Sakya-muni (from *Sakya*, the name of his tribe, and *muni*, a Sanskrit



Buddha.—From a Burmese Bronze.

word meaning a sage). His father was King of Kapilavastu, a few days' journey north of Benares. Siddhartha, filled with a deep compassion for the human race, left his father's court, and lived for years in solitude till he had penetrated the mysteries of life, and become the Buddha. He then began to teach his new faith, in opposition to the prevailing Brahmanism, commencing at Benares. Among his earliest converts were the monarchs of Magadha and Kosala, in whose kingdoms he chiefly passed the latter portion of his life, respected, honoured, and protected. See *Buddhism*.

**Buddhism**, the religious system founded by Buddha, one of the most prominent doctrines of which is that *Nirvâna*, or an absolute release from existence, is the chief good. According to it pain is inseparable from existence, and consequently pain can cease only through *Nirvâna*; and in order to attain *Nirvâna* our desires and passions must be suppressed, the most extreme self-renunciation practised, and we must, as far as possible, forget our own personality. In

order to attain Nirvâna eight conditions must be kept or practised. The first is in Buddhistic language *right view*; the second is *right judgment*; the third is *right language*; the fourth is *right purpose*; the fifth is *right profession*; the sixth is *right application*; the seventh is *right memory*; the eighth is *right meditation*. The five fundamental precepts of the Buddhist moral code are: not to kill, not to steal, not to commit adultery, not to lie, and not to give way to drunkenness. To these there are added five others of less importance, and binding more particularly on the religious class, such as to abstain from repasts taken out of season, from theatrical representations, &c. There are six fundamental virtues to be practised by all men alike, viz. charity, purity, patience, courage, contemplation, and knowledge. These are the virtues that are said to 'conduct a man to the other shore.' The devotee who strictly practises them has not yet attained Nirvâna, but is on the road to it. The Buddhist virtue of charity is universal in its application, extending to all creatures, and demanding sometimes the greatest self-denial and sacrifice. There is a legend that the Buddha in one of his stages of existence (for he had passed through innumerable transmigrations before becoming 'the enlightened') gave himself up to be devoured by a famishing lioness which was unable to suckle her young ones. There are other virtues, less important, indeed, than the six cardinal ones, but still binding on believers. Thus not only is lying forbidden, but evil-speaking, coarseness of language, and even vain and frivolous talk, must be avoided. Buddhist metaphysics are comprised in three theories—the theory of transmigration (borrowed from Brahmanism), the theory of the mutual connection of causes, and the theory of Nirvâna. The first requires no explanation. According to the second, life is the result of twelve conditions, which are by turns causes and effects. Thus there would be no death were it not for birth; it is therefore the effect of which birth is the cause. Again, there would be no birth were there not a continuation of existence. Existence has for its cause our attachment to things, which again has its origin in desire; and so on through sensation, contact, the organs of sensation and the heart, name and form, ideas, &c., up to ignorance. This ignorance, however, is not ordinary ignorance, but the fundamental error which causes us to attribute permanence and reality to things.

This, then, is the primary origin of existence and all its attendant evils. Nirvâna or extinction is eternal salvation from the evils of existence, and the end which every Buddhist is supposed to seek. Sakya-muni did not leave his doctrines in writing; he declared them orally, and they were carefully treasured up by his disciples, and written down after his death. The determination of the canon of the Buddhist scriptures as we now possess them was the work of three successive councils, and was finished two centuries at least before Christ. From Buddhism involving a protest against caste distinctions it was eagerly adopted by the Dasyus or non-Aryan inhabitants of Hindustan. It was pure, moral, and humane in its origin, but it came subsequently to be mixed up with idolatrous worship of its founder and other deities. Although now long banished from Hindustan by the persecutions of the Brahmins, Buddhism prevails in Ceylon, Burmah, Siam, Anam, Tibet, Mongolia, China, Java, and Japan, and its adherents are said to comprise about a third of the human race.

**Buddhist Architecture.** See *India, architecture*.

**Budding**, the art of multiplying plants by causing the leaf-bud of one species or variety to grow upon the branch of another. The operation consists in shaving off a leaf-bud, with a portion of the wood beneath it, which portion is afterwards removed by a sudden jerk of the operator's finger and thumb, aided by the budding-knife. An incision in the bark of the stock is then made in the form of a T; the two side lips are pushed aside, the bud is thrust between the bark and the wood, the upper end of its bark is cut to a level with the cross arm of the T, and the whole is bound up with worsted or other soft fastening, the point of the bud being left exposed. In performing the operation, a knife with a thin flat handle and a blade with a peculiar edge is required. The bud must be fully formed; the bark of the stock must separate readily from the wood below it; and young branches should always be chosen, as having beneath the bark the largest quantity of *cambium* or viscid matter out of which tissue is formed. The maturer shoots of the year in which



Budding.

the operation is performed are the best. The autumn is the best time for budding, though it may also be practised in the spring.

**Budé** (bü-dā), GUILLAUME, or BUDÆUS, a French scholar, born at Paris in 1467, and died in 1540. After a lawless youth he devoted himself to the study of literature. Among his philosophical, philological, and juridical works, his treatise *De Assè* (1514) and his *Commentarii Græcæ Linguae* are of the greatest importance. By his influence the Collège Royal de France was founded.

**Bude Light**, an exceedingly brilliant light, invented by Mr. Gurney of Bude, Cornwall, and produced by directing a current of oxygen into the interior of the flame of an argand-lamp or gas-burner.

**Budg'ell**, EUSTACE, an ingenious writer, author of about three dozen papers, signed 'X,' in the *Spectator*, born 1686, died 1737. He was first cousin to Addison, and went with him to Dublin in 1709 as secretary. On the accession of George I. Budgell obtained several valuable Irish appointments, from which he was removed for an attack on the lord-lieutenant, the Duke of Bolton. He lost three fourths of his fortune in the South Sea Bubble, and spent the rest in a fruitless attempt to get into parliament. Disgraced by an attempted fraud in connection with Dr. Matthew Tindal's will, he committed suicide by drowning in the Thames.

**Budg'et**, the annual financial statement which the British chancellor of the exchequer makes in the House of Commons. It contains a view of the general financial policy of the government, and at the same time presents an estimate of the probable income and expenditure for the following twelve months, and a statement of what taxes it is intended to reduce, increase, or abolish, or what new ones it may be necessary to impose.

**Budha'na**, town of India, North-west Provinces. Pop. 6232.

**Budis'sin**. See *Bautzen*.

**Budweis** (bud'vīs), a city of Bohemia, 75 miles s. of Prague, well built, with a cathedral and episcopal palace, a flourishing trade, and manufactures of earthenware, cloth, machinery, &c. Pop. 23,845.

**Buen Ayre** (bū-en ī'rā), or BONAIR, a small island off the coast of Venezuela, belonging to the Dutch, 50 miles in circumference; produces cattle, goats, poultry, and salt. Pop. 4000.

**Buenos Ayres** (bū-en'ōs ī'rās), a city of

South America, capital of the Argentine Republic, on the s.w. side of the La Plata, 150 miles from its mouth. It was founded in 1535 by Don Pedro de Mendoza, and is built with great regularity, the streets uniformly crossing each other at right angles. It contains the palace of the president, the house of representatives, a town-hall, a number of hospitals and asylums, a cathedral, several monasteries, nunneries, and Catholic and Protestant churches; several theatres, a university, and a custom-house. The university, founded in 1821, is attended by about 800 students. There are also a medical school, normal and other schools, besides literary and scientific societies. There is no harbour, and large vessels can only come within 8 or 9 miles of the town, but extensive harbour works have been begun. The nearest good harbour is at La Plata, a new town 30 miles lower down the estuary, and now (since 1884) the capital of the province. Buenos Ayres is one of the leading commercial centres of South America, its exports and imports together annually amounting to over \$60,000,000. Chief exports are ox and horse hides, sheep and other skins, wool, tallow, horns, &c. There are six railways running from the city, and 100 miles of tramway in the city and suburbs. About one-fourth of the inhabitants are whites; the rest are Indians, negroes, and mixed breeds. Pop. in 1891 by census, 546,980.—The province of Buenos Ayres has an area of about 82,000 sq. miles, and presents nearly throughout level or slightly undulating plains (*pampas*), which afford pasture to vast numbers of cattle and wild horses. These constitute the chief wealth of the inhabitants. Pop. 800,000.

**Buff'alo**, an ungulate or hoofed ruminant mammal, family Bovidæ or oxen, the best-known species of which is the common or Indian buffalo (*Bubālus Buffēlus* or *Bos Bubālus*), larger than the ox and with stouter limbs, originally from India, but now found in most of the warmer countries of the Eastern Continent. A full-grown male is a bold and powerful animal, quite a match for the tiger. The buffalo is less docile than the common ox, and is fond of marshy places and rivers. It is, however, used in tillage, draught, and carriage in India, Italy, &c. The female gives much more milk than the cow, and from the milk the *ghee* or clarified butter of India is made. The hide is exceedingly tough, and a valuable leather is prepared from it, but the

flesh is not very highly esteemed. Another Indian species is the arnee (*B. arni*), the largest of the ox family. The Cape buffalo (*Bubalus Caffer*) is distinguished by the size of its horns, which are united at their



1, Head of Cape Buffalo (*Bubalus Caffer*).  
2, Head of Indian Buffalo (*Bubalus Buffelus*).

bases, forming a great bony mass on the front of the head. It attains a greater size than an ordinary ox. The name is also applied to wild oxen in general, and particularly to the bison of North America. See *Bison*.

**Buff'alo**, city of the United States, New York, at the E. extremity of Lake Erie, the mouth of the Buffalo river, and the head of the Niagara river. It has a water front of  $2\frac{1}{2}$  miles on the lake and of the same extent on the Niagara river, which is here crossed by an iron bridge. The position of Buffalo on the great water and railway channels of communication between the west and the east makes it the centre of a vast trade in grain, live stock, and other commodities. The harbour is capacious, and is protected by extensive breakwaters. The Erie Canal, which connects with the Hudson, has its western terminus here. The whole site is a plain with a gentle descent towards the lake, well covered with houses, except where open spaces or squares have been left for ornament and ventilation. There is a splendid public park. The principal buildings are the city and county hall, the custom-house and post-office, the arsenal, and many of the churches; other buildings and institutions of note are: a young men's literary association with a library of above 40,000 volumes, an orphan asylum, a general hospital, and a fine cemetery covering about 76 acres. Manufactures are numerous and varied, con-

sisting of machinery and iron goods, agricultural implements, leather, &c. Pop. in 1880, 155,134; in 1890, 255,664.

**Buffalo-berry** (*Shepherdia argentæa*), a shrub of the oleaster family, a native of the States and Canada, with lanceolate silvery leaves and close clusters of bright-red acid berries about the size of currants, which are made into preserves and used in various ways.

**Buffalo-grass** (*Tripsacum dactyloides*), a strong-growing N. American grass, so called from forming a large part of the food of the buffalo, and said to have excellent fattening properties: called also *gama-grass*.

**Buffer**, any apparatus for deadening the concussion between a moving body and the one on which it strikes. In railway-carriages they are placed in pairs at each end, and are fastened by rods to springs under the frame-work, to deaden the concussions caused when the velocity of part of the train is checked.

**Buffet**, a cupboard, sideboard, or closet to hold china, crystal, plate, and the like. The word is also very commonly applied to the space set apart for refreshments in public places.

**Buff Leather**, a sort of leather prepared from the skin of the buffalo and other kinds of oxen, dressed with oil, like shammy. It is used for making bandoliers, belts, pouches, gloves, and other articles.

**Buffon** (bû-fōn), GEORGE LOUIS LECLERC, COUNT DE, celebrated French naturalist, was born at Montbard, in Burgundy, 1707; died in Paris 1788. Being the son of a rich man he was able to travel, and he visited Italy and England. In 1739 he was appointed superintendent of the Royal Garden at Paris (now the Jardin des Plantes), and devoted himself to the great work on Natural History, which occupied the most of his life. It is now obsolete and of small scientific value, but it for long had an extraordinary popularity, and was the means of diffusing a taste for the study of nature throughout Europe. After an assiduous labour of ten years the three first volumes were published, and between 1749 and 1767 twelve others, which comprehend the theory of the earth, the nature of animals, and the history of man and the mammalia. In these Buffon was assisted by Daubenton in the purely anatomical portions. The nine following volumes, which appeared from 1770 to 1783, contain the history of birds, from which Daubenton withdrew his assistance, the author being now aided by Guéneau de Montbelliard, and

afterwards by the Abbé Bexon. Buffon published alone the five volumes on minerals, from 1783 to 1788. Of the seven supplementary volumes, of which the last did not appear until after his death in 1789, the fifth formed an independent whole, the most celebrated of all his works. It contains his Epochs of Nature, in which the author gives a second theory of the earth, very different from that which he had traced in the first volumes, though he assumes at the commencement the air of merely defending and developing the former. Buffon was raised to the rank of count by Louis XV., whose favour, as also that of Louis XVI., he enjoyed. His works were translated into almost every European language.

**Buffoon'**, a merry-andrew, a clown, a jester; from the Ital. *buffone*, from *buffare*, to jest, to sport. *Buffo*, in Ital., is the name given to a comic actor; a burlesque play is called a *commedia buffa*, and a comic opera *opera buffa*. The Italians, however, distinguish the *buffo cantante*, which requires good singing, from the *buffo comico*, in which there is more acting.

**Bufo**'idæ, a family of tailless batrachians, comprehending the toads.

**Bug**, or **BOG**, a river in European Russia, which falls into the estuary of the Dnieper near Kherson, after a course of about 500 miles. Another river of same name, the Western Bug, rises in Galicia, and falls into the Vistula about 20 miles N.N.W. of Warsaw. Both are navigable for considerable distances.

**Bug**, a name given to the *Cimex lectularius*, otherwise known as the house-bug or bed-bug, or any member of this genus or of the family Cimicidæ. The common bug is about  $\frac{3}{16}$  inch long, wingless, of a roundish depressed body, dirty rust colour, and emits an offensive smell when touched. The female lays her eggs in summer in the crevices of bedsteads, furniture, and walls of rooms. Its larvæ are small, white, and semi transparent. They attain full size in eleven weeks. The mouth of the bug has a three-jointed proboscis, which forms a sheath for a sucker. It is fond of human blood, but eats various other substances. The name was formerly applied loosely to insects of various kinds, and in the United States it is generally used where *beetle* would be used in England.

**Bugeaud** (bü-zhō), THOMAS ROBERT, DUKE D'ISLY, a marshal of France, born in 1784, died at Paris 1849. He entered the

army in 1804 as a simple grenadier, but rose to be colonel before the fall of Napoleon. After the revolution of 1830 he obtained a seat in the Chamber of Deputies. He was afterwards sent to Algeria, where he gained many advantages over the Arabs. On the revolution of 1848 he adhered to Louis Philippe to the last. Under the presidency of Louis Napoleon he was appointed commander-in-chief of the army of the Alps.

**Bugenhagen** (bö'gen hū-gen), JOHANN, German reformer, friend and helper of Luther in preparing his translation of the Bible. He was born in 1485, and died in 1558. He fled from his Catholic superiors to Wittenberg in 1521, where he was made, in 1522, professor of theology. He effected the union of the Protestant free cities with the Saxons, and introduced into Brunswick, Hamburg, Lübeck, Pomerania, Denmark, and many other places, the Lutheran service and church discipline. He translated the Bible into Low German (Lübeck, 1533); wrote an Exposition of the Book of Psalms and a History of Pomerania.

**Buggy**, a name given to several species of carriages or gigs: in England, a light one-horse two-wheeled vehicle without a hood; in the U. States, a light one-horse four-wheeled vehicle, with or without a hood or top; in India, a gig with a large hood to screen those who travel in it from the sun's rays.

**Bugis** (bö'giz), a people of the Indian Archipelago, chiefly inhabiting the eastern coast and a good deal of the interior of the southern peninsula of the island of Celebes, their chief town being Boni. They are described as peaceable, orderly, and well-behaved, are the chief carriers and factors of the Indian seas, and are engaged in the manufacture of iron, copper, cotton, &c., and in trepang, pearl, and other fisheries. Large communities of them have also been formed in Borneo, in Sumatra, and in many small islands of the archipelago.

**Bu'gle**, a military musical brass wind-instrument of the horn kind, sometimes furnished with keys or valves. It is used in the British and other armies to sound signal-calls. The name is an abbreviation of *bugle-horn*, that is, buffalo-horn, from O.E. *bugle*, a buffalo.

**Bugle**, the common name for *Ajuga*, a genus of labiate plants. Two of the species are British, *A. reptans*, a hedge-side plant with dark leaves and purplish flowers,



formerly held in high esteem as an application to wounds; and *A. chamæpitys*, yellow bugle, a plant which grows in sandy fields, rare in the United States.

**Bugle**, a shining elongated glass bead, usually black, used in decorating female apparel and also in trafficking with savage tribes.

**Bu'gloss**, a popular name applied to a number of plants of the natural order Boraginæ, and in particular to the alkanet (which see).

**Buhl-work** (böl-), a description of inlaid work, said to have been invented by Boule, a French cabinet-maker, in the reign of Louis XIV. It consisted at first of unburnished gold, brass, enamel, or mother-of-pearl worked into complicated and ornamental patterns, and inserted in a ground of dark-coloured metal, wood, or tortoise-shell; but at a later period the use of wood of a different colour was introduced by Reisner, and to his process the modern practice of buhl-work is chiefly confined.

**Buhrstone** (bör-), BURRSTONE, a name given to certain siliceous or siliceo-calcareous stones, whose dressed surfaces present a burr or keen-cutting texture, whence they are much used for millstones. The most esteemed varieties are obtained from the upper fresh-water beds of the Paris basin, and from the Eocene strata of South America.

**Building Lease**, a lease of land for a long term of years, usually 99 years, at a rent called a ground-rent, the lessee covenanting to erect certain edifices thereon, and to maintain the same during the term. At the expiration of the lease the houses built become the absolute property of the landlord. In Scotland it is called a *feu*, and the price assumes the shape of an annual feu-duty.

**Building Societies**, joint-stock benefit societies for the purpose of raising by periodical payments a fund to assist members in obtaining small portions of landed property and houses, which are mortgaged to the society till the amount of the shares drawn on shall be fully repaid with interest. The stock is divided into shares, valued at \$200 each, payable in monthly instalments of \$1 for each share. In most societies the money is loaned to the member bidding the highest premium for its use, which premium is in some cases deducted at once, in others is paid in monthly instalments. The interest on money bor-

rowed, at the rate of six per cent. per annum, is payable monthly. Building societies are of two chief kinds, either confined to a certain number of members, or permanent and not confined to any definite number of members, but ready to receive new members as long as the society exists. These series societies, by the admission of new members, have a constant supply of funds at their disposal, and are thus able to supply the demands of all the borrowers; while the security offered to investors induces many people to enter the society merely with the view of having a convenient means of depositing their savings, and not with the intention of acquiring any real estate for themselves. In the United Kingdom, since building societies were legalized in 1836, more than \$500,000,000 has been raised by their means, and applied by their members for the acquiring of houses and lands—nearly half a million persons being assisted in buying their homes. In the U. States a statistical statement of the Bureau of Labour gives as in operation 5860 societies, with 2,000,000 members and assets of nearly \$900,000,000. This large accumulation is the result of 12 years' savings. Besides other advantages the building society gives to its members business training, accustoms them to invest sums of money, and thus fits them to take care of their earnings.

**Buitenzorg** (boi'ten-zorg; 'without care'), a favourite residential town in the island of Java, about 40 miles south of Batavia, with which it is connected by rail. It contains a fine palace of the governor-general, celebrated botanic gardens, &c.

**Bujalance** (bö-hâ-lân'thā), a city, Spain, Andalusia, 21 miles E. by N. Cordova; manufactures cloth and woollen fabrics, earthenware, and glass. Pop. 9974.

**Bukarest'**, the capital of Roumania, situated on the Dimbovitza about 33 miles north of the Danube, in a fertile plain. It is in general poorly built, among the chief buildings being the royal palace, the National Theatre, the university buildings, the National Bank, the Mint, and the Archbishopal church. There are handsome public gardens. Manufactures are varied but unimportant; the trade is considerable, the chief articles being grain, wool, honey, wax, wine, hides. The mercantile portion of the community is mostly foreign, and the whole population presents a curious blending of nationalities. Bukarest became the capital of Walachia in 1665, in 1862 that of the

united principalities of Walachia and Moldavia. A treaty was concluded here in 1812 between Turkey and Russia by which



A Street in Bukarest.

the former ceded Bessarabia and part of Moldavia. Pop. 1890, 221,805.

**Bukowina** (bö-ko-vē'nā), an Austrian duchy, forming the s. e. corner of Galicia. Area, 4035 sq. miles; pop. 1891, 646,591. It is traversed by ramifications of the Carpathians, and much of the surface is occupied with swamps and forests. Chief town, Czernowitz.

**Bulac'**, or **BULAK'**. See *Boulak*.

**Bulacan'**, a town, Philippines, island of Luzon, about 22 miles n.w. of Manila; chief industries: sugar-boiling and the manufacture of silken mats. Pop. about 10,000.

**Bula'ma**, **BOLA'MA**, an island on the w. coast of Africa, one of the Bissagos (which see).

**Bulandshahr** (bū-land-shär'), a district of British India, North-western Provinces, forming a portion of the Doáb, or alluvial plain inclosed between the Ganges and the Jumna. Cotton, indigo, sugar, &c., form the chief products of the district. Area, 1914 sq. miles; pop. 924,822. The town *Bulandshar*, the administrative headquarters of the district, has a pop. of 17,863.

**Bu'lau**, or **TIKUS**, an animal of the mole family (*Talpidae*) and genus *Gymnura* (*G. Rafflesii*), a native of Sumatra and Malacca, bearing a considerable resemblance to the opossum. The muzzle is much prolonged, the fur pierced by a number of long hairs or bristles, the tail naked, and it is possessed of glands which secrete a kind of musk.

**Bulb**, a modified leaf-bud, formed on a plant upon or beneath the surface of the ground, emitting roots from its base, and producing a stem from its centre. It is formed of imbricated scales or of concentric coats or layers. It incloses the rudiments of the future plant and a store of food to nourish it. Examples of bulbs are the onion, lily, hyacinth, &c.

**Bulbul** (bul'bul'), the Persian name of the nightingale, or a species of nightingale, rendered familiar in English poetry by Moore, Byron, and others. The same name is also given in southern and south-western Asia to sundry other birds.

**Bulga'ria**, a principality tributary to Turkey, constituted by the first article of the Treaty of Berlin, July 13, 1878, and placed under the suzerainty of the sultan. It is bounded north by Roumania and the Dobrudsha, east by the Black Sea, south by the Balkan Mountains, which separate it from Eastern Rumelia, and west by Servia. The principal towns are Widdin, Sofia, Plevna, Sistova, Tirnova, Rustchuk, Shumla, Varna, and Silistria. The country almost wholly belongs to the north slope of the Balkans, and is intersected by streams flowing from that range to the Danube. It possesses much good agricultural land and a good climate; but cultivation is backward, though the rearing of cattle and horses is successfully carried on. Agricultural produce is exported, manufactured goods imported. Education is backward, but is improving; four years' school attendance is obligatory in principle. The prevalent religion is that of the Greek Church. The revenue and expenditure are each about £1,189,000. Military service is obligatory; the war strength of the army is about 100,000. In accordance with the terms of the Treaty of Berlin a constitution was drawn up for the new principality by an assembly of Bulgarian notables at Tirnova in 1879. By this constitution the legislative authority is vested in a single chamber, called the Sobranje or National Assembly, the members of which are partly elected by universal manhood suffrage, partly nominated by the prince. On the 29th of April, 1879, Prince Alexander of Battenberg, cousin of the Grand-duke of Hesse, was elected prince by unanimous vote of the constituent assembly. In 1885 a national rising took place in Eastern Rumelia, the Turkish governor was expelled, and union with Bulgaria proclaimed. In consequence Servia demanded an addition

to her own territory, and began a war against Bulgaria (Nov. 1885), in which she was severely defeated. By the treaty which followed, the Prince of Bulgaria was appointed governor-general of Eastern Rume-  
lia for a term of five years, to be renomi-  
nated at the end of that time by sanction  
of the great powers. These events greatly  
irritated Russia, whose agents managed to  
seduce certain regiments of Bulgarians; and  
in August, 1886, the prince was seized and  
carried off, while a proclamation was issued  
to the effect that he had abdicated. When  
he was set free on Austrian territory he  
discovered that the people were still with  
him, and determined to return. Seeing,  
however, that his presence would cause an  
immediate interference on the part of Rus-  
sia he formally abdicated and left the coun-  
try (7th Sep. 1886). In 1887 Prince Fer-  
dinand of Saxe-Coburg accepted an invita-  
tion to occupy the throne; but his position  
is insecure, as the great powers have not  
sanctioned the step taken by him. The area  
of Bulgaria proper is about 24,400 square  
miles, the population in 1890 was 2,179,375.  
Eastern Rumelia has an area of 13,500  
sq. miles; a pop. of over 975,000.

**Bulgarians**, a race of Finnish origin,  
whose original seat was the banks of the  
Volga, and who subdued the old Mœsian  
population and established a kingdom in  
the present Bulgaria in the 7th century.  
They soon became blended with the con-  
quered Slavs, whose language they adopted.  
In the 14th century the country was con-  
quered by the Turks, and has until lately  
remained part of the Ottoman Empire. (See  
*Bulgaria*.) The Bulgarian language is di-  
vided into two dialects, the old and the new;  
the former is the richest and best of the  
Slavonic tongues, and although extinct as a  
living tongue is still used as the sacred lan-  
guage of the Greek Church. The Bulgari-  
ans are now spread over many parts of the  
Balkan peninsula.

**Bulim'ia**, morbidly voracious appetite; a  
disease in which the patient has a perpetual  
and insatiable appetite for food.

**Bulk-heads**, partitions built between the  
several portions of the interior of a ship,  
whether to separate it into rooms, or as a  
safeguard in case of wreck.

**Bull** (Lat. *bul-la*, a boss, later a leaden  
seal), a letter, edict, or rescript of the pope,  
published or transmitted to the churches  
over which he is head, containing some de-  
cree, order, or decision, and in many cases

having a leaden seal attached, impressed on  
one side with the heads of St. Peter and St.  
Paul, on the other with the name of the  
pope. The document is in Latin and on  
parchment.

**Bull**, the name given to the male of any  
bovine quadruped.

**Bull, JOHN**, the English nation personified,  
and hence any typical Englishman: first  
used in Arbuthnot's satire, *The History of  
John Bull*, designed to ridicule the Duke of  
Marlborough; and in which the French are  
personified as *Lewis Baboon*, the Dutch as  
*Nicholas Frog*, &c.

**Bull, OLE BORNEMANN**, famous violinist,  
born at Bergen, in Norway, 1810; died 1880.  
He secured great triumphs both throughout  
Europe and in America by his wonderful  
playing. He lost all his money in a scheme  
to found a colony of his countrymen in  
Pennsylvania, and had to take again to his  
violin to repair his broken fortunes. He  
afterwards settled down at Cambridge, Mass.,  
and had also a summer residence in Norway,  
where he died.

**Bullace** (bul'ās), a kind of wild plum  
(*Prunus insititia*) common in many parts  
of England and naturalized in Massachu-  
setts, used for making jam, &c.

**Bull-baiting**, the barbarous sport of set-  
ting dogs on a bull, who is tied to a stake  
and worried by the dogs for the amusement  
of the spectators. It was a favourite sport  
in England from a very early period till it  
was finally put down by act of parliament  
in 1835.

**Bull-dog**, a variety of the common dog,  
remarkable for its short, broad muzzle, and  
the projection of its lower jaw, which causes  
the lower front teeth to protrude beyond  
the upper. The head is massive and broad;  
the lips are thick and pendulous; the ears  
pendent at the extremity; the neck robust  
and short; the body long and stout; and  
the legs short and thick. The bull-dog is  
a slow-motioned ferocious animal, better  
suited for savage combat than for any pur-  
pose requiring activity and intelligence.  
For this reason he is often employed as a  
watch-dog. It was formerly used—as its  
name implies—for the barbarous sport of  
bull-baiting.—The *bull terrier* was origi-  
nally from a cross between the bull-dog and  
the terrier. It is smaller than the bull-dog,  
lively, docile, and very courageous.

**Bullen, ANNE**. See *Boleyn*.

**Bullers of Buchan** (bul'ers), a natural  
curiosity on the coast of Aberdeenshire, 5¼ m.

s.s.w. of Peterhead, consisting of a series of huge granite cliffs, with a large rocky caldron into which the sea rushes through a natural archway in the top of which is an opening locally called 'the pot.'

**Bullet** (bul'et), a projectile intended to be discharged from firearms or other missile weapons; more especially, one for a rifle, musket, fowling-piece, pistol, or similar firearm. Bullets used to be solid spherical masses, but of late many changes have been made on their shape and structure. Bullets used for rifles of recent construction are elongated and generally rounded, conical, or ogival at the apex, somewhat like half an egg drawn out, often with a hollow at the base, into which a plug of wood or clay is inserted. When the rifle is fired the plug is driven forward, forcing the base of the bullet outward till the lead catches the grooves of the barrel.

**Bulletin** (bul'e-tin), an authenticated official report concerning some public event, such as military operations, the health of the sovereign or other distinguished personage, issued for the information of the public. The name is also given to some periodical publications recording the proceedings of learned societies.

**Bullet-tree**, or BULLY-TREE (*Mimūsops balāta* or *Sapōta Mullēri*), a forest tree of Guiana and neighbouring regions, order Sapotaceæ, yielding an excellent gum (the concreted milky juice) known as *balata*, having properties giving it in some respects an intermediate position between gutta-percha and india-rubber, and making it for certain industrial purposes more useful than either. In the U. States it is used as a chewing material. The timber of the tree also is valuable.

**Bull-fights** are among the favourite diversions of the Spaniards. They are usually held in an amphitheatre having circular seats rising one above another, and are attended by vast crowds who eagerly pay for admission. The combatants, who make bull-fighting their profession, march into the arena in procession. They are of various kinds—the *picadores*, combatants on horseback, in the old Spanish knightly garb; the *chulos* or *banderilleros*, combatants on foot, in gay dresses, with coloured cloaks or banners; and lastly, the *matador* (the killer). As soon as the signal is given the bull is let into the arena. The *picadores*, who have stationed themselves near him, commence the attack with their lances, and the bull is

thus goaded to fury. Sometimes a horse is wounded or killed (only old worthless animals are thus employed), and the rider is obliged to run for his life. The *chulos* assist the horsemen by drawing the attention of the bull with their cloaks; and in case of danger they save themselves by leaping over the wooden fence which surrounds the arena. The *banderilleros* then come into play. They try to fasten on the bull their *banderillas*—barbed darts ornamented with coloured paper, and often having squibs or crackers attached. If they succeed, the squibs are discharged, and the bull races madly about the arena. The *matador* or *espada* now comes in gravely with a naked sword, and a red flag to decoy the bull with, and aims a fatal blow at the animal. The slaughtered bull is dragged away, and another is let out from the stall. Several bulls are so disposed of in a single day.

**Bullfinch**, an insessorial bird, *Pyrrhūla rubicilla*, family Fringillidæ or finches, with short thick rounded bill, beak and crown of the head black, body bluish-gray above and bright tile-red below. It occurs in Britain, in the middle and south of Europe, and in Asia, and when tamed may be taught to sing musical airs. *P. synoica* is an Asiatic species, and *P. cineriola* an inhabitant of Brazil.

**Bull-frog**, the *Rana pipiens*, a large species of frog found in North America, 8 to 12 inches long, of a dusky-brown colour mixed with a yellowish green, and spotted with black. These frogs live in stagnant water, and utter a low croaking sound resembling the lowing of cattle, whence the name.

**Bull-head**, the popular name of certain fishes. One of these, the *Cottus gobio*, a British fish, is about 4 inches long, with head very large and broader than the body. It is often called also *Miller's-thumb*. The armed bull-head is the *Aspidophōrus europæus*, found in the Baltic and northern seas; the six-horned bull-head (*C. hexacornis*) is a North American species. In America this name is given to a species of *Pimelōdus*, called also *Cat-fish* and *Horned-pout*.

**Bullinger** (bul'ing-ēr), HENRY, a celebrated Swiss reformer, born in 1504, died at Zurich 1575. He was the intimate friend of Zuinglius, whom he succeeded in 1531 as pastor of Zurich. He kept up a close correspondence with the principal English reformers. The Zurich Letters, published by the Parker Society, contains part of this correspondence, and among others, letters

addressed to him by Lady Jane Grey. He wrote numerous theological works.

**Bull'ion** is uncoined gold or silver, in bars, plate, or other masses, but the term is frequently employed to signify the precious metals coined and uncoined.

**Bull Run**, a stream in the N.E. of Virginia, flowing into the Occoquan river, 14 miles from the Potomac; the scene of two great battles during the American civil war in which the Federals were defeated. The first battle was fought 21st July, 1861; and the second on 29th and 30th August, 1862.

**Bulls and Bears**, in stock-exchange slang, manipulators of stocks; the former operating in order to effect a rise in price, the latter doing all they can to bring prices of stock down.

**Bull's-eye**, (1) a round piece of thick glass, convex on one side, inserted into the decks, ports, scuttle-hatches, or skylight-covers of a vessel for the purpose of admitting light. (2) A small lantern with a lens in one side of it to concentrate the light in any desired direction. (3) In *rifle shooting*, the centre of a target, of a different colour from the rest of it and usually round.

**Bull-trout**, a large species of fish of the salmon family, the *Salmo eriox*, thicker and clumsier in form than the salmon, but so like it as sometimes to be mistaken for it by fishers. It attains a weight of 15 to 20 lbs., and lives chiefly in the sea, ascending rivers to spawn. Its scales are smaller than those of the salmon, and its colour less bright.

**Bully-tree**. See *Bullet-tree*.

**Bülow** (bü'lō), FRIEDRICH WILHELM VON, Prussian general, born 1755, died 1816. He was actively engaged against the French at the earliest periods of the revolutionary war; and his services in 1813 and 1814, especially at Grosbeeren and Dennewitz, were rewarded with a Grand Knightship of the Iron Cross and the title Count Bülow von Dennewitz. As commander of the fourth division of the allied army he contributed to the victorious close of the battle of Waterloo.

**Bülow** (bü'lō), HANS GUIDO VON, pianist and composer, born at Dresden 1830; was intended for a lawyer, but adopted music as a profession. He studied the piano under Liszt, and made his first public appearance in 1852. In 1855 he became leading professor in the Conservatory at Berlin; in 1858 was appointed court pianist; and in 1867 he became musical director to the

King of Bavaria. His compositions include overture and music to Julius Cæsar, The Minstrel's Curse, and Nirwana; songs, choruses, and pianoforte pieces. He is considered one of the first of pianists and orchestral conductors.

**Buloz** (bü-loz), FRANÇOIS, born near Geneva, Switzerland, 1803, died at Paris 1877; founder and editor of the *Revue des Deux Mondes*, the celebrated French fortnightly literary magazine.

**Bulrampur** (bal-räm'pur), a town of Oude, India; the largest town in the Gonda district, and the residence of the Maharajah of Bulrampur. Pop. 12,811.

**Bulrush** (bul'-), the popular name for large rush-like plants growing in marshes, not very definitely applied. Some authors apply the name to *Typha latifolia* and *T. angustifolia* (cat's-tail or reed-mace). But it is more generally restricted to *Scirpus lacustris*, a tall rush-like plant from which the bottoms of chairs, mats, &c., are manufactured. The bulrush of Egypt (Ex. ii. 3) is the *Juncus globulosus*.

**Bulsar'**, port and town in Surat district, Bombay, on the estuary of the Auranga. Exports timber, and manufactures cloth, bricks, tiles, and pottery. Pop. 13,229.

**Bulwark**, an old name for a rampart or bastion.

**Bulwer** (bul'-), SIR HENRY LYTTON, LORD DALLING and BULWER, diplomatist and author, elder brother of Lord Lytton, born 1804, died 1872. He was attached to the British embassies at Berlin, Brussels, and the Hague from 1827 to 1830, when he entered parliament. In 1837 he was sent as secretary of legation to Constantinople; subsequently he was minister at Madrid and Washington, and he succeeded Lord Stratford de Redcliffe as ambassador at the Porte (1858-65). He wrote, among others, *France, Social, Literary, and Political*; *Life of Byron*, *Life of Palmerston*, and *Historical Characters*. He was raised to the peerage in 1871.

**Bulwer Lytton**. See *Lytton, Lord*.

**Bum-boat**, a small boat used to sell vegetables, &c., to ships lying at a distance from shore.

**Bum'malo**, BUMMALO'TI, the Indian name for a small glutinous, transparent fish, about the size of a smelt, found on the coasts of Southern Asia, which, when dried, is much used as a relish by both Europeans and Indians, and facetiously called *Bombay-duck*. It is the *Saurus ophiodon*, family Scopelidæ.

**Buncombe**, BUNKUM, a county in North Carolina; area 450 sq. m. Pop. 21,910. The term *Bunkum*, meaning talking for talking's sake, bombastic speech-making, is said to have originated with a congressional member for this county, who declared that he was only talking for *Buncombe*, when attempts were made to cut his oratory short.

**Bundelcund** (more correctly BUNDELKHAND), a tract of country in Upper India lying between the river Jumna on the N., and the Chambal on the N. and W.; area 20,559 sq. m., pop. 3,622,982. It comprises the British districts of Hamirpur, Jalaun, Jhānsi, Lalitpur, and Banda, and thirty-one native states.

**Bunder-Abbas.** See *Bender-Abbas*.

**Bundesrath** (bun'des-rät), the German federal council which represents the individual states of the empire, as the *Reichstag* represents the German nation. It consists of sixty-two delegates, and its functions are mainly those of a confirming body, although it has the privilege of rejecting measures passed by the Reichstag.

**Bundi.** See *Boondec*.

**Bun'galow**, in India, a house or residence, generally of a single floor. Native bun-



Bungalow on Penang Hills.

galows are constructed of wood, bamboos, &c.; but those erected by Europeans are generally built of sun-dried bricks, and thatched or tiled, and are of all styles and sizes, but invariably surrounded by a verandah.

**Bun'gay**, a market town, England, county Suffolk, on the right bank of the Waveney, 30 miles N.E. of Ipswich. It contains the ruins of an ancient castle, a stronghold of the Bigods, earls of Norfolk. Pop. 5855.

**Bun'ion**, an enlargement and inflammation of the joint of the great toe arising from irritation of the small membranous sac called *bursa mucosa*.

**Bu'nium.** See *Earth-nut*.

**Bunk**, a wooden box or case serving as a seat during the day and a bed at night; also one of a series of sleeping berths arranged above each other.

**Bunker Hill**, a small eminence in Charlestown, now a part of Boston, Mass.; scene of the first important battle in the revolutionary war, fought June 17, 1775. A considerable body of Americans having been sent to occupy the peninsula on which Charlestown stands, a British force was sent to dislodge them. This was not effected till after three assaults on their intrenched position, with a loss of 1000 men, while the Americans did not lose half that number.

**Bunkum.** See *Buncombe*.

**Bunsen** (bun'sen), CHRISTIAN KARL JOSIAS, CHEVALIER, a distinguished German diplomatist and scholar, was born at Korbach, in the principality of Waldeck, 1791; died 1860. In 1815 he made the acquaintance of Niebuhr, who shortly after procured for him the post of secretary to the Prussian embassy at Rome. In 1824 he was appointed chargé d'affaires, and afterwards minister. After a stay of twelve years in Rome he was sent, as Prussian minister, first to Switzerland, and then to England, where he remained till the breaking out of the Eastern difficulty in 1854. In his official capacity he won the esteem of all, and with Britain especially he was connected by many ties. His later years were spent at Heidelberg and at Bonn exclusively in literary pursuits. Among his best-known works are *Die Verfassung der Kirche der Zukunft* (The Constitution of the Church of the Future), Hamburg, 1845; *Aegyptens Stelle in der Weltgeschichte* (Egypt's Place in the World's History), Hamburg, 1845; *Hippolytus und seine Zeit* (Hippolytus and his Time), London, 1851; and lastly, his greatest work, *Bibelwerk für die Gemeinde* (Bible Commentary for the Community), the publication of which was unfinished at his death. His *Memoirs*, by his widow, were published in 1868.

**Bunsen**, ROBERT WILHELM EBERARD, eminent German chemist, born at Göttingen 1811. He studied at Göttingen University, and at Paris, Berlin, and Vienna; was appointed professor at the Polytechnic Institute of Cassel, 1836; at the University of Marburg in 1838, at Breslau in 1851, and finally professor of Experimental Chemistry at Heidelberg in 1852. Among his many discoveries and inventions are the produc-

tion of magnesium in quantities, magnesium light, spectrum analysis, and the electric pile and the burner which bear his name.

**Bunsen's Battery**, a form of galvanic battery, the cells of which consist of cleft cylinders of zinc immersed in dilute sulphuric acid, and rectangular prisms of carbon in nitric acid, with an intervening porous cell of unglazed earthenware.

**Bunsen's Burner**, a form of gas burner especially adapted for heating, consisting of a tube, in which, by means of holes in the side, the gas becomes mixed with air before consumption, so that it gives a non-illuminating smokeless flame.

**Bunt**, sometimes called *Smut Ball*, *Pepper Brand*, and *Brand Bladders*, a fungoid disease incidental to cultivated corn, consisting of a black powdery matter, having a disagreeable odour, occupying the interior of the grain of wheat and a few other Gramineæ. This powdery matter consists of minute balls filled with sporules, and is caused by the attack of *Tilletia caries*, a kind of mould.

**Bunter Sandstein** (bun'tēr zānt'shtīn; 'variegated sandstone'), a German name for the new red sandstone, the lowest group of the Triassic system.

**Bunt'ing**, the popular name of a number of insectorial birds, family Emberizidæ, chiefly included in the genus *Emberiza*; such as the English or common bunting; the rice-bunting; the Lapland, snow, black-headed, yellow, curl, and ortolan buntings. The yellow-bunting or yellow-hammer (*E. citrinella*) is one of the most common British birds. The common or corn bunting (*E. miliaria*) is also common in cultivated districts. The snow-bunting (*Plectrophanes nivālis*) is one of the few birds which cheer the solitudes of the polar regions.

**Bunt'ing**, a thin woollen stuff, of which the colours and signals of a ship are usually formed; hence, a vessel's flags collectively.

**Bunya-Bunya**, the native Australian name of the *Araucaria Bidwillii*, a fine Queensland tree with cones larger than a man's head, containing seeds that are eagerly eaten by the blacks.

**Bun'yan**, JOHN, author of the *Pilgrim's Progress*, was the son of a tinker, and was born at the village of Elstow, near Bedford, in 1628, died in London 1688. He followed his father's employment, but during the civil war he served as a soldier. Returning to Elstow, after much mental conflict his mind became impressed with a deep sense

of the truth and importance of religion. He joined a society of Anabaptists at Bedford, and at length undertook the office of a public teacher among them. Acting in defiance of the severe laws against dissenters, Bunyan was detained in prison for twelve years (1660-72), but was at last liberated, and became pastor of the community with which he had previously been connected. During his imprisonment he wrote *Profitable Meditations*, *The Holy City*, &c., and also the curious piece of autobiography entitled *Grace Abounding to the Chief of Sinners*. In 1675 he was sent to prison for six months under the Conventicle Act. To this confinement he owes his chief literary fame, for in the solitude of his cell he produced the first part of that admired religious allegory, the *Pilgrim's Progress*. His *Holy War*, his other religious parables, and his devotional tracts, which are numerous, are also remarkable, and many of them valuable. On obtaining his liberty Bunyan resumed his functions as a minister at Bedford, and became extremely popular. He died when on a visit to London.

**Bunzlau** (bun'ts'lou), a town, Prussia, province of Silesia, 28 miles w. of Liegnitz. Industries: woollen and linen, pottery. Pop. 10,790.—*Jung-Bunzlau* is a town of Bohemia, 31 miles N.E. of Prague, with 9681 inhabitants.

**Buonaparte**. See *Bonaparte*.

**Buonarotti** (bū-o-nā-rot'tē), MICHAEL ANGELO, of the ancient family of the counts



Michael Angelo Buonarotti.

of Canossa, born at Caprese, in Tuscany, 1475, died at Rome 1563; a distinguished Italian painter, sculptor, architect, and poet.

He studied drawing under Domenico Ghirlandaio, and sculpture under Bertoldo at Florence, and having attracted the notice of Lorenzo de' Medici, was for several years an inmate of his household. Having distinguished himself both in sculpture and painting, he was commissioned (together with Leonardo da Vinci) to decorate the senate-hall at Florence with a historical design, but before it was finished, in 1505, he was induced by Pope Julius II. to settle in Rome. Here he sculptured the monument of the pontiff (there are seven statues belonging to it) now in the church of St. Pietro in Vincoli; and painted the dome of the Sistine Chapel, his frescoes representing the creation and the principal events of sacred history. In 1530 he took a leading part in the defence of Florence against Charles V. Three years later he began his great picture in the Sistine Chapel, the Last Judgment, which occupied him eight years. His last considerable works in painting were two large pictures: the Conversion of St. Paul and the Crucifixion of St. Peter in the Pauline Chapel. In sculpture he executed the Descent of Christ from the Cross, four figures of one piece of marble. His statue of Bacchus was thought by Raphael to possess equal perfection with the masterpieces of Phidias and Praxiteles. As late as 1546 he was obliged to undertake the continuation of the building of St. Peter's, and planned and built the dome, but he did not live long enough to see his plan finished, in which many alterations were made after his death. Besides this, he undertook the building of the Piazza del Campidoglio (Capitol), of the Farnese Palace, and of many other edifices. His style in architecture is distinguished by grandeur and boldness, and in his ornaments the untamed character of his imagination frequently appears, preferring the uncommon to the simple and elegant. His poems, which he considered merely as pastimes, contain, likewise, convincing proofs of his great genius. His prose works consist of lectures, speeches, &c.

**Buoy** (boi), any floating body employed to point out the particular situation of a ship's anchor, a shoal, the direction of a navigable channel, &c. They are made of wood, or now more commonly of wrought-iron plates riveted together and forming hollow chambers. They are generally moored by chains to the bed of the channel, &c. They are of various shapes, and receive

corresponding names; thus there are the *can-buoy*, the *nun-buoy*, the *bell-buoy*, the *mooring-buoy*, as represented in the accompanying cuts. The name is also given to a

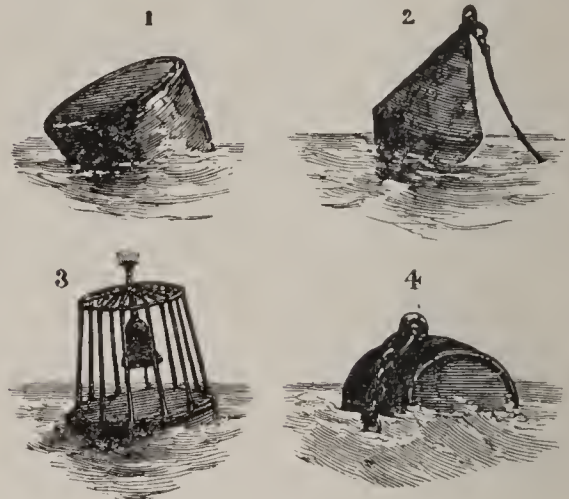

Buoys.

1, Can-buoy. 2, Nun-buoy. 3, Bell-buoy. 4, Mooring-buoy.

floating object intended to keep a person afloat till he can be taken from the water: more particularly called a life-buoy.

**Bu'phaga**, a genus of insessorial African birds, family Sturnidæ (starlings). See *Beef-eaters*.

**Bupres'tidæ**, a family of beetles, distinguished by the uncommon brilliancy and highly metallic splendour of their colours.

**Bur'bage**, RICHARD, famous actor and contemporary of Shakspeare, was the son of James Burbage (died 1597), also an actor, and the first builder of a theatre in England. He was born about 1567, died 1619. He was a member of the same company as Shakspeare, Fletcher, Hemming, Condell, and others, and filled all the greatest parts of the contemporary stage in turn. He was the original Hamlet, Lear, Othello, and Richard III., and played the leading parts in the plays of Beaumont and Fletcher, Ben Jonson, Webster, Marston, &c. Besides being an eminent actor, he seems to have been also a successful painter in oil colours.

**Bur'bot**, or BURBOLT, a fish of the cod family, genus *Lota* (*L. vulgaris*), shaped somewhat like an eel, but shorter, with a flat head. It has two small barbs on the nose and another on the chin. It is called also *Eel-pout* or *Coney-fish*, and is said to arrive at its greatest perfection in the Lake of Geneva. It is delicate food. The spotted burbot is found in American northern lakes and rivers.

**Burckhardt** (burk'hart), JOHANN LUDWIG, a noted traveller, born at Lausanne in



1784, died at Cairo 1817. He came to England in 1806, and undertook a journey of exploration to the interior of Africa for the African Association. He started in 1809, assuming an Oriental name and costume; spent some time in Syria, thence visited Egypt and Nubia; spent several months at Mecca, and visited Medina; and after a short stay in Egypt died at Cairo while preparing for his African journey. His works are: *Travels in Nubia* (1819); *Travels in Syria and the Holy Land* (1822); *Travels in Arabia* (1829); *Notes on the Bedouins and Wahabys* (1830); and *Arabic Proverbs* (1831).

**Bur'dekin**, a river of the N.E. of Queensland, with a course of about 350 miles. With its affluents it waters a large extent of country, but it is useless for navigation.

**Bur'dett**, SIR FRANCIS, English politician, born 1770, died 1844. In 1796 he entered parliament as member for Boroughbridge, and advocated parliamentary reform and various liberal measures. He afterwards sat for Middlesex and in 1807–37 for Westminster. In 1810 he was convicted of breach of privilege, and after a struggle between the police and the populace, in which some lives were lost, he was imprisoned in the Tower. In 1819 he was again imprisoned, and fined £2000 for a libel. In his later years he became a Tory, and represented North Wilts. In 1793 he married the youngest daughter of Thomas Coutts the banker.

**Burdett-Coutts** (kōts), ANGELA GEORGINA, daughter of the above, born 1814, has become deservedly popular for the liberal use she has made of the immense wealth she inherited from her grandfather (Thomas Coutts) in public and private charities. In 1871 she received a peerage from government, and in 1881 married a Mr. Ashmead-Bartlett who has assumed the name of Burdett-Coutts.

**Bur'dock**, the popular name of the composite plant *Arctium Lappa*, a coarse-looking weed with globose flower-heads, the scales of the involucre each furnished with a hook. In Britain burdocks are regarded as troublesome weeds, but in some countries the roots, young shoots, and young leaves are used in soups, and the plant is cultivated with this view in Japan. It is common in N. America.

**Burdwan'**. See *Bardwan*.

**Bureau** (bū-rō'), a writing-table; also the chamber of an officer of government and the body of subordinate officers who labour

under the direction of a chief.—*Bureau system*, or *bureaucracy*, is a term often applied to those governments in which the business of administration is carried on in departments, each under the control of a chief; or more broadly, the system of centralizing the administration of a country through regularly graded series of government officials.

**Buren**, MARTIN VAN, eighth president of the United States, born at Kinderhook, N.Y., Dec. 5, 1782. The term of his presidency was 1837–41. He died July 24, 1862.

**Burette** (bū-ret'), a graduated glass tube occasionally used for dividing a given portion of any liquid into small quantities of a definite amount.

**Burg**, a town, Prussia, province of Saxony, 12 miles N.E. of Magdeburg. It has cloth manufactures, spinning-mills, iron-foundries, &c. Pop. 15,864.

**Bur'gage Tenure**, in England, a tenure in socage, whereby burgesses, citizens, or townsmen hold their lands or tenements of the king or other lord for a certain yearly rent. In Scotland the term indicates that tenure by which the property in royal burghs is held under the crown, proprietors being liable to the (nominal) service of watching and warding, or, as it is commonly termed, 'service of burgh, used and wont.'

**Burgas** (bur'gäs), or BOURGAS, a town on the Black Sea, in East Roumelia. Pop. 5000.

**Bürger** (bür'gër), GOTTFRIED AUGUST, a celebrated German poet, born Jan. 1, 1748. He studied at Halle and Göttingen; and his attention being drawn towards literature, especially the ballad literature of England and Scotland, he was inspired with the idea of winning a reputation in this department where Uhland and Schiller had already preceded him. In 1773 appeared his *Lenore*, which took the German public by storm, and his poems have continued to be very popular with his countrymen. Scott translated his *William and Helen* and the *Wild Huntsman*. Though he wrote odes, elegies, &c., he is more at home in ballads and simple songs than in higher poetry. His life was not a successful or a happy one. He died June 8, 1794.

**Burgess** (bur'jes), a magistrate of a borough. In Pennsylvania a burgess for a borough performs the same duties as a mayor for a city.

**Burgh** (bur'e), the Scotch term corresponding to the English 'borough,' and ap-

plied to several different kinds of town corporations. A *royal burgh* is a corporate body erected by a charter from the crown. The corporation consists of the magistrates and burgesses of the territory erected into the burgh. The magistrates are generally a provost and bailies, dean of guild, treasurer, and common council. With regard to the method of electing councils, the old constitutions of the burghs exhibited an almost endless variety in their details, but all of them agreed in the essential principle of the 'close system,' by which the old councils had the privilege of electing their successors. An act in the reign of William IV. abolished this system and substituted for it a popular mode of election, and now the municipal and parliamentary franchise have been assimilated. The royal burghs now number sixty-six, most of them singly or in groups electing parliamentary representatives, though others have lost this privilege.—*Burghs of Barony* are corporations analogous to royal burghs, the magistrates of which are elected either by the superior of the barony, or by the inhabitants themselves, according to the terms of the charter of erection.—*Burghs of Regality* were a kind of burghs of barony which had regal or exclusive jurisdiction within their own territory till the abolition of hereditary jurisdictions.—*Parliamentary Burghs* are such as, not being royal burghs, send representatives to parliament. There are fifteen of these, namely, Airdrie, Cromarty, Falkirk, Galashiels, Greenock, Hamilton, Hawick, Kilmarnock, Leith, Musselburgh, Oban, Paisley, Peterhead, Port-Glasgow, and Portobello. The mode of election of councillors and magistrates of parliamentary burghs is the same as in royal burghs.—*Police Burghs* are populous places, the boundaries of which are settled in terms of the Police Act of 1862, and the affairs of which are managed by commissioners elected under the act by the inhabitants.

**Burgh Acres**, small patches of land lying in the neighbourhood of royal burghs in Scotland, usually feued out to and occupied by persons resident within the burgh.

**Burghers** (*bur'gèrz*), a body of Presbyterians in Scotland, constituting the majority of the early Secession Church, which was split into two in 1747 on the lawfulness of accepting the oath then required to be taken by the burgesses in certain burghs. The Burghers accepted the oath, while the Antiburghers did not deem it lawful.

**Burghley, BURLEIGH.** See *Cecil*.

**Burgkmair** (*burk'mir*), a family of German artists in the 15th and 16th centuries, the best known of whom is Hans, born at Augsburg in 1472. Several of his paintings are to be seen at Augsburg, Munich, Nürnberg, &c., but these have contributed far less to his fame than his woodcuts, which are not inferior to those of his friend Albert Dürer. The most celebrated is the series of 135 cuts representing the Triumph of the Emperor Maximilian. He is supposed to have died in 1559.

**Burg'lary** (derived from the French *bourg*, a town, and old French *laire*, *L. latro*, a thief) is defined in law to be a breaking and entering the dwelling-house of another, in the night, with intent to commit some felony within the same, whether such felonious intent be executed or not. Both breaking and entering are considered necessary to constitute the offence. The opening a door or window, picking a lock, &c., constitutes a *breaking*. Likewise, knocking at the door, and, on its being opened, rushing in, has been so considered. So, if a lodger in the same house open and enter another's room. The breaking and entering must, however, be in the night to make it burglary, and the duration of night is from 9 o'clock p.m. to 6 o'clock a.m. By recent statutes burglary is made punishable by penal servitude for life, or for any period not less than three years, or by imprisonment. Similar laws are prevalent in the U. States and elsewhere.

**Bürglen** (*bür'glen*), a village in the canton of Uri, Switzerland, celebrated as the birthplace of William Tell.

**Bur'gomaster**, the chief magistrate of a municipal town in the Netherlands and Germany. The title is equivalent to our *mayor* and the Scotch *provost*.

**Burgos** (*bur'gos*), a city of Northern Spain, once the capital of the kingdom of Old Castile, and now the chief town of the province of Burgos. It stands on the declivity of a hill on the right bank of the Arlanzon, and has dark narrow streets full of ancient architecture, but there are also fine promenades in the modern style. The cathedral, commenced in 1221, is one of the finest examples of Gothic architecture in Spain. It contains the tombs of the famous Cid, and of Don Fernando, both natives of Burgos, and celebrated throughout Spain for their heroic achievements in the wars with the Moors. Before the removal of the court to

## BURGOYNE — BURGUNDY.

Madrid, in the 16th century, Burgos was in a very flourishing condition, and contained thrice its present population. It has some manufactures in woollens and linens. Pop. 29,683.—The province has an area of 5650 sq. miles, largely hilly or mountainous, but with good agricultural and pastoral land. Pop. 348,152.

**Burgoyne** (bur-goin'), JOHN, an English general officer and dramatist; born 1722, died 1792. After serving in various parts of the world, he was in 1777 appointed commander

of an army against the revolted Americans, and took Ticonderoga, but had at last to surrender with his whole army at Saratoga to a greatly superior American force. He was ill received on his return to England, and deprived of his command of the 76th Light Dragoons and the governorship of Fort William, but Fox and Sheridan took his part and received his parliamentary support. Latterly he occupied himself mainly with the writing of comedies, including *The Maid of the Oaks*, *Bon Ton*,



The Cathedral of Burgos.

and *The Heiress*, a play that still holds the stage.

**Burgoyne**, SIR JOHN FOX, son of the above, an eminent officer of engineers, was born 1782. Entering the Royal Engineers he served in Malta, Sicily, Egypt, and, with Sir John Moore and Wellington, in the Peninsula from 1809 to 1814, and was present at all the sieges generally as first or second in command of the engineers. In 1851 he was made a lieutenant-general, and was chief of the engineering department at Sebastopol till recalled in 1855. In the following year he was created a baronet, and in 1868 a field-marshal. He died 7th Oct. 1871.

**Burgundy**, a region of Western Europe, so named from the Burgundians, a Teutonic or Germanic people originally from the country between the Oder and the Vistula. They migrated first to the region of the Upper Rhine, and in the beginning of the 5th century passed into Gaul and obtained possession of the south-eastern part of this country, where

they founded a kingdom having its seat of government sometimes at Lyons, and sometimes at Geneva. They were at last wholly subdued by the Franks. In 879 Boson, Count of Autun, succeeded in establishing the royal dignity again in part of this kingdom. He styled himself King of Provence, and had his residence at Arles. His son Louis added the country beyond the Jura, and thus established *Cis-Juran Burgundy*. A second kingdom arose when Rudolph of Stretlingen formed *Upper* or *Transjuran Burgundy* out of part of Switzerland and Savoy. Both these Burgundian kingdoms were united, and finally, on the extinction of Rudolph's line, were incorporated with Germany. But a third state, the historical DUCHY OF BURGUNDY, consisting principally of the French province of Bourgogne or Burgundy, had been formed as a great feudal and almost independent province of France in the 9th century. This first ducal line died out with a Duke Philip, and the duchy, reverting to the crown, was,

in 1363, granted by King John of France to his son Philip the Bold, who thus became the founder of a new line of dukes of Burgundy. A marriage with Margaret, daughter of Louis III., count of Flanders, brought him Flanders, Mechlin, Antwerp, and Franche-Comté. He was succeeded by his son Duke John the Fearless, whose son and successor, Philip the Good, so greatly extended his dominions, that on his death in 1467 his son Charles, surnamed the Bold, though possessing only the title of duke, was in reality one of the richest and most powerful sovereigns of Europe. (See *Charles the Bold*.) Charles left a daughter, Mary of Burgundy, the sole heiress of his states, who by her marriage to Maximilian of Austria transferred a large part of her dominions to that prince, while Louis XI. of France acquired Burgundy proper as a male fief of France. Burgundy then formed a province, and is now represented by the four departments of Yonne, Côte-d'Or, Saône-et-Loire, and Ain. It is watered by a number of navigable rivers, and is one of the most productive provinces in France, especially of wines. See *Burgundy Wines*.

**Burgundy Pitch**, a resin got from the Norway spruce (*Abies excelsa*) and several other pines. It is used in medicine as a stimulating plaster. It takes its name from Burgundy in France, where it was first prepared.

**Burgundy Wines** are produced in the former province of Burgundy, especially in the department of Côte-d'Or, and in richness of flavour and all the more delicate qualities of the juice of the grape they are inferior to none in the world. Amongst the red wines of Burgundy the finest are the Chambertin, the Clos Vougeot, Romanée-Conty, &c.

**Burhampur.** See *Berhampur*.

**Burhánpur**, a town of India, Central Provinces, formerly the capital of Kandeish, and famous for its muslin and flowered silk manufactures, which still exist to some extent though the town has long been declining. Pop. 30,017.

**Burial** (be'ri-al), the mode of disposing of the dead, a practice which varies amongst different peoples. Amongst savage races, and even amongst some cultured peoples of the East, exposure to wild animals or birds of prey is not uncommon. The careful embalmment of their dead by the ancient Egyptians may be regarded as a special form of burial. But by far the most common forms

of disposing of the dead have been burning and interring. Amongst the Greeks and Romans both forms were practised, though amongst the latter burning became common only in the later times of the republic. In this form of burial the corpse, after being borne in procession through the streets, was placed upon a pyre built of wood, and profusely sprinkled with oils and perfumes. Fire was set to the wood, and after the process of cremation was complete the bones and ashes were carefully gathered together by the relatives and placed in an urn. With the introduction of the Christian religion, consecrated places were appropriated for the purpose of general burial, and the Roman custom of providing the sepulchre with a stone and inscription was continued by the Christians. The practice of cremation now declined and finally disappeared, but has recently to some little extent been revived. In England every person has a right to be buried in the churchyard of the parish where he dies, and by the Burial Laws Amendment Act, 1880, it is provided that after forty-eight hours' notice to the incumbent or his substitute, such burial may take place either with the service of any Christian church or without any service.

**Bu'riats**, a nomadic Tartar people allied to the Kalmucks, inhabiting the southern part of the government of Irkutsk and Transbaikalia. Their number is about 200,000. They live in huts called *yurts*, which in summer are covered with leather, in winter with felt. They support themselves by their flocks, by hunting, and the mechanical arts, particularly the forging of iron.

**Buridan** (bù-rē-dān), JEAN, a French scholastic philosopher of the 14th century. He was a disciple of Occam at Paris, and has attained a kind of fame from an illustration he is said to have used in favour of his theory of determinism (that is, the doctrine that every act of volition is determined by some motive external to the will itself), and which still goes under the name of 'Buridan's ass.' He is said to have supposed the case of a hungry ass placed at an equal distance from two equally attractive bundles of hay, and to have asserted that in the supposed case the ass must inevitably have perished from hunger, there being nothing to determine him to prefer the one bundle to the other. The nature of the illustration, however, makes it more likely that it was invented by Buridan's opponents

to ridicule his views than by himself. Buridan died after 1358 at the age of sixty.

**Bu'rin**, or GRAVER, an instrument of tempered steel, used for engraving on copper, steel, &c. It is of a prismatic form, having



Burin.

one end attached to a short wooden handle, and the other ground off obliquely, so as to produce a sharp triangular point. In working, the burin is held in the palm of the hand, and pushed forward so as to cut a portion of the metal.

**Buriti** (bu-rē'tē), a South American palm (*Mauritia vinifera*) growing to the height of 100–150 feet, preferring marshy situations, and bearing an imposing crown of fan-shaped leaves. A sweet vinous liquor is prepared from the juice of the stem as also from the fruits.

**Burke**, EDMUND, a writer, orator, and statesman of great eminence, was born in Dublin, Jan. 1, 1730. After studying at Trinity College, Dublin, where he took a bachelor's degree, he went to London in 1750, and became a law student at the Temple. He applied himself more to literature than to law, and in 1756 published his *Essay on the Sublime and the Beautiful*, which attracted considerable attention, and procured him the friendship of some of the most notable men of the time. The political career for which he had been arduously preparing himself all along at length opened up to him on his appointment as private secretary to Mr. W. G. Hamilton, Secretary for Ireland, in 1761. On his return he was rewarded with a pension of £300 per annum, and obtained the appointment of private secretary to the Marquis of Rockingham, then First Lord of the Treasury. Through the same interest he entered parliament as member for Wendover (1765). The great question of the right of taxing the American colonies was then occupying parliament, and the Rockingham ministry having taken, mainly through Burke's advice, a middle and undecided course, was soon dissolved (1766). From 1770 to 1782 Lord North was in power, and Burke held no office. In 1774–80 he was member for Bristol. In several magnificent speeches he criticised the ministerial measures with regard to the colonies, and advocated a policy of justice and conciliation. In 1782, when the Rock-

ingham party returned to power, Burke obtained the lucrative post of paymaster-general of the forces, and shortly after introduced his famous bill for economical reform, which passed after considerable modifications had been made on it. On the fall of the Duke of Portland's coalition ministry, 1783, of which Burke had also been part, Pitt again succeeded to power, and it was during this administration that the impeachment of Hastings, in which Burke was the prime mover, took place. The lucidity, eloquence, and mastery of detail which Burke showed on this occasion have never been surpassed. The chief feature in the latter part of Burke's life was his resolute struggle against the ideas and doctrines of the French revolution. His attitude on this question separated him from his old friend Fox, and the Liberals who followed Fox. His famous



Edmund Burke.

*Reflections on the Revolution in France*, a pamphlet which appeared in 1790, had an unprecedented sale, and gave enormous impetus to the reaction which had commenced in England. From this time most of his writings are powerful pleadings on the same side. We may mention *An Appeal from the New to the Old Whigs*; *Letter to a Noble Lord*; *Letters on a Regicide Peace*; &c. In 1794 he withdrew from parliament. Three years after, on July 8, 1797, he died, his end being hastened by grief for the loss of his only son.

**Burke**, ROBERT O'HARA, an Australian explorer, born in county Galway, Ireland, in 1821, died in Australia 1861. After serving in the Austrian army he went to

Australia, and after seven years' service as inspector of police was appointed commander of an expedition to cross the continent of Australia from south to north. He and his associate Wills reached the tidal waters of the Flinders river, but both perished of starvation on the return journey.

**Burking**, a species of murder by suffocation, which derives its name from William Burke, a native of Ireland, who, in 1828-29, was detected, tried, and executed at Edinburgh, for the murder of numerous individuals. The vigilance with which the burying-grounds throughout the country were watched rendered a supply of subjects for anatomical schools almost altogether impracticable, and the demand for dead bodies consequently became great. This led the above-mentioned individual, in conjunction with another wretch named Hare, to decoy into their lodging-house and murder by strangulation many obscure wayfarers, whose bodies they sold to a school of anatomy at prices averaging from £8 to £14.

**Burleigh**, LORD. See *Cecil*.

**Burlesque** (bur-lesk') signifies a low form of the comic, arising generally from a ludicrous mixture of things high and low. High thoughts, for instance, are clothed in low expressions, noble subjects described in a familiar manner, or *vice versa*.

**Burlet'ta**, a light, comic species of musical drama, which derives its name from the Italian *burlare*, to jest.

**Burlingame**, ANSON, minister to China, was born in New York in 1820; died in 1870. He was an early worker in the free-soil party; a leader in the American party; member of congress, 1854-61; as minister to China he negotiated important treaties, securing China's recognition of international rights of property, trade, and worship.

**Burlington**, the name of several towns in the U. States. (1) A city in Vermont, on Lake Champlain, the chief commercial centre of the state, with a considerable trade in timber; woollen, cotton, and flour mills, &c. The University of Vermont is here. Pop. 14,590. (2) A city in Iowa, on the Mississippi, with a Baptist college, and manufactures of agricultural implements, &c. Pop. 22,565. (3) A city of New Jersey, on the Delaware, 7 miles above Philadelphia. Pop. 7264.

**Bur'mah**, a country of Southern Asia, bounded on the north by Assam and Thibet, on the east by Chinese territory and Siam, elsewhere mainly by the Bay of Bengal;

area about 171,400 square miles. It is traversed by great mountain ranges branching off from those of Northern India and running parallel to each other southwards to the sea. Between these ranges and in the plains or valleys here situated the four great rivers of Burmah—the Irrawaddy, its tributary the Kyen-dwen, the Sittang, and the Salwen—flow in a southerly direction to the sea, watering the rich alluvial tracts of Lower Burmah, and having at their mouths all the great seaports of the country—Rangoon, Bassein, Moulmein, Akyab, &c. The Irrawaddy is of great value as a highway of communication and traffic, being navigable beyond Bhamo, near the Chinese frontier, or over 800 miles. In their lower courses the rivers often overflow their banks in the rainy season. Though its resources are almost entirely undeveloped, the country, as a whole, is productive, especially in the lower portions. Here grow rice, sugar-cane, tobacco, cotton, indigo, &c. Cotton is grown almost everywhere; tea is cultivated in many of the more elevated parts. The forests produce timber of many sorts, including teak, which grows most luxuriantly, and is largely exported. Iron-wood is another valuable timber; and among forest products are also the bamboo, catch, stick-lac, and rubber. Burmah has great mineral wealth—gold, silver, precious stones, iron, marble, lead, tin, coal, petroleum, &c.; but these resources have not yet been much developed. The chief precious stone is the ruby, and the mines of this gem belong to the crown. Sapphire, amber, and jade are also obtained. Among wild animals are the elephant, rhinoceros, tiger, leopard, deer of various kinds, and the wild hog. Among domestic animals are the ox, buffalo, horse, and elephant. The rivers abound with fish. The most common fruits are the guava, custard-apple, tamarind, pine, orange, banana, jack, and mango. The yam and sweet-potato are cultivated, and in some parts the common potato. The climate of course varies according to elevation and other circumstances, but as a whole is warm, though not unhealthy, except in low jungly districts. The rainfall among the mountains reaches as high as 190 inches per annum.

The population, by census of Feb. 26, 1891, was stated as 7,605,560, made up of a great variety of races besides the Burmese proper, as Talangs, Shans, Karens, &c. The Burmese proper are of a brown colour, with lank, black hair (seldom any on the face),

and have active, vigorous, well-proportioned frames. They are a cheerful, lively people, fond of amusement, averse to continuous exertion, free from prejudice of caste or creed, temperate and hardy. The predominant religion is Buddhism. Missionaries are active in their efforts, but the Christian faith has not yet made much progress in the country. Polygamy is permitted by Buddhist law, but is rare, and is considered as not altogether respectable. Divorce is easily obtained. Women in Burmah occupy a much freer and happier position than they do in Indian social life. They go about freely, manage the household, and make successful women of business, conducting not merely retail trades but also large wholesale concerns. Education is very general, one of the chief occupations of the monks in the numerous monasteries being the teaching of boys to read and write. Many of these monastic schools are under government inspection. The Burmese are skilful weavers, smiths, sculptors, workers in gold and silver, joiners, &c. The ordinary buildings are of a very slight construction, chiefly of timber or bamboo raised on posts; but the religious edifices are in many cases imposing, though the material is but brick. Carving and gilding are features of their architecture. The Burmese language is monosyllabic, like Chinese, and is written with an alphabet the characters of which (derived from India) are more or less circular. There is a considerable literature.

Burmah is now divided into *Lower Burmah* and *Upper Burmah*, the former till 1886 being called British Burmah, while the latter till that date was an independent kingdom or empire. Lower Burmah was acquired from Independent Burmah in 1826 and 1852 as the result of two wars terminating in favour of Britain. It comprises the divisions of Aracan, Pegu, Irrawaddy, and Tenasserim; area, 87,473 sq. miles; pop. (1891), 2,946,933. Under British rule it has prospered greatly, the population and trade having increased immensely, there being regularly a large surplus revenue. Roads, canals, and railways have been constructed and other public works carried out, as also public buildings erected. The total foreign trade is valued at over £10,000,000; the exports to Britain in 1891 amounted to £2,403,268 (chiefly rice); imports from Britain £2,134,850. The chief city and port is Rangoon, which is now connected by railway with Mandalay in Upper Burmah.

Under its native kings the form of government in Upper Burmah was absolute monarchy, the seat of government being latterly at Mandalay. The king was assisted in governing by a council of state known as the *Hloot-daw*, to which belonged the functions of a house of legislature, a cabinet, and a supreme court. The king had power to punish at his pleasure anyone, even the great officers of state. The revenue was derived from taxes levied in a very irregular and capricious manner, and official corruption was rampant. The criminal laws were barbarously severe. Capital punishment was commonly inflicted by decapitation, but crucifixion and disembowelling were also practised. After the loss of the maritime provinces the influence of Independent Burmah greatly declined, as did also its Asiatic and foreign trade.

The Burmese empire is of little note in ancient or general history. Since the 16th century the Burmese proper have mostly been the predominant race, and ruled the Peguans, Karens, &c., throughout the country. The capital has at different times been at Ava, Pegu, Prome, or elsewhere. In the latter half of the 18th century the Burmese emperors began a series of wars of conquest with China, Siam, Assam, through which they greatly enlarged the empire. This brought them into contact with the British, and in 1824 war was declared against them on account of their encroachments on British territory and their seizure of British subjects. The war terminated in the cession of the provinces of Aracan and Tenasserim to the British. Peace continued for some years, but latterly various acts of hostility were committed by the Burmese, and in 1852 the maltreatment of British subjects occasioned a second war, at the end of which the British possessions were extended to include the whole of Pegu. The third and last war occurred in 1885 in consequence of the arrogance and arbitrary conduct of King Theebaw. The result was that Upper Burmah was annexed to the British empire by proclamation of the Viceroy of India, 1st Jan. 1886. The area thus annexed was about 200,000 sq. miles, of which half belonged to the kingdom proper, half to the semi-independent Shan states. Its government is not yet fully organized, but it has been put under a chief-commissioner and divided into provinces (under commissioners), which again are subdivided into districts. The Shan states are

to be governed by their own chiefs through British political officers. The country is yet far from tranquil, bands of *dacoits* or robbers causing much trouble. There are about 20,000 military stationed in it.

**Bur'naby**, FREDERICK GUSTAVUS, English soldier and traveller, born 1842, son of the Rev. G. Burnaby. He was educated at Harrow, and entered the Royal Horse Guards in his eighteenth year. In 1875 he made his famous ride to Khiva—a journey that presented great difficulties. In 1876 he rode through Asiatic Turkey and Persia. Of both these journeys he published narratives. In 1885 (Jan. 17), while serving as lieutenant-colonel of the Royal Horse Guards in the Egyptian campaign, he was slain at the battle of Abu-Klea.

**Burne-Jones**, EDWARD, an English painter, born in 1833, at Birmingham, where and at Exeter College, Oxford, he was educated. He early adopted the profession of artist, and came under the influence of D. G. Rossetti. He has painted in water-colour as well as oil, and his works are remarkable for richness of colouring as well as for their poetical, ideal, and mediæval characteristics.

**Burnes** (bérnz), SIR ALEXANDER, was born at Montrose in 1805, studied at the academy there, and having obtained a cadetship in the Indian army arrived at Bombay in 1821. His promotion was rapid, and in 1832 he was sent on a mission to Central Asia, and visited Afghanistan, Bokhara, Merv, &c., returning by way of Persia. He was then sent to England, and published his travels, which were read with a kind of enthusiasm. In 1839 he was appointed political agent at Cabul. Here, in 1841, he was murdered on the breaking out of an insurrection, as, thirty-eight years later, Sir Louis Cavagnari, with his staff, was murdered.

**Bur'net**, the popular name of two genera of plants, natural order Rosaceæ:—1. COMMON or LESSER BURNET (*Poterium Sanguisorba*), a perennial plant of Europe and N. America which grows to the height of about 2 feet, with smooth, alternate, imparipinnate leaves, and flowers arranged in rounded heads of a purplish colour. — 2. GREATER BURNET (*Sanguisorba officinālis*), also a perennial plant with imparipinnate leaves; flowers red, arranged on oval spikes at the extremity of long peduncles. Both kinds make very wholesome food for cattle. *S. canadensis* is a Canadian species.

**Bur'net**, GILBERT, a celebrated prelate and historian, born at Edinburgh in 1643. Having

studied at Aberdeen, he travelled into Holland in 1664. He was ordained in 1665, was for some years minister of Saltoun parish, and became professor of divinity at Glasgow in 1669. Here he resided more than four years and wrote several works, one of them his Vindication of the Church and State of Scotland. In 1675 he became chaplain to the Rolls Chapel, London. He was long in great favour at court, but the court favour did not continue, for Burnet, dreading the machinations of the Catholic party, joined the opposition, and wrote his History of the Reformation in England, the first volume of which appeared in 1679 (the other two in 1681 and 1714 respectively). His connection with the opposition party afterwards became very intimate, and he published several works in favour of liberty and Protestantism. Eventually he was invited to the Hague by the Prince and Princess of Orange, and had a great share in the councils relative to Britain. He accompanied the Prince of Orange to England as chaplain, and was rewarded for his services with the bishopric of Salisbury. As a prelate Bishop Burnet distinguished himself by fervour, assiduity, and charity. He died in March 1715, leaving behind him his well-known History of his Own Times (two vols. fol. 1723–24).

**Bur'nett**, JAMES, Lord Monboddo, judge of the Court of Session in Scotland, born in 1714 at the family seat of Monboddo, in Kincardineshire. After studying at Aberdeen he went to the University of Groningen, whence he returned in 1738, and commenced practice as an advocate at the Scottish bar. In 1767 he was made one of the lords of session. He distinguished himself by his writings as a metaphysician, having published a Dissertation on the Origin and Progress of Language (1771–76, three vols. 4to), and Ancient Metaphysics (1778, &c., three vols. 4to). His works contain a strange mixture of paradox and acute observation. He died at Edinburgh May 26, 1799.

**Burnett Prizes**, prizes established by a Mr. Burnett, merchant of Aberdeen, on his death in 1784. He left a fund from which were to be given every forty years two theological prizes (not less than £1200 and £400) for the best two essays in favour of the evidence that there is an all-powerful, wise, and good Being, and this independent of all revelation. The first competition was in 1815, when Dr. Brown, principal of Aberdeen University, gained the first prize, and



Dr. John Bird Sumner, afterwards Archbishop of Canterbury, the second. In 1855 the first prize was adjudged to the Rev. R. A. Thompson, Lincolnshire, and the second prize to the Rev. Dr. John Tulloch, afterwards principal of St. Mary's College, St. Andrews. The destination of the fund has latterly been altered by parliament, and courses of lectures are now delivered, the first, on light, being by Prof. Gabriel Stokes in 1883.

**Burnett's Disinfecting Liquid**, an anti-septic liquid and deodorizer prepared from chloride of zinc. It is useful in deodorizing sewage, bilge-water in ships, &c., and is found of service in the dissecting-room.

**Burney**, CHARLES, an English composer and writer on music, born 1726, died 1814. He studied under Dr. Arne, and soon obtained a reputation for his musical pieces. While organist at Lynn Regis he commenced his *General History of Music*. He wrote also several other valuable works. His second daughter, Frances Burney (*Madame d'Arblay*), published a memoir of her father.

**Burning-glass**, a lens which, by bringing the sun's rays rapidly to a focus, produces a heat strong enough to kindle combustible matter. The lenses commonly used are convex on both sides, and having a small focal distance. That such a glass may produce its greatest effect it is necessary that the rays of the sun should fall upon it in a perpendicular direction. The effect may be greatly augmented by the use of a second lens, of a smaller focal distance, placed between the first and its focus. Some immense burning-glasses have been made, producing surprising effects. *Concave burning-mirrors* produce the same kind of results, and have almost four times more power than burning-glasses of equal extent and curvature. The concavity must present a surface of high reflecting power (polished silver or other metal, or silvered glass), and must be either spherical or parabolic. Plane mirrors may also be employed like concave ones, if several of them are combined in a proper manner. The ancients were acquainted with such mirrors, and Archimedes is said to have set the Roman fleet on fire at the siege of Syracuse (B.C. 212) by some such means. In 1747 Buffon by a combination of mirrors burned wood at the distance of 200 feet and melted tin at the distance of 150, &c.

**Burning-mirrors.** See preceding article.

**Burnisher**, a blunt, smooth tool, used for smoothing and polishing a rough surface by rubbing. Agates, tempered steel, and dogs' teeth are used for burnishing.

**Burn'ley**, a parliamentary and municipal borough of England, in Lancashire, about 22 miles N. of Manchester. The town presents a modern appearance, and is, generally speaking, well built, mostly of stone. The staple manufacture is cotton goods, and there are large cotton-mills and several extensive foundries and machine-shops, with collieries and other works, in the vicinity. Burnley was made a parliamentary borough with one member in 1867. Pop. 87,058.

**Burnoose** (*bër-nös'*), a large kind of mantle in use among the Bedawin Arabs and the Berbers of Northern Africa, commonly made of white wool, but sometimes also of red, blue, green, or some other colour, and having a hood which may be drawn over the head in case of rain.

**Burnouf** (*bür-nöf*), EUGÈNE, French scholar, born at Paris in 1801, died 1852. He devoted himself to the study of oriental languages, particularly those of Persia and India. In 1826 he attracted the attention of men of learning throughout Europe by publishing, in conjunction with his friend Chr. Lassen, an *Essay on the Pali*, or the sacred language of the Buddhists in Ceylon and the Eastern Peninsula. But his fame is chiefly due to his having, so to speak, restored to life an entire language, the Zend or old Persian language in which the Zoroastrian writings were composed. Burnouf also distinguished himself by his labours on Buddhism, publishing *Introduction à l'Histoire du Bouddhisme Indien*.

**Burns**, ROBERT, the great lyric poet of Scotland, was born near Ayr, January 25, 1759, his father being a gardener, and latterly a small farmer. He was instructed in the ordinary branches of an English education by a teacher engaged by his father and a few neighbours; to these he afterwards added French and a little mathematics. But most of his education was got from the general reading of books, to which he gave himself with passion. In this manner he learned what the best English poets might teach him, and cultivated the instincts for poetry which had been implanted in his nature. At an early age he had to assist in the labours of the farm, and when only fifteen years old he had almost to do the work of a man. In 1781 he went to learn the business of flax-dresser at Irvine, but the

premises were destroyed by fire, and he was thus led to give up the scheme. His father dying in 1784, he took a small farm (Moss-giel) in conjunction with his younger brother Gilbert. He now began to produce poetical pieces which attracted the notice of his neighbours and gained him considerable reputation. His first lines had been written sometime previously, having been inspired by love, a passion to which he was peculiarly susceptible. While at Moss-giel he formed a connection with Jean Armour, a Mauchline girl, which resulted in the prospect of her soon becoming a mother. Burns was willing to marry her, but her father, a respectable master mason, would not permit it, deeming Burns, on account of his poor circumstances, and perhaps for other reasons, no suitable match. This affair rendered the poet's position so uncomfortable, and so wounded his pride, that he determined to emigrate to Jamaica, and engaged himself as assistant overseer on a plantation there. To obtain the funds necessary for the voyage he was induced to publish, by subscription, a volume of his poetical effusions. It was printed at Kilmarnock in 1786, and Burns, having thus obtained the assistance he expected, was about to set sail from his native land, when he was drawn to Edinburgh by a letter from Dr. Blacklock to an Ayrshire friend of his and the poet, recommending that he should take advantage of the general admiration his poems had excited, and publish a new edition of them. This advice was eagerly adopted, and the result exceeded his most sanguine expectations. After remaining more than a year in the Scottish metropolis, admired, flattered, and caressed by persons of eminence for their rank, fortune, or talents, he retired to the country with the sum of some £500, which he had realized by the second publication of his poems. A part of this sum he advanced to his brother, and with the remainder took a considerable farm (Ellisland) near Dumfries, to which he subsequently added the office of exciseman. He now married, or rather formally completed his marriage with Jean Armour. But the farming at Ellisland was not a success, and in about three years Burns removed to Dumfries and relied on his employment as an exciseman alone. He continued to exercise his pen, particularly in the composition of a number of beautiful songs adapted to old Scottish tunes. But his residence in Dumfries, and the society of the idle and the dissipated who gathered

round him there, attracted by the brilliant wit that gave its charm to their convivialities, had an evil effect on Burns, whom disappointment and misfortunes were now making somewhat reckless. In the winter of 1795 his constitution, broken by cares, irregularities, and passions, fell into premature decline; and in July, 1796, a rheumatic fever terminated his life and sufferings at the early age of thirty-seven. He left a wife and four children, for whose support his friends and admirers raised a subscription, and with the same object an edition of his works, in four vols. 8vo, was published in 1800 by Dr. Currie of Liverpool. His character, though marred by imprudence, was never contaminated by duplicity or meanness. He was an honest, proud, warm-hearted man, combining sound understanding with high passions and a vigorous and excursive imagination. He was alive to every species of emotion; and he is one of the few poets who have at once excelled in humour, in tenderness, and in sublimity.

**Burns and Scalds** are injuries produced by the application of excessive heat to the human body. They are generally dangerous in proportion to the extent of surface they cover, and a wide-spread scald may cause serious consequences on account of the nervous shock. Congestion of the brain, pneumonia, inflammation of the bowels, or lock-jaw may result from an extensive burn. Hence the treatment requires to be both local and constitutional. If there is shivering or exhaustion hot brandy and water may be given with good effect, and if there is much pain, a sedative solution of opium. The local treatment consists in dredging the burn with fine wheat flour, and then wrapping it up in cotton-wool. An application of equal quantities of olive-oil and lime-water, called carron-oil, is much recommended by some, the part being afterwards covered by cotton-wool. The main thing is to keep the air from the injured part, and therefore, when a blister forms, although it may be pricked, the loose skin should not be removed.

**Burnt'island**, a royal burgh and seaport of Scotland, in Fife, on the estuary of the Forth, a favourite summer residence and bathing-place as well as a busy port. Shale-oil, vegetable oil, and oil-cake are made, and there are railway repairing works and a distillery. Burntisland unites with Kinghorn, Dysart, and Kirkcaldy in sending a member to parliament. Pop. 4096.

**Burnt-offering**, something offered and burnt on an altar as an atonement for sin; a sacrifice. The burnt-offerings of the Jews were either some clean animal, as an ox, a sheep, a pigeon; or some species of vegetable substance, as bread, flour, ears of wheat or barley.

**Burnt-sienna**, an ochreous earth known as sienna earth (*Terra di Sienna*) submitted to the action of fire, by which it is converted into a fine orange-brown pigment, used both in oil and water-colour painting.

**Burnt-umber**, a pigment of reddish-brown colour obtained by burning umber, a soft earthy mixture of the peroxides of iron and manganese, deriving its name from Umbria in Italy.

**Buro**. See *Booro*.

**Burr, AARON**, third vice-president of the United States, born in New Jersey in 1756. After serving with honour in the Revolutionary army he became a lawyer, and finally leader of the Democratic party and vice-president 1801. His duel with Alexander Hamilton, which ended fatally for the latter, drove him from New York to settle further west, where he conceived an audacious and grandiose scheme of founding an empire in the s.w. He was tried for treason, and though acquitted, sank into obscurity. He died in 1836.

**Burrard Inlet**, an inlet of British Columbia, forming a fine harbour, and having Vancouver, the terminus of the Canadian Pacific Railway, on its northern shore.

**Burrillville**, Providence co., R. I., has numerous manufactories and national bank. Pop. 1890, 5492.

**Bur'ritt, ELIHU**, the 'learned blacksmith,' was born at New Britain, Conn., Dec. 8, 1810. He was apprenticed to a blacksmith, but began to read English literature, and acquired proficiency in the ancient and most modern languages of Europe. He afterwards came into public notice as a lecturer on behalf of temperance, the abolition of slavery and war, &c., and founded papers, missions, and organizations to further these ends. In 1848 the first International Peace Congress was held under his guidance at Brussels. In 1865 he was consular agent at Birmingham. In 1868 he returned to live on his farm in America, and died March 7, 1879. His best-known writings are *Sparks from the Anvil*; *Thoughts and Things at Home and Abroad*; *Chips from Many Blocks*; &c.

**Burrowing-owl**, an American owl, the

*Athēna cunicularia*, which dwells in holes in the ground either made by itself or by some other animal, as the prairie-dog or marmot. It feeds on insects and seeks its food by day.

**Burrstone**. See *Buhrstone*.

**Bur'sary**, an endowment in one of the Scotch universities, corresponding to an exhibition in an English university, and intended for the support of a student during his ordinary course, and before he has taken a degree in the faculty in which he holds the bursary. This circumstance, according to the usage prevailing in Scotland, distinguishes bursaries from scholarships and fellowships, both of which are bestowed after the student has taken a degree. Each of the four universities of Scotland has a greater or smaller number of bursaries. Of late years most bursaries are awarded after competitive examination, and only a few are now given by the patrons for special reasons.

**Burscheid** (bur'shīt), a manufacturing town of Prussia, some 20 miles from Düsseldorf. Pop. 6828.

**Burs'lem**, a town of England, in Staffordshire, within the parliamentary borough of Stoke-upon-Trent, and in the centre of 'The Potteries.' Here is the Wedgwood Memorial Institute, comprising a free library, a museum, and a school of art, erected in honour of Josiah Wedgwood, who was born at Burslem in 1730. Burslem has extensive manufactures of china and earthenware, in which trade and coal-mining the inhabitants are chiefly employed. Pop. 1891, 30,862.

**Burton, JOHN HILL**, historian of Scotland, born at Aberdeen 1809, died near Edinburgh 1881. He graduated at Marischal College, Aberdeen, adopted the law as a profession, and became an advocate in Edinburgh, but literature was really the business of his life. He early contributed to the *Westminster Review*, as afterwards to the *Edinburgh and North British*, to *Blackwood's Magazine*, and to the *Scotsman*. His first book was the *Life and Correspondence of David Hume* (1846), followed by *Lives of Lord Lovat and Duncan Forbes of Culloden*, and other works. His chief work was his *History of Scotland from the Earliest Times to 1746* (2d edition, 8 vols. 1873); others equally well known were *The Scot Abroad*, and *the Book-hunter*. He was appointed secretary to the Scottish Prison Board in 1854, and was connected with this department till his death.

**Burton**, SIR RICHARD FRANCIS, K.C.M.G., English traveller and linguist, born in 1821. He joined the Indian army in 1842, and showed a remarkable facility in acquiring the languages and manners of the natives. In 1853 he went to Arabia, and visited Mecca and Medina disguised as a Mohammedan pilgrim—a sufficiently dangerous journey. After serving in the Crimean war he made a journey to East Africa along with Captain Speke, which led to the discovery of the great lake Tanganyika. He has been British consul at Fernando Po, at Santos in Brazil, and from 1872 at Trieste. He has visited many countries and published many works, amongst which are *Sindh and the Races that inhabit India*; *Personal Narrative of a Pilgrimage to El Medinah and Mecca*; *The Lake Regions of Central Africa*; *The City of the Saints and across the Rocky Mountains to California*; *The Nile Basin*; *The Highlands of Brazil*; *Ultima Thule, or a Summer in Iceland*; *The Gold Mines of Midian*; *The Book of the Sword*; translations of Camoens' *Lusiads* and of the *Arabian Nights*; &c. Died 1890.

**Bur'ton**, ROBERT, an English writer, born at Lindley in Leicestershire in 1576. He studied at Christ Church, Oxford, where he seems to have lived all his life. His vast out-of-the-way learning is curiously displayed in his book *The Anatomy of Melancholy*, which he published in 1621. Burton died in 1640.

**Burton**, WM. E., a celebrated comedian, born in London, 1804, died in New York, 1860; edited *Cyclopædia of Wit and Humor*.

**Burton-on-Trent**, a municipal borough of England, in Staffordshire, on the N. bank of the Trent, in a low, level situation. Malting and iron-founding are carried on to a considerable extent, but it is chiefly celebrated for its excellent ale, for which there are numerous breweries, employing upwards of 5000 men and boys, the largest establishments being those of Messrs. Bass & Co. and Messrs. Allsopp. Pop. 1891, 46,047.

**Burtscheid** (burt'shīt), a town in Rhenish Prussia, forming a suburb of Aix-la-Chapelle, with extensive manufactures, particularly of woollens, and celebrated thermal springs. Pop. 12,139.

**Bury** (be'ri), a municipal and parliamentary borough (with one member) of England, in Lancashire, 8 miles N.N.W. of Manchester, well situated on a rising ground between the Irwell and the Roche. The staple manufacture is that of cotton, and there are

also large woolen factories, bleaching and printing works, dye-works, foundries, &c. Pop. 1891, 57,206.

**Burying-beetle** (*Necrophorus*), the name of a genus of insects belonging to the order Coleoptera, or beetles, and the tribe of the Silphidæ, or carrion beetles.

**Burying-places.** The famous Père la Chaise, in Paris, is the most celebrated of modern burying-places. It was laid out in 1804, and comprises 200 acres. The chief cemeteries of London are Kensal Green, Highgate, Abney Park, Norwood, Nunhead, West London, &c.; of the U. States, Mount Auburn near Boston, Laurel Hill in Philadelphia, Greenwood for New York and Brooklyn.

**Bury St. Edmund's**, or ST. EDMUNDS-BURY, a parliamentary and municipal borough in Suffolk, England, well built and delightfully situated on the Larke, 26 miles from Ipswich. Agricultural implements are manufactured, and there is a large trade in agricultural produce. Bury St. Edmund's sends one member to parliament. It is an ancient place, and derived its name from St. Edmund, a king of the East Angles, slain by the heathen Danes and buried here. It contains the remains of an abbey, once the most wealthy and magnificent in Britain. Pop. 1891, 16,630.

**Busa'co**, a mountain ridge in the province of Beira, Portugal. It was here that Wellington repulsed Massena (27th September, 1810) and continued his retreat to the lines of Torres Vedras.

**Busby** (buz'bi), a military head-dress worn by hussars, artillerymen, and engineers, consisting of a fur hat with a bag, of the same colour as the facings of the regiment, hanging from the top over the right side. The bag appears to be a relic of a Hungarian head-dress from which a long padded bag hung over, and was attached to the right shoulder as a defence against sword-cuts.

**Bush-buck**, a name given to several species of antelopes, especially to *Tragelaphus sylvatica*, an antelope of S. Africa, 4 feet long and 2½ feet high, with triangular sub-spiral horns. The male is dark sepia brown and the female reddish brown above; both are white below. The *white-backed bush-buck* is the *Cephalophus sylvicultrix*, a white-backed antelope of Sierra Leone, with black shining, pointed, and nearly straight horns, short slender limbs, sleek, glossy, deep-brown hair.

**Bushel**, an English dry measure, containing 8 gallons or 4 pecks. The British imperial bushel introduced in 1826 has a capacity of 2218·192 cubic inches, and holds 80 lbs. avoirdupois of distilled water at the temperature of 62° Fahr. with the barometer at 30 inches. It has been adopted in many of the United States—exceptions, New York, Connecticut, Kentucky, Indiana, Ohio, Mississippi, and Missouri.

**Bushire** (bö'shēr; properly, *Abu Shehr*, the father of cities), the principal seaport of Persia, on the Persian Gulf, 118½ miles w.s.w. Shiraz. It lies on the edge of a desert, and is a mean, unhealthy, and dirty place. It carries on a considerable traffic with India and Britain, importing rice, indigo, sugar, cotton goods, &c., and exporting shawls, dates, tobacco, carpets, wool, drugs, &c. The anchorage is indifferent, but is the best on the coast. Pop. perhaps 25,000.

**Bushmen**, or BOSJESMEN, a race of people who dwell in the western part of South Africa, in the immense plains bordering on the n. side of the colony of the Cape of Good Hope. They are the most degraded of the races who inhabit this part of the country. They do not form societies, but unite only for defence or pillage. They have no huts, and do not cultivate the land, but support themselves by hunting. Their language is exceedingly poor, consisting only of a certain clicking with the tongue and harsh gurgling tones, for which we have no letters.

**Bush-pig.** See *Bosch-vark*.

**Bush'rangers**, the name for desperadoes in Australia who, taking to the bush, have supported themselves by levying contributions on the property of all and sundry within their reach. Considerable gangs of these lawless characters have sometimes collected, a body of fifty holding part of New S. Wales in terror about 1830. A gang of four fell victims to justice in 1880, after having robbed a bank and committed other outrages.

**Bush-shrikes**, American birds of the shrike family, forming the group *Thamnophilinæ*.

**Business Colleges**, the name in America for the higher-class institutions specially intended to give a practical training in all subjects belonging to commerce.

**Busi'ris**, a town of ancient Egypt, in the Delta, the chief place where the rites of Isis were celebrated. The name is also given as that of a mythical Egyptian king.

**Bus'kin**, a kind of high shoe worn upon the stage by the ancient actors of tragedy, in order to give them a more heroic appearance: often used figuratively for tragedy, like 'sock' for comedy.

**Buss**, a small vessel from 50 to 70 tons burden, carrying two masts, and with two sheds or cabins, one at each end, used in herring-fishing.

**Buss'orah.** See *Bassora*.

**Bussu-palm**, the *Manicaria saccifera*, found in the swamps of the Amazon, whose stem is only 10 to 15 feet high, but whose leaves are often 30 feet long by 4 to 5 feet in breadth. These are used by the Indians for thatch, the spathes are used as bags, or when cut longitudinally and stretched out they form a coarse but strong kind of cloth.

**Bust** (Fr. *buste*, It. *busto*), in sculpture, the representation of that portion of the human figure which comprises the head and the upper part of the body. During the literary period of Greece the portrait busts of the learned formed an important branch of art, and in this way we come to possess faithful likenesses of Socrates, Plato, Demosthenes, &c., in which the artists show great power of expressing the character of those represented. The number of busts belonging to the time of the Roman Empire is very considerable, but those of the Roman poets and men of letters have not been preserved in nearly so large numbers as those of the Greeks. The first bust that can be depended upon as giving a correct likeness is that of Scipio Africanus the elder.

**Bus'tard**, a bird belonging to the order *Cursores*, or runners, but approaching the waders. The great bustard (*Otis tarda*) is



Great Bustard (*Otis tarda*).

the largest European bird, the male often weighing 30 lbs., with a breadth of wing of 6 or 7 feet. The bustard is now rare in Britain, but abounds in the south and east of Europe and the steppes of Tartary, feeding on green corn and other vegetables, and

on earth-worms. Its flesh is esteemed. All the species run fast, and take flight with difficulty. The little bustard (*O. Tetrax*) occasionally visits Britain. *O. nigriceps* is an Asiatic and *O. caerulea* an African species. The Australian species (*O. australianus*) is a magnificent bird highly prized as food.

**Busto-Arsizio**, a town of N. Italy, 20 miles N.W. of Milan. Pop. 9291.

**Butcher-bird.** See *Shrike*.

**Butcher's Broom** (*Ruscus*), a genus of plants belonging to the natural order Liliaceae. The flowers are dioecious and of a green colour, and rise from branchlets dilated in the form of leaves. It is a shrubby evergreen plant, with angular stems. There are several species: *Ruscus aculeatus*, or the common butcher's broom, takes its name from being used by butchers to sweep their blocks.

**Bute** (būt), an island of Scotland in the estuary of the Clyde, with an area of 30,000 acres, belonging principally to the Marquis of Bute. It is about 15 miles long, and the average breadth is  $3\frac{1}{2}$  miles. In Kames Hill it rises to the height of 875 feet; it has several pretty lakes, the principal of which is Loch Fad,  $2\frac{1}{4}$  miles long. Agriculture is in an advanced state, and there are about 20,000 acres under cultivation. The herring-fishery is also a source of considerable profit. The only town is Rothesay, whose ancient castle is one of the interesting antiquities of the island. The climate of Bute is milder than that of almost any part of Scotland. The county of Bute comprises the islands of Bute, Arran, Great Cumbrae, Little Cumbrae, Inchmarnock, and Pladda, with a total area of 143,997 acres, but only a small part is under cultivation. Arran is about double the size of Bute, but the other islands belonging to the county are small. Buteshire returns one member to parliament. Pop. 1891, 18,408.

**Bute, JOHN STUART, EARL OF**, a British statesman, born in 1713 in Scotland. He acquired great influence over Frederick, Prince of Wales, and was appointed chamberlain to his son, afterwards George III., through whose favour he became secretary of state, and ultimately, in 1762, prime-minister. For a time Pitt and Newcastle alike had to give way to his influence, but though possessing the full confidence of the king he was unpopular with the people, and in 1763 he suddenly resigned his office, and retired from public affairs to spend his lei-

sure in literary and scientific pursuits, particularly in botany. He died in 1792. The present representative of the family is John Patrick Crichton Stuart, Marquis of Bute, fourth in descent from the preceding, born Sept. 12, 1847. He is known as a writer on archæological subjects.

**Bu'tea**, a genus of plants, nat. order Leguminosae, tribe Papilionaceae, natives of the East Indies. They are trees having pinately trifoliate leaves, with racemes of deep scarlet flowers.

**Butler**, the seat of Butler Co., Pa., 30 miles N. of Pittsburgh; centre of gas, oil, coal and iron industries. Pop. 1890, 8734.

**Butler, ALBAN**, English Roman Catholic writer, born 1711, died 1773. He was educated at the English (R.C.) College, Douay, where he became professor first of philosophy and then of divinity; latterly he was president of the English college St. Omer. His Lives of the Saints is a monument of erudition which cost him thirty years' labour.

**Butler, BENJAMIN FRANKLIN**, an American lawyer, general, and politician, born at Deerfield, N.H., Nov. 5, 1818. He became noted as a criminal lawyer; in 1853 commenced to take a prominent part in politics on the Democratic side: in 1861, on the outbreak of the war, held the commission of brigadier-general of militia, and took service with his brigade on the Union side. During that eventful struggle he remained in high command, winning laurels for energy and ability in regard to other than military manœuvres. In 1866 he was elected member of congress for Massachusetts and was re-elected to that body in 1868. As a law practitioner he had few equals. In 1882 General Butler was elected governor of Massachusetts. He died Jan. 11, 1893.

**Butler, JAMES**, Duke of Ormonde, an eminent statesman in the reigns of Charles I. and II. He was born at London in 1610, was a steady adherent of the royal cause, on the ruin of which he retired to France. At the Restoration he returned with the king, was created a duke, and appointed lord-lieutenant of Ireland. After losing his office and the royal favour for some years, principally through the intrigues of Buckingham, he was again appointed lord-lieutenant of Ireland, and retained the post till the death of Charles, when he resigned, his principles not suiting the policy of James. He died in 1688.

**Butler, JOSEPH**, an English prelate and celebrated writer on ethics and theology

born in Berkshire in 1692. He was brought up a dissenter, but after examining the points of controversy between the Established Church and the dissenters, he decided to become a member of the former, and accordingly removed to Oxford in 1714, where he took orders. The sermons which he delivered as preacher at the Rolls Chapel, an appointment he occupied in 1718–26, still hold a high place in ethical literature. But his great work is the *Analogy of Religion, Natural and Revealed, to the Constitution and Course of Nature*, which was published in 1736, and acquired for him a great reputation. In 1738 he was made Bishop of Bristol, and in 1750 promoted to the see of Durham. He died in 1752.

**Butler, SAMUEL**, English satirical poet, was the son of a farmer in Worcestershire, where he was born in 1612. He was educated at Worcester free-school, and held



Samuel Butler.

various situations as clerk or amanuensis to persons of position, among them being Sir Samuel Luke, a Puritan colonel of Bedfordshire, who is caricatured in the celebrated knight *Hudibras*. Butler published the first part of *Hudibras* after the Restoration, in 1663. It became immensely popular, and Charles II. himself was perpetually quoting the poem, but did nothing for the author, who seems to have passed the latter part of his life dependent on the support of friends, and died in poverty in London in 1680. A second part of *Hudibras* appeared in 1664, a third in 1673. The poem is a sort of burlesque epic ridiculing Puritanism, and fanaticism and hypocrisy generally.

**Butte City**, the seat of Silver Bow county, Montana, one of the richest mining centres, 2 banks, 2 newspapers. Pop. 1890, 10,723.

**Bu'tomus.** See *Flowering-rush*.

**Butter**, a fatty substance produced from milk, especially cows' milk. When the milk is first drawn this fatty matter is disseminated through it in minute clear globules inclosed in membranous sacs or bags which in a short time rise to the surface and form cream. The cream is then skimmed off to undergo the operation of churning, which by rupturing the sacs effects a separation of the cream into a solid called *butter* and a liquid called *butter-milk*, the latter consisting of whey and other caseous matter. In some cases, however, in order to save time, the churning is done before the cream has separated from the milk, and machines for hastening the process of separation are occasionally used. The quality of the butter depends much upon the treatment of the cream at this stage. Its temperature in warm weather ought to be between 53° and 55°; in colder weather several degrees higher. If too cold the fat is hard and does not coalesce, and if too warm it becomes semi-liquid. The butter, being formed into lumps, is washed well in cold water, and kneaded till all the butter-milk has been expelled. Butter of good quality has a faint sweet odour and a soft delicate flavour. Its composition varies somewhat according to the way in which it is made. It has usually from 80 to 90 per cent of pure fat, the rest consisting of casein, water, and salt. The water should not amount to more than 10 per cent, nor the salt to more than 2 per cent of the whole weight, but butter is frequently adulterated by the excess of these two elements. Where the butter is to be preserved only for a short time, keeping it in a cool place and covering it with pure water daily will perhaps be sufficient. More certain methods are to use water mixed slightly with tartaric acid or vinegar, or to salt it lightly, thus making what is known as 'powdered' butter. Butter which is to be thoroughly 'cured,' so as to keep for some length of time, is usually prepared with from 5 to 8 per cent of common salt. In preserving butter it is important to exclude the air as much as possible. When exported to warm climates it may be packed in 1-lb. or 2-lb. bottles, with mouths about 2 in. across, and fitted with glass stoppers and cemented so as to be air-tight. Or hermetically sealed tins may be used.

The United Kingdom, Holland, the north-western districts of France, Russia, Denmark, Sweden, Belgium, the United States and Canada, are large producers of butter. Large quantities are imported into Great Britain from Ireland, the U. States and Canada, Denmark, &c. Butter factories are now common—large establishments which receive the milk produced at many neighbouring farms. In the warmer countries olive or other oil is more used than butter. The butter, beer, and animal food of the n. of Europe give way to oil, wine, and bread in the southern regions.—The name of *mineral butters* was given by the old chemists to certain substances which are of the consistence of butter when recently prepared. *Vegetable butters* are fixed vegetable oils which are solid at common temperatures, such as palm-oil, cocoa-nut oil, shea, nutmeg-oil, &c. See also *Butterine*.

**Butter-bur** (*Petasites vulgāris*), a composite plant, with large rhubarb-like leaves and purplish flowers, growing by the side of streams; allied to colt's-foot.

**Buttercup**, the popular name of two or three species of the *Ranunculus*, namely, *R. acris*, *R. bulbōsus*, and *R. repens*. They are common plants with brilliant yellow flowers.

**Butterfly**, the common name of all diurnal lepidopterous insects, corresponding to the original Linnæan genus *Papilio*. The family of the butterflies or diurnal *Lepidoptera* (so called to distinguish them from nocturnal or crepuscular *Lepidoptera*, such as moths) is a very extensive one, and naturalists differ much as to the manner of subdividing it. One of the most remarkable and interesting circumstances connected with these beautiful insects is their series of transformations before reaching a perfect state. The female butterfly lays a great quantity of eggs, which produce larvæ, commonly called caterpillars. After a short life these assume a new form, and become chrysalids or pupæ. These chrysalids are attached to other bodies in various ways, and are of various forms; they often have brilliant golden or argentine spots. Within its covering the insect develops, to emerge as the active and brilliant butterfly. These insects in their perfect form suck the nectar of plants, but take little food, and are all believed to be short-lived, their work in the perfect state being almost confined to the propagation of the species. Butterflies vary greatly in size and colouring, but most of

them are very beautiful. The largest are found in tropical countries, where some measure nearly a foot across the wings. They may generally be distinguished from moths by having their wings erect when sitting, the moths having theirs horizontal. Some of them have great powers of flight. Among the most remarkable butterflies are those that present an extraordinary likeness to other objects—leaves, green or withered, flowers, bark, &c., a feature that serves greatly to protect them from enemies. See *Lepidoptera* and *Mimicry*.

**Butterfly-fish.** See *Blenny*.

**Butterfly-weed**, *Asclēpias tuberōsa* (see *Asclepias*), the pleurisy-root of America, where it has a considerable reputation as an article of the materia medica. It is an expectorant, a mild cathartic, and a diaphoretic, and is employed in incipient pulmonary affections, rheumatism, and dysentery.

**Butterine** (-ēn), an artificial butter, prepared from beef suet, milk, butter, and vegetable oil, and now largely made in Britain, the United States, Holland, &c. By the use of colouring matters it can be made to resemble butter of any given brand; but although quite wholesome when well made, it has not the delicate flavour and aroma of the highest-class butters. To prevent fraudulent sales Congress has passed a law requiring under penalty that every package containing artificial butter shall be duly marked, and that retail dealers shall not sell except from the original package.

**Buttermilk**, the milk from which butter has been extracted, forming a nutritious and agreeable cooling beverage with an acidulous taste.

**Butter-nut**, the fruit of *Juglans cinērea*, or white walnut, an American tree, so called from the oil it contains. The tree bears a resemblance in its general appearance to the black walnut, but the wood is not so dark in colour. The same name is given to the nut of *Caryocar butyracēum* and *C. nucifērum* of South America, also known as *Suwarrow* or *Suwarra nut*.

**Butter-tree**, a name of several trees yielding oily or fatty substances somewhat resembling butter. See *Bassia*, *Shea*.

**Butterwort**, *Pinguicūla vulgāris*, order *Lentibulariaceæ*, a plant growing in bogs or soft grounds in Europe, Canada, &c. The leaves are covered with soft, pellucid, glandular hairs, which secrete a glutinous liquor that catches small insects. The edges of the leaf roll over on the insect and retain it, and



the insect thus retained serves as food for the plant. In the north of Sweden the leaves are employed to curdle milk.

**Buttmann** (but'mán), PHILIP KARL, a German philologist, born in 1764. He spent most of his life at Berlin, where he taught in the Joachimsthal University. His best-known works are his Greek Grammar and *Lexilogus* for Homer and Hesiod. He died in 1829.

**Buttons** are of almost all forms and materials—wood, horn, bone, ivory, steel, copper, silver, brass, &c.—which are either left naked or covered with silk or some other material. The material of buttons has varied much with times and fashions. In the last century gilt, brass, or copper buttons were almost universal. Birmingham was the great seat of manufacture, as it yet is of metallic and other buttons. The introduction of cloth-covered buttons early in the present century made a great revolution in the trade, and led to great varieties in the style of making up. The metal buttons now used are commonly made of brass or a mixture of tin and brass. They are usually made from sheets of metal by punching and stamping. Such buttons are generally used for trousers. A substance now very commonly used for buttons is vegetable ivory (seeds of the ivory-nut palm), which may be coloured according to taste. Mother-of-pearl buttons are another common kind. Of late years the making of porcelain buttons has developed into a remarkable industry. These buttons are both strong and cheap. Besides these kinds there are also glass buttons, made by softening the glass by heat and pressing it into a mould; buttons of vulcanite, marble, and many other materials; but these are fancy articles in the trade.

**Buttonwood**, a name often given to the N. American plane (*Platanus occidentalis*).

**Buttresses**, in architecture, especially Gothic, projections on the outside of the walls of an edifice, extending from the bottom to

the top, or nearly, and intended to give additional support to the walls and prevent them from spreading under the weight of the roof. *Flying buttresses*, of a somewhat arched form, often spring from the top of the ordinary buttresses, leaning inwards so as to abut against and support a higher portion of the building, such as the wall of a clear-story, thus receiving part of the pressure from the weight of the roof of the central pile.

**Butyric Acid**, an acid obtained from butter; it also occurs in perspiration, cod-liver oil, &c. Butyric acid is a colourless liquid, having a smell like that of rancid butter; its taste is acrid and biting, with a sweetish after-taste.

**Butyric Ether**, a substance obtained from butyric acid with the flavour of pine-apples, used in flavouring confectionery, as an ingredient in perfumes, &c.

**Buxar'**, a town of Bengal, on the Ganges, 350 miles N.W. of Calcutta. Pop. 16,498.

**Buxton**, a small town in the county of Derby, England, situated in a valley celebrated for its mineral waters. The accommodation for visitors who come to drink the waters includes hotels and lodging-houses, baths, assembly-rooms, and pump-room. The surrounding scenery is fine, and there is a vast stalactite cavern called Poole's Hole in the neighbourhood. Pop. 7424.

**Buxton**, SIR THOMAS FOWELL, English philanthropist, born in 1786, and educated at Trinity College, Dublin. In 1811 he joined the firm of the celebrated brewers, Truman, Hanbury, & Co., and took an active share in the business. The Spitalfields distress in 1816 was the occasion of his turning his attention to philanthropic efforts, and along with his sister-in-law, the celebrated Mrs. Fry, he made inquiries which directed public attention to the system of prison discipline. In 1818 he was elected M.P. for Weymouth, and was long the able coadjutor of Wilberforce in his efforts for the abolition of slavery. He was created a baronet in 1840 and died in 1845.

**Buxtorf**, JOHANN, a German orientalist, was born in 1564, and became professor at Basel, where he died in 1629. His chief work is *Lexicon Chaldaicum Talmudicum et Rabbinicum*. His son Johann, born at Basel, was equally eminent as a Hebrew scholar, and succeeded to his father's chair. He died in 1664.

**Buxus**. See *Box-tree*.

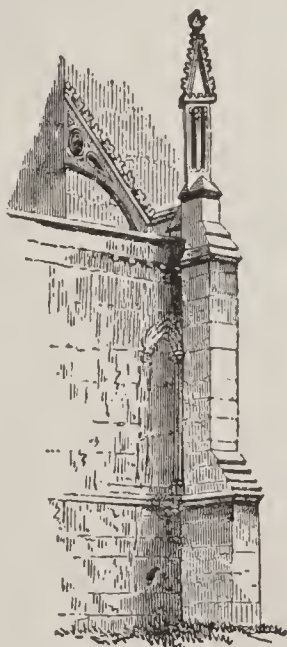

Buttress and Flying Buttress.

**Buyuk'dereh**, a town on the European shore of the Bosphorus, a few miles from Constantinople. It is famous for its scenery, and is a favourite residence of the Christian ambassadors.

**Buz'zard**, the name of raptorial birds which form one of the sub-families of the diurnal birds of prey; characters, a moderate-sized beak, hooked from the base, long wings, long tarsi, and short weak toes. The common buzzard (*Butō vulgaris*) is distributed over the whole of Europe as well as the north of Africa and America. Its food is very miscellaneous, and consists of moles, mice, frogs, toads, worms, insects, &c. It is sluggish in its habits. Its length is from 20 to 22 inches. The rough-legged buzzard (*B. lagopus*), so called from having its legs feathered to the toes, is also a native of Britain. Its habits resemble those of the common buzzard. The red-tailed hawk of the U. States is a buzzard (*B. borealis*). It is also called hen-hawk, from its raids on the poultry-yard. The genus *Pernis*, to which the honey-buzzard (*P. apivorus*) belongs, has the beak rather weaker than *Buteo*, but does not differ much from that genus. The honey-buzzard is so called because feeding specially on bees and wasps.

**Byb'los**, an ancient maritime city of Phœnicia, now called Jebail, a little north of Beyrout. It was the chief seat of the worship of Adonis or Thammuz.

**By-law**, BYE-LAW (from the Scand. *by*, a town), a law made by an incorporated or other body for the regulation of its own affairs, or the affairs intrusted to its care. Town-councils, railway companies, &c., enact by-laws which are binding upon all coming within the sphere of the operations of such bodies. By-laws must of course be within the meaning of the charter of incorporation and in accordance with the law of the land.

**Byng**, JOHN, British admiral, born 1704, entered the navy in 1727, and served under his father, Admiral George Byng. He was sent to relieve Minorca, blockaded by a French fleet, but failed, it was thought, through hesitation in engaging the enemy. The public odium of the failure was such that the ministry allowed Byng, who was condemned by a court-martial, to be shot at Portsmouth, March 14, 1757.

**By'rom**, JOHN, English poet and stenographer, born 1692, died 1763. He was educated at Merchant Taylors' School and Trinity College, Cambridge, and for some

time studied medicine, but his chief means of livelihood for many years, till he inherited the family estates in 1740, was teaching shorthand on a system invented by himself. He was on friendly terms with many of the eminent men of his time. His earliest writings were a few papers to the Spectator; his poems (collected in 1773) were chiefly humorous and satirical, and show remarkable facility in rhyming.

**By'ron**, GEORGE GORDON NOEL, LORD BYRON, a great English poet, was born in Holles Street, London, Jan. 22, 1788. He was the grandson of Admiral John Byron (see that article), and son of the admiral's only son, Captain John Byron, of the Guards, so notorious for his gallantries and reckless dissipation that he was known as 'Mad Jack Byron.' His mother was Catherine Gordon of Gight, in Aberdeenshire,



Lord Byron.

who was left a widow in 1791. Mrs. Byron retired with the infant poet to Aberdeen, where she lived in seclusion on the ruins of her fortune. Till the age of seven he was entirely under the care of his mother, and to her injudicious indulgence the waywardness that marked his after career has been partly attributed. On reaching his seventh year he was sent to the grammar-school at Aberdeen, and four years after, in 1798, the death of his grand-uncle gave him the titles and estates of the family. Mother and son then removed to Newstead Abbey, the family seat, near Nottingham. Soon after Byron was sent to Harrow, where he distinguished himself by his love of manly sports and his undaunted spirit. While yet at school he fell deeply in love with Miss Chaworth, a distant cousin of his own. But

the lady slighted the homage of the Harrow school-boy, her junior by two years, and married another and more mature suitor. In *The Dream* Byron alludes finely to their parting interview. In 1805 he was entered of Trinity College, Cambridge. Two years after, in 1807, appeared his first poetic volume, *Hours of Idleness*, which, though indeed containing nothing of much merit, was castigated with overseverity by Brougham in the *Edinburgh Review*. This caustic critique roused the slumbering energy in Byron, and drew from him his first really notable effort, the celebrated satire *English Bards and Scotch Reviewers*. In 1809, in company with a friend, he visited the southern provinces of Spain, and voyaged along the shores of the Mediterranean. The fruit of these travels was the fine poem of *Childe Harold's Pilgrimage*, the first two cantos of which were published on his return in 1812. The poem was an immense success, and Byron 'awoke one morning and found himself famous.' His acquaintance was now much courted, and his first entry on the stage of public life may be dated from this era. During the next two years (1813-14) the *Giaour*, the *Bride of Abydos*, the *Corsair*, *Lara*, and the *Siege of Corinth* showed the brilliant work of which the new poet was capable. On the 2d of January, 1815, Byron married Anna Isabella, only daughter of Sir Ralph Milbanke, but the marriage turned out unfortunate, and in about a year, Lady Byron having gone on a visit to her parents, refused to return, and a formal separation took place. This rupture produced a considerable sensation, and the real cause of it has never been satisfactorily explained. It gave rise to much popular indignation against Byron, who left England, with an expressed resolution never to return. He visited France, the field of Waterloo and Brussels, the Rhine, Switzerland, and the north of Italy, and for some time took up his abode at Venice, and latterly at Rome, where he completed his third canto of *Childe Harold*. Not long after appeared the *Prisoner of Chillon*, *The Dream*, and other Poems; and in 1817 *Manfred*, a tragedy, and the *Lament of Tasso*. From Italy he made occasional excursions to the islands of Greece, and at length visited Athens, where he sketched many of the scenes of the fourth and last canto of *Childe Harold*. In 1819 was published the romantic tale of *Mazeppa*, and the same year was marked by the commencement of *Don*

*Juan*. In 1820 appeared *Marino Faliero*, Doge of Venice, a tragedy; the drama of *Sardanapalus*; the *Two Foscari*, a tragedy; and *Cain*, a mystery. After leaving Venice Byron resided for some time at Ravenna, then at Pisa, and lastly at Genoa. At Ravenna he became intimate with the Countess Guiccioli, a married lady; and when he removed to Pisa, in 1822, she followed him. There he continued to occupy himself with literature and poetry, sustained for a time by the companionship of Shelley, one of the few men whom he entirely respected and with whom he was quite confidential. Besides his contributions to the *Liberal*, a periodical established at this time in conjunction with Leigh Hunt and Shelley, he completed the later cantos of *Don Juan*, with Werner, a tragedy, and the *Deformed Transformed*, a fragment. These are the last of Byron's poetical efforts. In 1823, troubled perhaps by the consciousness that his life had too long been unworthy of him, he conceived the idea of throwing himself into the struggle for the independence of Greece. In January, 1824, he arrived at Missolonghi, was received with the greatest enthusiasm, and immediately took into his pay a body of 500 Suliotes. The disorderly temper of these troops, and the difficulties of his situation, together with the malarious air of Missolonghi, began to affect his health. On the 9th April, 1824, while riding out in the rain, he caught a fever, which ten days later ended fatally. Thus, in his thirty-seventh year, died prematurely a man whose natural force and genius were perhaps superior to those of any Englishman of his time, and, largely undisciplined as they were, and wasted by an irregular life, they acquired for him a name second, in the opinion of continental Europe at least, to that of no other Englishman of his time. The body of Byron was brought to England and interred near Newstead Abbey.

**Byron, HENRY JAMES**, English dramatist and actor, born 1834, died 1884. He wrote an immense number of pieces, including a great many farces, burlesques, and extravaganzas, besides comedies or domestic dramas, such as *Cyril's Success*; *Dearer than Life*; *Blow for Blow*; *Uncle Dick's Darling*; the *Prompter's Box*; *Partners for Life*; and *Our Boys*, which had an extraordinary success.

**Byron, JOHN**, an English admiral, grandfather of the poet Lord Byron, was born in 1723. Embarking as midshipman in one of

the ships of Lord Anson, which was wrecked on the Pacific coast (1741), north of the Straits of Magellan, he published a narrative of his adventures amongst the Indians, which is extremely interesting. In 1758 he commanded three ships of the line, and distinguished himself in the war against France. In June, 1764, he set out in a frigate to circumnavigate the globe, returning to England in May, 1766. From 1769 to 1775 he was governor of Newfoundland. He was made vice-admiral of the white in 1779, and died in 1786.

**Byssus**, a name given to the hair or thread-like substance (called also *beard*), with which the different kinds of sea-mussels fasten themselves to the rocks. The *Pinna nobilis*, particularly, is distinguished by the length and the silky fineness of its beard, from which cloths, gloves, and stockings are still manufactured (mainly as curiosities) in Sicily and Calabria.

**Bytneria'ceæ**, a nat. order of plants allied to the mallows. Almost all the species contain a fatty oil in their seeds, and have a fibrous bast. The typical genus is *Bytneria*, from which the order is named, but by far the most important is *Theobrōma* to which the tree yielding cocoa (cacao) belongs.

**Byzan'tine Art**, a style which arose in South-eastern Europe after Constantine the Great had made Byzantium the capital of the Roman Empire (330 A.D.), and ornamented that city, which was called after him, with all the treasures of Grecian art. (See *Byzantine Empire*). One of the chief influences in Byzantine art was Christianity, and to a certain extent Byzantine art may be recognized as the endeavour to give expression to the new elements which Christianity had brought into the life of men. The tendency towards Oriental luxuriance and splendour of ornament now quite supplanted the simplicity of ancient taste. Richness of material and decoration was the aim of the artist rather than purity of conception. Yet the classical ideals of art, and in particular the traditions of technical processes and methods carried to Byzantium by the artists of the Western Empire, held their ground long enough, and produced work pure and powerful enough, to kindle the new artistic life which began in Italy with Cimabue and Giotto.

With regard to *sculpture* the statues no longer displayed the freedom and dignity of ancient art. The true proportion of parts,

the correctness of the outlines, and in general the severe beauty of the naked figure, or of simple drapery in Greek art, were neglected for extravagant costume and ornamentation and petty details. Yet in the best period of Byzantine art, from the 6th to the 11th century, there is considerable spiritual dignity in the general conception of the figures. But sculpture was of second-rate importance at Byzantium, the taste of those times inclining more to mosaic work with the costliness and brilliant colours of its stones. The first germ of a Christian style of art



Byzantine Architecture.

Part of the Nave of the Palatine Chapel, Palermo.

was developed in the Byzantine *pictures*. The artists, who appear to have seldom employed the living model, and had nothing real and material before them, but were obliged to find, in their own imaginations, conceptions of the external appearance of sacred persons, such as the mother of Christ or the apostles, could give but feeble renderings of their ideas. As they cared but little

for a faithful imitation of nature, but were satisfied with repeating what was once acknowledged as successful, it is not strange that certain forms, approved by the taste of the time, should be made, by convention, and without regard to truth and beauty, general models of the human figure, and be transmitted as such to succeeding times. In this way the artists in the later periods did not even aim at accuracy of representation, but were contented with stiff general outlines, lavishing their labour on ornamental parts.

Byzantine architecture may be said to have assumed its distinctive features in the church of St. Sophia built by Justinian in the 6th century, and still existing as the chief mosque in Constantinople. It is more especially the style associated with the Greek Church as distinguished from the Roman. The

leading forms of the Byzantine style are the round arch, the circle, and in particular the dome. The last is the most conspicuous and characteristic object in Byzantine buildings, and the free and full employment of it was arrived at when by the use of pendentives the architects were enabled to place it on a square apartment instead of a circular or polygonal. In this style of building incrustation, the incrustation of brick with more precious materials, was largely in use. It depended much on colour and surface ornament for its effect, and with this intent mosaics wrought on grounds of gold or of positive colour are profusely introduced, while coloured marbles and stones of various kinds are greatly made use of. The capitals are of peculiar and original design, the most characteristic being square and tapering downwards, and they are very varied in their decorations. Byzantine architecture may be divided into an older and a newer (or Neo-Byzantine) style.



Byzantine Architecture.—Ancient Cathedral, Athens.

The most distinctive feature of the latter is that the dome is raised on a perpendicular circular or polygonal piece of masonry (technically the *drum*) containing windows for lighting the interior, while in the older style the light was admitted by openings in the dome itself. The Cathedral of Athens (shown in the accompanying cut) is an example of the Neo-Byzantine style. The Byzantine style had a great influence on the architecture of

Western Europe, especially in Italy, where St. Mark's in Venice is a magnificent example, as also in Sicily. It had also material influence in Southern France and Western Germany.

Byzantine Empire, the Eastern Roman Empire, so called from its capital Byzantium or Constantinople. The Byzantine Empire was founded in A.D. 395, when Theodosius at

his death divided the Roman Empire between his sons Arcadius and Honorius. In this empire the Greek language and civilization were prevalent; but the rulers claimed still to be Roman emperors, and under their sway the laws and official forms of Rome were maintained. It lasted for about a thousand years after the downfall of the Western Empire. It is also known as the *Greek Empire* or *Lower Empire*. Its capital was naturally Constantinople, a city established by Constantine in 330 as the new capital of the whole Roman Empire.

The Eastern Empire, then comprising Asia Minor, Syria, Egypt, Greece, Thrace, Mœsia, Macedonia, and Crete, fell to Theodosius's elder son Arcadius, through whose weakness and that of several of his immediate successors it suffered severely from the encroachments of Huns, Goths, Bulgarians, and Persians. In 527 the celebrated Justinian succeeded, whose reign is famous

## BYZANTINE EMPIRE.

for the codification of Roman law, and the victories of his generals Belisarius and Narses over the Vandals in Africa, and the Goths in Italy, which was henceforth governed for the Eastern Empire by an *exarch* residing at Ravenna. But his energy could not revive the decaying strength of the empire, and Justin II. his successor (565–578), a weak and avaricious prince, lost his reason by the reverses encountered in his conflicts with plundering Lombards, Avars, and Persians. Tiberius, a captain of the guard, succeeded in 578, and in 582 Mauricius; both were men of ability. In 602 Phocas, proclaimed emperor by the army, succeeded, and produced by his incapacity the greatest disorder in the empire. Heraclius, son of the governor of Africa, who headed a conspiracy, conquered Constantinople, and caused Phocas to be executed (610). He was an excellent general, and finally succeeded in repressing the Avars and recovering the provinces lost to the Persians, whose power indeed he overthrew. But a far more dangerous enemy to the Byzantine empire now appeared in the Moslem power, founded amongst the Arabians by Mohammed and the caliphs, which gradually extended its conquests over Phœnicia, the countries on the Euphrates, Judea, Syria, and Egypt (635–641). In 641 Heraclius died, nor was there amongst his descendants a single prince capable of stemming the tide of Moslem invasion. The Arabians took part of Africa, Cyprus, and Rhodes (653), inundated Africa and Sicily, penetrated into Thrace, and attacked Constantinople by sea.

The empire was in sore straits when Leo the Isaurian (Leo III.), general of the army of the East, mounted the throne (716), and a new period of comparative prosperity began. Some writers date the beginning of the Byzantine Empire proper, and the end of the Eastern Roman Empire, from this era. Numerous reforms, civil and military, were now introduced, and the worship of images was prohibited. Leo repelled the Arabians or Saracens from Constantinople, but allowed the Lombards to seize the Italian provinces, while the Arabians plundered the Eastern ones. Constantine V. (741) recovered part of Syria and Armenia from the Arabians; and the struggle was carried on not unsuccessfully by his son Leo IV. Under his grandson, Constantine VI., Irene, the ambitious mother of the latter, raised a large faction by the restoration of image wor-

ship, and, in conjunction with her paramour Stauratius, deposed her son, and had his eyes put out (797). A revolt of the patricians placed one of their order, Nicephorus, on the throne, who fell in the war against the Bulgarians (811). Stauratius, Michael, Leo V. and Michael II. (820) ascended the throne in rapid succession. During the reign of the latter the Arabians conquered Sicily, Lower Italy, Crete, and other countries. The long dispute as to image-worship was brought to a close in 842, when the practice was finally sanctioned at the council of Nicæa, under Michael III. He was put to death by Basil the Macedonian, who came to the throne as Basil I. in 867, and whose reign formed a period of great glory in the history of the Byzantine Empire. He founded a dynasty (the *Macedonian*) which lasted till 1056. Among the greatest of his successors were Nicephorus II. (Phocas), and John Zimisces (969), who carried on successful wars against the Mohammedans, Bulgarians, and Russians. Basil II. succeeded this prince in 976. He vanquished the Bulgarians and the Arabians. His brother, Constantine IX. (1025), was succeeded by Romanus III. (1028), who married Zoe, daughter of Constantine. This dissolute but able princess caused her husband to be executed, and successively raised to the throne Michael IV. (1034), Michael V. (1041), and Constantine X. (1042). Russians and Mohammedans meanwhile devastated the empire. Her sister Theodora succeeded her on the throne (1054).

After the short reign of Michael VI. (1054–57) Isaac Comnenus, the first of the *Comnenian* dynasty, ascended the throne, but soon after became a monk. The three chief emperors of this dynasty were Alexius, John, and Manuel Comnenus. During the reign of Alexius I. (1081–1118) the Crusades commenced. His son, John II., and grandson, Manuel I., fought with success against the Turks, whose progress also was considerably checked by the Crusades. The Latins, the name given to the French, Venetian, &c., crusaders, now forced their way to Constantinople (1204), conquered the city, and retained it, together with most of the European territories of the empire. Baldwin, count of Flanders, was made emperor; Boniface, marquis of Montferrat, obtained Thessalonica as a kingdom, and the Venetians acquired a large extent of territory. Theodore Lascaris seized on the Asiatic provinces, in 1206 made Nice

(Nicæa) the capital of the empire, and was at first more powerful than Baldwin. Neither Baldwin nor his successors, Henry, Peter, and Robert of Courtenay, were able to secure the tottering throne. John, emperor of Nice, conquered all the remaining Byzantine territory except Constantinople, and at last, in 1261, Michael Palæologus, king of Nice, conquered Constantinople, and thus overthrew the Latin dynasty.

Thus again the vast but exhausted Byzantine Empire was united under Michael Palæologus, founder of the last Byzantine dynasty. Internal disturbances and wars with the Turks disturbed the reigns of his descendants Andronicus II. and Andronicus III. For a time the Cantacuzenes shared the crown with John Palæologus, son of Andronicus III.; but in 1355 John again became sole emperor. In his reign the Turks first obtained a firm footing in Europe, and conquered Gallipoli (1357). In 1361 Sultan Amurath took Adrianople. Bajazet conquered almost all the European provinces except Constantinople, and was pressing it hard when Timur's invasion of the Turkish provinces saved Constantinople for this time (1402). Manuel then recovered his throne, and regained some of the lost provinces from

the contending sons of Bajazet. To him succeeded his son John, Palæologus II. (1425), whom Amurath II. stripped of all his territories except Constantinople, and laid under tribute (1444). To the Emperor John succeeded his brother Constantine Palæologus. With the assistance of his general Giustiniani, a Genoese, he withstood the superior forces of the enemy with fruitless courage, and fell in the defence of Constantinople, by the conquest of which (May 29, 1453) Mohammed II. put an end to the Greek or Byzantine Empire. The Byzantine Empire, which thus lasted for over a thousand years, was of immense service to the world in stemming the tide of Mohammedan advance, in spreading Christianity and civilization, and in maintaining a regular system of government, law, and policy in the midst of surrounding barbarism.

**Byzan'tium**, the original name of the city of Constantinople. It was founded by Greek colonists in 658 B.C., and owing to its favourable position for commerce it attained great prosperity, and survived the decay of most of the other Greek cities. In A.D. 330 a new era began for it when Constantine the Great made it the capital of the Roman Empire. See *Constantinople*.

## C.

**C**, the third letter in the English alphabet and the second of the consonants. In English it serves to represent two perfectly distinct sounds, namely, the guttural sound pertaining to *k* and the hard or thin sound of *s*, the former being that which historically belongs to it; while it also forms with *h* the digraph *ch*. The former sound it has before the vowels *a*, *o*, and *u*, the latter before *e*, *i*, and *y*. The digraph *ch* has three different sounds, as in *church*, *chaise*, and *chord*. To these the Scotch adds a fourth, heard in the word *loch*.

**C**, in music, (*a*) after the clef, the mark of common time, in which each measure is a semibreve or four minims, corresponding to  $\frac{2}{2}$  or  $\frac{4}{4}$ ; and when a bar is perpendicularly drawn through it *alla-breve* time or a quicker movement is indicated. (*b*) The name of the first or key-note of the modern normal scale, answering to the *do* of the Italians and the *ut* of the French.

**Caaba** (kä'ä-bä). See *Kaaba*.

**Caaling Whale** (kä'ing; Scotch name,

meaning 'driving whale,' whale that may be driven), the round-headed porpoise (*Globicephalus deductor*, *Delphinus melas*, or *D. globiceps*), a cetaceous animal of the dolphin family, characterized by a rounded muzzle and a convex head, attaining a size of 16 to 24 feet. It frequents the shores of Orkney, Shetland, the Faroe Islands, and Iceland, appearing in herds of from 200 to 1000, and numbers are often caught. They live on cod, ling, and other large fish, and also on molluscs, especially the cuttle-fishes.

**Caama** (kä'mä). See *Hartebeest*.

**Cab** (short for the original name *cabriolet*), a kind of hackney-carriage with two or four wheels drawn by one horse. The original cab was for only one passenger besides the driver, and was a kind of hooded chaise.

**Cabal'**, in English history applied to the ministry under Charles II., which consisted of Sir Thomas, afterwards Lord Clifford, Lord Ashley, afterwards Earl of Shaftesbury, George Villiers, Duke of Buckingham, Henry, Lord Arlington, and John, Duke of

Lauderdale; the initials of whose names happened to compose the word *cabal*. This term (which existed long before, and was derived from *cabala*) is applied to any junto united in some close design, usually to promote their private ends by intrigue.

**Cab'ala**, or CAB'BALA, a mysterious kind of science or knowledge among Jewish rabbins, pretended to have been delivered to the ancient Jews by revelation—specifically to Moses on Sinai—and transmitted by oral tradition, serving for the interpretation of difficult passages of Scripture. This science consists chiefly in understanding the combination of certain letters, words, and numbers which are alleged to be significant. Every letter, word, number, and accent of the law is supposed to contain a mystery, and the cabalists pretend even to foretell future events by the study of this science.

**Caballero** (kà-bà-lyer'ō), FERNAN, pseudonym of Cecilia Böhl von Faber, the chief modern Spanish novelist, daughter of a German settled in Spain and married to a Spanish lady; born 1797, died 1877. Her first novel, *La Gaviota*, appeared in 1849, and was followed by *Elia*, *Clemencia*, *La Familia de Alvareda*, &c., as well as by many shorter stories. The chief charm of her writings lies in her descriptions of life and nature in Andalusia. She was three times left a widow; her last husband's name was De Arrom.

**Cab'anis**, PIERRE JEAN GEORGES, French physician, philosopher, and *littérateur*, born 1757, died 1808. He became acquainted with Madame Helvetius, and through her with Holbach, Franklin, and Jefferson, and became the friend of Condillac, Turgot, and Thomas. He professed the principles of the revolution, and was intimately connected with Mirabeau. His *Rapports du Physique et du Moral de l'Homme* is his most important work. It displays considerable power of analysis, and advocates the most extreme materialistic doctrines. He afterwards changed his opinions and adopted theistic views.

**Cabatuan'**, a town on the island of Panay, one of the Philippines. Pop. 23,000.

**Cabaze'ra**, a town in the island of Luzon, Philippines. Pop. 15,000.

**Cabbage**, the popular name of various species of cruciferous plants of the genus *Brassica*, and especially applied to the plain-leaved, hearting, garden varieties of *B. oleracëa*, cultivated for food. The wild cab-

bage is a native of the coasts of Britain, but is much more common on other European shores. The kinds most cultivated are the common cabbage, the savoy, the broccoli, and the cauliflower. The common cabbage forms its leaves into heads or bolls, the inner leaves being blanched. Its varieties are the white, the red or purple, the tree or cow cabbage for cattle (branching and growing when in flower to the height of 10 feet), and the very delicate Portugal cabbage. The garden sorts form valuable culinary vegetables, and are used at table in various ways. In Germany pickled cabbage forms a sort of national dish, known as *sauer-kraut*.

**Cabbage-bark**. See *Andira*.

**Cabbage-but'erfly**, a name given to several species of butterfly, especially *Pontia* or *Pieris brassica*, a large white butterfly, the larvæ of which destroy cruciferous plants, particularly of the cabbage tribe.

**Cabbage-fly** (*Anthomyia brassica*), a fly belonging to the same family (Muscidæ) as the house-fly and the same genus as the turnip and potato flies. Its larvæ or maggots are destructive to cabbages by producing disease in their roots, on which they feed.

**Cabbage-moth**, the *Mamestra* or *Noctua Brassica*, a moth measuring about  $1\frac{3}{4}$  inch across the open fore-wings, which are dusky brown, clouded with darker shades, and marked with dark spots, as also various streaks and spots of a yellowish or white colour. The caterpillar is greenish-black, and is found in autumn feeding on the hearts of cabbages.

**Cabbage-palm**, a name given to various species of palm-trees from the circumstance that the terminal bud, which is of great size, is edible and resembles cabbage, as the *Arëca oleracëa*, a native of the West Indies, the simple unbranched stem of which grows to a height of 150 or even 200 feet. The unopened bud of young leaves is much prized as a vegetable, but the removal of it completely destroys the tree, as it is unable to produce lateral buds.

**Cabbage-rose**, a species of rose (*Rosa centifolia*) of many varieties, supposed to have been cultivated from ancient times, and eminently fitted for the manufacture of rose-water and attar from its fragrance. It has a large, rounded, and compact flower. Called also *Provence Rose*.

**Cabbage-tree**, a name given to the cabbage-palm, and also to a tree of the genus *Andira* (which see).

**Cab'bala**. See *Cabala*.



**Cabeiri.** See *Cabiri*.

**Ca'ber**, the undressed stem of a tree, 20 or more feet long, used at Highland games as a trial of strength, being held upright by the smaller end and tossed so as strike the ground with the other end and turn over.

**Ca'bes**, or KA'BES, a town and port of Tunis, with a small trade. The Gulf of Cebes (*Syrtis Minor*), at the head of which the town is situated, lies between the islands of Kerkenna and Jerba.

**Cabin'da**, a Portuguese seaport and territory, north of the Congo mouth, bounded by the Atlantic, the Congo State, and the French Congo territory. The town carries on a considerable trade, and its people are noted for their shipbuilding and other handicrafts. Pop. 10,000.

**Cab'inet**, the collective body of ministers who direct the government of a country. In Britain, though the executive government is vested nominally in the crown, it resides practically in a committee of ministers called the *cabinet*. Every cabinet includes the first lord of the treasury, who is usually (not always) the prime-minister or chief of the ministry, and therefore of the cabinet; the lord-chancellor, the lord-president of the council, the chancellor of the exchequer, the first lord of the admiralty, and the five secretaries of state. A number of other ministerial functionaries, varying from two to eight, have usually seats in the cabinet, and its members belong to both houses of parliament, but usually adhere to that political party which predominates for the time being in the House of Commons. Its meetings are secret, and no minutes of the proceedings are taken. In the United States government the cabinet consists of the secretaries of state, treasury, war, navy, and interior, the attorney-general, post-master-general, and the secretary of agriculture. They meet whenever desired by the president, but not publicly. No minutes are kept of their proceedings. The president presides.

**Cabi'ri**, CABEIRI, deities or deified heroes worshipped in the ancient Greek islands of Lemnos, Imbros, and Samothrace, and also on the neighbouring coast of Troy in Asia Minor.

**Cable**, a large strong rope or chain, such as is used to retain a vessel at anchor. It is made usually of hemp or iron, but may be made of other materials. A hemp cable is composed of three strands, each strand of three ropes, and each rope of three

twists. A ship's cable is usually 120 fathoms or 720 feet in length; hence the expression *a cable's length*. Chain-cables have now almost superseded rope-cables. Although deficient in elasticity, heavier, and more difficult of management, yet their immunity from chafing and rotting, their greater compactness for stowage, and the fact that from their greater weight the strain is exerted on the cable rather than on the ship, more than counterbalance these drawbacks.—A *submarine telegraph cable* is composed of one or more copper wires embedded in a compound of gutta percha and resinous substances, encircled by layers of gutta percha or india-rubber, hemp or jute padding, and coils of iron wire. There are now (1893) ten cables laid across the North Atlantic ocean: two start from Brest, France; six from the west coast of Ireland; and two from Land's End, England. There are in the world 135,000 miles of cables, of which Great Britain owns 91,000 miles; France, 20,000; and United States, 10,000.

**Cab'ot**, SEBASTIAN, navigator, was born at Bristol about 1474, died about 1557. He was the son of John Cabot, a Venetian



Sebastian Cabot.

pilot, who resided at Bristol, and was highly esteemed for his skill in navigation. In 1497, in company with his father and two brothers, he discovered the mainland of N. America, having visited Nova Scotia and Newfoundland. In 1517 he made an attempt to discover the north-west passage, visiting Hudson's Bay. In 1526, when in the Spanish service, he visited Brazil and the river Plate. In 1548 he again

## CABRA — CACAO.

settled in England, and received a pension from Edward VI. He was the first who noticed the variations of the compass; and he published a large map of the world.

**Cab'ra**, a town of Spain, Andalusia, in the province of Cordova, in a valley almost environed by mountains. The neighbouring region produces excellent wine. Pop. 13,763.

**Cabral'**, PEDRO ALVAREZ, the discoverer (or second discoverer) of Brazil, a Portu-

guese, born about 1460, died about 1526. In 1500 he received command of a fleet bound for the East Indies, and sailed from Lisbon, but having taken a course too far to the west he was carried by the South American current to the coast of Brazil, of which he took possession in name of Portugal. Continuing his voyage, he visited Mozambique, and at last reached India, where he made important commer-



Cabul.— The Bazaar during the Fruit Season.

cial treaties with native princes, and then returned to Europe.

**Cabre'ra**, a small Spanish island, one of the Balearic Isles, used as a place for receiving convicts.

**Cabul**, CABOOL, KABUL (kă-bul'), capital of the kingdom of Afghanistan, 165 miles from the Indian station and fort of Peshawur, 600 from Herat, and 290 from Candahar. It stands on the Cabul river, at an elevation of 6400 feet above sea-level. The citadel, Bala-Hissar, contains the palace and other public buildings, the fort, &c. Cabul carries on a considerable trade with Hindustan through the Khyber Pass. It was taken by the British in 1839 and in 1842, and on the occasion of a subsequent war with the British in 1879 Cabul was twice taken by their troops. Pop. 75,000.— The Cabul river rises in Afghanistan at the

height of about 8400 feet, flows eastward, passes through the Khyber Pass into India, and falls into the Indus at Attock. Length 300 miles.

**Caca'o**, or CO'COA, the chocolate-tree (*Theobroma Cacao*), nat. order Byttneriaceæ, and also the powder and beverage made with it obtained from the fruit of this tree. The tree is 16 to 18 feet high, a native of tropical America, and much cultivated in the tropics of both hemispheres, especially in the West India Islands, Central and South America. Its fruit is contained in pointed, oval, ribbed pods 6 to 10 inches long, each inclosing 50 to 100 seeds in a white, sweetish pulp. These are very nutritive, containing 50 per cent of fat, are of an agreeable flavour, and used, both in their fresh state and when dried, as an article of diet. Cocoa and chocolate are made from them, the

former being a powder obtained by grinding the seeds, and often mixed with other substances when prepared for sale, the latter being this powder mixed with sugar and various flavouring matters and formed into solid cakes. The seeds when roasted and divested of their husks and crushed are known as *cocoa nibs*. The seeds yield also an oil called butter of cacao, used in pomatum and for making candles, soap, &c. The term *cocoa* is a corruption of *cacao*, but is more commonly used in commerce: *cocoa-nuts*, however, are obtained from an entirely different tree.

**Caceres** (kä'the-res), a town of Western Spain, Estremadura, capital of a province of same name, with an episcopal palace, an old castle, and the largest bull-ring in Spain. Pop. 14,204. Pop. of province, 325,953; area, 8013 sq. miles.

**Cachalot** (kash'a-lot). See *Sperm-whale*.

**Cachar'**, an East Indian district in Assam; area, 3750 sq. miles. Pop. 313,858, entirely engaged either in rice cultivation or on the tea plantations.

**Cache** (kash; Fr.), a hole in the ground for hiding and preserving provisions which it is inconvenient to carry: used by settlers in the western states of America and Arctic explorers.

**Cachet** (kä-shā), LETTRE DE, a name given especially to letters proceeding from and signed by the kings of France, and countersigned by a secretary of state. They were at first made use of occasionally as a means of delaying the course of justice but they appear to have been rarely employed before the 17th century as warrants for the detention of private citizens, and for depriving them of their personal liberty. During the reign of Louis XIV. their use became frightfully common, and by means of them persons were imprisoned for life or for a long period on the most frivolous pretexts. They were abolished at the Revolution.

**Cachexy** (ka-kek'si), CACHEXIA (Gr., 'evil habit of body'), a morbid state of the bodily system, in which there is great weakness, with or without the local manifestation of some constitutional disease. It is not a disease of itself, but the result of disease.

**Cachoeira** (kä-sho-ā'i-rà), a town of Brazil, in the province and 62 miles N.W. of Bahia. Pop. 15,000.

**Cacholong** (kash'o-long), a mineral of the quartz family, a variety of opal, and so often called *Pearl-opal*, usually milk-white, some

times grayish or yellowish-white, opaque or slightly translucent at the edges.

**Cacholot**. See *Cachalot*.

**Cachou** (ka-shö'), a sweetmeat in the form of a pill, made from the extract of liquorice, cashew-nut, gum, &c., used by smokers to sweeten the breath.

**Cachuca** (ká-chö'ká), a Spanish dance performed by a man and woman to a lively, graceful air in triple time and with a strongly marked accent.

**Cacique** (ka-sék'), in some parts of America the title of the native chiefs at the time of the conquest by the Spaniards.

**Cac'odyle**. See *Kakodyle*.

**Cac'olet**, a contrivance somewhat resembling a double arm-chair, or in other cases like a bed, fixed on the back of a mule or horse for carrying sick persons or travellers in mountainous countries.

**Cacon'go**, or MALLEMBA, a district on the west coast of Africa, immediately north of the Congo river. The chief town is Kinguela.

**Cactus**, a Linnæan genus of plants, now used as a name for any of the Cactaceæ, a natural order of dicotyledons, otherwise called the Indian fig order. The species



Cacti.

1, *Echinocactus centeterius*. 2, *E. oxygönus*.

are succulent shrubs, with minute scale-like leaves (except in the genus *Pereskia*, tree-cactus, with large leaves), and with clusters and spines on the stems. They have fleshy stems, with sweetish watery or milky juice, and they assume many peculiar forms. The juice in some species affords a refreshing beverage where water is not to be got. All the plants of this order, except a single species, are natives of America. They are generally found in very dry localities. Some are epiphytes. Several have been introduced into the Old World, and in many places they have become naturalized. The fruits of some species are edible, as the prickly-pear

and the Indian fig, cultivated throughout the Mediterranean region. The flowers are usually large and beautifully coloured, and many members of the order are cultivated in hot-houses. The principal genera are *Melocactus*, *Echinocactus*, *Opuntia*, *Cereus*, and *Mammillaria*.

**Cadamosto**, ALOIS DA, an early navigator, was born at Venice about 1432, died 1464. He explored the west coast of Africa as far south as the Gambia. His Book of the First Voyage over the Ocean to the Land of Negroes in Lower Ethiopia was published in 1507.

**Cadas'tral Survey**, a detailed survey of the lands of a country, their extent, divisions, and subdivisions, nature of culture, &c.; in most countries executed by the government as the basis of an assessment for fiscal purposes.

**Caddis-fly**, an insect of the genus *Phryganea*, order Neuroptera, called also the *May-fly*, the larva or grub of which (caddis or case worm) forms for itself a case of small stones, grass-roots, shells, &c., lives under water till ready to emerge from the pupa state, and is used as bait by anglers. This grub is very rapacious, and devours large quantities of fish-spawn.

**Cade**, JOHN (better known as *Jack Cade*), a popular agitator of the 15th century, leader of an insurrection of the common people of Kent (1450) in the reign of Henry VI. Having defeated a force sent against him he advanced to London, which he ruled for two days. On a promise of pardon being given the rebels soon dispersed, but Cade himself was killed by a gentleman of Kent named Iden.

**Ca'dence**, the concluding notes of a musical composition or of any well-defined section of it. A cadence is *perfect*, *full*, or *authentic* when the last chord is the tonic preceded by the dominant; it is *imperfect* when the chord of the tonic precedes that of the dominant; it is *plagal* when the closing tonic chord is preceded by that of the subdominant; and it is *interrupted*, *false*, or *deceptive* when the bass rises a second, instead of falling a fifth. Cadence, or *cadenza*, is the name also given to a running passage which a performer may introduce at the close of a movement.

**Ca'dency**, MARKS OF, in heraldry, marks intended to show the descent of a younger branch of a family from the main stock.

**Caden'za**. See *Cadence*.

**Cader Idris**, a mountain mass about 10

miles long in Merionethshire, Wales. The highest peak is 2914 feet above the level of the sea.

**Cadet'** (French), a younger or youngest son; a junior male member of a noble family. Also the name or title given to a young man in training for the rank of an officer in the army or navy, or in a military school. In Britain cadets are trained for the army by a course of military discipline, at the Royal Military Academy at Woolwich, or the Royal Military College at Sandhurst, previous to obtaining a commission. A naval cadet is one who holds the first or lowest grade as a candidate for a commission in the Royal Navy. In the United States academies for cadets are at West Point, N. Y., and Annapolis, Md.

**Ca'di**, or KADI, in Arabic, a judge or jurist. Among the Turks *cadi* signifies an inferior judge, in distinction from the *mollah*, or superior judge. They belong to the higher priesthood, as the Turks derive their law from their prophet.

**Cadiz** (*kä-dēth'*; ancient *Gades*), a seaport of south-western Spain, situated at the extremity of a long tongue of land projecting from the island of Leon, which is separated by a narrow (bridged) channel from the coast of Andalusia. It is well built, well paved, and very clean, and is strongly fortified. The chief buildings are the great hospital, the custom-house, the old and new cathedrals, the theatres, the bull-ring, capable of accommodating 12,000 spectators, and the lighthouse of St. Sebastian. The bay of Cadiz is a large basin inclosed by the mainland on one side and the projecting tongue of land on the other, with good anchorage, and protected by the neighbouring hills. It has four forts, two of which form the defence of the grand arsenal, La Carraca (4 miles from Cadiz), at which are large basins and docks. Cadiz has long been the principal Spanish naval station. Its trade is large, its exports being especially wine and fruit. Cadiz was founded by the Phœnicians about B.C. 1100, and was one of the chief seats of their commerce in the west of Europe. Pop. 59,659. — The province of Cadiz is the most southerly in Spain; area, 2809 sq. miles; pop. 431,531.

**Cad'mium**, a scarce metal which resembles tin in colour and lustre, but is a little harder. It is very ductile and malleable; has a specific gravity of 8.6 to 8.69; and fuses a little below a red heat. In its chemical character it resembles zinc. It

## CADMIUM YELLOW — CAEN.

occurs in the form of carbonate, as an ingredient in various kinds of calamine, or carbonate of zinc. It is also found in the form of a sulphide, as the rare mineral greenockite. It forms at least two oxides, one chloride, and one sulphide. Its symbol is Cd, its atomic weight 112.

**Cadmium Yellow**, a pigment prepared from the sulphide of cadmium. It is of an intense yellow colour, and possesses much body.

**Cadmus**, in Greek legend, the son of Agenor and grandson of Poseidon (Neptune). He was said to have come from Phœnicia to Greece about 1550 B.C., and to have built the city of Cadmea or Thebes, in Bœotia. Herodotus and other writers ascribe the introduction of the Phœnician alphabet into Greece to Cadmus. The solar mythists identify him with the sun-god.

**Cadore** (kă-dō'rā), a small town of North Italy, 22 miles N.N.E. of Belluno, the native place of Titian, who was born here in 1477.

**Cadre** (kă'dr), a list of the commissioned and non-commissioned officers of a regiment forming the staff; the nominal establishment of officers of a regiment.

**Cadu'ceus**, Mercury's rod; a winged rod entwisted by two serpents, borne by Mercury as an ensign of quality and office. In modern times it is used as a symbol of commerce, Mercury being the god of commerce.

The rod represents power; the serpents, wisdom; and the two wings, diligence and activity.

**Cæcilia** (*L. cæcus*, blind, from the minute size of their eyes), a genus of amphibians, formerly, on account of their external form,

ranked with the ophidian reptiles. They are entirely destitute of limbs, and the eyes are very small, and nearly hidden by the skin. They are usually 1 to 2 feet in length, but often much longer.

**Cæcum**, a blind process or sac in the alimentary canal of various animals. In fishes they are often numerous and long; and birds have generally two near the termination of the intestine. Mammals have commonly only one *cæcum*. In man the 'blind-gut' is small and situated at the beginning of the colon.

**Cædmon** (kad'mon), the first Anglo-Saxon of note who wrote in

his own language, flourished about the end of the 7th century. He was originally a tenant, or perhaps only a cowherd, on the abbey lands at Whitby, but afterwards was received into the monastery. His chief work (if it can all be attributed to him) consists of paraphrases of portions of the Scriptures, in Anglo-Saxon verse, the first part of which bears striking resemblances to Milton's narrative in *Paradise Lost*.

**Caen** (kæn), a town of France, in Normandy, chief place in dep. Calvados, 125 m.



north-west of Paris, and about 9 miles from the mouth of the Orne, which is here navigable. There is a dock connected with the sea by a canal as well as by the river. It is the centre of an important trade, the market of a rich agricultural district, and carries on extensive manufactures. It is well built, with wide streets, and possesses many old buildings. One of the finest churches is that of St. Pierre, whose tower, terminated by a spire, is exceedingly elegant, and was built in 1308. Two other remarkable churches are St. Etienne or Church of the Abbaye-aux-Hommes, built by William the Conqueror, who was buried in it, and La Ste. Trinité or Church of the Abbaye-aux-Dames, founded by the Conqueror's wife. The buildings of the former abbaye are now used as a college, of the latter as a hospital. Other buildings are the castle and the hôtel de ville. There is a public library of 60,000 volumes, and a botanic garden. Lace is largely made here. Valuable building stone is quarried. (See next article.) Pop. 1891, 45,201.

**Caen-stone**, the French equivalent for the Bath oolite of England, a cream-coloured building-stone of excellent quality, got near Caen in Normandy. Winchester and Canterbury Cathedrals, Henry VII.'s Chapel at Westminster, and many churches are built of it.

**Caer'leon**, a small town in Monmouthshire, 26 miles from Bristol, on the river Usk. It was the site of the *Isca Silurum*, the chief Roman station in the country of the Silures, and Roman coins, statues, and sepulchral monuments are yet found. There are also the vestiges of an amphitheatre. Pop. 1891, 1411.

**Caermarthenshire.** See *Carmarthenshire*.

**Caernarvon.** See *Carnarvon*.

**Caernarvonshire.** See *Carnarvonshire*.

**Cæsalpinieæ**, a subdivision of the natural order of plants Leguminosæ, containing several genera. The typical genus is *Cæsalpinia*, to which belong the Brazil-wood, sapanwood, Nicaragua-wood, &c. The *Cæsalpinieæ* include also among their number senna, the carob, tamarind, aloes-wood, log-wood, &c.

**Cæ'sar**, a title, originally a surname of the Julian family at Rome, which, after being dignified in the person of the dictator Caius Julius Cæsar, was adopted by the successive Roman emperors, and latterly came to be applied to the heir-presumptive to the throne. The title was perpetuated

in the *Kaiser* of the Holy Roman Empire, and in the *Czar* of the Russian emperors.

**Cæ'sar**, CAIUS JULIUS, a great Roman general, statesman, and historian, was born B.C. 100, died B.C. 44. He was the son of the prætor Caius Julius Cæsar, and of Aurelia, a daughter of Aurelius Cotta. At the age of sixteen he lost his father, and shortly after he married Cornelia, the daughter of Lucius Cinna, the friend of Marius.

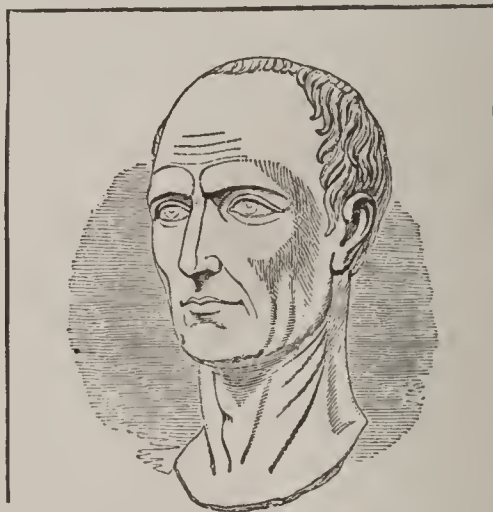

Julius Cæsar.—Marble in Brit. Museum

This connection gave great offence to Sulla, the dictator, who proscribed him for refusing to put away his wife. His friends obtained his pardon with difficulty, and Cæsar withdrew from Rome, and went to Asia, serving his first campaign under M. Minucius Thermus, the prætor in Asia. On the death of Sulla Cæsar returned to Rome, where he distinguished himself as an orator. He afterwards visited Rhodes, when he was taken by pirates, and compelled to pay fifty talents for his release. To revenge himself, he fitted out some vessels at Miletus, overtook the pirates, made the greater number of them prisoners, and had them crucified before Pergamus. He now returned to Rome, where his eloquence and liberality made him very popular. He was pontifex maximus in 63 B.C., prætor in 62 B.C., and governor of Spain in 61 B.C. On his return to Rome, having united with Pompey and Crassus in the memorable coalition called 'the first triumvirate,' he became consul, and then obtained the government of Gaul with the command of four legions. His military career was rapid and brilliant. He compelled the Helvetii, who had invaded Gaul, to retreat to their native country, subdued Ariovistus, who at the head of a German tribe had attempted to settle in the country

of the Ædui, and conquered the Belgæ. In nine years he reduced all Gaul, crossed the Rhine twice (B.C. 55 and 53), and twice passed over to Britain, defeated the gallant natives of this island in several battles, and compelled them to give him hostages. The senate had continued his government in Gaul for another period of five years, while Pompey was to have the command of Spain, and Crassus that of Syria, Egypt, and Macedonia for five years also. But the death of Crassus in his campaign against the Parthians dissolved the triumvirate; and about the same time the friendship between Cæsar and Pompey cooled. The senate, influenced by Pompey, ordered that Cæsar should resign his offices and command within a certain time, or be proclaimed an enemy to the state, and appointed Pompey general of the army of the Republic. Upon this Cæsar urged his soldiers to defend the honour of their leader, passed the Rubicon (49 B.C.), and made himself master of Italy without striking a blow, Pompey retiring into Greece. Cæsar then levied an army with the treasures of the state, and hastened into Spain, which he reduced to submission without coming to a pitched battle with Pompey's generals. He next conquered Massilia (now Marseilles), and returned to Rome, where he was appointed dictator. He then followed Pompey into Greece, and defeated him at Pharsalia, from which Pompey escaped only to be assassinated in Egypt. In Rome the senate and the people strove eagerly to gain the favour of the victor. They appointed him consul for five years, dictator for a year, and tribune of the people for life. When his dictatorship had expired he caused himself to be chosen consul again, and without changing the ancient forms of government, ruled with almost unlimited power. In 46 B.C. he crossed to Africa, defeated the Pompeians Scipio and Cato at Thapsus, and returning to Rome he was received with the most striking marks of honour. The term of his dictatorship was prolonged to ten years, the office of censor conferred on him alone; his person was declared inviolable, and his statue placed beside that of Jupiter in the capitol. He soon after was honoured with four several triumphs, made perpetual dictator, and received the title of *imperator* with full powers of sovereignty. In February, 44, he declined the diadem which Antony publicly offered him, and next morning his statues were decked with diadems. His glory, however, was short-lived, for a

conspiracy was set on foot by his enemy Cassius, and joined by many of his own friends, including M. Brutus; and, notwithstanding dark hints had been given to him of his danger, he attended a meeting of the senate on 15th (ides) March, 44 B.C., and fell beneath the daggers of the conspirators. Of his writings, we still possess the history of his wars with the Gauls and with Pompey. Cæsar was undoubtedly 'the foremost man of all this world,' being great as a statesman, a general, an orator, a historian, and an architect and engineer, and his assassination was brought about more by jealousy and envy than by real patriotism.

**Cæsare'a**, the ancient name of many cities, such as: (1) CÆSAREA PHILIPPI in Palestine, north of the Sea of Galilee, rebuilt by Philip, tetrarch of Galilee, son of Herod the Great.—(2) CÆSAREA, on the shores of the Mediterranean, about 55 miles N.W. from Jerusalem, enlarged and beautified by Herod the Great, and named in honour of Cæsar Augustus; the place where St. Paul was imprisoned two years (Acts xxiii.—xxv.).—(3) The capital of Cappadocia in Asia Minor.

**Cæsa'rean Operation**, a surgical operation, which consists in delivering a child by means of an incision made through the walls of the abdomen and womb: necessary when the obstacles to delivery are so great as to leave no other alternative. It is said to be so named because Julius Cæsar was brought into the world in this way.

**Cæsa'rion**, son of Julius Cæsar and Cleopatra, put to death by order of Augustus.

**Cæsium**, a rare metal, first discovered by Bunsen and Kirchoff by spectrum analysis in 1860; symbol Cs, atomic weight 133. It is soft, and of a silver-white colour. It is always found in connection with rubidium. It belongs to the same group of elements with lithium, sodium, potassium, and rubidium, viz. the group of the alkali-metals.

**Cæs'tus**, the boxing-glove of the Grecian and Roman pugilists. It was loaded with metal to increase the weight of the blow.

**Cæsu'ra** (L., a cutting), in Latin verse the separation of the last syllable of any word from those which precede it, by making it part of the following foot. In English poetry it is equivalent to a pause.

**Caf**, or KAF, in Mohammedan myth., a mountain, which environs the whole earth as a hedge incloses a field. Its foundation is the stone Sakhral, which is an emerald, whose reflection gives the sky its tints.

**Caffa**, STRAIT OF. See *Yenikale*.

**Caff'eine**, or THE'INE, the active principle of tea and coffee, a slightly bitter, highly azotized substance, crystallizing in slender, silk-like needles, found in coffee-beans, tea-leaves, Paraguay tea, guarana, &c. Coffee contains from 0·8 to 3·6, and tea from 2 to 4 per cent. Doses of 2 to 10 grains induce violent nervous and vascular excitement.

**Caffraria**. See *Kaffraria*.

**Caffre-corn**, a variety of millet (*Sorghum vulgäre*).

**Caffres**. See *Kaffirs*.

**Caftan**. See *Kaftan*.

**Cagli** (käl'yē), a town of Central Italy, 13 m. s. of Urbino, with a cathedral which contains a great fresco by the father of Raphael, Giovanni Santi. Pop. 3000.

**Cagliari** (käl'yä-rē), the capital of the island of Sardinia, at the head of a fine bay on the south coast. It is the residence of the viceroy and of an archbishop, and the seat of a university. It has some manufactures, and is the chief emporium of all the Sardinian trade. Its spacious and safe harbour is defended by several forts. Pop. 35,589.

**Cagliari**, PAULO. See *Veronese*, Paul.

**Cagliostro** (käl-yos'trō), COUNT ALESSANDRO (real name *Giuseppe (Joseph) Balsamo*), a celebrated charlatan, born in 1743 at Palermo. He was the son of poor parents, and entered the order of the Brothers of Mercy, where he acquired a knowledge of the elements of chemistry and physic. He left, or had to leave the order, and committed so many crimes in Palermo that he was obliged to abscond. He subsequently formed a connection with Lorenza Feliciani, whose beauty, ability, and want of principle made her a valuable accomplice in his frauds. With her he travelled through many countries, assuming other names besides that of Count Cagliostro, pretending to supernatural powers, and wringing considerable sums from those who became his dupes. In England he established an order of what he called Egyptian Masonry, in which, as *grand kophta*, he pretended to reveal the secrets of futurity, and made many dupes among the higher classes. In Paris he was implicated in the affair of the diamond necklace, which caused so great a scandal in the reign of Louis XVI., and was imprisoned in the Bastille, but escaped by means of his matchless impudence. He afterwards visited England, but met with

little success. In 1789 he revisited Rome, where he busied himself about freemasonry; but being discovered, and committed to the Castle of St. Angelo, he was condemned by a decree of the pope to imprisonment for life as a freemason, an arch-heretic, and a very dangerous foe to religion. He died in prison in 1795.

**Cagots** (kä'gōz), a peculiar race of men inhabiting France, in the Western Pyrenees. In the middle ages they were believed to be cannibals and heretics, and treated with the greatest ignominy. Legally they are now on a level with other Frenchmen, but socially they are still regarded as degraded. The name is probably derived from the Armor. *cacouz*, leprous; the Cagots being supposed to be descended from lepers.

**Cahir** (kā'ër), an inland town, Ireland, county Tipperary, on the Suir, about 10 miles w. by n. of Clonmel, with an old picturesque castle on the summit of a rock. Pop. 2469.

**Cahors** (kä-ōr), a town in Southern France, dep. Lot, on the river Lot, 60 miles north of Toulouse. Under the Romans it was adorned with a temple, theatre, baths, an immense aqueduct, and forum, remains of which are still to be seen. Among the principal edifices are the cathedral, and an episcopal palace, now converted into the prefecture. It was the birthplace of Gambetta. Pop. 12,057.

**Cai'aphas**, a Jew, was the high-priest at the time when the crucifixion took place. He was deposed A.D. 35, and Jonathan, the son of Annas, appointed in his stead.

**Caicos**, CAYOS (kī'kōz, kī'ōz), or THE KEYS (Spanish *cayo*, a rock or islet), one of the island groups comprehended under the general name of the Bahamas, consisting of six islands besides some uninhabited rocks. The largest, called the Great Key, is about 30 miles long. The inhabitants are few in number, and mostly engaged in fishing and the preparation of salt. In 1873 the Turks Islands and the Caicos were united into a commissionership under the governor of Jamaica.

**Cai'man**, or CAY'MAN. See *Alligator*.

**Cain**, the eldest son of Adam and Eve; the first murderer, who slew his brother Abel. For the biblical history of Cain and his descendants see Gen. iv.—vii. A Gnostic sect of the 2d century called *Cainites* held that Cain was the offspring of a superior power and Eve, and Abel of an inferior power—the Jewish God, and that the kill-



ing of Abel symbolized the defeat of the inferior by the superior power.

**Cainozo'ic**, a geological term (from Gr. *kainos*, recent, and *zōē*, life) applied to the latest of the three divisions into which strata have been arranged, with reference to the age of the fossils they include. The *Cainozoic* system embraces the tertiary and post-tertiary systems of British geologists, exhibiting recent forms of life, in contradistinction to the *Mesozoic*, exhibiting inter-

mediate, and the *Palæozoic*, ancient and extinct, forms. It corresponds nearly with what has been called the age of mammals. Written also *Cænozoic*, *Kainozoic*.

**Caique** (kâ-ēk'), a small skiff or rowing boat; especially a light skiff used in the Bosphorus, where it almost monopolizes the boat traffic. It may have from one to ten or twelve rowers. The name is also given to a Levantine vessel of a larger size.

**Ça-ira** (sü ē-râ: 'It [the revolution] shall

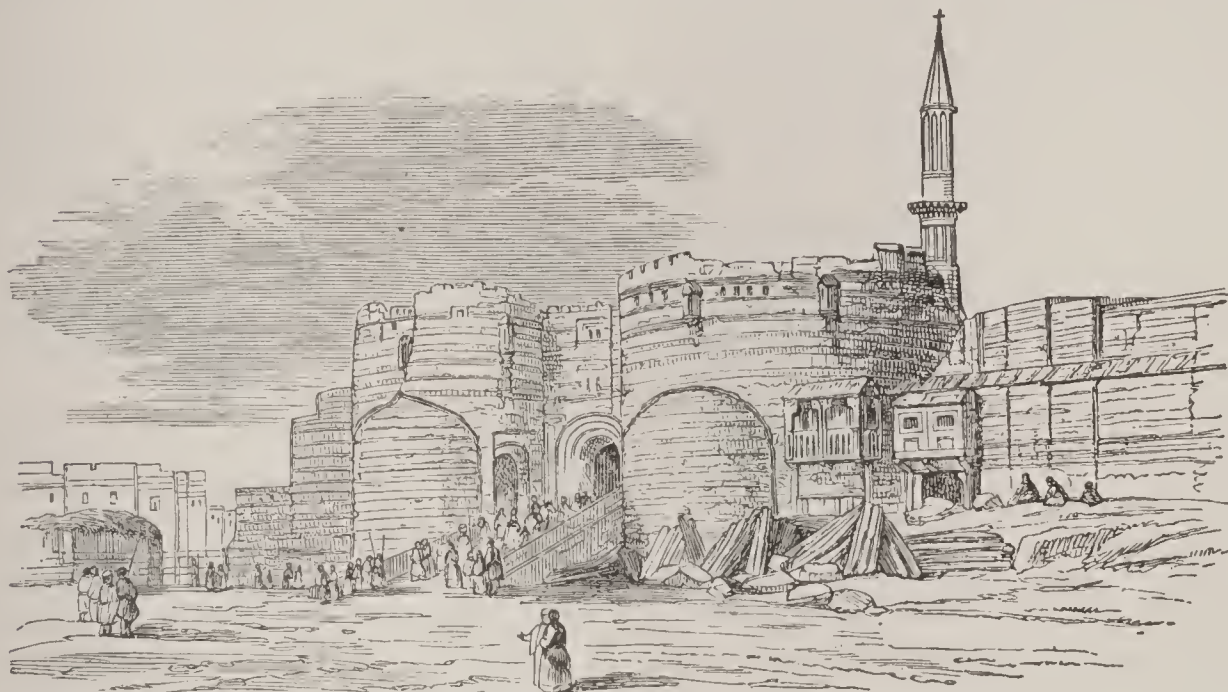

Gateway of the Citadel, Cairo.

go on'), the burden or refrain of a French revolutionary song of 1790. The air was a favourite one with Marie Antoinette.

**Caird**, JOHN, Scottish divine, born 1820, professor of divinity in Glasgow university 1862, principal of the university since 1873. He has published sermons (The Religion of Common Life being the best known), and an Introduction to the Philosophy of Religion (1880).—His brother EDWARD has been professor of moral philosophy at Glasgow since 1866, and has published Account of the Philosophy of Kant; The Social Philosophy and Religion of Comte, and a book on Hegel.

**Cairn** (kārū), a heap of stones; especially one of those large heaps of stones common in Great Britain, particularly in Scotland and Wales, and generally of a conical form. They are of various sizes, and were probably constructed for different objects. Some are evidently sepulchral, containing urns, stone chests, bones, &c. Some were erected to commemorate some great event, others ap-

pear to have been intended for religious rites, while the modern cairn is generally set up as a landmark.

**Cairnes** (keruz), JOHN ELLIOT, political economist, born at Drogheda 1824, died 1875. He was successively professor of political economy in Dublin, Galway, and London. Chief works, Character and Logical Method of Political Economy; Political Essays; Leading Principles of Political Economy, &c.

**Cairngorm**, a Scottish mountain forming one of a great group of the Grampians on the borders of Aberdeen, Banff, and Inverness shires, and rising to the height of 4084 feet above sea-level. It is particularly celebrated for the brownish or yellowish quartz crystals found on it, called *cairngorms*. They are regular hexagonal crystals, with a pyramidal top, and are much used for brooches, seals, and other ornaments.

**Cairo** (kī'rō; Arab. *Kahira*, the Victorious), the capital of Modern Egypt, is situated on the right bank of the Nile, 12 miles above the apex of its delta, and 150 miles by rail

from Alexandria. The character of the town is still mainly Arabic, though in modern times the European style in architecture and other matters has become more and more prevalent. The city is partly surrounded by a fortified wall, and is intersected by seven or eight great streets, from which run a labyrinth of narrow crooked streets and lanes. There are several large squares or places, the principal being the Ezbekiyeh. To the south-east of the town is the citadel, on the last spur of the Mokattam Hills, overlooking the city. It contains the fine mosque of Mohammed Ali, a well 270 feet deep called Joseph's Well, cut in the rock, the palace of the viceroy, &c. There are upwards of 400 mosques. The finest is that of Sultan Hassan. There are also some forty Christian churches, Jewish synagogues, &c. The tombs in the burying-grounds outside the city also deserve mention, especially those known as the tombs of the Caliphs. The trade of Cairo is large, and the bazaars and markets are numerous. Of these the Khan el Khalili, in the north-east of the town, consists of a series of covered streets and courts in which all kinds of eastern merchandise are displayed in open stalls. Cairo has railway communication with Alexandria, Suez, and Siout. It was occupied by the British, Sept. 1882. Pop. 374,838.

**Cairo** (kā'ro), a river-port of the United States, in Illinois, at the junction of the Ohio and Mississippi. Pop. 10,324.

**Cais'son.** In civil engin. (*a*) a vessel in the form of a boat used as a flood-gate in docks. (*b*) An apparatus on which vessels may be raised and floated; especially a kind of floating-dock, which may be sunk and floated under a vessel's keel, used for docking vessels while at their moorings, without removing stores or masts. (*c*) A watertight box or casing used in founding and building structures in water too deep for the coffer-dam, such as piers of bridges, quays, &c.

**Caith'ness**, a county occupying the extreme north-east of the mainland of Scotland; area, 438,878 acres, of which about a fourth is under crop. The surface is generally moory and bare; it is watered by numerous small streams. The coast is rocky, and remarkable for bays and promontories, including among the latter, Dunnet-head, Duncansby-head, and Noss-head. Fishing, together with the rearing of sheep and cattle, forms the principal employment of

the inhabitants. Flagstones (Caithness flags) for pavement are extensively quarried. The towns are Wick, the county town, and Thurso. Caithness gives the title of earl to the head of the Sinclair family. It returns one member to Parliament. Pop. 1891, 37,161.

**Caius** (kēz), KEY, or KAYE, DR. JOHN, English physician, born at Norwich in 1510, died 1573. He was successively first physician to Edward VI., Mary, and Elizabeth. Having obtained permission to erect Gonville Hall, at Cambridge, into the college which still bears his name (Gonville and Caius College), he accepted the mastership and retired from public life, when he appears to have assiduously devoted himself to literary labours connected with his profession.

**Caivano** (kī-vä'nō), a town of S. Italy, about 9 m. north of Naples. Pop. 10,832.

**Cajamarca** (kā-hä-mär'kä). See *Caxamarca*.

**Caj'eput**, or CAJUPUT, the name of several trees, genus *Melaleuca*, order Myrtaceæ, natives of the East Indies and Australia. See next article.

**Caj'eput Oil**, the volatile oil obtained from the leaves of the cajeput-tree (*Melaleuca Cajuputi*), a native of the Indian Archipelago, and some parts of Australia, or from others of the same genus. It is used in medicine as a carminative, stimulant, sudorific, and antispasmodic; also externally in chronic rheumatism, and has been used as a cure for cholera.

**Caj'etan** (or ka'ye-tan), THOMAS DA VIO, CARDINAL, born 1469, died 1534, takes his name of Cajetan from the Italian town of Gaeta, in which he was born. When only fifteen years of age he became a Dominican monk, and in 1508 general of his order. In 1517 he was made a cardinal by Leo X., who, in the following year, sent him as his legate into Germany, the principal object of his mission being to endeavour to bring Luther back to the old faith. He was author of a Commentary on the Bible; a Commentary on the Summa of Thomas Aquinas; a Treatise on the Authority of the Pope, &c.

**Caj'uput.** Same as *Cajeput*.

**Cal'aba-oil**, an excellent illuminating oil obtained from *calaba-nuts*, the seeds of *Calophyllum calaba*, a tree that flourishes in Brazil and the W. Indies.

**Calabar'**, a maritime district of West Africa on the Bight of Biafra, intersected

by two rivers, called respectively Old and New Calabar, under British protection. A large portion of the population are employed in the palm-oil trade. Old Calabar or Bongo river is situated about 90 miles nearly due w. from New Calabar river, with a wide estuary opening into the Bight of Biafra. New Calabar enters the Bight of Biafra at lon. 7° 7' E., and is believed to be one of the numerous terminating branches of the Niger. Duke Town and Creek Town, the chief towns on Old Calabar river, are stations of British missionaries.

**Calabar Bean**, the seed of *Physostigma venenosum*, a leguminous African plant, nearly allied to the kidney-bean. It is a powerful narcotic poison, operating also as a purgative and emetic, and in virtue of these last qualities is the famous 'ordeal bean' of Africa, administered to persons suspected of witchcraft. If it causes purging it indicates crime; if vomiting, innocence. It induces fainting fits and asphyxia, and weakens or paralyzes the action of the heart. It is employed in medicine, chiefly (externally) as an agent for producing contraction of the pupil of the eye in certain cases; sometimes also (internally) in neuralgia, tetanus, and rheumatism.

**Cal'abash**, a vessel made of a dried gourd-shell or of a calabash shell, used in some parts of America and Africa. They are so close-grained and hard that when they contain any liquid they may be put several times on the fire as kettles.

**Calabash-tree**, the popular name of the American trees or shrubs belonging to the genus *Urescentia*, given to them because of their large gourd-like fruits, the hard shells of which are made into numerous domestic utensils, as basins, cups, spoons, bottles, &c. The name is also given to *Adansonia digitata*, the baobab of Africa.

**Calabozo** (-bō'thō), a town of Venezuela, in a plain between the rivers Guarico and Urituco. The neighbouring ponds abound in electrical eels. Pop. 6000.

**Cala'bria**, a name anciently given to the peninsula at the south-eastern extremity of Italy, but now applied to the s.w. peninsula in which Italy terminates, from about lat. 40° N. to the Strait of Messina; area 6663 square miles; pop. 1,304,980. It is divided into three provinces—Cosenza, Reggio, and Catanzaro. The central region is occupied by the great Apennine ridge, to which whole colonies with their cattle migrate in the summer. The flats near the coast are

marshy and unhealthy, but the valleys at the foot of the mountains are rich with the most luxuriant vegetation. The country is subject to earthquakes. Wheat, rice, saffron, anise, liquorice, madder, flax, hemp, olives, almonds, and cotton are raised in abundance. The sugar-cane also comes to perfection here. Sheep, horned cattle, and horses are numerous. Silkworms are extensively raised. The minerals include alabaster, marble, gypsum, alum, chalk, rock-salt, lapis-lazuli, &c. The fisheries are valuable.

**Cala'dium**, a genus of plants, order Araceæ, natives of tropical S. America, often cultivated in hothouses on account of their large finely coloured leaves.

**Calahorra** (kā-lā-or'ra; anc. *Calagurris*), a town of Spain, near the s. side of the Ebro, province of Logroño. Birthplace of Quintilian. Wine, grain, oil, and flax are produced in the neighbourhood. Pop. 8134.

**Calais** (kā-lā), a fortified seaport town of France, dep. Pas-de-Calais, on the Strait of, and 25 miles s.e. of Dover, and distant 184 miles by rail from Paris. The Old Town or Calais proper has a citadel, and was till recently surrounded by fortifications; but the modern suburb of St. Pierre les Calais having been amalgamated with Calais proper, both are now surrounded with forts and other works, to which morasses lend additional strength. Extensive harbour improvements have recently been carried out. Calais has considerable exports of grain, wine, and spirits, eggs, fruit and vegetables; but the town derives its principal importance from its being the chief landing-place for English travellers to the Continent. It has important manufactures of cotton and silk bobbin-net lace. In 1347 Calais was taken by Edward III. of England, after a siege of eleven months. In 1558 it was retaken by the Duke of Guise, being the last relic of the French dominions of the Plantagenets, which at one time comprehended the half of France. Pop. 1891, 56,867.

**Calais**, a town of the U. States in Maine, on the river St. Croix, a centre of the lumber trade. Pop. 1890, 7290.

**Calais**, STRAITS OF. See *Dover, Straits of*.

**Cal'aite**, a name for turquoise.

**Calaman'co**, a glossy woollen stuff chequered in the warp, and either ribbed or plain.

**Calaman'der Wood** (supposed to be a corruption of *Coromandel wood*), a beautiful species of wood, the product of *Diospyros*

*quæsita*, nat. order Ebenaceæ, a native of Ceylon. It resembles rosewood, but is so hard that it is worked with great difficulty. It takes a very high polish, and is wrought into chairs and tables, and yields veneers of almost unequalled beauty.

**Cal'amary**, the general name for two-gilled decapod cuttle-fishes of the family Teuthidæ, but properly used to designate those of the genus *Loligo*. The body is oblong, soft, fleshy, tapering, and flanked behind by two triangular fins, and contains a pen-shaped gladius or internal horny flexible shell. They have the power of discharging, when alarmed or pursued, a black fluid from an ink-bag. The species are found in all seas, and furnish food to dolphins, whales, &c. Some species can dash out of the water and propel themselves through the air for 80 or 100 yards. *Loligo vulgâris* occasionally grows to the length of 2½ feet. Called also *Squid*.

**Cal'ambac**, a fragrant wood, same as *Agila* or *Agallochum*.

**Calamianes** (-â'nez), a cluster of islands in the Indian Sea, among the Philippines, midway between Mindora and Palawan, forming a Spanish province. One of them is 36 miles long and 17 miles broad.

**Cal'amine**, an ore of zinc. See *Zinc*.

**Cal'amint**, a plant of the genus *Calamintha*, nat. order Labiatae. The plants are herbs or shrubs with dense whorls of purple-white or yellow flowers, with a two-lipped corolla and four conniving stamens. Some species are known respectively by the names of mountain-balm, catmint, basil-balm, and wild-basil. The first, also termed common calamint (*C. officinâlis*), has aromatic leaves, employed to make herb-tea.

**Cal'amite** (*Calamîtes*), a genus of fossil plants, very characteristic of the carboniferous rocks. They had the habit of the modern equisetums, to which they are closely allied, but they were arborescent, with woody stems, true leaves, and corms with fruit scales like equisetum, but protected externally with bract leaves.

**Cal'amus**, a genus of palms, the stems of the different species of which are the rattan-canes of commerce. The genus holds a middle station between the grasses and palms, with the habit of the former and the inflorescence of the latter. The species are principally found in the hotter parts of the East Indies.

**Cal'amus**, in Scrip. the word used to translate a Hebrew term which is believed to

mean an aromatic substance obtained from some kind of reed or cane, probably *Andropogon Schœnanthus* or *A. Calamus aromaticus* (sweet-scented lemon-grass). The name is also given to the root of the sweet-flag or sweet rush (*Acörus Calamus*). See *Sweet-flag*.

**Cal'amy**, EDMUND, a Presbyterian divine, born in London in 1600, died 1666. He engaged warmly in the religious disputes of the day, and was one of the writers of the famous treatise against Episcopacy, entitled *Smectymnus*, a title furnished from the initial letters of the authors' names.—His son, Dr. BENJAMIN CALAMY, became an Episcopal clergyman, and distinguished himself by the publication of *A Discourse about a Scrupulous Conscience*, 1683.—The nephew of Benjamin, EDMUND CALAMY, born in 1671, died 1732, has a place in literature as the biographer of Nonconformity. He published an abridgment of Baxter's *History of his Life and Times*, with a continuation; the *Life of Increase Mather*, &c.

**Calas** (kä-lä), JEAN, a memorable victim of fanaticism, born 1698, executed 1762. He was a Protestant, and was engaged as a merchant in Toulouse, when his eldest son committed suicide; and as he was known to be attached to the Roman Catholic faith, a cry arose that he had on that account been murdered by his father. Jean Calas and his whole family were arrested, and a prosecution instituted against him, in support of which numerous witnesses came forward. The parliament of Toulouse condemned him, by eight voices against five, to be tortured and then broken on the wheel, which sentence was carried out, his property being also confiscated. Voltaire became acquainted with his family, and procured a revision of the trial, when Calas was declared innocent, and his widow pensioned.

**Calatafi'mi**, a town of Sicily near its western extremity, with a ruinous Saracenic castle. Near it is the scene of Garibaldi's first victory over the Neapolitans in 1860. Pop. 10,349.

**Calatayud'**, a town, Spain, in the province of Saragossa, on the Jalon. Manufactures: linen and hempen fabrics, ropes, soap, paper, &c. The poet Martial was born here. Pop. 11,512.

**Calatra'va**, anciently a famous fortress of Spain, on the Guadiana, not far from Ciudad-Real. It gave its name to a Spanish order of chivalry founded by Sancho III. in connection with the defence of the place

against the Moors, 1158. For a long period the war with the Moors was carried on mainly by the knights of Calatrava, who acquired great riches. In 1808 their possessions were confiscated, and the order became a simple order of merit.

**Calca'reous**, a term applied to substances partaking of the nature of lime, or containing quantities of lime. Thus we speak of calcareous waters, calcareous rocks, calcareous soils.—*Calcareous spar*, crystallized carbonate of lime. It is found crystallized in more than 700 different forms, all having for their primitive form an obtuse rhomboid. The rarest and most beautiful crystals are found in Derbyshire.—*Calcareous tufa*, an alluvial deposit of carbonate of lime, formed generally by springs, which, issuing through limestone strata, hold in solution a portion of calcareous earth; this they deposit on coming in contact with air and light. Calc-sinter is a variety of it.

**Calceola'ria** (L. *calceolus*, a slipper, from the shape of the inflated corolla resembling a shoe or slipper), slipperwort, a genus of ornamental herbaceous or shrubby plants, nat. order Scrophulariaceæ. All the species are South American; extensively cultivated in our gardens. Most of them have yellow flowers, some have puce-coloured ones, and some occur with the two colours intermixed, while some are white. The greater number in cultivation are hybrids and not true species.



Calceolaria.

**Calcination**, the operation of roasting a substance or subjecting it to heat, generally with the purpose of driving off some volatile ingredient, and so rendering the substance suitable for further operations. The term was formerly also applied to the operation of converting a metal into an oxide or metallic calx: now called *oxidation*.

**Cal'cite**, a term applied to various minerals all of which are modifications of the rhombohedral form of carbonate of calcium. It includes limestone, all the white and most of the coloured marbles, chalk, Iceland-spar, &c.

**Cal'cium**, the metallic base of lime; in the

metallic state, one of the rarest of substances; combined, one of the most abundant and most widely distributed. As phosphate, it forms the main part of the mineral matter of the bones of animals; as carbonate, chalk, limestone, or marble, it forms mountain ranges; as sulphate or gypsum, large deposits in various geological formations; it is a constituent of many minerals, as fluor-spar, Iceland-spar, &c., and is found in all soils, in the ash of plants, dissolved in seawater, and in springs, both common and mineral. It was first obtained in the metallic state by Sir H. Davy in 1808. When quite pure, it is a pale-yellow metal, with a high lustre. It is about one and a half times as heavy as water, ductile, malleable, and very oxidizable. Its salts are for the most part insoluble or sparingly soluble in water, but dissolve in dilute acids. Symbol Ca; atomic weight 40.

**Calc-sinter**, a carbonate of lime, the substance which forms the stalactites and stalagmites that beautify many caves.

**Calculating Machines**, machines or contrivances by which the results of arithmetical operations may be obtained mechanically. Various machines of this kind have been produced, but the only one much used is the invention of M. Thomas of Colmar (the arithmometer), which performs only addition and subtraction along with multiplication and division. The more complicated ones invented for more difficult operations by Babbage were never completed.

**Cal'culus**, THE INFINITESIMAL, or TRANSCENDENTAL ANALYSIS, a branch of mathematical science. The lower or common analysis contains the rules necessary to calculate quantities of any definite magnitude whatever. But quantities are sometimes considered as varying in magnitude, or as having arrived at a given state of magnitude by successive variations. This gives rise to the higher analysis, which is of the greatest use in the physico-mathematical sciences. Two objects are here proposed: First, to descend from quantities to their elements. The method of effecting this is called the *differential calculus*. Second, to ascend from the elements of quantities to the quantities themselves. This method is called the *integral calculus*. Both of these methods are included under the general name *infinitesimal or transcendental analysis*. Those quantities which retain the same value are called *constant*; those whose values are varying are called *variable*. When vari-

able quantities are so connected that the value of one of them is determined by the value ascribed to the others, that variable quantity is said to be a *function* of the others. A quantity is *infinitely great* or *infinitely small*, with regard to another, when it is not possible to assign any quantity sufficiently large or sufficiently small to express the ratio of the two. When we consider a variable quantity as increasing by infinitely small degrees, if we wish to know the value of those increments, the most natural mode is to determine the value of this quantity for any given period, as a second of time, and the value of the same for the period immediately following. This difference is called the *differential* of the quantity. The *integral calculus*, as has been already stated, is the reverse of the *differential calculus*. There is no variable quantity expressed algebraically, of which we cannot find the differential; but there are differential quantities which we cannot integrate: some because they could not have resulted from *differentiation*; others because means have not yet been discovered of integrating them. Newton was the first discoverer of the principles of the infinitesimal calculus, having pointed them out in a treatise written before 1669, but not published till many years after. Leibnitz, meanwhile, made the same discovery, and published it before Newton, with a much better notation, which is now universally adopted.

**Calculus**, in pathology, a general term for the various inorganic concretions which are sometimes formed in the body. Such are *biliary calculi* or gall-stones, formed in the gall bladder; *urinary calculi*, formed by a morbid deposition from the urine in the kidney or bladder; and various others known as *salivary*, *arthritic*, *pancreatic*, *lachrymal*, &c. Urinary and biliary calculi are the most common. The former, when the particles are comparatively small in size, are known as *gravel*, when larger as *stone*. Either cause painful and dangerous symptoms. Stone in the bladder is often operated on by means of lithotomy or lithotrity (which see).

**Calcutta** (*Kâli Ghattah*, the ghaut or landing-place of the goddess Kâli), capital of British India and of Bengal; situated about 80 miles from the sea, on the left bank of the Hooghly (Húglí), a branch of the Ganges, navigable up to the city for large vessels. The river opposite the city varies in breadth from about two furlongs

to three-quarters of a mile. The city extends along the bank for about four miles and a half, and with a breadth of about a mile and a half, the entire site of Calcutta proper being about 8 sq. miles. Adjacent to the city itself, however, are extensive suburbs, which include the large town of Howrah on the opposite side of the Hooghly, connected with Calcutta by a pontoon bridge. The houses of the south or British quarter of Calcutta are of brick, elegantly built, and many of them like palaces, in striking contrast with the northern quarter occupied by the natives, the *Pettah* or *black town*, which has narrow, crooked, and ill-built streets. The city is encompassed by a spacious way called the Circular Road. On the west side is an extensive quay about 2 miles long, called the Strand. Outside the city, between the river and the fashionable quarter, lies Fort William, a magnificent octagonal work, which cost altogether £2,000,000 sterling, mounts over 600 guns, contains 80,000 stand of arms, and will hold 15,000 men. The plain between Fort William and the city forms a favourite promenade. At the north side, called the Esplanade, stands the government house, or palace of the governor-general, built by the Marquis Wellesley, at an expense of £1,000,000 sterling. Other edifices worth notice are the town-hall, supreme court, government treasury, writers' buildings, Metcalfe Hall, mint, theatre, medical college, general post-office, general hospital, the new cathedral, the old cathedral. A tolerably good supply of filtered water from the Hooghly is furnished to the inhabitants; and a complete system of drainage has been constructed. Calcutta has an extensive system of internal navigation through the numerous arms and tributaries of the Ganges, and it almost monopolizes the external commerce of Bengal. There is a railway from Calcutta to Delhi, with branches to Ranigunge, Agra, &c., and through Allahabad to Bombay. Another line extends to Dacca. There is telegraphic communication with all parts of India, and with Europe. The principal exports are opium, cotton, rice, wheat, jute, gunny-bags, tea, indigo, seeds, raw silk, &c. Of the imports the most important in respect of value are cotton goods. Salt is a considerable import. The maritime trade is of the annual value of fully £70,000,000; the inland trade is as large or larger. The native shops are in bazaars in the narrow streets of the native

CALDARA — CALDERON DE LA BARCA.

town, the principal being the Burra, and the Old and New China Bazaars. The religious, educational, and benevolent institutions of Calcutta are numerous, the leading British, American, and European missions being represented. The educational institutions comprise the Presidency College, the Mohammedan College, and the Sanscrit College, all government colleges, besides others mainly supported by missionary efforts. There is a botanical garden be-

longing to the Asiatic Society on the beautiful island of Garden Reach, the summer residence of the rich British, and there are also extensive botanic gardens on the west bank of the river connected with the agricultural and horticultural societies. At the end of the 17th century Calcutta was only a cluster of three mud villages; in 1891 it contained, with its suburbs, a population of 861,764.

Caldara, **POLIDORO**, called also *Caravaggio*



Calcutta. — Bazaar on the Chitpore Road.

*gio*, an Italian painter, born in 1495 at Caravaggio, in the Milanese. In his youth he carried bricks for the masons in the Vatican, and envying the artists at work there devoted himself to painting under the guidance of Maturino. He was afterwards employed by Raphael on the friezes of the Vatican. The oil painting of Christ on the way to Calvary is his most noteworthy picture. In 1543 he was murdered by his domestic.

**Caldas** (from *L. calidæ aquæ*, warm waters), a name of various places with warm springs in Spain, Portugal, and S. America.

**Cal'decott**, **RANDOLPH**, artist, born at Chester, 1846. He entered a bank, but gave up banking for art. His first success was the publication, in 1875, of his illustrations of a volume of selections from Washington Irving's *Sketch-book*, under the title of *Old Christmas*. It was followed by his illustrations of *Bracebridge Hall* (1876), of *Mrs. Carr's North Italian Folk* (1877), of *Black-*

*burn's Breton Folk* (1879), of *Æsop's Fables with Modern Instances* (1883). His most popular work, however, was the series of coloured children's books commenced by him in 1878, and including *John Gilpin*, the *Elegy on the Death of a Mad Dog*, and the *Great Panjandrum*. He died at St. Augustine, Florida, in 1886.

**Calde'ra**, a seaport, Chili, 50 miles N.W. of Copiapó, an outlet for the produce of the copper mines in the interior. Pop. 3230.

**Calderon' de la Barca**, **DON PEDRO**, the great Spanish dramatist, born at Madrid, 1600; educated in the Jesuits' College, Madrid, and at Salamanca. Before his fourteenth year he had written his third play. Leaving Salamanca in 1625, he entered the army and served with distinction for ten years in Milan and the Netherlands. In 1636 he was recalled by Philip IV., who gave him the direction of the court entertainments. The next year he

was made knight of the order of Santiago, and he served in 1640 in the campaign in Catalonia. In 1651 he entered the clerical profession, and in 1653 obtained a chaplain's office in the archiepiscopal church at Toledo. But as this situation removed him too far from court, he received, in 1663, another at the king's court chapel (being still allowed to hold the former); and at the same time a pension was assigned him from the Sicilian revenue. His fame greatly increased his income, as he was solicited by the principal cities of Spain to compose their *autos sacramentales*, for which he was liberally paid, and on which he specially prided himself. Besides heroic comedies and historical plays, some of which merit the name of tragedies, Calderon has left ninety-five *autos sacramentales*, 200 *loas* (preludes), and 100 *saynetes* (farces). He wrote his last play in the eightieth year of his age. His smaller poems are now forgotten; but his plays have maintained their place on the stage even more than those of Lope de Vega. Their number amounts to 128. He wrote, however, many more, some of which were never published. He died May 25, 1681.

**Cal'derwood**, DAVID, Scottish divine and ecclesiastical historian, born 1575, and in 1604 ordained minister of Crailing, Roxburghshire, where he distinguished himself by his opposition to the introduction of prelacy. In 1617 he was banished for contumacy, and went to Holland. In 1625 he returned to Scotland, and in 1640 became minister of the church of Pencaitland, near Edinburgh. He then engaged in writing the *History of the Church of Scotland*, a work published in 1842-49 by the Wodrow Society. He died in 1650.

**Caledo'nia**, CALEDONIANS, the names by which the northern portion of Scotland and its inhabitants first became known to the Romans, when in the year 80 Agricola occupied the country up to the line of the Firths of Clyde and Forth. He defeated the Caledonians in 83, and again at Mons Grampius in 84, a battle of which a detailed description is given by Tacitus. In the early part of the 3d century they maintained a brave resistance to Severus, but the name then lost its historic importance. Caledonia is now used as a poetical name of Scotland.

**Caledonian Canal**, a water-way passing through Glenmore or the Great Glen of Scotland, and allowing vessels of 500 or 600

tons to sail from the Moray Firth to Loch Eil and the sea on the west. The route passes through Lochs Ness, Oich, and Lochy, the whole distance from sea to sea being about 60 miles, of which only 22 consist of canal proper. There are twenty-seven locks, the highest being about 95 feet above the sea. It cost £1,350,000, and has never been a paying concern.

**Cal'endar** (L. *calendarium*, from *calendæ*, the first day of the month), a record or marking out of time as systematically divided into years, months, weeks, and days. The periodical occurrence of certain natural phenomena gave rise to the first division of time, the division into weeks being the only purely arbitrary partition. The year of the ancient Egyptians was based on the changes of the seasons alone, without reference to the lunar month, and contained 365 days divided into twelve months of thirty days each, with five supplementary days at the end of the year. The Jewish year consisted of lunar months of which they reckoned twelve in the year, intercalating a thirteenth when necessary to maintain the correspondence of the particular months with the regular recurrence of the seasons. The Greeks in the earliest period also reckoned by lunar and intercalary months, but after one or two changes adopted the plan of Meton and Euctemon, who took account of the fact that in a period of nineteen years, the new moons return upon the same days of the year as before. This period of nineteen years was found, however, to be about six hours too long, and subsequent calculators still failed to make the beginning of the seasons return on the same fixed day of the year. Each month was divided into three decads. The Romans at first divided the year into ten months, but they early adopted the Greek method of lunar and intercalary months, making the lunar year consist of 354, and afterwards of 355 days, leaving ten or eleven days and a fraction to be supplied by the intercalary division. This arrangement continued till the time of Cæsar. The first day of the month was called the *calends*. In March, May, July, and October the 15th, in other months the 13th, was called the *ides*. The ninth day before the *ides* (reckoning inclusive) was called the *nones*, being therefore either the 7th or the 5th of the month. From the inaccuracy of the Roman method of reckoning the calendar came to represent the vernal equinox nearly two months after



the event, and at the request of Julius Cæsar, the Greek astronomer Sosigenes, with the assistance of Marcus Fabius, contrived the so-called *Julian calendar*. The chief improvement consisted in restoring the equinox to its proper place by inserting two months between November and December, so that the year 707 (B.C. 46), called the *year of confusion*, contained fourteen months. In the number of days the Greek computation was adopted, which made it  $365\frac{1}{4}$ . To dispose of the quarter of a day it was determined to intercalate a day every fourth year between the 23d and 24th of February. This calendar continued in use among the Romans until the fall of the empire, and throughout Christendom till 1582.

By this time, owing to the cumulative error of eleven minutes, the vernal equinox really took place ten days earlier than its date in the calendar, and accordingly Pope Gregory XIII. issued a brief abolishing the Julian calendar in all Catholic countries, and introducing in its stead the one now in use, the *Gregorian or reformed calendar*. In this way began the *new style*, as opposed to the other or *old style*. Ten days were to be dropped; every hundredth year, which by the old style was to have been a leap year, was now to be a common year, the fourth excepted; and the length of the solar year was taken to be 365 days, five hours, forty-nine minutes, and twelve seconds, the difference between which and subsequent observations is immaterial. The new calendar was adopted in Spain, Portugal, and France in 1582; in Catholic Switzerland, Germany and the Netherlands in 1583; in Poland in 1586; in Hungary in 1587; in Protestant Germany, Holland, and Denmark in 1700; in Switzerland in 1701; in England in 1752; and in Sweden, 1753. In the English calendar of 1752, also, the 1st of January was now adopted as the beginning of the legal year, and it was customary for some time to give two dates for the period intervening between 1st January and 25th March, that of the old and that of the new year, as January 1752. Russia alone retains the old style, which now differs twelve days from the new.

In France, during the revolution, a new calendar was introduced by a decree of the National Convention, Nov. 24, 1793. The time from which the new reckoning was to commence was the autumnal equinox of 1792, which fell upon the 22d of September, when the first decree of the new republic had been promulgated. The year was made

to consist of twelve months of three *decades* each, and, to complete the full number, five *fête* days, or *sansculotides* (in leap years six) were added to the end of the year. The seasons and months were as follows:— Autumn; 22d Sept. to 22d Dec.: *Vendémiaire*, vintage month; *Brumaire*, foggy month; *Frimaire*, sleet month. Winter; 22d Dec. to 22d March: *Nivôse*, snowy month; *Pluviôse*, rainy month; *Ventôse*, windy month. Spring; 22d March to 22d June: *Germinal*, bud month; *Floréal*, flower month; *Prairial*, meadow month. Summer; 22d June to 22d Sept.: *Messidor*, harvest month; *Thermidor*, hot month; *Fructidor*, fruit month. The common Christian or Gregorian calendar was re-established in France on the 1st January, 1806, by Napoleon. For the Mohammedan calendar, see *Hegira*.

**Cal'ender**, a machine consisting of two or more cylinders (calenders) revolving so nearly in contact with each other that cloth or paper passed between them is smoothed and glazed by their pressure, or some other kind of finish is imparted to the surface.

**Cal'enders**, a sect of dervishes in Turkey and Persia. They preach in the market places, and live upon alms. Their name is derived from their founder.

**Cal'ends** (L. *calendæ*), the first day of the month among the Romans. See *Calendar*. — *The Greek calends*, a time that never occurred; an ancient Roman phrase which originated in the fact that the Greeks had nothing corresponding to the Roman calends.

**Calen'dula**, the marigold genus of plants.

**Cal'enture**, a kind of delirium sometimes caused within the tropics, especially on board ship, by exposure to excessive heat. It is said that the sufferer imagines the sea to be a green field, in which he is tempted to walk by the coolness and freshness of its appearance. The term is nearly obsolete.

**Cal'gary**, a rising town on the Canadian Pacific Railway, near the eastern base of the Rocky Mountains, in the district of Alberta, the centre of an important cattle and horse-ranching district. Pop. 1600.

**Calhoun** (kal-hön'), JOHN CALDWELL, an American statesman, born in 1782, died 1850. He was admitted to the bar of S. Carolina in 1807, and in 1811 was sent to Congress, where he distinguished himself by his eloquence. In 1817 he was made secretary of war under President Monroe; in 1824 he was elected vice-president of the United States; in 1832, a senator; in 1844,

secretary of state, and in 1845, again a senator. He continued till his death an advocate of extreme state rights, and of the policy of the slave-holding states.

**Cali** (kā'lē), a town of S. America, Colombia, state of Cauca, with a good trade. Pop. 12,743.

**Calibre**, a technical term for the diameter of the bore of a firearm.

**Calico** (from *Calicut* in India), a general term for any plain white cotton cloth: in America it is usually applied to printed cottons.

**Calico-printing** is the art of applying colours to cloth after it has come from the hand of the weaver in such a manner as to form patterns or figures. This art, originally brought from India, is sometimes practised on linen, woollen, and silk, but most frequently upon that species of cotton cloth called calico. The process was first introduced into Britain in 1738, and was originally accomplished by means of hand-blocks made of wood on which patterns or parts of patterns for each different colour were cut. These blocks were of various dimensions, according to the nature of the work, and where several colours were employed in one pattern, a block for each colour was necessary. As an improvement in the method of printing from wooden blocks, especially where delicacy of outline is required, engraved copper-plates were introduced about 1760; but the greatest improvement was effected by the introduction of cylinder printing about 1785, which has almost superseded the other methods, except for particular styles. The machinery now generally used consists of various modifications of the cylinder printing-machine, in which a number of separate engraved cylinders are mounted, corresponding to the number of colours to be printed. Formerly the cloth had to pass once through the machine for every colour; but now, by an arrangement of machinery equally ingenious and effective, any number of cylinders are fitted on one machine, which act on the cloth one after the other, and by this means the pattern is finished with a corresponding number of colours in the same time that was formerly employed to give one. A great variety of methods are employed in calico-printing, but they all fall under the general heads of *dye-colours* and *steam-colours*. Under the first head are included all the styles in which the pattern is printed on the cloth by a mordant—a substance which may have little or no colour itself, but has an

affinity for the fibre on the one hand, and for the colouring matter on the other—the dye or colouring matter being subsequently fixed by dyeing on such parts of the cloth as have been impregnated with the mordant, and thus bringing out the pattern. In steam-colour printing the colouring material is applied to the cloth direct from the printing-cylinder, and subsequently fixed by steaming. In steam-colours there is no limit to the number and variety of shades which may be produced, each colour-box on the cylinder printing-machine containing the whole ingredients essential to the production and fixation of a separate and distinct shade of colour. This process is superseding most of the other styles, the brilliant coal-tar colours so extensively used being almost entirely fixed by steaming. The bodies used for fixing are tin mordants, tannic acid, &c., which are mixed with the dye-colours and printed together. The effects of calico-printing are varied by numerous other operations, such as the *discharge-style*, in which the cloth is first dyed all over, then printed in a certain pattern with discharge-chemicals, which either produce a pattern of some other colour, or one purely white, as in the Turkey-red bandanna handkerchiefs. The *resist-style*, in some respects, is the reverse of the discharge-style; the process being to print a pattern in certain chemicals, which will enable those parts to resist the action of the dye subsequently applied to all other parts of the cloth. After the prints have undergone the printing process they are submitted to a series of finishing operations, the object of which is to give to the fabrics a pleasing appearance to the eye.

**Calicut**, a seaport of India, presidency of Madras, on the Malabar coast, which was ceded to the British in 1792. It was the first port in India visited by Europeans, the Portuguese adventurer, Pedro da Covilham having landed here about 1486, and Vasco da Gama in 1498. It has considerable trade, and manufactures cotton cloth, to which it has given the name *calico*. Pop. 57,085.

**Calif and Califate.** See *Caliph*.

**Califor'nia**, one of the United States of America, on the Pacific Ocean; area, 158,360 square miles. The coast extends the full length of the state, measuring about 700 miles, following the indentations. On the s. part of the coast are a few islands. The state may be divided into three distinct portions—the central being much the

## CALIFORNIA.

most densely populated. This central portion is embraced between the parallels  $35^{\circ}$  and  $40^{\circ}$ , and has on its E. side the Sierra Nevada, and on its w. the Coast Ranges. Between these two mountain chains lies the Great Central Valley of the Sacramento and San Joaquin, renowned for its beauty and fertility. It is this valley, which is about 450 miles in length by about 40 in breadth, to which the state now owes its principal wealth, and which has made it famous for its wheat, its wool, its fruits (including sub-tropical fruits in the s.), and the produce of its vineyards. N. of the parallel of  $40^{\circ}$ , where the Coast Ranges and the Sierra unite, the country is extremely rough and thinly inhabited. That portion of the state which lies to the s. and E. of the southern junction of the Coast Ranges and the Sierra is also thinly inhabited, with the exception of a narrow strip along the coast. The principal river is the Sacramento, which flows s. for upwards of 300 miles, receiving numerous affluents from the Sierra Nevada, and falls into the Bay of Suisun. The San Joaquin rises in the Sierra Nevada, flows N. for about 250 miles, and joins the Sacramento about 15 miles above Suisun Bay. It receives the waters of lake Tulé or Tulares, and has numerous tributaries. The Bay of San Francisco, forming the most capacious harbour on the Pacific coast, is about 60 miles in length, 14 broad, and with a coast-line of 275 miles. It is connected with the ocean by a strait about 2 miles wide, and from 5 to 7 long, called the Golden Gate. The city of San Francisco stands on the N.W. shore of the southern arm.

The peaks of the Sierra Nevada—Mount Shasta, Lassen's Butte, Spanish Peak, Pyramid Peak, Mounts Dana, Lyell, Brewer, Tyndall, Whitney, and others—reach from 10,000 to nearly 15,000 feet above the sea (Mount Whitney is 14,886). The volcanic character of the state is manifested by the mountain formations; and earthquakes are frequent. California is celebrated for its many wonderful natural objects and remarkable scenery. Noteworthy are the Yosemite Valley (which see) and the 'big tree groves,' containing groups of giant red-wood trees—*Sequoia gigantēa*—some of which reach the height of nearly 400 feet.

The mineral resources of California are of great importance. Gold is found in abundance, the quantity obtained in 1888 being valued at 12,750,000 dols. It was

first discovered in 1848, and brought a great rush of settlers to this part of the world. Among other minerals found in the state are silver, quicksilver, copper, coal, lead, tin, antimony, cobalt, &c.

California, being intersected by the isothermal line of  $60^{\circ}$ , has the same mean annual temperature as the north of Spain and the centre of Italy, and may, generally speaking, be esteemed genial and mild. The year may be divided into a dry and a wet season. On the lower slopes of the Sierra Nevada the climate is said to be that of constant spring. Wheat, barley, oats, maize and other cereals, the root-crops and vegetables of temperate climates are very largely grown. Fruits are most varied, including olives, grapes, apples, pears, plums, figs, oranges, peaches, pomegranates, plantains, bananas, and cocoa-nuts; the indigo-plant also, and the sugar-cane and tobacco, yield abundant returns. The cultivation of the vine is rapidly extending, and the production of wine and brandy and raisins is large and increasing. Irrigation is practised in many localities.

The principal town and port is San Francisco; the capital is Sacramento. Of the other towns the most important are Oakland and Los Angeles. The extensive foreign export trade, consisting chiefly in wheat, flour, wool, wine, &c., is carried on almost exclusively at San Francisco; but the state also sends eastwards large quantities of produce by rail, including raisins and dried fruits, honey, timber, furs, &c. Much of the foreign trade is with Britain, China, and Japan. The most important railroad is the Central Pacific, extending from San Francisco to Ogden, Utah, where it joins the Union Pacific Railway. Ocean steamers run regularly between San Francisco and Australia, Panama, Mexico, China, and Japan.

California (a much larger area than the present state) was ceded by Mexico to the United States in 1847, and in 1850 was admitted into the Union. The state senate consists of 40, and the assembly of 80 members. It elects 6 members to Congress. Education is well provided for. The state university is at Berkeley, near Oakland. The pop. in 1860 was 379,994; in 1880, 864,694, including over 16,000 Indians and 75,025 Chinese. Total 1890, 1,208,130.

**California**, GULF OF, a gulf on the w. coast of North America, in Mexico, lying between the peninsula of Lower California

and the mainland. It is about 700 miles long, and, through most of its length, is less than 100 miles wide. It has long had a pearl fishery.

**California**, LOWER, a territory of Mexico, comprising a peninsula jutting into the Pacific Ocean, and separated from the mainland throughout its entire length by the Gulf of California. It is nearly 800 miles in length, and in different places 30, 60, 90, and 120 miles wide; area 61,562 sq. miles. It is largely mountainous and arid, but is said to possess valuable agricultural and mineral resources. The chief towns are Loretto and La Paz, the capital. Population 30,198, of whom perhaps a half are Indians.

**Calig'ula**, CAIUS CÆSAR AUGUSTUS GERMANICUS, Roman emperor, son of Germanicus and Agrippina, was born A.D. 12, in the camp at Antium; assassinated by conspirators A.D. 41. He received from the soldiers the



Caligula.

surname of Caligula, on account of his wearing the *caligæ*, a kind of boots in use among them. He succeeded Tiberius, A.D. 37, and made himself very popular by his mildness and ostentatious generosity; but at the end of eight months he was seized with a disorder, caused by his irregular mode of living, which appears to have permanently deranged his intellect. After his recovery, he suddenly showed himself the most cruel and unnatural of tyrants—a monster of debauchery and prodigality, a perpetrator of the greatest crimes and follies. The most exquisite tortures inflicted on the innocent served him for enjoyments. In the madness of his arrogance he even considered himself a god, and

caused sacrifices to be offered to himself. One of his greatest follies was the building of a bridge between Baiæ and Puteoli (Puzzuoli), in order that he might be able to boast of marching over the sea on dry land. He projected expeditions to Gaul, Germany and Britain, and having reached the sea, he bade his soldiers gather shells for spoils, and then led them back to Rome. At last a band of conspirators put an end to his career in the 29th year of his age.

**Cal'iper Compasses**, compasses made either with arched legs to measure the diameters of cylinders or globular bodies, or with straight legs and retracted points to measure the interior diameter or bore of anything.

**Cal'iph**, CALIF, or KHALIF (*vicegerent*) is the name assumed by the successors of Mohammed in the government of the faithful and in the high-priesthood. *Caliphate* is therefore the name given to the empire of these princes which the Arabs founded in Asia, and enlarged, within a few centuries, to a dominion exceeding even the Roman empire in extent. The appellation of caliph has long ago been swallowed up in *Shah*, *Sultan*, *Emir*, and other titles peculiar to the East. Mohammed having died without naming his successor, three rival parties appeared immediately after his death. The first was headed by Omar, a kinsman of the prophet, who demanded the election of Abu Bekr, Mohammed's father-in-law. The second party was headed by Ali, the husband of Fatima, the prophet's daughter, who declared for himself. The third party consisted of people of Medina, who demanded the election of one of themselves. Abu Bekr was chosen (A.D. 632), and prosecuting the conquest of Syria, he defeated the Byzantine emperor Heraclius and took Damascus. His successor, Omar, completed the conquest of Syria, took Jerusalem, subjugated Egypt, and defeated the Persians. He is said to have erected over 1500 mosques. He was succeeded by Othman, or Osman, who completed the conquest of Persia and other Eastern countries, extended his dominion in Africa, and took Cyprus and Rhodes. Othman was succeeded by Ali, who is regarded as the first legitimate possessor of the dignity by a numerous sect of Mohammedans, which gives him and his son, Hassan, almost equal honour with the prophet. During his reign a great schism divided the Mohammedans into two sects called the Sunnites and the Shiites,

the former acknowledging the authority of all the caliphs, the latter acknowledging only Ali and his descendants. Ali was murdered in A. D. 660, and his son Hassan in 661, when Moawiyah, the founder of the dynasty of the Ommiyades, became caliph, and transferred his capital from Medina to Damascus. His army continued the conquest of Northern Africa, and twice unsuccessfully attacked Constantinople. Carthage was taken in 698, after which the Mohammedans encountered no serious opposition in Northern Africa. From the union of the Arabic and Berber races of Africa sprung the Moors of Saracenic history. The conquest of Spain immediately followed, Tarik, the lieutenant of the Saracen general, Musa, having totally defeated the King of the Goths. The caliphate now extended from the Oxus and Indus to the Atlantic. In 732 a great host of Moslem soldiery crossed the Pyrenees and invaded France, but were totally defeated at Tours by Charles Martel. In 755 the Mohammedan dominion split up into the *Eastern* and *Western Caliphates*, the western caliph having Spain, with his capital at Cordova; and the eastern including Northern Africa, with the capital at Bagdad. The former was ruled by a series of Ommiyade caliphs; the latter by the dynasty of the Abbasides. The most celebrated of the Abbaside caliphs of Bagdad was Haroun al Rashid (Aaron the Just), 786-808, under whom learning, science, and art were in a flourishing state. Subsequently the Moslem kingdom lost province after province, and the temporal authority of the caliph of Bagdad was destroyed. Numerous independent dynasties were set up, the most important of which was that of the Fatimites, founded by an African Saracen who claimed descent from Fatima the daughter of the prophet. This dynasty conquered Sicily and several parts of Italy, Egypt, and Palestine. It came to an end in 1171. In 1031 the Western Caliphate ceased, and the Saracenic dominions in Spain was broken up into several small states. The most brilliant period of the Western Caliphate was in the 9th and 10th centuries, when literature, science, and art were in more flourishing condition than anywhere else in Europe. The Eastern Caliphate lingered on till 1258, when Bagdad was taken and sacked by the Mongols.

**Calisa'ya Bark**, a variety of Peruvian or cinchona bark, namely, that of *Cinchona calisaya* or *flava*.

**Calisthen'ics**, a less correct spelling of *Callisthenics*.

**Cal'iver**, an early form of hand-gun, musket, or arquebuse, lighter and shorter than the musket, which had the advantage of the latter in being fired without a rest, and much more rapidly. It seems to have gone out of fashion about 1630.

**Calix'tines**, or UTRAQUISTS, a sect of Hussites in Bohemia, who published their confession in 1421, the leading article of which was a demand to partake of the cup (*calix*) as well as of the bread in the Lord's Supper, from which they received their name of *Utraquists* (L. *uterque*, both). Their tenets were conceded by the articles of Basel in 1433, and they became the predominant party in Bohemia. The name Calixtine is also given to a follower of Georg Calixtus.

**Calix'tus**, the name of three popes.—CALIXTUS I. was a Roman bishop from 217 to 224, when he suffered martyrdom. CALIXTUS II. was elected in 1119, in the monastery of Clugny, successor of the expelled pope, Gelasius II., who had been driven from Italy by the Emperor Henry V., and had died in this monastery. He excommunicated the Emperor Henry V. on account of a dispute respecting the right of investiture; as also the anti-pope Gregory VIII., whom he drove from Rome. He availed himself of the troubles of the emperor to force him, in 1122, to agree to the Concordat of Worms. He died in 1124.—CALIXTUS III., chosen in 1168 in Rome, as anti-pope to Paschal III., and confirmed by the Emperor Frederick I., in 1178, was obliged to submit to Pope Alexander III. As he was not counted among the legal popes, a subsequent pope, ALFONSO BORGIA, made pope in 1455, was called *Calixtus III.* He died in 1458.

**Calixtus** (properly *Callisen*), GEORG, an able and enlightened German theologian of the Lutheran Church in the 17th century, was born in 1586 in Schleswig, died 1656. In 1614 he became professor of theology in Helmstedt. He wrote against the celibacy of the clergy, and proposed a reunion of Catholics and Protestants upon the basis of the Apostle's creed.

**Call**, a term used in various senses; as, (1) in reference to joint-stock companies, and the like, a demand for payment of the whole or a portion of the amount which a person has undertaken to contribute to any scheme; (2) in Presbyterian churches, the

written document signed by the members of a congregation calling on or inviting a clergyman to become their pastor, and presented to him after he has been duly elected. —*Call to the bar*, the formal admission of a person to the rank of barrister.

**Calla**, a genus of plants, nat. order *Orontiaceæ*. The known species are few and of widely different habitats. *C. palustris* occurs in the north of Europe and America. It has a creeping root-stock extremely acrid in taste, but which, when deprived of its causticity by maceration and boiling, is made by the Lapps into bread. The beautiful *Richardia ethiopica* (Ethiopian lily) was formerly included in this genus, and is still sometimes called *Calla ethiopica*.

**Callao** (kál-yä'ō), a seaport town of Peru, the port of Lima, from which it is 6 miles distant, and with which it is connected by a railway; pop. 33,502. The roadstead is one of the best in the Pacific, and there is a dock, with an area of nearly 52 acres, constructed at a cost of £1,700,000, besides a floating iron dock. Callao is the emporium of the whole of the trade of Peru, importing manufactured goods, and exporting guano, copper ore, cubic nitre, wool, bark, &c. In 1746 the old town was destroyed by an earthquake, with much loss of life and damage to shipping.

**Callcott**, JOHN WALL, an eminent composer, born at Kensington in 1766, died 1821. He studied under Handel; obtained the Mus. Doc. degree from Oxford; was author of a musical grammar; and was especially noted for his glee compositions. —SIR AUGUSTUS WALL, brother of the above, born at Kensington in 1779, died 1844. He studied portrait-painting under Hoppner, but distinguished himself specially in landscape-painting. In 1837 he was knighted, and in 1843 was appointed keeper of the royal collections of pictures.

**Call'ernish**, a village and district of Scotland, Isle of Lewis, 16 miles west of Stornoway, famous for its circles of standing-stones. The main circle is 40 feet in diameter, formed of twelve unhewn blocks of gneiss from 10 to 13 feet high, with a larger block in the centre. From this circle rows of stones project to the east, west, and south. There are upwards of 40 blocks altogether.

**Callichthys** (-ik'this), a genus of fishes belonging to the abdominal malacopterygians, and family Siluridæ or sheat-fishes. They are natives of hot climates, and are

said to make their way over land in search of water during dry seasons.

**Callig'onum**, a genus of shrubs belonging to the *Polygonaceæ*. The best-known species is *C. pallasia*, of the steppes near the Caspian, the acid fruit and shoots of which are often eaten to allay thirst.

**Callim'achus**. 1. A Greek poet and grammarian, born at Cyrene, in Libya, of a noble family; flourished about 250 B.C. He taught at Alexandria, and was appointed by Ptolemy Philadelphus librarian of the Alexandrine Museum. He wrote an epic poem called *Galatea*, several prose works, and tragedies, elegies, comedies, &c., but only some seventy-two epigrams and six hymns remain.—2. A Greek architect and artist, flourished about 400 B.C., the reputed originator of the Corinthian column.

**Call'inger**. See *Kalinjar*.

**Calli'nus**, of Ephesus, the earliest Greek elegiac poet, flourished about 730 B.C. Only a few fragments of his elegies are extant.

**Calliope** (kal-i'ō-pē), one of the Muses. She presided over eloquence and heroic poetry and was the mother of Orpheus.

**Calliope**, an organ of pipes through which steam passes with great velocity, a tune being thus played by a key-board attached thereto.

**Callis'thenes** (-ēz), a Greek philosopher and historian, a native of Olynthus, was appointed to attend Alexander in his expedition against Persia. His expressed disapprobation of the conduct of Alexander incurred the displeasure of the courtiers and royal favourites, and he was put to death on a pretended charge of treason, 328 B.C.

**Callisthen'ics** (Gr. *kalli-*, beautiful, and *sthenos*, strength), the art or practice of exercising the body for the purpose of giving strength to the muscles and grace to the carriage. The term is usually applied to the physical exercises of females, as gymnastics is to those of males.

**Callos'ity**, any thickened or hardened part of the human skin caused by pressure and friction. Also the natural cutaneous thickenings on the buttocks of monkeys.

**Callot** (kál-ō), JACQUES, a French engraver, born about 1593, died in 1635. He distinguished himself in Italy and France, and was patronized by the Grand-duke of Tuscany and by Louis XIII. He preferred etching, probably because his active and fertile genius could in that way express itself more rapidly. In the space of twenty years he designed and executed about 1600 pieces,

the characteristics of which are freedom, variety, and naïveté.

**Callu'na.** See *Heath*.

**Cal'lus**, a callosity; also a new growth of osseous matter between the extremities of fractured bones, serving to unite them.

**Cal'mar**, the principal city of a province of the same name in Sweden, is situated opposite to Oeland, on the island of Quarnholm, and has some manufactures and a good trade. It derives celebrity from the treaty of 1397, called the Union of Calmar, by which the three Scandinavian kingdoms Denmark, Norway, and Sweden were united under Margaret, hereditary Queen of Denmark, and widow of Haco, King of Norway. Pop. 1892, 11,822.

**Calmet** (kâl-mā), AUGUSTINE, distinguished as an exegetical and historical writer, was born in Lorraine in 1672, died at Paris 1757. He early entered the order of St. Benedict, and became the head of several abbeys in succession. He was an industrious compiler of voluminous works, such as *Commentaire sur tous les Livres de l'Ancien et du Nouveau Testament* (Paris, 1707-16), *Dictionnaire Historique et Critique de la Bible, Histoire Ecclésiastique et Civile de la Lorraine*, &c.

**Calms**, REGIONS OF, tracts in the Atlantic and Pacific Oceans, on the confines of the trade-winds, where calms of long duration prevail. About the winter solstice their average northern limit is in 5° N. lat., and in the months about the summer solstice about 12° N. lat. The southern limit lies nearly always to the north of the equator, varying between 1° and 3° N. lat.

**Calmucks.** See *Kalmucks*.

**Calne** (kän), a municipal and, until 1885, a parliamentary borough in Wiltshire, England, 31 miles N.N.W. of Salisbury. It is the centre of the manufacture of the far-famed Wiltshire bacon. Pop. of mun. bor. 1891, 3495.

**Cal'omel** (HgCl), mercurous chloride; a preparation of mercury much used in medicine, and also found native as horn-quick-silver. It is prepared by grinding in a mortar sulphate of mercury with as much mercury as it already contains, and heating the compound which is formed with common salt in a retort until the mercury sublimes. The calomel is thus produced as a white powder. It is used in a variety of ailments, as a purgative, a vermifuge, &c.

**Calonne** (kâ-lon), CHARLES ALEXANDREDE, a French statesman, born in 1734 at Douai,

died at Paris 1802. He studied at Paris, and devoted himself to the duties of an advocate. In 1783 he succeeded Maurepas as minister of finance; but after four years of incessant endeavours at financial reform he could do nothing but advise an assembly of the notables, which accordingly met in 1787. The financial statement which he then made led to his dismissal, and he retired to England. On the breaking out of the revolution he supported the royalist party with much zeal.

**Calophyl'lum**, a genus of plants, nat. order Guttiferæ, consisting of large timber trees, with shining leaves which have numerous transverse parallel veins. *C. Inophyllum* yields a medical resin, the tacamahac of the East Indies. The seeds afford an oil which is used for burning, for making ointment, &c.

**Calores'cence**, the transmutation of heat rays into light rays; a peculiar transmutation of the invisible calorific rays, observable beyond the red rays of the spectrum of solar and electric light, into visible luminous rays, by passing them through a solution of iodine in bisulphide of carbon, which intercepts the luminous rays and transmits the calorific. The latter, when brought to a focus, produce a heat strong enough to ignite combustible substances, and to heat up metals to incandescence; the less refrangible calorific rays being converted into rays of higher refrangibility, whereby they become luminous.

**Calor'ic**, the name given to a supposed subtle imponderable fluid to which the sensation and phenomena of heat were formerly attributed.—*Caloric engine*, an air-engine (which see).

**Calorim'eter**, an apparatus for measuring absolute quantities of heat or the specific or latent heat of bodies, as an instrument for measuring the heat given out by a body in cooling from the quantity of ice it melts or from the rise of temperature it produces in water around it.

**Calot'ropis**, a genus of shrubs or small trees, order Asclepiadaceæ, one species of which yields the Indian fibre called *mudar* (which see). For another species see *Apple of Sodom*.

**Calotte** (ka lot'), a skull-cap worn by ecclesiastics in Catholic countries, and in England by serjeants-at-law.

**Calot'tists**, or the REGIMENT DE LA CALLOTTE, a society which sprang up at Paris in the last years of the reign of Louis XIV., and was named from the word *calotte* (a

skull-cap worn by the priests), which was the symbol of the society. All were admitted whose ridiculous behaviour, odd character, foolish opinions, &c., had exposed them to public criticism.

**Cal'otype**, the name given to the process, invented by Talbot about 1840, of producing photographs by the action of light upon paper impregnated with nitrate of silver. See *Photography*.

**Caloy'ers** (Gr. *kalos*, beautiful, good, *gerōn*, an old man), Greek monks, belonging to the order of St. Basil, who lead a very austere life. Their most celebrated monastery in Asia is at Mount Sinai; in Europe at Mount Athos. They do not all agree as to their mode of life. Some of them are cenobites; that is, they live in common. Others are anchorites, living alone, or with only one or two companions; and others again are recluses, who live in grottoes or caverns in the greatest retirement, and are supported by alms supplied to them by the monasteries.

**Calpee'**, KALPI, a town, Hindustan, N. W. Provinces, on the right bank of the Jumna, about 50 miles s.s.w. of Cawnpore. During the Sepoy mutiny Calpee became a principal rendezvous of the revolted Gwalior contingent, which was signally defeated, first by Sir Colin Campbell, in the vicinity of Cawnpore, and afterwards at Calpee itself by Sir Hugh Rose, May 26, 1858. Pop. 14,306.

**Calpur'nia**, the fourth wife of Julius Cæsar, married to him 59 B.C. She was a daughter of L. Calpurnius Piso, who was consul in 58 B.C.

**Calpur'nius**, TITUS, a Latin pastoral poet, born in Sicily about the end of the 3d century. Eleven eclogues composed by him are extant.

**Caltabello'ta**, a town of Sicily, province of Girgenti. Pop. 6178.

**Caltagirone** (-jē-rō'nā), a town of Sicily, 34 m. s.w. of Catania: the see of a bishop. It is noted for the manufacture of terracotta figures and pottery. Pop. 28,119.

**Caltanisset'ta**, a town, Sicily, capital of the province of the same name, on the right bank of the Salso, 62 miles s.e. of Palermo. In the vicinity are springs of petroleum and of hydrogen gas, a mud-volcano, and important sulphur mines. Pop. 25,027.—The province has an area of 1445 square miles, with a pop. of 265,930.

**Caltha**, the genus of ranunculaceous plants to which the marsh-marigold (*C. palustris*) belongs.

**Cal'trop**, a military instrument with four iron points disposed in such a manner that three of them being on the ground the other points upward, formerly scattered on the ground to impede the progress of an enemy's cavalry.—Also the common name of *Centaurea Calcitrapa* (the star-thistle), found in waste places in the south of England. The heads are covered with long yellow spines. The water caltrop is *Trapa natans*, the fruit of which has several horns formed of the indurated lobes of the calyx.

**Calum'ba**, or COLOMBO, a plant, *Jateorhiza palmāta*, indigenous to the forests of Mozambique, nat. order Menispermaceæ. The large roots are much used as a bitter tonic in cases of indigestion. American or false calumba is the bitter root of *Frasera Carolinensis*, a gentianaceous herb found in North America.

**Cal'umet**, a kind of pipe used by the American Indians for smoking tobacco. Its bowl is usually of soft red soapstone, and the tube a long reed, ornamented with feathers. The calumet is (or was) used as a symbol or instrument of peace and war. To accept the calumet is to agree to the terms of peace, and to refuse it is to reject them. The calumet of peace is used to seal or ratify contracts and alliances, to receive strangers kindly, and to travel with safety. The calumet of war, differently made, is used to proclaim war.

**Calvados** (kál-và-dos), a French dep., part of the old province of Normandy, bounded on the n. by the English Channel, and e. w. and s. by the deps. Eure, La Manche, and Orne. Area, 2145 sq. m. It is named from a dangerous ridge of rocks which extends along the coast for 10 or 12 miles. The dep. is undulating and picturesque, and possesses rich pastures. Chief town, Caen. Pop. 1891, 428,945.

**Calvaert** (kál-värt'), DIONYS, a painter, was born at Antwerp in 1555, died at Bologna 1619. He went very young to Italy, and ultimately opened a school at Bologna, from which proceeded 137 masters, and among these Albano, Guido, and Domenichino.

**Cal'vary**, from L. *calvaria*, a skull, used in the Vulgate to translate the Hebrew *golgotha* (a skull), and applied to the place outside Jerusalem where Christ was crucified, usually identified with a small eminence on the north side of the city. The term is also applied in Roman Catholic countries to a kind of chapel, sometimes erected on a hill near a city and sometimes



on the exterior of a church, as a place of devotion, in memory of the place where our Saviour suffered; as also to a rocky mound or hill on which three crosses are erected, an adjunct to religious houses.

**Calvert**, GEORGE, the first Baron Baltimore. See *Baltimore*.

**Calvi**, a fortified seaport of France, on the N.W. side of Corsica. It was taken by the English in 1794, but abandoned in the following year. Pop. 2000.

**Calvin**, JOHN (so called from *Calvinus*, the Latinized form of his family name, *Cauvin* or *Chauvin*), reformer and Protestant theological writer, born at Noyon, in Picardy, 1509, died at Geneva 1564. His father, Gerard Cauvin, *procureur-fiscal* and diocesan secretary, dedicated him early to the church, and he was presented with a benefice at the age of twelve. The income derived from this nominal office enabled him to proceed to Paris and enter on a course of regular study. He was soon led to entertain doubts respecting the priesthood, and became dissatisfied with the teaching of the Roman Catholic Church; in consequence he gave up his cure, and took to the study of the law in Orleans. In 1532 he returned to Paris a decided convert to the reformed faith, and was soon compelled to fly, when, after various wanderings, he found a protector in Margaret of Navarre. In 1534 he returned to Paris; but, finding that the persecution against those who were inclined to the doctrines of the reformers was still raging, he retired to Basel in the autumn of the same year. At Basel he completed and published his great work, *The Institutes of the Christian Religion* (*Christianæ Religionis Institutio*; 1536). Having gone to Italy, after a short stay at Ferrara he went to Geneva, where reform had just been established. In 1538, in company with Farel, he was expelled from Geneva in consequence of the reign of extreme strictness they had introduced, when he went first to Berne and then to Strasburg. Here he married a widow, Idelette de Burie, and had one son, who died early. In 1541 his friends in Geneva succeeded in effecting his recall, when he laid before the council the draft of his ordinances respecting church discipline, which were immediately accepted and published. His college of pastors and doctors and his consistorial court of discipline formed a theocracy, with himself at the head of it, which aimed virtually at the management of all municipal matters and the control of

the social and individual life of the people. A magistrate was deposed and condemned to two months' imprisonment 'because his life was irregular, and he was connected with the enemies of Calvin.' James Gruet was beheaded 'because he had written profane letters and obscene verses, and endeavoured to overthrow the ordinances of the church.' Michael Servetus, passing through Geneva in 1553, was arrested, and through Calvin's instrumentality was burnt alive because he had attacked the mystery of the Trinity in a book which was neither written nor printed at Geneva. This has been regarded as the great blot on Calvin's career, though approved of by many others of the reformers. His energy and industry were enormous: he preached almost daily, delivered theological lectures three times a week, attended all deliberations of the consistory, all sittings of the association of ministers, and was the soul of all the councils. He was consulted, too, upon points of law as well as of theology. Besides this, he found time to attend to political affairs in the name of the Republic, to publish a multitude of writings in defence of his opinions, and to maintain a correspondence through all Europe. Up to 1561 the Lutherans and the Calvinists were as one, but in that year the latter expressly rejected the tenth article of the Confession of Augsburg, besides some others, and hence arose the name of *Calvinists*. Calvin retained his personal influence to the last; but a year or two before his death his health had broken down. As a theologian Calvin was equal to any of his contemporaries in profound knowledge, acuteness of mind, and in the art of making good a point in question. As an author he merits great praise. His Latin works are written with much method, dignity, and correctness. He was also a great jurist and an able politician. Besides the *Institutes*, the most important of Calvin's works are the *De Necessitate Reformandæ Ecclesiæ*, *In Novum Testamentum Commentarii*, and *In Librum Geneseos Commentarii*. The collected works of Calvin have been published in English by the Calvin Translation Society of Edinburgh in fifty-two vols. 8vo (1843-55).

**Calvinism**, the theological tenets or doctrines of John Calvin, including a belief in predestination, election, total depravity, original sin, effectual calling, and the final perseverance of the saints. These doctrines were received before Calvin's days, though he is doubtless amongst the most learned and

copious writers in their propagation and defence. The system also includes several other points of controversy, such as that of free-will, the Sonship of the Second Person of the Trinity, and other differences in doctrine as between Calvinists and Arminians. Calvinism is the theological system expounded in the Westminster Confession of Faith, and is therefore the faith officially held by the Presbyterian churches generally; it is also substantially identical with what is known as 'evangelicalism' in any of the churches or religious bodies.

**Calx** (L., lime or chalk), a term formerly applied to the *residuum* of a metal or mineral which has been subjected to violent heat, burning, or calcination.

**Calycan'thus**, a genus of hardy American shrubs, of which one species, Florida allspice (*C. floridus*), has yellow flowers, and is sweet-scented.

**Cal'ydon**, an ancient city of Northern Greece, in Ætolia, celebrated in Greek mythology on account of the ravages of a terrible boar. All the princes of the age assembled at the famous Hunt of the Calydonian Boar, which was finally despatched by Meleager.

**Calym'ene**, a genus of fossil trilobites found in the Silurian rocks.

**Calyp'so**, in Greek mythology, a nymph who inhabited the island Ogygia, on the shores of which Ulysses was shipwrecked. She promised him immortality if he would consent to marry her, but after a seven years' stay she was ordered by Hermes to permit his departure.

**Calyp'tra**, the hood of the theca or capsule of mosses. The same name is given to any hood-like body connected with the organs of fructification in flowering plants.

**Calyptræ'idæ**, a family of gasteropodous molluscs, known as bonnet or chambered limpets. The typical genus *Calyptraea* includes the cup-and-saucer limpet.

**Calystegia**. See *Bind-weed*.

**Calyx**, in botany, the name given to the exterior covering of a flower, that is, the floral envelope consisting of a circle or whorl of leaves external to the corolla, which it incloses and supports. The parts or leaves which belong to it are called *sepals*; they

may be united by their margins, or distinct, and are usually of a green colour and of less delicate texture than the corolla. In many flowers, however (especially monocotyledons), there is little or no difference in character between calyx and corolla, in which case the whole gets the name of *perianth*.

When the calyx leaves are distinct the calyx is called *polysepalous* (*a a a* in accompanying cut); when united, *gamosepalous* or *monosepalous* (*b b*).



Forms of Calyx.

**Cam** or **GRANTA**, an English river which rises in Essex, flows N.E. through Cambridgeshire, and falls into the Ouse after a course of about 40 miles.

**Cam**, in machinery, a simple contrivance for converting a uniform rotatory motion into a varied rectilinear motion, usually a projecting part of a wheel or other revolving piece so placed as to give an alternating or varying motion to another piece that comes in contact with it and is free to move only in a certain direction.

**Camaieu** (ka-mā'ū), monochrome painting or painting with a single colour, varied only by gradations of the single colour, by light and shade, &c. Drawings in Indian-ink, sepia, &c., are classed as works *en camaieu*.

**Camal'dolites**, **CAMALDULIANS**, or **CAMALDUNIANS**, a nearly extinct fraternity of monks founded in the Vale of *Camaldoli* in the Apennines in 1018, by St. Romuald, a Benedictine monk. They were originally hermits, but as their wealth increased they associated in convents. They have always been distinguished for their extreme asceticism, their rules in regard to fasting, silence, and penances being most severe. Like the Benedictines they wear white robes.

**Camargue** (kā-mārg), LA, the delta of the Rhône, in S. France, department of Bouches-du-Rhône. It is protected from the inundations of the river by dikes, and is mostly an unhealthy tract of pools and marshes, only a small portion of it being cultivated.

**Camaryl'la**, a word first used in Spain, but now in other countries also, for a com-



Calyptra.

*a*, Moss. *b*, Capsule with calyptra. *c*, Do. with calyptra removed.

pany of secret counsellors or advisers to a ruler; a cabal; a clique.

**Camayeu.** See *Camaicu*.

**Cambacérés** (kän-bä-sā-rā), JEAN JACQUES RÉGIS DE, Duke of Parma, born in 1753 at Montpellier; died at Paris, 1824. He was trained a lawyer, and by his talents soon attracted the notice of the Convention, and was appointed to various judicial offices. In the discussion relative to the fate of the king he declared Louis guilty, but disputed the right of the Convention to judge him, and voted for his provisory arrest, and in case of a hostile invasion, death. For a time he had the management of foreign affairs; and when Bonaparte was first consul, Cambacérés was chosen second. After the establishment of the empire, Cambacérés was created arch-chancellor, grand officer of the Legion of Honour, and ultimately Duke of Parma. He was banished on the second restoration of Louis XVIII., but was subsequently permitted to return.

**Cam'baluc, Cam'balu**, the name by which the city which we now know as Peking became known to Europe during the middle ages.

**Cam'bay**, a feudatory state in India, Bombay Presidency; lying at the head of the gulf of the same name in the western part of Gujarát. Area 350 sq. m.; pop. 86,074. Also, chief town of above state, situated at the head of the Gulf of Cambay, formerly a flourishing port, but now decayed. Pop. 36,007.—The gulf separates the peninsula of Kathiawar from the northern coast of Bombay, having a length of about 80 miles, and an average breadth of 25 miles.

**Cam'berwell**, a suburb of London, s. side of the Thames, in the county of Surrey. Pop. 235,312. See *London*.

**Cam'berwell Beauty**, a rare British butterfly, *Vanessa Antiöpa*, so named from having been sometimes found at Camberwell when it was more rural than now, and from its great beauty. The wings are deep, rich, velvety brown, with a band of black, containing a row of large blue spots around the brown, and an outer band or margin of pale yellow dappled with black spots. The caterpillar feeds on the willow.

**Cam'bium**, in botany, a mucilaginous viscid substance forming a layer immediately under the liber or inner bark of plants, supposed to fulfil important functions in the formation of new wood. It is only found in exogenous stems.

**Cambo'dia**, or CAMBO'JA, a country in the

Indo-Chinese peninsula, bounded N. by Siam, E. by Anam, s. by French Cochinchina and Gulf of Siam, and w. by Gulf of Siam. The greater part of it is low and flat with numerous streams, the chief being the Mekong. The soil is very fertile, producing large quantities of rice, and the vegetation generally is marked by tropical luxuriance. Cattle are exceedingly numerous; among wild animals are the elephant and tiger; gold and precious stones are found. In early times Cambodia was a powerful state exacting tribute even from Siam, but it gradually fell into decay, and in the last and early in the present century lost a large part of its dominions to Siam. Magnificent ruins, bridges, &c., attest the former prosperity of the country. Since 1863 it has been a protectorate of France, and since 1884 practically a French colony, though nominally ruled by a king of its own. The chief town is Pnom-Penh on an arm of the Mekong; the port is Kampot, on the Gulf of Siam. Pop. estimated at 1,500,000, partly Cambodians proper, partly Siamese, Annamese, &c.

**Cambo'dia**, river. See *Mekong*.

**Cam'borne**, a town and parl. div. of England, county of Cornwall, 11 miles N.W. of Falmouth. Being in the vicinity of productive tin and copper mines, it has risen of late to be a place of some importance. Pop. of urban sanitary district, 14,700.

**Cambrai** (kän-brā; in German called *Kamerik* or *Kambryk*), a fortified French city, on the Scheldt, in the dep. Du Nord, 104 miles north-east of Paris; long celebrated for its manufacture of fine linens and lawns, whence similar fabrics are called *cambrics*. It is the seat of an archbishop, and has a cathedral, an archiepiscopal palace, town-house, &c. Cambrai is the *Camaracum* of the Romans, by whom it was fortified. Pop. 14,483.—The *League of Cambrai*, a league formed in 1508 between Louis XII. of France, the German Emperor Maximilian, and Ferdinand of Spain, for the purpose of humbling the Republic of Venice, and which was joined in 1509 by Pope Julius II.

**Cam'bria**, the Latin name of Wales, derived from Cynri, the name of the branch of the Celts to which the Welsh belong.

**Cambrian Rocks**, in geology, an extensive series of gritstones, sandstones, conglomerates, slates, and shales, lying under the Lower Silurian beds, and above the Archæan, and divided into the Upper and Lower Cambrian. Many fossils occur in the

CAMBRIC — CAMBRIDGE.

series, including sponges, star-fishes, trilobites, brachiopods, lamellibranchs, pteropods, gasteropods, cephalopods, &c. They may be regarded as the bottom rocks of the Silurian system, and are well developed in N. Wales (hence the name), but can be recognized in many other regions.

**Cam'bric**, originally the name of a fine kind of linen which was manufactured principally at Cambrai (German *Kambryk*) in French Flanders, whence the name. It is now applied to a cotton fabric, which is very extensively manufactured in imitation of the true cambric, and which is in reality a kind of muslin.

**Cam'bridge** (kām'brij), an inland county of England, bounded by the counties of Lincoln, Northampton, Huntingdon, Bedford, Hertford, Essex, Suffolk, and Norfolk; area 524,935 acres. The soil is diversified and generally fertile; a large part belongs to the fen country. The principal rivers are the Cam or Granta, and the Ouse. By drainage much of the fen land (including the Bedford Level) has been converted into good arable land and into excellent pastures, and about nine-tenths of the county is under cultivation. The county abounds in dairy farms, celebrated for the production of excellent butter and cheese. The S.E. of the county, extending from Gogmagog Hills to Newmarket, being bare and heathy, is chiefly appropriated to sheep; on the S. the ground produces fine wheat, barley, and oats. This county returns three members to Parliament. The county town is Cambridge; other towns are Ely, Wisbech, Newmarket, and March. Pop. 188,862.—CAMBRIDGE, the county town, is situated on the river Cam, 50 miles N. of London. It is an ancient place, and was a Roman station (Granta). It occupies a perfect level encompassed by the colleges, and their beautiful grounds and gardens, on both sides of the Cam. Several of the streets are narrow and winding, but some are spacious and airy, and much improvement has taken place of late years. The town is supported mainly by the presence of the university; but has some manufactures. It sends one member to Parliament. Pop. 1891, 36,983.

**Cambridge, UNIVERSITY OF**, one of the two great English universities, as old at least as the thirteenth century, situated in the above town. The following list contains the names of the colleges or distinct corporate bodies comprised in the university, with the time when each was founded:—

1. St. Peter's College, or Peter House .....	1257
2. Clare College, formerly Clare Hall.....	1326
3. Pembroke College.....	1347
4. Gonville and Caius College.....	1348
5. Trinity Hall .....	1350
6. Corpus Christi College .....	1352
7. King's College .....	1441
8. Queen's College.....	1448
9. St. Catherine's College, or Catherine Hall ...	1473
10. Jesus College.....	1496
11. Christ's College.....	1505
12. St. John's College .....	1511
13. Magdalene College .....	1519
14. Trinity College.....	1546
15. Emmanuel College.....	1584
16. Sidney Sussex College .....	1598
17. Downing College .....	1800
18. Cavendish College.....	1873
19. Selwyn College.....	1882
20. Ayerst Hall (or Hostel) .....	1884

Each of these colleges is a separate corporation, which is governed by laws and usages of its own, although subject to the paramount laws of the university. At the head of each is an official who is generally styled the Master of the college. Next in rank come the Fellows (in number about 400), who are graduates and have formerly been distinguished students, and who receive an annual allowance from the college funds, varying from about £150 to £250. The students (undergraduates) are of several classes, namely: *Fellow-commoners*, who are generally the younger sons of the nobility, or young men of fortune, pay high fees, and have the privilege of dining at the fellows' table; *scholars*, who are elected by examination or otherwise, and receive an annual allowance from the college funds; *pensioners*, who form the great body of the students and pay ordinary fees; *sizar*s, students of limited means, who receive various emoluments. There is also a certain number of non-collegiate students. The head of each college and the fellows together form the governing body of the college. The university is composed of a chancellor, vice-chancellor, the masters or heads of colleges, fellows of colleges, and students, and is incorporated as a society for the study of all the liberal arts and sciences. The senate, which is composed of all who have taken the degree of Doctor or Master, is the great legislative assembly of the university. The chief executive power is vested in the chancellor, the high-steward, and the vice-chancellor, who is the head of some college. Two proctors superintend the discipline of all persons *in statu pupillari*. There are three terms: Michaelmas, or October term, which lasts from the 1st of October to the 19th of December; Lent, or January term, which begins on the 8th of January and lasts till within a few days of Easter; and Easter,

or Midsummer term, beginning three weeks after the end of the Lent term, and ending on the 24th of June. Every student must have completed nine terms' residence during three-fourths of each term before he can take the degree of B.A., LL.B., M.B., or B.C., for which, accordingly, a residence of three years is required. The degree of M.A. is obtained four years after that of B.A. without examination. Bachelors of Arts may obtain 'honours' in the following departments—Mathematics, Classics, Moral Sciences, Natural Sciences, Law, History, Theology, Semitic Languages, Indian Languages, Mediæval and Modern Languages. The successful candidates in each of these departments are arranged in a *tripos*, that is, in three grades. In the mathematical tripos these three grades are called respectively Wranglers, Senior Optimes, and Junior Optimes; in the other triposes they are called first, second, and third class. The other degrees conferred by the university are those of Doctor and Bachelor of Divinity, Doctor of Law and of Medicine, and Doctor and Bachelor of Music. Women who have fulfilled the conditions of residence and standing may be admitted to the tripos examinations. Those who pass are placed in the published lists, and receive certificates; but no degrees are conferred upon them. Two colleges (Girton and Newnham) have been established for women, but they are no part of the university, though many of the university lectures are open to students of these colleges. The annual income of the university was recently about £30,000, arising from various sources, including the produce of fees at matriculations, for degrees, &c. The number of undergraduate students is about 3000. There are over forty professors in the various departments. A botanic garden, an anatomical school, an observatory, and a valuable library containing more than 300,000 printed volumes, besides many manuscripts, are attached to the university. The new museums and laboratories for the study of science are among the most complete in the country. The university sends two members to the House of Commons. The right of election is vested in the members of the senate.

**Cambridge**, a city of Massachusetts, U.S., separated from Boston by Charles River. It is well laid out, with fine broad streets and avenues, and many open spaces adorned with shrubs and trees. The most important institution it contains is Harvard University

(which see). Though distinct from Boston it really forms part of it. Pop. 70,028.

**Cambusken'neth**, an ancient abbey of Scotland, now in ruins, near Stirling, founded in 1147 by David I.

**Cambuslang'**, a town of Scotland  $3\frac{3}{4}$  miles S.E. of Glasgow, with collieries adjacent. Pop. 9090.

**Camby'ses**, (1) a Persian of noble blood, to whom King Astyages gave his daughter Mandane in marriage. Astyages was dethroned by Cyrus, the offspring of this union. (2) The son of Cyrus the Great, and grandson of the preceding, became, after the death of his father, King of the Persians and Medes, B.C. 529. In the fifth year of his reign he invaded Egypt, conquering the whole kingdom within six months. But his expeditions against the Ammonites and Ethiopians having failed, his violent and vindictive nature broke out in cruel treatment of his subjects, his brother Smerdis and his own wife being among his victims. He died in 521 B.C.

**Camden**, WILLIAM, a celebrated antiquary and historian, was born in London in 1551. Appointed second master of Westminster School, he devoted all his leisure to the study of British antiquities, and began to collect matter for his great work, the *Britannia*, which gives a topographical and historical account of the British Isles from the earliest ages. In 1586 the first edition was published, and procured the author a high reputation. Later editions were considerably enlarged and improved. In 1593 Camden became head master of Westminster, and four years afterwards Clarencieux king-at-arms. Besides the *Britannia*, Camden published a narrative of the Gunpowder Plot and a history of the reign of Queen Elizabeth (*Annales Rerum Anglicarum regnante Elizabetha*), and an account of the monuments and inscriptions in Westminster Abbey. He died Nov. 9, 1623, at Chiselhurst in Kent, in the house which was afterwards that of Napoleon III.

**Camden**, a city of New Jersey, U. States. It is on the left bank of the Delaware, and connected with Philadelphia, on the opposite side, by a steamboat service. There are manufactories of various kinds, foundries, saw-mills, &c. Pop. 1890, 58,313.

**Camel** (*Camelus*), a genus of ruminant quadrupeds, characterized by the absence of horns; the possession of incisive, canine, and molar teeth; a fissure in the upper lip; a long and arched neck; one or two humps or

## CAMEL — CAMELFORD.

protuberances on the back; a broad elastic foot ending in two small hoofs, which does not sink readily in the sand of the desert. The native country of the camel is said to extend from Marocco to China, within a zone of 900 or 1000 miles in breadth. The common camel (*Camēlus Bactriānus*), having two humps, is only found in the northern part of this region, and exclusively from the ancient Bactria, now Turkestan, to China. The dromedary, or single-hump camel (*Camēlus dromedarius*, or Arabian camel), is

found throughout the entire length of this zone, on its southern side, as far as Africa and India. The Bactrian species is the larger, more robust, and more fitted for carrying heavy burdens. The dromedary has been called the race-horse of its species. To people residing in the vicinity of the great deserts the camel is an invaluable mode of conveyance. It will travel three days under a load and five days under a rider without drinking. The stronger varieties carry from 700 to 1000 lbs. burden. The camel's power



Figs. 1 and 2, Arabian Camels and Camel-driver. Fig. 3, Bactrian or two-humped Camel.

of enduring thirst is partly due to the peculiar structure of its stomach, to which are attached little pouches or water-cells, capable of straining off and storing up water for future use, when journeying across the desert. It can live on little food, and of the coarsest kind, leaves of trees, nettles, shrubs, twigs, &c. In this it is helped by the fact that its humps are mere accumulations of fat (the back-bone of the animal being quite straight) and form a store upon which the system can draw when the outside supply is defective. Hence the camel-driver who is about to start on a journey takes care to see that the humps of his animal present a full and healthy appearance. Camels which carry heavy burdens will do about 25 miles a day, those which are used for speed alone, from 60 to 90 miles a day. The camel is rather passive than docile, showing less intelligent co-operation with its master than the horse or elephant; but it is very vindictive when injured. It lives from forty to fifty years. Its flesh is esteemed by the

Arab and its milk is his common food. The hair of the camel serves in the East for making cloth for tents, carpets and wearing apparel. It is imported into European countries for the manufacture of fine pencils for painting and for other purposes. The South American members of the family Camelidæ constitute the genus *Auchenia*, to which the llama and alpaca belong; they have no humps.

Camel, a water-tight box or caisson used to raise a sunken vessel, or to float a vessel over a shoal or bar. It is let down with water in it, and is attached to the vessel, after which the water is pumped out, and the camel rises from its buoyancy.

Camelford, a village, and, previous to 1832, a parliamentary borough of England (with two members), county of Cornwall, on the Camel, 28 miles n.w. Plymouth. Camelford is the Camelot of Arthurian romance, and four miles to the n.w. of Camelford are the ruins of King Arthur's castle of Tintagel.

**Camellia** (ka-mēl'ya), a genus of plants, order Ternstrœmiaceæ (the tea order), with showy flowers and elegant dark-green, shining, laurel-like leaves, nearly allied to the plants which yield tea, and named from George Joseph Kamel, a Moravian Jesuit. The *C. japonica*, in Japan and China, is a lofty tree of beautiful proportions. It is the origin of many double varieties of our gardens. Besides this species, the *C. Sasanqua*, with small white scentless flowers, and the *C. reticulata* (net-veined), with its large peony-like flowers, are cultivated in U. S.

**Camel'opard**, a name given to the giraffe (*Camelopardälis giraffa*), originally from the notion that it was a kind of hybrid between a camel and leopard. It constitutes the only species of its genus and family (Camelopardalidæ or Devexa). See *Giraffe*.

**Camel's Thorn** (genus *Alhagi*), a name of several plants belonging to the natural order Leguminosæ, and the sub-order Papilionaceæ. They are herbaceous or half-shrubby plants growing in the deserts of Egypt and the East, and derive their name from the fact that they afford a food relished by camels. Some of the species yield a manna-like exudation from the leaves and branches.

**Cam'eo**, a general name for all gems cut in relief, in contradistinction to those hollowed out, or *intaglios*. More particularly, a cameo is a gem composed of several different-coloured layers having a subject in relief cut upon one or more of the upper layers, an under layer of a different colour forming the ground. For this purpose the ancients used the onyx, sardonyx, agate, &c. The shells of various molluscs are now much used for making cameos; and they are also imitated on glass.

**Cam'era Lu'cida** (L., 'clear chamber'), an optical instrument employed to facilitate the sketching of objects from nature by producing a reflected picture of them upon paper. Wollaston's apparatus is one of the commonest. The essential part is a totally-reflecting prism with four angles, one of which is  $90^\circ$ , the opposite one  $135'$ , and the other two each  $67^\circ 30'$ . One of the two faces which contain the right angle is turned towards the object to be sketched. Rays falling in a straight line on this face, as from *f*, are totally reflected at *g* from the face *cb* to the next face at *h*, whence they are again totally reflected to the fourth face, from which they emerge in a straight line. An eye (*e*) placed so as to receive the emergent rays,

will see an image of the object in the direction *m*, and by placing the sketching paper below in this place, the image may be traced with a pencil. As the paper, for conve-

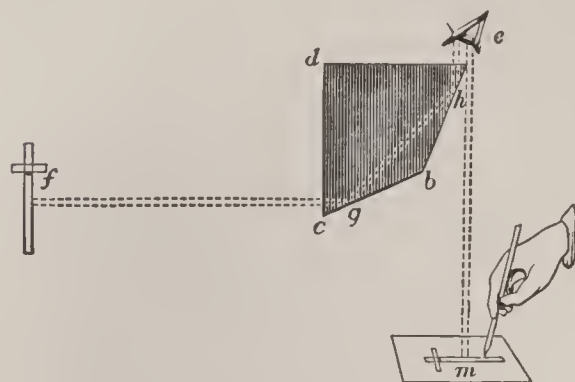

Camera Lucida.

nience of drawing, must be at a distance of about a foot, a concave lens, with a focal length of something less than a foot, is placed close in front of the prism in drawing distant objects. By raising or lowering the prism in its stand, the image of the object to be sketched may be made to coincide with the plane of the paper. The prism is mounted in such a way that it can be rotated either about a horizontal or a vertical axis; and its top is usually covered with a movable plate of blackened metal, having a semicircular notch at one edge, for the observer to look through. This form of camera has undergone various modifications. It is very convenient on account of its portability.

**Cam'era Obscu'ra** (L., 'dark chamber'), an optical instrument employed for exhibiting the images of objects in their forms and colours, so that they may be traced and a picture drawn, or may be represented by photography. A simple camera obscura is presented by a darkened chamber into which no light is permitted to enter excepting by a small hole in the window-shutter. A picture of the objects opposite the hole will then be seen on the wall, or on a white screen placed opposite the opening. A simple camera obscura is shown in the figure; the rays of light passing through a convex lens at *A*, being reflected from the mirror *M* (which is at a slope of  $45^\circ$ ) to the glass plate *N*, where they form an image that may be traced. Another arrangement is a kind of tent surrounded by opaque curtains, and having at its top a revolving lantern, containing a lens with its axis horizontal, and a mirror placed behind it at a slope of  $45^\circ$ , to reflect the transmitted light down,

wards on the paper. It is still better to combine lens and mirror in one by using a glass of peculiar shape, in which rays from external objects are first refracted at a convex surface, then totally reflected at the back of

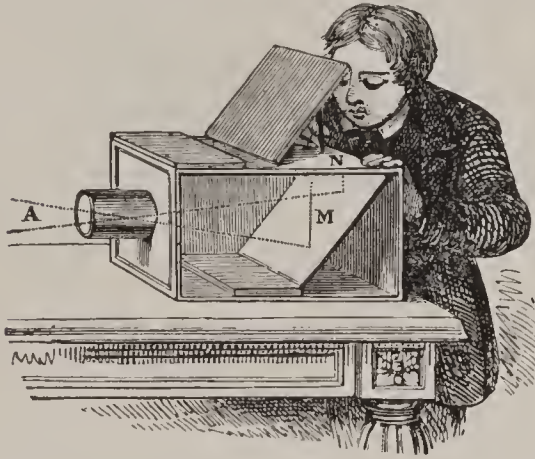

Camera Obscura.

the lens, which is plane, and finally emerge through the bottom of the lens, which is concave, but with a larger radius of curvature than the first surface. The camera obscura employed by photographers is commonly a box, one half of which slides into the other, with a tube in front containing an object-glass at its extremity. At the back of the box is a slide of ground glass, on which the image of the object or objects to be depicted is thrown, in setting the instrument. The focussing is performed in the first place by sliding the one half of the box into the other, and by means of a pinion attached to the tube in front which moves the lens. When the image has thus been rendered as sharp as possible, the ground-glass slide is removed, and a sensitized plate substituted, which not only receives, but retains the image.

**Cam'erino**, a town of Central Italy, province of Macerata, 41 miles s.w. of Ancona, seat of an archbishopric, with archiepiscopal palace and a spacious cathedral. Pop. 11,761.

**Cam'erlengo**, or **CARDINALE CAMERLENGO**, the chamberlain or highest officer in the papal household, and formerly also the head of the government.

**Cam'eron**, **RICHARD**, a Scottish Covenanter, born at Falkland in Fife. Becoming an enthusiastic votary of the pure Presbyterian system, on the 20th of June, 1680, at the head of a small band of followers, he entered Sanquhar, and formally renounced allegiance to the king (Charles II.) on account of his misgovernment. The little

band kept in arms for a month in the mountainous country between Nithsdale and Ayrshire, but were at length surprised by a much superior force at Aird's Moss, and after a stubborn fight overcome. Cameron was amongst the slain. See *Cameronians*.

**Cameron**, **VERNEY LOVETT**, African traveller, born near Weymouth in 1844. He entered the British navy in 1857, and in 1872 was chosen by the Royal Geographical Society of London to conduct an expedition for the relief of Dr. Livingstone. He was only in time to meet the remains of Livingstone at Unyanyembe, but continued his journey west to Benguela, and was thus the first to cross Central Africa. Returning to England in 1876, he was made Companion of the Bath, and raised to the rank of a commander. In 1878 he made a journey through Asia Minor and Persia. He has published accounts of both journeys in his *Across Africa and Our Future Highway to India*.

**Cameron Highlanders**, the 79th Regiment in the British army, raised in 1793 by Allan Cameron of Erroch. It wears the Highland dress.

**Cameronian Regiment**, a British regiment raised in 1689 amongst the Cameronians of the west of Scotland to support William III., and long famous as the 26th Regiment. It forms now the first battalion of the Cameronians (Scottish Rifles).

**Cameronians**, the name applied to the small but zealous sect of Presbyterians which Richard Cameron led.

**Cameron**, **SIMON**, born near Lancaster, Pa., 1799, died at Harrisburg, 1889; one of the most active politicians of his time; was U. S. Senator, Minister to Russia and Sec. of War in Mr. Lincoln's administration.

**Cameroons**, (1) a district on the West Coast of Africa, on the Bight of Biafra, now belonging to Germany, and one of the most suitable districts for colonization in this region. (2) A river in the Cameroons territory. It falls into a broad estuary, on approaching which it has a width of about 400 yards. There are several large and thriving towns (including King Bell's town) on the river, through which an extensive trade is carried on in ivory and palm-oil. (3) A mountain range in the territory, the highest peak of which has been estimated at over 13,000 feet. It is volcanic in character, and is clothed with a dense growth of forest to the height of 4000 or 5000 ft.



**Camillus**, MARCUS FURIUS, a Roman patrician, famous as the deliverer of the city of Rome from the Gauls. In B.C. 396 he was made dictator during the Veientine war, and captured the town of Veii by mining, after it had defied the Roman power for ten years. In B.C. 394 Camillus besieged the Falerii, and by an act of generosity induced them to surrender. Three years after, the envy and jealousy of enemies caused him to exile himself for a time, and he was living in retirement when the Gauls under Brennus invaded and captured Rome, with the exception of the Capitol. Camillus was now appointed dictator a second time, and was successful in repelling the invaders. After having been four times appointed dictator, a new invasion of the Gauls called Camillus, now eighty years old, again to the front, and for the fifth and last time, being appointed dictator, he defeated and dispersed the barbarians. He died in B.C. 365. Probably there is a certain amount of myth in the story of his life.

**Cam'isards**, Calvinists in France (in the Cevennes), who, in the beginning of the 18th century, in consequence of the persecution to which they were exposed after the revocation of the Edict of Nantes in 1685, rose against the royal deputies. A large army was required to put them down (1702-1705), and great numbers were massacred, the French government considering it a laudable work to suppress the Protestant heresy in this bloody manner. The name is from *camise*, a provincial form of French *chemise*, a shirt, because their ordinary outer garment was a kind of shirt or blouse.

**Camlet**, a fabric made of long wool, hand spun, sometimes mixed with cotton, silk, or linen: originally made of camel's hair or of the hair of the Angora goat.

**Cam'oens**, LUIS DE, the most celebrated poet of the Portuguese, born at Lisbon of a good family, probably in 1524 or 1525. Disappointed in love, he became a soldier, and served in the fleet which the Portuguese sent against Marocco, losing his right eye in a naval engagement before Ceuta. An affray into which he was drawn was the cause of his embarking in 1553 for India. He landed at Goa, but, being unfavourably impressed with the life led by the ruling Portuguese there, wrote a satire which caused his banishment to Macao (1556). Here, however, he was appointed to an honourable position as administrator of the

property of absentee and deceased Portuguese, and here, too, in what were the quietest and most prosperous years of his life, he wrote the earlier cantos of his great poem, the *Lusiads*. Returning to Goa in 1561, he was shipwrecked and lost all his property except his precious manuscript. After much misfortune Camoens in 1570 arrived once more in his native land, poor and without influence, as he had left it. The *Lusiads* was now printed at Lisbon (1572), and celebrating, as it did, the glories of the Portuguese conquests in India, acquired at once a wide popularity. The king himself accepted the dedication of the poem, but the only reward Camoens obtained was a pittance insufficient to save him from poverty; and it is said that his faithful Javanese servant had often to beg food for them both in the streets. He died on the 18th June, 1579. Fifteen years after his death a magnificent monument was erected to his memory, with an inscription on it which called him the prince of poets. The *Lusiads* is an epic poem in ten cantos. Its subject is the voyage of Vasco da Gama to the East Indies; but many other events in the history of Portugal are also introduced. The other works of Camoens consist of sonnets, songs, epigrams, dramas, &c. The *Lusiads* has been translated into English by William J. Mickle and Sir R. F. Burton as well as by others.

**Camomile**. See *Chamomile*.

**Camor'ra**, a well-organized secret society, once spread throughout all parts of the kingdom of Naples. At one time the *Camorristi* were all-powerful, levying a kind of blackmail at all markets, fairs, and public gatherings, claiming the right of deciding disputes, hiring themselves out for any criminal service from the passing of contraband goods to assassination. It had central stations in all the large provincial towns, and a regular staff of recruiting officers. Though properly a secret society, it did not find it necessary under the régime of the Bourbons to conceal its operations; but under the present government of united Italy, the society, if it has not quite ceased to exist, has lost almost all its power, except in the wilder parts of Southern Italy.

**Camp**, the place and aggregate body of tents or huts for soldiers in the field. Among the Greeks, the Lacedæmonians seem to have been the first who devoted attention to the art of forming military camps, adopting a circular form with the general's tent in the

centre; but the Romans, who had so often to carry on wars in distant and thinly-populated regions, were the first to carry the art of encampment to a high degree of perfection. Their camps as a rule were square, and were strongly intrenched so as to provide against the danger of surprise. Since the invention of gunpowder intrenched camps have become much more elaborate affairs and cover a much greater area. They may consist of intrenched areas permanently connected with and under the protection of fortified places; thus they are sometimes attached to certain large cities on the chief roads, partly in order to defend them against the first attack of the enemy, partly to give to retreating armies rallying-points able to furnish support to numerous soldiers. Camps which, though intrenched, are to be occupied merely for the period of a campaign, or which serve as a refuge for a few days only to a subordinate army, are termed 'lines' or 'temporary positions.' From the perfection of modern artillery strong detached forts form the chief defensive feature of intrenched camps of the present day.—*Camps of instruction* are formed in time of peace for training and disciplining soldiers in camp life.

**Campagna** (kām-pān'yā), a town of S. Italy, province of Salerno, surrounded by high mountains. It is the seat of a bishopric, and contains a superb cathedral. Pop. 9028.

**Campagna di Roma** (kām-pān'yā), the coast region of Middle Italy, in which Rome is situated, from 30 to 40 miles wide and 100 long, and forming the undulating mostly uncultivated plain which extends from near Civita Vecchia or Viterbo to Terracina, and includes the Pontine Marshes. The district is volcanic, and its lakes, Regillus, Albano, Nemi, &c., are evidently craters of extinct volcanoes. The soil is very fertile in the lower parts, though its cultivation is much neglected, owing to the malaria which makes residence there during midsummer very dangerous; and during the months of July, August, and September its inhabitants, chiefly herdsmen and peasants, seek refuge in Rome or the neighbouring towns. In ancient times the Campagna, though never a salubrious district, was well cultivated and populated, the villas of the Roman aristocracy being numerous here. But inundations from the Tiber, and the discouragement of agricultural industry in the midst of wars and devastations, left the stagnant

waters to become a source of pestilence, and the district became little better than a desert, nothing of its former prosperity being visible but the ruins of great temples, circuses, and monuments, and long rows of crumbling aqueducts overgrown with ivy and other creeping plants. Attempts to redeem part of the Campagna have often been made, but without much success. Recently the Italian government has taken up the problem, and with the large resources now at its command may be able to effect some good.

**Campaign** (kam-pān') generally denotes the series of operations of an army during the time it keeps the field in one season or accomplishes a determinate object. Formerly campaigns lasted only during the warmer months, and were terminated by the troops retiring into winter quarters.

**Campan**, JEANNE LOUISE HENRIETTE, born at Paris in 1752, became reader to the daughters of Louis XV.; afterwards gained the favour of Queen Marie Antoinette, and, as lady of the bed-chamber, served that ill-fated sovereign with much fidelity till the events of the Revolution separated them. After the fall of Robespierre Madame Campan established a boarding-school for young ladies at St. Germain, which soon acquired a wide reputation. She is chiefly remembered for her interesting memoirs respecting the private life of Marie Antoinette, her *Journal of Anecdotes*, and her correspondence with Queen Hortense.

**Campanella**, TOMMASO, a learned Italian monk, born 1568. He entered the order of the Dominicans and studied theology and other branches of knowledge with assiduity, but was principally attracted by philosophy. In 1591 he published at Naples a philosophical work intended to show the futility of the prevailing doctrines of the Aristotelian schools. This book procured him some admirers, and more enemies. In 1599 he was arrested on a charge of conspiracy against the Spanish government, to which Naples was then subject, was imprisoned, and, after being repeatedly tortured, condemned to perpetual confinement. In this situation he wrote many learned works, afterwards published. At length, in 1629, Pope Urban VIII. procured his liberty and bestowed a pension on him. Dreading further persecution, he withdrew in 1634 to France, where he was honourably received. He died in Paris in 1639. Among his numerous works are *Atheismus Triumphatus*; *Discorsi della*

*Libertà*; *Prodrōmus Philosophiæ Instaurandæ*; *De Sensu Rerum et Magia*.

**Campane'ro**, the bell-bird.

**Campan'nia**, the ancient name of a province of Italy, in the former kingdom of Naples, which, on account of its beauty and fertility, was a favourite resort of wealthy Romans, who built there magnificent country houses. It comprises the modern provinces of Caserta, Naples, and parts of Salerno and Avellino. Cumæ (the oldest Greek settlement in Italy), Puteoli, Naples, Herculaneum, Pompeii, Baiæ, Stabiæ, Salernum, and Capua (its ancient capital) were the principal cities of Campania. Even now Campania is the most beautiful and fruitful part of Italy.

**Campanile** (kam-pa-nē'lā), a bell-tower detached from the church to which it belongs, common in the church architecture of Italy. Amongst the most remarkable examples are the beautiful campanile of the cathedral at Florence, designed by Giotto, and the famous leaning tower of Pisa.

**Campan'ula**, the bell-flower genus, a large genus of plants which gives its name to the order Campanulaceæ. The species are herbaceous plants, with bell-shaped flowers usually of a blue or white colour. It includes several American species, which are known to all lovers of wild flowers. *C. rotundifolia*, the hare-bell or rock-bell flower, found in all the States on damp rocks and rocky streams, is an exceedingly delicate plant. *C. aparinoides* is the prickly bell-flower.

**Campanula'ceæ**, the bell-worts, an extensive nat. order of monopetalous dicotyledonous plants, usually herbaceous, with an inferior two or more celled fruit, many minute seeds, regular bell-shaped showy blue or white corolla, and milky acrid juice. They are natives chiefly of northern and temperate regions. See *Campanula*.

**Campbell of Argyle**. See *Argyle*.

**Campbell, SIR COLIN**. See *Lord Clyde*.

**Campbell** (kam'bel), GEORGE, a Scottish divine, born at Aberdeen in 1709, educated at Marischal College, and in 1759 appointed principal of this college. In 1763 he published a celebrated dissertation on miracles in answer to Hume, and in 1776 his *Philosophy of Rhetoric*, which established his reputation as a critic and thinker. He died in 1796.

**Campbell, JOHN, LORD CAMPBELL**, Lord-chancellor of England, was the son of Dr. George Campbell, minister of Cupar-Fife,

and was born there in 1779. He was educated at Cupar, and afterwards at the University of St. Andrews. In 1798 he went to London, and after acting some time as reporter and theatrical critic to the *Morning Chronicle*, entered himself a student of Lincoln's Inn, and in 1806 was called to the bar. He acquired a considerable practice, was elected member for Stafford in 1830, and two years after made solicitor-general. In 1841 he was created Lord-chancellor of Ireland and raised to the peerage as Baron Campbell of St. Andrews. Some years after he accepted a post in the ministry of Lord John Russell; in 1850 was made chief-justice of the Queen's Bench, and nine years after was raised to the woolsack as lord-chancellor. He died 23d June, 1861. He is known as the author of a considerable work, *Lives of the Chancellors*, which, with its supplementary vols., *Lives of the Chief-justices*, enjoyed great popularity.

**Campbell, THOMAS**, a distinguished modern poet, was born at Glasgow 27th July, 1777, and educated at its university. After leaving the university he resided for a short time in Edinburgh; and all at once attained the zenith of his fame by publishing, in 1799, his *Pleasures of Hope*. It produced an extraordinary sensation, and soon became a familiar book at almost every hearth throughout the kingdom. In 1803, after spending some time in Germany, Campbell published an edition of the *Pleasures of Hope* with the addition of some of the finest lyrics in the English language, including *Hohenlinden*, *Ye Mariners of England*, and *the Exile of Erin*. In 1803 he went to London, and in 1806 obtained a pension of £200 through the influence of Mr. Fox. After this he appears for a time to have given his attention less to poetry than prose, and wrote various compilations, articles for *Brewster's Edinburgh Encyclopædia*, &c. In 1809 he again made his appearance as a poet, and published *Gertrude of Wyoming*, *Lord Ullin's Daughter*, and *the Battle of the Baltic*. After publishing *Specimens of English Poets* accompanied by critical essays, he became editor in 1820 of the *New Monthly Magazine*. He took an active part in the foundation of London University, and in 1827 was elected rector of Glasgow University. After this, though he continued to occupy himself with literature, published his *Letters from the South*, a *Life of Mrs. Siddons*, and a *Life of Petrarch*, his productions were much inferior to his earlier efforts. He

## CAMPBELL ISLAND — CAMPHOR.

died at Boulogne, 15th June, 1844, and was interred at Poet's Corner in Westminster Abbey, close to the tomb of Addison.

**Campbell Island**, a small uninhabited island in the S. Pacific, south-east of New Zealand, to which it belongs. Mountainous and well wooded, and with fine harbours occasionally visited by whaling vessels.

**Campbeltown**, a royal and parliamentary burgh and seaport of Scotland in Argyleshire, near the south end of Cantyre, at the head of a bay or loch. Anciently the town was called Dalruadhain, and it was the earliest seat of the Dalriadan monarchy in Scotland. There are many whisky distilleries, and the trade consists chiefly in the export of whisky, farm produce, and herrings. Along with Ayr and other places it sends a member to parliament. Pop. 7603.

**Cam'pe**, JOACHIM HEINRICH, a German author and publisher, born in 1746. In 1777 he became director of the Educational Institute of Dessau, and afterwards superintendent of the schools in the duchy of Brunswick. At Brunswick he became the head of a publishing house which soon became famous over all Germany, his own works, consisting mostly of books for youth, such as *Robinson the Younger*, adapted from Defoe, *Discovery of America*, &c., contributing greatly to extend its reputation. Campe died in 1818.

**Campeachy**, or CAMPECHE (kan'pē-chi, kan'pech-e), a seaport of Mexico, in the state and on the bay of the same name, on the w. coast of the peninsula of Yucatan, a mart for logwood and wax. Cigars are manufactured, and ships are built, though the harbour can only admit small vessels. Pop. 15,196.—The state Campeachy has an area of 18,087 sq. m.; pop. 1890, 93,976.

**Campen.** See *Kampen*.

**Camper**, PETER, Dutch physician and anatomist, professor of medicine, &c., successively at Franeker, Amsterdam, and Groningen, born at Leyden 1722, and died at the Hague 1789. His contributions to anatomy and physiology were valuable. He was also skilful in drawing and painting, and rendered important services to art in his work on the relations of anatomy and art. One of his doctrines is that of the facial angle. See *Facial Angle*.

**Camperdown**, or CAMPERDUIN, sandy hills or downs on the coast of Holland, south of the Helder, off which the British, under Admiral Duncan, gained a hard-won

naval victory over the Dutch, under De Winter, October 11, 1797.

**Camphene** (kam'fēn), the generic name for the volatile oils or hydrocarbons, isomeric or polymeric with oil of turpentine, as oil of bergamot, cloves, copaiba, hops, juniper, orange, pepper, &c. They are liquid at ordinary temperatures, and are distinguished from each other by their odours.

**Camphine** (kam'fēn), the commercial term for purified oil of turpentine, obtained by distilling the oil over quicklime to free it from resin. It is used in lamps, and gives a very brilliant light; but, to prevent smoking, the lamp must have a very strong draught. With oxygen it forms camphor.

**Cam'phor**, a whitish translucent substance, of a granular or foliated fracture, and somewhat unctuous to the touch, which is mostly extracted from two or three kinds of trees of the laurel tribe. It has a bitterish aromatic taste and a strong characteristic smell. In chemical character it belongs to the vegetable oils. The common camphor of the shops is obtained from *Camphōra officinārum* (*Cinnamōmum* or *Laurus Camphōra*), the camphor laurel, a native of



Camphor-tree (*Camphora officinarum*).

China and Japan, now naturalized in many other countries. The camphor is chiefly prepared in the island of Formosa, though also exported from Japan, and to a small extent from China. *Borneo camphor* is the product of *Dryobalanops Camphōra*, nat. order Dipteraceæ, a tree 100 to 130 feet high, found in Borneo and Sumatra. The common camphor is obtained from the wood by distillation and sublimation. Borneo camphor, on the other hand, is not procured by distillation, but is found in masses, secreted naturally in cavities in the trunk and greater branches. Numerous other vegetables, such as thyme, rosemary, sage, &c., are found to yield camphor by distillation. In medicine camphor is used both as an external and internal stimulant. In small doses it acts as an anodyne and antispasmodic; in large doses it acts as a poison. Its effluvia being very noxious to insects, it is much used to

protect specimens in natural history. It readily dissolves in alcohol, oils, &c., and in this way is much used as a liniment. It evaporates or volatilizes at ordinary temperatures. A third kind of camphor, *blumea camphor*, is prepared in China from *Bluměa balsamifěra*, a tall composite plant.

**Campi**, a family of Italian artists who founded what is known in painting as the school of Cremona. Of the four of this name, Giulio, Antonio, Vincenzo, and Bernardino, the first and the last are the best known. Giulio (1502–72), the eldest and the teacher of the others, was a pupil of Giulio Romano, and acquired from the study of Titian and Pordenone a skill in colouring which gave the school its high place. Bernardino (1525–90) was the greatest of the school. He took Romano, Titian, Correggio in succession as his models, but without losing his own individuality as an artist.

**Cam'pion**, the popular name of certain plants. See *Lychnis* and *Silene*.

**Cam'pion**, EDMUND, an English Jesuit, born 1540. He was educated at Oxford, and distinguished himself greatly. Though at first a Roman Catholic, he adopted nominally the Reformed faith, and took deacon's orders in the Church of England; but he afterwards recanted, became a Jesuit, and attacked Protestantism, especially in his work *Decem Rationes* (Ten Reasons). In 1581 he was found guilty on a trumped-up charge of conspiring to raise sedition, and was accordingly executed.

**Campobas'so**, a town of Italy, province of Campobasso, on a hill-slope, 52 miles N.E. Naples; has manufactures of cutlery, and a good trade. Pop. 14,818.—The prov. (formerly Molise) has an area of 1771 sq. miles; pop. 385,140.

**Campobel'lo**, an island 8 miles long, belonging to New Brunswick, Canada, in the Bay of Fundy, with a lighthouse on its northern extremity.

**Campo-Formio**, a town in Italy, 66 miles N.E. of Venice, famous for the treaty of peace between Austria and France which was signed in its neighbourhood on the 17th of October, 1797. Its chief provisions were that Austria should cede the Belgian provinces and Lombardy to France, receiving in compensation the Venetian states.

**Campo-Santo** ('lit. Holy Field'), the name given to a burying-ground in Italy, best known as the appellation of the more remarkable, such as are surrounded with arcades and richly adorned. The most famous

Campo-Santo is that of Pisa, which dates from the 12th century, and has on its walls frescoes of the 14th century of great interest in the history of art. Amongst more modern Italian cemeteries, that of Genoa is distinguished for its magnificence.

**Campus Martius** (called also *Campus*, merely) was a large place in the suburbs of ancient Rome, consisting of the level ground between the Quirinal, Capitoline, and Pincian hills, and the river Tiber, set apart for military exercises and sacred to the god Mars. In the later period of the republic it was a suburban pleasure-ground for the Romans, and was laid out with gardens, shady walks, baths, &c. Large part of the modern city stands on it.

**Camp'vere**, now *Veere*, *Vere*, or *Ter-Vere*, a fortified maritime town in Holland, in the province of Zeeland, on the island of Walcheren, 4 miles N.N.E. of Middelburg. It once had some shipping trade, building-yards, &c., but has greatly fallen off. Historically Campvere is remarkable from having been for a long period the town in which the Scotch merchants had their staple in Holland, that is, the town in which all goods sent from Scotland to the Netherlands were deposited until they were sold. The Scotch living at Campvere formed in some respects a separate community, and enjoyed various privileges. They had their own church, and were governed by the law of Scotland. Pop. 923.

**Cam'toos**, a river of Southern Africa, in Cape Colony, which falls into the sea west of Algoa Bay; length, 200 miles.

**Camuccini** (kă-muĭt-chě'nē), VINCENZO, a distinguished Italian historical painter, born at Rome about 1775. He followed the pseudo-classical style, and his pictures are of large size. Among his best-known works are *Death of Cæsar*, *Death of Virginia*, *The Incredulity of Thomas*, *Horatius Cocles*, *Death of Mary Magdalene*. He was also excellent in portraits. He died in 1844.

**Camwood**, a red dye-wood imported from tropical West Africa, and obtained from the *Baphia nitida*, a leguminous tree, sub-order Cæsalpinieæ. This wood is of a very fine colour, and is used in turnery for making knife handles and other similar articles. The dye obtained from it is brilliant, but not permanent. It is called sometimes *Barwood*, though this name belongs also to another tree.

**Cana**, a village of Palestine, in Galilee, the scene of Christ's first miracle; probably

represented by Kana el Jelil, a modern village 9 miles N. of Nazareth.

**Canaan** (kā'nān). See *Palestine*.

**Canaanites**, the general name for the heathen peoples (Jebusites, Hittites, Amorites, &c.) whom the Israelites found dwelling in Canaan (Palestine) west of the Jordan, and whom latterly they utterly subdued, though the subjugation was not quite complete till Solomon's time. They are believed to have been, in part at least, of kindred race with the Israelites; and some authorities find traces of their descendants among the present inhabitants of Palestine.

**Canada**, DOMINION OF, an extensive series of British territories in North America, the greatest of Britain's colonial possessions, comprising the provinces of Ontario (formerly Upper Canada), Quebec (formerly Lower Canada), Nova Scotia, New Brunswick, British Columbia, Prince Edward Island, and Manitoba, along with the vast regions in the north and north-west known as the North-west Territories, and another vast region north of Quebec known as the North-east Territory. The Dominion thus embraces the whole of British North America, with the exception of Newfoundland and part of Labrador (which belongs to Newfoundland), and its area is not much less than that of Europe. The following table shows the present areas of the provinces of the Dominion (some of which have recently had their boundaries altered), with their populations on the 3d of April, 1891.

Provinces.	Area . sq. m.	Pop. in 1891.
Alberta.....	106,100	25,278
Assiniboia.....	89,535	30,374
Athabaska.....	104,500	.....
British Columbia.....	3-3,300	92,767
Manitoba .....	73,956	154,442
New Brunswick.....	28,200	321,270
Nova Scotia.....	20,907	450,523
Ontario.....	222,000	2,114,475
Prince Edward Island...	2,300	109,088
Quebec.....	228,900	1,488,586
Saskatchewan.....	107,092	11,146
Unorganized Territory..	2,090,200	31,462
<b>Total.....</b>	<b>3,466,690</b>	<b>4,820,411</b>

Nova Scotia, New Brunswick, and Prince Edward Island are called the 'Maritime Provinces,' though British Columbia, being on the Pacific, is also a maritime province. In the North-west Territories four districts have recently been marked out: Assiniboia, area, 89,535 sq. m.; Saskatchewan, 107,092 sq. miles; Alberta, 106,100 sq. miles; Athabasca, 104,500 sq. miles. There is also the

district of Kewatin, subordinate to Manitoba. The boundaries of the Dominion are: the Atlantic on the east, the United States on the south, the Pacific and Alaska on the west, and the Arctic Ocean on the north.

*Coasts.*—On the east the coast-line is very irregular, being marked by deep indentations and fringed by islands. The province of Nova Scotia forms an odd peninsular projection with the Bay of Fundy between it and the mainland, while north of it is the Gulf of St. Lawrence, shut in from the Atlantic by Cape Breton Island and Newfoundland. In the gulf are the island of Anticosti and Prince Edward Island. The chief features of the north coast are the archipelago of the Arctic islands and the great opening of Hudson Bay, connected with the Atlantic by Hudson Strait, and having as its southern continuation James Bay. On the west coast are Vancouver Island, the Queen Charlotte Islands, and many others. The southern boundary is most remarkable for passing through the system of great lakes—Superior, Huron, Erie, and Ontario, between the last two of which are the Falls of Niagara, partly belonging to Canada, partly to the United States. To the Atlantic the drainage of these lakes is carried by the St. Lawrence, with which river, and the great gulf into which it expands, are connected the provinces of Ontario, Quebec, New Brunswick, Nova Scotia, and Prince Edward Island, together containing by far the greater portion of the population of the Dominion.

*Surface.*—With regard to the character of the surface, Canada may be divided roughly into three great regions: a region of woodlands and hills or undulating ground in the east, an immense region of prairies in the middle, and a mountainous forest region in the west. The chief mountain ranges of the east are north and south of the St. Lawrence, and run nearly parallel to that river. On the south are the Shickshock Mountains and the Notre Dame range, the former rising to the height of 4000 ft. On the north is the Laurentian range (perhaps attaining 4000 ft.), running in a westerly direction from the Labrador coast to the Ottawa river, and forming the watershed between the rivers which flow into the St. Lawrence and those which flow into Hudson Bay. The prairie region and great wheat-producing tract extends north-west of Lake Superior to the Rocky Mountains. This is a great region of plains, with low hills in some places; it is well wooded in many parts, elsewhere

## CANADA.

bare or with an agreeable mixture of woodland and prairie. Some portions are decidedly infertile, but their area is small compared with the whole. On the Pacific slope we have a distinctly mountainous region, including the Rockies, some peaks of which (Mt. Hooker, Mt. Brown) attain a height of about 16,000 ft., as also the Gold and the Cascade Ranges. This region, with its high mountains, deep gorges or canyons, large and rapid rivers, long and narrow lakes, great forests of gigantic trees, and its narrow fiords or inlets, presents an aspect peculiar to itself.

*Lakes and Rivers.*—The vast lake and river systems which Canada possesses of its own, or shares with the United States, give it a unique character. Everywhere in the interior are rivers and lakes. To Hudson Bay flow the Albany, Nelson, Churchill, and many other streams; to the Arctic Ocean, the Mackenzie, Coppermine, and Back or Great Fish River; to the Pacific, the Fraser, Skeena, Stickeen, &c. The basin of the St. Lawrence, with the connected lakes Superior, Huron, Michigan, Erie, and Ontario, affords a continuous waterway from the Atlantic to the interior of the continent. To this system belong the Ottawa, Gatineau, Richelieu, St. Maurice, Saguenay, and other rivers. In the prairie region and the north-west are similar great lake and river systems, formed by the Saskatchewan, Nelson, Churchill, Athabasca, and Mackenzie rivers, and the great lakes Winnipeg, Athabasca, Great Slave and Great Bear. The Saskatchewan, lying in the heart of the rich wheat-growing district, must in time prove a far more important waterway than at present. The Mackenzie and its connected lakes and rivers form the most remarkable feature of the far north-west. This river, including its tributary the Peace, has a length of perhaps 2500 miles, and drains an area of 550,000 sq. miles, or almost double that of the St. Lawrence basin. Between the Mackenzie system and Hudson Bay is a great region called from its desolate character the Barren Grounds.

*Geology and Minerals.*—As regards the geological features of Canada, great part of the Dominion north of the St. Lawrence and west of Hudson Bay is covered with archæan rocks belonging to the Laurentian system, and consisting largely of granite and gneiss, with quartz-rock, schist, limestone, &c. South of the St. Lawrence, in New Brunswick and Nova Scotia, is a considerable development

of Carboniferous strata. Between the archæan rocks and the Rocky Mountains is a great area of secondary (Mesozoic) strata. In the Rocky Mountain region the archæan, palæozoic, mesozoic, and tertiary systems are represented. Canada has great mineral wealth. Iron of the best quality has been found in great abundance in Quebec, Ontario, and British Columbia. The district round Lake Superior and the upper part of Lake Huron abounds in copper and has much silver as well; and Nova Scotia, Assiniboia, Alberta, and British Columbia are rich in coal. In Nova Scotia there are a number of coal-mines worked; gold is also obtained in some quantity, as well as iron. Coal is worked in the north-west, and more extensively in British Columbia; but the most valuable mineral of the latter is gold, of which more than \$50,000,000 has been obtained since 1858. British Columbia is also rich in iron. Large quantities of petroleum are obtained. The chief oil district is the peninsula in the province of Ontario formed by Lakes Erie and Huron and the river St. Clair. Other useful mineral products are salt, gypsum, phosphate of lime, slate, asbestos, plumbago, antimony, and building-stone.

*Animals.*—The chief wild animals (some of them represented by several species) are the deer, buffalo, musk-ox, bear, wolf, fox, otter, beaver, squirrel, raccoon, musk-rat, marten, &c. The buffalo is now scarce, and will probably soon be exterminated. The largest of the deer kind is the moose, or elk, which is found in New Brunswick, Nova Scotia, and the northern parts of Quebec, as well as in the far west and north-west. The reindeer occurs in the north. The grizzly bear is met with in the Rocky Mountains, and the polar bear in the extreme north and north-east. Fur-bearing animals are so numerous as to have been a source of revenue to a large trading company like the Hudson Bay Co. for over two centuries. There are birds in great variety, Canada having more than 700 of these altogether. They include the wild swan, wild turkey, geese and ducks of various kinds, partridges, quail, prairie-fowl, pigeon, woodcock, snipe, plover, &c.; besides eagles, hawks, owls, and many smaller birds, among which are two species of humming-bird. Except at certain seasons game of all kinds may be shot at will. The rattlesnake and other snakes occur, but are less common than in the States. The seas,

## CANADA.

lakes, and rivers, especially the Gulf of St. Lawrence and the neighbouring waters, abound in almost all kinds of fish, and the fisheries are extremely valuable, employing over 250,000 people. The chief sea fish caught are cod, herring, mackerel, halibut, haddock, hake, shad, salmon, &c. The rivers and lakes abound with salmon, white-fish, bass, trout, sturgeon, maskinonge (or maskelonge), pike, pickerel, &c. The seal and whale fisheries are also valuable. Lobsters and oysters are abundant and excellent.

*Vegetation.*—The forests are of great extent, and the timber trade is a great source of wealth, the value of the timber and forest products shipped in 1891 was \$24,282,015. In the forests grow more than sixty kinds of trees. Amongst the most valuable are the white and red pine, white and black spruce, maple, ash, beech, oak, walnut, butternut, chestnut, basswood, birch, cedar, &c. Over most parts of the Dominion (except in the prairie regions of the interior) good timber is found, though in the older and more closely-settled parts the forests have been largely cleared off. The forests of British Columbia produce the largest timber, the Douglas pine being the chief tree. The balsam poplar grows to an immense size on the Athabasca, Peace, and Mackenzie rivers, and even at the mouth of the last, within the Arctic Circle, trees of some size are found. The Banksian pine grows to the height of 100 feet on the southern shores of Hudson Bay; and spruce suitable for building purposes, and the tamarac or larch, extend as far north as Fort George on its east and Fort Churchill on its west shore. The sugar-maple, a forest tree attaining the height of 120 feet, flourishes in the greater part of the St. Lawrence valley up to lat. 49°, and is much valued for the sugar that is obtained from it. There are a great many varieties of wild fruits, as the wild plum, wild cherry, raspberry, service-berry, cranberry, gooseberry, strawberry, black and red currant, wild vine, blueberry, buffalo berry, &c., and numerous wild flowers and flowering shrubs. Of the wild fruits, the raspberry, the cranberry, and the blueberry are alone important economically. There are rich pasture grasses, but they cannot be utilized in cultivation.

*Climate.*—The climate of a country of such vast extent and varied features as Canada naturally differs very much in different places, and in this respect British Columbia on the Pacific coast, and Nova Scotia and the other

Atlantic regions are very dissimilar to the prairie region of the centre. So different, indeed, is the climate of one portion of the Dominion from that of other portions that Canada has been said to present 'climates and productions similar to those of north-west and central Europe—that is, of Russia, Norway, the British Islands, Denmark, Germany, France, Holland, Belgium, Switzerland, and Northern Italy.' In Ontario and the region of the Upper St. Lawrence it may be described as temperate, although the heat in summer and the cold in winter are on the average twenty degrees greater than the corresponding seasons in Great Britain. Generally the climate of the Dominion shows considerable extremes of heat and cold, but, except in some of the coast regions, the exceeding dryness of the Canadian atmosphere makes both extremes of temperature more pleasant and healthy than similar temperatures in Britain. Apart from the portions of the Dominion that fall within the Arctic Circle, Labrador and all the country east of Hudson Bay have the most severe climate. The Pacific coast region has a decidedly moist climate. The peninsula lying between Lakes Ontario, Erie, and Huron has the finest climate, allowing of fruits, shrubs, and flowers to be grown that cannot stand the winter elsewhere. The Mackenzie River district—especially in the region of the Peace River, where the temperature throughout the year is remarkably genial—possesses a climate much less severe than one might expect, and would allow of agriculture almost to the Arctic Ocean.

*Agriculture.*—Both by soil and climate Canada is specially adapted for agriculture. Within the last few years its agricultural importance has greatly increased, and when the great prairies are brought under cultivation Canada will be one of the chief agricultural countries in the world. In general, sowing is later than in the northern parts of Britain, but the harvest is gathered earlier, a large part of it usually before the end of July, so rapid is the growth during the hot Canadian summer. The chief crops are wheat, barley, oats, rye, pease, maize, buckwheat, potatoes, turnips, mangel-wurzel, &c. The breeds of cattle are now being much improved, partly by the introduction of high-class cattle from Britain; and cattle, horses, and sheep are exported. The total value of all exports connected with agriculture, including grain, flour, animals and animal products (as cheese, eggs, &c.), was



## CANADA.

\$47,000,000 in 1891. The province of Ontario has an agricultural college and model farm at Guelph, and there are also model farms in Quebec. Fruit-growing is now an important industry in certain localities, and large quantities of apples are exported, as well as canned and dried fruits. Peaches are grown to most advantage in the Niagara district of Ontario, where peach orchards many acres in extent are to be seen. The vine is cultivated too, and good wine is made. Pears, plums, and many kinds of berry fruits, &c., are produced in great perfection.

*Commerce.*—The trade of the Dominion is chiefly with Great Britain and the United States. About four-fifths of the whole exports are sent to these two countries, while nearly nine-tenths of the imports come from them, sometimes more than one-half being from Great Britain alone. Besides timber, animals and their produce, and agricultural products, the chief articles of export are fish, coal and other minerals, leather, and wooden goods. The total exports in 1892 were valued at \$113,963,375, the total value of imports at \$116,978,943. The fiscal year ending June 30, 1898, was the largest on record. The aggregate trade was \$289,536,996 as against \$245,297,144 for 1897, an increase of \$44,059,000. Imports, \$130,630,195. Exports, \$158,726,801. The imports (1892) from Great Britain, \$41,348,435; United States, \$53,137,572; Germany, \$3,583,530; France, \$2,402,634; West Indies, \$4,092,287; China and Japan, \$3,016,857; South America, \$910,491. Among ship-owning countries Canada follows Britain, the U. States, and Norway. A uniform decimal system of coinage was established throughout the Dominion in 1871. The unit of account is the dollar of 100 cents, the value of which is declared to be on the basis of 486 cents and two-thirds of a cent to the pound of British sterling money. The average rate of exchange makes the dollar equal to about 4s. The money used consists of bank bills, and gold, silver, and bronze coins, besides government notes of small denominations up to 4 dollars, the bank bills being not of lower denominations than 5-dollars. There is a uniform system of weights and measures, the Canadian standards being the same as the British imperial standards. The British hundredweight of 112 lbs. and ton of 2240 lbs. are, however, superseded by the United States weights of 100 lbs. and 2000 lbs. respectively.

*Railways.*—The inland trade of Canada has been much improved by the completion of the various lines of railway, and is also greatly furthered by the extensive system of canals. Of the railways the greatest is the Canadian Pacific Railway, running from Montreal across the whole continent to Vancouver on the Pacific coast in British Columbia; length, about 2900 miles, exclusive of branches. (See *Canadian Pacific Railway*.) The Grand Trunk Railway, which crosses the St. Lawrence at Montreal by the stupendous Victoria Tubular Bridge (with its abutments nearly 2 miles long), connects the maritime provinces and the North-eastern U. States, with the western railways. Another important railway is the Intercolonial Railway from Halifax in Nova Scotia to Quebec. Altogether the Dominion has now (1893) 14,633 miles of railway. A railway has been begun to connect Winnipeg and Regina with Port Nelson on Hudson Bay, and thus to open up a shorter route from Britain to the centre of the continent than any yet existing. This route will only be available for perhaps half the year on account of the ice in Hudson Strait and Bay. From Winnipeg there is direct railway communication with the Western U. States, and this town is now an important centre of river navigation, steamers running up the Red River into the States, up the Assiniboine, and through Lake Winnipeg and up the Saskatchewan for 1500 miles.

*Canals.*—Some of the canals are stupendous achievements. The most important, from a commercial point of view, are the St. Lawrence Canals and the Welland Canal. The former series of canals, with an aggregate length of about 70 miles, avoids the rapids on the St. Lawrence between Montreal and Kingston on Lake Ontario, and thus affords to vessels the means of ascending to that lake (in descending vessels of 700 tons can shoot the rapids with safety); and the latter, which has a length of 27 miles, avoids the Niagara Falls and rapids, and enables vessels to ascend from Lake Ontario to Lake Erie. Both the Welland Canal and the St. Lawrence series have been enlarged and deepened so as to accommodate the increased traffic expected as a result of the settlement of the north-western provinces, and the construction of the Canadian Pacific Railway. The last canal necessary to complete the navigation of the St. Lawrence to Lake Superior is the small one on the United States side (in

## CANADA.

Michigan), avoiding the St. Mary rapids (Sault Ste. Marie), a tumultuous descent by which Lake Superior pours its waters into Lake Huron. Next after those mentioned, the most important of the Canadian canals is the series of locks and short artificial connections known as the Rideau Canal. It connects Lake Ontario at Kingston with the Ottawa near the city of that name. By means of these works large vessels can now sail by the St. Lawrence route from the Atlantic to the head of Lake Superior.

*Constitution, &c.*—By the Act of Confederation of 1867 the constitution of the Dominion was required to be similar in principle to that of the United Kingdom. There is a central federal government and separate provincial governments and legislatures. The central executive government is vested in the sovereign of Great Britain and Ireland, and is carried on in her name by a governor-general appointed by the crown, and a privy-council. The governor-general has a salary of £10,000 per annum. He is assisted by a privy-council consisting of the prime-minister and twelve other ministers or heads of departments. The legislative authority rests with a Parliament consisting of two houses, the Senate and the House of Commons. The Senate is now composed of eighty members, who are nominated by the governor-general. Each senator must be a born or naturalized subject, thirty years of age, and possessed of real or personal property to the value of at least 4000 dollars in the province for which he is appointed. There are twenty-four senators from the province of Ontario, twenty-four from Quebec, ten from Nova Scotia, ten from New Brunswick, three from Manitoba, three from British Columbia, and four from Prince Edward Island. The House of Commons is elected by the people for five years, there being one member for about every 20,000 of the population. There is a uniform franchise, a vote being given to every male of twenty-one years of age, possessed of a small property qualification. Each of the provinces has a separate parliament and administration, independent in its own sphere, at the head being a lieutenant-governor appointed by the central government. Ontario, Manitoba, and British Columbia have only one chamber; the other provinces have two. There is a very perfect system of municipal government throughout the Dominion, the counties

and townships having local governments or councils which regulate their local taxation. The administration of justice is based on the English model, except in Quebec province, where the old French law prevails. The only court that has jurisdiction throughout the Dominion (except the Exchequer and the Maritime Court) is the Supreme Court, the ultimate court of appeal in civil and criminal cases. In certain cases an appeal may be had to Her Majesty's Privy Council. The capital of the Dominion is Ottawa, but the largest cities are Montreal, Toronto, and Quebec. The Dominion revenue in 1892 was \$36,921,872; the expenditure was \$36,705,894; the debt stated \$295,333,274. Canada has both a large volunteer force and a militia. The former comprises many well-equipped organizations in infantry, cavalry, and artillery. A military college for the training of officers is maintained by the Dominion government at Kingston.

*Religion and Education.*—There is no state church in the Dominion. The prevailing religion in Quebec is that of the Roman Catholic Church. In Ontario Methodists predominate, then Presbyterians, the English Church, and the Roman Catholics. Of the total population in 1881, 1,791,892 were Roman Catholics, 742,981 Methodists, 676,165 Presbyterians, 574,818 Anglicans. Education is well attended to, being everywhere more or less under the supervision of government, and excellent free schools being provided. In Ontario, Quebec, and Manitoba separate public schools are provided for Roman Catholics; in the other provinces the schools are unsectarian. All the provinces except British Columbia have universities or colleges, and the provision made for higher education in general is exceptionally good, a fact which is said to have an observable influence on the tone of the periodical press.

*Literature.*—In literature proper Canada, as yet mainly occupied with its material development, has scarcely had time to produce writers of a distinctively national type of style and thought. But in poetry, fiction, philosophy, Canadian history, and descriptive narrative, there is no lack of writers who reflect the highest thought and culture of Europe. The French-Canadian literature of Lower Canada, though entirely dependent for its inspiration and models on the literature of France, deserves notice as containing some valuable works on Canadian

history and an interesting collection of essays, novels, and lyrics. Amongst the works which will give the reader some general idea of Canadian authors and their work, we may mention Lareau's *Histoire de la Littérature Canadienne*, Grant's *Picturesque Canada*, Morgan's *Bibliotheca Canadensis*, and *Canadian History and Literature* by Withrow and Adam.

*People.*—The population is increasing rapidly both naturally and by means of immigration. In the years 1882–86 the increase in the latter way was 498,227. The total population, 1891, was 4,820,411. Ontario is settled principally by emigrants from Great Britain and their descendants, with considerable numbers of Germans and Americans. In the province of Quebec the people are mostly French in origin, speech, and customs, being mainly descendants of the French colonists who inhabited the region before it became British. There are, besides, the Indian tribes and the Esquimaux, the latter in the extreme north. The Indians are estimated to number about 130,000. They are divided into various tribes as well as larger stocks or races, such as the Tinneh or Athabaskan Indians, the Thlinkets and Hydahs of British Columbia and the west coast, the Algonquins, Hurons, Iroquois, &c., of the St. Lawrence region. In the old provinces separate land allotments have been granted to the Indian population, and there the Indians have adopted a settled mode of life, and have made considerable advances in civilization. A separate department of the Canadian government exercises a general supervision over their affairs. Schools have been established among them, and they are said to learn to read and write quickly and to show some talent for music and drawing. The majority of the Indians, however, live beyond the influences of this kind of civilization, and wander over the plains of the north-west supporting themselves by fishing and hunting, carrying their furs to the various forts or trading stations of the Hudson Bay Company. They also make a number of articles out of wood, such as dishes, shovels, &c. Their canoes are ingeniously constructed of birch bark, and are made light enough to be carried for miles by a man or woman over the roughest *portages*, or places intervening between one navigable point and another. Frequently, however, the canoe is in a single piece, made by hollowing out the stem of a tree. Their dwellings or *wigwams* are of the simplest construction, con-

sisting merely of a frame of poles covered with birch bark, with a hole in the roof to serve for a chimney, and an opening covered with a blanket to serve for a door. There are also many half-breeds of mingled white (especially French) and Indian blood. These are intelligent and industrious, and engage in agriculture and other occupations, and usually speak a sort of corrupt French patois.

*History.*—English ships were the first to reach the shores of what is now Canada. In 1497 John Cabot, sailing from Bristol, landed on the coast of Labrador, and planted the English flag there. But it was the French navigator Jacques Cartier who first really opened up Canada for European settlers. In 1534 Cartier in a single ship sailed up the Gulf of St. Lawrence till he could see land on each side. Having returned the year following, he reached the Indian town of Hochelaga, to the height above which he gave the name of Mont Royal, now Montreal, and passed the winter at the mouth of the St. Charles, where the city of Quebec now stands. Some years later vigorous attempts at colonization were made. The Sieur de Roberval was appointed Viceroy of New France, as the newly-discovered territory had been called, and under his leadership and that of Cartier two hundred colonists were landed, who, after struggling for two winters with the hardships of their situation, had eventually to return. For the next fifty years no further attempts were made in these regions, except that on the part of the English, Martin Frobisher in 1576, and Sir Humphrey Gilbert in 1583, explored and took formal possession of Newfoundland and the adjacent coasts. In 1603 Samuel Champlain, a French naval officer, sailed up the St. Lawrence to where the city of Montreal now stands, and two years afterwards a settlement was made at Port Royal in Acadia (New Brunswick and Nova Scotia) in connection with a French fur trading company, but it was abandoned three years afterwards. At length, in 1608, a French colony under the leadership of Champlain and Des Monts settled at Quebec. Two years later another English navigator, Henry Hudson, explored the river and the bay which bear his name. In 1627, the fur trade having made considerable development under the guidance of Champlain, Cardinal Richelieu organized the company of the Hundred Associates for the further colonization of New France; but

## CANADA.

two years after the colony received a check in the capture of Quebec and other settlements by an English expedition under Sir David Kirk. The conquests, however, were soon restored to the French by the treaty of St. Germain-en-Laye. The growth of the colony, however, was slow. At Champlain's death in 1635 it numbered but 250 Europeans, and in 1663 was still under 2000. The most formidable foes of the colonists were the Iroquois Indians, who swarmed round the settlements, rooting up the mission stations of the French Jesuits, and pursuing the fugitives to the very walls of Quebec fort. In 1663, Colbert being at the head of affairs in France, fresh supplies of emigrants and a strong body of troops were sent out to Canada. The Iroquois found it advisable to make peace, and the soldiers, turning colonists, received grants of land under a kind of feudal tenure, their seigniors being often their former officers. Under the governorship of Count de Frontenac the explorations of Jesuit missionaries, and of the adventurers Joliet and La Salle, opened up the regions of the Mississippi and the 'Great West;' but the French generally preferred an adventurous life as *coureurs de bois* and trappers to the solid pursuits of agriculture. In 1682 a new war with the Iroquois broke out, in which the colonists, at first successful, latterly suffered severely, receiving a crushing blow in the massacre of Lachine, when 1200 Iroquois descended on the island of Montreal, fired the village of Lachine, and massacred its inhabitants.

The French colonists had scarcely recovered from this blow, which practically reduced their dominion to the military posts along the St. Lawrence, when war broke out between France and England, involving them in a strife with the British settlers in New England. The French struck the first blow by the burning of the British settlement at Corlaer (now Schenectady) and the massacre of its inhabitants. The British colonists retaliated; but the Peace of Ryswick put an end to the war without altering the position of the parties. In 1702 a new conflict arose, terminating in 1713 with the Peace of Utrecht, by which the British obtained Acadia, Newfoundland, and the regions around Hudson Bay, France retaining Canada, Cape Breton, &c. The thirty years of peace which followed was virtually a testing period for the colonizing capacities of the two nations. The

French did not altogether neglect industrial development; they laid the foundation of ship-building at Quebec, encouraged the fur trade and other industries; but in general their colonists lacked the qualifications for agricultural and other settled pursuits. The British colonists, on the other hand, stuck to agriculture, and reclaimed every year great tracts of forest land. As a natural consequence their population rapidly increased, and when the final struggle began, the British colonies in America numbered three millions of prosperous inhabitants against some sixty thousand French colonists hampered by feudal tenures, commercial monopolies, and a corrupt set of officials. In 1754 the French governor Du Quesne, an energetic and aggressive man, established new military posts in the Ohio Valley, and seized a newly-built British stockade on the spot where Pittsburg now stands. The French were already in occupation and had named the post Fort Du Quesne, when a force, despatched by the governor of Virginia and under the command of Colonel George Washington, arrived to take possession. They were met by a small party of French sent apparently to warn them off the ground. Washington, mistaking their intention, gave the word to fire, with the result that the French leader, Jumonville, was shot. Both sides at once prepared for war. The English government sent out two regiments under General Braddock, a brave but incapable leader, who allowed himself to be surprised and routed near the Monongahela, while marching on Fort Du Quesne at the head of over two thousand men. But an expedition against Crown Point under the leadership of General William Johnson drove the French within their intrenched camp at Ticonderoga. Now happened the incident of the expulsion of the Acadian peasants (immortalized in Longfellow's *Evangeline*), of whom about seven thousand still remained in Nova Scotia, mostly on the shores of the Bay of Fundy. Although steadily refusing to take the oath of allegiance to the British government, they were on the whole a peaceful and inoffensive community. But a few of the more turbulent spirits took a leading part in the Indian raids on the neighbouring British settlements, and were accused, besides, of intriguing with their countrymen at Louisburg, the strong fortress of Cape Breton. On these grounds the council at Halifax resolved upon the

## CANADA.

expulsion of the whole French population, and the measure was thoroughly carried into effect. The war in America was but a portion of the great conflict in which Britain was now engaged against France—the Seven Years' War, 1756–63. The early part of the struggle was decidedly in favour of the French, whose generals Montcalm, De Levi, and St. Veran were superior in energy and ability to their opponents Loudon and Abercrombie. But, with the appointment of Pitt as colleague of Newcastle and virtual prime-minister in 1758, the face of affairs changed. Strong reinforcements were sent out under Wolfe, Howe, and Amherst. The fortress of Louisburg, garrisoned by over 3500 soldiers and sailors, fell before Amherst, Boscawen, and Wolfe. General Johnson took Fort Niagara; Washington planted the British flag on the ramparts of Fort Du Quesne; Amherst drove the enemy from Ticonderoga and Crown Point; and the long struggle was at length virtually ended by Wolfe's brilliant capture of Quebec on 13th Sept. 1759. The French made a stand for a year longer at Montreal; but, on 8th September, 1760, the appearance of 16,000 British before its walls forced a capitulation, by which Canada passed for ever from the dominion of France.

Canada was now formally annexed to the British Empire, and in 1774 an act passed in the British Parliament (the Quebec Act) extended the bounds of the province from Labrador to the Mississippi and from the Ohio to the watershed of Hudson Bay. In 1775 the war of the American Revolution broke out, and Canada became the scene of a brief struggle between the royalists and the revolted colonists of New England. The war ended with the recognition of the independence of the American colonies by the Treaty of Versailles, September 3d, 1783, which detached from Canada the region between the Mississippi and the Ohio. On the other hand, thousands of American loyalists sought new homes in Canada; and a large number settled on the St. John River, and had that district erected into the separate province of New Brunswick. More than 10,000 settled in Ontario, where they received liberal grants of land. In 1791 Canada was divided into two provinces—Upper Canada or Ontario, and Lower Canada or Quebec—the latter still retaining its seigneurial tenure and French law in civil cases. In Upper Canada British law and freehold tenure

were introduced. In both Upper and Lower Canada representative institutions, although not responsible government, were established. From 1812 to 1815 war having broken out between Great Britain and America, Canada was again the theatre of a bloody strife, amongst the chief incidents of which were Brock's victory over the Americans on the heights of Queenstown, and the battles of Chippewa, Lundy's Lane, Moravian's Town, &c. In 1837–38 the discontent of the people of Lower Canada with their system of irresponsible government took the form of a rebellion, which was repressed after a brief but sharp struggle. At the same time the failure to secure responsible government brought about an insurrection in Upper Canada under the leadership of Wm. Lyon Mackenzie, aided subsequently by a number of American filibusters, but it was quickly suppressed by the energy of the Canadian militia. The Earl of Durham was sent out as governor-general to settle affairs on a just and liberal basis, and made a report on the condition of Canada, which is one of the historical monuments of the country. The year 1839 was distinguished by the celebrated 'Boundary Dispute' between New Brunswick and the United States. After threatening preparations on both sides the quarrel was settled in 1842 by the Ashburton Treaty, which fixed the forty-fifth parallel as the boundary-line westward from the disputed territory to the St. Lawrence, and the forty-ninth parallel, from the Lake of the Woods to the Pacific, the central line of the great lakes and their connecting rivers completing the boundary. The result of the rebellion of 1837–38, and Lord Durham's report, was the reunion in 1841 of Upper and Lower Canada as one province with equal representation in the common legislature, and the practical concession on the part of the mother country of responsible government. Kingston was selected as the new seat of government, and three years afterwards Montreal. In 1848 the Parliament House at Montreal having been burned in a riot, the seat of government was removed to Toronto and Quebec alternately every four years. In 1854 the Reciprocity Treaty with America was concluded, according to which there was to be free exchange of the products of sea and land, with navigation of the St. Lawrence, the St. John, and the canals, and the use of the inshore fisheries in the British waters to the Americans and of Lake Michigan to the

Canadians. In the same year (1854) the bill for the secularization of the clergy reserve lands, originally amounting to one-seventh of the crown territory, and a bill for the abolition of seigniorial tenure in Lower Canada were passed. By the former act the principle of religious equality was practically established in Canada. In 1858 Ottawa was finally selected as the capital of Canada, the choice having been referred to the queen. During these years the population of Upper Canada or Ontario had been rapidly increasing, and now exceeded that of Lower Canada or Quebec by nearly 300,000. Under the old constitution, however, the two provinces had equal representation in the legislature. Hence a demand arose on the part of the Upper Canadians for representation by population. This demand was practically conceded in a scheme of federation of the British North-American colonies approved of by the Canadian parliament at Quebec in 1865 and forwarded to the imperial government for approbation. In 1866 the Reciprocity Treaty with the United States having expired, the government of that country practically refused to renew it except on the most disadvantageous terms for Canada. About the same time a Fenian movement against Canada, originating in the United States, began to be heard of. Gangs of desperadoes, mostly the refuse of the civil war, collected near the frontier, and ultimately crossed, occupying some villages and plundering the neighbourhood. But the prompt mustering of Canadian volunteers made the filibusters recross the frontier in some haste, to be ultimately disarmed and dispersed by United States troops.

In 1867, March 28th, the British North America act for confederation of the colonies passed the imperial parliament. It united Upper Canada or Ontario, Lower Canada or Quebec, New Brunswick, and Nova Scotia, into one territory, to be named the Dominion of Canada. Newfoundland declared against joining the confederation, but with that exception all the British territory north of the United States was gradually included within the Dominion—the Hudson Bay Company territory by purchase in 1868, British Columbia in 1871, Prince Edward Island in 1873. In 1870 an insurrection of the Red River settlers, who were under apprehensions as to how their titles to their lands might be affected by the cession of the Hudson Bay Company's rights, took

place under the leadership of Louis Riel, and had to be suppressed by a military expedition under Colonel (now Viscount) Wolseley. To reassure the settlers a part of the newly-purchased territory was erected into an independent province under the name of Manitoba, the unorganized territory beyond receiving the name of the North-western Territory. In 1871 the Washington Treaty arranged that the fisheries of both Canada and the United States should be open to each country for the next twelve years, Canada receiving a compensation, afterwards fixed at five and a half million dollars, for the superior value of its fisheries. In 1884 considerable disaffection was caused amongst the half-breeds and Indians in the Saskatchewan and Assiniboine districts on account of the difficulty of obtaining valid titles to their lands. The discontent at length took shape in an insurrection which Louis Riel was invited to head. The rebels seized the government stores at Duck Lake and induced some of the Indian tribes to co-operate with them, with the result that a massacre of settlers took place at Frog's Lake. Within a few months an expedition under General Middleton, who had under his command several thousand volunteers, suppressed the rebellion. Only the leaders were arrested. Riel was tried and executed at Regina on July 28, 1885. On 7th November of the same year the Canadian Pacific Railway (which see) was completed, being opened for through traffic the following year. Since 1883, when the Washington Treaty expired, disputes between the American and Canadian fishermen have again been frequent, and several American fishing vessels have been seized on the British North American coasts, and others prevented from buying bait. For the adjustment of the differences connected with the fisheries a joint British and American commission was instituted in 1887, the Rt. Hon. Joseph Chamberlain being appointed to act as commissioner for England, and Sir Charles Tupper for Canada. No final settlement has been arrived at. The Earl of Aberdeen became Governor-General, Sept. 18, 1893.

**Canada Balsam**, a fluid oleo-resin obtained from the balsam-fir (*Abies balsamifera*), common in Canada and the United States, and also from Fraser's balsam-fir (*A. Fraseri*) and the hemlock spruce. It is used in medicine and in making varnishes, &c.

**Canada Goose** (*Brenta canadensis*), an American wild goose 30 to 35 inches long, brownish above, lighter below, head, neck, bill, and feet black, a white patch on the cheek; breeds in the north of the continent, and migrates southwards when the frost becomes severe.

**Canada Hemp**, a perennial herb, *Apocynum cannabinum*, of the dogbane family, native of North America. It has a strong fibre used by the Indians for twine, nets, woven fabrics, &c.

**Canada Rice** (*Zizania aquatica*), a floating grass growing in lakes and sluggish streams in Canada and the northern United States, yielding a grain that forms part of the food of the Indians, and is eaten by whites also.

**Canadian Pacific Railway**, a line of railway which traverses British North America from the St. Lawrence to the Pacific. One of the conditions upon which the province of British Columbia in 1871 entered the Dominion of Canada was the construction of such a railway. Since that time more than one act had been passed empowering different companies to go on with the work. Eventually, however, it was completed, according to arrangement with the Canadian government, by a syndicate of London, Paris, and American capitalists, being opened for general traffic in June, 1886. Commencing at Montreal, the line goes on to Ottawa, thence round the north of the Great Lakes to Port Arthur at the head of Lake Superior, and thence to Winnipeg, Manitoba, thence to Stephen in the Rocky Mountains, then across British Columbia to Vancouver on the Pacific. A branch is also in process of construction to the Atlantic seaboard. The line is of great importance not only as a means of communication between Europe and Eastern Asia and Australasia, but also as a military highway binding together the great masses of the British Empire. The length of the line from Montreal to Vancouver is 2909 miles, without counting side extensions and leased lines. The imperial and Dominion governments have granted annual subsidies to a line of steamers between Vancouver and Hong-Kong and Japan.

**Canadian River**, a river of the U. States, in New Mexico, Texas, and Indian Territory, a tributary of the Arkansas; length, 900 miles.

**Canadian Turpentine**. Same as *Canada Balsam*.

**Canal**, an artificial water-course for the

transportation of goods or passengers by boats or ships, or for purposes of drainage or irrigation. The canals most familiar to ordinary readers are for navigation. These consist usually of a number of different sections, each on one level throughout its course, but differing in relative height from the others. From one section to another boats are transferred by means of *locks*, or it may be by *inclines* or *lifts*. The lock is a water-tight inclosure with gates at either end, constructed between two successive sections of a canal. When a vessel is descending, water is let into the lock till it is on a level with the higher water, and thus permits the vessel to enter; the upper gates are then closed, and by the lower gates being gradually opened, the water in the lock falls to the level of the lower water, and the vessel passes out. In ascending the operation is reversed. The *incline* conveys the vessel from one reach to another, generally on a specially-constructed carriage running on rails, by means of drums and cables. The *lift* consists of two counterbalancing troughs, one going up as the other descends, carrying the vessel from the higher to the lower level, or *vice versa*. Works of great magnitude in the way of cuttings, embankments, aqueducts, bridges, tunnels, reservoirs for water-supply, &c., are often necessary in constructing canals. Canals have been known from remote times, Egypt being intersected at an early period by canals branching off from the Nile to distant parts of the country, for purposes of irrigation and navigation. Under the Ptolemies, before the Christian era, there existed a canal between the Red Sea and the Nile. In China, also, canals were early made on a very large scale. In Holland, where the country is flat and water abundant, canals were constructed as early as the 12th century. The lock, however, was not invented until the 15th century, both the Dutch and the Italians claiming the honour. Since then Europe has been provided with numerous canals, which being connected usually with navigable rivers, give access by water to most parts of its interior. Among the numerous canals of Holland, the most important is now the great ship canal, from 200 to 300 feet wide and 23 feet deep, which connects Amsterdam with the North Sea. In France there are many canals and canalized rivers, the principal being the Canal du Midi, branching off from the Garonne at Toulouse, and falling into

the Gulf of Lyons at Narbonne, thus connecting the Bay of Biscay and Mediterranean, and three canals connecting the basins of the Rhone, Loire, Seine, and Rhine. The canals of France have a total length of 3000 miles. In Belgium there is the Ghent-Terneuzen Canal, which allows large vessels to sail to Ghent from the Scheldt estuary. The chief canals in Germany are the Ludwigs-Canal in Bavaria, connecting (through the Main and Regnitz) the Rhine and the Danube; and the Holstein Canal, connecting the North Sea and Baltic by means of the Eider. The latter will be superseded by the Great Baltic Canal for sea-going vessels, which is to be constructed at a cost of \$40,000,000, starting near the mouth of the Elbe and reaching the Baltic near Kiel. In Russia there is canal and river communication between the Caspian and the Baltic, large part of the route consisting of the Volga. In Britain one of the earliest and most celebrated is the Bridgewater Canal (1761-65), in Lancashire and Cheshire, with a length of 38 miles. In Scotland there are the Forth and Clyde Canal, 35 miles long, joining these two rivers; and the Caledonian, 60½ miles (including lakes), from the Moray Firth on the E. coast to Loch Eil on the W., passing through Loch Ness, Loch Oich, and Loch Lochy. In the British Islands there is a total length of canal of about 3000 miles, more than five-sixths being in England. The Manchester Ship Canal, a waterway for ocean-going steamers from the estuary of the Mersey, near Runcorn, to Manchester, through a few locks and partly in the beds of the Mersey and the Irwell, was begun in the latter end of 1887; estimated cost \$26,500,000. In America the most extensive undertaking of this kind is the canal connecting the Hudson with Lake Erie. It is 363 miles in length, and carries an immense traffic. In Canada the government has constructed, at great expense, the Welland Canal, uniting Lakes Erie and Ontario, and avoiding the Niagara river and its falls; and there are also other important canals. The greatest achievement in canal-making has been the Suez Canal. It is an example of a canal without locks, open at both ends to the sea, and freely supplied with sea-water. The Nicaraguan Canal to connect the A. and P. Oceans will undoubtedly be guaranteed construction by the U.S.

**Canaletto.**—1. A Venetian painter, born in 1697, whose true name was *Antonio Canale*.

He is chiefly celebrated for his pictures of Venice, and is said to have been the first to use the camera obscura for perspective, &c. He died in 1768.—2. His nephew, **BERNARDO BELOTTI**, born in 1724, who was likewise a good artist, lived in Dresden, where he was a member of the Academy of Painters, and died at Warsaw in 1780. The Canaletti developed the pictorial treatment of architecture to a very high point.

**Canandai'gua**, a beautiful lake in New York state, 15 miles long and 1 wide, with a small town of same name on its banks. Pop. in 1890, 5868.

**Can'anore**, a seaport town, Hindustan, Malabar district, presidency of Madras, chief military station of the British in Malabar. Pop. 26,386.

**Can'ara**, a maritime region of Hindustan, now partly in the Madras presidency (South Canara), and partly in the Bombay presidency (North Canara), extending along the Indian Ocean for 180 miles, with a mean breadth of 40 miles. The Bombay portion has an area of 3911 square miles and a pop. of 421,840; the Madras portion 3902 square miles and 959,514 inhabitants.

**Cana'rium**, a genus of trees, order Amyridaceæ, natives of S.E. Asia, one species of which yields damar resin.

**Cana'ry**, a wine not unlike Madeira made in the Canary Islands, chiefly at Teneriffe.

**Canary**, GRAND, or GRAN CANARIA, an island in the Atlantic Ocean, about 180 miles from the coast of Africa. It is the most fertile and important of the Canary Islands, to which it gives name. Area, 650 square miles; pop. 70,000. Canary, or Cividad de Palmas, is the capital.

**Canary-bird**, an insessorial singing bird, a kind of finch from the Canary Islands, the *Carduelis Canaria* or *Fringilla Canaria*. They were introduced into Europe 300 or 400 years ago. A large proportion of the cage canaries are really mules, produced by the interbreeding of canaries with allied species, such as the goldfinch, siskin, linnet, bull-finch.

**Canary-flower** (*Tropæolum peregrinum*), an annual climbing plant of the Indian cress family, a native of New Granada, cultivated in Europe for its showy yellow flowers.

**Canary Islands**, or CANARIES, a cluster of islands in the Atlantic, 60 or 70 miles from the N.W. coast of Africa, and belonging to Spain. They are thirteen in number, seven of which are considerable, viz. Palma, Ferro, Gomera, Teneriffe, Grand



Canary, Fuerteventura, and Lancerota. The other six are very small: Graciosa, Roca or Rocca, Allegranza, Sta. Clara, Inferno, and Lobos. All are volcanic, rugged and mountainous, frequently presenting precipitous cliffs to the sea. The principal peak is that of Teneriffe, 12,182 feet; El Cumbre in Gran Canaria is 6650 feet. The area of the whole has been estimated at 2808 sq. miles. Their fine climate and their fertility, which owes little to cultivation, justified their ancient name of *Fortunate Islands*. There are no rivers of note, though streams are not infrequent. All the islands furnish good wine, especially Palma and Teneriffe. The exports amount to £300,000 annually, and consist of cochineal, wine, raw silk, fruits, &c. Of the Guanches, the mysterious tribe who originally inhabited these islands, we know little. The islands were discovered and conquered by the Spaniards between 1316 and 1334; they then passed into the hands of the Portuguese, but were reconquered toward the end of the 15th century by the Spaniards, who extirpated the inhabitants, and now constitute the great bulk of the population. The fortified capital is Santa Cruz, and the city Laguna is the seat of the bishop (Roman Catholic). The Canaries form a Spanish province; pop. 280,974.

**Canary-seed**, the seed of the canary-grass (*Phalāris canariensis*), order Gramineæ. The seed is used as food in the Canaries, Barbary, and Italy, and is largely collected for canary-birds. It has been successfully cultivated in England and the European continent.

**Canary-wood**, the light orange-coloured wood of *Persæa indica* and *P. canariensis*, trees of the laurel family belonging to the Canaries and Madeira.

**Canas'ter** (canister), the rush basket in which S. American tobacco was packed, and hence applied to a kind of tobacco consisting of the leaves coarsely broken for smoking.

**Cancale** (kân-kâl), a seaport and bathing place, France, dep. of Ille-et-Vilaine, about 8 miles E.N.E. of St. Malo, celebrated for its oysters. Pop. about 6000.

**Cancer** (L., a crab), in astronomy, the fourth sign in the zodiac, marked thus ♋; entered by the sun on or about the 21st of June, and quitted about the 22d of July. The constellation Cancer is no longer in the sign of Cancer, but at present occupies the place of the sign Leo.

**Cancer**, or CARCINO'MA a malignant growth or structure in some part of the

human body, which can extend itself and spread to neighbouring parts, and even form again after removal, and usually causes death. Cancer is divided into *scirrhus*, *encephaloid*, *colloid*, and *epithelial cancer*. *Scirrhus cancer* is a hard, firm, incompressible, and nodulated mass, at first non-adherent to the skin and attended with little or no pain. On section it is smooth and glistening, and exudes, on pressure, a small quantity of milky-looking juice. *Encephaloid cancer* is a soft elastic tumour, less circumscribed and increasing more rapidly than the preceding. It ends in a fungous vascular ulcer, to which the term *fungus hæmatodes* has been given, and which has a great tendency to bleed. *Colloid cancer* occurs most frequently in the stomach and alimentary canal, and consists of fibres arranged so as to form *loculi*, which contain a soft viscous matter of a yellowish, grayish, or reddish colour. *Epithelial cancer*, occurring on the skin and mucous membranes, commences as a hard little tubercle, often resembling a wart, and like the other varieties ends in an ulcer with an ichorous discharge. Cancer is often a very painful disease, but in many cases is not attended with pain. No cure for it can be said to exist, though excision, if performed in time, may not be followed by a recurrence.

**Cancer**, TROPIC OF. See *Tropics*.

**Cancer Root**, or BEECH DROP, *Epiphēgus Virginiānus*, order Orobanchaceæ, an American parasitic plant, growing on the exposed root of the beech-tree. The whole plant is powerfully astringent, and the root brownish, spongy, and of a very nauseous bitter taste. It has been used in cases of cancer.

**Candahar**. See *Kandahar*.

**Can'dareen**, in Chinese money, the 100th part of a tael, which is usually about 5s. or a little more. As a weight it is equal to 5.79 grs.

**Candela'brum**, an ornamental candlestick or lamp-holder, often of a branched form. Ancient candelabra frequently display much ingenious treatment in the design, presenting columns, figures, &c., and the branches from the central shaft were often numerous. In ancient times Tarentum and Ægina were famous for their elegant candelabra. Marble, earthenware, and other materials, as well as metal, were employed in their structure, which was sometimes on a large scale.

**Can'dia** (in the Turkish language *Kirid*, from its other name *Urctc*), one of the most important islands of the Turkish Empire,

## CANDIA — CANDLE.

situated in the Mediterranean, 81 miles from the southern extremity of the Morea and 230 from the African coast, 160 miles long, 14 to 50 broad; area, 4026 square miles. High mountains, covered with forests, run through the whole length of the island in several ranges. On the north side the island declines moderately to a fertile coast, provided with good harbours; on the south side steeply to a rocky shore, with few roadsteads; and it reaches its greatest height in Psiloriti (the ancient *Ida*), 7670 feet high, and always covered with snow. Numerous springs give fertility to most of the valleys, in which, and on the declivities of the mountains, is seen a luxuriant vegetation. The air is mild; the summer is cooled by the north winds; the winter is distinguished only by showers of rain. The island might therefore supply, as formerly, a much larger population than at present with grain, wine, and oil, wool, flax, silk, and cotton, fish, honey, game, cattle, fruits, and even with metals in abundance. But agriculture is at a very low stage, while education and the amenities of civilized life are almost entirely absent. The inhabitants (estimated at 1,200,000 in ancient times, or 900,000 in the time of the Venetians) now number about 275,000, of whom 234,000 are Christians, mostly of Greek descent. Manufactures, trade, and navigation are very insignificant. Most of the harbours are silted up. The capital, Candia, the seat of the Turkish governor, has 12,000 inhabitants; Retimo, 6000; Canea, the most important place of trade, 8000.

The early history of Candia is lost in the fables of Greek mythology, in which Saturn, Zeus, and Minos are spoken of as among its kings. At one time a republic, it became the seat of the Cilician pirates till conquered by the Romans, from whose hands it passed in 823 to the Saracens, and then to the Greeks again in 962. In 1204 the Byzantine sovereign sold it to the Venetians, who held it until the second half of the 17th century, when the Turks conquered it after a desperate struggle and the siege of the capital for no less than twenty years. Insurrections against Turkish rule have more than once occurred, a formidable one fomented by Greece in 1868 was with difficulty suppressed after a tedious conflict. In 1877 another insurrection broke out, followed by a declaration of union with Greece in 1878. The inhabitants were pacified by the concession of self-government, &c., by Mukhtar

Pasha; but religious difficulties gave rise to new troubles in 1884, when the Christian notables appealed to the sultan for a Christian governor, and succeeded in securing the reappointment of Photiades Pasha for a further term of five years.

**Can'didate**, a term taken from the Latin *candidātus*, a candidate, literally a person dressed in white, because, among the Romans, a man who solicited an office, such as the prætorship or consulship, appeared in a bright white garment—*toga candida*.

**Candle**, a solid cylindrical rod of some fatty substance, with a small bundle of loosely-twisted threads placed longitudinally in its centre, used for a portable light. The chief material used for making candles is tallow, either in a pure state or in mixture with other fatty substances, as palm-oil, spermaceti, wax, &c. Paraffin candles are now made in considerable quantities also. Ordinary tallow candles are either *dipped* or *moulded*. The former, generally composed of the coarser tallow, are made by attaching a number of separate wicks to a frame and dipping the whole into a cistern of melted tallow as often as may be necessary to give the candle the required thickness. Moulded candles, as their name implies, are formed in moulds. These, made generally of pewter, are hollow cylinders of the length of the candle, and open at both ends, but provided at the upper end with a conical cap, in which there is a hole for the wick. A number of these moulds are inserted in a wooden frame or trough with their heads downwards; the wick is then drawn in through the top hole by means of a wire, and kept stretched while the moulds are filled by running melted tallow from a boiler into the trough. Considerable modern improvements have been made in the manufacture of candles. One of the most important of these consists in not employing the whole of the fatty or oily substances, but in decomposing them, and then using only the *stearine* of the former and the *palmitine* of the latter class of substances. Wax cannot be formed into candles by melting it and then running it into moulds. Instead, the wicks, properly cut and twisted, are suspended by a ring over a basin of liquid wax, which is poured on the tops of the wicks until a sufficient thickness is obtained, when the candles, still hot, are placed on a smooth walnut table, kept constantly wet, and rolled upon it by means of a flat piece of boxwood. The large wax

## CANDLEBERRY — CANELLA.

candles used in Roman Catholic churches are merely plates of wax bent round a wick and then rolled.

**Candleberry**, **CANDLEBERRY MYRTLE**, **WAX MYRTLE**, &c. (*Myrica cerifera*), a shrub, natural order Myricaceæ, growing from 4 to 18 feet high, and common in North America, where candles are made from



Candleberry or Wax-myrtle (*Myrica cerifera*).

its drupes or berries, which are about the size of peppercorns, and covered with a greenish-white wax popularly known as Blayberry tallow. The wax is collected by boiling the drupes in water and skinning off the surface. A bushel of berries yields from 4 to 5 lbs. of wax. Another plant belonging to the same genus is the sweet-gale (*Myrica Gale*), which grows abundantly in bogs and marshes in Scotland—a small shrub, with leaves somewhat like the myrtle or willow, of a fragrant odour and bitter taste, and yielding an essential oil by distillation.

**Candle-fish**, a sea-fish of the salmon family, the *Thaleichthys pacificus*, frequenting the north-western shores of America, of about the size of the smelt. It is converted by the Indians into a candle simply by passing the pith of a rush or a strip of the bark of the cypress-tree through it as a wick, when its extreme oiliness keeps the wick blazing. It is called also *Oulachon*.

**Can'dlemas**, a church feast, instituted in 492 in commemoration of the presentation of Christ in the temple and of the purification of Mary. It falls on February 2, and on this day among Roman Catholics lighted candles are carried about in procession, and all candles and tapers which are to be used in the churches during the entire year are

consecrated. In Scotland **Candlemas** is a term-day.

**Candle-nut**, the nut of *Aleurites triloba*, a tree of India, the Moluccas, Pacific Islands, &c., nat. order Euphorbiaceæ. It is about the size of a walnut, and yields an oil used for food and for lamps, while the oily kernels are also strung together and lighted as torches.

**Candlish**, **ROBERT SMITH, D.D.**, a Scottish divine, born at Edinburgh in 1807 and educated at Glasgow University. In 1828 he was licensed, and in 1834 transferred from Bonhill to St. George's, Edinburgh. In 1839 he threw himself into the conflict with the civil courts in the matter of congregational right of election and independent church jurisdiction in matters spiritual, and soon became, next to Chalmers, the most prominent leader of the 'non-intrusion' party and disruptionists of 1843. From the death of Chalmers till his own death in 1873 Candlish was the ruling spirit in the Free Church. In 1862 he was made principal of the New College, Edinburgh. He was the author of several popular books on religious subjects.

**Candy**, or **KANDY**, a city, Ceylon, near the centre of the island, 72 miles N.E. Colombo (with which it is connected by railway), in a fertile valley surrounded by finely-wooded hills. The residence of the governor at the N.E. extremity is among the finest structures in Ceylon. Other noteworthy places are the Buddhist temple called 'the palace of the tooth,' the most sacred in the Buddhist world, the old royal cemetery, the military magazine in the centre of a lake, the government brick-works, &c. Pop. 22,000.

**Candy**, an Eastern measure of weight, varying from 560 lbs. up to above 800.

**Can'dy tuft**, the popular name of several flowers of the genus *Iberis*, order Cruciferae, common in gardens: said to be named from Candia.

**Cane**. See *Bamboo*, *Rattan*, *Sugar-cane*.

**Cane'a**, or **KHANIA**, a seaport of Crete or Candia, on the N. coast, the principal mart for the commerce of the island in wax, soap, oil, silks, fruits, wool, and provisions. Pop. 8000.

**Canella**, **WHITE** (*C. alba*), a tree belonging to the West Indies, growing to the height of 10 to 50 feet, with a straight stem branched only at the top. It is covered with a whitish bark, which is freed from its outward covering, dried in the shade, and brought to Europe in long quills, somewhat thicker than those of cinnamon. It is moderately

warm to the taste, and is esteemed as a pleasing and aromatic bitter.

**Canephorus**, one of the bearers of the baskets containing the implements of sacrifice in the processions of the Dionysia,



Canephorus, from terra cotta in British Museum.

Panathenea, and other ancient Grecian festivals, an office of honour much coveted by the virgins of antiquity. The term is applied to architectural figures bearing baskets on their head, sometimes improperly confounded with Caryatides.

**Canes Venatici** (kā'nēz vē-nat'i-sī; 'the hunting dogs'), a northern constellation, within the limits of which several remarkable nebulae occur.

**Cang**, **CANGUE**, or **KEA**, the wooden collar, weighing from 50 to 60 lbs. and fitting closely round the neck, imposed upon criminals in China.

**Canicat'ti**, a town in Sicily, province of Girgenti, well built, and with a pop. of 19,679, mostly engaged in agriculture.

**Canic'ula**, the dog-star or Sirius; hence *Canicular days*, the dog-days.

**Can'idæ**, the dog family of animals.

**Canino**, **PRINCE OF**. See *Bonaparte* (*Lucien*).

**Ca'nis**, the genus of animals to which the dog, wolf, and fox belong.

**Canis Major** ('the greater dog'), a constellation of the southern hemisphere, remarkable as containing *Sirius*, the brightest star. — **CANIS MINOR** ('the lesser dog') is a constellation in the northern hemisphere, immediately above *Canis Major*, the chief star in which is *Procyon*.

**Canister Shot**. Same as *Case-shot*.

**Canker**, (1) in medicine, a collection of small sloughing ulcers in the mouth, especially of children; called also water canker. (2) In horticulture, a kind of gangrenous disease to which fruit-trees especially are liable, beginning in the younger shoots and gradually extending to the trunk. (3) In farriery, a disease in horses' feet causing a discharge of fetid matter from the cleft in the middle of the frog, generally originating in a diseased thrush.

**Canker-worm**, a worm or larva destructive to trees or plants; in America specifically applied to moths and larvæ of the genus *Anisopteryx*.

**Canna**, a genus of plants, order Marantaceæ, some species of which have fine flowers, and some from their black, hard, heavy seeds are called Indian shot.

**Cannabina'ceæ**, the order of plants to which only two plants, hemp (genus *Cannabis*) and the hop, belong, closely allied to the nettle order.

**Cannæ**, a town of S. Italy, province of Bari, near the mouth of the Ofanto, formerly the Aufidus, famous as the scene of the great battle in which the Romans were defeated by Hannibal (216 B.C.) with immense slaughter.

**Can'nanore**. See *Cananore*.

**Cannel Coal**. See *Coal*.

**Cannes** (kân), a seaport of France, on the shore of the Mediterranean, dep. Alpes-Maritimes; famous as a winter residence, and as the place where Napoleon landed when he returned from Elba, March 1, 1815. Pop. 19,385.

**Cannibalism**, or **ANTHROPOPHAGY**, the eating of human flesh as food, a practice that has been known from the earliest times, and in the most widely spread localities. See *Anthropophagi*.

**Canning**, **CHARLES JOHN, EARL**, son of George Canning, born in 1812; educated at Eton and Oxford. In 1841 he was appointed under-secretary of state for foreign affairs in Peel's government, and in 1846 commissioner of woods and forests. In the Aberdeen ministry of 1853, and under Palmerston in 1855, he held the postmaster-generalship, and in 1856 went out to India as governor-general. Throughout the mutiny he showed a fine coolness and clear-headedness, and though his carefully-pondered decisions were sometimes lacking in promptness, yet his admirable moderation did much to re-establish the British Empire in India.

He was raised to the rank of earl and made viceroy, but returned to England with shattered health in 1862, dying in the same year.

**Canning, GEORGE**, a distinguished orator and statesman, born in London in 1770; educated at Eton and at Oxford. He was first brought into parliament by Pitt in 1793, and in 1796 became under-secretary of state. In 1797 he projected, with some friends, the *Anti-Jacobin*, of which Gifford was appointed editor, and to which Canning contributed the *Knife-grinder* and other poems and articles. In 1798 he sup-

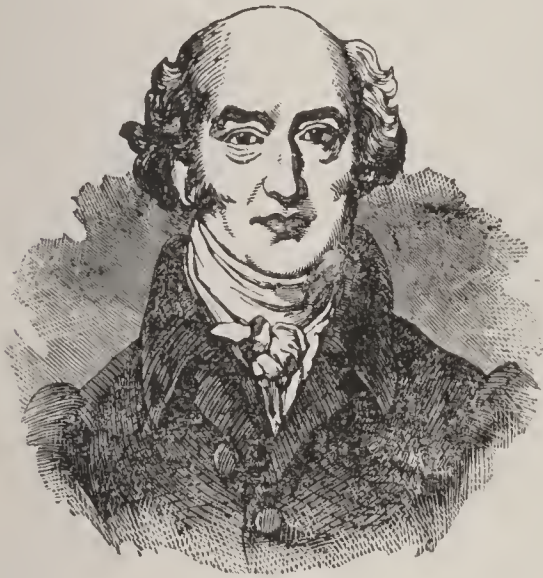

George Canning.

ported Wilberforce's motion for the abolition of the slave-trade. In 1807 he was appointed secretary of state for foreign affairs in the Portland administration, and was slightly wounded in a duel with Lord Castlereagh arising out of the dispute which occasioned the dissolution of the ministry. In 1810 he opposed the reference of the Catholic claims to the committee of the whole House, on the ground that no security or engagement had been offered by the Catholics, but supported in 1812 and 1813 the motion which he had opposed in 1810. In 1814 he was appointed minister to Portugal, and remained abroad about two years. He refused to take any part in the proceedings against the queen, and in 1822, having been nominated Governor-general of India, he was on the point of embarking when the death of Castlereagh called him to the cabinet as foreign secretary. One of his earliest acts in this situation was to check the French influence in Spain. He continued to support the propositions in favour of Catholic emancipation, arranged the

triple alliance for the preservation of Greece, but opposed parliamentary reform and the Test and Corporation Acts. April 12, 1827, his appointment to be prime-minister was announced, but his administration was terminated by his death on the 8th of August following. On all the leading political questions of his day, with two exceptions—the emancipation of the Catholics and the recognition of the South American republics—he took the high Tory side.

**Canning, STRATFORD, VISCOUNT STRATFORD DE REDCLIFFE**, an English diplomatist, son of a London merchant and cousin of George Canning, born in 1788. He entered the diplomatic service in 1807, and in 1820 became plenipotentiary at Washington. In 1824 he went as ambassador extraordinary to St. Petersburg, and afterwards to Constantinople about the Greek difficulty; but negotiations were broken off by the battle of Navarino. He was sent again to Constantinople in 1831, and to Spain in 1832, and from 1834 to 1841 sat in parliament for King's Lynn. In 1842 he became ambassador at Constantinople, a post held by him for sixteen years under varying ministries with high honour. In 1852 he was raised to the peerage, and in 1869 created knight of the Garter. He retired from diplomatic work in 1858, but exercised no small influence in the House of Lords, and as late as 1880 drew up a paper on the Greek claims. He died in the August of that year, having done more than any one man to establish British prestige in the East.

**Can'nock**, a town of England, in Staffordshire,  $7\frac{1}{2}$  miles N.W. of Walsall, with coal-mines, &c. Pop. 20,613. Near it is Cannock Chase, a tract of 3600 acres.

**Cannon**, a big gun or piece of ordnance. The precise period at which engines for projecting missiles by mechanical force (catalpults, &c.) were supplanted by those utilizing explosive materials is a matter of controversy, the invention of cannon being even attributed to the Chinese, from whom the Saracens may have acquired the knowledge. A doubtful authority asserts their use at the siege of Belgrade in 1073; but they were certainly brought into use in France as early as 1338. At first they were made of wood, well secured by iron hoops, the earliest shape being somewhat conical, with wide muzzles, and afterwards cylindrical. They were then made of iron bars firmly bound together with iron hoops like casks, Mons

## CANNON.

Meg at Edinburgh being a good example. Bronze was used in the second half of the 14th century, towards the close of which and during the 15th century cast-iron ordnance came into use. A form of breech-loading cannon was introduced in the 16th century. Cannon were formerly dignified with great names. Twelve cast by Louis XII. were called after the twelve peers of France, and Charles V. had twelve called after the twelve apostles. Later such names as the following came into general use: cannon royal, or carthoun, carrying 48 pounds; culverin, 18; demi-culverin, 9; falcon, 6; basilisk, 48; siren, 60; &c. Cannon were then named from the weight of the balls which they carried: 6-pounders, 12-pounders, &c.; but are now usually, especially the large ones, designated by their weight, as a 25-ton gun, an 80-ton, &c. Their calibre or diameter of bore is also used in designating them.

Great improvements and changes in the manufacture of cannon have been introduced in recent times. Not so long ago they were all made of iron, brass, or gun-metal (a variety of bronze) by casting. The introduction of rifled small-arms led the way to that of rifled cannon, and the adoption of heavy armour for ships of war rendered guns of enormous power and magnitude necessary in order to penetrate their sides. The increased inertia of the projectiles and their rapid rotation in these rifled guns tried the piece so severely that cast-iron and even bronze have been largely superseded and the old method of making guns given up. Those that are now made of bronze have often their bore widened by strong cylinders of steel successively forced into them, a process which condenses and hardens the surrounding bronze, giving it a tenacity approaching that of cast-steel. Compound guns, built up in different ways, have found favour where abundant means of manufacture existed. In England steel and wrought-iron guns have come in for all heavy artillery, and they have been manufactured for foreign powers on a large scale, especially by the Elswick Ordnance Company. The heavy guns of the British service, made on the 'Woolwich' system, have a steel tube to form the bore, over which are shrunk coils of wrought iron, increasing in thickness about the breech. This method of manufacture was first introduced by Sir W. (now Lord) Armstrong about 1858. This construction presents the

hard steel to meet the wear and tear on the bore of the gun, while great support is given by shrinking on the wrought-iron hoops, which contract with a tight grip upon the steel. The fibre of the wrought-iron winding round the barrel in a helix is applied in the best direction to give tensile strength. Hoops of Bessemer steel have latterly been preferred to those of wrought iron; and still more recently the breech has been strengthened by steel wire or a ribbon of steel coiled round it. Steel guns of very high quality have been made by Krupp of Essen and Sir J. Whitworth, and have also been manufactured in Russia. The Whitworth guns are cast of mild steel of a special quality. In them massive hoops are forced over a central tube, and over one another, by shrinkage or by hydraulic pressure. These guns have comparatively small hexagonal bores, with a very rapid twist, and fire long projectiles made to fit mechanically with remarkable accuracy to a great range. In America enormous cast-iron smooth-bore guns have been made on the Rodman system, throwing very heavy spherical projectiles at a low velocity, intended by their great weight to bend and open armour at the joints, thus destroying the vessel by what is termed 'racking.' But the common system is to punch holes in the armour by means of rather smaller projectiles, made of chilled iron, which strike at a high velocity, and the range and penetration of modern ordnance are something enormous. Thus some of the larger guns are sighted for 5 miles, and they can penetrate 30 inches of armour at the distance of 1000 yards. Eighty-ton, 100-ton, and 110-ton guns have been constructed for the British navy and land defences, and the Italian navy has been supplied with several 100-ton and even larger guns. A British 80-ton gun throws a projectile of 1700 lbs. in weight, a 100-ton gun one of about 2000 lbs. in weight.

Rifled cannon load either at the muzzle or breech. The former system is simpler and stronger. The latter facilitates loading and exposes the gunners less to the fire of the enemy's riflemen, especially when the gun is firing through a ship's port or the embrasure of a fort. In England Lord Armstrong first achieved marked success with breech-loading guns; Sir J. Whitworth also produced a notable breech-loader. The German firm of Krupp is especially celebrated for very large breech-loading guns. The British service system for guns of all

calibres was till lately a muzzle-loading one, but a new type of breech-loading ordnance of steel has recently been adopted by the authorities. The projectiles for rifled guns are not spherical, but elongated, their length being perhaps  $2\frac{1}{2}$  or 3 times their diameter; they usually have a flanged copper disc fitted on to the base, and the pressure of the gas when the charge is exploded forces out the flanges into the grooves. Among recent improvements may be mentioned the use of a 'powder chamber' of greater diameter than the rest of the bore, and the adoption of an increased twist in the rifling instead of a uniform one. Guns for firing charges of dynamite or other powerful explosive have recently been experimented with. The American 8 and 10-inch all steel breech-loading rifles have projectiles that are unsurpassed. Experiments made Oct. 5, 1893, at the Sandy Hook proving-ground, were successful, as follows: the 8-inch gun fired three 300-pound conical steel projectiles, piercing perfect round holes through a 9-inch open-hearth steel plate, forged, tempered, and annealed, weighing 24,660 pounds, travelling afterward over one-fourth of a mile. The 10-inch gun fired two 575-pound projectiles, piercing an 11 $\frac{1}{4}$ -inch steel plate, weighing 43,779 pounds, going afterward a considerable distance. In neither of the experiments was any mark left on the projectiles. See also *Gun-carriage, Artillery, Mortar, Howitzer, Shell, &c.*

**Ca'no**, ALONSO, a painter, sculptor, and architect, who has been called the Michael Angelo of Spain, born in 1601 at Granada. He first made himself known by his statues for the great church of Lebrija, and was in 1638 appointed painter to the king. His wife having been murdered by a servant or pupil, he was suspected and put to torture; but his right arm was spared from respect for his talents. He afterwards became a priest, and was made a *racionero* (resident) of Granada, where he passed the remainder of his life, dying in 1664 or 1667.

**Canoe** (ka-nö'; through the Spanish *canoá*, from the native West Indian name), a light boat narrow in the beam, and adapted to be propelled by paddles, often in conjunction with sails. The name was originally given to the boats of uncivilized races, but its application has been considerably extended, and canoes of home make may be seen on the waters of the most civilized countries. They are of the most

diverse materials and construction. Often they are hollowed out of a single log. The Indian canoes of Canada are of bark on a wooden frame. The Esquimaux *kaiaks* consist of a light wooden frame, covered with seal-skins sewed together with sinews, and having only one opening to admit the boatman to his seat. In the islands of the Pacific the natives have double canoes, united by a strong platform, serving in this way as one vessel.

**Can'on** (Gr. *kanōn*, a rule, measure, or standard), a term given collectively to the books of the Holy Scriptures universally received as genuine by Christian churches. See *Bible, Apocrypha*.

**Can'on**, a church dignitary who possesses a prebend, or revenue allotted for the performance of divine service in a cathedral or collegiate church. Canons were formerly divided into canons *regular*, or those living a monastic life, and canons *secular*, those not so living. In England, besides the ordinary canons—who with the dean form the *chapter*—there are honorary canons and minor canons; the latter assist in the daily choral service of the cathedral. Of course these are all secular.

**Can'on**, in music, a composition in which the several voices begin at fixed intervals, one after the other, and in which each successive voice sings the strain of the preceding one. Finite canons, like ordinary compositions, end with a cadence, while infinite canons are so contrived that the theme is begun again before the parts which follow are concluded.

**Cañon** (kan-yon'), the Spanish word for tube, funnel, *cannon*; applied by the Spanish Americans, and hence in N. America generally (often with the spelling *Canyon*), to long and narrow river gorges or deep ravines with precipitous and almost perpendicular sides occurring frequently in the Rocky Mountains, the Sierra Nevada, and great western plateaus of N. America. See illustration under *Arizona*.

**Canoness**, a lady holding a similar position to a canon. Canonesses still exist in Germany.

**Canonical Books**, the books of Scripture belonging to the *canon*. See *Canon*.

**Canonical Hours**, certain stated times of the day appropriated by ecclesiastical law to the offices of prayer and devotion in the Roman Catholic Church, viz.: matins with lauds, prime, tierce, sext, nones, evensong or vespers, and compline.

**Canonicals**, the dress or vestments of the clergy.

**Canonization**, a ceremony in the Roman Church, by which deceased persons are declared saints. The pope institutes a formal investigation of the miraculous and other qualifications of the deceased person recommended for canonization; and an *advocate of the devil*, as he is called, is appointed to assail the memory of the candidate. If the examination is satisfactory, the pope pronounces the beatification of the candidate, the actual canonization generally taking place some years afterwards, when a day is dedicated to his honour, his name inserted in the *canon* or Litany of the Saints in the Mass, and his remains preserved as holy relics.

**Canon Law**, a collection of ecclesiastical constitutions for the regulation of the Church of Rome, consisting for the most part of ordinances of general and provincial councils, decrees promulgated by the popes with the sanction of the cardinals, and decretal epistles and bulls of the popes. There is also a canon law for the regulation of the Church of England, which under certain restrictions is used in ecclesiastical courts and in the courts of the two universities. In the Roman Church these collections came into use in the 5th and 6th centuries. The chief basis of them was a translation of the decrees of the four first general councils, to which other decrees of particular synods and decretals of the popes were added. In the time of Charlemagne the collection of Dionysius the Little acquired almost the authority of laws. Equal authority, also, was allowed to the spurious 9th-century collection of decretals falsely ascribed to Isidore, Bishop of Seville. After the 10th century systematical compendiums of ecclesiastical law began to be drawn from these canons, the most important being that of the Benedictine Gratian of Chiusi, finished in 1151. Within ten years after its appearance the Universities of Bologna and Paris had their professors of canon law, who taught from Gratian's work, which superseded all former chronological collections. After the appearance of the *Decretum Gratiani*, new decrees of councils and new decretals were promulgated, which were collected by Raymond of Pennaforte under the name of *Decretales Gregorii Noni* (1234); and the later decretals, &c., collected by Boniface VIII., were published as the sixth book of the Gregorian Decretals

in 1298, all these having the authority of laws. Pope Clement V. published a collection of his decrees in 1313. About the year 1340 the decretals of John XXII. were published (*Extravagantes Johannis XXII.*); and at a later period the subsequent decretals, to the time of Sextus IV. (*Extravagantes Communes*) appeared. These *Extravagantes* have not altogether the authority of law. Under Pope Pius IV. a commission was appointed to revise the *Decretum Gratiani*, the work being completed under Gregory XIII., and sanctioned by bull in 1580. The authority of the canon law in England, since the Reformation, depends upon the statute 25th Henry VIII., according to which such ecclesiastical laws as were not repugnant to the laws of the realm and the king's prerogative were to remain in force till revised. This revision was never made. A body of 141 canons was drawn up for the English church in 1603-4, and these are still partially in force, so far as concerns the clergy.

**Canop'ic Vases**, vessels found in Egypt, which were placed in tombs, and contained the embalmed intestines of the dead.

**Cano'pus**, an ancient Egyptian city, between Alexandria and the western mouth of the Nile, once the chief harbour of the Delta. It had a popular temple of Serapis.

**Can'opy**, a raised and ornamental covering above a throne, a bed, or the like; in architecture, a decorative structure serving as a hood or cover above an altar, pulpit, niche, &c.

**Cano'sa** (the ancient *Canusium*), a city of South Italy, province of Bari, famous for the rock-cut tombs in its vicinity, from which many rare antiquities have been obtained, vases, weapons, ornaments, &c. Pop. 14,458.

**Cano'va**, ANTONIO, an Italian sculptor, born in 1757 at Possagno, in Venetian territory. He was first an apprentice to a statuary in Bassano, from whom he went to the Academy of Venice, where he had a brilliant career. In 1779 he was sent by the senate of Venice to Rome with a salary of 300 ducats, and there produced his *Theus* and the *Slain Minotaur*. In 1783 Canova undertook the execution of the tomb of Pope Clement XIV. in the Church of the Apostles, a work in the Bernini manner, and inferior to his second public monument the tomb of Pope Clement XIII. (1792) in St. Peter's. From 1783 his fame rapidly increased. He established a school



for the benefit of young Venetians, and amongst other works produced his group of Venus and Adonis, the Psyche and Butterfly, a Repentant Magdalene, the well-known Hebe, the colossal Hercules hurling Lichas into the Sea, the Pugilists, and the group of Cupid and Psyche. In 1796 and 1797 Canova finished the model of the celebrated tomb of the Archduchess Christina of Austria, and in 1797 made the colossal model of a statue of the King of Naples executed in marble in 1803. He afterwards executed in Rome his Perseus with the Head of Medusa, which, when the Belvidere Apollo was carried to France, was thought not unworthy of its place and pedestal. In 1802 he was invited by Bonaparte to Paris to make the model of his colossal statue. Among the later works of the artist are a colossal Washington, the tombs of the Cardinal of York and of Pius VII.; a Venus Rising from the Bath; the colossal group of Theseus Killing the Minotaur; the tomb of Alfieri; the Graces Rising from the Bath; a Dancing Girl; a colossal Hector; a Paris, &c. After the second fall of Napoleon, in 1815, Canova was commissioned by the pope to demand the restoration of the works of art carried from Rome. He went from Paris to London, and returned to Rome in 1816, where he was made Marquis of Ischia, with a pension of 3000 scudi. He died at Venice, Oct. 13, 1822.

**Canrobert** (kân-ro-bâr), FRANÇOIS CERTAIN, French marshal, born 1809. He commanded in the Crimean war under St. Arnaud, and after his death received the chief command, but could not work in harmony with the British and made way for Pélissier. In the Italian war (1859) he commanded the 3d division, and distinguished himself at Magenta. In the Franco-German war he belonged to the force that was shut up in Metz and had to capitulate. He has latterly been a French senator. Died in 1895.

**Can'so**, GUT or STRAIT OF, a narrow strait or channel, about 17 miles long, separating Nova Scotia from Cape Breton Island.

**Cantabile** (kan-tab'i-le), in music, a term applied to movements intended to be performed in a graceful, elegant, and melodious style.

**Can'tabri**, the rudest and most valiant of all the old Iberian tribes anciently inhabiting the northern mountains of Spain.

**Canta'brian Mountains**, the general name of the various mountain ranges extending

from the Western Pyrenees along the N. coast of Spain to Cape Finisterre.

**Cantacuze'nus**, JOHN, a Byzantine emperor and historian, born about 1300. He was minister of Andronicus III., on whose death he became regent during the minority of John Palæologus. He defeated the Bulgarians and Turks, assumed the diadem, and entered Constantinople in triumph in 1346. After an honourable reign he retired to a monastery (1355), where he employed himself in composing a Byzantine history and other works, chiefly theological.

**Cantal'**, a central department in France, area 2217 square miles; capital, Aurillac. This department, formerly part of Upper Auvergne, is named from its highest mountain, the Plomb du Cantal, 6094 ft. in height. The greater part of it, occupied by the Cantal Mountains and high lands, furnishes only timber, archil, and pasture. It is watered by numerous rivers, the principal of which are the Dordogne, Cère, and Lot. The principal crops are rye, buckwheat, potatoes, and chestnuts, hemp and flax. Cattle, sheep, pigs, horses, and mules are reared in large numbers. Large quantities of cheese ('Auvergne cheese') are made. Hot mineral springs are abundant. Pop. 1891, 239,601.

**Can'taliver**, CANTILEVER, a wooden or iron block framed into the wall of a house and projecting from it to carry mouldings, eaves, balconies, &c. Also a large projecting framework forming part of an iron bridge directly carrying part of the roadway, and also supporting beams or girders bridging over a space between it and another similar structure.

**Can'taloupe** (-löp), a small round variety of musk-melon, globular, ribbed, of pale-green or yellow colour, and of delicate flavour; first grown in Europe at the castle of Cantaloupe.

**Can'taro**, a measure of weight and capacity; in Turkey 125 lbs., in Egypt 98 lbs., in Malta 175 lbs., &c. The Spanish wine measure cantaro is about 3½ gallons.

**Cantata** (kan-tä'ta), a vocal composition, consisting of an intermixture of air, recitative, duet, trio, quartette, and chorus, often taking the form of a short oratorio or unacted opera.

**Canteen'** (Ital. *cantina*, a wine-cellar), in military language, a regimental establishment managed by a committee of officers, in British barracks or forts, for the sale of liquors, tobacco, groceries, &c., to the sol-

## CANTERBURY — CANTON.

diers at reasonable prices. The profits are employed for the benefit of the soldiers themselves.

**Can'terbury**, a city and parl. and municipal borough of England in Kent, 55 miles S.E. of London, giving name to an archiepiscopal see, the occupant of which is primate of all England. The Roman name was *Durovernum*, and the place was of early importance. Its present name is a modification of the Saxon *Cant-wara-byrig*, the Kentishmen's city. The foundation of the archiepiscopal see took place soon after the arrival of St. Augustine in 596. In the 8th, 9th, 10th, and 11th centuries the city was dreadfully ravaged by the Danes, but at the Conquest its buildings exceeded in extent those of London. The ecclesiastical importance of the place was consummated by the murder of Thomas à Becket in the cathedral, the priory and see benefiting by the offerings of devotees and pilgrims at his shrine. Henry VIII. dissolved the priory in 1539, and ordered the bones of Becket to be burned; and the troopers of Oliver Cromwell made a stable of the cathedral.—The town is beautifully situated in a fertile vale, on the river Stour. Small portions of the old walls and one of the old gates still remain. The cathedral, one of the finest ecclesiastical structures in England, 530 feet in length and 154 in breadth, has been built in different ages, the oldest part dating from about 1174. The great tower, 235 feet in height, is a splendid specimen of the Pointed style. Other ecclesiastical buildings are St. Augustine's monastery, now a Church missionary college, St. Margaret's church, and the church dedicated to St. Martin, believed to be one of the oldest existing Christian churches. The old archiepiscopal palace is now represented by a mere fragment, and the archbishops have long resided at Lambeth. Canterbury has a royal grammar-school, founded by Henry VIII., numerous other schools, art gallery, &c. There are breweries and malting establishments; and the principal articles of trade are corn and hops. There are extensive barracks for cavalry and infantry. It returns one member to parliament. Pop. 1891, 23,026.

**Canterbury**, a district occupying most of the centre of South Island, New Zealand, with a coast-line of 200 miles, and a greatest breadth of about 150 miles. The western part is traversed by mountains, from which a fertile plain of 2,500,000 acres slopes gra-

dually down to the sea. Banks' Peninsula is a projection on the E. coast, consisting of an assemblage of densely-wooded hills, and containing several harbours. The famous 'Canterbury Plains,' extending along the coast, are admirably adapted for agriculture, while the interior is fine pastoral country, though, except near the highlands, very destitute of trees. Its considerable mineral resources are as yet not well developed, though some coal—of which there are large beds—is raised. The chief places in the province are Christchurch, the capital; and Lyttelton, the port town, 8 miles from Christchurch. Pop. 1891, 128,392.

**Canterbury-bell**, a name given to species of *Campanula*, *C. medium* and *C. trachelium*. See *Campanula*.

**Canthar'ides**, or SPANISH FLY (*Cantharis* or *Lytta vesicatoria*), a kind of beetle common in Spain, Italy, and France, having the body from 6 to 10 lines long, and of a golden-green colour. It lives on trees, the leaves of which it eats. When bruised these insects are extensively used as the active element in vesicatory or blistering plasters, and internally in certain cases. Their use is very dangerous, and care must be exercised even in collecting them. Their active properties they owe to *cantharidin* ( $C_5H_6O_2$ ), an energetic poison.

**Canticles**. See *Solomon's Song*.

**Cantilever**. See *Cantaliver*.

**Cantire**. See *Cantyre*.

**Canto Fermo**, plain-song or choral song in unison or octave and the notes all of one length; the grave measured chant of the ancient church.

**Canton**, a thriving town, Fulton county, Ills., 50 miles N. W. of Springfield, centre of a coal and manufacturing district. Pop. in 1890, 5604.

**Canton** (Chinese *Quang-chow-foo*), a large and important city of Southern China, 80 miles from the sea, on the Pearl River (here about the width of the Thames at London Bridge), in the province of Quang-tung (of which name *Canton* is a corruption). The city proper is inclosed by walls 25 feet high and 20 feet thick, forming a circuit of six miles, with 12 gates; and it is divided into two parts by a wall running east and west; the larger portion north of this wall being called the old, that on the south of it the new city. The streets are long, straight, and in general paved, but very narrow, and gaudy with painted signs. The houses of the poorer

## CANTON — CANVAS.

classes are mere mud hovels; those of the shop-keeping class are commonly of two stories, the lower serving as the shop. The foreign mercantile houses, and the British, French, and American consulates, have as their special quarter an area in the suburbs in the south-west of the city, with water on two sides of it. In the European quarter are churches, schools, and other buildings in the European style. The river opposite the city for the space of four or five miles is crowded with boats, a large number of which—as many it is said as 40,000—are fixed residences, containing a population of 200,000. The industries of Canton are varied and important, embracing silk, cotton, porcelain, glass, paper, sugar, lackered ware, ivory carving, metal goods, &c. It was the chief foreign emporium in China until 1850, when Shanghai began to surpass and other ports to compete with it but its exports and imports together often still amount to about \$40,000,000. Since the establishment of the colony of Hong-Kong a flotilla of river steamers ply daily between Canton, Hong-Kong, and Macao. In 1856 the foreign factories were pillaged and destroyed by the Chinese, and about a year after this Canton

was taken by an English force, and occupied by an English and French garrison until 1861. Pop. estimated at over 1,600,000.

**Canton'**, a city of the U. States, in Ohio, with various industrial establishments. Pop. 1890, 26,189.

**Can'ton**, a small division of territory constituting a distinct state or government, as in Switzerland.

**Canton'ments**, the places in which troops are quartered when they are detached and distributed over a number of towns and villages, with facilities for concentration. In India the permanent military stations erected in the neighbourhood of the principal cities are so called.

**Can'tor**, the leader of the singing in a cathedral; a precentor.

**Cantyre** (kan-tir'), or KINTYRE, a peninsula, Scotland, between the Firth of Clyde and the Atlantic, forming the southern division of Argyleshire. It is 40 miles long from the isthmus of Tarbet to the Mull of

Cantyre in the s.w., and has an average breadth of about 7 miles.

**Canute**, or Cnut (ka-nūt', knūt), King of England and Denmark, succeeded his father Swegen or Sweyn on his death in England in 1014 A.D., and confirmed the Danish power in England. He began by devastating the eastern coast, and extended his ravages in the south, where, however, he failed to establish himself until after the assassination of Edmund Ironside, when



he was accepted king of the whole of England (1017). Canute, who began his reign with barbarity and crime, afterwards became a humane and wise monarch. He restored the English customs at a general assembly, and ensured to the Danes and English equal rights and equal protection of person and property, and even preferred English subjects to the most important posts. His power was confirmed by his marriage with Emma, Ethelred's widow. At Harold's death in 1018 he gained Denmark; in 1028 he conquered Norway; and in 1031 he made Malcolm of Scotland admit his superiority. Sweden also was vassal to him. He died in 1036 at Shaftesbury, leaving Norway to his eldest son, Sweyn; to the second, Harold, England; to the third, Hardicanute, Denmark.

**Can'vas**, a coarse and strong cloth, made of flax or hemp, and used for sails, tents, &c. When prepared for portrait-painting it is classed as *kit-cat*, 28 by 36 inches;

## CANVAS-BACK DUCK — CAPE COAST CASTLE.

*three-quarters*, 25 by 30; *half-length*, 40 by 50; *bishop's half-length*, 44 or 45 by 56; *bishop's whole length*, 58 by 94.

**Canvas-back Duck** (*Fuligula* or *Nyroca vallisneria*), a bird peculiar to N. America, and considered the finest of the water-fowl for the table. They arrive in the United States from the north about the middle of October, sometimes assembling in immense numbers. The plumage is black; white, chestnut-brown, and slate colour; length about 20 inches.

**Canzone** (kan-tsō'nā), a kind of lyric poem in several stanzas, of Provençal origin, reduced to method in the Italian poetry of the 13th century. There are several varieties of it.

**Can'zonet**, CANZONETTA, in Italian poetry a canzone with short verses, much used in the 15th century. In music, *canzonet* originally signified a short song in parts, but has often been loosely applied to any trifling air.

**Caoutchouc** (kō'chök or kou'chök), an elastic gummy substance, chemically a hydrocarbon, contained in the milky juice of a number of tropical trees of various orders, among the chief being the *Siphonia elastica* (*Hevëa elastica*) and others of the same genus growing in South America. The name is also used as an equivalent of india-rubber, but strictly caoutchouc is only the chief ingredient of india-rubber. The crude india-rubber is most commonly obtained by making incisions in the trunks of the trees, whence the sap exudes in the form



Caoutchouc Tree (*Siphonia elastica*).

of a milky fluid which gradually thickens and solidifies. Caoutchouc is a non-conductor of electricity and a bad conductor of heat. It is not dissolved by water, hot or cold, but chloroform, oil of turpentine, bisulphide of carbon, &c., dissolve it. It was not until about the year 1736 that

india-rubber was known in Europe. It was at first only used to rub out pencil-marks, but before the end of last century it was used to render leather and other substances water-tight, and in 1823 Macintosh took out a patent for the waterproof materials prepared with caoutchouc which bear his name. Latterly its uses have become innumerable. Gutta percha is a similar substance to caoutchouc, and is often popularly confounded with it. See *India-rubber*.

**Cap**, in ships, a strong piece of timber placed over the head or upper end of a mast, having in it a round hole to receive the top or top-gallant masts, which are thus kept steady and firm.

**Cap**, a covering for the head, usually of softer materials and less definite form than a hat. *Cap of maintenance*, a cap formerly worn by dukes and commanders in token of excellency, now an ornament of state carried before the sovereigns of England at their coronation, and also before the mayors of some cities.



Cap of Maintenance, from great seal of Henry VII.

**Cape Breton**, an island of the Dominion of Canada, separated from Nova Scotia, to which province it belongs, by the narrow Gut or Strait of Canso; area 3120 sq. miles. It is of very irregular shape, the Bras d'Or, an almost landlocked arm of the sea (with most picturesque scenery), penetrating its interior in various directions, and dividing it into two peninsulas connected by an isthmus across which a canal has been cut. The surface is rather rugged, and only small portions are suited for agriculture; but it possesses much timber, valuable minerals (several coal-mines being worked), and the coast abounds in fish. Timber, fish, and coal are exported. The island belonged to France from 1632 to 1763, and Louisburg, its capital, was long an important military post. It was separate from Nova Scotia between 1784 and 1820. Chief town, Sydney. Pop. of Cape Breton, 84,500.

**Cape Coast Castle**, a town and fort in West Africa, capital of the British possessions on the Gold Coast. The fortress stands on a rock close to the sea; the town chiefly consists of mud huts, and is a mart for native barter. Climate unhealthy; principal exports, gold-dust, ivory, and palm-oil. Pop. 10,000.

**Cape Cod**, a noted peninsula of the United States on the s. side of Massachusetts Bay; 65 miles long and from 1 to 20 broad. It is mostly sandy and barren, but populous.

**Cape Colony**, a British colony occupying the southern extremity of Africa, washed on the west, south, and east by the ocean, and bounded on the north by German territory, Bechuanaland, Orange River State, Natal, &c., the Orange River forming a great part of the boundary. Area (with dependencies), 221,311 sq. miles; pop. (1891), 1,527,224. The coast is not much indented; the principal bays are St. Helena, Saldanha, Table, False, Walker, Mossel, and Algoa. In the interior almost every variety of soil and surface is found, but a great part of the colony is arid and uninviting in appearance. Several ranges of mountains, running nearly parallel to the southern coast, divide the country into successive terraces, rising as they recede inland, between which lie belts of fertile land, or vast barren-looking plains, one of them, the Great Karroo, being 300 miles long and 100 broad. These plains make valuable sheep-walks, and the soil, where there is a sufficiency of water, is generally fertile. Irrigation, however, is greatly required, and large reservoirs are now being constructed. The principal and furthest inland mountain terrace, averaging 6000 or 7000 ft. in height, commences in Namaqualand and runs to the north-east frontier. The culminating point is the Compass Berg, over 8000 ft. The Table Mountain at Cape Town rises almost perpendicularly about 3585 ft. in height. The colony is deficient in navigable rivers, and many of the streams are dry or almost so in the warm weather. The Orange is the largest, the other principal streams being Olifants River, flowing w.; the Breede, Groote, Gamtoos, emptying themselves on the s.; the Great Fish and Great Kei, on the s.e.; and the Hartebeest and the Vaal, tributaries of the Orange. The climate is very healthy and generally pleasant. Except along the coast, especially the south-east coast district, where there are extensive forests, timber is scarce, but with irrigation trees can be grown anywhere. The quadrupeds of the colony comprise the African elephant, still found in the forests of the south-east coast region; buffalo, wild-boar, zebra, quagga, leopard, hyena, numerous antelopes, baboon, armadillo, &c. The birds include vultures, eagles, the serpent-eater, pelicans, flamingoes, and, most important of all, the ostrich, now bred in farms

for the sake of its feathers. The cobra and other reptiles are found. The principal minerals are copper ore, coal, iron ore, manganese, and diamonds, amethysts, agates, &c. Coal and copper are worked, and the diamonds have brought a great amount of money into the colony since 1869, and have given rise to the town of Kimberley, the centre of the diamond-fields. Wheat, maize, and other cereals can be grown almost everywhere, if there is sufficient moisture, in some years yielding a surplus for exportation. All kinds of European vegetables, pot-herbs, and fruits thrive excellently, and fruits dried and preserved are exported. The vine is cultivated, and excellent wines are made. Sheep-rearing, especially that of pure merinoes, is the most important industry, and wool the chief export. Ostrich feathers, hides, and skins are also exported. Both native and Angora goats are bred, and the export of mohair is important. Cattle-breeding is also carried on to some extent. There are as yet no manufactures of importance. The colony is intersected by 1600 miles of railway, far-inland Kimberley being now thus connected with Cape Town and Port Elizabeth. British money, weights, and measures are alone in use, except that the general land measure is the Dutch *morgen* = 2.116 acres. The total imports in the year 1890 were £10,106,466; the total exports, £9,970,343, the diamonds being over £4,162,000 in value. The total imports in the year 1891 were £8,582,776; the total exports, £11,131,024, of which diamonds made up £4,174,208, wool £2,264,498, copper £254,184, ostrich feathers £468,221, hides and skins £489,929. The European inhabitants consist in part of English and Scottish settlers and their descendants, but, notwithstanding the recent influx of settlers from Britain, the majority are still probably of Dutch origin. The coloured people are chiefly Hottentots, Kaffirs, Basutos, Griquas, Malays, and a mixed race. The labourers are chiefly Hottentots and Kaffirs. For the higher education there are four colleges, besides a university (at Cape Town) incorporated in 1873. Responsible government has been possessed by the colony since 1872. The executive is vested in the governor (who is appointed by the crown and is also commander-in-chief) and an executive council of office-holders appointed by the crown. The legislative is in the hands of a council of twenty-two members (the Upper House); and a representative house of as-

## CAPE ELIZABETH — CAPE OF GOOD HOPE.

sembly of seventy-six members (Lower House), elected for five years. The estimated revenue in 1892-93 was £4,642,986; the expenditure, £6,436,007; the public debt in 1892 was £23,206,206. The revenue is derived mainly from duties on goods imported. After Cape Town the chief towns are Port Elizabeth, Graham's Town, Kimberley, Stellenbosch, King William's Town, and Graaff Reinet. The Dutch first colonized the Cape in 1652, and till the end of the 18th century the colony was under the Dutch East India Company. It was held by the British from 1795-1801, and it came finally into British possession in 1806. The progress of the colony was long retarded by a series of Kaffir wars, the last of which was in 1851-53.

**Cape Elizabeth**, Cumberland co., Me., has important manufacturing. Pop. 1890, 5459.

**Capefigue** (kâp-fêg), BAPTISTE HONORÉ RAYMOND, French historian and biographer, born 1801. He held various journalistic posts in connection with the Temps, the Messenger, &c., his royalist articles winning him a temporary appointment in the foreign office under the Bourbons. His numerous works include biographies and histories extending over the whole field of French history from the time of Hugh Capet to that of the Empire. He died in 1872.

**Cape Hat'teras**, a dangerous cape on the coast of North Carolina, the projecting point of a long reef of sand.

**Cape Hay'tien**, a town on the N. coast of Hayti. It has an excellent harbour, but has declined in importance since the last century. Pop. about 15,000.

**Cape Horn**, or THE HORN, the southern extremity of an island of the same name, forming the most southerly point of South America. It is a dark, precipitous headland, 500 to 600 feet high, running far into the sea. Navigation round it is dangerous on account of frequent tempests. The cape was first doubled in 1616 by Schouten, a native of Hoorn, in Holland, whence its name.

**Cap'el**, LORD ARTHUR, son of Sir Henry Capel, born about 1600; raised to peerage by Charles I. During the revolutionary

war he fought bravely as one of the royalist generals in the west in the engagements at Bristol, Exeter, and Taunton. Having been at length forced to surrender at Colchester to General Fairfax he was imprisoned, and, after some vicissitudes, executed on March 9, 1649. His Daily Observations or Meditations was published posthumously with a memoir.

**Cap'elin** (*Mallotus villösus*), a small fish



of the salmon family abundant on N. American coasts, and used as bait for cod and also as food.

**Capel'la**, MARTIANUS MINEUS FELIX, a Latin writer of the 4th century, whose work, De Nuptiis Philologiae et Mercurii, was in high repute in the middle ages as an encyclopedia of the liberal culture of the time. His statement of the heliocentric system of astronomy may possibly have given hints to Copernicus.

**Cape of Good Hope**, a celebrated promontory near the southern extremity of Africa, at the termination of a small peninsula extending south from Table Mountain which overlooks Cape Town. This peninsula forms the west side of False Bay, and on its inner coast is Simon's Bay and Simon's Town, where there is a safe anchorage and a Bri-

tish naval station. Bartholomew Diaz, who discovered the Cape in 1487, called it Cape of Storms; but John II. of Portugal changed this to its present designation. It was first doubled by Vasco de Gama in 1497.

**Ca'per**, the unopened flower-bud of a low trailing shrub (*Capparis spinosa*, order Caparidaceæ), which grows from the crevices of rocks and walls, and among rubbish, in the countries bordering the Mediterranean. Picked and pickled in vinegar and salt they are much used as a condiment (caper-sauce being especially the accompaniment of boiled mutton). The plant was introduced into Britain as early as 1596, but has never been grown on a large scale. The flower-buds of the marsh-marigold (*Caltha palustris*) and nasturtium are frequently pickled and eaten as a substitute for capers.

**Capercail'zie**, **CAPERCAIL'IE**, or **COCK OF THE WOOD**, the wood-grouse (*Tetræo urogallus*), the largest of the gallinaceous birds of Europe, weighing from 9 to 12 lbs. In the male the neck and head are ashy black, the wings and shoulders brown with small black dots, the breast variable green, the belly black with white spots, the rump and flanks black with zigzag lines of an ashy colour, and the tail-feathers black, with small white spots near their extremities. The female, about one-third less than the male, is striped and spotted with red or bay, black and white, and has the feathers of the head, breast, and tail of a more or less ruddy hue. It is common in N. Asia, in parts of Russia, and throughout Scandinavia. For some time it was almost or wholly extinct in Great Britain, but has been successfully re-introduced.

**Capernaum** (ka-per'nā-um), a town in ancient Palestine, on the w. side of the Sea of Tiberias. Nothing of it now remains, but the site is identified with Tel Hum.

**Cape St. Vincent**, the s.w. point of Portugal; noted for the naval victory gained off it by Sir John Jervis (afterwards Earl of St. Vincent) on February 14, 1797.

**Ca'pet**, the name of the French race of kings which has given 118 sovereigns to Europe, viz. 36 kings of France, 22 kings of Portugal, 11 of Naples and Sicily, 5 of Spain, 3 of Hungary, 3 emperors of Constantinople, 3 kings of Navarre, 17 dukes of Burgundy, 12 dukes of Brittany, 2 dukes of Lorraine, and 4 dukes of Parma. The first of the Capets known in history was Robert the Strong, a Saxon made Count of Anjou by Charles the Bold, and afterwards duke of

the Ile de France. His descendant, Hugh, son of Hugh the Great, was in 987 elected king of France in place of the Carolingians. On the failure of the direct line at the death of Charles IV. the French throne was kept in the family by the accession of the indirect line of Valois, and in 1589 by that of Bourbon. Capet being thus regarded as the family name of the kings of France, Louis XVI. was arraigned before the National Convention under the name of Louis Capet.

**Cape Town**, capital of the Cape Colony, S. Africa, at the head of Table Bay, and at the base of Table Mountain, 30 miles from the Cape of Good Hope. It is regularly laid out and furnished with most of the institutions and conveniences of a European town, has a fine public library (40,000 vols.) and museum, a Roman Catholic and an Anglican cathedral, new and handsome houses of parliament, government offices, a university, a botanic garden, an observatory, town-house, exchange, railway-station, &c. The port has a breakwater 2000 feet long, two docks 16 acres in area, and a large graving-dock. Besides the railway going inland, a railway connects the town with Simon's Town on False Bay. For topography of this region, see map on opposite page. Pop. 1891, 51,251; including suburbs, 83,718.

**Cape Tulip.** See *Blood-flower*.

**Cape Verd**, the extreme w. point of Africa, between the Senegal and the Gambia, discovered by Fernandez, 1445.

**Cape Verd Islands**, a group of ten or fifteen volcanic islands and rocks in the Atlantic, 320 miles west of Cape Verd (see above), belonging to Portugal. They are, in general, mountainous, and the lower hills are in many places covered with verdure; but water is scarce, and the failure of the annual rains has sometimes caused severe famines. They produce rice, maize, coffee, tobacco, the sugar-cane, physic-nuts, and various fruits. Coffee, hides, archil, physic-nuts, &c., are exported. Most of the inhabitants are negroes or of mixed race. The chief town is Praia, a seaport on São Thiago (Santiago), the largest island. Porto Grande, on São Vicente, is a coaling station for steamers. Pop. about 110,000.

**Cape Wrath**, the north-west extremity of Scotland, county Sutherland. It is a pyramid of gneiss bearing a lighthouse, the light of which is 400 ft. above sea-level.

**Capgrave**, JOHN, English historian, born at Lynn, Norfolk, in 1393. Most of his life

was passed in the Augustinian friary of his native place, where he died in 1464. He was one of the most learned men of his day, and wrote numerous commentaries, sermons, and lives of the saints. His most important work was his Chronicle of England, in English, extending from the creation to the year 1417. Other works were a Liber de Illustribus Henricis and a Life of St. Katherine.

**Ca'pias** (L., take, or you may take), in law, a writ of two sorts: one before judgment, called a *capias ad respondendum*, to take the defendant and make him answer to the plaintiff; the other, which issues after judgment, of divers kinds; as, a *capias ad satisfaciendum*, or writ of execution.

**Cap'illaries**, in anatomy, the fine blood-vessels which form the links of connection between the extremities of the arteries and the beginnings of the veins.

**Capillar'ity**, the general name for certain phenomena exhibited by fluid surfaces when the vessels containing the liquid are very narrow, and also exhibited by that portion of the fluid surface which is in close proximity to the sides of a larger vessel, or to any inserted object. Thus if an open tube of small bore be inserted in water, it will be noted that the liquid rises within it above its former level to a height varying inversely as the diameter of the bore, and that the surface of this column is more or less concave in form (as in fig. 1). The same phenomenon occurs in any fluid which will wet the tube; but in the case of a fluid like mercury, which does not wet the glass, the converse phenomenon appears, the liquid being depressed in the tube below its former level, and the portion within the tube exhibiting a convex surface (see fig. 2). Similarly round the sides of the respective vessels, and round the outsides of

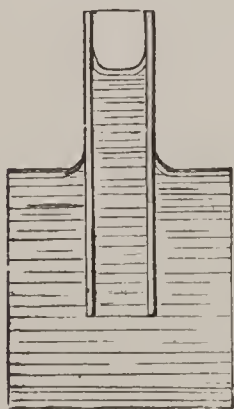

Fig. 1.

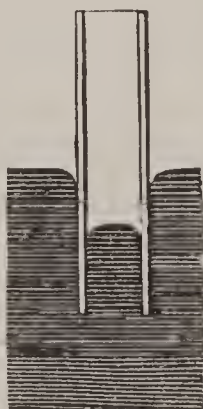

Fig. 2.

the inserted tubes, we find in the first case an ascension, and in the second a depression of the liquid, with a corresponding concavity or convexity at its extreme edge. Two parallel plates immersed in the liquids give kindred results. As these phenomena occur equally in air and *in vacuo* they cannot be attributed to the action of the atmosphere, but depend upon molecular actions taking place between the particles of the liquid itself, and between the liquid and the solid, these actions being confined to a very thin layer forming the superficial boundary of the fluid. Every liquid, in fact, behaves as if a thin film in a state of tension formed its external layer; and although the theory that such tension really exists in the superficial layer must be regarded as a scientific fiction, yet it adequately represents the effects of the real cause, whatever that may be. Scientific calculations with respect to capillary depressions and elevations proceed, therefore, on the working theory that the superficial film at the free surface is to be regarded as pressing the liquid inwards, or pulling it outwards according as the surface is convex or concave—the convex or concave film being known as the *meniscus* (crescent). The part which capillarity plays among natural phenomena is a very varied one. By it the fluids circulate in the porous tissues of animal bodies; the sap rises in plants, and moisture is absorbed from air and soil by the foliage and roots. For the same reason a sponge or lump of sugar, or a piece of blotting-paper soaks in moisture, the oil rises in the wick of a lamp, &c.

**Cap'ital**, in trade, the term applied, as the equivalent of 'stock,' to the money, or property convertible into money, used by a producer or trader for carrying on his business; in political economy, that portion of the produce of former labour which is reserved from consumption for employment in the further production of wealth—the apparatus of production. It is commonly divided under two main heads—circulating capital and fixed capital. Circulating capital comprises those forms of capital which require renewal after every use in production, being consumed (absorbed or transformed) in the single use, *e.g.* raw materials and wages. Fixed capital, on the other hand, comprises every form of capital which is capable of use in a series of similar productive acts, *e.g.* machinery, tools, &c. From the ordinary economic point of view capital is conveniently limited to material



objects directly employed in the reproduction of material wealth, but from the higher social point of view many things less immediately concerned in productive work may be regarded as capital. Thus Adam Smith includes in the fixed capital of a country, 'the acquired and useful abilities of all the inhabitants;' and the wealth sunk in prisons, educational institutions, &c., plays ultimately a scarcely less important part in production than that invested in directly productive machinery.

**Capital**, an architectural term, usually restricted to the upper portion of a column, the part resting immediately on the shaft. In classic architecture each order has its distinctive capital, but in Egyptian, Indian, Saracenic, Norman, and Gothic they are much diversified. See *Column*.

**Capital Punishment**, in criminal law, the punishment by death. Formerly in Great Britain, as in many other countries, it was the ordinary form of punishment for felonies of all kinds; but a more accurate knowledge of the nature and remedies of crime, a more discriminating sense of degrees in criminality, and an increased regard for human life have latterly tended to restrict, if not to abolish, the employment of the penalty of death. The improvement in the penal laws of Europe in this respect may be traced in large part to the publication of Beccaria's treatise on Crimes and Punishments (*Dei Delitti e delle Pene*) in 1764. At that time in England, as Blackstone a year later pointed out with some amount of feeling, there were 160 capital offences in the statute book. The work of practical reform was initiated in 1770 by Sir William Meredith, who moved for a committee of inquiry into the state of the criminal laws; but the modifications secured by it were few, owing to the opposition of the House of Lords, which continued down to 1832 to oppose systematically all attempts at criminal law reform. The publication of Madan's *Thoughts on Executive Justice*, in 1784, urging the stricter administration of the law as it then stood, brought out the opposition of Sir Samuel Romilly, who replied to it in 1785, and introduced at short intervals a series of bills for the abolition of the extreme sentence for minor offences. The influence of Paley and Lord Ellenborough, and the reaction from the revolutionary principles, which prior to the Reign of Terror had inaugurated great penal changes in France, told strongly against

his efforts; and even his Shoplifting Act, to abolish the sentence of death in cases of theft to the value of five shillings, was resolutely rejected, though passed by the Commons in 1810, 1811, 1813, and 1816. Romilly's work was taken up by Sir James Mackintosh in 1820, and under Peel's ministry with greater success. At his death, however, in the year of the passage of the Reform Bill (1832) forty kinds of forgery with many less serious offences were still capital, though from that time the amelioration was rapid. In the 5 years following the Reform Act, the capital offences were reduced to 37, and subsequent changes left in 1861 only four capital charges—setting fire to H.M. dockyards or arsenals, piracy with violence, treason, and murder. At the present time the last of these may be regarded as the only capital crime; and the statement holds good for Scotland also, though robbery, rape, incest, and wilful fire-raising are still capital crimes in Scottish common law. In several other European countries—Sweden, Denmark, North Germany, Bavaria, Austria—there is even a greater unwillingness to enforce capital punishment than is found in Great Britain, though the penalty remains upon the statute books. In Belgium there has been no execution since 1863. In Switzerland capital punishment was abolished in 1874, and though the right of restoring it was allowed to each canton in consequence of an increase of murders, only 7 out of a total of 22 have availed themselves of it. In Roumania it was abolished in 1864; in Holland in 1870; and it has also been discontinued in Portugal. In several of the states of America—Michigan, Wisconsin, Rhode Island, and Maine, imprisonment for life has been substituted for murder in the first degree; in the remainder capital punishment is retained, though the experiment of its abolition was made for a short time in New York and Iowa.

The manner of inflicting the punishment of death has varied greatly. Barbarous nations are generally inclined to severe and vindictive punishments; and even in civilized countries, in cases of a political nature, or of very great atrocity, the punishment has been sometimes inflicted with many horrible accompaniments, such as tearing the criminal to pieces, starving him to death, breaking his limbs upon the wheel, pressing him to death in a slow and lingering manner, burning him at the stake, cruci-

fixion, &c. In modern times amongst civilized nations, public opinion is strongly disposed to discountenance the punishment of death by any but simple means; and even in governments where torture is still countenanced by the laws it is rarely or never resorted to. In Great Britain and in most parts of the United States the method of execution is by hanging. In Germany and France the sword and the guillotine are the usual means; in Spain, strangulation by means of the *garrote*, a sort of iron collar tightened by a screw. Of late some tendency has been shown in various countries to give the preference to electricity as the means of death, and in New York it has been formally adopted. Since 1868 the law of the United Kingdom has required all executions to take place privately within the prison walls, and this system was adopted in 1877 by Germany. Capital punishment cannot be inflicted, by the general humanity of the laws of modern nations, upon persons who are insane or who are pregnant, until the latter are delivered and the former become sane. In military law, sentence of death may be passed for various offences, such as sedition, violence and gross neglect of duty, desertion, assault upon superior officers, disobedience to lawful commands, &c.

**Capitals**, the large letters used in writing and printing, most commonly as the initial letters of certain words. As among the ancient Greeks and Romans, so also in the early part of the middle ages, all books were written without any distinction in the kind of letters, large letters (capitals) being the only ones used; but gradually the practice became common of beginning a book, subsequently, also, the chief divisions and sections of a book, with a large capital letter, usually illuminated and otherwise richly ornamented.

**Capitana'ta.** See *Foggia*.

**Capita'nis**, the hereditary chieftains of certain bands of Christian warriors who, about the beginning of the 16th century, retired to the mountain fastnesses of Northern Greece, where they maintained a kind of independence of the Turkish government, and supported themselves by predatory incursions on the neighbouring provinces. The Turks tried to organize them as a paid police, but with imperfect success; and in the struggle for Greek independence they not only formed an insurgent body of about 12,000 men, but furnished most of the Greek

generals of that period—Odysseus, Karatasso, Marko Bozzaris, &c.

**Capitation-grant**, a grant of so much per head; specifically applied to grants from government or governing bodies to schools according to the number of scholars in attendance, or to the number of those passing a certain test examination, and to volunteer companies on account of such members as reach the stage of 'efficients.'

**Capitation-tax**, a tax or impost upon each head or person. A tax of this kind existed among the Romans, but was first levied in England in 1380, occasioning the rebellion under Wat Tyler. It was again levied in 1513, and by Charles II. in 1667, and abolished 1689. Pennsylvania and Delaware have a poll-tax paying electorate.

**Cap'itol**, now *Campidoglio*, the citadel of ancient Rome, standing on the Capitoline Hill, the smallest of the seven hills of Rome. It was planned by Tarquinius Priscus, but not completed till after the expulsion of the kings. At the time of the civil commotions under Sulla it was burned down, and rebuilt by the senate. It suffered the same fate twice afterwards, and was restored by Vespasian and by Domitian, who instituted there the Capitoline games. The present capitol (*Campidoglio*), standing partly on the site of the old one, is a modern edifice, begun in 1536 after the design of Michael Angelo. It is used as a *hotel de ville*, museum, &c., contains some fine statues and paintings, and commands a superb view of the Campagna.—The name of *capitol* is also given to the edifice in Washington where Congress assembles. Some of the states of North America also call their state-houses *capitols*. The site of the capitol at Washington was selected by Washington in 1791. The interior of the building was burned out by the British in 1814. The corner-stone of a great extension was laid in 1851. The capitol was completed in 1867. It is of sandstone, iron and marble; cost \$14,000,000, fresco-painting and sculpture being used lavishly in interior decorations. The centennial anniversary of the laying of the corner-stone was celebrated, Sept. 18, 1893.

**Capitula'tion**, in military language, the act of surrendering to an enemy upon stipulated terms, in opposition to *surrender at discretion*.

**Cap'nomancy**, divination by the ascent or motion of the smoke either of a sacrifice or of burning vervain, seeds of jasmine, poppy, &c.

**Capo d'Istria**, a port of Austria, on the Gulf of Trieste, 9 miles s. of Trieste, with a cathedral. Pop. 8646.

**Capo d'Istria**, JOHN ANTONY, COUNT, Greek statesman, born at Corfu in 1776. In 1809 he entered the service of Russia and obtained an appointment in the department of foreign affairs. As imperial Russian plenipotentiary he subscribed the Treaty of Paris, Nov. 20, 1815. In 1828 he became president of the Greek Republic, in which office he was very unpopular, and in 1831 he was assassinated by Constantine and George Mauromichalis.

**Caponiere**, or CAPONNIERE (kap-o-neer'), in fortifications, a passage from one part of a work to the other, protected on the right and left by a wall or parapet, and sometimes covered overhead. When there is a parapet on one side only it is called a *demi-caponiere*.

**Cappado'cia**, in antiquity, one of the most important provinces in Asia Minor, the greater part of which is included in the modern province of Karaman. Its boundaries varied greatly at different times. It was conquered by Cyrus, and was ruled by independent kings from the time of Alexander the Great until 17 A.D., when it became a Roman province. It was traversed by the river Halys, and among its chief towns were Comana, Ariarathia, and Tyana.

**Cappagh Brown** (kap'ah), a bituminous earth, coloured by oxide of manganese and iron, which yields pigments of various rich brown colours: called also *manganese brown*. It derives its name from Cappagh, near Cork, in Ireland.

**Capparida'ceæ**, a nat. order of dicotyledonous, polypetalous, herbaceous plants, shrubs and trees, having four petals and sepals, a great number of stamens, and an ovary elevated upon a long stalk. All of them appear to be more or less acrid. Some are very poisonous, others act as vesicatories, and a few are merely stimulant, as the *Capparis spinōsa*, or caper-bush, the flower-buds of which constitute the capers of the shops.

**Capraja** (kā-prä'yà), a small volcanic island belonging to Italy, about 15 miles in circumference, situated between the north point of Corsica and the coast of Tuscany. Its principal product is wine.

**Cap'reæ**. See *Capri*.

**Capre'ra**, a small rocky and infertile Italian island, on the N.E. of Sardinia, and separated from it by a narrow strait. Area

about 15 sq. m. It was for many years the place of retirement of the Italian liberator Garibaldi, who died here in 1882.

**Capri**, ancient *Capræa*, an island belonging to Italy, in the Gulf of Naples, 5 miles long and 2 broad, rising to the height of about 1900 feet, everywhere well cultivated. The inhabitants, amounting to 6000, are occupied in the production of oil and wine, in fishing, and in catching quails at the seasons of their migrations. It contains the towns of Capri in the east, and Anacapri in the west, situated on the summit of a rock, and accessible by a stair of 522 steps. The emperor Tiberius spent here the last seven years of his life in degrading voluptuousness and infamous cruelty. The ruins of his palaces are still extant, and other ruins are scattered over the island. The island has several stalactitic caverns or grottoes in its steep rocky coast, which are famed for the wondrous colours reflected on the rocks, the Blue Grotto being the most famous.

**Capriccio** (ka-prich'i-o), a musical composition, the form of which is left very much to the composer's fancy.

**Cap'ricornus**, CAPRICORN, a constellation of the southern hemisphere, and one of the twelve signs of the zodiac, the one to which belongs the winter solstice, represented by the figure of a goat or a figure having the fore-part like a goat and the hind-part like a fish. Its symbol is ♄. *Tropic of Capricorn*. See *Tropics*.

**Cap'ridæ** (L. *caper*, a goat), the goat tribe, a family of ruminating animals, in which the horns are directed upwards and backwards, and have a bony core.

**Caprifica'tion**, a horticultural operation performed by the ancients upon figs. It consists in suspending above the cultivated figs branches of the wild fig covered with a species of gall insect, which carries the pollen of the male flowers to fertilize the female flowers of the cultivated fig. The term is also applied to the fecundation of the female date palms by shedding over them the pollen from the male plant.

**Caprifolia'ceæ**, a nat. order of monopetalous dicotyledons. It includes a number of erect or twining shrubs and herbaceous plants, comprising the honeysuckle, elder, viburnum, and snowberry. The characteristics of the order are opposite leaves without stipules, free anthers, epipetalous stamens, and fruit not splitting open when ripe.

**Caprimul'gidæ**, the goat-suckers, a family of insessorial, fissirostral birds, nearly allied to the Hirundinidæ or swallow tribe.

**Cap'sicin**, an alkaloid, the active principle of the capsules of *Capsicum annuum*, or Guinea pepper. It has a resinous aspect and a burning taste.

**Cap'sicum**, a genus of annual, sub-shrubby plants, order Solanaceæ, with a wheel-shaped corolla, projecting and converging stamens, and a many-seeded berry. They are chiefly natives of the East and West Indies, China, Brazil, and Egypt, but have spread to various other tropical or sub-tropical countries, being cultivated for their fruit, which in some reaches the size of an orange, is fleshy and variously coloured, and contains a pungent principle (see *Cap'sicin*) which is present also and more largely in the seed. The fruit or pod is used for pickles, sauces, &c., and also medicinally. Several of them, as *C. annuum*, *C. frutescens*, and *C. baccatum*, yield Cayenne pepper, and the first (called often Guinea pepper, though originally a native of South America) also yields chillies. *C. baccatum* is called bird-pepper. See *Cayenne Pepper*.



*Capsicum*  
(*Capsicum annuum*).

**Cap'stan**, a strong upright column of timber, movable round a strong iron spindle, and having its upper extremity pierced to receive bars or levers, for winding a rope round it to raise weights, such as the anchors of a vessel, or to perform other work that requires great power.

**Cap'sule**, in botany, a dry fruit containing many cells and seeds, and usually opening by valves. Also, a small tube-like vessel of gelatine used in the administration of medicines, which are contained therein.

**Captain**, one who is at the head or has authority over others, especially: (1) The military officer who commands a company, whether of infantry, cavalry, or artillery. (2) An officer in the navy commanding a ship of war. The naval captain is next in rank above the commander, and in the U. States ranks with a colonel. Captains are generally appointed from the rank of commander in the order of seniority by the President, subject to the Senate's approval.

**Captain of the fleet**, in the British navy, a flag-officer temporarily appointed by the admiralty, who acts as adjutant-general of the force, sees to the carrying out of the orders of the commander-in-chief, and to proper discipline being maintained in the fleet. (3) The master of a merchant vessel.

**Caption**, in law, a certificate stating the time and place of executing a commission in chancery, or of taking a deposition, or of the finding of an indictment, and the court or authority before which such act was performed, and such other particulars as are necessary to render it legal and valid.

**Cap'ua**, a fortified city of Italy, province Caserta, in a plain 18 miles N. Naples, on the Volturno, which is crossed by a handsome bridge. It is the residence of an archbishop, and has a cathedral. Pop. 13,886. The ancient city was situated 3½ miles S.E. from the modern town. The site is now occupied by a small town, called Santa-Maria-di-Capua Vetere. The ancient Capua was of such extent as to be compared to Rome and Carthage. It was a favourite place of resort of the Romans on account of its agreeable situation and its healthy climate, and many existing ruins (including an amphitheatre) attest its ancient splendour.

**Capuchin Monkey** (kap-ŭ-shēn'), a name given to various species of South American monkeys of the genus *Cebus*. The hair of their heads is so arranged that it has the appearance of a capuchin's cowl, hence the name. The name is most frequently given to the Sai (*Cebus Capuchinus*), the Horned Sapajou (*C. fatuellus*), as well as to *Pithecia chiroptes*, a monkey belonging to an allied species.

**Capuchins** (kap-ŭ-shēnz'), monks of the order of St. Francis, so called from the *capuchon* or *capuce*, a stuff cap or cowl, the distinguishing badge of the order. They are clothed in brown or gray, go barefooted, and never shave their beard. See *Franciscans*.

**Caput mor'tuum** (L.), literally, a dead head; a fanciful term much used by the old chemists to denote the residuum of chemicals when all their volatile matters had escaped; hence, anything from which all that rendered it valuable has been taken away.

**Capyba'ra** (*Hydrochærus capybāra*), a species of rodent, sometimes known by the name of the water-hog, and of the family Cavidæ (guinea-pig). It attains the length of about 3 feet, and has a very large and thick head, a thick body covered with short, coarse,

brown hair, and short legs, with long feet, which, being in a manner webbed, fit it for an aquatic life. It has no tail. It is common in several parts of South America, and



Capybara (*Hydrochoerus capybara*).

particularly in Brazil. It feeds on vegetables and fish, which it catches somewhat in the manner of the otter.

**Carab'idæ**, a family of beetles, usually large, adorned with brilliant metallic colours, and either wingless or having wings not adapted for flying. The bombardier beetle belongs to this family.

**Car'abine**, or **CARBINE**, the name given to a short rifle, such as is carried by the British cavalry, artillery, the Irish constabulary, and other corps. The name of carabinieri is given to the 6th Dragoon Guards, probably because they were the first regiment of cavalry to be armed with this weapon.

**Carabo'bo**, a state of Venezuela, washed on the N. by the Caribbean Sea. Area about 2,984 sq. m.; pop. 167,499. The capital is Valencia, the chief port Puerto Cabello.

**Car'abus**, a genus of beetles, type of the family Carabidæ (which see).

**Car'acal**, a species of lynx (*Felis caracal*), a native of Northern Africa and South-western Asia. It is about the size of a fox, and mostly of a deep-brown colour, having tufts of long black hair which terminate the ears. It possesses great strength and fierceness.

**Caracal'la**, **MARCUS AURELIUS ANTONINUS**, eldest son of the Emperor Severus, was born at Lyons A.D. 188, died 217. On the death of his father he succeeded to the throne with his brother Antoninus Geta, whom he speedily murdered. To effect his own security upwards of 20,000 other victims were butchered. He was himself assassinated by

Macrinus, the pretorian prefect, who succeeded him.

**Caraca'ra** (from its hoarse cry), the popular name for *Polyöbrus Braziliensis* (the Brazilian caracara) and several other raptorial birds of the sub-family Polyborinæ, family Falconidæ. They are of considerable size, natives of South America, and are characterized by having the bill hooked at the tip only, the wings long, and the orbits, cheeks, and part of the throat more or less denuded of feathers.

**Carac'as**, a city of South America, capital of Venezuela, situated in a fine valley about 3000 feet above the Caribbean Sea, connected by railway with the port La Guayra, about 10 miles distant. It is regularly laid out, and has some good buildings, including a cathedral, university, federal palace, and other government buildings, &c. It has various parks and gardens, gas and water supply, telephones, tramways, &c. In 1812 it was in great part destroyed by an earthquake, and nearly 12,000 persons buried in the ruins. Pop. 1891, 72,420.

**Caracci** (kà-râch'ē). See *Carracci*.

**Caraccioli** (kà-râch'o-lē), **FRANCESCO**, Italian admiral, born at Naples about 1748, died 1799. In 1798 he entered the service of the Parthenopean Republic, and repelled, with a few vessels, an attempt of the Sicilian-English fleet to effect a landing. When Ruffo took Naples in 1799 Caraccioli was arrested, and, contrary to the terms of capitulation, was condemned to death, and hanged at the yard-arm of a Neapolitan frigate, Lord Nelson consenting to his execution.

**Car'adoc**, or **CARAC'TACUS**, a king of the ancient British people called Silures, inhabiting South Wales. He defended his country with great perseverance against the Romans, but was at last defeated, and led in triumph to Rome, A.D. 51, after the war. His noble bearing and pathetic speech before the Emperor Claudius procured his pardon, but he and his relatives appear to have remained in Italy.

**Caradoc Sandstone**, in geology, an upper division of the lower Silurian rocks, consisting of red, purple, green, and white micaceous and sometimes quartzose grits and limestones containing corals, mollusca, and trilobites. Named after the hilly range of *Ca. r-Caradoc* in Shropshire.

**Carafe** (ka-raf'), the French name for an ordinary glass bottle or decanter for holding drinking water.

**Car'ageen.** See *Carrageen*.

**Ca'raites.** See *Karaites*.

**Car'aman.** See *Karaman*.

**Carama'nia.** See *Karamania*.

**Caram'bola**, the fruit of an East Indian tree, the *Averrhōa Carambōla*, order Oxalidaceæ. It is of the size and shape of a duck's egg, of an agreeable acidulous flavour, used in making sherbets, tarts, and preserves.

**Car'amel**, the brown mass which cane-sugar becomes at 220° C., used in cookery as a colouring and flavouring ingredient, in giving a brown colour to spirits, &c.—The name of a certain preparation of candy.

**Caran'a Resin**, a kind of balsamic resin obtained from *Bursēra acumināta* and imported from tropical America.

**Carapa**, a genus of tropical plants, nat. order Meliaceæ. A South American species, *C. guianensis*, is a fine large tree, whose bark is in repute as a febrifuge. Oil made from its seeds (called carap-oil or crab-oil) is used for lamps, and masts of ships are made from its trunk. The wood is called crab-wood. The oil of the African species, *C. guineensis*, called Coondi, Kundah, or Tallicoona oil, is used by the negroes for making soap and anointing their bodies. The oil of the South American carapa is used for the same purpose also.

**Car'apace**, the upper part of the hard shell or case of chelonian reptiles, as the tortoise or turtle, the lower part being called *plastron*. The same name is also given to the covering of the anterior superior surface of the Crustacea.

**Car'at**, a weight of 3·17 troy grains, used by jewellers in weighing precious stones and pearls. The term is also used to express the proportionate fineness of gold. The whole mass of gold is divided into twenty-four equal parts, and it is called gold of so many carats as it contains twenty-fourth parts of pure metal. Thus if a mass contain twenty-two parts of pure gold out of every twenty-four it is gold of twenty-two *carats*.

**Carau'sius**, a Roman general, a native of Batavia. He was sent by the Emperor Maximian to defend the Atlantic coasts against the Franks and Saxons; but foreseeing impending disgrace, he landed in Britain and got himself proclaimed emperor by his legions (287 A.D.). In this province he was able to maintain himself six years, when he was assassinated at York by one of his officers named Allectus (293 A.D.).

**Carava'ca**, a town, Spain, province of Murcia, and 43 miles w. by N. of the town of Murcia. It has manufactures of woollen and hempen goods, paper, soap, and earthenware. Pop. 15,017.

**Caravaggio** (kà-rà-vàj'ō), a town of N. Italy, prov. of Bergamo, 24 miles E. of Milan, on the Gera d'Adda. It is celebrated as the birthplace of the two great painters Polidoro Caldara and Michel Angelo Merighi, both called *Caravaggio*. Pop. 6089.

**Caravaggio**, MICHEL ANGELO AMERIGHI, or MERIGHI DA, a celebrated painter, born at Caravaggio 1569, died 1609. He attained distinction as a colourist of the Neapolitan school, being considered the head of the so-called Naturalists' school. He was coarse and violent in his character and habits, and was in continual trouble through his quarrelsome disposition. Among his chief pictures are the Card Player (at Dresden), the Burial of Christ, St. Sebastian, Supper at Emmaus, and a Holy Family.

**Caravaggio.** See *Caldara*.

**Car'avan**, a Persian word used to denote large companies which travel together in Asia and Africa for the sake of security from robbers, having in view, principally, trade or pilgrimages. In Mohammedan countries caravans of pilgrims are annually formed to make the journey to Mecca. The most important are those which annually set out from Damascus and Cairo. Camels are used as a means of conveyance on account of their remarkable powers of endurance.

**Caravan'sary**, CARAVANSERAI, in the East, a place appointed for receiving and lodging caravans; a kind of inn where the caravans rest at night, being a large square building with a spacious court in the middle. Though caravansaries in the East serve in place of inns, there is this radical difference between them, that, generally speaking, the traveller finds nothing in a caravansary for the use either of himself or his cattle. He must carry all his provisions and necessaries along with him. Those built in towns serve not only as inns, but contain shops, warehouses, and even exchanges.

**Car'avel**, the name of different kinds of vessels, particularly a small ship used by the Spaniards and Portuguese in the 15th and 16th centuries for long voyages. It was narrow at the poop, wide at the bow, and carried a double tower at its stern and a single

one at its bows. It had four masts and a bowsprit, and the principal sails were lateen sails. It was in command of three such



Caravel of the fifteenth century.

caravels that Columbus crossed the Atlantic and discovered America.

**Caravel'as**, a seaport of Brazil, prov. Bahia, the principal port of the surrounding country, and the head-quarters of the Abrolhos Islands whale-fishery. Pop. about 4000.

**Car'away** (*Carum Carui*), an umbelliferous biennial plant, with a tapering fleshy root, a striated furrowed stem, and white or pinkish flowers. It produces a well-known seed used in confectionery, and from which both a carminative oil is extracted and the liqueur called *kümmel* prepared.

**Carbazot'ic Acid** (from *carbon* and *azote*;  $C_6H_3N_3O_7$ ), a crystallizable acid and bitter substance obtained by the action of nitric acid on indigo and some other animal and vegetable substances. It is of great importance in dyeing. When silk which has been treated with a mordant of alum or cream of tartar, is immersed in a solution of this acid, it is dyed of a beautiful permanent yellow colour. Often called *Picric Acid*.

**Car'berry Hill**, a rising ground in Mid-Lothian, about 7 miles to the S.E. of Edinburgh, where Mary Queen of Scots surrendered herself to the confederate nobles of the kingdom, June 15, 1567.

**Car'bide**, a compound of carbon with a metal, the usual effect of which is to render it hard and brittle. Formerly called *Carburet*.

**Car'bine**. See *Carabine*.

**Carbohy'drate**, an organic compound

containing carbon and the elements of water, as starch and cellulose.

**Carbol'ic Acid** ( $C_6H_6O$ ), an acid obtained from coal-tar. It is, when pure, a colourless crystalline substance, but it is usually found as an oily liquid, colourless, with a burning taste and the odour of creosote. Carbolic acid is now much employed as a therapeutic and disinfectant. It may be taken internally in cases in which creosote is indicated; but its principal use in medicine is as an external application to unhealthy sores, compound fractures, and to abscesses after they have been opened, over which it coagulates, forming a crust impermeable to air and to the organic germs floating in the atmosphere, which produce decomposition in the wound. The action of the acid is not only to exclude these germs but also to destroy such as may have been admitted, for which reason it is introduced into the interior of the wound. Called also *Phenic Acid* and *Phenol*.

**Carbon**, one of the elements, existing uncombined in three forms, charcoal, graphite or plumbago, and the diamond; chemical symbol C, atomic weight 12. The diamond is the purest form of carbon; in the different varieties of charcoal, in coal, anthracite, &c., it is more or less mixed with other substances. Pure charcoal is a black, brittle, light, and inodorous substance. It is usually the remains of some vegetable body from which all the volatile matter has been expelled by heat; but it may be obtained from most organic matters, animal as well as vegetable, by ignition in close vessels. Carbon being one of those elements which exist in various distinct forms is an example of what is called *allotropy*. The compounds of this element are more numerous than those of all the other elements taken together. With hydrogen especially it forms a very large number of compounds, called hydrocarbons, which are possessed of the most diverse properties, chemical and physical. With oxygen, again, carbon forms only two compounds, but union between the two elements is easily effected. It is one of the regular and most characteristic constituents of both animals and plants. See *Diamond*, *Charcoal*, *Graphite*, *Bone Black*, *Carbonic Acid*, *Coke*, &c.

**Carbona'ri** (lit. 'charcoal-burners'), the name of an Italian political secret society, which appears to have been formed by the Neapolitan republicans during the reign of Joachim (Murat), and had for its object

## CARBONATES — CARBONIFEROUS SYSTEM.

the expulsion of the strangers and the establishment of a democratic government. The ritual of the Carbonari was taken from the trade of the charcoal-burner. A lodge was *baracca* (a hut); a meeting was *vendita* (a sale); an important meeting *alta vendita*. There were four grades in the society; and the ceremonies of initiation were characterized by many mystic rites. The language of religion was much used to express their purposes. Christ was the lamb torn by the wolf and whom they were sworn to avenge. Clearing the wood of wolves (opposition to tyranny) became the symbolic expression of their aim. By this they are said to have meant at first only deliverance from foreign dominion; but in later times democratical and antimonarchical principles sprang up, which were discussed chiefly among the higher degrees. The order, soon after its foundation, contained from 24,000 to 30,000 members, and increased so rapidly that it spread through all Italy. In 1820, in the month of March alone, about 650,000 new members are said to have been admitted. After the suppression of the Neapolitan and Piedmontese revolution in 1821, the Carbonari, throughout Italy, were declared guilty of high treason, and punished as such by the laws. Meantime societies of a similar kind had been formed in France, with which the Italian Carbonari amalgamated; and Paris became the head-quarters of Carbonarism. The organization took on more of a French character, and gradually alienated the sympathies of the Italian members, a number of whom dissolved connection with it, in order to form the party of 'Young Italy.'

**Carbonates**, compounds formed by the union of carbonic acid with a base, as the carbonate of lime, the carbonate of copper, &c. Carbonates are an important class of salts, many of them being extensively used in the arts and in medicine.

**Carbondale**, an American city, state of Pennsylvania, about 110 miles N.N.W. of Philadelphia. It is the centre of a rich coal-field. Pop. 1890, 10,833.

**Carbonic Acid** ( $\text{CO}_2$ ), more properly called *Carbonic Anhydride*, or *Carbon Dioxide*, a gaseous compound of 12 parts by weight of carbon and 32 of oxygen, colourless, without smell, twenty-two times as heavy as hydrogen, turning blue litmus slightly red, and existing in the atmosphere to the extent of 1 volume in 2500. It is incapable of supporting combustion or animal

life, acting as a narcotic poison when present in the air to the extent of only 4 or 5 per cent. It is disengaged from fermenting liquors and from decomposing vegetable and animal substances, and is largely evolved from fissures in the earth, constituting the choke-damp of mines. From its weight it has a tendency to subside into low places, vaults and wells, rendering some low-lying places, as the upas valley of Java, and many caves, uninhabitable. It has a pleasant, acidulous, pungent taste, and aerated beverages of all kinds—beer, champagne, and carbonated mineral water—owe their refreshing qualities to its presence, for though poisonous when taken into the lungs, it is agreeable when taken into the stomach. This acid is formed and given out during the respiration of animals, and in all ordinary combustions, from the oxidation of carbon in the fuel. It exists in large quantity in all limestones and marbles. It is evolved from the coloured parts of the flowers of plants both by night and day, and from the green parts of plants during the night. During the day plants absorb it from the atmosphere through their leaves, and it forms an important part of their nourishment.

**Carbonic Oxide** ( $\text{CO}$ ), a substance obtained by transmitting carbonic acid over red-hot fragments of charcoal, contained in a tube of iron or porcelain, and also by several other processes. It is a colourless inodorous gas, sp. gr. 0.9727, has neither acid nor alkaline properties, is very poisonous, and burns with a pale lavender flame.

**Carboniferous System**, in geology, the great group of strata which lie between the Old Red Sandstone below and the Permian or Dyas formation above, named from the quantities of coal, shale, and other carbonaceous matter contained in them. They include the coal measures, millstone grit, and mountain limestone, the first being uppermost and containing the chief coal-fields that are worked. Iron-ore, limestone, clay, and building-stone are also yielded abundantly by the carboniferous strata which are found in many parts of the world often covering large areas. (See *Coal*.) The thickness of the coal measures in South Wales has been estimated at 10,000 to 13,000 feet. As coal consists essentially of metamorphosed vegetable matter, fossil plants are very numerous in the carboniferous rocks, more than 1500 species of them having been named, a large proportion of which are ferns, tree



lycopods, and large horse-tail-like plants. The animals include insects, scorpions, amphibians, numerous corals, crinoids, molluscs, cephalopods, sharks, and other fishes.

**Carbon Points**, in electric lighting, two pieces of very hard, compact carbon, between which the electric current is broken, so that the resistance which they offer to the passage of the current produces a light of extraordinary brilliancy.

**Car'boy**, a large and somewhat globular bottle of green glass protected by an outside covering of wickerwork or other material, for carrying vitriol or other corrosive liquid.

**Carbun'cle**, a beautiful gem of a deep-red colour with a mixture of scarlet, found in the East Indies. When held up to the sun it loses its deep tinge, and becomes exactly of the colour of a burning coal. The carbuncle of the ancients is supposed to have been a garnet.

**Carbun'cle**, in surgery, an inflammation of the true skin and tissue beneath it akin to that occurring in boils. It is more extensive than the latter, and instead of one has several cores. It is associated with a bad state of general health, from which condition its danger arises, for it may threaten life by exhaustion or blood poisoning. With regard to the local treatment, the principal thing to be done is to make a free incision into the tumour; as much of the contents as possible should then be pressed out, and a poultice applied. The patient's strength should be supported by nourishing and easily-digested food, and tonics and cordials should be administered.

**Car'buret**, the old name for *Carbide*.

**Car'buretted Hydrogen**, the name given to two compounds of carbon and hydrogen, one known as *light carburetted hydrogen*, and the other as *olefiant gas*. The former is the compound  $\text{CH}_4$  which occurs in coal-mines (fire-damp) and about the neighbourhood of stagnant pools. Mixed with atmospheric air from 7 to 14 times that of the gas it explodes. The latter is obtained from distilling coal or fat substances in close vessels. Its symbol is  $\text{C}_2\text{H}_2$ , and it explodes when mixed with ten or twelve volumes of atmospheric air.

**Carcagente** (kár-kà-hen'tā), a town, Spain, province of Valencia, on the Jucar, well built, with delightful promenades and gardens. Trade in grain, fruits, and silk. Pop. 12,102.

**Car'cajou**, a species of badger found in N. America, *Meles labradorica*.

**Car'canet**, a necklace or collar of jewels.

**Car'cass**, in military language, an iron case, with several apertures, filled with combustible materials, which is discharged from a mortar, howitzer, or gun, and intended to set fire to buildings, ships, and wooden defences.

**Carcassonne**, capital of the dep. Aude, France, on the Aude and a branch of the Canal du Midi, 53 miles s. of Toulouse. It consists of an old and a new town, which communicate by a bridge spanning the river. The old town is surrounded by a double wall, part of it so ancient as to be attributed to the Visigoths. The new town is regularly built, and has many handsome modern houses. The staple manufacture is woollen cloth. Pop. 27,512.

**Carcino'ma**. See *Cancer* (disease).

**Card**, an instrument for combing, opening, and breaking wool, flax, &c., freeing it from the coarser parts and from extraneous matter. It is made by inserting bent teeth of wire in a thick piece of leather, and nailing this to a piece of oblong board to which a handle is attached. But wool and cotton are now generally carded in mills by teeth fixed on a wheel moved by machinery. The word is derived through the French *carde*, a teasel, from *L. carduus*, a thistle, teasels having been used for cards.

**Card**, an oblong piece of thick paper or pasteboard prepared for various purposes. (1) A piece of card-board with one's name written or printed on it, used in visiting, and generally for indicating the name of the person presenting it. (2) A piece of card-board on which are printed certain coloured devices or figures, forming one of a *pack*, and used in playing games. A modern pack of playing-cards numbers fifty-two, and consists of four *suits*, two red (hearts and diamonds), and two black (spades and clubs), each suit comprising thirteen cards — three picture-cards (*court-cards*), the king, queen, and knave; and ten other cards numbered from one, the ace, to ten, according to the pips or marks belonging to the respective suits printed on them. They are generally said to be of Eastern origin, but this is doubtful. They were known in Europe in the 14th century. The manufacture of playing cards, from the enormous numbers of them used, is now one of some importance, and they are produced in a rather artistic and effective style, the backs often being very ornamental. An immense variety of games are played with cards, some involv-

ing chance only, some combining chance and skill, the best of them furnishing very agreeable and intellectual amusement; whist, perhaps, the best, is a very fine game.

**Cardamine** (kar-da-mī'nē), a genus of plants, nat. order Cruciferæ. See *Cuckoo-flower*.

**Car'damoms**, the aromatic capsules of different species of plants of the nat. order Zingiberaceæ (gingers), employed in medicine as well as an ingredient in sauces and curries. The cardamoms known in the shops are the large, supposed to be produced by *Amōmum angustifolium*, a Madagascar plant; the middle-sized and the small, both supposed to be the produce of *A. Cardamōmum*, a native of Sumatra and other eastern islands. Those recognized in the U. S. pharmacopœia, called *true* or *officinal cardamoms* and known in commerce as *Malabar cardamoms*, are the produce of *Elettaria (Alpinia) Cardamōmum*, a native of the mountains of Malabar and Canara. Ceylon cardamoms are the fruit of *A. grana-paradisi*.

**Cardan**, or CARDA'NO, GERONIMO (*Hieronymus Cardānus*), Italian philosopher, physician, and mathematician, was born in 1501 at Pavia; died about 1576. He held successively the chairs of mathematics or medicine at Pavia, Milan, and Bologna, and ultimately went to Rome. Here he was received into the medical college, and was allowed a pension by the pope. He acquired extraordinary reputation as a physician, and was invited to Scotland to attend Archbishop Hamilton of St. Andrews, who had been sick for ten years, and who was restored to health by his prescriptions. He made some important discoveries in algebra, studied astrology, pretended to a gift of prophecy, and wrote a large number of books. His chief works are *De Vita Propria*, an account of himself; *Ars Magna*, a treatise on Algebra; *De Rerum Varietate*; *De Rerum Subtilitate*; &c.

**Card'board**, a kind of stiff paper or paste-board for cards, &c., usually made by sticking together several sheets of paper.

**Carde'nas**, a seaport on the north coast of Cuba, 103 miles E. of Havana, with which it is connected by rail. One of the principal commercial centres of the island; chief exports, sugar, molasses, and coffee. Pop. 12,910.

**Cardi**, LODOVICO, surnamed *Civoli* or *Cigoli*, Italian painter and architect, born in 1559, died 1631. He studied painting, and

afterwards formed his style on the works of Andrea del Sarto, Correggio, and Baroccio. His architectural works possess considerable merit. Among his pictures are: The Conversion of St. Paul at Rome, The Martyrdom of Stephen, The Trinity, Mary Magdalene, and Ecce Homo at Florence. He painted many altar-pieces, excelled to some degree as an engraver, and wrote a treatise on Perspective.

**Cardiac Medicines**, medicines which act upon the heart.

**Car'diadæ**, a family of lamellibranchiate molluscs, including the cockles and their allies.

**Car'diff** ('the city on the *Taff*'), a municipal and parliamentary borough and seaport, the county town of Glamorganshire, Wales, situated at the mouth of the Taff on the estuary of the Severn. It is a rapidly increasing town, and the principal outlet for the mineral produce and manufactures of South Wales. Iron ship-building is carried on, and there are iron and other works on a large scale. Among the chief buildings are the county buildings, town-hall, infirmary, university college (for S. Wales and Monmouthshire), law courts, free library and museum, &c. The docks are extensive and well constructed (total area about 200 acres), and various improvements to the port have been lately carried out. As regards tonnage entered and cleared, Cardiff is now the third port in the United Kingdom; in respect of coal exported it is the first, over 7,300,000 tons being sent abroad in 1887. There is here a castle which dates from 1080. It is the property of the Marquis of Bute, who has modernized it, and converted part of it into a residence. The development of Cardiff has been greatly furthered by those in charge of the Bute property, which embraces most of the town. The town conjointly with Cowbridge and Llantrissant returns one member to the House of Commons. Pop. in 1861, 32,954; in 1881, 82,761; in 1891, 128,849.

**Car'digan**, the county town of Cardiganshire, South Wales, on the river Teifi, about 3 miles from its mouth in Cardigan Bay. Vessels of light tonnage come up to the wharves. The ruins of Cardigan Castle, famous in Welsh history, are in the vicinity. The salmon-fishery is extensively carried on. Previous to 1885 it was one of a group of parliamentary boroughs. Pop. 3447.—The COUNTY of Cardigan has an area of

443,387 acres, of which two-thirds is under crops or pasture. The surface of the northern and eastern parts is mountainous, but interspersed with fertile valleys; while the southern and western districts are more level and produce abundance of corn. The county has an extensive coast-line, and many of the male population are sailors and fishermen. It is rich in metalliferous lodes, the lead-mines still yielding largely. The principal town is Aberystwith. The county returns one member to parliament. Pop. 1891, 62,596.

**Cardigan Bay**, a large open expanse of sea on the west coast of Wales, having Cardiganshire on the east and Carnarvon on the north.

**Car'dinal**, an ecclesiastical prince in the Roman Catholic Church, who has a voice in the conclave at the election of a pope, the popes being taken from the cardinals. The cardinals are appointed by the pope, and are divided into three classes or orders, compris-

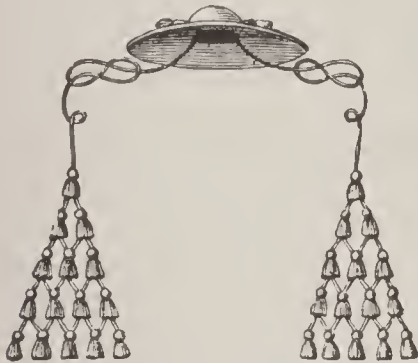

Cardinal's Hat.

ing six bishops, fifty priests, and fourteen deacons, making seventy at most. These constitute the Sacred College and compose the pope's council. Originally they were subordinate in rank to bishops; but they now have the precedence. The chief symbol of the dignity of cardinal is a low-crowned, broad-brimmed red hat, with two cords depending from it, one from either side, each having fifteen tassels at its extremity. Other insignia are a red biretta, a purple cassock, a sapphire ring, &c.

**Cardinal Bird**, *Cardinalis virginianus*, a North American bird of the finch family, with a fine red plumage, and a crest on the head. Its song resembles that of the nightingale, hence one of its common names, *Virginian Nightingale*. In size it is about equal to the starling. Called also *Scarlet Grosbeak* or *Cardinal Grosbeak* and *Red-bird*.

**Cardinal-flower**, the name commonly

given to *Lobelia cardinalis*, because of its large, very showy, and intensely red flowers; it is a native of North America, but is much cultivated in gardens in Britain.

**Cardinal Points**, the N., S., E., and W. points of the horizon; the four intersections of the horizon with the meridian and the prime vertical circle.

**Cardinal Virtues**, or **PRINCIPAL VIRTUES**, in morals, a name applied to justice, prudence, temperance, and fortitude.

**Carding**, the process wool, cotton, flax, &c., undergo previous to spinning, to lay the fibres all in one direction, and remove all foreign substances. See *Card*.

**Cardi'tis**, inflammation of the heart substance. Inflammation of the lining membrane is *endocarditis*, of the external membrane *pericarditis*. See *Heart*.

**Car'dium**. See *Cockle* (the mollusc).

**Cardo'na**, a Spanish town, prov. of Barcelona. In its vicinity is a hill of rock-salt 500 feet high, which has a dazzling appearance in the sunlight. Pop. 4360.

**Cardoon'**, the *Cynara Cardunculus*, a perennial plant belonging to the same genus as the artichoke, and somewhat resembling it. It is a native of Canada. The thick fleshy stalks and ribs of its leaves are blanched and eaten as an esculent vegetable. In this country they are not much esteemed, but form an important object in France.

**Cards, Playing**. See *Card*.

**Car'duus**. See *Thistle*.

**Careening**, a nautical term for heaving or bringing a ship to lie on one side for the purpose of caulking, repairing, cleansing, paying with pitch, or the like.

**Ca'ret** (L., 'there is something wanting'), in writing, a mark made thus,  $\wedge$ , which shows that something, omitted in the line, is interlined above or inserted in the margin, and should be read in that place.

**Carew** (ka-rö'), THOMAS, an English poet, born of a Gloucestershire family in 1589, died 1639. Educated at Oxford, he cultivated polite literature in the midst of a life of affluence and gaiety, and was the subject of much eulogy by Ben Jonson, Davenant, and other writers of the period. His works are masques, lyrics, and sonnets, and were first printed in 1640. Carew is coupled with Waller as one of the improvers of English versification.

**Ca'rex**, a large genus of plants, nat. order Cyperaceæ; the sedges. They are perennial grass-like herbs, with unisexual flowers aggregated in spikelets. There are more

than a thousand species distributed all over the world, over 140 of which are natives of North America.

**Ca'rey, HENRY**, a composer, dramatist, and poet, born at London in 1696, was a natural son of George Saville, Marquis of Halifax. He composed the words and music of many popular songs, including Sally in Our Alley, God Save the King, &c. He also wrote farces and other works. He is said to have committed suicide, 1743. His son **GEORGE SAVILLE CAREY** (born about 1743, died 1807) was also a voluminous writer of songs.

**Carey, HENRY CHARLES**, American economist, born in Philadelphia 1793, died 1879. He was the eldest son of Matthew Carey, and in 1814 became a partner in his father's bookselling and publishing firm, where he continued until 1836. In that year he published an essay on the Rate of Wages, which he afterwards expanded into Principles of Political Economy. His other important works are The Credit System, The Past, the Present, and the Future, The Principles of Social Science, &c. Originally a free-trader he became an advocate for protection; held that the growth of population was self-regulating; and was opposed to the theories of Ricardo and others on the law of diminished returns from the soil and on rent. He was also opposed to any arrangement on the subject of international copyright.

**Carey, WILLIAM, D.D.**, an English orien-

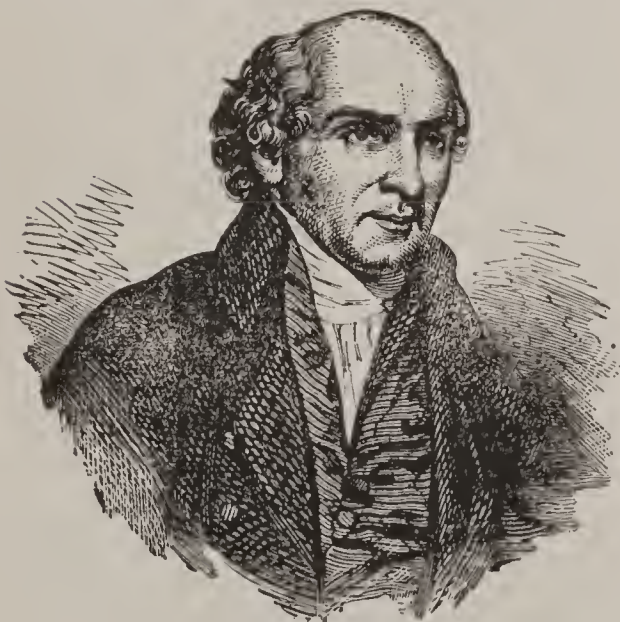

William Carey.

tal scholar and Christian missionary, born in 1761, died at Serampore 1834. He was early apprenticed to a shoemaker, but his

natural turn for languages, and his zeal for the spread of the gospel, were too strong to be overcome. With the little assistance he could procure he acquired Latin, Greek, and Hebrew, and likewise studied theology. In 1786 he became pastor of a Baptist congregation at Moulton, and in 1787 was appointed to a similar situation in Leicester. In 1793 he sailed for the East Indies as a Baptist missionary, and in 1800, in conjunction with Marshman, Ward, and others, he founded the missionary college at Serampore. Here he had a printing-press, and issued various translations of the Scriptures. His first work was a Bengali Grammar. It was followed by the Hitopadesha, in the Mahratta tongue, a Grammar of the Telinga and Carnatic, and a Bengali Lexicon. Under his direction the whole Bible was translated into six, and the New Testament into twenty-one Hindustani dialects. He was long professor of Sanskrit, Mahratta, and Bengali, in Calcutta. His son, **FELIX CAREY**, born in 1786, died 1822, is the author of a Burmese Grammar, and translated several English works into Bengali, Sanskrit, and Burmese.

**Cargill** (-gil'), **DONALD**, a Scottish covenanting preacher, was born about 1610, died 1681. He studied at Aberdeen, and became minister of the Barony Church in Glasgow in 1650. In 1679 he took part in the battle of Bothwell Bridge, where he was wounded. He had a principal hand in the Queensferry and Sanquhar Declarations. For formally excommunicating Charles II., the Duke of York, and others, he was executed at Edinburgh for high treason.

**Cargo**, the goods or merchandise carried by a trading vessel from one place to another. When part of the cargo is on deck it is called the *deck cargo*, as distinguished from the *inboard cargo*.

**Ca'ria**, an ancient country, forming the s.w. corner of Asia Minor, and partly settled in early times by Greek colonists chiefly of the Dorian race. It was included in the dominions of Cræsus, king of Lydia, and on his overthrow by Cyrus was transferred to the Persian monarchy, under whose protection a dynasty of Carian princes was established. About B.C. 129 it was incorporated in the Roman province of Asia. Cnidus, Halicarnassus, and Miletus were among the chief towns.

**Caria'co**, a seaport town, Venezuela, situated to the E. of the Gulf of Cariaco, near the mouth of a river of the same name.

Pop. 7000. The Gulf of Cariaco is 38 miles long, from 5 to 10 broad, from 80 to 100 fathoms deep, surrounded by lofty mountains.

**Car'iacou**, the Virginian deer (*Cervus virginianus*), found in all parts of North America up to 43° N. lat. It is smaller than the common stag, and its colour varies with the season. In spring it is reddish-brown, in autumn slaty-blue, and in winter dull-brown. Written also *Carjacou*.

**Çaria'ma**. See *Seriema*.

**Cariat'ides**. See *Caryatides*.

**Caribbe'an Sea**, that portion of the North Atlantic Ocean lying between the coasts of Central and South America, and the West India Islands. It communicates with the Gulf of Mexico by the Yucatan Channel.

**Car'ibbee Bark**, the bark of the *Exostemma caribæum*, a tree growing in the West Indies, closely allied to Cinchona, and occasionally substituted for the true species of the latter. It is called also *St. Lucia Bark*.

**Car'ibbees**, or LESSER ANTILLES, usually divided into the Windward and Leeward Islands, a section of the West India Islands.

**Car'iboo**, CARIBOU, the name of two American species of reindeer, sometimes regarded as specifically identical with the Old World reindeer. They have never been brought under the sway of man, but are a great object of chase for the sake of their flesh. The woodland cariboo (*Rangifer caribou*) most nearly resembles the common reindeer. It is found over considerable tracts of Canada, as also in Newfoundland and Labrador, and is migratory in its habits. The Barren Ground cariboo (*Rangifer grænländicus*) is much smaller, but has larger horns. It inhabits the Barren Grounds north-west of Hudson Bay, and also extends into Greenland. It executes considerable migrations, going north to the Arctic Ocean in summer, and returning in autumn.

**Car'ibs**, the original inhabitants of the W. Indian Islands, and, when Europeans became acquainted with America, also found in certain portions of Central America and the north of South America. At present only a few remain on Trinidad, Dominica, and St. Vincent.

**Car'ica**. See *Papaw*.

**Car'icature** (It. *caricatura*, from *caricare*, to load, to overcharge), a representation of the qualities and peculiarities of an object, but in such a way that beauties are concealed and peculiarities or defects exaggerated, so

as to make the person or thing ridiculous, while a general likeness is retained. Though a degenerate, it is one of the oldest forms of art. Egyptian art has numerous specimens of caricature, and it has an important place in Greek and Roman art. It flourished in every European nation during the middle ages, and in the present day it is the chief feature in the so-called comic journals. The chief masters of caricature in Britain are Hogarth, Gilray, Rowlandson, Bunbury, John Doyle ('H.B. '), Leech, Richard Doyle, Cruickshank, Tenniel, &c. Punch and Vanity Fair contain the best examples of caricature in contemporary British art.

**Ca'ries** (kā'ri-ēz; L., 'rottenness'), a disease of bone analogous to ulceration in soft tissues. The bone breaks down, or may be said to melt down into unhealthy matter, which works its way to the surface and bursts. Excision of the carious portion of the bone is often effected with good results, but the disease often results in death. *Caries of the teeth* is decay of the dentine or body of the tooth.

**Carignano** (kā-rē-nyä'nō), a town of Italy, 11 miles S. of Turin, left bank of the Po. From this town is named a branch of the house of Savoy. Pop. 4824.

**Car'illon**, a set of bells in a tower or belfry on which tunes may be played.

**Carima'ta**, an island about 50 miles from the coast of Borneo. It is about 10 miles long and rises to a height of 2000 feet. It is visited by Malays, who collect tortoise-shell, tripang, and edible birds' nests.

**Carina'ria**, a genus of gasteropodous molluscs, of the order called Heteropoda or Nucleobranchiata, whose shells are known as Venus' slipper and glass nautilus. The gills are protected by a small and very delicate shell of glassy translucence. The creature itself is about 2 inches in length, and is of oceanic habits. It is so transparent that the vital functions may be watched by the aid of a microscope.

**Carina'tæ** (from L. *carina*, a keel), Huxley's second order of the class Aves or birds, the other two being Saururæ and Ratitæ. The Carinatae include all the living flying birds, that is, all existing birds except the Cursores, and are characterized by the fact that the sternum or breast-bone is furnished with a prominent median ridge or keel, whence the name.

**Cari'ni**, a town of Sicily, 11 miles W.N.W. of Palermo, beautifully situated on river of same name. Pop. 9396.

**Carinth'ia** (German, *Kärnthen*), a western duchy or province of Austria, on the borders of Italy; area, 4006 square miles. It is extremely mountainous, generally sterile, and one of the most thinly populated provinces of Austria. The principal river is the Drave. The iron, lead, and calamine mines are the main sources of its wealth, though there are several manufactories of woollens, cottons, silk stuffs, &c., most of which are in Klagenfurt, the capital. Pop. 1891, 361,008.

**Car'isbrooke**, a village near the centre of the Isle of Wight, and overlooked by the ruins of its ancient castle, where Charles I. was imprisoned thirteen months previous to his trial and execution.

**Caris'simi**, GIOVANNI GIACOMO, an Italian musical composer, born about 1604, died at Rome about 1674. He wrote many oratorios, cantatas, and motets, and occupies an important place in the history of music.

**Car'jacou**. See *Cariacou*.

**Carlen'**, EMILIE, Swedish novelist, born in 1807, died in 1883. She was married to Johan Gabriel Carlen (1814-75), a lawyer and miscellaneous writer. Her graphic pictures of everyday life have secured her a place among the great romance writers of the day. Many of her novels have been translated into Danish, French, German, and English.

**Carleton**, WILLIAM, Irish novelist, born in 1798 at Prillisk, in the county of Tyrone; died at Sandford, near Dublin, 1869. His education commenced at a hedge-school, and terminated with two years' training in an academy kept by a relation, a priest, at Glasslough. Thence he went to Dublin to try his fortune in the walks of literature. There, in 1830-32, were published his *Traits and Stories of the Irish Peasantry*. Among his other publications are: *Fardorougha*, *the Miser*; *The Misfortunes of Barney Brannagan*; *Valentine M'Clutchy*; *The Black Prophet*; *The Tithe Proctor*; *Willey Reilly*; and *the Evil Eye*; this last novel appearing in 1860. He enjoyed a government allowance of £200 per annum several years before his death.

**Car'line-thistle** (*Carlina vulgāris*), a thistle common in dry fields and pastures throughout Britain and the European continent, about a foot in height, with prickly, somewhat hoary leaves, and a purple head of flowers with a straw-coloured involucre.

**Carlisle** (kär-lil'), a parliamentary and municipal borough of England, county town

of Cumberland. It stands at the confluence of the Eden, Caldew, and Petteril, and has been identified with the *Luguvallum* of Antoninus, from which was derived the British name *Caer-Luel*. Sacked by the Danes, it was rebuilt by William Rufus. It was held by the Scots during their tenure of Cumberland, and the Church of St. Mary's was founded by David I., who died here. During the border wars Carlisle underwent many sieges. It surrendered to Charles Edward in 1745. It is a bishop's see. The cathedral, begun in the reign of William Rufus, was partly destroyed by Cromwell in 1648. In the various improvements of the city all the walls, gates, and fortifications have been removed, except a portion of the w. wall, and the castle. The town is somewhat irregularly built, but its principal streets are spacious and well paved. The buildings appropriated to corporate purposes are the town-hall and guild-hall. The courts of justice and the county jail were erected after a design by Smirke, at a cost exceeding £100,000. Carlisle is the seat of various manufactures, of which cotton is the principal. The city sends one member to parliament. Pop. 1891, 39,176.

**Carlisle**, JOHN G., was born in Kenton co., Ky., Sept. 5, 1835. He was admitted to the bar, 1858. Serving seven terms as member of the House, during three being Speaker, proving a dignified officer and skilled parliamentarian, in 1890 he was elected U. S. Senator for Kentucky; in 1893 became a member of President Cleveland's cabinet as Secretary of the Treasury.

**Carlisle**, a town, United States, in Pennsylvania, 114 miles w. Philadelphia. It is the seat of Dickinson Methodist College, founded in 1783. Pop. in 1890, 7620.

**Car'lists**, the name given to the followers of Don Carlos of Bourbon and his descendants. See *Carlos de Bourbon*.

**Carlos'**, DON, Infant of Spain, son of Philip II., born 1545, died 1568. He was deformed in person, of a violent and vindictive disposition, and though originally declared heir to the throne he was afterwards passed over in favour of his cousins Rodolph and Ernest. In consequence of this he is supposed to have entered into a plot against the king and the Duke of Alva. Tried on the charge of conspiring against the life of the king, he was found guilty, and imprisoned, waiting sentence from the king. He died shortly after, presumably murdered, but of this there is no proof. The story of

Don Carlos has furnished the subject of several tragedies, viz. by Otway (English), Schiller (German), and Alfieri (Italian).

**Carlos de Bourbon**, DON MARIA ISIDOR, the second son of Charles IV. of Spain and brother of Ferdinand VII., born 1788, died 1855. He was heir presumptive to the throne until the birth of Maria Isabella in 1830. On the death of his brother he claimed the throne as legitimate king of Spain, and was recognized as such by a considerable party, who excited a civil war in his favour, and thenceforward were designated by the title of *Carlists*. After a course of hostilities extending over several years with varying success he found himself obliged in 1839 to take shelter in France. In the meantime he and his descendants had been formally excluded from the succession by a vote of the Cortes in 1836. In 1845 he resigned his claims in favour of his eldest son, and in 1847 was permitted to take up his abode in Trieste, where he died. His eldest son, Don Carlos (1818-61), married Maria Carolina Ferdinanda, a sister of Ferdinand II., king of Naples. On more than one occasion he endeavoured to excite an insurrection in his favour in his native country, but these attempts were always frustrated. His nephew, Don Carlos, duke of Modena, born 1848, is the present representative of the Carlists. He married the sister of the late Count of Chambord. In 1873 he instigated a rising in the north of Spain, and continued the struggle till after Alfonso XII. came to the throne, when he was defeated and withdrew. See *Spain*.

**Carlovin'gians**, the second dynasty of the French or Frankish kings, which supplanted the Merovingians, deriving the name from Charles Martel or his grandson Charlemagne (that is, Karl or Charles the Great). Charles Martel (715-741) and his son Pepin (741-768) were succeeded by Charlemagne and his brother Carloman (768-771). Charlemagne became sole king in 771, and was succeeded in the Empire of the West by his son Louis le Debonnaire 814. He divided his empire among his sons, and at his death (840) his son Charles the Bald became king of France. He died in 877, and was succeeded by a number of feeble princes. The dynasty came to an end with Louis V., who died in 987.

**Car'low**, an inland county of Ireland, province of Leinster, surrounded by Kildare, Wicklow, Wexford, Kilkenny, and Queen's County. Area, 346 square miles, or 221,294

acres. The chief rivers are the Slaney and Barrow. From the remarkable fertility of its soil it is altogether an agricultural county, producing a great deal of butter, corn, flour, and other agricultural produce for exportation. The county returns one member to parliament. Pop. 40,899.—**CARLOW**, the county town, is on the left bank of the Barrow, 34 miles s.w. of Dublin. It is the principal mart for the agricultural produce of the surrounding country and has flour-mills. There is a Roman Catholic cathedral and divinity college. On a rising ground stand the ruins of the ancient castle of Carlow, still presenting an imposing appearance. Pop. 7185.

**Carlowitz** (kär'lo-vits), a town of Austrian Slavonia, on the Danube, 7 miles s.e. Peterwardein; the centre of a famous wine-growing district. A peace was concluded here in 1699 between Austria, Russia, and Poland, and the Turks. Pop. 5800.

**Carlsbad** (kär'ls'bät; 'Charles's Bath'), a town of Bohemia, famous for its hot mineral springs, and much frequented by visitors from all parts of the world, being useful in diabetes, gout, biliary diseases, &c. Permanent pop. about 11,000.

**Carls'burg** ('Charles's Castle'), a town and fortress of Transylvania, near the Maros, 33 miles n.w. of Hermannstadt, with a fine R. C. cathedral, &c. Pop. 7338.

**Carls'cro'na** ('Charles's Crown'), a fortified seaport at the southern extremity of Sweden, on the Baltic, capital of the län or province of Blekinge or Carlsrona. It stands on several rocky islets connected with one another and with the mainland by bridges. It is the chief Swedish naval station, the harbour being safe and spacious, with fine dock, shipyards, arsenal, &c. It has a considerable export trade in timber, tar, potash, tallow, &c. Pop. 1892, 20,892.

**Carlshamn** (kär'ls'hän; 'Charles's Haven'), a seaport town, Sweden, 27 miles w. Carlsrona, exporting timber and articles of timber. Pop. 6529.

**Carlsruhe** (kär'ls'rö; 'Charles's Rest'), the capital of the Grand-duchy of Baden, 3 miles from the Rhine, laid out in 1715, one of the most regularly-built towns in Europe. The castle of the grand-duke stands as a centre, and from this point a number of streets radiate at regular distances, thus forming a kind of fan. There are many handsome edifices. The court library contains 100,000 volumes; there are also a large public library, several valuable

museums and art collections, a botanic garden, polytechnic school, &c. The industries are active and varied. Pop. 1890, 73,684.

**Carl'stad**, a town, Sweden, on an island in Lake Wener, connected with the mainland by two bridges. Pop. 7737.

**Carlstadt** (kár'l'stát), ANDREAS RUDOLF BODENSTEIN, or, German reformer, born 1480, died 1541. He was appointed professor of theology at Wittenberg in 1513. About 1517 he became one of Luther's warmest supporters. He was excommunicated by the bull against Luther, and was the first to appeal from the pope to a general council. Whilst Luther was at the Wartburg Carlstadt instigated the people and students to the destruction of the altars and the images of the saints, greatly to the displeasure of Luther. In 1524 he declared himself publicly the opponent of Luther, and commenced the controversy respecting the sacrament, denying the bodily presence of Christ in the sacramental elements. This controversy ended in the separation of the Calvinists and Lutherans. After many misfortunes he settled as vicar and professor of theology at Basel, where he died.

**Carlton Club**, a famous political club in Pall Mall, London, the recognized headquarters of the Conservative party. It was founded by the Duke of Wellington in 1831, and held its first meeting in Charles Street, St. James's; removed to Carlton Gardens in 1832; built a club-house in Pall-Mall, 1836; and the present house in 1854.

**Carlyle** (kár-lil'), ALEXANDER, D.D., a Scotch Presbyterian minister, born in Dumfriesshire 1722, died at Inveresk 1805. He became minister of Inveresk in 1747, and was one of the leaders of the Moderate party in the church. He was present at the Porteous riot, served as a volunteer in the '45 rebellion, and was present at the battle of Prestonpans. He was intimate with all the most eminent Scotchmen of the day, and got into trouble with the presbytery for assisting at the production of Home's Douglas. In his old age he wrote an Autobiography, which was not published till 1860. It is a singularly interesting production, both from the vigour and sprightliness of its style and the pictures which it presents of Scottish society in the last century.

**Carlyle**, THOMAS, one of the greatest English writers of the present century, born 4th December, 1795, at Ecclefechan, Dumfriesshire; died at Chelsea, Feb. 5th, 1881. He was the eldest son of James Carlyle, a

mason, afterwards a farmer, and was intended for the church, with which object he was carefully educated at the parish school and afterwards at the burgh school of Annan. In his fifteenth year (in 1810) he was sent to the University of Edinburgh, where he developed a strong taste for mathematics. Having renounced the idea of becoming a minister, after finishing his curriculum (in 1814) he became a teacher for about four years, first at Annan, afterwards



Thomas Carlyle.

at Kirkealdy. In 1818 he removed to Edinburgh, where he supported himself by literary work, devoted much time to the study of German, and went through a varied and extensive course of reading in history, poetry, romance, and other fields. His first literary productions were short biographies and other articles for the Edinburgh Encyclopædia. His career as an author may be said to have begun with the issue in monthly portions of his *Life of Schiller* in the London Magazine, in 1823, this work being enlarged and published separately in 1825. In 1824 he published a translation of Legendre's *Geometry*, with an essay on proportion by himself prefixed. The same year appeared his translation of Goethe's *Wilhelm Meister's Apprenticeship*. He was next engaged in translating specimens of the German romance writers, published in 4 vols. in 1827. In 1827 he married Miss Jane Bailie Welsh, daughter of a doctor at



Haddington, and a lineal descendant of John Knox. After his marriage he resided for a time in Edinburgh, and then withdrew to Craigenputtock, a farm in Dumfriesshire belonging to his wife, about 15 miles from the town of Dumfries. Here he wrote a number of critical and biographical articles for various periodicals; and here was written *Sartor Resartus*, the most original of his works. The writing of *Sartor Resartus* seems to have been finished in 1831, but the publishers were shy of it, and it was not given to the public till 1833–34, through the medium of *Fraser's Magazine*. The publication of *Sartor* soon made Carlyle famous, and on his removal to London early in 1834 he became a prominent member of a brilliant literary circle embracing John Stuart Mill, Leigh Hunt, John Sterling, Julius Charles and Augustus William Hare, F. D. Maurice, &c. He fixed his abode at Cheyne Row, Chelsea, where his life henceforth was mainly spent. His next work of importance was on the French Revolution, published in 1837. About this time, and on one or two subsequent years, he delivered several series of lectures, the most important of these, *On Heroes and Hero-worship*, being published in 1840. Chartism, published in 1839, and *Past and Present*, in 1843, were small works bearing more or less on the affairs of the time. In 1845 appeared his *Oliver Cromwell's Letters and Speeches, with Elucidations*, a work of great research, and brilliantly successful in vindicating the character of the great Protector. In 1850 came out his *Latter-day Pamphlets*. This work was very repulsive to many from the exaggeration of its language, and its advocacy of harsh and coercive measures. He next wrote a life of his friend John Sterling, published in 1851, and regarded as a finished and artistic performance. The largest and most laborious work of his life, *The History of Friedrich II. of Prussia, called Frederick the Great*, next appeared, the first two volumes in 1858, the second two in 1862, and the last two in 1865, and after this time little came from his pen. In 1866, having been elected Lord Rector of Edinburgh University, he delivered an installation address to the students *On the Choice of Books*. While still in Scotland the sad news reached him that his wife had died suddenly in London. This was a severe blow to Carlyle. Mrs. Carlyle, besides being a woman of exceptional intellect, was a most devoted and

affectionate wife. From this time his productions were mostly articles or letters on topics of the day, including *Shooting Niagara*; and *After?* in which he gave vent to his serious misgivings as to the result of the Reform Bill of 1867. An unimportant historical sketch, *The Early Kings of Norway*, appeared in 1874, but was written long before. Towards the end of his life he was offered a government pension and a baronetcy, but declined both. He left the estate of Craigenputtock to the University of Edinburgh, settling that the income from it should form ten bursaries to be annually competed for—five for proficiency in mathematics and five for classics (including English). He had appointed James Anthony Froude his literary executor, who, in conformity with his trust, published *Reminiscences of Thomas Carlyle*, 1881; *Thomas Carlyle: the First Forty Years of his Life*, 1882; *Letters of Jane Welsh Carlyle*, 1883; and *Thomas Carlyle: Life in London*, 1884; *The character of Carlyle presented in these volumes gave an unexpected shock to the public, and a bitter controversy has raged regarding Froude's conduct in the matter. Meantime the reputation of Carlyle has suffered somewhat, though time and further light may reinstate his fame on its former pedestal. Works published to assist in this are, Early Letters of Thomas Carlyle, edited by Ch. E. Norton (1886); and a new edition of the Reminiscences by same editor (1887); Correspondence between Goethe and Carlyle appeared the same year.*

**Carmagnola** (kâr-mâ-nyô'lä), a town of N. Italy, 18 miles s.s.e. of Turin. It has the remains of a strong castle, and is noted for its annual silk fairs. Pop. 13,005.

**Carmagnole** (kâr-mâ-nyöl), a name applied in the early times of the French Republic (1792–93) to a highly-popular song (author and composer unknown), and a dance by which it was accompanied. The appellation afterwards became a sort of generic term for revolutionary songs.

**Carmar'then**, or CAERMAR'THEN, a maritime county, South Wales, the largest of the Welsh counties; area, 594,405 acres, of which about 440,000 are under tillage or permanent pasture. It is of a mountainous character generally, and its valleys are noted for the beauty of their scenery. The principal river is the Tywi or Towy. The mineral products of the county are iron, lead, coal, and limestone. The chief towns are Carmarthen and Llanelly. The county

## CARMARTHEN BAY — CARNARVON.

returns two members to the House of Commons. Pop. 130,574.—**CARMARTHEN**, the county town, is situated 9 miles from the sea, on the Towy, which is navigable to its outlet in Carmarthen Bay. The town is well built, and as some parts of it have a considerable elevation it has a striking appearance when viewed from a distance. There are some tin and lead works, cloth manufactories, and iron-foundries, and the salmon-fishery is extensive. With Llanelly it returns a member to the House of Commons. Pop. 1891, 10,338.

**Carmarthen Bay**, a bay of S. Wales, opening from the Bristol Channel between Giltar Point and Worms Head; 17 miles across the entrance, and 9 miles from the line of entrance to the Towy's mouth.

**Carmel**, a range of hills in Palestine, extending from the Plain of Esdraelon to the Mediterranean, and terminating in a steep promontory on the south of the Bay of Acre. It has a length of about 16 miles, and its highest point is 1850 feet above the sea.—**KNIGHTS OF MOUNT CARMEL**, an order of 100 knights, each of whom could prove at least four descents of nobility by both father and mother, instituted by Henry IV. of France.

**Car'melites**, mendicant friars of the order of Our Lady of Mount *Car-mel*. From probably the 4th century holy men took up their abode as hermits on Mount Carmel in Syria, but it was not till about the year 1150 that pilgrims established an association for the purpose of leading a secluded life on this mountain, and so laid the foundation of the order. Being driven by the Saracens to Europe in 1247 they adopted all the forms of monastic life and a somewhat milder rule. In time they became divided into several branches, one of them distinguished by walking barefooted. They are



Carmelite.

still to be seen in Roman Catholic countries. The habit of the order is of a dark-brown colour, and over it when out of doors they wear a white cloak, with a hood to cover the head.

**Car'minatives**, medicines obtained chiefly from the vegetable kingdom, and used as remedies for flatulence and spasmodic pains. They are said to derive their name from the Latin word *carmen*, a song, a charm, from their often operating almost instantaneously, like a *charm*. They include peppermint, ginger, cardamoms, anise, caraway, &c.

**Car'mine**, the fine red colouring matter or principle of cochineal, from which it is prepared in several ways, the result being the precipitation of the carmine. It is used to some extent in dyeing, in water-colour painting, to colour artificial flowers, confectionery, &c. Other preparations get the same name.

**Carmo'na**, town, Spain, Andalusia, 20 miles E.N.E. of Seville. Among its edifices are a ruined fortress, a Gothic church with a lofty spire, a fine Moorish gateway, &c. Near the town a number of ancient rock-cut tombs have been opened up. Pop. 17,421.

**Carnac**, a village, Brittany, France, dep. of Morbihan, on a height near the coast, 15 miles S.E. of Lorient, and remarkable for the so-called Druidical monuments in its vicinity. These consist of eleven rows of unhewn stones, which differ greatly both in size and height, the largest being 22 feet above ground, while some are quite small. These avenues originally extended for several miles, but many of the stones have been cleared away for agricultural improvements. They are evidently of very ancient date, but their origin is unknown.

**Carnahu'ba**. See *Carnauba*.

**Car'nallite**, a potassic mineral, a double chloride of magnesium and potassium, found at Stassfurt in Prussia, and elsewhere, yielding potassic chloride, which is used as a fertilizing agent, and yields potash salts.

**Carna'ria**. Same as *Carnivora*.

**Carnar'von** or CAERNARVON, a maritime county of North Wales, forming the N.W. extremity of the mainland; area, 369,477 acres. It is traversed by lofty mountains, including the Snowdon range, whose highest peak is 3571 feet, and the highest mountain in South Britain. There are other summits varying from 1500 feet to more than 3000 feet. Lakes are numerous, but the only river of

importance is the Conway, which separates the county from Denbighshire. Slate is the chief mineral, large quantities of which are exported. Although the most mountainous county in Wales there are many tracts of low and fertile land, but the arable area is small. It sends two members to the House of Commons. Pop. 118,225.—**CARNARVON**, the county town, is a seaport and parliamentary borough (joining with Conway, Bangor, Pwllheli, Nevin, and Criccieth), on the s.e. side of the Menai Strait. The old part of the town is surrounded by an ancient wall. The magnificent castle or palace of Edward I., and in which Edward II. was born, stands at the w. end of the town, almost overhanging the sea, and is still externally entire. Carnarvon is a sea-bathing resort, and the shipping trade is considerable. Pop. 1891, 9804.

**Carnat'ic**, the district in South-eastern India extending from Cape Comorin to the Northern Circars, lying east of the Ghats, and reaching to the sea on the Coromandel coast. It is now included in the Presidency of Madras.

**Carna'tion** (from L. *caro*, *carnis*, flesh): in the fine arts, flesh colour; the parts of a picture which are naked or without drapery, exhibiting the natural colour of the flesh.

**Carnation**, the popular name of varieties of *Dianthus Caryophyllus*, the clove-pink. The carnations of the florists are much prized for the beautiful colours of their sweet-scented double flowers. They are arranged into three classes according to colour, viz. *bizarres*, *flakes*, and *picotees*.

**Carnauba** (kár-ná-ö'bá), the Brazilian name of the palm *Corýpha cerifera*, which has its leaves coated with waxy scales, yielding by boiling a useful wax. The fruit and pith are eaten, the leaves are variously employed, and the wood in building.

**Carnegie**, ANDREW, was born at Dunfermline, Scotland, 1835, whence his father, a hand-loom weaver, emigrated to America. The family settled in Pittsburgh, where Andrew obtained employment first as a telegraph messenger. A fortunate acquaintance with Woodruff, the sleeping car patentee, laid the foundation of his success; then came lucky ventures in oil and the starting of a rolling mill from which has grown the largest system of iron and steel industries in the world. Carnegie is a true philanthropist, endowing laboratory in New York, libraries in Dunfermline, Edinburgh,

Ayr, Pittsburgh and other places with gifts sometimes as high as half a million dollars. He has published valuable contributions on the labor question: *An American Four-in-Hand in Britain*; *Round the World*; and *Triumphant Democracy*.

**Carnio'la** (German, *Krain*), a duchy or province of Austria, bounded by Carinthia, Styria, Croatia, and Italy; area, 3856 sq. miles. It is covered with lofty mountains, and, generally speaking, is one of the most unfertile regions of the empire. It is remarkable for its underground rivers, winter lakes, and stalactite caverns. There are iron, lead, and quicksilver mines, and abundance of coal, marble, and valuable stone. Pop. 1891, 498,958. Capital is Laibach.

**Car'nival**, the feast or season of rejoicing before Lent, observed in Catholic countries with much revelry and merriment. The name comes from Low Latin *carnelevāmen*, for *carnis levāmen*, solace of the flesh or body, feasting permitted in anticipation of any fast. Carnival observances have much declined, but in some of the cities of Italy, especially Rome, Milan, and Naples, it is still a great popular festival, as well as in some parts of Germany. Some have thought the carnival mainly a survival of the pagan Saturnalia of the Romans, which it much resembles in many of the usages, and in the tricks and mummeries with which it abounds.

**Carniv'ora**, a term applicable to any creatures that feed on flesh or animal substances, but now applied specially to an order of mammals which prey upon other animals. The head is small, the jaws powerful, and the skin is well covered with hair. Two sets of teeth, deciduous or milk and permanent, are always developed in succession, and in both sets incisors, canines, and molars are distinguishable. The stomach is simple and the alimentary canal short, thus making the body as light and slender as possible for the purpose of hunting and springing on its prey. The muscular activity of the Carnivora is very great, their respiration and circulation very active, and their demand for food is consequently constant. Carnivora are often divided into Plantigrada, comprising the bears, badgers, raccoons, &c.; Digitigrada, comprising lions, tigers, cats, dogs; and Pinnipedia or Pinnigrada, comprising the seals and walruses. The two former divisions are also classed together as Fissipedia. The typical Plantigrada are distinguished by their putting the

whole sole of the foot to the ground in walking, while the Digitigrada walk on the tips of their toes. The Plantigrada are also less decidedly carnivorous, and feed much on roots, honey, and fruits. In the Pinnigrada the body is long and of a fish shape, the fore and hind limbs are short and expanded into broad webbed swimming-paddles. The hind-feet are placed far back, and more or less tied down to the tail by the integuments.

**Carnot** (kär-nō), LAZARE NICOLAS MARGUERITE, a French statesman, general, and strategist, was born in 1753, and died in 1823. When the revolution broke out he was captain in the corps of engineers. In 1791 he was appointed deputy to the constituent assembly. In the following March he was sent to the Army of the North, where he took command, and successfully repulsed the enemy. On his return he was made member of the Committee of Public Safety, and directed and organized the French armies with great ability and success. As a member of the Committee Carnot was formally responsible for the decrees of Robespierre, but being incessantly occupied in his department knew really little of the atrocities to which the sanction of his name was lent. In 1797 Carnot, having unsuccessfully opposed Barras, had to escape to Germany, but returned, and was appointed minister of war by Napoleon (1800). But he remained in principle an inflexible republican, voted against the consulship for life, and protested against Napoleon's assumption of the imperial dignity. In 1814 Napoleon gave him the chief command at Antwerp, and in 1815 the post of minister of the interior. A grandson of his, MARIE FRANÇOIS SADI, born in 1837, was elected president of the French republic in 1887. He was assassinated June 24, 1894, by an Italian anarchist, in the city of Lyons, France, and M. Casimir-Perier was elected to fill the vacant presidency.

**Caro**, ANNIBALE, one of the most celebrated Italian authors of the 16th century, born 1507, died 1566. He was secretary to several members of the great Farnese family. He devoted himself to numismatics and the Tuscan language, and became famous for the purity and elegance of his style. Among his works are Translations of the Æneid and of Aristotle's Rhetoric.

**Carob-tree**, or ALGARROBA-BEAN (*Ceratonia siliqua*), a leguminous plant of the sub-order Cæsalpinieæ, growing wild in all the

countries on the Mediterranean. It has a dark-green foliage, and produces pods in which the seeds are imbedded in a dry nutritious pulp of a sweet taste. The names *locust-beans* and *St. John's bread* have been given to the legumes of this plant, from an idea that they were the food eaten, along with wild honey, by the Baptist in the wilderness. In the south of Europe they are principally used as food for horses, and they are imported into Britain as a food for cattle.

**Car'ol**, a song, especially one expressive of joy. It often signifies, specifically, a religious song or ballad in celebration of Christmas, such as are sung about Christmas-tide in English churches or by 'waits' out of doors.

**Carolina**, NORTH, one of the United States, bounded N. by Virginia, E. by the Atlantic, S. by South Carolina and Georgia, and W. by Tennessee; area, 52,250 sq. miles. The principal rivers are the Roanoke and Chowan, Neuse, Pamlico or Tar, and Cape Fear and Yadkin. The coast is generally difficult of access, being fringed by a line of narrow sandy islands, between which and the mainland the passages are mostly shallow and dangerous. There are three noted capes on the coast, viz. Cape Hatteras, Cape Look-out, and Cape Fear, all dangerous to seamen. North Carolina is generally a dead level for 40 to 60 miles inland, this part largely consisting of cypress swamps; next comes a fine undulating country largely under cultivation or clothed with deciduous trees; lastly comes the region of the Appalachians, with Mt. Mitchell (6707 feet) the highest of all: fine fruits and picturesque scenery are here the characteristics. The mineral resources are highly valuable, including coal and iron in abundance, silver, lead, zinc, emery, &c. Among animals are the wolf, deer, opossum, raccoon, foxes of several kinds, turtles, tortoises, rattlesnake and other snakes, aquatic birds in great abundance. In the level parts the soil generally is but indifferent. On the banks of some of the rivers, however, and particularly the Roanoke, it is remarkably fertile. The more elevated grounds are for the most part remarkably fertile. Cotton is grown in large quantities in the sandy isles and the flat country; rice is also grown largely among the swamps. The chief staples, however, are Indian corn, tobacco, wheat, oats, and sweet-potatoes. The pitch-pine, which grows abundantly in the low districts, is one of the most valuable productions, affording the

## CAROLINA.

pitch, tar, turpentine, and various kinds of lumber, which together constitute about one-half of the exports of North Carolina. There is considerable diversity of climate, as in all the southern states. Intermittent fevers are frequent in the low-lying parts of the country, but the western and hilly parts are very healthy. Education is not in a very advanced state. The chief religious denomination is the Baptists. There are

no large towns, the largest, Wilmington, having only a pop. 1890, of 20,056; Raleigh is the capital. The first attempt to colonize in this part by the English was made in 1587, but the colony was never again heard of. In 1650 emigrants from Virginia, and in 1661 an English colony from Massachusetts, made settlements. In 1720 the two Carolinas were separated into North and South Carolina. In 1861 the state seceded from



A Rice-field in South Carolina.

the Union, and it was not formally restored till 1868. Pop. in 1880, 1,399,750; in 1890, 1,617,947.

**Carolina, SOUTH**, one of the United States, bounded n. by North Carolina, e. by the Atlantic, s.w. and w. by Georgia; area, 30,570 sq. miles. Columbia is the seat of government, but Charleston is much the largest town. The chief rivers are the Great Pedee and the Congaree and Wateree, which unite to form the Santee, together with the Savannah, forming the boundary between South Carolina and Georgia. These and other streams, flowing generally in a s.e. direction, afford an inland navigation to the extent of 2400 miles. There is now also a considerable net-work of railways. The principal harbour is that of Charleston. Numerous small islands along the coast supply the famous Sea-island cotton. In physical constitution South Carolina resembles its northern neighbour, a great level plain of

forest and swamp extending westward from the sea, till it begins 100 miles inward to rise in ranges of sand-hills, and finally reaches ranges of 4000 feet in the Appalachians. In this western district the land is fertile, well cultivated, and watered by considerable streams. The staple products of the state are cotton and rice, of which great quantities are annually exported. The culture of wheat, barley, oats, and other crops has been comparatively neglected. The rice-lands of South Carolina give employment to thousands of coloured people. The low country is subject to fevers, but the upper country enjoys as salubrious a climate as any part of the United States. S. Carolina is rich in minerals, including gold, iron, manganese, copper, lead, granite, limestone, and valuable phosphate-marls. The commerce is considerable, the chief exports being cotton, rice, timber, and naval stores. Education is at a low ebb, there being pro-

portionally more illiterates in this than in any other state. The Baptist is the most numerous of the religious denominations. The first settlement of South Carolina was made by whites at Port Royal about 1670, but a permanent establishment was formed only ten years later by the congregation of a few settlers at Charleston. In 1695 the cultivation of rice was introduced by Governor Smith; that of cotton followed; and on these two staples the colony soon began to flourish. South Carolina was the first of the states to secede from the Union, and it suffered severely in the civil war between North and South, and was the theatre of some of the most remarkable events which it produced. Pop. in 1880, 996,577; in 1890, 1,151,149.

**Carolina-pink**, a name given to the *Spigelia marylandica*, a North American plant bearing scarlet flowers, and having a root used as a vermifuge.

**Caroline**, British queen, was a daughter of the Duke of Brunswick-Wolfenbüttel, born May 17, 1768. In 1795 she was married to the Prince of Wales, afterwards George IV. The marriage was not to his liking, and after the birth of the Princess Charlotte he separated from her. Many reports were circulated against her honour, and a ministerial committee was formed to inquire into her conduct. But the people in general sympathized with her, regarding her as an ill-treated wife. In 1814 she made a journey through Germany, Italy, Greece, &c., to Jerusalem, in which an Italian, Bergami, was her confidant and attendant. When the Prince of Wales ascended the throne in 1820 he offered her an income of £50,000 on condition that she would never return to England. She refused, and in the June of same year entered London amid public demonstrations of welcome. The government now instituted proceedings against her for adultery, but the public feeling and the splendid defence of Brougham obliged the ministry to give up the Divorce Bill after it had passed the Lords. Though banished from the court, the queen now assumed a style suitable to her rank. She died 7th Aug. 1821.

**Caroline Islands**, or **NEW PHILIPPINES**, a large archipelago, North Pacific Ocean, between lat. 3° and 12° N. and lon. 132° and 163° 6' E., and between the Philippines and the Marshall Isles, first discovered by the Spaniards in 1543, if not by the Portuguese in 1525. Many of the islands are mere coral

reefs little elevated above the ocean. They form many groups, the most important being the Pelews, and those to which the largest islands of all, Yap and Ponape, respectively belong. The pop. is estimated at 20,000, made up of inhabitants of different races and stages of civilization. The most important vegetable productions are palms, bread-fruit trees, and bananas. The natives show great skill in constructing their canoes and building their houses. There is an American Protestant and a Roman Catholic mission. Some trade is carried on at Yap and Ponape. The islands are claimed by Spain, and the proposal of Germany to occupy Yap nearly gave rise to a quarrel between the two powers in 1885.

**Carolingian**. See *Carlovingian*.

**Car'olus**, a gold coin struck in the reign of Charles I., and originally 20s. in value, afterwards 23s. The name was given also to various other coins.

**Caro'tid Arteries**, the two great arteries which convey the blood from the aorta to the head and the brain. The *common carotids*, one on either side of the neck, divide each into an external and an internal branch. The *external carotid* passes up to the level of the angle of the lower jaw, where it ends in branches to the neck, face, and outer parts of the head. The *internal carotid* passes deeply into the neck, and through an opening in the skull behind the ear enters the brain, supplying it and the eye with blood. Wounds of the carotid trunks cause almost immediate death.

**Carouge** (kâ-röz), a town of Switzerland, on the Arve, near Geneva, with which it is connected by a bridge. Pop. 5889.

**Carp** (*Cyprinus*), a genus of soft-finned abdominal fish (type of the family Cyprini-



Carp (*Cyprinus carpio*).

nidæ), distinguished by the small mouth, toothless jaws, and gills of three flat rays. They have but one dorsal fin, and the scales are generally of large size. They frequent fresh and quiet waters, feeding chiefly on vegetable matters, also on worms and molluscs. The common carp (*C. carpio*) is olive-green above and yellowish below, and in many parts is bred in ponds for the

use of the table. It sometimes weighs many pounds, is of quick growth, and spawns thrice a year. It is said to live to the great age of 100 or even 200 years. The well-known gold-fish is *C. auratus*, believed to be originally from China.

**Carpaccio** (kár-pách'ō), VITTORE, Italian painter, one of the most celebrated masters of the old Venetian school, was born probably at Venice about 1450-55, and died there after 1521. His distinguishing characteristics are natural expression, vivid conception, correct arrangement, and great variety of figures and costumes. He also excelled as an architectural and landscape painter. His favourite employment was the dramatic representation of sacred subjects, several of which he has illustrated by a series of paintings.

**Carpa'thian Mountains** (German, *Karpathen*), a range of mountains in Southern Europe, chiefly in Austria, forming a great semicircular belt of nearly 800 miles in length. The Carpathian chain may be divided into two great sections—the West Carpathians, in Hungary, to the north-west, and the East Carpathians, in Transylvania, to the south-east, with lower ranges stretching between. To the Western Carpathians belongs the remarkable group of the Tatra. The greatest height of the East Carpathians is Ruska-Poyana, 9909 feet; of the West Carpathians, the Eisthalerspitze, 8521 feet; many other peaks have an elevation over 8000 feet. The outer bend of the Carpathians is much steeper than that which descends towards the valleys of Transylvania and Hungary. The only important rivers which actually rise in the chain are the Vistula, the Dniester, and the Theiss. The Carpathian range is rich in minerals, including gold, silver, quicksilver, copper, and iron. Salt occurs in beds, which have sometimes a thickness of 600 or 700 feet. On the plateaux corn and fruit are grown to the height of 1500 feet. Higher up the mountain steeps are covered with forests of pine. There is much remarkable scenery.

**Car'pel**, in botany, a single-celled ovary or seed-vessel, or a single cell of an ovary or seed-vessel, together with what belongs to that cell, as in many cases a separate style and stigma of the pistil. The pistil or fruit often consists of only one carpel, in which case it is called *simple*; when either consists of more than one carpel it is called *compound*. A carpel is regarded as a modified leaf.

**Carpenta'ria**, GULF OF, a large gulf on the north coast of Australia, having Cape York Peninsula, the northern extremity of Queensland, on the E., and Arnhem Land on the W.

**Carpenter**, WILLIAM BENJAMIN, M.D., LL.D., an English physiologist, born 1813, died 1885. He studied medicine at University College, London, and at Edinburgh University, subsequently held several lectureships in London, and ultimately became registrar at London University (1856-79). He wrote several well-known works on physiology: *Principles of General and Comparative Physiology*; *Principles of Mental Physiology*; *Principles of Human Physiology*; a *Manual of Zoology*, &c. He took a leading part in the expeditions sent out by government in 1868-70 for deep-sea exploration in the North Atlantic. He was chosen president of the British Association at Brighton in 1872.

**Carpenter-bee**, the common name of the different species of hymenopterous insects of the genus *Xylocopa*. The species are

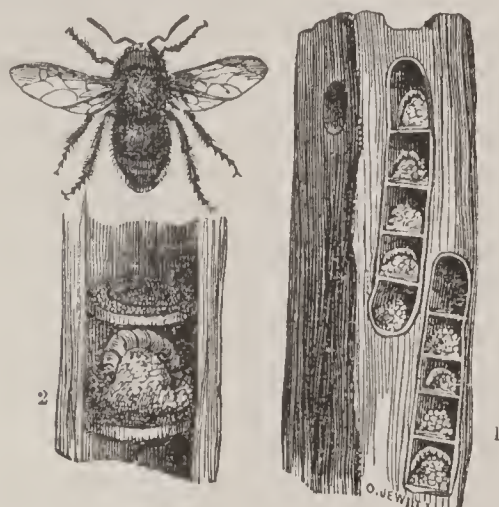

Carpenter-bee (*Xylocopa violacea*), half the natural size.

1, A piece of wood bored by the bee, and grubs and food deposited in the cells. 2, Two of the cells drawn larger in order to show the partitions.

numerous in Asia, Africa, and America, and one species inhabits the south of Europe. They are generally of a dark violet-blue, and of considerable size. They usually form their nests in pieces of half-rotten wood, cutting out various apartments for depositing their eggs.

**Carpentras** (kár-pañ-trä), a town, Southern France, dep. Vaucluse, 14 miles N.E. of Avignon, surrounded by walls flanked with towers. It is an ancient town, and has a Roman triumphal arch, an aqueduct, &c. Pop. 7443.

**Car'pentry** is the art of combining pieces of timber to support a weight or sustain pressure. The work of the carpenter is intended to give stability to a structure, that of the joiner is applied to finishing and decoration. An explanation of some of the terms employed in carpentry may be useful. The term *frame* is applied to any assemblage of pieces of timber firmly connected together. The points of meeting of the pieces of timber in a frame are called *joints*. *Lengthening* a beam is uniting pieces of timber into one length by joining their extremities. When neatness is not required this is done by *fish-ing*, that is, placing a piece of timber on each side of where the beams meet and securing it by bolts passed through the whole. When the width of the beam must be kept the same throughout *scarfing* is employed. This is cutting from each beam a part of the thickness of the timber, and on opposite sides, so that the pieces may be jointed together and bolted or hooped. When greater strength is required than can be produced by a single beam *building* and *trussing* beams are resorted to. Building beams is combining two or more beams in depth so as to have the effect of one. In trussing the beam is cut in two in the direction of its length, and supported with cross-beams, as in roofing. *Mortise* and *tenon* is a mode of jointing timber. An excavation called the mortise is made in one piece, and a projecting tongue to fit it called the tenon in the other. The timber framework of floors is called *naked flooring*, and is *single* if there be but a single series of joists, *double* if there are cross-binding joists, and *framed* if there are girders or beams in addition to the joists. The *roof* is the framework by which the covering of a building is supported. It may consist of a series of sloping pieces of timber, with one end resting on one wall and the other end meeting in a point with a corresponding piece resting on the opposite wall: these are called *rafters*. There is usually a third piece which connects the lower extremities of the rafters and prevents them from spreading. This is called a *tie*, and the whole frame a *couple*. The principal instruments used in carpentry are saws, as the circular-, band-, and tenon-saws; planes, as the jack-plane, smoothing-plane, moulding-plane, &c.; chisels, gouges, brad-awls, gimlets, descriptions of which will be found in their places.

**Carpet**, a thick fabric, generally composed wholly or principally of wool, for covering

the floors of apartments, staircases, and passages in the interior of a house. They were originally introduced from the East, where they were fabricated in pieces, like the modern rugs, for sitting on—a use obviously suggested by the Eastern habit of sitting cross-legged upon the floor. Eastern carpets are still highly thought of in Europe, into which they are largely imported. The Persian, Turkish, and Indian carpets are all woven by hand, and the design is formed by knotting into the warp tufts of woollen threads of the proper colour. Of carpets made in this country and Europe *Brussels* carpet is a common and highly-esteemed variety. It is composed of linen thread and worsted, the latter forming the pattern. The linen basis does not appear on the surface, being concealed by the worsted, which is drawn through the reticulations and looped over wires that are afterwards withdrawn, giving the surface a ribbed appearance. *Wilton* carpets are similar to Brussels in process of manufacture, but in them the loops are cut open by using wires with a knife-edge, and the surface thus gets a pile. *Tapestry* carpets have also a pile surface. They are made in a manner similar to that in which Brussels and Wilton carpets are manufactured; but only one yarn is used instead of five or more of different colours, as in the carpets just named. The *Kidderminster* or *Scotch* carpet consists of two distinct webs woven at the same time and knitted together by the woof. The pattern is the same on both sides of the cloth, but the colours are reversed. An improvement upon this is the three-ply carpeting, made originally at Kilmarnock. The original *Axminster* carpets were made on the principle of the Persian or Turkish carpets. Axminster carpets, made in one piece to suit the size of the room, have a fine pile, which is produced by using chenille as the weft, the projecting threads of which form the pile, which is dyed before being used. Carpets of felted wool, with designs printed on them, are also used, and are very cheap. Philadelphia is the leading carpet-manufacturing city in the United States.

**Carpet-bagger**, a needy political adventurer who goes about the country pandering to the prejudices of the ignorant with the view of getting into place or power, so called because regarded as having no more property than might fill a *carpet-bag*. Originally applied to needy adventurers of the Northern States of America who tried in this way to



gain the votes of the negroes of the Southern States.

**Carpi**, a town of Northern Italy, 9 miles N. of Modena, seat of a bishopric, suffragan to Bologna. Pop. 6500.—It is also the name of a village in the province of Verona, near which Prince Eugene defeated the French in 1701.

**Carpi'nus**. See *Hornbeam*.

**Carpocra'tians**, a sect of Gnostics of the 2d century, so called from *Carpocrates*, a prominent teacher of gnosticism. They maintained that only the soul of Christ went to heaven, that his body would have no resurrection, and that the world was made by angels.

**Car'polites**, a term applied to fossils of the nature of fruits, usually found in the Carboniferous system. Their exact place in the vegetable kingdom has not yet been determined.

**Carpus**, in anatomy, the bones between the forearm and hand, the wrist in man, or corresponding part in other animals.

**Carracci** (kár-rách'ē), LUDOVICO, AGOSTINO, and ANNIBALE, the three founders of the Bologna, or, as it has been called, the eclectic school of painting.—LUDOVICO (lō-do-vē'kō) was born in 1555 at Bologna. At Florence he studied under Andrea del Sarto, and afterwards went to Parma for the purpose of studying Correggio, who was then imitated by almost all the Florentine painters. He then set up a studio in Bologna, and established a school of painting characterized particularly by its attention to composition and its principle of eclecticism, or endeavour to imitate and unite the chief excellencies of different great masters, the drawing of Raphael, the colouring of Titian, &c. To assist him Ludovico had his two younger cousins, Agostino and Annibale, educated as artists; and after the completion of their studies all three by their able work soon made a high reputation for the academy of the Carracci at Bologna. Ludovico has left many works, the finest of which are in the Pinacoteca at Bologna. He died in 1619.—AGOSTINO (â-gos-tē'nō) was born in 1558 at Bologna; he died at Parma in 1601. He engraved more pieces than he painted, though some of his pictures were admired by contemporaries even more than those of his brother Annibale.—ANNIBALE (ân-nib'âlā) was born in 1560 at Bologna. In 1600 he was invited by Cardinal Farnese to Rome, where the influence of Raphael and Michael Angelo's work tempered the char-

acteristics he had acquired from the Lombard and Venetian schools. His chief work is the series of frescoes for the Farnese Palace at Rome, which kept him eight years. He is generally considered the greatest of the Carracci. He died at Rome in 1609.

**Carrageen, Carragheen** (kar'ra-gēn), *Chondrus crispus*, a sea-weed very common on rocks and stones on every part of the coast of Britain. It is a very variable weed, with a flat branching frond usually of a deep purple-brown colour. When dried it becomes whitish, and in this condition is known as Irish-moss, and is used for making soups, jellies, size, &c. The name comes from Carragaheen, near Waterford, Ireland, where it abounds.

**Carra'ra**, a city of Northern Italy, 59 miles s.w. of Modena, a few miles from the coast, with some interesting buildings, including an old church, an academy of sculpture, &c. It is surrounded by hills which contain fine white statuary marble, in the preparation of which and commoner sorts most of the inhabitants are occupied. Pop. 11,869.—The Carrara marble is the variety generally employed by statuaries. It was formerly supposed to be a primitive limestone, but is now considered an altered limestone of the Oolitic period. Although the Carrara quarries have been worked for 2000 years, having furnished the material for the Pantheon at Rome, the supply is still practically inexhaustible. They employ 6000 or 7000 men.

**Car'rel**, ARMAND, French republican writer, born in 1800. For some years he was an officer in the army, but latterly settled in Paris, and acquired a reputation as an essayist and contributor to the leading opposition papers. In 1827 he published a history of the English Revolution of 1688, and in 1830 united with Thiers and Mignet in editing the *National*, which soon rose to be the leading newspaper in opposition to the government of Charles X. After the revolution his colleagues joined the government of Louis Philippe, and he was left with the chief direction of the paper, which still continued in opposition. In 1832 the *National* became openly republican, and enjoyed great popularity. Carrel was killed in 1836 in a duel with Emile de Girardin.

**Carrhæ**, the site of an ancient city in North-western Mesopotamia, the Haran of the Bible.

**Carriage**, a general name for a vehicle, but more especially for one of the lighter

and more ornamental kind. See *Coach*, where the chief kinds are referred to.

**Carriage Dog.** See *Coach Dog*.

**Carrical.** See *Karikal*.

**Carrick**, the southern district of the county of Ayr, Scotland. The Prince of Wales bears the title of Earl of Carrick.

**Carrickfergus**, seaport of Ireland, co. Antrim, formerly a parliamentary borough, 11 miles by railway N.E. of Belfast. It is memorable as the landing-place of King William III., 14th June, 1690. The castle stands upon a rock projecting into the bay, and is still maintained as a fortress. There are some manufactures, principally linen, and extensive fisheries. Pop. 10,009.

**Carrick-on-Suir**, a town, Ireland, county Tipperary, 85 miles S.W. of Dublin, on the left bank of the Suir, navigable here by small vessels, it has a considerable trade in agricultural produce. Pop. 6583.

**Car'rier** is a person who undertakes to transport the goods of other persons from place to place for him. Persons who undertake this as a systematic business are called *common carriers*, and come under special legal regulations, such as that they shall be responsible for the goods intrusted to them so long as in their custody.

**Carrier** (kâr-yā), JEAN BAPTISTE, an infamous character of the first French revolution, born 1746, executed 1794. Though an obscure attorney at the beginning of the revolution, he was chosen, in 1792, member of the national convention. In Oct. 1793 he was sent to Nantes to suppress the civil war, and to finally put down the Vendéans. The prisons were full; there was dearth of provisions, and Carrier determined to lessen the 'useless mouths' by summary measures. He first caused ninety-four priests to be conveyed to a boat with a perforated bottom, under pretence of transporting them, but instead they were drowned by night. This artifice was repeated a number of times, while Carrier also caused multitudes of prisoners to be shot without any pretence of trial. The executioners, it is said, sometimes amused themselves by tying together a young man and woman, and then drowning them; and they called these murders 'republican marriages.' Some months before the fall of Robespierre, Carrier was recalled. On the 9th Thermidor (July 27), 1794, he was apprehended and brought before the revolutionary tribunal, which condemned him to death, and the guillotine did its work.

**Carrier Pigeon**, a variety of the common domestic pigeon used for the purpose of carrying messages. Several varieties are thus employed, but what is distinctively called the carrier pigeon is a large bird with long wings, large tuberculated mass of naked skin at the base of the beak, and with a circle of naked skin round the eyes. This variety, however, is rather a bird for show than use, and the variety generally employed to carry messages more resembles an ordinary pigeon. The practice of sending letters by pigeons belongs originally to eastern countries, though in other countries it has often been adopted, more especially before the invention of the electric telegraph. An actual post-system in which pigeons were the messengers was established at Bagdad by the Sultan Nureddin Mahmud, who died in 1174, and lasted till 1258, when Bagdad fell into the hands of the Mongols, and was destroyed by them. These birds can be utilized in this way only in virtue of what is called their 'homing' faculty or instinct, which enables them to find their way back home from surprising distances. But if they are taken to the place from which the message is to be sent and kept there too long, say over a fortnight, they will forget their home and not return to it. They are better to get some training by trying them first with short distances, which are then gradually increased. The missive may be fastened to the wing or the tail, and must be quite small and attached so as not to interfere with the bird's flight. By the use of microphotography a long message may be conveyed in this way, and such were received by the besieged residents in Paris during the Franco-Prussian war of 1870-71, the birds being conveyed out of the city in balloons. Seventy-two miles in two and a half hours, a hundred and eighty in four and a half, have been accomplished by carrier pigeons. Large numbers of these birds are now kept in England, Belgium, France, &c., there being numerous pigeon clubs which hold pigeon races to test the speed of the birds. These pigeons are also kept in several European countries for military purposes.

**Carrion-crow**, in Britain the common crow (*Corvus corōne*), so called because it often feeds on carrion. In America the name is given to a small species of vulture called the Black Vulture.

**Carrion-flowers**, a common name for species of the genus *Stapelia* (natural order Asclepiadaceæ), so called because of their

putrid odour. In America the name is also given to the *Smilax herbacæa* a liliaceous plant.

**Car'ron**, a village of Scotland, in Stirlingshire, 2 miles from Falkirk, celebrated for its extensive iron-works, begun in 1760. Pop. 902.—The river of same name falls into the Forth at Grangemouth after an E. course of about 17 miles.

**Carronade**, an iron gun introduced in 1779 by the director of the Carron Foundry (see above), from which it took its name. They were of large calibre, but short and much lighter than common cannon. They were of great service in close naval engagements, but they had a very short range.

**Carron-oil**, a term for a liniment composed of linseed-oil and lime-water, so called from being much used in the case of burns at the Carron Ironworks.

**Carrot** (*Daucus Carōta*), a biennial umbelliferous plant. In gardens there are three chief varieties. The leaves are tri-pinnate, of a handsome feathery appearance. The plant rises to the height of 2 feet, and produces white flowers. The root, in its wild state, is small, tapering, of a white colour, and strong-flavoured; but that of the cultivated variety is large, succulent, and of a red, yellow, or pale straw-colour, and shows remarkably the improvement which may be effected by cultivation. It is cultivated for the table and as a food for cattle. Carrots contain a large proportion of saccharine matter, and attempts have been made to extract sugar from them. They have been also employed in distillation: 10 lbs. weight of carrots will yield about half a pint of very strong ardent spirit—The Peruvian carrot is *Aracācha esculenta*. See *Aracacha*.

**Carrot-fly** (*Psila rosæ*), a fly the larvæ of which are injurious to carrots.

**Carrousel** (kâr'ö-zel), a name given in the middle ages to a tilting match or other occasion when knightly exercises, such as riding at the ring, throwing the lance, were publicly engaged in. They were superseded by tournaments, but were again revived when the latter had fallen out of use, and were frequent at the court of Louis XIV. This name is also given to hobby-horses moving on a circular rotary frame.

**Carrying-trade**, that department of trade or commerce which consists in the carriage of commodities from one place or country to another; generally applied to the carrying of merchandise from one country to another by sea, especially when the vessels conveying

the goods belong to a different country from either of the other two.

**Carse**, a word of uncertain origin, applied in Scotland to a tract of fertile alluvial land along the side of a stream.

**Carson City**, a town, U. States, capital of the state of Nevada, picturesquely situated near the foot of the Sierra Nevada, 3 miles from Carson River; founded in 1858. Pop. 1890, 3950.

**Carstairs**, or **CARSTARES**, **WILLIAM**, a Scottish divine of political eminence, born in 1649 near Glasgow, died 1715. He studied at the University of Edinburgh, and afterwards at Utrecht. He was introduced to the Prince of Orange, on whom he made a favourable impression. In 1672 he came to London, and two years after he was arrested on account of his connection with the exiles in Holland, and was kept five years a prisoner in Edinburgh Castle. He was released in 1679, and afterwards played a part of some importance in the schemes of those who were working in favour of William of Orange. Though he did not approve of it he became privy to the Rye-house plot, in consequence of which he was apprehended and subjected to the torture, which he endured with great firmness. Being released he returned to Holland, and was received by the Prince of Orange as a sufferer in his cause. His scholarship, sagacity, and political information won for him the confidence of William, who planned the invasion of 1688 mainly by his advice. When William was settled on the throne Carstairs was constantly consulted by him on Scotch affairs. He was the chief agent between the Church of Scotland and the court, and was very instrumental in the establishment of Presbyterianism, to which William was averse. On the death of William he was no longer employed on public business, but Anne retained him as her chaplain royal, and made him principal of the University of Edinburgh. When the union of the two kingdoms was agitated he took a decided part in its favour. He was repeatedly moderator of the General Assembly of the Church. His countrymen have mostly looked upon him as an enlightened patriot.

**Cart**, a carriage with two wheels, with or without springs, fitted to be drawn by one horse, and used for carrying goods, or as a vehicle for conveying persons.

**Cartagena** (kâr-tâ-hâ'nâ), or **CARTHAGENA** (kâr-thă-jē'na), a fortified town and seaport

of Spain, in the province of and 31 miles s.s.e. Murcia; with a harbour which is one of the largest and safest in the Mediterranean, sheltered by lofty hills. The town is surrounded by a wall; the principal streets are spacious and regular. When Spain was in a more flourishing condition Cartagena carried on a more extensive commerce than now, having also a greater population. It is still a naval and military station, with an arsenal, dockyards, &c. Lead smelting is largely carried on; and there are in the neighbourhood rich mines of excellent iron. Esparto grass, lead, iron ore, oranges, &c., are exported. Formerly very unhealthy, it has been greatly improved by draining. Cartagena was founded by the Carthaginians under Hasdrubal about 243 B.C., and was called New Carthage. It was taken by Scipio Africanus B.C. 210, and was long an important Roman town. It was ruined by the Goths, and revived in the time of Philip II. Pop. 1887, 84,171.

**Cartagena** (kâr-tâ-hâ'nâ), or **CARTHAGENA** (kâr-tha-jé'na), a city and seaport, Republic of Colombia, on the Caribbean Sea, capital of the state of Bolivar, well laid out, with well-paved streets and a naval arsenal. The exports are coffee, cotton, ivory-nuts, rubber, hides, &c. The trade, which had partly gone to Sabanilla and Santa Marta, is being again recovered since the reopening of the canal to the Magdalena. Pop. 20,000.

**Carta'go**, a town of Central America, in Costa Rica. It formerly had a pop. of about 37,000, but was utterly ruined by an earthquake in connection with an eruption of a neighbouring volcano in 1841, so that its population has decreased to 6000.

**Carta'go**, a town in Colombia, in the valley of the Cauca, in a well-cultivated district and with a good trade. Pop. 8000.

**Carte**, **THOMAS**, an English historian, born in Warwickshire in 1686, died in 1754. He studied at Oxford and Cambridge, took the degree of M.A. at the latter, and entered the church. Having incurred the suspicion of having been concerned in plots against the government he fled to France and remained abroad for some years, returning in 1728. In 1736 he published *Life of James, Duke of Ormonde* (2 vols.

folio), and in 1747-52 three vols. of his voluminous *History of England*, a fourth being published in 1755. His work is distinguished by careful and elaborate research, and has supplied Hume and other historians with much material.

**Carte-blanc**e (kârt-blâ'ns; literally *white* or *blank paper*), a blank paper duly signed, intrusted to a person to fill up as he pleases, and thus giving unlimited power to decide.

**Carte-de-visite** (kârt-dé-vi-zēt'), literally

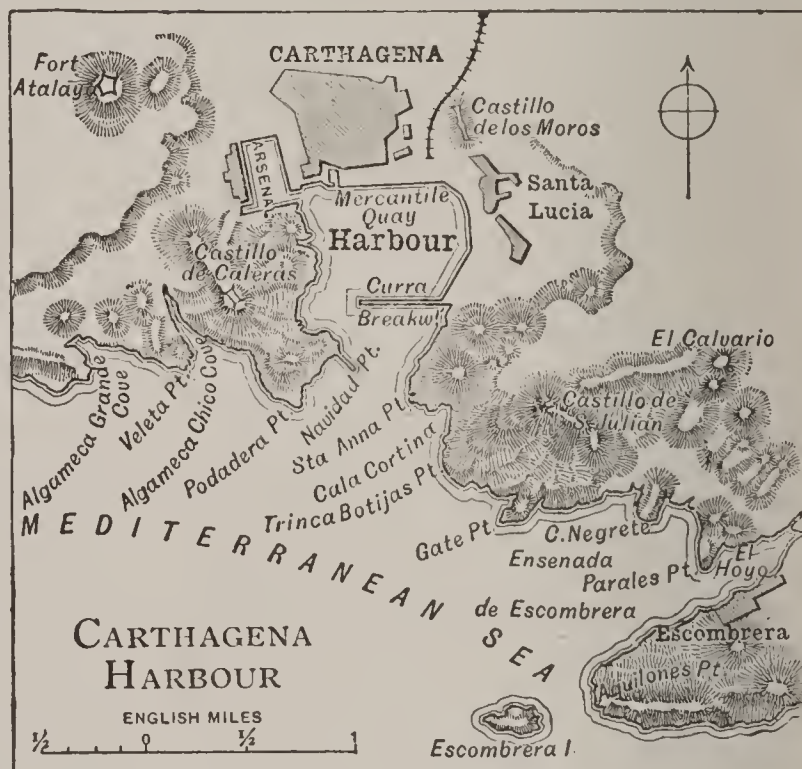

a visiting card, a name applied to a size of photographs somewhat larger than a visiting card, and usually inserted in a photographic album. *Cartes-de-visite* were introduced by Disdéri in 1854.

**Car'tel**, an agreement for the delivery of prisoners or deserters; also, a written challenge to a duel.—*Cartel-ship*, a ship commissioned in time of war to exchange prisoners.

**Carter**, **ELIZABETH**, an English lady of great learning, the daughter of Dr. Nicholas Carter, a clergyman in Kent, was born in 1717, died in 1806. She was educated by her father, and learned Latin, Greek, French, and German; to which she afterwards added Italian, Spanish, Portuguese, Hebrew, and Arabic. She wrote poems, contributed two papers to the *Rambler*; translated the critique of Crousaz on Pope's *Essay on Man*; Algarotti's explanation of Newton's *Philosophy for ladies*; and *Epictetus*; and was a friend of Johnson, Reynolds, Burke, and other eminent men of the time.

**Carte'sian Diver**, a hydrostatic toy consisting of a little hollow glass figure, which has a small opening some distance below the top, and is rather lighter than an equal column of water, so as to be able to float. The figure is placed in a bottle or cylindrical vessel of water, closed with a piece of bladder or india-rubber so as to exclude air. On pressing this with the finger the air inside the figure is compressed, it sinks down, and from the introduction of a small quantity of water becomes specifically heavier. By removing the pressure the water is expelled, and the figure, thus lightened, again rises to the surface.

**Cartesian Philosophy.** See *Descartes*.

**Cartesian Vortices.** See *Descartes*.

**Carthage** (L. *Carthago*, Gr. *Karchēdōn*), the most famous city of Africa in antiquity, capital of a rich and powerful commercial republic, situated in the territory now belonging to Tunis. Carthage was the latest of the Phœnician colonies in this district, and is supposed to have been founded by settlers from Tyre and from the neighbouring Utica about the middle of the 9th century before Christ. The story of Dido and the foundation of Carthage is mere legend or invention. The history of Carthage falls naturally into three epochs. The first, from the foundation to 410 B.C., comprises the rise and culmination of Carthaginian power; the second, from 410 to 265 B.C., is the period of the wars with the Sicilian Greeks; the third, from 265 to 146 B.C., the period of the wars with Rome, ending with the fall of Carthage.

The rise of Carthage may be attributed to the superiority of her site for commercial purposes, and the enterprise of her inhabitants, which soon acquired for her an ascendancy over the earlier Tyrian colonies in the district, Utica, Tunis, Hippo, Septis, and Hadrumetum. Her relations with the native populations, Libyans and nomads, were those of a superior with inferior races. Some of them were directly subject to Carthage, others contributed large sums as tribute, and Libyans formed the main body of infantry as nomads of cavalry in the Carthaginian army. Besides these there were native Carthaginian colonies, small centres and supports for her great commercial system, sprinkled along the whole northern coast of Africa, from Cyrenaica on the east to the Straits of Gibraltar on the west.

In extending her commerce Carthage was

naturally led to the conquest of the various islands which from their position might serve as entrepôts for traffic with the northern shores of the Mediterranean. Sardinia was the first conquest of the Carthaginians, and its capital, Caralis, now Cagliari, was founded by them. Soon after they occupied Corsica, the Balearic, and many smaller islands in the Mediterranean. When the Persians under Xerxes invaded Greece the Carthaginians, who had already several settlements in the west of Sicily, co-operated by organizing a great expedition of 300,000 men against the Greek cities in Sicily. But the defeat of the Carthaginians at Himera by the Greeks under Gelon of Syracuse effectually checked their further progress (480 B.C.). The war with the Greeks in Sicily was not renewed till 410. Hannibal, the son of Gisco, invaded Sicily, reduced first Selinus and Himera, and then Agrigentum. Syracuse itself was only saved a little later by a pestilence which enfeebled the army of Himilco (396). The struggle between the Greeks and the Carthaginians continued at intervals with varying success, its most remarkable events being the military successes of the Corinthian Timoleon (345-340) at Syracuse, and the invasion of the Carthaginian territory in Africa by Agathocles B.C. 310. After the death of Agathocles the Greeks called in Pyrrhus, king of Epirus, to their aid, but notwithstanding numerous defeats (B.C. 277-5), the Carthaginians seemed, after the departure of Pyrrhus, to have the conquest of all Sicily at length within their power. The intervention of the Romans was now invoked, and with their invasion, B.C. 264, the third period of Carthaginian history begins. The first Punic war (L. *Punicus*, Phœnician), in which Rome and Carthage contended for the dominion of Sicily, was prolonged for twenty-three years, B.C. 264 to 241, and ended, through the exhaustion of the resources of Carthage, in her expulsion from the island. The loss of Sicily led to the acquisition of Spain for Carthage, which was almost solely the work of Hamilcar and Hasdrubal. The second Punic war, arising out of incidents connected with the Carthaginian conquests in Spain, and conducted on the side of the Carthaginians by the genius of Hannibal, and distinguished by his great march on Rome and the victories of Lake Trasimene, Trebia, and Cannæ, lasted seventeen years, B.C. 218 to 201, and after just missing the overthrow of

Rome, ended in the complete humiliation of Carthage. (See *Rome, Hannibal*.) The policy of Rome in encouraging the African enemies of Carthage occasioned the third Punic war, in which Rome was the aggressor. This war, begun B.C. 150, ended B.C. 146, in the total destruction of Carthage.

The constitution of Carthage, like her history, remains in many points obscure. The name of king occurs in the Greek accounts of it, but the monarchical constitution, as commonly understood, never appears to have existed in Carthage. The officers called kings by the Greeks were two in number, the heads of an oligarchical republic, and were otherwise called Suffetes, the original name being considered identical with the Hebrew *Shofetim*, judges. These officers were chosen from the principal families, and were elected annually. There was a senate of 300, and a smaller body of thirty chosen from the senate, sometimes another smaller council of ten. In its later ages the state was divided by bitter factions, and liable to violent popular tumults. After the destruction of Carthage her territory became the Roman province of Africa. Twenty-four years after her fall an unsuccessful attempt was made to rebuild Carthage by Caius Gracchus. This was finally accomplished by Augustus, and Roman Carthage became one of the most important cities of the empire. It was taken and destroyed by the Arabs in 638. The religion of the Carthaginians was that of their Phœnician ancestors. They worshipped Moloch or Baal, to whom they offered human sacrifices; Melkart, the patron deity of Tyre; Astarte, the Phœnician Venus, and other deities, which were mostly propitiated by cruel or lascivious rites.

**Carthagena.** See *Cartagena*.

**Carthage**, the seat of Jasper Co., Mo., the centre of the rich lead regions of S. W. Mo.; has numerous factories, 2 parks, a public library, a bank and 4 papers. Pop. 1890, 7981.

**Car'thamus.** See *Safflower*.

**Carthu'sians**, a religious order instituted by St. Bruno (see *Bruno*), who, about 1084, built several hermitages 4 leagues from Grenoble in S. E. France, and, with six companions, united the ascetic with the monastic life. They practised the greatest abstinence, wore coarse garments, and ate only vegetables and the coarsest bread. From their original seat (*La Chartreuse*)

they were called *Carthusians*. Their fifth general, Guigo (died 1137), prescribed, besides the usual monastic vows, eternal silence and solitude. In the following centuries they received additional statutes, which forbade altogether the eating of flesh, and allowed them to speak only during certain hours on Thursdays and the days on which the chapter met. With increasing wealth some modifications were introduced in their silent and solitary life. Their habit is a hair-cloth shirt, a white tunic, a black cloak, and a cowl. The Carthusians were introduced into England about 1180, and built the Charterhouse (a name corrupted from *Chartreuse*) in 1371. Their chief convent is still La Grande Chartreuse. See *Chartreuse*.



Carthusian Monk.

their chief convent is still La Grande Chartreuse. See *Chartreuse*.

**Cartier**, SIR GEORGE ÉTIENNE, Canadian statesman, born at St. Antoine, Quebec, in 1814; died in England in 1873. He was admitted to the bar in 1835, took part in the rebellion of 1837, and had for a time to leave Canada. In 1848 he entered the Canadian parliament, and in 1855 became provincial secretary. Next year he became attorney-general for Lower Canada, in which post he was active in behalf of legal reforms. In 1857 he was a member of the Macdonald ministry, and in 1858 he himself became premier, remaining in this position till 1862. He was active in bringing about the establishment of the Dominion of Canada in 1867, and held a post in the first Dominion cabinet. The following year he received a baronetcy.

**Cartier** (kär-tyä), JACQUES, a French navigator, born at St. Malo 1494, time of death not known. He commanded an expedition to North America in 1534, entered the Straits of Belle Isle, and took possession of the mainland of Canada in name of Francis I. Next year he sailed up the St. Lawrence as far as the present Montreal. He subsequently went to found a settlement in Canada, and built a fort near the site

of Quebec. He was ennobled by the King for his discoveries. Died 1554 (?).

**Car'tilage**, or **GRISTLE**, a firm and very elastic substance occurring in vertebrate animals. When cut, the surface is uniform, and contains no visible cells, cavities, nor pores, but resembles the section of a piece of glue. It enters into the composition of parts whose functions require the combination of firmness with pliancy and flexibility, the preservation of a certain external form with the power of yielding to external force or pressure. The ends of bones entering into the formation of a joint are always coated with cartilage. *Temporary cartilages* are those from which bones are formed by ossification. The *permanent cartilages* are of various kinds. They are found in the external ear and aid in forming the nose, the larynx, &c.

**Cartilaginous fishes** (*laj'i-nus*), a general designation for those fishes whose skeleton consists of cartilage instead of bone, and which comprise the sharks and skates or rays. See *Chondropterygii*.

**Cartoon'**, in painting, a drawing on stout paper or other material, intended to be used as a model for a large picture in fresco, a process in which it is necessary to complete the picture portion by portion and in which a fault cannot afterwards be easily corrected. The cartoon is made exactly the size of the picture intended, and the design is transferred to the surface to be ornamented by tracing or other processes. Cartoons executed in colour, like paintings, are used for designs in tapestries, mosaics, &c. The most famous are those painted by Raphael for the Vatican tapestries, seven of which are still preserved in the South Kensington Museum, London. The subjects of the seven are: 1, Paul Preaching at Athens; 2, The Death of Ananias; 3, Elymas the Sorcerer Struck with Blindness; 4, Christ's Charge to Peter; 5, The Sacrifice at Lystra; 6, Peter and John Healing the Cripple at the Beautiful Gate of the Temple; 7, The Miraculous Draught of Fishes. In modern times the term is also applied to a pictorial sketch relating to some notable character or events of the day.

**Cartouche** (*kär'tösh*), (1) in architecture, a sculptured ornament in the form of a scroll unrolled, often appearing on the cornices of columns, used as a field for inscriptions, &c.—(2) In heraldry, a sort of oval shield, much used by the popes and secular princes in Italy, and others, both clergy and laity,

for painting or engraving their arms on.—(3) The name given to that oval ring or border which includes, in the Egyptian hieroglyphics, the names of persons of high

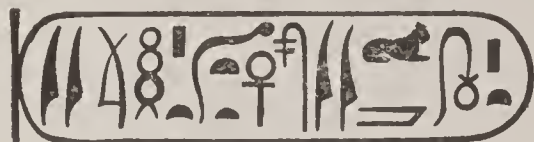

Cartouche.

distinction. The annexed cut shows a cartouche of one of the Ptolemies, kings of Egypt, with the inscription, 'Ptolemy eternal beloved of Phtah.'

**Car'tridge**, a case of paper, parchment, or flannel suited to the bore of fire-arms, and holding the exact charge, including, in the case of small arms, both powder and bullet (or shot). In loading with the old style of cartridge for muzzle-loading rifles, the paper over the powder was bitten or twisted off and the powder poured in, the bullet being then inserted and rammed home. The cartridges used for breech-loading rifles contain the powder in a case of solid brass, and have the percussion-cap by which they are ignited fixed in the base. Such cases can be refilled and used a number of times in succession. Cartridges for shot-guns are similar to those for rifles, but are usually of less solid construction, being commonly of strong paper with a base of metal. Those for large guns are usually made of flannel and contain only the powder. Blank-cartridge is a cartridge without ball or shot. Cartridges for blasting are filled with dynamite or other explosive.

**Cartridge-paper**, a thick sort of paper originally manufactured for soldiers' cartridges, but extensively used in the arts—its rough surface giving it an advantage for drawing upon—and for other purposes.

**Cartwright**, **EDMUND**, the inventor of the power-loom, was born in 1743 in Nottinghamshire. He was educated at Oxford, and took orders in the church. In 1785, he brought his first power-loom into action. Although much opposed both by manufacturers and workmen, it made its way, and in a developed and improved form is now in universal use. Cartwright spent much of his means in similar inventions, and fell into straitened circumstances, from which a parliamentary grant of £10,000 relieved him. He died in 1823.

**Cartwright**, **THOMAS**, one of the eminent Puritan divines of the 16th century, born

in Hertfordshire in 1535, died in 1603. He suffered imprisonment and exile more than once for his nonconformist opinions. He was a learned man, and at one time professor of divinity at Cambridge.

**Car'ucate**, formerly as much land as one team could plough in the year. The size varied according to the nature of the soil and practice of husbandry in different districts.

**Ca'rum**. See *Caraway*.

**Car'uncle**, a fleshy excrescence on the head of a fowl, as the comb of a cock, the wattles of a turkey.

**Caru'pano**, seaport of Venezuela, on the peninsula of Paria. Pop. 12,389.

**Carus** (kä'rūs), KARL GUSTAV, German physician and physiologist, born at Leipzig 1789, died at Dresden 1869. He became professor of midwifery at the Medical Academy, and then royal physician, being latterly a privy-councillor. He published a great number of writings covering a wide field of science, including medicine, physiology, anatomy, psychology, physics, painting, besides memoirs of his life.

**Carvel-built**, a term applied to a ship or boat the planks of which are all flush and not overlapping, as in clincher-built boats.

**Carvin** (kär-van), or CARVIN EPINAY, a town of France, dep. of Pas de Calais; industries: coal-mining, iron-founding, distilling, beet-root sugar, flax-spinning, &c. Pop. 6528.

**Carving**, as a branch of art, is the process of cutting a hard body by means of a sharp instrument into some particular shape, and is a term generally employed in speaking of figures cut out in ivory or wood, in contradistinction to sculpture, or figures produced in stone or metal. The art of carving is of the highest antiquity. Even among the most uncivilized tribes, rudely-carved representations in wood are common. In the early and middle ages wood-carving became general for the decoration of Christian churches and altars. One of the latest developments of the art of carving is the modern invention of carving by machinery. A machine patented in 1845 by Mr. Jordan is capable of copying any carved design that can be produced, so far as that is possible, by revolving tools; the finish is afterwards given by hand-labour.

**Cary**, REV. HENRY FRANCIS, the translator of Dante, was born in 1772, and educated at Oxford. In 1797 he received the vicarage of Abbot's Bromley, Staffordshire. In 1805 appeared his translation of Dante

in English blank-verse. He subsequently translated the Birds of Aristophanes and the Odes of Pindar. In 1826 he was appointed assistant librarian in the British Museum, and retired in 1837 on a pension of £200 a year. He died in London 14th August, 1844.

**Cary**, LUCIUS. See *Falkland*.

**Ca'rya**, the hickory genus of plants.

**Caryat'ides** (-dēz), or CAR'YATIDS, in architecture, figures of women dressed in long robes, serving to support entablatures. Vi-

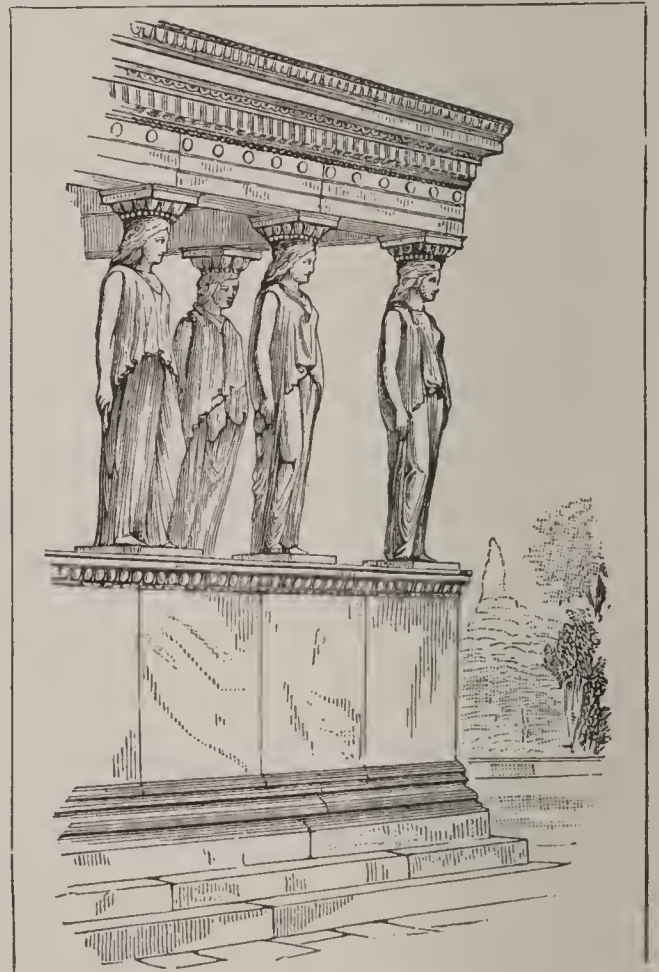

Caryatides.

truvius relates that the city Caryæ sided with the Persians after the battle of Thermopylæ, and that it was on that account sacked by the other Greeks, who took their wives captive, and to perpetuate this event erected trophies in which figures of women dressed in the Caryatic manner were used to support entablatures. This story is, however, believed to be unworthy of credit, although it seems to be not improbable that the idea and name of the Caryatides were derived from this city. Corresponding male figures are called *Atlantes* (which see).

**Car'yocar**, a genus of plants, nat. order Rhizobolaceæ, consisting of lofty trees, na-



tives of tropical America, which produce good timber, and also *souari* or butter-nuts.

**Caryophylla'ceæ**, an order of plants, of which the pink, named formerly *Car. ophyllus*, and now *Dianthus*, may be considered as the type. The plants have opposite undivided leaves, without stipules, tumid articulations of the stems, and seeds disposed upon a free central placenta, surrounded by several carpellary leaves. The great proportion of the species are inconspicuous weeds, like chick-weed, sandwort, &c., but many are found as favourite plants in our gardens, as the carnation, sweet-william, &c.

**Caryop'sis**, in botany, a small one-seeded, dry, indehiscent fruit in which the seed adheres to the thin pericarp throughout, as in wheat and other grains.

**Caryo'ta**, a genus of palms, with doubly-pinnate leaves, the best-known species of which (*C. urens*) is a native of most of tropical Asia; it supplies an inferior kind of sago, and from its juice is made toddy or palm-wine.

**Casale** (kâ-sâ'lâ), a city of Northern Italy, province of Alessandria, on the Po, 18 miles N.N.W. of Alessandria. Its citadel, founded in 1590, was one of the strongest in Italy, but is now dilapidated. It has a cathedral, consecrated in 1107. Silk is the chief industry. Pop. 17,096.

**Casalpusterlengo**, a town of Northern Italy, in the province of Milan; commerce in Parmesan cheese. Pop. 5513.

**Casamicciola** (kâ-sâ-mich'o-lâ), a village on the Italian island of Ischia, frequented for sea-bathing and the use of its warm springs, but recently destroyed by earthquakes.

**Casano'va**, GIOVANNI JACOPO, DE SEINGALT, born at Venice, 1725, known by his Memoirs as an adventurer who acted a prominent part in all situations, amongst all classes of society, and in all the large cities of Europe, by turns acting the part of diplomatist, preacher, abbot, lawyer, and charlatan. Among others with whom he came in contact were Rousseau, Voltaire, Suvaroff, Frederick the Great, and Catherine II. He died in Bohemia in 1798. His celebrated Memoirs are a lively picture of the manners of his times, but probably not very veracious.

**Cas'areep**. See *Cassareep*.

**Casas**, BARTOLOMEO DE LAS. See *Las Casas*.

**Casau'bon**, ISAAC DE, classical scholar, born Feb. 18, 1559, at Geneva, was educated

by his father, a clergyman. In his ninth year he spoke Latin fluently. In 1582 he became professor of the Greek language at Geneva. Henry IV. invited him to Paris and made him royal librarian. After the death of Henry IV. he followed Sir Henry Wotton, envoy extraordinary from James I., to England, where he was received with distinction, had two benefices and a pension conferred on him, and died at London, July 1, 1614. He was buried in Westminster Abbey. Casaubon was a liberal theologian, a man of extensive learning, a good translator, and an excellent critic of the ancient classics, many of which he has edited. He wrote also an excellent treatise on Greek and Roman satire.—His son, MERIC, born at Geneva 1599, likewise distinguished himself by his learning, publishing commentaries on Terence, Marcus Aurelius, &c. He died in England in 1671.

**Cas'bin** or KAZ'VIN. See *Kazvin*.

**Cascade Range**, a range of mountains in North America, near the Pacific coast, to which they are parallel, extending from the Sierra Nevada in California northwards to Alaska. It contains several active volcanoes. Highest peak, Mount St. Elias, 19,500 feet. The highest peaks in the U. States portion of it are in Washington territory, where Tacoma reaches 14,444 feet.

**Cascari'la**, the aromatic bitter bark of *Croton Eleutheria*, a small tree of the nat. order Euphorbiaceæ. (See *Croton*.) The name has recently been applied also to a subdivision of the genus *Cinchõna* (which see).

**Casco Bay**, a bay of America, in Maine, U. States, between Cape Elizabeth on w.s.w. and Cape Small Point on e.n.e. Within these capes are more than 300 small islands, most of them very productive.

**Case**, in grammar, a modification or inflection of a noun, pronoun, or adjective, by which a different shade of meaning is communicated to the word. In nouns and pronouns case supplies the place of prepositions, indicating the relation of the word thus modified to other words in the phrase or sentence, as John (nominative) speaks; John's (possessive) dog barks. There is only one case in English for nouns, the possessive or genitive (John's). English pronouns have three cases—nominative, genitive, and accusative, as *he*, *his*, *him*. In Sanskrit there are eight cases. In French, Italian, Spanish, and Portuguese the nouns have no case-inflections. In German there are four cases, nominative, genitive, dative, accusative.

**Case**, in letterpress printing. See *Printing*.

**Case**, in law, a cause or action, or a statement on which a decision is to be given.

**Case-hardening** is a process by which iron is superficially converted into steel, in such articles as require the toughness of the former conjointly with the hardness of the latter substance. The articles intended for case-hardening are first manufactured in iron, and are then placed in an iron box, with charcoal in powder, and heated to redness. Immersion into water then converts the surface into a coating of steel.

**Casein** (kā'sē-in; from L. *caseus*, cheese), that ingredient in milk which is neither coagulated spontaneously, like fibrin, nor by heat, like albumen, but by the action of acids alone, and constituting the chief part of the nitrogenized matter contained in it. Cheese made from skimmed milk and well pressed is fully half casein. Casein is one of the most important elements of animal food as found in milk and leguminous plants. It consists of carbon 53·7 per cent, hydrogen 7·15, nitrogen 15·65, oxygen 22·65, and sulphur 0·85.

**Case'mates** (from the Spanish *casa*, a house, and *matate*, to kill), in fortification, vaults which are proof against bombs, and which may serve as a place for keeping ordnance, ammunition, &c., and in case of necessity as habitations for the garrison.

**Casement**, a frame inclosing part of the glazing of a window and opening on hinges.

**Caser'ta**, or CASERTA NUOVA, the capital of the province of Caserta, South Italy, in a plain, 7 miles E.S.E. of Capua and 18 from Naples. The principal edifice is the royal palace, a large and richly-decorated structure, commenced in 1752 by Charles III. of Spain. Pop. 17,257.—The province has an area of 2307 square miles and a population, 1891, of 734,884.

**Case-shot**, in artillery, is formed by putting a quantity of small iron balls into a cylindrical tin box called a *canister*, that just fits the bore of the gun. This kind of shot is very injurious to an enemy within a short distance. The shrapnel-shell is a modern variety of case-shot.

**Cashan**, a town, Persia. See *Kashan*.

**Cash Credit**, CASH ACCOUNT, a mode of advancing funds originated by the Scotch banks, and since adopted by others. A cash credit is an account which the trader may overdraw to a certain amount as he

may require, paying cash in and taking it out according to his needs within that limit. Heritable property, two sureties, or some other form of security is usually demanded by the bank.

**Cash'el**, a town, Ireland, county Tipperary, 88 miles s.w. of Dublin; with a spacious cathedral, a handsome episcopal palace, now the deanery-house, barracks, &c., and several interesting ruins. Cashel was the seat of the ancient kings of Munster. Pop. 3961.

**Cashew'** (*Anacardium occidentāle*), a tree of the order Anacardiaceæ, common in the West Indies. Its

fruit is called the cashew-nut. The nut is small, kidney-shaped, ash-gray, and contains an acrid juice, but its noxious property is destroyed by roasting, after which it is esteemed a great delicacy. It is used to flavour Madeira wine, and is eaten cooked in various ways. The fumes it gives off when roasting are so acrid as sometimes to cause inflammation. The stalk or receptacle of the nut is large and fleshy and has an agreeable acid flavour.

**Cashgar'**. See *Kashgar*.

**Cash'mere**, or KASH'MIR, an extensive principality in the n.w. of Hindustan, subject to a ruler (the Maharajah) belonging to the Sikh race. The principality embraces not only Cashmere proper, but also Jamoo or Jummoo, Baltistan or Little Tibet, Ladakh, Gilghit, &c. The area is estimated at 80,000 square miles. It extends from about 32° to 37° N. lat., and from about 73° to 80° E. lon., and is largely a region of mountains, containing magnificent glaciers. The Kuenlun range bounds it on the north, one peak of which rises to the height of 28,265 feet. The country is watered by the Upper Indus and its tributaries, and by the Jhelum and Chenab. Cashmere proper, which forms a small portion of the whole, is a valley surrounded by gigantic mountains, the Himalaya and Hindu Kush, and traversed by the river Jhelum (formerly Hydaspes). There are ten chief passes through the mountains into this valley, varying in height



*Anacardium occidentale*.  
111, Cashew-nuts.

from about 9000 to 12,000 feet. The elevated situation of the valley, and the mountains of snow which surround it, render the climate rather cold; but the region is well watered by streams and very fertile. Forests on the slopes, fields of corn, rice crops along the sides of the rivers, rich orchards, and an abundant growth of flowers distinguish the district, but the fruits of warm climates do not ripen here. Among its minerals are iron and plumbago. Sulphur springs are common. Earthquakes frequently occur, and in 1885 one caused the loss of thousands of lives. Bears, leopards, wolves, the ibex, and chamois are among the animals. The flora has a strong affinity to that of Europe; the deodar cedar forms extensive and valuable forests. The common European fruits are grown, and attention is now being paid to the culture of the vine. The chief crops are wheat, barley, rice, and Indian corn, and two harvests are reaped in the year. The chief manufacture is that of the celebrated Cashmere shawls, but it is not so extensive as it once was, since manufactories have been established at Amritsar in the Punjab, and elsewhere. The genuine Cashmere shawls owe their superiority to the material of which they are made, which is, properly speaking, not wool, but a fine kind of down with which the animals of this region are clad during the winter season, and which in length and fineness far surpasses the merino wool. This down is obtained in great quantities from the Cashmere goat, the yak of Tibet, and the wild sheep. It is spun by women and girls, and then passes into the hands of the dyers. From the dyers the yarns are passed to the weaver, and the shawl is woven in stripes, which are afterwards very skilfully sewed together. The average time taken to manufacture a good Cashmere shawl is from sixteen to twenty weeks. The inhabitants of Cashmere are a fine race physically, tall, strong, and well-built, with regular features. There are thirteen separate dialects in use. The Maharajah is independent, but his relations with other states are subject to the authority of the government of India. The capital of the whole principality is Jamoo. Srinagar (or Cashmere) is the Maharajah's summer residence and largest town. The total revenue is estimated at £800,000, chiefly from land. The government revenue is paid in kind, and the grain claimed by the state is stored in public granaries and sold at fixed prices. The population,

1891, was 2,543,952, of whom 1,793,710 are Mohammedans and 691,800 Hindus.

**Cashmere Goat**, a variety of the common goat remarkable for its fine downy fleece, said to be found in perfection only in Tibet in the neighbourhood of Lhassa, but also found in other parts of this region, including Ladakh, now a province of Cashmere. The colder the region where the goat pastures, the heavier is its fleece. A full-grown goat yields not more than 8 ounces, the fine curled wool being close to the skin. A large shawl of the finest quality requires 5 lbs. of the wool; one of the inferior quality from 3 to 4 lbs.

**Cashmere Shawl.** See *Cashmere* and *Cashmere Goat*.

**Casimir III., THE GREAT**, King of Poland, born in 1309, ascended the throne in 1333, conquered Little Russia, Silesia, and repelled the Tartars. He protected the peasants with much energy, and out of favour for one of his mistresses who was a Jewess, conferred valuable privileges on the Jews. After his death the crown of Poland was recognized as elective.

**Casi'no** (Italian, a summer house), a name generally given to a kind of club-house or place of amusement, containing rooms for dancing, playing at billiards, &c.

**Caso'ria**, a town of Italy, 6 miles N.N.E. of Naples. Pop. 9791.

**Cas'pe**, a town, Spain, Aragon, province of Saragossa, 12 miles N.N.E. of Alcañiz, near the Ebro. Pop. 7500.

**Caspian Sea**, a large lake or inland sea between Europe and Asia, 730 miles in length from N. to S., and from 130 to 270 in breadth; area, 170,000 sq. miles; the largest isolated sheet of water on the globe. Its surface is 85 feet below that of the Sea of Azof; greatest depth about 3250 feet. Russian territory surrounds it on three sides, Persia on the fourth. It abounds in shallows, making navigation difficult. Among the rivers which flow into it are the Volga, Ural, Terek, and Kur. It has no outlet. The water is less salt than that of the ocean, of a bitter taste, and of an ochre colour, without ebb or flow. The fisheries are valuable, including those of sturgeon, sterlet, roach, bream, perch, carp, and porpoises. The only ports at all worthy the name on or near the Caspian are Astrakhan, Derbend, Baku, Krasnovodsk, and Astrabad. Steam-packets are now established on it. The Russians have also a fleet of war-ships in the Caspian. By the

Volga and canals there is water communication with the Baltic, and a canal has been proposed along the Manytch to the Sea of Azof.

**Casque.** See *Helmet*.

**Cass, LEWIS**, an American politician, born in Exeter, New Hampshire, in 1782. In 1813, having entered the army, he rose to the rank of general; in 1814–30 was governor of Michigan, was minister of war in 1831, was a candidate for the presidency several times, was long a senator, and in 1857–60 was secretary of state. He wrote the *History, Traditions, Languages, &c.*, of Indians in the United States. He died in June, 1866.

**Cassagnac** (kàs-àn-yàk), ADOLPHE BERNARD GRANIER DE, a French journalist and politician, born 1806, died 1880. He began his career at Paris as contributor of literary criticisms to the *Journal des Débats*, and soon made himself known, and latterly notorious, as editor of various papers, the *Globe*, the *Pouvoir*, the *Pays*, &c., and as being involved in many controversies and duels. He published various books, chiefly historical. Amongst the principal are: *Portraits Littéraires*, *Histoire des Causes de la Révolution Française*, *Histoire des Girondins*, *L'Empereur et la Démocratie moderne*. —His son, PAUL DE CASSAGNAC, born 1842, has had a career and a reputation not dissimilar to those of his father. Like his father he is a devoted Bonapartist.

**Cassan'der**, a king of Macedonia, born about 354 B.C. He displaced his brother Polysperchon in the regency, removed in succession the mother, the wife, and the son of Alexander the Great to make way for himself to the throne. He married Thesalonica, Alexander's half-sister, and founded the city of that name in her honour. In company with Seleucus, Ptolemy, and Lysimachus he defeated and slew Antigonus, king of Asia, whose dominions were divided amongst the conquerors. He died in 297 B.C.

**Cassan'dra**, in Greek legend, a daughter of Priam and Hecuba. She is fabled to have been endowed by Apollo with the gift of prophecy, coupled with this disadvantage, that her prophecies should never be believed. She frequently foretold the fall of Troy, and warned her countrymen in vain against the stratagem of the horse. When Troy was taken she fell, as part of his share of the booty, to Agamemnon, who, in spite of her warnings, carried her with him as his

slave to Mycenæ, where they were both murdered by Clytemnestra.

**Cassa'no**, two towns in Italy.—1. A town, province of and 32 miles N.N.E. of Cosenza, the seat of a bishopric. Has hot sulphurous springs. Pop. 7456.—2. CASSANO D'ADDA, a town 16 miles N.N.E. of Milan, where Prince Eugene was defeated in 1705 by the Duke de Vendôme, and the French, under Moreau, by Suwarow in 1799. Pop. 3500.

**Cas'sareep**, CASSIREEP, the concentrated juice of the roots of the common or bitter cassava (*Manihot utilissima*; see *Cassava*), flavoured by aromatics and deprived of its poisonous properties by boiling. It is used to give a relish to soups and other dishes, and forms the basis of the West Indian 'pepper-pot.' It is a powerful antiseptic, and is very useful in keeping meat fresh in a tropical climate.

**Cassa'tion**, a term used in the courts on the continent of Europe, signifying the annulling of any act or decision, if the forms prescribed by law have been neglected, or if anything is contained in it contrary to law. —*Court of Cassation*, one of the most important institutions of modern France, established by the first national assembly in 1790. In 1814 the number of its members was fixed at forty-nine, at which it still remains. The members are appointed for life. The sphere of this court is to decide on the competency of the other courts, and on the petitions to have their decisions reviewed or annulled. Its decisions are not only recorded in the journals of the courts, the decisions of which are reversed, but published likewise in an official bulletin. It has enjoyed from its commencement the respect and confidence of France.

**Cassa'va** (*Manihot utilissima*), a South American shrub, about 8 feet in height, with broad, shining, and somewhat hand-shaped leaves, and beautiful white and rose-coloured flowers, belonging to the natural order Euphorbiaceæ, sub-order Crotoneæ. A nutritious starch is obtained from the white soft root of the plant, and is called by the same name. It is prepared in the West Indies, tropical America, and in Africa in the following manner:—The roots are washed, stripped of their rind, and grated down to a pulp, which is put into coarse, strong canvas bags, and submitted to powerful pressure to express the juice, which is highly poisonous in its natural state. The flour that remains after pressing

is formed into cakes, and baked on a hot iron plate. In this state it forms a valuable article of food, upon which many of the inhabitants of Southern America live almost entirely. From cassava the tapioca of commerce is prepared. Another species (*M. Aipi*), the sweet cassava, has roots the juice of which is not poisonous, and which are an agreeable and nutritive food. The cassava is also called *Manioc* or *Mandioc*.



Cassava Plant (*Manihot utilissima*).

**Cas'sel**, or **KASSEL**, formerly the residence of the Elector of Hesse-Cassel, is now the chief town in the province of Hessen-Nassau, Prussia, on the Fulda, 91 miles N.N.E. of Frankfort-on-the-Main. The Old and New Town are connected by a bridge over the Fulda. There are several fine squares, in the principal of which, the Friedrichsplatz, the largest in any town in Germany, stands the palace of the ex-electoral, an indifferent structure. There is a museum and library (160,000 vols.), and a valuable picture-gallery. The city has manufactures of machinery, mathematical instruments, gold and silver wares, chemicals, knives, gloves, leather, porcelain, &c. There are many fine walks and public gardens in the vicinity; amongst the latter are the gardens of Wilhelmshöhe, in which is situated the ex-electoral's summer palace, the residence of the late Emperor Napoleon III., after his being taken prisoner at Sedan, from Sept. 5, 1870, to March 19, 1871. Pop. 1890, 72,477.

**Cas'sel** (ancient *Castellum Menapiorum*), a town, France, dep. Nord, on an isolated hill in the centre of a large and fertile plain, dating from the time of Julius Cæsar.

**Cas'sia**, a large genus of leguminous plants, inhabiting the tropical parts of the world. The species consist of trees, shrubs, or herbs; the leaves are abruptly pinnated, and usually bear glands on their stalks. The leaflets of several species constitute the well-known drug called senna. That imported from Alexandria is obtained from *C. acutifolia* and *C. obovata*. East Indian senna consists of the lance-shaped leaflets of *C. elongata*; and other species supply smaller quantities in commerce. *C. Fistula* is found

wild in India, and has been introduced into other tropical countries. Its legumes contain a quantity of thick pulp, which is a mild laxative, and enters into the composition of the confection of cassia and the confection of senna. The leaves and flowers are also purgative. The bark and roots of several of the Indian species are much used in medicine. *Cassia bark* is a common name for the bark of an entirely different plant, *Cinnamomum cassia*, belonging to the laurel family. It is much imported into Europe, mostly from China, and is also called *Cassia lignea*. Its flavour somewhat resembles that of cinnamon, and as it is cheaper it is often substituted for it, but more particularly for the preparation of what is called oil of cinnamon. The cassia of the Bible was probably cassia bark. *Cassia buds*, which are similar in flavour, are obtained from allied trees.

**Cas'sicus**, an American genus of insectivorous birds, the Cassicans, family Icteridæ (American orioles), allied to the starlings, remarkable for the ingenuity with which they weave their nests. *C. cristatus*, sometimes called the crested oriole, a S. American bird, constructs a pouch-shaped nest of the length of 30 inches.

**Cassi'ni**, a name famous in astronomy and physics for three generations:—(1) GIOVANNI DOMENICO, born in 1625 near Nice, became professor of astronomy at the University of Bologna, but afterwards settled in France. He discovered four new satellites of Saturn and the zodiacal light, proved that the axis of the moon is not perpendicular to the plane of the ecliptic, and showed the causes of her libration. He died in 1712.

—(2) JACQUES, his son, born at Paris in 1677. After several essays on subjects in natural philosophy, &c., he completed his great work on Saturn's satellites and ring. His labours to determine the figure of the earth are well known. He died in 1756.—

(3) CASSINI DE THURY, CÉSAR FRANÇOIS, son of the preceding, born in 1714, member of the Academy from his twenty-second year, undertook a geometrical survey of the whole of France, which was completed by his son. He died in 1784.—(4) CASSINI, JEAN DOMINIQUE, COUNT DE THURY, son of the preceding, born at Paris 1748, was a statesman of ability as well as a mathematician. In 1787 he completed the topographical work which was begun by his father, and which in its complete state consists of 180 sheets. He died in 1845.

**Cassi'no**, a game at cards somewhat resembling whist.

**Cassiodo'rus**, or CASSIODORIUS, MAGNUS AURELIUS, a Roman writer, born in the latter half of the 5th century A.D. He became chief minister of the Ostrogoth king Theodoric, and wrote a collection of letters, *Variarum Epistolarum Libri XII.*, which contain most valuable information with regard to the Ostrogothic rule in Italy. He wrote also a History of the Goths.

**Cassiopeia** (-pē'ya), a conspicuous constellation in the northern hemisphere, situated next to Cepheus, and often called the *Lady in her Chair*. It contains fifty-five stars, five of which, arranged in the form of a w, are of the third magnitude.

**Cassiquiari** (kā-sik-i-ä'rē), or CASSIQUIARE, a large river of South America, in Venezuela, which branches off from the Orinoco and joins the Rio Negro, a tributary of the Amazon. By means of this river water communication is established for canoes over an immense tract of South America, it being practicable to sail from the interior of Brazil to the mouth of the Orinoco.

**Cassiter'ides** (-dēz), a name derived from the Greek *kassiteros*, tin, and anciently applied to the tin district of Cornwall, or the Scilly Isles, though some identify the Cassiterides with small islands on the N.W. coast of Spain.

**Cassit'erite** (see preceding art.), an ore of tin widely distributed, and the one from which most of the metal is obtained. It is a peroxide, and consists of tin 79, oxygen 21.

**Cas'sius**, full name CAIUS CASSIUS LONGINUS, a distinguished Roman, one of the assassins of Julius Cæsar. In the civil war that broke out between Pompey and Cæsar he espoused the cause of the former, and, as commander of his naval forces, rendered him important services. After the battle of Pharsalia he was apparently reconciled with Cæsar, but later was amongst the more active of the conspirators who assassinated him B.C. 44. He then, together with Brutus, raised an army, but they were met by Octavianus and Antony at Philippi. The wing which Cassius commanded being defeated, he imagined that all was lost, and killed himself, B.C. 42. See *Brutus* and *Cæsar*.

**Cas'sius**, PURPLE OF (named from its discoverer, a German physician), a purple pigment used in porcelain and glass painting, prepared from the muriate of gold by adding to it a mixture of the protochloride and perchloride of tin.

**Cassivellau'nus**, a British chief who, when Cæsar invaded Britain, held sway over the tribes living to the N. of the Thames, and who, on account of his valour, was appointed leader of the British forces which opposed Cæsar. He had at first some slight successes, but Cæsar ultimately forced a passage across the Thames and put the enemy to flight. In the end Cassivellaunus sued for peace, which was granted on condition that he should pay a yearly tribute and give hostages.

**Cas'sock**, a tight-fitting coat worn under the gown or surplice by the clergy. The cassock is generally black; but in the Church of Rome only the ordinary priests wear black cassocks, those of bishops being purple, of cardinals scarlet, and that of the pope white.

**Cas'sowary**, a family of birds akin to the ostrich, emeu, &c., among living, the moa and others among extinct, birds. The shortness of their wings totally unfits them for



Helmeted Cassowary (*Casuarus galeatus*).

flying, and, like others of their order, the pectoral or wing muscles are comparatively slight and weak, while those of their posterior limbs are very robust and powerful. The cassowaries are divided into two genera—*Casuarus*, or cassowary proper, and *Dromaeus*, the emeu. The former has a long compressed bill, a crest on the head, and stiff featherless quills on the wings; the latter has a broader and shorter bill, feathers on the head, and no rudiment of the wing visible externally. They all have three toes. Several species of both genera are known, and of these the most familiar is the helmeted cassowary (*C. galeatus*), so called from its head being surmounted by an osseous prominence, covered with a sort of horny helmet. The cassowary feeds on fruits, eggs

of birds, &c., and bolts its food with great voracity. It is a native of the island of Ceram. The skin of the head and superior part of the neck is naked, of a deep-blue and fiery-red tint, with pendent wattles similar to those of the turkey-cock. It is about 5½ feet long. Of the other nine species one inhabits Australia and five New Guinea, the rest the adjacent islands. The Australian species is very similar to that of Ceram, and indeed they all resemble each other. They inhabit thick forests and scrub, and run with great rapidity. In self-defence they can kick with great force. See also *Emeu*.

**Cast**, in the fine arts, is an impression taken by means of wax or plaster of Paris from a statue, bust, bass-relief, or any other model, animate or inanimate. When plaster casts are to be exposed to the weather their durability is greatly increased by saturating them with linseed-oil, with which wax or rosin may be combined.

**Casta'lia**, a celebrated fountain in Greece sacred to Apollo and the Muses, and fabled to have the power of inspiring those who drank its waters. It issues from a fissure between two peaked cliffs adjoining Mount Parnassus.

**Castanea**. See *Chestnut-tree*.

**Cas'tanets**, an instrument composed of two small concave shells of ivory or hardwood, shaped like spoons, placed together, fastened to the thumb, and beat with the middle finger. This instrument is used by the Spaniards and Moors as an accompaniment to their dances and guitars.

**Caste**, a term applied to a distinct class or section of a people marked off from others by certain restrictions, and whose burdens or privileges are hereditary. The word is derived from the Portuguese *casta*, a breed or race, and was originally applied to the classes in India whose occupations, customs, privileges, and duties are hereditary. It is probable that wherever caste exists it was originally grounded on a difference of descent and mode of living, and that the separate castes were originally separate races. It now prevails principally in India, but it is known to exist or have existed in many

other regions. Some maintain that it was prevalent in ancient Egypt, but this seems uncertain. All Hindus are divided into four castes: the Brahmans or sacerdotal class, the Kshatriyas or military class, the Vaisyas or mercantile class, and the Sudras or servile class. But this fourfold division is rather a theory than according to the facts, the Hindus being actually divided into a great number of special castes, distinguished by their trades, &c. (See *Brahmanism*.) 'The effect of the caste system is,' as the Cyclopædia of India says, 'that no man may lawfully eat with any individual of any other caste, or partake of food cooked by him, or marry into another caste family; but he may be his friend, his master, his servant, his partner.' Those that are outside of any caste are known as *pariahs*.

**Castelar'**, EMILIO, a Spanish politician and author, born in 1833. In 1856 he was made professor of history in the University of Madrid, but becoming involved in the republican disturbances of 1866, he had to take refuge in Switzerland. Having gone back to Spain in 1868 he was returned to the Cortes in the following year. In 1873 he was elected president of the republican Cortes, but resigned in Jan. 1874, in consequence of the vote of confidence being defeated. After the pronunciamiento in favour of Alphonso XII., Dec. 13, 1874, Castelar retired from Spain, but in a year or two returned, and has since been a member of the Cortes. He has published many novels, poems, and political works.

**Castel-Franco**, a fortified town in North Italy, in the province and 15 miles w. of Treviso; the birthplace of the painter Giorgione. Pop. 4000.

**Castel'amare**.—1. A seaport town of Italy, on the Gulf of Naples. It is fortified, and has a royal dockyard, manufactories of linen, silk, &c. Pop. 22,207.—2. A seaport on the north coast of Sicily, 20 miles E. of Trapani. Wine, fruit, grain, oil, &c., are exported. Pop. 11,160.

**Castel'an**, or CHÂTELAIN, properly the owner or commander of a castle. In Flanders and France the title went with the possession of certain districts, and in Normandy and Burgundy châtelains ranked next after bailiffs, with both civil and military authority. In Germany the châtelains were imperial officers with military and civil jurisdiction in fortified places.

**Castella'na**, town of S. Italy, prov. Bari. Pop. 8092.

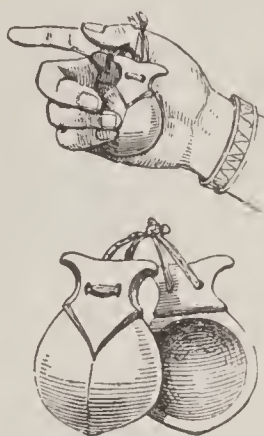

Castanets.

**Castellane'ta**, a cathedral town of Southern Italy, 18 miles n.w. Tarentum. Cotton is extensively grown in the vicinity. Pop. 7903.

**Castelleo'ne**, a town of North Italy, 12 miles n.w. of Cremona. Pop. 5700.

**Castellon-de-la-Plana** (kàs-tel-yon'), a town, Spain, capital of the province of Castellon, 40 miles n.n.e. of Valencia, in a large and fertile plain, with manufactures of sail-cloth, woollen and hempen fabrics, ropes, paper, soap, &c., and some trade in hemp, grain, and fruit. Pop. of town, 23,204; of province, 323,474; area of latter, 2445 sq. miles.

**Castelnau'dary**, a town of Southern France, dep. Aude, 22 miles w.n.w. of Carcassone, with manufactures of cloth, linen, and earthenware, distilleries and tanneries, and a good trade. Pop. 7442.

**Castel-Vetra'no**, a town, Sicily, province of Trapani, on a rocky hill; industries: silk, linen, cotton, &c. The white wine produced in the neighbourhood is esteemed the best in Sicily. Pop. 20,053.

**Casti**, GIAMBATISTA, a poet, born in 1721 at Prato, in the vicinity of Florence. His writings are of a lively and graceful but almost always licentious character. The *Novelle Galanti*, a series of tales; the *Animali Parlanti*, an epic poem; and his comic operas are amongst his chief works. He died at Paris in 1803.

**Castiglione** (kàs-tēl-yō'nā), small town of North Italy, 17 miles s.e. of Brescia, where the French obtained a decisive victory over the Austrians in 1796, which gave to Marshal Augereau his title of Duc de Castiglione. In the vicinity is Solferino. Pop. 3716. There is a larger town of the same name in Sicily, prov. Catania; pop. 8114.

**Castiglione** (kàs-tēl-yō'nā), BALDASSARE, one of the most elegant of the older Italian writers; born 1478, died 1529. Among his works the *Libro del Cortegiano* (Book of the Courtier) is the most celebrated. His letters are valuable contributions to political and literary history.

**Castile** (kas-tēl'), an ancient kingdom of Spain, the nucleus of the Spanish monarchy, extends over a large part of the peninsula from the Bay of Biscay southward. It is divided into NEW CASTILE and OLD CASTILE. The former (*Castilla la Nueva*) occupies nearly the centre of the peninsula; area, 28,010 square miles. It is traversed from e. to w. by three lofty mountain chains, nearly parallel to each other—the Sierra Guar-

rama, the mountains of Toledo and Sierra Molina, and the Sierra Morena. Between these chains, which form the great watersheds of the province, lie two extensive plains or plateaux, almost without wood, and arid and barren in appearance. Dryness, indeed, is the curse of the whole country, and there is a great deficiency of method alike in agriculture and industries. The inhabitants are of a grave, manly character, with much of the old Spanish pride and probity, but devoid of enterprise, and content to live on from day to day as their fathers did before them. This ancient province now forms the five provinces of Madrid, Ciudad-Real, Cuenca, Guadalajara, and Toledo. Pop. 1,671,739.—OLD CASTILE (*Castilla la Vieja*) stretches from the Bay of Biscay to New Castile; area, 25,405 sq. miles. It is traversed by three mountain chains—the Sierra de Guadarrama, the Sierra de Deza, and the Cantabrian Mountains. It is less dry than New Castile, and grain, particularly wheat, is raised in great abundance. The pastures both of the mountains and the plains are excellent, and much merino wool is produced. Old Castile now forms the provinces of Burgos, Logroño, Santander, Soria, Segovia, Avila, Palencia, and Valladolid. Pop. 1,730,295. See *Spain*.

**Castillejo** (kàs-til-yā'hō), CRISTO'VAL DE, a Spanish poet, born in 1494, died 1556. His works possess great originality, and his language is pure and manly, yet sparkling with wit and satire. He was the last representative of the old Spanish court poetry, and strenuously opposed Boscan and Garcilaso in introducing the classical Italian forms of literature.

**Casting**, the running of melted metal into a mould prepared for the purpose, so as to produce an article of a certain shape. Iron-casting (or iron-founding) is the most important branch. In general an exact pattern, usually of wood, is employed by the iron-founder. The floor of every foundry is composed, for several feet deep, of a loamy sand, in which deep pits may be sunk to bury large moulds. The wooden pattern is pressed firmly down into this, the sand being shovelled up all around, level with the top of the pattern, and well rammed down. The pattern is then lifted out of the sand, all small pieces of sand which may have fallen into the mould carefully blown away, and some finely-powdered charcoal sifted over the surface. The molten metal is then poured into the mould until it is full. The



whole is then covered with sand to keep the air from it while it cools. An open horizontal bed of sand is sufficient for casting many articles, but with articles of a more complex form and not too large, a frame or box, called a *flask*, is generally employed to hold together the sand used in casting, the num-

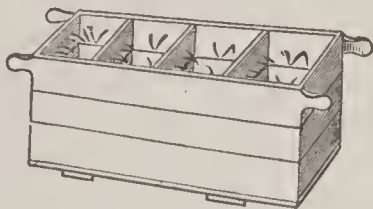

Moulding Flask.

ber of flasks varying according to the form and parts of the mould. In ordinary operations the pattern is laid on a board known as the turn-over board, and the flask placed over it, the sand being carefully rammed into the flask till it is full. Another board, known as the bottom-board, is then laid upon it. The flask is then turned over, the first or turn-over board taken off, the one side of the pattern uncovered, a fine facing of sand spread upon the surface to prevent adhesion, after which a second flask, called the *cope*, sometimes made with crossbars to strengthen it and help to hold the sand, is placed upon it and sand carefully rammed

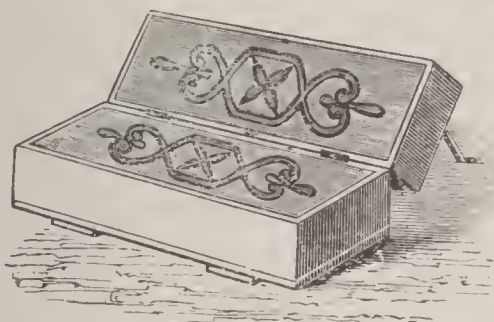

Drag and Cope opened.

in. The cope or second flask is then lifted off, the sand which it contains carrying the impression of the upper side of the pattern; the pattern in the lower part of the flask, or *drag*, is then carefully drawn out, and any injuries which the mould receives during the operation repaired. Holes or passages are then cut into the sand for pouring in the metal, all loose sand carefully removed, the cope replaced and secured to the drag by clamps. The mould is now ready for the molten metal. In pouring, the metal is generally run through two or three different passages at the same time to prevent it losing fluidity by cooling. It is only in lighter castings that sand, of the proper degree of dryness, porosity, and adhesiveness, is used. In heavy castings the mould is usually made of

loam, which is more adhesive, and in complicated articles the making of the mould is often a difficult process. Small articles of simple form and of easily-fusible alloys, such as bullets, printing types, &c., are often cast in metal moulds. Articles of sculpture are usually cast in plaster of Paris, which, when mixed with water, runs into the finest lines of a mould and takes a most exact impression. The variety of articles made by casting is very great: boilers, cisterns, cylinders, pumps, railings, grates, cannon, cooking-utensils, and many objects of decorative art.

**Casting-vote**, the vote of a presiding officer in an assembly or council which decides a question when the votes of the assembly or house are equally divided between the affirmative and negative.

**Cast-iron**, the name given to the iron obtained from the blast-furnace by running the fused metal into moulds prepared for the purpose. The moulds are in the form of long narrow channels, from which the iron, when it has cooled and solidified, is taken in bars called *pigs*, between 3 and 4 feet long and 3 or 4 inches broad. See *Iron*.

**Castle**, an edifice serving at once as a residence and as a place of defence, especially such an edifice belonging to feudal times. Castles differed somewhat at different times and in different places, but they had all several features of similarity. The first defence of a castle was usually the moat or ditch, that sometimes comprised several acres; and behind it was the outer wall, generally of great height and thickness, strengthened with towers at regular distances, and pierced with loopholes through which missiles could be discharged at the assailants. The main entrance through the outer wall was protected by the *barbican*, with its narrow archway, and strong gates and *portcullis*, and inside there were usually an outer and an inner court, and the strong more or less detached building known as the *keep*, which formed the residence of the owner and his family. This was the most strongly constructed of all the buildings, to which the defenders retreated only in the last extremity. The cut shows the castle of the Sires de Coucy, France, built in the 13th century. In the foreground is the outer bailey or esplanade, fortified, and containing a chapel, stables, and other buildings. The outer entrance to this was formed by the barbican. *a* is the fosse, 20 yards broad; *b*, the gateway, approached by two swing-bridges, defended by two guard-rooms,

and having a double portcullis within, giving entrance to vaulted guard-rooms with sleeping apartments, &c., above, *c*; *d*, inner bailey or courtyard; *e*, covered buildings for the men defending the walls or curtains; *f*, apartments for the family, entered by the

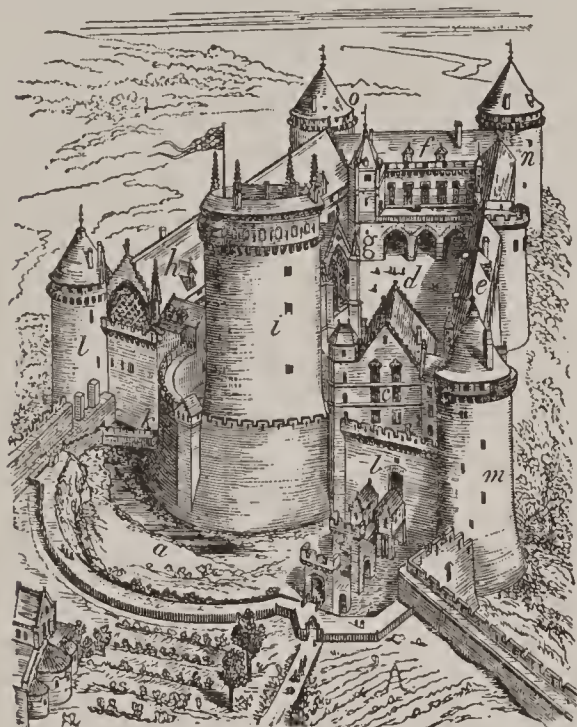

Castle—Château de Coucy.

grand staircase, *g*; *h*, great hall, with store-rooms and vaults below; *i*, donjon or keep (the chapel is seen behind it), the strongest part of the castle, with walls of immense thickness. At *k* was a postern leading from the donjon and communicating with an outer postern, drawbridge, &c.; *l*, *m*, *n*, *o*, towers or bastions flanking the walls. In English Edwardian castles (so named from Edward III.) the solid keep becomes developed into an open quadrangle, defended at the sides and angles by gatehouses and towers, and containing the hall and state apartments ranged along one side of the court. Around this inner court two or three lines of defence are disposed concentrically. Such castles frequently inclose many acres, and present an imposing appearance. The parts of a perfect Edwardian castle are—the *inner bailey* or inner court; the *walls of the enceinte*, single, double, or triple; the *middle* and *outer baileys*, contained between the walls; the *gatehouses* and *posterns*, or small doors in the wall; and the *moat* or *ditch*, which was usually filled with water. The walls were all strengthened by towers, either circular, square, oblong, or multangular, projecting both outwards and inwards. Such towers

were capable of being defended independently of the castle. The gatehouses are distinct works covering the entrance; they contain gates, one or two portcullises, and loopholes raking the passage. From the front of these gatehouses the drawbridge was lowered over the ditch. The gateways had frequently a barbican attached. This was a passage between high walls, in advance of the main gate, and having an outer gate of entrance, which was defended by towers and the parapet connected with the main gateway. The top of the wall was defended by a battlemented parapet, and frequently pierced by cruciform loopholes.

**Castlebar'**, a town, Ireland, capital of county Mayo, with some trade in grain and other agricultural produce. Pop. 3855.

**Castleford**, a town of Yorkshire, W. Riding, 10 miles s.e. of Leeds, with large glass-works. Pop. 1891, 14,143.

**Castlemaine**, a municipal town in Talbot county, Victoria, Australia, 64 miles north-west of Melbourne, pleasantly situated and well built and laid out. It owes its importance to the gold-mining and agriculture carried on in its neighbourhood. Pop. 5762.

**Castlereagh** (kas'l-rā), LORD. See *Londonderry*.

**Castletown**, a small town and seaport near the southern extremity of the Isle of Man, long the capital of the island. In the centre is Castle Rushen, originally a Danish fortress of the 10th century, latterly much extended, and now partly used as a prison and public offices. Pop. 2243.

**Cast'or**, CASTO'REUM, a reddish-brown substance, of a strong penetrating smell, secreted by two glandular sacs connected with the organs of reproduction of the beaver, and used by perfumers.

**Castor and Pollux**, in Greek mythology, twin divinities, sons of Zeus (Jupiter) and Leda, also called Dioscūri (sons of Zeus). Castor was mortal, but Pollux was immortal. The former was particularly skilled in breaking horses, the latter in boxing and wrestling. They were the patron deities of mariners. In the heavens they appear as one of the twelve constellations of the zodiac, with the name of *Gemini* (the Twins).

**Castor and Pollux** are two minerals which are found together in granite in the island of Elba. Castor is a silicate of aluminium and lithium, pollux is a silicate of aluminium and the rare element cæsium.

**Castor'idæ**, a family of rodent animals comprising the beaver, &c.

**Castor-oil**, the oil obtained from the seeds of *Ricinus communis*, or *Palma christi*, a native of India, but now distributed over all the warmer regions of the globe. The oil is obtained from the seeds by bruising



Castor-oil Plant (*Ricinus communis*)

and pressing. The oil that first comes away, called cold-drawn castor-oil, is reckoned the best; an inferior quality being obtained by heating or steaming the pressed seeds, and again subjecting them to pressure. The oil is afterwards heated to the boiling point, which coagulates and separates the albumen and impurities. Castor-oil is used medicinally as a mild but efficient purgative. It is chiefly imported from India. The plant is often cultivated as an ornamental plant.

**Castrametation**, the art of tracing out and disposing to advantage the several parts of a camp on the ground.

**Castration**, the act of depriving a male animal of the testicles. It is practised on domestic animals (as oxen and horses) with the object of rendering them more submissive and docile, &c. Men who are castrated are known as eunuchs.

**Castrén**, MATTHIAS ALEXANDER, a philologist and distinguished student of the Finnish languages, was born in 1813 in Finland. Educated at the University of Helsingfors, his attention was turned to the language of his native country. He travelled much among the nations of the Arctic regions, both in Europe and Asia, including the Norwegian and Russian Lapps, and the Samoyeds of Siberia and the coasts of the White Sea. He was appointed in 1851 professor of the Finnish and old Scandinavian languages in the University of Helsingfors, but he died next year. Among his works are a Swedish translation

of the Great Finnish epic, the Kalevala; besides grammars, travels, and other works.

**Castres** (kăstr), a town of Southern France, dep. Tarn, 46 miles east of Toulouse, on the Agout, which divides it into two parts. There are tanneries, paper-mills, foundries, &c., and manufactures of woollen goods, linen, glue, &c. Pop. 19,101.

**Cas'tries**, a town of the W. Indies, capital of the British island St. Lucia. Pop. 4555.

**Castro**, INEZ DE, a lady of noble birth, secretly married to Pedro, son of Alphonso IV., king of Portugal, after the death of his wife Constantia (1345). The old king Alphonso, fearful that this marriage would injure the interests of his grandson Ferdinand (the son of Pedro by his deceased wife), resolved to put Inez to death. Three noblemen, Diego Lopez Pacheco, Pedro Coelho, and Alvarez Gonsalvez, were his counsellors in this scheme, and carried it out themselves by stabbing Inez within the convent where she lived (1355). Two years after King Alphonso died, and Pedro, inducing the king of Castile to give up to him two of the murderers, who had taken refuge there (the third, Diego Lopez, managed to escape), put them to death with cruel tortures. The king then made public declaration of the marriage that had taken place between him and the deceased Inez; and had her corpse disinterred and placed on a throne, adorned with the diadem and royal robes, to receive the homage of the nobility. The body was then conveyed to Alcobaça and buried with great honours. The history of the unhappy Inez has furnished many poets of different nations with materials for tragedies, and her story is one of the finest episodes in the *Lusiads* of Camoens.

**Castro-del-Rio**, a town, Spain, Andalusia, in the province and 16 miles S.E. of Cordova, on the Guadajoz. There are manufactures of linen, woollen, and earthenware. Pop. 10,261.

**Castrogiovanni** (-jo-vàn'nē), a town, Sicily, province of Caltanissetta, near the centre of the island, on a high table-land more than 4000 feet above the sea-level. The site of ancient Enna, in ancient times it was adorned with the groves and temples of Ceres (Demeter). Sulphur is obtained in the district. Pop. 14,084.

**Castrovil'lari**, a town of S. Italy, prov. Cosenza. Pop. 10,505.

**Cast-steel**, steel made by fusing the materials and running the product into moulds. See *Steel*.

**Castuera** (kás t̄-ā'rá), a town, Spain, province of and 67 miles E. by S. Badajoz. Pop. 6869.

**Casuari'na**, or BOTANY-BAY OAK, the single genus of the natural order of Casuarinaceæ, or cassowary-trees. There are about thirty species, natives chiefly of Australia. They are jointed leafless trees or shrubs, nearly related to the birches, having their male flowers in whorled catkins and their fruits in indurated cones. Some of them produce timber called *Beefwood* from its colour. *C. quadrivalvis* is called the she-oak, *C. equisetifolia* the swamp-oak.

**Cas'uistry**, that part of the old theology and morals which relates to the principles by which difficult cases of conscience (especially where there is a collision of different duties) are to be settled. Hence a casuist is a moralist who endeavours to solve such doubtful questions. There have been many celebrated casuists among the Jesuits—for example, Escobar, Sanchez, Busembaum, &c.—famous for their ingenuity and the fine-spun sophistry of their solutions.

**Casus belli**, the material grounds which justify a declaration of war.

**Cat** (*Felis domesticus*), a well-known domesticated quadruped, order Carnivora, the same name being also given to allied forms of the same order. It is believed that the cat was originally domesticated in Egypt, and the gloved cat (*F. maniculāta*) of Egypt and Nubia has by some been considered the original stock of the domestic cat, though more probably it was the Egyptian cat (*F. caligāta*). It was seldom, if at all, kept by the Greeks and Romans, and till long after the Christian era was rare in many parts of Europe. Some have thought that the domestic breed owed its origin to the wild cat; but there are considerable differences between them, the latter being larger, and having a shorter and thicker tail, which also does not taper. The domestic cat belongs to a genus—that which contains the lion and tiger—better armed for the destruction of animal life than any other quadrupeds. The short and powerful jaws, trenchant teeth, cunning disposition, combined with nocturnal habits (for which their eyesight is naturally adapted) and much patience in pursuit, give these animals great advantages over their prey. The cat in a degree partakes of all the attributes of her race. Its food in a state of domestication is necessarily very various, but always of flesh or fish if it can be obtained. Instances of its

catching the latter are known, though usually the cat is extremely averse to wetting itself. It is a very cleanly animal, avoiding to step in any sort of filth, and preserving its fur in a very neat condition. Its fur is very easily injured by water on account of the want of oil in it, and it can be rendered highly electric by friction. The cat goes with young for sixty-three days, and brings forth usually from three to six at a litter, which remain blind for nine days. It is usually regarded as less intelligent than the dog, but this is by no means certain. It has a singular power of finding its way home when taken to a distance and covered up by the way. Among the various breeds or races of cat may be mentioned the tailless cat of the Isle of Man (and the Crimea); the tortoise-shell, with its colour a mixture of black, white, and brownish or fawn colour; the large Angora or Persian cat, with its long silky fur; and the blue or Carthusian, with long soft grayish-blue fur.—The wild cat (*Felis catus*) is still found in Scotland and in various other parts of Europe and Western Asia, chiefly in forest regions, making its lair in hollow trees or clefts of rocks. It is a very fierce animal. There are a number of other animals of similar size and habits known as cats, such as the fishing-cat (*F. viverrina*) of Bengal and Eastern Asia, the leopard cat (*F. bengalensis*) of Northern India and South-eastern Asia, the marbled cat (*F. marmorāta*) of the same region, the rusty-spotted cat (*F. robiginōsa*), a small Indian species, &c. The ocelot, serval, and margay may also be called cats.

**Catachresis** (-krē-sis), a figure in rhetoric, when a word is too far wrested from its true signification; as, to speak of tones being made more *palatable* for 'agreeable to the ear.' So in Scripture we read of the *blood* of the grape. Also, in philol. the employment of a word under a false form through misapprehension in regard to its origin; thus *crayfish* or *crawfish* (Fr. *écrevisse*) has its form by *catachresis*.

**Cat'aclysm**, in geol. a physical catastrophe of great extent, supposed to have occurred at different periods, and to have been the efficient cause of various phenomena observed in the surface configuration of localities.

**Cat'acombs** (Gr. *kata*, down, and *kumbos*, a hollow or recess), caves or subterranean places for the burial of the dead, the bodies being placed in graves or recesses hollowed

## CATACOMBS.

out in the sides of the cave. Caves of this kind were common amongst the Phœnicians, Greeks, Persians, and many oriental nations. In Sicily and Asia Minor numerous excavations have been discovered containing sepulchres, and the catacombs near Naples are remarkably extensive. Those of Rome, however, are the most important. The term



Catacomb of St. Agnes, Rome.

*catacumbæ* is said to have been originally applied to the district near Rome which contains the chapel of St. Sebastian, in the vaults of which, according to tradition, the body of St. Peter was first deposited; but (besides its general application) it is now applied in a special way to all the extensive subterranean burial-places in the neighbourhood of Rome, which extend underneath the town itself as well as the neighbouring country, and are said to contain not less than 6,000,000 tombs. They consist of long narrow galleries usually about 8 feet high and 5 feet wide, which branch off in all directions, forming a perfect maze of corridors. Different stories of galleries lie one below the other. Vertical shafts run up to the outer air, thus introducing light and air, though in small quantity. The graves or *loculi* lie longwise in the galleries. They are closed laterally by a slab, on which there is occasionally a brief inscription or a symbol, such as a dove, an anchor, or a palm-branch, and sometimes both. The earliest that can be dated with any certainty belongs to the year 111 A.D. It is now regarded as certain that in times of persecution the early Christians frequently took

refuge in the catacombs, in order to celebrate there in secret the ceremonies of their religion; but it is not less certain that the catacombs served also as ordinary places of burial to the early Christians, and were for the most part excavated by the Christians themselves. In early times rich Christians constructed underground burying-places for themselves and their brethren, which they held as private property under the protection of the law. But in course of time, partly by their coming under the control of the church and partly by accidents of proprietorship, these private burying-grounds were connected with each other, and became the property, not of particular individuals, but of the Christian community. In the 3d century A.D. there were already several such common burying-places belonging to the Christian congregations, and their number went on increasing till the time of Constantine, when the catacombs ceased to be used as burying-places. From the time of Constantine down to the 8th century they were used only as places of devotion and worship. But their use as formal places of worship can only have been occasional, for the limited dimensions even of the largest rooms, and the extreme narrowness of the passages, must have made it impossible for any large number to take efficient part in the services at one time. But though the idea of the catacombs as regular places of worship may be carried too far, there is no doubt, from the episcopal chairs, altars, basins, &c., found within them, and from the subjects of the mosaics and carvings on the walls, that the rites of the church, and particularly the eucharist and the sacrament of baptism, were often celebrated there. They could never have served as dwelling-places for any length of time to the Christians, residence in most of them for more than a short time being very dangerous to the health. During the siege of Rome by the Lombards in the 8th century the catacombs were in part destroyed, and soon became entirely inaccessible, so that they were forgotten, and only the careful and laborious investigations of moderns, amongst whom De Rossi (*Roma Sottterranea*) and Parker (*The Catacombs*) may be mentioned, have thrown anything like a complete light on the origin and history of the catacombs. There are extensive catacombs at Paris, consisting of old quarries from which has been obtained much of the material for the building of the city. In them are accumulated

bones removed from cemeteries now built over.

**Cat'acoustics**, the science of reflected sounds, or that part of acoustics which considers the properties of echoes.

**Catafal'cc**, CATAFALQUE, a temporary and ornamental structure, representing a tomb placed over the coffin of a distinguished person or over a grave.

**Cat'alan**, a native of Catalonia, or North-eastern Spain, or the language of Catalonia, which holds a position similar to the Provençal, having been early cultivated and boasting a considerable literature. It was established as a literary language by the close of the 13th century, and is still to some extent used as such in its own region.

**Catalan Grand Company**, the name given to a troop of adventurers raised by Roger di Flor about the beginning of the 14th century. They numbered about 8000 men of different nationalities, Catalans, Sicilians, Arragonese, &c., and were led by Roger to the East to aid Emperor Andronicus in his struggle with the Turks. They fought well and did good service, but their habits of plunder and rapine made them as formidable to their friends as their foes. The company was broken up in 1315, some twelve years after its formation.

**Catala'ni**, ANGELICA, one of the most celebrated of Italian female singers, was born in 1779, and died in 1849. Family misfortunes compelled her to turn her remarkable voice to account, and in her 16th year she made her first appearance on the stage at Venice. After filling the chief soprano parts in the best opera-houses of Italy she visited successively Madrid, Paris, and London, enjoying everywhere great professional triumphs, as she continued to do in similar tours which she repeatedly made afterwards. In 1830 she retired.

**Catalaunian Plain**, the wide plain around Châlons-sur-Marne, famous as the field where Aëtius, the Roman general, and Theodoric, king of the West Goths, gained a complete victory over Attila, 451 A.D.

**Catalep'sy**, a spasmodic disease, generally connected with hysteria, in which there is a sudden suspension of the senses and volition, with statue-like fixedness of the body and limbs in the attitude immediately preceding the attack, while the action of the heart and lungs continues, and the pulse and temperature remain natural. It is generally the consequence of some other disease, or

of a constitution enfeebled by the gradual operation of unobserved causes.

**Catalo'nia** (anc. *Hispania Tarraconensis*), an old province of Spain, bounded N. by France, E. and S.E. by the Mediterranean, S. by Valencia, and W. by Arragon. The country in general is mountainous, but intersected with fertile valleys, while the mountains themselves are covered with valuable woods and fruit-trees, the slopes being cut in terraces and plentifully supplied with water by an artificial system of irrigation. Wheat, wine, oil, flax, hemp, vegetables, and almost every kind of fruit are abundant. There are mines of lead, iron, alum, &c. On the coast is a coral-fishery. Catalonia, though less fertile than most of Spain, stands pre-eminent for the industry of its inhabitants, who speak the Catalan dialect (see *Catalan*). Pop. 1,800,428; area, 12,480 sq. miles. It comprises the modern provinces of Tarragona, Gerona, Lerida, and Barcelona.

**Catal'pa**, a genus of plants, order Bignoniaceæ. The species are trees with simple leaves and large, gay, trumpet-shaped flowers. *C. syringifolia*, a North American species, is well adapted for large shrubberies, and has been introduced into England and other parts of Europe. *C. longissima* contains much tannin in its bark, and is known in the West Indies by the name of French oak.

**Catal'ysis**, or CONTACT ACTION, the chemical change which occurs when one body decomposes another without being itself changed; thus oxide of cobalt decomposes a solution of bleaching-powder into chloride of calcium and oxygen, itself remaining without change.

**Catamaran'**, a sort of raft used in the East Indies, Brazil, and elsewhere. Those of the island of Ceylon, like those of Madras and other parts of that coast, are formed of three logs lashed together. Their length is from 20 to 25 feet, and breadth  $2\frac{1}{2}$  to  $3\frac{1}{2}$  feet. The centre log is much the largest, and is pointed at the fore-end. These floats are navigated with great skill by one or two men in a kneeling posture. They think nothing of passing through the surf which lashes the beach at Madras when boats of the best construction would be swamped.

**Catamar'ca**, a province of the Argentine Republic, South America; area, about 31,500 square miles; mountainous in all directions except the S. Pop. 130,000. The capital is Catamarca, or more fully San Fernando de Catamarca. Pop. about 6000.

**Catame'nia.** See *Menstruation*.

**Cat'amount,** or CATAMOUNTAIN, the wild cat. In America the name is also given to the tiger or the puma.

**Cata'nia** (anc. *Catāna*), a city on the east coast of Sicily, in the province of Catania, at the foot of Mount Etna. It has been repeatedly visited by tremendous earthquakes, one of the worst of which was in 1693, when 18,000 people were destroyed, and has been partially laid in ruins by lava

from eruptions of Mount Etna. But Catania has always revived, and has much more the features of a metropolis than Palermo. Most of the edifices have an air of magnificence unknown in other parts of the island, and the town has a title to rank among the elegant cities of Europe. The cathedral, founded by Count Roger in 1094, is a fine building. The manufacture of silk, linen, and articles in lava, amber, &c., constitutes the chief industry. The ruins of



The Square of the Elephant, Catania.

the amphitheatre, which was more extensive than the Colosseum at Rome, are still to be seen, as also the remains of the theatre, baths, aqueducts, sepulchral chambers, hippodrome, and several temples. The harbour was choked up by the eruption of 1669, so that for larger vessels there is nothing but a roadstead. In spite of this Catania has a considerable trade, and exports wheat, barley, wine, oil, &c. Pop. 96,017.

**Catanza'ro,** a cathedral city, South Italy, capital of province of the same name, on a height, 5 miles from the Gulf of Squillace, with manufactures of silk and velvet, and some trade in wheat, wine, oil, &c. Pop. 20,931. Area of prov. 2307 sq. miles; pop. 1891, 457,660.

**Cataplasm.** See *Poultice*.

**Cat'apult,** a machine of the ancients for projecting missiles, chiefly arrows. They may be described as a kind of gigantic cross-bows. *Balista* were engines somewhat

similarly constructed, but were chiefly confined to the shooting of stones.

**Cat'aract,** a disease of the eye, consisting in an opacity of the crystalline lens, or its capsule, or both. It is quite different from amaurosis, which is a disease of the retina. In cataract the lens becomes opaque, and is no longer capable of transmitting the light. Its earliest approach is marked by a loss of the natural colour of the pupil, and when developed it causes the pupil to have a milk-white or pearly colour. It is most common in old or elderly people, and is quite painless. Cataract is treated by different surgical operations, all of them consisting in removing the diseased lens from its situation opposite the transparent cornea. In *couching*, the lens is depressed, removed downwards, and kept from rising by the vitreous humour; but this method is now almost entirely given up in favour of removal of the lens by extraction. *Extrac-*

tion consists in making an incision in the cornea, and in the capsule of the lens, by which the lens may be brought forward, and through the cut in the cornea, so as to be altogether removed. The third operation is by *absorption*. This consists in wounding the capsule, breaking down the crystalline, and bringing the fragments into the anterior chamber of the eye, where they are exposed to the action of the aqueous humour, and are at length absorbed and disappear. Extraction is now the regular method, and after it is effected a special kind of spectacles are required.

**Cat'aract**, or WATERFALL, the leap of a stream over a ledge or precipice occurring in its course. Many cataracts are remarkable for their sublimity, the grandest being the Falls of Niagara, on the Niagara River between Lakes Erie and Ontario, in North America, the river having here a fall of about 160 feet. Amongst other notable falls are those of the river Montmorency, a tributary of the St. Lawrence, which are 242 feet in height; that of the river Potaro, in British Guiana, about 822 feet high and 369 broad; that of the Yosemite river, California, which makes a perpendicular leap of 2100 feet; the Victoria Falls, on the river Zambesi, in South Africa, about 370 feet high and 1860 yards broad. The cataract of the Riukanfoss, on the river Maan, in Norway, is about 900 feet high. The cascade of Gavarnie, in the Pyrenees, is reputed the loftiest in Europe, being about 13,000 feet, but its volume is so small that it is converted into spray before reaching the bottom. The fall of the Staubbach at Lauterbrunnen, in Switzerland, is between 800 and 900 feet, but has also a very small volume of water; the falls of the Rhine at Schaffhausen, renowned over Europe, are 300 feet broad and nearly 100 feet in height. In Italy the falls of Terni, on the Velino, and those of the Anio, at Tivoli, are artificial but very beautiful. Among British waterfalls, the falls of the Clyde, three in number, viz. Bonniton Linn, 30 feet, Corra Linn, 84 feet, and Stonebyres Linn, 80 feet, are remarkable for their beauty and grandeur. The falls of the river Foyers on the east side of Loch Ness are also very remarkable. See the separate articles.

**Catarrh** (ka-tar'; from Gr. *katarreō*, I flow down), an increased secretion of mucus from the membranes of the nose, fauces, and bronchi, accompanied with fever and attended with sneezing, cough, thirst, lassitude,

and want of appetite. There are two species of catarrh, one which is very common, and is called a *cold in the head*; and another, the influenza, or epidemic catarrh. It is seldom fatal except in scrofulous habits by laying the foundation of consumption.

**Cataw'ba**, a river, United States, in North Carolina, giving its name to a light wine of rich Muscadine flavour, which has acquired some celebrity in America, the grape from which it is made having been first discovered near its sources. The wine is chiefly made at Cincinnati, and has had the honour of being sung by Longfellow in one of his lyrics.

**Cat-bird** (*Turdus felivox* or *Galeoscoptes carolinensis*), a well-known species of American thrush, which during the summer is found throughout the Middle and New England States, frequenting thickets and shrubberies. Its note is strikingly similar to the plaint of a kitten in distress. The plumage is a deep slate-colour above and lighter below, and it is about 9 inches in length. In habit it is lively, familiar, and unsuspecting; the song is largely imitative of those of other birds. During the winter it inhabits the extreme south of the United States, and is found also in Mexico and Central America. The cat-bird frequently attacks the common black snake, which, in the absence of the bird, rifles its nest.

**Catch**, a short piece of music, frequently of a humorous and bacchanalian character written generally in three or four parts. It is a sort of short canon, the second voice taking up the theme when the first has completed the first phrase, the third following the second in same manner.

**Catchfly**, a popular name of several plants of the genus *Silēnē* (which see). *Dionca muscipula* and *Lychnis Viscaria* are also so called.

**Câteau-Cambresis** (kă-tō-kān-brā-sis), a town, France, dep. Nord, on the right bank of the Selle, famous for the treaty of its name signed here in 1559, by which Henri II. of France gave up Calais to the English, and agreed to a mutual exchange with Spain of all conquered territories. It has various textile manufactures. Pop. 9657.

**Catechet'ical Schools**, institutions for the education of Christian teachers, of which there were many in the Eastern Church from the 2d to the 5th century. The first and most renowned were those formed at Alexandria (A.D. 160-400) on the model of



the famous schools of Grecian learning in that place, Pantænus, Clement, and Origen being their most famous teachers. The schools at Antioch were also in high repute from about 290 till the 5th century. The Arian controversy broke up the Alexandrian, and the Nestorian and Eutychian controversies the Antioch schools. They were succeeded at a later date by the cathedral and monastic schools.

**Catechism** (kat'e-kizm; from Greek *katēcheō*, to sound down, utter, instruct orally), an elementary book containing a summary of principles in any science or art, but particularly in religion, reduced to the form of questions and answers. The first regular catechisms appear to have been compiled in the 8th and 9th centuries, those by Kero of St. Gall and Otfried of Weissenburg being most famous. In the R. Catholic Church each bishop has the right to make a catechism for his diocese. But in modern times R. Catholic catechisms are generally a pretty close copy of the one drawn up by the Council of Trent (published 1566), of which an English translation was issued in London (1687) under the patronage of James II. Among Protestants the catechisms of Luther (1518, 1520, and 1529) acquired great celebrity, and continue to be used in Germany, though not exclusively. Calvin's smaller and larger catechisms (1536-39) never gained the popularity of those of Luther. The catechism of the Church of England in the first book of Edward VI., March 7, 1549, contained merely the baptismal vow, the creed, the ten commandments, and the Lord's prayer, with explanations, the part relative to the sacraments being subjoined at the revision of the liturgy during the reign of James I. The catechism of the Church of Scotland is that agreed upon by the Assembly of Divines at Westminster, with the assistance of commissioners from the Church of Scotland, and approved of by the General Assembly in the year 1648. What is called the Shorter Catechism is merely an abridgment of the Larger, and is the one in most common use. The best-known catechism among English Protestant Dissenters was that of Dr. Watts; but the use of catechisms is far from usual amongst them.

**Cat'echu** (-shö), a name common to several astringent extracts prepared from the wood, bark, and fruits of various plants, especially by decoction and evaporation from the wood of *Acacia Catechu*, as well as

from the seeds of the palm *Arēca Catechu*, and from the *Uncaria Gambier*. Catechu is one of the best astringents in the materia medica. It consists chiefly of tannin, and is used in tanning, in calico-printing, &c. It is chiefly obtained from Burmah. Called also *Terra Japonica* and *Cutch*.

• **Catechumens** (-kū'menz; literally, persons receiving instruction), a name originally applied to those converted Jews and heathens in the first ages of the church who were to receive baptism and had a particular place in the church, but were not permitted to share the sacrament. Afterwards it was applied to young Christians who, for the first time, wished to partake of this ordinance, and for this purpose went through a preparatory course of instruction.

**Cat'egory**, or **PREDICAMENT**, in logic, an assemblage of all the beings contained under any genus or kind ranged in order. The ancients, following Aristotle, held that all beings or objects of thought may be referred to ten categories, viz. *quantity, quality, relation, action, passion, time, place, situation, and habit*. Plato admits only five: *substance, identity, diversity, motion, and rest*; the Stoics four: *subjects, qualities, independent circumstances, relative circumstances*. Descartes suggested seven divisions: *spirit, matter, quantity, substance, figure, motion, and rest*. Others make but two categories, *substance and attribute, or subject and accident*; or three, accident being divided into the *inherent and circumstantial*. In the philosophy of Kant the term categories is applied to the primitive conceptions originating in the understanding independently of all experience (hence called pure conceptions), though incapable of being realized in thought except in their application to experience. These he divides into four classes, quantity, quality, relation, and modality, placing under the first class the conceptions of unity, plurality, and totality; under the second, reality, negation, and limitation; under the third, inherence and subsistence, causality and dependence, and community (mutual action); and under the fourth, possibility and impossibility, existence and non-existence, necessity and contingency. J. S. Mill applies the term categories to the most general heads under which everything that may be asserted of any subject may be arranged. Of these he makes five, existence, co-existence, sequence, causation, and resemblance, or, considering causation as a peculiar case of sequence, four.

**Cat'enary Curve**, that curve which is formed by a cord or chain of uniform density and thickness when allowed to hang freely between two points. It is of interest as bearing on the theory of arches and domes, and as the curve assumed by the chains of a suspension-bridge.

**Caterpillar.** See *Butterfly*.

**Cat-fish**, a remarkably voracious fish, the *Anarrhichas lupus*, belonging to the family of gobies, known also as the *Wolf-fish*; also the name common to several North American fish of the genus *Pimelodus*. *P. catus* (the common cat-fish) is known also as the *Horned Pout* and *Bull-head*. It is excellent eating.

**Cat'gut**, a cord made from the intestines of sheep, and sometimes from those of the horse, ass, and mule, but not from those of cats. The manufacture is chiefly carried on in Italy and France by a tedious process. Catgut for stringed instruments, as violins and harps, is made principally in Milan and Naples, the latter having a high reputation for treble strings.

**Catha**, a genus of plants, nat. order Celastraceæ, mostly natives of Africa. The leaves and twigs of *C. edulis*, known as *khat* or *cafta*, possess properties akin to those of tea and coffee, and the plant is much cultivated by the Arabs. The use of khat is of greater antiquity than that of coffee.

**Cath'ari** (Greek, *kathāros*, pure), a name akin to 'Puritans,' applied at different times to various sects of Christians. It became a common appellation of several sects which first appeared in the 11th century in Lombardy and afterwards in other countries of the West, and which were violently persecuted for their alleged Manichean tenets and usages. They had many other local names. Thus from their relation to the Bulgarian Paulicians they were sometimes termed *Bulgarians*. In Southern France, when they were mostly prosperous, they were confounded with the Albigenses, and were exterminated with them. The Cathari proper were dualists, of a type closely related to the older Gnostics, held a community of goods, abstained from war, marriage, and the killing of animals, and rejected water-baptism. They professed to strive after a higher life than that embodied in the ordinary religious ideals.

**Catharine I.**, Empress of Russia and wife of Peter the Great, was a woman of humble origin, who, having become mistress to Prince Menschikoff, was relinquished by

him to the czar. In 1708 and 1709 she bore the emperor the Princesses Anna and Elizabeth, the first of whom became the Duchess of Holstein by marriage, and mother of Peter III. The second became Empress of Russia. In 1711 the emperor publicly acknowledged Catharine as his wife, and she was subsequently proclaimed empress, and crowned in Moscow in 1724. When Peter with his army seemed irreparably lost on the Pruth in 1711 Catharine secured the relief of her husband by bribing the Turkish general. At Peter's death in 1725 Catharine was proclaimed Empress and autocrat of all the Russias, and the oath of allegiance to her was taken anew. Catharine died suddenly in 1727, her death having been hastened by dissipation.

**Catharine II.**, Empress of Russia, was born in 1729, her father being Christian Augustus, prince of Anhalt-Zerbst. In 1745



Catharine II. of Russia.

she was married to Peter, nephew and successor of the Russian Empress Elizabeth, on whose death in 1762 her husband succeeded as Peter III. In danger of being supplanted by his mistress, the Countess Woronzoff, Catharine, with the assistance of her lover, Gregory Orloff, and others, won over the guards and was proclaimed monarch (July, 1762). Peter attempted no resistance, abdicated almost immediately, and was strangled in prison a few days later, apparently without Catharine's knowledge. By bribes and threats she readily secured her position, and at once entered upon the administration with great and far-seeing

activity. On the death of Augustus III. of Poland she caused her old lover, Poniatowski, to be placed on the throne with a view to the extension of her influence in Poland, by which she profited in the partition of that country in the successive dismemberments of 1772, 1793, and 1795. By the war with the Turks, which occupied a considerable part of her reign, she conquered the Crimea and opened the Black Sea to the Russian navy. Her dream, however, of driving the Turks from Europe and restoring the Byzantine Empire was not to be fulfilled. Her relations with Poland and with other European powers induced her to make peace with Turkey in 1792, and accept the Dniester as the boundary line between the two countries. She appears to have been successful in improving the administration of justice, ameliorated the condition of the serfs, constructed canals, founded the Russian Academy, and in a variety of ways contributed to the enlightenment and prosperity of the country. Her enthusiasm for reform, however, was summarily checked by the events of the French revolution; and the dissipation and extravagance of her court were such that there was even a danger of its exhausting the empire. Of her many lovers Potemkin was longest in favour, retaining his influence from 1775 till his death in 1791, directing Russian politics throughout that period in all essential matters. She died in 1796.

**Catharine, St.**, in the Roman hagiology there are six saints of this name, of whom only two are of importance:—(1) St. Catharine, a virgin of Alexandria who suffered martyrdom in the 4th century. She is represented with a wheel; and the legend of her marriage with Christ has been painted by several of the first masters. (2) St. Catharine of Siena, born in 1347, who was preternaturally pious from her birth, and at six years of age was given to self-castigation and other penances. Urban VI. and Gregory XI. sought her advice, and in 1460—80 years after her death—she was canonized. Her poems and letters have been published.

**Catharine, St., ORDERS OF.** The knights of St. Catharine on Mount Sinai are an ancient military order, instituted for the protection of the pilgrims who came to visit the tomb of St. Catharine on this mountain. In Russia the order of St. Catharine is a distinction for ladies, instituted by Catharine, wife of Peter the Great, in memory of his signal escape from the Turks in 1711.

**Catharine de' Medici** (dā-med'i-chē), wife of Henry II., king of France, born at Florence in 1519, the only daughter of Lorenzo de' Medici, duke of Urbino, and the niece of Pope Clement VII. She was married to the Duke of Orleans, afterwards Henry II., in 1533, but had little or no influence at the French court either during the reign of her husband, who was under the influence of his mistress Diana de Poitiers, or during the reign of her eldest son, Francis II., who, in consequence of his marriage with Mary Stuart, was devoted to the party of the Guises. The death of Francis placed the reins of government, during the minority of her son Charles IX., in her hands. Wavering between the Guises on one side, who had put themselves at the head of the Catholics, and Condé and Coligny on the other, who had become very powerful by the aid of the Protestants, she played off one faction against the other in the hope of increasing her own power; and the thirty years of civil war which followed were mainly due to her. Her influence with Charles IX. was throughout of the worst kind, and the massacre of St. Bartholomew's Day was largely her work. After the death of Charles IX., in 1574, her third son succeeded as Henry III., and her mischievous influence continued. She died in 1589, shortly before the assassination of Henry III. Of her two daughters, Elizabeth married Philip II. of Spain, and Margaret of Valois married Henry of Navarre, afterwards Henry IV.

**Catharine Howard**, Queen of England, fifth wife of Henry VIII., daughter of Lord Edmund Howard, son of the Duke of Norfolk; born 1522. Her beauty and vivacity induced the king to marry her in 1540, but her conduct appears to have been of a dubious kind both before and after marriage, and she was charged in 1541 with adultery. Her paramours Derham and Culpepper were beheaded, and two months later (Feb. 1542) she shared the same fate.

**Catharine of Aragon**, Queen of England, the youngest daughter of Ferdinand of Aragon and Isabella of Castile, was born in 1485. In 1501 she was married to Arthur, prince of Wales, son of Henry VII. Her husband dying about five months after, the king, unwilling to return her dowry, caused her to be contracted to his remaining son, Henry, and a dispensation was procured from the pope for that purpose. On his accession to the throne as Henry VIII. in 1509 she was crowned with him, and despite

the inequality of their ages retained her ascendancy with the king for nearly twenty years. Her children, however, all died in infancy, excepting Mary, and on the advent of Anne Boleyn, Henry affected to doubt the legality of his union with Catharine. He applied therefore to Rome for a divorce, but the attitude of the papal court ultimately provoked him to throw off his submission to it, and declare himself head of the English church. In 1532 he married Anne Boleyn; upon which Catharine, no longer considered queen of England, retired to Ampthill in Bedfordshire. Cranmer, now raised to the primacy, pronounced the sentence of divorce, notwithstanding which, Catharine still persisted in maintaining her claims, showing from first to last a firm and dignified spirit. She died in January 1536.

**Catharine of Braganza**, wife of Charles II., king of England, and daughter of John IV., king of Portugal, was born in 1638. In 1662 she married Charles II., but her husband's infidelities and neglect, and her childlessness, were a source of mortification to her. In 1693 she returned to Portugal, where, in 1704, she was made regent, and in the conduct of affairs during the war with Spain showed marked ability. She died in 1705.

**Catharine Parr**, sixth and last wife of Henry VIII. of England, was born in 1512, and had had two husbands before she became Henry's queen in 1543. Her attachment to the reformed religion brought her into some danger, but from this she was released by the king's death in 1547. After the death of the king she espoused the Lord-admiral Lord Thomas Seymour, uncle to Edward VI.; but the union was an unhappy one, and she died in childbed in 1548. She was the author of a volume of Prayers or Meditations, and a tract and letters published posthumously.

**Cathar'tes.** See *Turkey-buzzard*.

**Cathar'tics**, a general name for purgative medicines.

**Cathay'**, an old name of China.

**Cath'cart**, SIR GEORGE, son of the following, born in 1794; entered the Life Guards in 1810, accompanied his father as *attaché* to Russia, and subsequently acted as aide-de-camp to the Duke of Wellington at Waterloo. He served in Nova Scotia and the West Indies, quelled the rebellion in Canada in 1837, and was appointed in 1852 governor at the Cape of Good Hope, where he showed ability in subduing the Kaffir insurrection.

On the outbreak of the Crimean war great things were expected of him, but he fell as divisional commander at Inkerman in 1854.

**Cathcart**, WILLIAM SHAW, EARL OF, British general, son of Baron Cathcart of Cathcart, Renfrew, born in 1755, died in 1843. He served in the American war and against the French Republic in Flanders and Germany, and in 1807 commanded the land forces in the expedition against Copenhagen, being then created viscount. In 1812 he went to Russia as minister-plenipotentiary, and in 1814 was created an earl. Subsequently he was for several years ambassador to the Russian court. His son, CHARLES MURRAY, EARL OF CATHCART, born in 1783, served under Wellington in the Peninsula and at Waterloo, was in 1830 created a major-general, and in 1851 commander-in-chief in Canada; died in 1859.

**Cathe'dral**, the principal church of a diocese, so called from its possessing the episcopal chair or *cathedra*. This is really what distinguishes a cathedral from other churches, though most cathedrals are also larger and more elaborate structures than ordinary churches, and have various dignitaries and functionaries connected with them. The cathedral establishments in England regularly consist of a dean and chapter, presided over by the bishop, the chapter being composed of a certain number of canons. The dean and chapter meet in the chapter-house of the cathedral; in them the property of the cathedral is vested, and they nominally elect the bishop on a *congé d'élire* from the crown. There are often a certain number of honorary canons, also 'minor canons' who assist in the performance of the choral services, choristers, &c. As regards architecture cathedrals naturally vary much. Those in England are almost all in the Gothic style, cruciform or cross-shaped in arrangement, and having connected with them a chapter-house, side chapels (varying in number and position), cloisters, crypt, &c. This style and arrangement are also common on the continent of Europe, and in most modern cathedrals; but the Romanesque, Renaissance, and Byzantine styles of architecture are also employed. Many cathedrals furnish the most magnificent examples of the architecture of the middle ages; and as they were intended to accommodate great numbers of people, and to exhibit imposing religious services, they are often of great size (St. Peter's, Rome, is 613 feet long and 450 across the transepts).

## CATHEDRAL — CATHOLIC CHURCH.

Among the most notable cathedrals are St. Peter's, the largest of all, founded 1450; the cathedral at Milan, founded in 1386, built of white marble; the cathedral at Florence, begun about 1294, one of the finest specimens of the Italian-Gothic style; Cologne Cathedral, commenced in 1248 (and only

finished recently); Notre Dame, at Paris, begun 1163; and those of Amiens, Chartres, and Rheims. The most noteworthy English cathedrals are St. Paul's, London (1675-1711), in the Renaissance style, and those of Canterbury, Ely, Exeter, Lichfield, Lincoln, Norwich, Salisbury, Wells, Westmin-

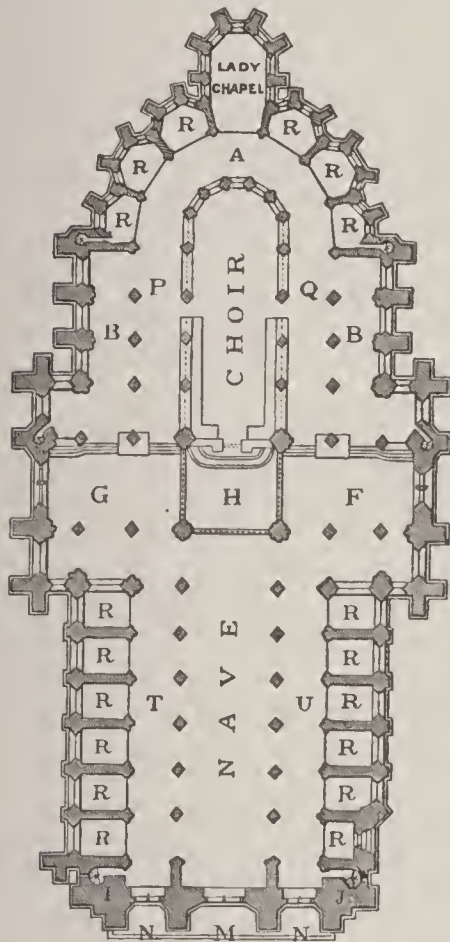

Plan of Amiens Cathedral.

A, Apsidal aisle. B B, Outer aisles of choir.  
 F G, Transepts. H, Central tower.  
 I J, Western turrets.  
 M, Principal or western doorway.  
 N N, Western side doors.  
 P Q, North and south aisles of choir.  
 R R R, Chapels.  
 T U, North and south aisles of nave.

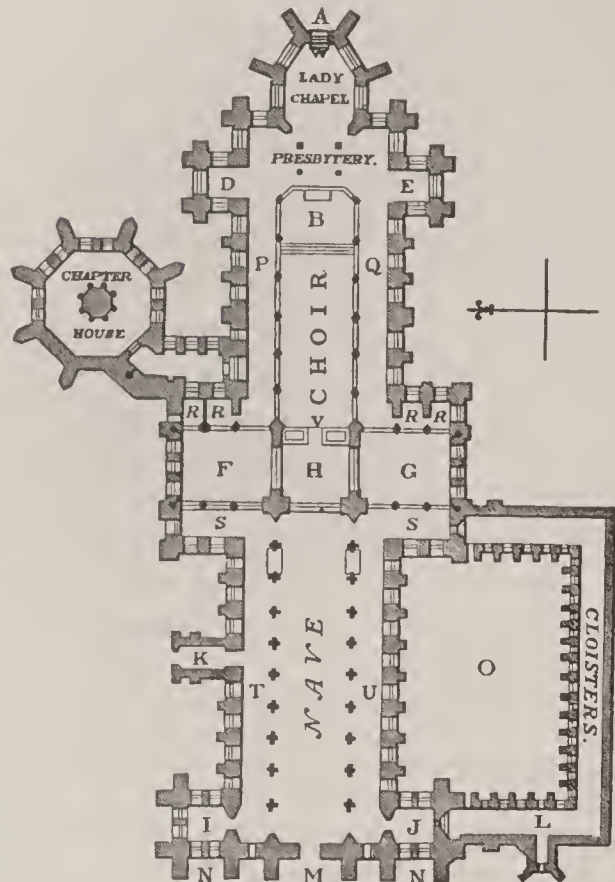

Plan of Wells Cathedral.

A, Ape or apsis. B, Altar, altar-platform, and altar-steps. D E, Eastern or lesser transept. F G, Western or greater transept. H, Central tower. I J, Western towers. K, North Porch. L, Library or register. M, Principal or western doorway. N N, Western side doors. O, Cloister yard or garth. P Q, North and south aisles of choir. R S, East and west aisles of transept. T U, North and south aisles of nave. R R, Chapels. V, Rood screen or organ loft. W, Altar of Lady chapel.

ster, and York. The cathedrals of Glasgow and Kirkwall are the only entire cathedrals in Scotland, exclusive of modern edifices.

**Catherine.** See *Catharine*.

**Cath'eter**, a term applied in surgery to a tube, usually of silver or india-rubber, which is introduced into the bladder through the urethra, for the purpose of drawing off the urine when it cannot be discharged in the natural way.

**Cathetom'eter**, an instrument for measuring small differences of level between two points; in its simplest form, a vertical graduated rod, upon which slides a hori-

zontal telescope. With the telescope the observer sights the two objects under examination, and the distance on the graduated rod moved over by the telescope is the measure of the distance of height between the two objects.

**Cathode.** See *Anode*; also *X-Rays*.

**Cath'olic Apostolic Church.** See *Irvingites*.

**Catholic Church**, the universal church, the whole body of true believers in Christ; but the term is often used as equivalent to the Roman or Western Church. See *Roman Catholic Church*.

**Catholic Emancipation**, *i.e.* the abolition of those civil and ecclesiastical restraints to which the R. Catholics of Great Britain, and particularly of Ireland, were once subjected. By the statutes of William III. Roman Catholics were forbidden to hold property in land, and their spiritual instructors were open to the penalties of felony; and although latterly these restrictions had not been enforced, they remained unrepealed in England until 1778. The proposal to repeal similar enactments on the Scotch statute-books was delayed by the strenuous opposition of the Protestant associations, in connection with which the Lord Gordon riots occurred. In 1791, however, a bill was passed allowing Roman Catholics who took the oath of allegiance to hold landed property, enter the legal profession, and enjoy freedom of education. In Ireland the Roman Catholics had been even more unjustly treated. Their public worship was proscribed, all offices and the learned professions were closed against them, they were deprived of the guardianship of their children, and if they had landed estates they were forbidden to marry Protestants. Burke and a strong body of followers took up their cause, and in 1792 and 1793 the worst of the disabilities were removed by the Irish parliament. Restraints on worship, education, and disposition of property were removed; they were admitted to the franchise, and to some of the higher civil and military offices, and to the honours and endowments of the Dublin University. They continued to be excluded, however, from thirty public offices, and from parliament—an arrangement which could not be changed without a repeal of the Corporation and Test Acts. It was part of Pitt's scheme when the union with Ireland was formulated in 1799 to admit Irish Roman Catholics to the parliament of the United Kingdom and to offices of state. To this proposal, however, George III. was strongly hostile, and in 1801 Pitt was compelled to resign. Between that year and 1828 numerous attempts were made to abolish remaining disabilities, but without success, the Lords throwing out the bills passed latterly in the Commons, and George IV. proving not less unyielding than his father. At length, in 1829 (April 10), an emancipation bill was carried through the Commons by Mr. Peel, and through the Lords by the Duke of Wellington. By this act Catholics are eligible to all offices of state, excepting the lord-

chancellorships of England and Ireland, the lord-lieutenancy of Ireland, the office of regent or guardian of the United Kingdom, and that of High Commissioner to the Church of Scotland. They are still excluded from the right of presentation to livings, and all places connected with the ecclesiastical courts and establishment. The church patronage attached to any office in the hands of a Catholic is vested in the Archbishop of Canterbury. Attached to the bill is a clause for the gradual suppression of the Jesuits and monastic orders (religious establishments of females excepted).

**Catholic Epistles**, a name given to seven epistles of the New Testament—one of James, two of Peter, three of John, and one of Jude—because written to Christians in general, and not to the believers in some particular place.

**Catholic Majesty**, a title which Pope Alexander VI. gave to the kings of Spain, in memory of the complete expulsion of the Moors from Spain in 1491 by Ferdinand of Aragon. But even before that time, and especially after the council at Toledo in 589, several Spanish kings are said to have borne this title.

**Cathol'icos**, the title of the primate of the Armenian Church. His residence is at Etchmiadzin.

**Cat'iline** (LUCIUS SERGIUS CATILĪNA), a Roman conspirator, of patrician rank, born about 108 B.C. In his youth he attached himself to the party of Sulla, but his physical strength, passionate nature, and unscrupulous daring soon gained him an independent reputation. Despite the charges of having killed his brother-in-law and murdered his wife and son, he was elected prætor in B.C. 68, and governor of Africa in 67. In B.C. 66 he returned to Rome to contest the consulship, but was disqualified by an impeachment for maladministration in his province. Urged on by his necessities as well as his ambition, he entered into a conspiracy with other disaffected nobles. The plot, however, was revealed to Cicero, and measures were at once taken to defeat it. Thwarted by Cicero at every turn, and driven from the senate by the orator's bold denunciations, Catiline fled, and put himself at the head of a large but ill-armed following. The news of the suppression of the conspiracy and execution of the ring-leaders at Rome diminished his forces, and he led the rest towards Gaul. Metellus Celer threw himself between the rebels and

their goal, while Antonius pressed upon their rear, and, driven to bay, Catiline turned upon the pursuing army and perished fighting (62 B.C.).

**Catinat** (kâ-ti-nâ), NICHOLAS, Marshal of France, born at Paris 1637. He attracted the notice of Louis XIV. at the storming of Lille (1667), and by his conduct, especially at the battle of Senef, gained the friendship of Condé. He was sent as lieutenant-general against the Duke of Savoy, gained the battles of Staffardo (1690), and Marsaglia (1693), occupied Savoy and part of Piedmont, and was made marshal in 1693. In Flanders he displayed the same activity, and took Ath in 1697. In 1701 he received the command of the army of Italy against Prince Eugene; but his ill-furnished forces were defeated at Carpi, and he was disgraced. He died in 1712.

**Cat Island**, one of the Bahama Islands, about 46 miles in length from N. to S., and 3 to 7 in its mean breadth. Pop. 3000. It was long thought that it, and not Watling Island, was the Guanahani, or San Salvador, where Columbus first touched the New World in 1492.

**Catkin.** See *Amentum*.

**Catlin**, GEORGE, a writer on the American Indians, born in Pennsylvania 1796, died 1872. After practising as a lawyer for two years he set up at New York as a portrait-painter, and in 1832 commenced special studies of Indian types, residing many years amongst them both in N. and S. America. In 1840 he came to Europe, and subsequently introduced three parties of American Indians to European courts. His finely-illustrated works are: *Manners, Customs, and Condition of the N. American Indians* (1841); *North American Portfolio* (1844); *Eight Years' Travel in Europe* (1848); *Last Rambles amongst the Indians, &c.* (1868).

**Catmandoo.** See *Khatmandu*.

**Catmint**, or CATNIP (*Nepëta Cataria*), a plant of the natural order Labiatae, not uncommon in England, scarce in Scotland and Ireland, and widely diffused throughout Europe, N. America, &c. It grows erect to a height of 2 or 3 feet, has whorls of rose-tinted, whitish flowers, and stalked, downy, heart-shaped leaves. It has much the same fascination for cats as valerian root.

**Cato**, DIONYSIUS, the reputed author of the small collection of moral apophthegms known as *Catonis Disticha de Moribus ad Filium*. Nothing is known of him; but the work, which is apparently in large part a

genuine classic, had a high reputation in the middle ages.

**Cato**, MARCUS PORCIUS, the Censor, surnamed *Priscus*, also *Sapiens* and *Major* (the Wise and the Elder), a celebrated Roman, born 234 B.C. at Tusculum. He inherited from his father, a plebeian, a small estate in the territory of the Sabines, which he cultivated with his own hands. He served his first campaign, at the age of seventeen, under Fabius Maximus, was present at the siege of Capua in 214 B.C.; and five years after fought under the same commander at the siege of Tarentum. After the war was ended he returned to his farm, but by the advice of Valerius Flaccus removed to Rome, where his forensic abilities had free scope. He rose rapidly, accompanied Scipio to Sicily as quæstor in B.C. 204, became an ædile in 199, and in 198 was chosen prætor, and appointed to the province of Sardinia. Three years later he gained the consulship, and in 194 for his brilliant campaign in Spain obtained the honour of a triumph. In 191 he served as military tribune against Antiochus, and then, having abundantly proved his soldierly qualities, returned to Rome. For some years he exercised a practical censorship, scrutinizing the characters of candidates for office, and denouncing false claims, peculations, &c. His election to the censorship in 184 set an official seal to his efforts, the unsparing severity of which has made his name proverbial. From that year until his death, in 149, he held no public office, though zealously continuing his unofficial labours for the state. His hostility to Carthage, the destruction of which he advocated in every speech made by him in the forum, was the most striking feature of his closing years. His incessant "Delenda est Carthago" (Carthage must be destroyed) did much to further the third Punic war. Of his works his *De Re Rustica* (On Rural Economy) alone survives, though there exist in quotation fragments of his history and speeches.

**Cato**, MARCUS PORCIUS (called *Cato of Utica*, the place of his death, to distinguish him from the Censor, his great-grandfather), a distinguished Roman, born 95 B.C. He formed an intimacy with the Stoic Antipater of Tyre, and ever remained true to the principles of the Stoic philosophy. He distinguished himself as a volunteer in the war against Spartacus, served as military tribune in Macedonia in B.C. 67, was made quæstor in B.C. 65. His rigorous reforms won him

general respect, and in B.C. 63 he was chosen tribune of the people. During the troubles with Catiline Cato gave Cicero important aid both by his eloquence and sagacity, and at the same time set himself to thwart the ambitious projects of Pompey, Cæsar, and Crassus. Such success as he had, however, was only temporary, and he failed to prevent the formation of the triumvirate. To get rid of him they sent him to take possession of Cyprus, but, having successfully accomplished his mission, he returned, opposed the Tribonian law for conferring extraordinary powers on the triumvirs, and in 54 B.C. enforced, as prætor, an obnoxious law against bribery. On the breach between Pompey and Cæsar he threw in his lot with Pompey, and guarded the stores at Dyrrhachium, while Pompey pushed on to Pharsalia. After receiving news of Pompey's defeat he sailed to Cyrene and effected a junction with Metellus Scipio at Utica, in B.C. 47. He took command of that city, but its defence appearing hopeless after the defeat of Scipio at Thapsus, he determined on suicide, and after spending some time in the perusal of the Phædo of Plato, stabbed himself with his sword. His wounds were bound up by his attendants, but he tore off the bandages and died, B.C. 46.

**Catop'trics** (from Greek *katoptron*, a mirror), that branch of optics which explains the properties of incident and reflected light, and particularly that which is reflected from mirrors or polished surfaces. The whole doctrine of catoptrics rests on the principle that the angle of incidence is equal to the angle of reflection and in the same plane.

**Cats**, JACOB, born in 1577, one of the fathers of the Dutch language and poetry. He studied at Leyden, Orleans, and Paris, and settled at Middleburg, where he produced his Emblems of Fancy and Love, Galatea, The Mirror of Past and Present, &c. In 1627 and 1631 he was ambassador to England, where he was knighted by Charles I., and from 1636 to 1652 he was grand-pensioner of Holland. He represents the best side of the prosaic Flemish genius of the period, and his many works had a wide and prolonged popularity.

**Cat's-eye**, a mineral, a variety of quartz, very hard and semi-transparent, and from certain points exhibiting a yellow opalescent radiation or *chatoyant* appearance, somewhat resembling a cat's eye.

**Catskill Mountains**, a fine range of mountains in New York state. They lie

on the w. side of and nearly parallel to the Hudson, from which their base is, at the nearest point, 8 miles distant. The two most elevated peaks are Round Top and High Peak; the former 3804 feet, the latter 3718 feet high.

**Cat's-tail**, a plant. See *Reed-mace*.

**Cat's-tail-grass**. See *Timothy Grass*.

**Catsup**. See *Ketchup*.

**Cat'taro**, a fortified seaport of Austria, in Dalmatia, at the bottom of the Gulf of Cattaro, on the E. side of the Adriatic. The cathedral and the castle are its chief buildings. Pop. 5088.

**Cat'tegat**, a large gulf of the North Sea, between Denmark on the w., Sweden on the E., and the Danish islands of Zealand, Funen, &c., on the s.; about 150 miles from N. to S., greatest breadth about 90. It is noted for its herring-fishery, but is difficult of navigation. It contains the islands Samsøe, Anholt, Lessøe, and Hertzholm.

**Cat'termole**, GEORGE, an artist, born 1800 in Norfolk, died in 1868. He was employed as a draughtsman on Britton's English Cathedrals when only sixteen, and drew the designs for various annuals, and for his brother's History of the Civil Wars. In the earlier part of his career he painted chiefly in water-colours, but after 1857 devoted himself to oil-painting. Among the best known of his pictures are Hamilton of Bothwellhaugh about to Shoot the Regent Murray, Luther at the Diet of Spires, The Armourer's Tale, &c.

**Catti**, or CHATTI, one of the most renowned of the ancient German tribes. They inhabited what is now Hesse, also part of Franconia and Westphalia.

**Cattle**, a term applied collectively to the larger domestic quadrupeds, and often exclusively to those of the ox genus. See *Ox*.

**Cattle-plague**. See *Rinderpest*.

**Catty**, in China and the Malayan Archipelago, a weight of  $1\frac{1}{3}$  lbs.

**Catul'lus**, CAIUS (OR QUINTUS) VALERIUS, a famous Roman lyric poet, born probably B.C. 94, at Verona, or, according to some, at Sirmium, on a peninsula of Lake Benacus; died probably about B.C. 54. He was the friend of Cicero, of Plancus, Cinna, and Cornelius Nepos; to the last he dedicated the collection of his poems. Almost all the known details of his life are derived by inference from his works, and relate to such matters as his passion for Lesbia, his journey to Bithynia, and voyage home in his yacht, his pleasant villa on Lake Benacus,



&c. He was the first of the Romans who successfully caught the Greek lyric spirit, and gave to Roman literature its most genuine songs.

**Cauca** (kou'kà), a S. American river in Colombia, an important tributary of the Magdalena; length, 600–700 miles. It gives its name to a department or state of Colombia; area, 52,000 sq. miles; pop. 450,000.

**Caucasian Race**, a term introduced into ethnology by Blumenbach, in whose classification of mankind it was applied to one of the five great races into which all the different nations of the world were divided. Blumenbach believed this to be the original race from which the others were derived, and he gave it the epithet of Caucasian because he believed that its most typical form—which was also that of man in his highest physical perfection—was to be met with among the mountaineers of the Caucasus. In later classifications this 'race' is usually divided into *Aryan* or *Indo-European*, and *Semitic*. Most of the tribes inhabiting the Caucasus belong to the *Turanian* class.

**Cau'casus**, a chain of mountains which gives name to a lieutenancy under Russian government lying to the south-east of Russia Proper, between the Black Sea and the Caspian. The total area of the lieutenancy (including the district of Armenia, acquired in 1878) is 179,527 sq. miles, and the pop. about 5,500,000. The Caucasus chain of mountains traverses the lieutenancy from north-west to south-east through a length of 700 miles. It does not form a single chain, but is divided, at least for part of its length, into two, three, or even four chains, which sometimes run parallel to one another, and sometimes meet and form mountain ganglions. The heights of the chief summits are Elbruz, 18,572 feet; Kosh-tan-tau, 17,123; Dych-tau, 16,928; Kasbek, 16,546. Those mountains, as they lie north of the Caucasian watershed, are to be looked upon as European. The chief rivers are the Terek and Kur, flowing into the Caspian, and the Kuban and Rion (ancient *Phasis*) into the Black Sea. The northern part of the country produces little but grass; but the slopes and valleys on the south, and especially those nearest the Black Sea, produce various kinds of fruits, grain of every description, rice, cotton, hemp, &c. The minerals are valuable. At Baku on the Caspian immense quantities of petroleum are obtained. The inhabitants consist of small tribes of various origin and language

—Georgians, Abassians, Lesghians, Ossetes, Circassians, Tartars, Armenians, &c. Some of them are Greek and Armenian Christians, others are Mohammedans, Jews, &c. The Caucasian tribes, especially the Circassians, attracted much attention for over half a century by their stubborn resistance to the arms of Russia. This resistance came to an end in 1859 by the capture of Schamyl, their most distinguished leader.

**Cau'cus**, a term, originally American, for a private meeting of citizens to agree upon candidates to be proposed for election to offices or to concert measures for supporting a party. In Britain the term is applied to the system of political organization of which the Birmingham Liberal Association is a type, where all electioneering business is managed by a representative committee of voters. Its origin is referred to a fray between some British soldiers and Boston rope-makers in 1770, which resulted in democratic meetings of rope-makers and *caulkers*, called by the Tories (or Loyalists) *caucus* meetings.

**Caudebec** (kōd-bek), a picturesque little French town, dep. Seine-Inférieure, on the Seine, with a fine Gothic church. Pop. 2000.

**Caudebec-les-Elbeuf** (kōd-bek-lā-zel-beuf), a manufacturing town of France, dep. of Seine-Inférieure, 12 m. s. of Rouen. Pop. 11,038.

**Cau'dex**, in botany, the stem of a tree, more especially the scaly trunk of palms and tree-ferns. It often appears as a rhizome running along the surface of the earth or underground.

**Caudine Forks**, a pass of S. Italy, in the form of two lofty fork-shaped defiles, in the Apennines (now called the valley of Arpaia), into which a Roman army was enticed by the Samnites, B.C. 321, and being hemmed in was forced to surrender.

**Caul**, a popular name for a membrane investing the viscera, such as the peritoneum or part of it, or the pericardium; also a portion of the amnion or membrane enveloping the fetus, sometimes encompassing the head of a child when born. This caul was supposed to predict great prosperity to the person born with it, and to be an infallible preservative against drowning, as well as to convey the gift of eloquence. During the last century seamen often gave from £10 to £30 for a caul.

**Cau'liflower**, a garden variety of cabbage, in which cultivation has caused the inflor-

escence to assume when young the form of a compact fleshy head, which is highly esteemed as a table vegetable. Broccoli is much the same.

**Caulking** (kāk'ing), of a ship, driving a quantity of oakum into the seams of the planks in the ship's decks or sides in order to prevent the entrance of water. After the oakum is driven very hard into these seams it is covered with hot melted pitch to keep the water from rotting it.

**Caulop'teris**, a genus of fossil tree-ferns found in the coal-measures.

**Cause**, that which produces an effect; that from which anything proceeds and without which it would not exist. In the system of Aristotle the word rendered by cause and its equivalents in modern language has a more extensive signification. He divides causes into four kinds: efficient, formal, material, and final. The efficient or first cause is the force or agency by which a result is produced; the formal, the means or instrument by which it is produced; the material, the substance from which it is produced; the final, the purpose or end for which it is produced. In a general sense the term is used for the reason or motive that urges, moves, or impels the mind to act or decide.

**Caustic** (Greek *kaustikos*, burning, from *kaiō*, I burn), a name given to substances which have the property of burning, corroding, or disintegrating animal matter; or of combining with the principles of organized substances and destroying their texture.—*Lunar Caustic*, a name given to nitrate of silver when cast into sticks for the use of surgeons, &c.—*Caustic potash*, the hydrate of potassium.—*Caustic soda*, protoxide of sodium.

**Caustic**, in optics, the name given to the curve to which the rays of light, reflected or refracted by another curve, are tangents. Caustics are consequently of two kinds—*catacaustics* and *diacaustics*—the former being caustics by reflection and the latter caustics by refraction.

**Cauterets** (kōt-rā), a celebrated bathing locality in France, dep. Hautes-Pyrénées.

**Cau'tery**, in surgery, the searing or burning of living flesh by a hot iron (*actual cautery*) or a caustic substance (*potential cautery*).

**Caution**, a legal term signifying much the same as guarantee or security, now mostly used in Scots law.

**Cau'very**. See *Cavery*.

**Ca'va**, a town, South Italy, 3 miles N.W. of Salerno, with manufactures of silk, cotton, and linen. About 1 mile from Cava is a magnificent Benedictine convent. Pop. 6397.

**Cavaignac** (kā-van-yāk), LOUIS EUGÈNE, French general, born 1802, died 1857. His father, Jean Baptiste Cavaignac, was a furious revolutionist and member of the Council of Five Hundred. Young Cavaignac in 1824 joined the 2d Regiment of Engineers, and being at Arras on the outbreak of the revolution of 1830 he was the first officer in his regiment to declare for the new order of things. In 1832 he was sent to Africa, where he remained for several years, and greatly distinguished himself. When the revolution of 1848 broke out Cavaignac was appointed governor-general of Algeria; but on being elected a member of the Constituent Assembly he returned to Paris and was appointed minister of war. At the outbreak of the June insurrection Cavaignac was appointed dictator with unlimited powers. For three days Paris presented a dreadful scene of tumult and bloodshed. About 15,000 persons perished, and property was destroyed to the value of upwards of £200,000. By the energy of Cavaignac, aided by the loyalty of the army and the National Guard, the insurrection was suppressed, and France saved from a threatened dissolution of all the bonds of society. Towards the close of the year he became a candidate for the presidency of the republic, but was defeated, and Louis Napoleon was preferred to the office. On 20th December he resigned his dictatorship. After the *coup d'état* of 2d December, 1851, he was arrested and conveyed to the fortress of Ham, but was liberated after about a month's detention. In 1852 and in 1857 he was elected member for Paris of the legislative body, but on both occasions was incapacitated from taking his seat by refusing to take the oath of allegiance to the emperor.

**Cavaillon** (kā-vā-yōī), a town of Southern France, dep. Vaucluse, 14 miles S.E. Avignon, an important railway junction. Pop. 5164.

**Cavalcan'ti**, GUIDO, a Florentine philosopher and poet, born in the early part of the 13th century, died 1300. He was the friend of Dante, and, like him, a zealous Ghibelline. His Canzone d'Amore have gained him the most fame.

**Cavalier** (ka-va-lēr'), a horseman, especially an armed horseman; applied in history to the partisans of Charles I., as op-

posed to Roundheads, the adherents to the parliament.

**Cavalier**, in fortification, a work commonly situated within the bastion, but sometimes placed in the gorges or on the middle of the curtain. It is 10 or 12 feet higher than the rest of the works, and is used to command all the adjacent works and the surrounding country.

**Cavalier** (kā-vā-lyā), JEAN, leader of the Camisards in the war of the Cevennes, son of a peasant, born in 1679 near Anduze (department of Gard), died at Chelsea 1740. He was engaged in agricultural labours at Geneva when the cruel persecutions of the Protestants of the Cevennes by Louis XIV. induced him to return home. He became their leader, and, led by him, they forced Marshal Villars to make a treaty with them. Cavalier then accepted a commission in the king's service, but, fearing treachery, he retired to England, and took service under the Earl of Peterborough and Sir Cloudsley Shovel in Spain. He commanded a regiment of refugee Camisards, and distinguished himself greatly at the battle of Almanza, in New Castile, in 1707, where he was severely wounded. He was afterwards appointed governor of Jersey.

**Cav'alry**, a body of troops which serve on horseback, one of the three great classes of troops, and a formidable power in the hands of a leader who knows how to employ it with effect. Its adaptation to speedy movements is a great advantage, which enables a commander to avail himself immediately of a decisive moment, when the enemy exposes a weak point, or when disorder appears in his ranks. It is a very important instrument in completing the defeat of an enemy, in disconcerting him by a sudden attack, or overthrowing him by a powerful shock. It is very serviceable in protecting the wings and centre of an army, for escorts, for blockading, for intercepting the supplies of the enemy, for procuring intelligence, for covering a retreat, for foraging, &c. In the British army the cavalry consists of two regiments of life-guards, one of horse-guards, seven of dragoon-guards, and twenty-one other regiments, of which three are dragoons, thirteen hussars, and five lancers. These are classified also into *light* and *heavy cavalry*, with reference to the character of their armament and the size of the men and horses. A complete regiment of British cavalry is divided into four squadrons, and each of these into two troops, a troop con-

sisting of sixty-eight men; and to each troop is assigned a captain, a lieutenant, and a second lieutenant. Cavalry are usually armed with straight swords or sabres, pistols, and carabines. The total of the ten regiments of cavalry in the United States regular army is 5966; including 407 commissioned officers.

**Cav'an**, an inland Irish county in Ulster; area, 477,399 acres, of which three-fourths are arable. The north-western part is hilly; the remaining surface, which is undulating and irregular, is pervaded by bog and interspersed with many lakes; the soil is generally poor. Oats, flax, and potatoes are the chief crops. The principal towns are Cavan, Cootehill, and Belturbet. The county returns two members to parliament. Pop. 111,679.—CAVAN, the county town, 57 miles N.W. Dublin, has a courthouse, endowed school founded by Charles I., a Roman Catholic college, &c., and a considerable trade in farm produce. Pop. 3050.

**Cavati'na**, in music, a melody of simpler character than the *aria*, and without a second part and a *da capo* or return part. The term is occasionally applied, however, to short simple airs of any kind.

**Cave**, or CAVERN, an opening of some size in the solid crust of the earth beneath the surface. Caves are principally met with in limestone rocks, sometimes in sandstone and in volcanic rocks. Some of them have a very grand or picturesque appearance, such as Fingal's Cave in Staffa; others, such as the Mammoth Cave of Kentucky, which incloses an extent of about 40 miles of subterranean windings, are celebrated for their great size and subterranean waters; others for their gorgeous stalactites and stalagmites; others are of interest to the geologist and archæologist from the occurrence in them of osseous remains of animals no longer found in the same region, perhaps altogether extinct, or for the evidence their clay floors and rudely-sculptured walls, and the prehistoric implements and human bones found in them, offer of the presence of early man. Caves in which the bones of extinct animals are found owe their origin, for the most part, to the action of rain-water on limestone rocks. The deposit contained in them usually consists of clay, sand, and gravel combined. In this are embedded the animal remains, and stones either angular or rounded. Some of the remains found in European caverns belong to animals now found only in the tropical or subtropical

regions, and others are the remains of animals now living in more northerly areas; others, again, are the relics of extinct animals. Among the latter class of animals are the cave bear and lion, the mammoth and mastodon, species of rhinoceros, &c. Of others that have only migrated may be mentioned the reindeer, which is no longer found in Southern Europe; and the *Hyæna crocuta*, found in the Gibraltar caves, which now lives in South Africa. The ibex, the chamois, and a species of ground squirrel, are shown to have once lived in the Dordogne, but are now found only on the heights of the Alps and Pyrenees. Thus it is evident that the geographical conditions of the country must have been very different from what they are now. Man's relation to these extinct animals, and his existence at the time these changes took place, are demonstrated by such discoveries as those of human bones and worked flints beneath layers of hyæna droppings, as in Wokey's Hole, near Wells, England; mixed up indiscriminately, as in Kent's Hole, near Torquay, with bones of elephant, rhinoceros, hyæna, &c.; and by the fact that many bones of the extinct animals are split up, evidently for the sake of the marrow. In the Dordogne and Savigné caves fragments of horn have been found bearing carved, or rather deeply scratched, outline figures of ibex, reindeer, and mammoth. Among the most remarkable bone-caves are those of Kirkdale, in Yorkshire; Kent's Hole, Wokey's Hole; of Franconia, in Bavaria; the banks of the Meuse, near Liége; and the south of France. See *Cave-men*.

**Cave**, EDWARD, an English printer, the founder of the *Gentleman's Magazine* was born 1691, died 1754. The first number of the *Gentleman's Magazine*, which, under a considerably modified form, has continued till this day, was published in Jan. 1731. Cave is also remembered as the first to give literary work to Samuel Johnson.

**Ca'veat** (L., 'let him beware'), in law, a process in a court to stop proceedings, as to prevent the enrolment of a decree in chancery in order to gain time to present a petition of appeal to the lord-chancellor. In the United States this name is given to a notice lodged in the patent-office by a person who wishes to patent an invention, but desires to be protected till he has perfected it. It stands good for a year.

**Cave-men**, prehistoric races who lived in such European caves as those mentioned

in article *Cave*. That they were at a low state of civilization, though possessed of some artistic faculty, is evidenced by the fact that they were ignorant of the metals, of pottery, and of agriculture, and had no domestic animals. Their chief food seems to have been the reindeer, and their manner of life was probably somewhat similar to that of the Esquimaux.

**Cav'endish**, tobacco which has been softened and pressed into quadrangular cakes, so called from Thomas Cavendish, the Elizabethan circumnavigator.

**Cav'endish**, HENRY, English physicist and chemist, born at Nice in 1731; died in London 1810; the son of Lord Charles Cavendish, and grandson of the second Duke of Devonshire. He devoted himself exclusively to science, and greatly contributed to the progress of chemistry, having discovered the peculiar properties of hydrogen, the composition of water, &c. He also wrote on electricity, and determined the mean density of the earth. He lived in great retirement, and though very wealthy his habits were extremely simple. His writings consist of treatises in the *Philosophical Transactions*.

**Cavendish**, or **CANDISH**, THOMAS, an English circumnavigator in the reign of



Thomas Cavendish.

Elizabeth; born about 1555, died 1592. Having collected three small vessels for the purpose of making a predatory voyage to the Spanish colonies, he sailed from Plymouth in 1586, took and destroyed many vessels, ravaged the coasts of Chili, Peru,

and New Spain, and returned by the Cape of Good Hope, having circumnavigated the globe in two years and forty-nine days, the shortest period in which it had then been effected. In 1591 he set sail on a similar expedition, during which he died.

**Cavendish**, WILLIAM, Duke of Newcastle, was born in 1592, died 1676. Son of Sir Charles Cavendish, he was made Earl of Newcastle by Charles I. On the approach of hostilities between the crown and parliament he embraced the royal cause, and was invested with a commission constituting him general of all his majesty's forces raised north of the Trent, with very ample powers. Through great exertions and the expenditure of large sums from his private fortune he levied a considerable army, with which, for some time, he maintained the king's cause in the north. When the royal cause became hopeless he retired to Holland. He returned after an absence of eighteen years, and was rewarded for his services and sufferings with the dignity of duke. He was the author of several mediocre poems and plays, and a treatise on horsemanship.

**Cavendish**, WILLIAM, first Duke of Devonshire, distinguished statesman and patriot, was born 1640, died 1707. On various occasions he distinguished himself by his spirit and valour, and in 1677 began that opposition to the arbitrary measures of the ministers of Charles II. which caused him to be regarded as one of the most determined friends of the liberties of his country. He took an active part in promoting the Revolution, and was one of the first who declared for the Prince of Orange. His services were rewarded with the dignity of duke.

**Cavendish College**, Cambridge, founded by the Duke of Devonshire in 1876 for the purpose of giving cheap university education to youths younger than those admitted to other colleges, and leaving earlier.

**Cavendish Experiment**, an important scientific experiment first made by the celebrated Henry Cavendish, for the purpose of ascertaining the mean density of the earth by means of the torsion balance.

**Ca'very**, or CAUVERY, a river of Southern India, which, after a winding s.e. course of about 470 miles, falls into the Bay of Bengal by numerous mouths. It is known to devout Hindus as the Ganges of the South, and is largely utilized for irrigation purposes.

**Caverypauk**, a town, Hindustan, North

Arcot district, Madras presidency, where Clive gained a victory over the French in 1752. Pop. 5478.

**Cave-temple**, a cave used as a temple; but the name is especially applied to temples excavated in the solid rock, such as exist in considerable numbers in India. See *Elephanta*, *Ellora*.

**Caviare** (kav'i-ār), the roes of certain large fish prepared and salted. The best is made from the roes of the sterlet and sturgeon, caught in the lakes or rivers of Russia.

**Cavicorn'nia**, CAVICORNS (L. *carus*, hollow, and *cornu*, a horn), a family of ruminants, characterized by persistent horns (thus differing from the deer) consisting of a bony core and a horny sheath or case covering the bone, in both sexes or in males only. They comprise the antelopes, goats, and oxen. In various species, as the antelopes, the bony nucleus has no internal cavity; in others, as the ox and goat, it is hollow.

**Ca'vidæ**, the guinea-pig tribe. See *Cavy*.

**Cavite** (ká-vē'tā), a town in the island of Luzon, one of the Philippines; situated on the Bay of Manila, about 11 miles s. w. of Manila. Its docks and arsenal were once famous. It was seized by Com. Dewey after the battle of Manila, as a base of supplies and of convalescence for his sick and wounded. It is retained as such by the U. S. Pop. of town about 7000.

**Cavo-rilievo** (It.; kã'vō-ri-li-ã'vō), in sculpture, a kind of relief in which the high-



Cavo-rilievo.—Wall Sculpture, Great Temple of Philæ, Egypt.

est surface is only level with that of the original stone, giving an effect like the impression of a seal in wax. It is also called *intaglio rilievato*.

**Cavour** (ká-vör'), COUNT CAMILLO BENSO DI, a distinguished Italian statesman, was

born at Turin in 1809 or 1810, died 1861. He was educated in the military academy at Turin, and after completing his studies he made a journey to England, where he remained for several years, making himself



Count Cavour.

acquainted with the principles and working of the British constitution, and forming friendships with some of the most distinguished men. He became a member of the Sardinian Chamber of Deputies in 1849, and the following year minister of commerce and agriculture. In 1852 he became premier, and not long afterwards took an active part in cementing an alliance with Great Britain and France, and making common cause with these powers against Russia during the Crimean War. The attitude, however, thus taken by Sardinia could not fail to prove offensive to Austria. A collision, therefore, was inevitable, resulting in the campaign of 1859. The intimate connection formed at that time with France, who lent her powerful assistance in the prosecution of the war, was mainly due to the agency of Cavour, who was accused by some on this occasion of having purchased the assistance of Napoleon III. by unduly countenancing his ambitious projects. In 1860 Garibaldi's expedition to Sicily took place; but towards this and the subsequent movements of the Italian liberator Count Cavour was forced to maintain an apparent coldness. He lived to see the meeting of the first Italian parliament, which decreed Victor Emmanuel king of Italy.

**Ca'vy**, the popular name for a genus of rodent animals (*Cavia*), family Cavidæ, characterized by molars without roots, fore-

feet with five toes, hinder with three, and the absence of a tail and clavicles. They are natives of tropical America, the most familiar example of this genus being the guinea-pig (which see).

**Cawnpore'**, a town, India, North-west Provinces, on the right bank of the Ganges, which is here about a mile wide, 130 miles N.W. from Allahabad, 628 miles N.W. of Calcutta, and 266 miles S.E. of Delhi. It is a modern town with nothing specially noteworthy about it as regards site or buildings. It has manufactures of leather and cotton goods and a large trade. Including the native city, cantonments, and civil station, it had in 1891 a pop. of 182,310.

In 1857 the native regiments stationed here mutinied and marched off, placing themselves under the command of the Rajah of Bithoor, the notorious Nana Sahib. General Wheeler, the commander of the European forces, defended his position for some days with great gallantry, but, pressed by famine and loss of men, was at length induced to surrender to the rebels on condition of his party being allowed to quit the place uninjured. This was agreed to; but after the European troops, with the women and children, had been embarked in boats on the Ganges, they were treacherously fired on by the rebels; many were killed, and the remainder conveyed back to the city, where the men were massacred and the women and children placed in confinement. The approach of General Havelock to Cawnpore roused the brutal instincts of the Nana, and he ordered his hapless prisoners to be slaughtered, and their bodies to be thrown into a well. The following day he was obliged, by the victorious progress of Havelock, to retreat to Bithoor. A memorial has since been erected over the scene of his atrocities, and fine public gardens now surround the well.

**Caxamarca**, or CAJAMARCA (kâ-hâ-mâr'-kâ), a department and town, Peru; area of the department about 14,200 square miles; pop. 213,400. The town is situated about 70 miles from the Pacific Ocean, 280 N. Lima. Pop. 18,400. It was the scene of the imprisonment and murder of Atahualpa, the last of the Incas.

**Caxias** (kâ-shē'ās), a town of Brazil, province Maranhão, on the Itapicuru, which is here navigable. Pop. 10,000.

**Caxton**, WILLIAM, the introducer of the art of printing into Britain, was born in the Weald of Kent about 1422, died at Westminster 1491. He served an apprentice-

ship to Robert Large, a London mercer. On the death of his master Caxton went into business for himself at Bruges. He was afterwards appointed governor at Bruges to the London Association of Merchant Adventurers. He appears subsequently to have held some office in the household of Charles, Duke of Burgundy, whose wife, the Lady Margaret of York, distinguished herself as the patroness of Caxton. He had translated the popular

mediæval romance *Le Recueil des Histoires de Troye* (Collection of the Histories of Troy), and in order to multiply copies he learned the newly-discovered art of printing. It was printed either at Cologne or Bruges about 1474, and is the earliest specimen of typography in the English language. The *Game and Playe of the Chesse*, Bruges, 1475, is the second English book printed. In 1476 he returned to England, and in 1477 printed at Westminster *The Dictes*



Cawnpore.—From a Drawing by W. Carpenter.

and Sayings of the Philosophers, the first book printed in England. In fourteen years he printed nearly 80 separate books, nearly all of folio size, some of which passed through two editions, and a few through three. He translated twenty-one books, mainly romances, from the French, and one (*Reynard the Fox*) from the Dutch, helping materially to fix the literary language of the 16th century. He was buried in the church of St. Margaret's, Westminster.

**Cayenne** (kī-en'), the capital of the colony of French Guiana, is a seaport on an island of same name at the mouth of the Cayenne River. It is a noted penal settlement, has a large but shallow harbour, and contains about 8000 inhabitants.

**Cayenne Pepper**, or **CAPSICUM**, the name given to the powder formed of the dried and ground fruits, and more especially the seeds, of various species of *Capsicum*, and especially of *C. frutescens*. It is employed as a

condiment to improve the flavour of food, aid digestion, and prevent flatulence. In medicine it is used as a stimulant, and is a valuable gargle for a relaxed throat. See *Capsicum*.

**Caylus** (kā-lūs), ANNE CLAUDE PHILIPPE DE TUBIÈRES, &c., COUNT, French archaeologist, born 1692 at Paris, died 1765. After having served in the army, he travelled extensively in Europe and the East. He left numerous works, tales as well as antiquarian researches. Among the latter is his *Recueil d'Antiquités Egyptiennes, &c.* (Paris, 1752-67, seven vols.). Caylus was also an industrious and skilful engraver, after the first masters. His mother, Marquise de Caylus (1673-1729), niece of Mad. de Maintenon, made herself known by a spirited little work, *Mes Souvenirs*.

**Cayman.** See *Caiman*.

**Cayman Islands**, three islands situated about 140 miles N.W. of Jamaica, of which

they are dependencies. Grand Cayman, the largest and the only one inhabited, is 20 miles long and from 7 to 10 broad, and has two towns or villages. The inhabitants, about 2500 in number, partly descendants of the buccaneers, are chiefly employed in catching turtle. The other two islands are Little Cayman and Cayman Brac (pop. 400).

**Cayu'ga Lake**, a lake in the State of New York, 38 miles long and from 1 to 3½ miles wide. It is much frequented by pleasure parties.

**Cazalla-de-la-sierra** (kâ-thâl'yâ-), a town, Spain, Andalusia, in the province and 36 miles N. by E. of Seville, on a declivity of the Sierra Morena, which is here rich in timber and metals. Pop. 8322.

**Cazembe's** (kâ-zem'be) **Dominion**, a native state of Central South Africa, lying between the rivers Luapula and Lualaba, west of Lake Bangweolo, and now included in the Congo State. It is a land of forest-covered sandstone ridges and grass plains, intersected by streams flowing northwards. The country is vassal to the Muata Yamvo, the hereditary chief of Ulunda. Cassava, maize, sorghum, and cotton are cultivated.

**Cazorla** (kâ-thor'là), a town, Spain, Andalusia, in the province and 41 miles E. of Jaen, with 7383 inhabitants.

**Cazotte** (kâ-zot), JACQUES, French writer, born in 1720, executed by the revolutionists 1792. He became first known by a romance of chivalry, *Ollivier*, published in 1763; and subsequently his *Diable Amoureux*, the *Lord Impromptu*, and *Œuvres Morales et Badines*, gave proof of his rich imagination. With the assistance of an Arabian monk he translated four volumes of *Arabian Tales*—a continuation of the *Arabian Nights*.

**Ceará** (sā-à-rá'), a province on the north coast of Brazil; area, 50,247 square miles. Among its productions are numerous medicinal plants, gums, balsams, and resins; cotton, coffee, sugar-cane, &c., are cultivated. The first Portuguese colony in Ceará was founded in 1610, in the neighbourhood of Ceará, the present capital. This town is situated on the coast, and carries on a considerable trade in rubber, coffee, sugar, &c. Pop. of prov. 952,625; of town Ceará, 35,000.

**Cebadilla**. See *Sabadilla*.

**Cebu** (thā-bö'), one of the Philippine Islands, lying between Luzon and Mindanao, 135 miles long, with an extreme width of 30 miles. Sugar cultivation and

the manufacture of abaca are the chief industries. Pop. 320,000. The town of Cebu, on the eastern coast of the island, the oldest Spanish settlement on the Philippines, is a place of considerable trade, and has a cathedral and several churches.

**Ce'bus**, a genus of monkeys. See *Capuchin* and *Sapajou*.

**Cecco d'Ascoli** (chek-o-dás'ko-lē), whose proper name was FRANCESCO DEGLI STABILI, Italian poet, born at Ascoli 1257, burned at Florence 1327. His chief work, *L'Acerba*, a kind of poetic cyclopædia, passed through many editions. He adversely criticised the writings of Dante and Cavalcante, and suffered death at the hands of the inquisition for alleged heterodoxy.

**Cecidomy'ia**, the genus of insects to which the Hessian-fly belongs.

**Cecil** (ses'il), ROBERT, Earl of Salisbury, English statesman, second son of William Cecil, Lord Burleigh, born about 1563. He was of a weak constitution, on which account he was educated at home till his removal to the University of Cambridge. Having received the honour of knighthood he went to France as assistant to the English ambassador. On the death of Sir Francis Walsingham he succeeded him as principal secretary, and continued to be a confidential minister of Queen Elizabeth to the end of her reign. Having secretly supported the interests of James I. previous to his accession to the crown he was continued in office under the new sovereign and raised to the peerage. In 1603 he was created a baron, in 1604 Viscount Cranbourn, and in 1605 Earl of Salisbury. In 1608 Lord Salisbury was made lord high-treasurer, an office which he held till his death in 1612.

**Cecil**, WILLIAM, Lord Burleigh, eminent English statesman, was the son of Richard Cecil, master of the robes to Henry VIII., and was born at Bourne, in Lincolnshire, in 1520, died 1598. He studied at St. John's College, Cambridge, whence he removed to Gray's Inn, with a view to prepare himself for the practice of the law, but an introduction to the court of Henry VIII. changed his aims. On the accession of Edward VI. his interests were advanced by the protector Somerset, whom he accompanied in the expedition to Scotland. He held no public office during the reign of Mary, and by extraordinary caution managed to escape persecution. On the accession of Elizabeth he was appointed privy-councillor and secretary of state, and during all the rest of his life



he was at the helm of affairs. One of the first acts of her reign was the settlement of religion, which Cecil conducted with great skill and prudence, considering the difficulties to be encountered. The general tenor of



William Cecil, Lord Burleigh.

Cecil's policy was cautious, and rested upon an avoidance of open hostilities, and a reliance on secret negotiation and intrigues with opposing parties in the neighbouring countries, with a view to avert the dangers which threatened his own. On the suppression of the northern rebellion in 1571 Elizabeth raised him to the peerage by the title of Baron Burleigh. Much of the glory of the reign of Elizabeth is due to the counsels and measures of Cecil. His character in private life was very attractive.

**Cecil'ia**, SAINT, the patron saint of music, who has been falsely regarded as the inventress of the organ, and who is said to have suffered martyrdom A.D. 230, although other dates are given. In the Roman Catholic Church her festival (Nov. 22) is made the occasion of splendid music. Her story forms one of Chaucer's Canterbury Tales, and Dryden in his *Alexander's Feast*, and Pope in his *Ode on St. Cecilia's Day*, have sung her praises. Raphael, Domenichino, Dolce, and Mignard, have represented her in celebrated paintings.

**Cecro'pia**, a genus of beautiful South American trees, nat. order Artocarpaceæ (bread-fruits). *C. peltāta*, or trumpet-wood, is remarkable for its hollow stem and branches, the former being made by the

Indians into a kind of drum and the latter into wind-instruments. The light porous wood is used by the Indians for procuring fire by friction. The inner bark is fibrous and strong, and used for cordage. This species yields caoutchouc.

**Cecropia Moth** (*Platysamia cecropia*), the largest moth of the U. States. It belongs to the silk-worm family, and its caterpillar spins a large cocoon from which a coarse silk may be prepared.

**Ce'crops**, according to tradition, the founder of Athens and the first king of Attica. He was said to have taught the savage inhabitants religion and morals, and made them acquainted with the advantages of social life. By the later Greeks he was represented as having led a colony to Attica from Egypt about 1400 or 1500 B.C., but modern critics do not look upon this event nor on the life of Cecrops at all as historical.

**Ce'crops**, a genus of parasitic entomostracous crustaceans, found on the gills of the tunny and turbot, and called by fishermen fish-lice.

**Ce'dar**, a tree which forms fine woods on the mountains of Syria and Asia Minor, the *Pinus Cedrus* of Linnæus, the *Cedrus Libāni* of some other botanists, while by others it is referred to the genus *Larix*, and by others again, along with the larch, to the genus *Abies*. It is an evergreen, grows to a great size, and is remarkable for its durability. Of the famous cedars of Lebanon comparatively few now remain, and the tree does not grow in any other part of Palestine. The most celebrated group is situated not far from the village of Tripoli, at an elevation of about 6000 feet above the sea. The circumference of the twelve largest trees here varies from about 18 to 47 feet. Cedar timber was formerly much prized, but in modern times is not regarded as of much value, perhaps from the trees not being of sufficient age. Some fine cedars are met with in England. The name is given also to the deodar (*C. Deodāra*), which is indeed regarded by many botanists as a mere variety of the cedar of Lebanon, and which produces excellent timber. It is a native of India, and is a large and handsome tree, growing in the Himalayas to the height of 150 feet, with a circumference of 30. It has wide-spreading branches, which droop a little at the extremities. The leaves are tufted or solitary, larger than those of the cedar of Lebanon and very numerous, of a dark-bluish green, and covered with a

glaucous bloom. The cones are rather larger than those of the Lebanon cedar, and very resinous. The wood is well adapted for building purposes, being compact and very enduring. The deodar was introduced into



Cedar of Lebanon.

Great Britain in 1822, and is now common in lawns and parks. The Mount Atlas cedar (*C. Atlantica*), as its name implies, is a native of the mountains of North Africa. This cedar, though differing in habit and minor features, is regarded by some botanists as specifically identical with the other two. The name is also applied to many trees which have no relation to the true cedar, as the Bermuda cedar (*Juniperus bermudiāna*), used for making pencils, the red cedar (*J. virginiana*), the Honduras, or bastard Barbadoes cedar (*Cedrela odorata*), and the red cedar of Australia (*C. australis*). See *Cedrela*.

**Cedar-bird**, a name given to the American wax-wing (*Ampelis americanus* or *Bombycilla carolinensis*), from its fondness for the berries of the red cedar. It is a handsome and sprightly bird, occurring throughout the whole of the United States, but has no song.

**Cedar Creek**, a stream in Shenandoah co., Virginia, near which General Sheridan converted a defeat of the Federals by the Confederates into a complete victory, Oct. 1864.

**Cedar Lake**, a lake in Canada, an expan-

sion of the Saskatchewan before it enters Lake Winnipeg; nearly 30 miles long, and where widest 25 miles broad.

**Cedar Oil**, an aromatic oil obtained from the American red cedar (*Juniperus virginiana*).

**Cedar Rapids**, a flourishing city of the U. States, in Iowa, on Red Cedar River, with large railway machine-shops and numerous industrial establishments. Pop. 1890, 18,020.

**Cedil'la**, a mark used under the letter *c*, especially in French (thus ç), to indicate that it is to be pronounced like the English *s*.

**Cedre'la**, a genus of large timber trees, natives of the tropics of both hemispheres, order Cedrelaceæ. *C. odorata* of Honduras and the W. Indies yields bastard cedar; *C. australis* is a valuable Australian timber tree; one or two E. Indian species have febrifugal properties.

**Cedrela'ceæ**, the mahogany family, a nat. order of dicotyledonous plants, nearly allied to, if really separate from, the Meliaceæ. They are trees with alternate pinnate leaves and a woody capsular fruit. Different species yield mahogany, satin-wood, yellow-wood, &c.

**Ced'rus**. See *Cedar*.

**Cefalo'nia**. See *Cephalonia*.

**Cefalu** (chef'â-lö), a seaport and bishop's see on the north coast of Sicily. The trade is trifling, but a productive fishery is carried on. Pop. 12,714.

**Cel'andine**, a name given to two plants, the greater celandine and the lesser celandine; also called *swallow-warts*, because the plants were believed to flower when the swallow arrived, and to die when it departed. The former is *Chelidonium majus*, and the latter *Ficaria ranunculoides* or *Ranunculus Ficaria*. This latter is a favourite wild flower from its being one of the earliest plants to come into blossom, having petals of a fine golden yellow colour. Its root consists of small fleshy tubers. It is often called *pilewort*, being a reputed cure of piles. The greater celandine belongs to the poppy family; it is full of a yellow juice of a poisonous acrid nature.

**Celano** (che-lä'nō), LAKE OF. See *Fucino*.

**Celano** (che-lä'nō), TOMMASO DA, one of the reputed authors of the Latin hymn Dies Iræ, was born towards the end of the 12th or about the beginning of the 13th

century, at Celano, in the Abruzzi, and died in Italy after 1250. He was one of the most devoted adherents of St. Francis of Assisi, whose life he wrote.

**Celastra'ceæ**, an order of polypetalous dicotyledons, consisting of shrubs and small trees, natives of S. Europe, Asia, America, Australia, &c., most of them of no great importance. See *Spindle-tree*.

**Celebes** (sel'e-bēz), one of the larger islands of the Indian Archipelago, between Borneo on the w. and the Moluccas on the E. It consists mainly of four large peninsulas stretching to the E. and S., and separated by three deep gulfs; total area, 54,000 sq. miles. No part of it is more than 70 miles from the sea. Celebes is mountainous chiefly in the centre and the north, where there are several active volcanoes. It has also broad grassy plains and extensive forests. Gold is found in all the valleys of the north peninsula, which abounds in sulphur. Copper occurs at various points, and in Macassar tin also. Diamonds and other precious stones are found. The island is entirely destitute of feline or canine animals, insectivora, the elephant, rhinoceros, and tapir (though these are found in Borneo); but it has the antelopean buffalo (*Anoa*), the spiral-tusked pig (*Babyroussa*), &c. Among domesticated animals are small but vigorous horses, buffaloes, goats, sheep, and pigs. Trepan and turtle are caught in abundance. Marsupial animals are represented by the cuscus, an opossum-like animal with a prehensile tail. Among the trees are the oak, teak, cedar, upas, bamboo, &c. Among cultivated plants are the coffee-tree, indigo, cacao, sugar-cane, manioc root, tobacco, &c. The maritime districts are inhabited by Malays; the Peninsula of Macassar is occupied by Bugis and Macassars. Mandhars dwell in the w. of the island, and the mountainous regions in the interior, especially in the N., are inhabited by Alfoories. The inhabitants may be classed into two groups: the Mohammedan semi-civilized tribes, and the pagans, who are more or less savages. The capital is Macassar, in the s.w. of the island. The trade in trepan is very important, Macassar being the chief staple place for this article of commerce. The three great languages of the island, not reckoning the dialects of the savage tribes, are those of the Bugis, the Macassars, and the Mandhars. The ancient Bugi is the language of science and religion. The Bugis have a considerable body of literature.

Celebes was first visited by the Portuguese in 1512, but no factory was established by them there till a few years later. In 1660 Macassar was taken by the Dutch, the southern portion of the island put under Dutch rule, and the Portuguese expelled. In 1683 the northern part likewise fell into their hands. The island was conquered by the British in 1811, but a few years later it was again given up to the Dutch, in whose possession it has remained ever since. Pop. estimated at 1,000,000.

**Cel'eres**, in Roman antiquity, a body of 300 horsemen, formed by Romulus from the wealthier citizens. Their number was afterwards augmented, and they are thought to have been the origin of the *equites*.

**Celer'iac**, turnip-rooted celery, a variety of celery in which the root resembles a turnip and may weigh 3 or 4 lbs. It is not earthed up, but is grown upon the surface of the ground, and kept free from weeds by frequent hoeing.

**Cel'ery**, an umbelliferous plant (*Apium graveölens*) indigenous in the temperate parts of Europe. In its native station it has the character of being a poisonous plant, but transplanted to a garden it becomes a wholesome vegetable. It is much cultivated in the U. S., principally two varieties, red and white stalked, and of these many sub-varieties. Celery is commonly blanched by heaping up the soil about the plants.

**Celery Fly** (*Tephritis Onopordinis*), a two-winged fly, the larvæ of which are destructive to celery and parsnip.

**Cel'estine** (Sr SO<sub>4</sub>), the native sulphate of strontium, a mineral which occurs associated with sulphur and finely crystallized in the Sicilian sulphur mines. It is transparent and colourless, though specimens are met with of a yellow or red colour, while others are of a fine blue. It is from this variety that the mineral has obtained its name.

**Celestine**, the name of five popes. CELESTINE I. was elected pope in 422, died in 432, and is recognized by the church as a saint.—CELESTINE II., a native of Tuscany, who had studied under Abelard, filled the papal chair for five months in 1143-44. He granted absolution to Louis VII. of France, and removed the interdict which for three years was laid upon that country.—CELESTINE III., one of the Orsini family, was elected pope in 1191, when, it is believed, about ninety years of age, and reigned till 1198. He crowned the emperor Henry VI., but afterwards excommunicated both Henry

and Leopold, duke of Austria, on account of the captivity of Richard Cœur de Lion.—CELESTINE IV., a Milanese, who, when a monk, wrote a history of Scotland, was elected pope in 1241, but reigned only seventeen days.—CELESTINE V. was chosen pope July 5, 1294, but abdicated his dignity Dec. 13, 1294, and died May 19, 1296. He is the founder of the Celestines, and was canonized in 1313 by Clement V.

**Cel'estines** (from their founder Pope Celestine V.), a religious order instituted about the middle of the 13th century, in Italy, who followed the rule of St. Benedict, and were devoted entirely to a contemplative life. Very few priories of this once-numerous order now exist.

**Cel'ibacy**, the state of being celibate or unmarried; specially applied to the voluntary life of abstinence from marriage followed by many religious devotees and by some orders of clergy, as those of the Roman Catholic Church. The ancient Egyptian priests preserved a rigid chastity; the priestesses of ancient Greece and Rome were pledged to perpetual virginity; and celibacy is the rule with the Buddhist priests of the East. Among Christians the earliest aspirants to the spiritual perfection supposed to be attainable through celibacy were not ecclesiastics as such, but hermits and anchorites who aimed at superior sanctity. During the first three centuries the marriage of the clergy was freely permitted, but by the Council of Elvira (305) continence was enjoined on all who served at the altar. For centuries this subject led to many struggles in the church, but was finally settled by Gregory VII. positively forbidding the marriage of the clergy. The Council of Trent (1593) confirmed this rule. In the Greek Church celibacy is not compulsory on the ordinary clergy. Protestants hold that there is no moral superiority in celibacy over marriage, and that the church has no right to impose such an obligation on any class of her ministers.

**Cell**, a term of various applications. (1) Ecclesiastically it was sometimes applied to a lesser or subordinate religious house, dependent upon a greater. The apartments or private dormitories of monks and nuns are also called *cells*. The term *cell* is applied also to the part of the interior of a temple where the image of a god stood. (2) In electricity, the term is applied to a single jar, bath, or division of a compound vessel, containing a couple of plates, generally copper

and zinc, united to their opposites or to each other, usually by a wire. (3) In biol. a *cell* is a microscopically small semi-fluid portion of matter, consisting of a soft mass of living, contractile, jelly-like matter, and a

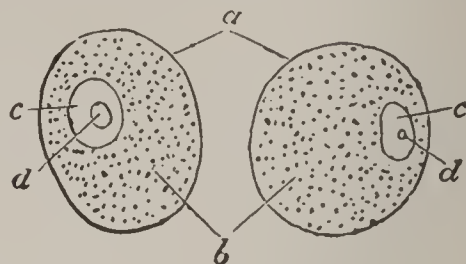

Cells of Round or Oval Form.

a, Border of the cell or cell-wall; b, cell substance; c c, nuclei; d d, nucleoli.

central structure, consisting of a small, roundish body, called the *nucleus*, generally more solid than the rest of the cell, and which may have within it a still more minute body, the *nucleolus*. The cell substance or protoplasm (see *Protoplasm*) which surrounds the nucleus is an albuminous substance possessing fundamental vital properties, and believed to be the starting-point of all animal and vegetable organisms. The cell-wall when present consists of an alteration of the external portion of the cell body, and is not a separate structure. All cells have but a very limited duration, so the tissues are being constantly renewed.

**Cella**, part of a temple. See *Cell*.

**Cellardyke**. See *Anstruther*.

**Celle** (tsel'le), a town in Prussia, province of Hanover, 23 miles N.E. of the town of Hanover, in the midst of a sandy plain, at the confluence of the Fuse with the Aller, which is navigable. The manufactures are varied, and the trade is extensive. Pop. 18,800.

**Cellini** (chel-lé'nē), BENVENU'TO, a sculptor, engraver, and goldsmith, was born at Florence in 1500, and died there in 1571 or 1572. Of a bold, honest, and open character, but vain and quarrelsome, he was often entangled in disputes which frequently cost his antagonists their lives. At the siege of Rome (if we believe his own account, given in his autobiography) he killed the Constable of Bourbon and the Prince of Orange. He was afterwards imprisoned on the charge (probably false) of having stolen the jewels of the Papal crown, and with difficulty escaped execution. He then visited the court of Francis I. of France. He afterwards returned to Florence, and under the patronage of Cosmo de' Medici made a Per-

seus with the head of Medusa in bronze, which is still an ornament of one of the public squares; also a statue of Christ, in the chapel of the Pitti Palace, besides many excellent dies for coins and medals. His works may be divided into two classes. The first, for which he is most celebrated, comprises his smaller productions in metal, the embossed decorations of shields, cups, salvers, ornamented sword and dagger hilts, clasps, medals, and coins. The second includes his larger works as a sculptor, such as the Perseus mentioned above; a colossal Mars for a fountain at Fontainebleau; a marble Christ in the Escorial Palace; a life-size statue of Jupiter in silver; &c. His life, written by himself, is very racy and animated.

**Cellula'res**, in botany, that division of plants which are altogether composed of cellular tissue, without fibres or vessels. They form the greater portion of the acotyledonous or cryptogamic plants.

**Cellular Theory**, in physiology, that theory which derives all vegetable and animal tissues from the union and metamorphosis of primitive cells.

**Cellular Tissue**, in physiology, a name for what is also called the *areolar tissue* (which see). In botany, the term is applied to the soft substance of plants, composed of elementary vesicles or cells without woody or vascular tissues.

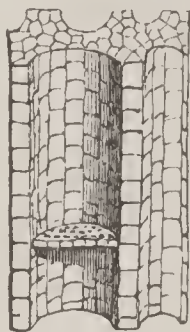

Cellular Tissue in Plants.

**Cell'uloid**, an artificial substance extensively used as a substitute for ivory, bone, hard rubber, coral, &c, having a close resemblance to these substances in hardness, elasticity, and texture. It is composed of cellulose or vegetable fibrine reduced by acids to pyroxyline (or gun-cotton), camphor is then added, and the compound moulded by heat and pressure to the desired shape. It is used chiefly for such articles as buttons, handles for knives, forks, and umbrellas, billiard-balls, backs to brushes, piano keys, napkin-rings, opera-glass frames, &c. It can be variously coloured.

**Cell'ulose** ( $C_6H_{10}O_5$ ), the substance of which the permanent cell-membranes of plants are always composed. It is closely allied to sugar, dextrin, or gum and starch, and is changed into the latter by heat, sulphuric acid, or caustic potash. Cellulose has also been detected in the tunics of ascidia and other invertebrate animals.

**Cel'sius**, the name of a Swedish family, several members of which attained celebrity in science and literature. The best known is ANDERS CELSIUS, born 1701, died 1744. After being appointed professor of astronomy at the University of Upsal he travelled in Germany, England, France, and Italy; and in 1736 he took part in the expedition of Maupertuis and others for the purpose of measuring a degree of the meridian in Lapland. He is best known as the constructor of the Centigrade thermometer.

**Celsius Scale**, another name for the Centigrade thermometric scale, from that of the inventor, Anders Celsius. See *Thermometer*.

**Cel'sus**, an Epicurean philosopher of the 2d century after Christ, who is usually said to have been the author of an attack on Christianity entitled *Logos Alēthēs* (True Word), which is now lost, but is mostly preserved in the extracts contained in the more celebrated work *Contra Celsum*, in which it was answered by Origen.

**Celsus**, AURELIUS (or perhaps AULUS) CORNELIUS, a celebrated Latin writer on medicine who lived, probably, under the Roman emperors Augustus and Tiberius, or in the beginning of the Christian era. He also wrote on rhetoric, the art of war, and agriculture. He is, however, best known by his *De Medicina*, long one of the chief manuals on medicine.

**Celtibe'ri**, or CELTIBERIANS, inhabitants of Celtiberia, now known as Old and New Castile. They originated from Iberians mixed with Celts. After a long resistance to the Romans they were at last subjected to their sovereignty, adopted their manners, language, dress, &c.

**Celtis**, a genus of trees. See *Nettle-tree*.

**Celts**, the earliest Aryan settlers in Europe according to the common theory. They appear to have been driven westward by succeeding waves of Teutons, Slavonians, and others, but there are no means of fixing the periods at which any of these movements took place. Herodotus mentions them as mixing with the Iberians who dwelt round the river Ebro in Spain. At the beginning of the historic period they were the predominant race in Britain, Ireland, France, Belgium, Switzerland, N. Italy, Spain, and elsewhere. The Romans called them generally Galli, that is Gauls or Gael. They appear to have reached the zenith of their power in the 2d and 3d centuries B.C. Some tribes of them, overrunning Greece, settled in a part of Asia Minor, to which the name

of Galatia was given. They finally went down before the resistless power of Rome, and either became absorbed with the conquering races or were cooped up in the extreme N.W. of Europe. At an early date the Celts divided into two great branches, speaking dialects widely differing from each other, but doubtless belonging to the same stock. One of these branches is the Gaelic or Gaelic, represented by the Highlanders of Scotland, the Celtic Irish, and the Manx; the other is the Cymric, represented by the Welsh, the inhabitants of Cornwall, and those of Brittany. The Cornish dialect is now extinct. The sun seems to have been the principal object of worship among the Celts, and groves of oak and the remarkable circles of stone commonly called 'Druidical Circles,' their temples of worship. All the old Celts seem to have possessed a kind of literary order called Bards. The ancient Irish wrote in a rude alphabet called the Ogham (which see); later they employed the Roman alphabet, or the Anglo-Saxon form of it. The chief literature existing consists of the hymns, martyrologies, annals, and laws of Ireland, written from the 9th to the 16th centuries. The Scottish Gaelic literature extant includes a collection of MSS. in the Advocates' Library, Edinburgh, some of which date from the 12th century; the Book of the Dean of Lismore, 16th century; a number of songs from the 17th century to the present day; and the so-called poems of Ossian (which see). The Welsh literary remains date from the 9th century, and consist of glossaries, grammars, annals, genealogies, histories, poems, prose tales, &c.

**Celts** (Late Latin *celtis*, a chisel), the name given to certain prehistoric weapons or other implements of stone or bronze which have been found over nearly the whole surface of the earth. Stone celts are found in the form of hatchets, adzes, chisels, &c. In size they vary, some being found only about 1 inch in length, and others approaching 2 feet; but the most common length is from 6 to 8 inches, and the breadth is usually about  $\frac{1}{2}$  or  $\frac{1}{3}$  of the length. The materials of which they are made are flint, chert, clay-slate, porphyry, various kinds of greenstone

and of metamorphic rocks, and, in short, any very hard and durable stone. Bronze celts belong to a later period than stone ones, and are not so numerous. Some stone celts, however, have been found along with bronze celts in such a manner as to show that stone celts were still used when the method of working bronze had been discovered, a circumstance that need not be wondered at. Bronze celts are not found so large as the largest stone celts, the largest bronze celt being under 1 foot; but the average size of a bronze celt is about the same as that of a stone, namely about 6 inches.

**Cembra Pine** (*Pinus Cembra*), a fine conifer of Central Europe and Siberia, having edible seeds and yielding a turpentine called Carpathian balsam. Swiss stone pine and Siberian pine are also names given to it.

**Cementation**, the conversion of iron into steel by heating the iron in a mass of ground charcoal, and thus causing it to absorb a certain quantity of the charcoal.

**Cements**, the general name for glutinous or other substances capable of uniting bodies in close cohesion. In building the name is given to a stronger kind of mortar than that which is ordinarily used, consisting of those hydraulic limes which contain silica and therefore set quickly. Cements are variously composed, according to the nature of the surfaces to which they are applied and their exposure to heat or moisture. *Hydraulic* or *water cements* harden under water and consolidate almost immediately on being mixed. Of this kind are the Roman and Portland cements.

**Cemetery**. See *Burying-places*.

**Cenci** (chen'chē), BEATRICE, called the *beautiful parricide*, the daughter of Francesco Cenci, a noble and wealthy Roman (1527-98), who, according to the common story, after his second marriage, behaved towards the children of his first marriage in the most shocking manner, procured the assassination of two of his sons, on their return from Spain, and debauched his youngest daughter Beatrice. She failed in an appeal for protection to the pope, and planned and executed the murder of her father. She was beheaded 1599 and the Cenci estates confiscated. She is the alleged subject of an admired painting by Guido,



Bronze Celt.



Bronze Celts.

and is the heroine of one of Shelley's most powerful plays. Recent researches have deprived the story of most of its romantic elements, and have shown Beatrice to be a very commonplace criminal, whatever the evil deeds of her father may have been. Her stepmother and brother, who were equally guilty with her, were also executed. The portrait by Guido is now believed not to represent her at all.

**Cenis** (sè-nē') MOUNT, a mountain belonging to the Graian Alps, between Savoy and Piedmont, 11,755 feet high. It is famous for the winding road constructed by Napoleon I. which leads over it from France to Italy, and for an immense railway tunnel, which, after nearly fourteen years' labour, was finished in 1871. The tunnel does not actually pass through the mountain, but through the Col de Fréjus, about 15 miles to the s.w., where it was found possible to construct it at a lower level. The Mount Cenis Pass is 6765 feet above the level of the sea, whereas the elevation of the entrance to the tunnel on the side of Savoy is only 3801 feet, and that on the side of Piedmont 4246 feet. The total length of the tunnel is 12,849 metres (42,145 feet, or nearly 8 miles). The total cost amounted to £2,600,000, which was borne partly by the French and Italian governments and partly by the Northern Railway Company of Italy. The tunnel superseded a grip railway which was constructed over the mountain by Mr. Fell, an English engineer, 1864-68.

**Cen'obite**, one of a religious order living in a convent or in community; in opposition to an anchorite or hermit, who lives in solitude.

**Cen'otaph**, a monument erected in honour of a deceased person, but not containing his body, as is implied from the derivation (Gr. *kenos*, empty, and *taphos* a tomb).

**Cen'ser**, a vase or pan in which incense is burned; a vessel for burning and wafting incense. Among the ancient Jews the censer was used to offer perfumes in sacrifices. Censers, called also thuribles, are still used in the Roman Catholic Church at mass, vespers, and other offices, as well as in some Anglican and other churches. They are of various forms. In Shakespeare's time the term was applied to a bottle perforated and ornamented at the top, used for sprinkling perfume, or to a pan for burning any odorous substance.

**Cen'sors**, two officers in ancient Rome who held office for eighteen months, and

whose business was to draw up a register of the citizens and the amount of their property, for the purposes of taxation; to keep watch over the morals of the citizens, for which purpose they had power to censure vice and immorality by inflicting a public mark of ignominy on the offender; and to superintend the finance administration and the keeping up of public buildings. The office was the highest in the state next to the dictatorship, and was invested with a kind of sacred character. The term is now applied to an officer empowered to examine books before publication. See *Books, Censorship of*.

**Cen'sus**, with the Romans a registered statement of the particulars of a person's property for taxation purposes; an enumeration and register of the Roman citizens and their property, introduced by King Servius Tullius B.C. 577. In modern times a census is an enumeration of the inhabitants of a country, accompanied by any other information that may be deemed useful. In most civilized countries such enumerations now take place at fixed intervals. The first census of Great Britain was taken in 1801, and a census has been taken every ten years since that date. The first census that was attempted in Ireland was that of 1811, but the census of that country taken in 1831 is regarded as the first on which reliance can be placed. The first census of the entire British empire was not taken till 1871. The first authentic census in France appears to have been that of 1700; since 1822 it has been taken every five years. The first census in Russia was taken by order of Peter the Great in 1723, and it was decreed that it should be repeated every twenty years. It now takes place more frequently. In Prussia the practice of taking a census of the population dates from the time of Frederick the Great. Even before the formation of the new German Empire all the principal states of Germany had united for purposes of enumeration, and a census was taken every three years. The first census of the new German Empire was taken in 1871, since when there has been a census every five years. In the United States of America, Switzerland, Sweden and Norway, Holland, Belgium, and Portugal, a census is taken every ten years.

**Cent**, CENTIME (sən-tēm), &c., the name of a small coin in various countries, so called as being equal to a hundredth part of some other coin. In the United States and in

Canada the cent is the hundredth part of a dollar. In France the *centime* is the hundredth part of a franc. Similar coins are the *centavo* of Chili; and the *centesimo* of Italy, Peru, &c. Cents or centimes, and their equivalents, are written simply as decimals of the unit of value. The first cent authorized by act of congress (U. States), April 22, 1792, was of copper, weighing 264 grains; reduced in 1793 to 208 grains, in 1796 to 168 grains; discontinued in 1857. The nickel cent, weighing 72 grains, composed of 88 per cent. copper and 12 per cent. nickel, authorized in 1857, was discontinued in 1864. The bronze cent, weight 48 grains, composed of 95 per cent. copper and 5 per cent. of tin and zinc, was authorized in 1857.

**Centau'rea**, a very extensive genus of herbaceous plants, nat. order Compositæ; of no importance.

**Cen'taurs**, in Greek myth. fabulous beings represented as half man, half horse. The earliest notices of them, however, merely represent them as a race of wild and savage men inhabiting the mountains and forests of Thessaly. Mythology relates the combats of the Centaurs with Hercules, Theseus, and Pirithoüs.

The Centaurs Nessus, Chiron, and others are famous in ancient fable.

**Centau'rus**, a constellation of the southern hemisphere, near the south pole, E. and N. of the Southern Cross.

**Cen'taury**, the *Erythræa Centaurium*, an annual herb of the gentian family with pretty red flowers. It is common throughout Europe, and is extolled for its medicinal properties by the old herbalists. It is common in England, especially on dry, sandy, or chalky soils.

**Centa'vo**. See *Cent*.

**Cen'tenary**, the commemoration of any event, as the birth of a great man, which occurred 100 years before.



Centaur.—Antique statue in Vatican Museum.

**Cen'tering**, the framing of timber by which the arch of a bridge or other arched structure is supported during its erection. The same name is given to the woodwork or framing on which any vaulted work is constructed. The centering of a bridge has to keep the stones or *voussoirs* in position till they are keyed in, that is, fixed by the insertion of the requisite number of stones in the centre.

**Centes'imo**. See *Cent*.

**Centiare** (*sân-tyär*), a French measure, the hundredth part of an *are*; a square metre, equal to 1.19 square yards.

**Centigrade**. See *Thermometer*.

**Centime**. See *Cent*.

**Cen'tipede**, a term applied to various insect-like creatures having many feet, and a body consisting of numerous similar rings or segments (*somites*), all belonging to the order Cheilopoda, class Myriapoda. The common centipede, found in the United States, is quite harmless, but those of tropical countries belonging to the genus *Scolopendra* inflict severe and often dangerous bites. They sometimes grow to a foot in length.

**Cent'livre**, SUSANNA, dramatic writer, daughter of a Lincolnshire gentleman named Freeman, was born in Ireland about 1667; died 1723. After being twice left a widow within a short time of her marriage she took for a third husband Joseph Centlivre, chief cook to Queen Anne. She had some success as an actress, but her fame rests on *The Busybody*, *The Wonder*, *A Bold Stroke for a Wife*, and 14 other plays, all of which were published in a collected edition, 1761. Mrs. Centlivre enjoyed the friendship of Steele, Farquhar, Rowe, and other wits of the day.

**Cen'tner**, a common name on the continent of Europe for a hundredweight. In Switzerland it is equal to 110 lbs.; in Austria, 110½; in Sweden, 112.06; in Germany, 110.25.

**Cen'to** (L., a patchwork), a poem formed out of verses taken from one or more poets, so arranged as to form a distinct poem.

**Centorbi**. See *Centuripe*.

**Central America**, a geographical division, including the stretch of territory from the Isthmus of Panama to the Isthmus of Tehuantepec, but by political arrangements the limits most generally assigned to it include the five republican states of Guatemala, Honduras, San Salvador, Nicaragua, and Costa Rica (which see), with British Honduras and the Mosquito Coast. It thus



has Mexico on the n.w., Colombia on the s.e., and the Pacific Ocean and Caribbean Sea on either side. Its entire length may be about 800 miles, with a breadth varying from between 20 and 30 to 350 miles. It is generally mountainous, contains a number of active volcanoes, and on the whole is a rich and fertile, but almost totally undeveloped region. The area is about 175,000 square miles; the pop. 2,700,000.

**Central Asia.** See *Asia, Central*.

**Central Forces**, the forces which cause a moving body on which they act to tend towards or recede from the centre of motion, or that point which remains at rest while all the other parts of a body move round it. The force with which the revolving body tends to fly from the centre is called the *centrifugal force*, and the force which causes it to tend towards the centre of motion is called the *centripetal force*.

**Central Heat.** See *Earth*.

**Central India Agency**, a collection of states in Hindustan, consisting of nine agencies, viz. Indore, Gwalior, Bhopal, Bhil or Bhopawar, Deputy Bhil, Western Malwa, Guna, Bundelkhand, and Baghelkhand under the ultimate charge of the governor-general's agent at Indore. These states cover an area of 75,000 square miles, and have a pop. of 9,261,907.

**Centralization**, a term in a specific sense applied to a system of government where the tendency is to administer by the central government matters which had been previously, or might very well be, under the management of local authorities.

**Central Provinces**, an extensive British territory in India. They became a separate administration in 1861, and are under the authority of a chief commissioner. Their total area is 115,936 square miles, of which 86,501 square miles are British territory, and 29,435 the territory of native protected states, fifteen in number. In 1891 the population, including the native states, was 12,944,805 persons, or 99 to the square mile. For administrative purposes the province is divided into four commissionerships, Jabalpur (Jubbulpore), Nagpur, Nerbada (Nerbudda), and Chhattisgarh.

**Centre-board**, a sort of movable keel used especially in American yachts, and capable of being raised and lowered in a well extending longitudinally amidships. It tends to prevent leeway and gives the vessel greater stability when under a press of canvas.

**Centre of Gravity**, that point of a body through which the line of the resultant of the weights of all the particles composing the body always passes, whatever be the position of the body.

**Centre of Gyration**, the point at which, if the whole mass of a revolving body were collected, the rotatory effect would remain unaltered.

**Centre of Oscillation**, that point of a body suspended by an axis, at which, if all the matter were concentrated, the oscillations would be performed in the same time.

**Centre of Pressure**, that point of a body at which the whole amount of pressure may be applied with the same effect as it would produce if distributed; specifically, in hydrostatics, that point in the side of a vessel containing a liquid, to which, if a force were applied equal to the total pressure and in the opposite direction, it would exactly balance the effort of the total pressure.

**Centrifugal and Centripetal**, in bot., terms applied to two kinds of inflorescence, the former being that in which the terminal or central flower is the first to expand, as in a true cyme (examples, elder and valerian), the latter being that kind in which the lower or outer flower is the first to expand, as in spikes, racemes, umbels, and corymbs. The laburnum, hemlock, and daisy are examples.

**Centrifugal and Centripetal Force.** See *Central Forces*.

**Centurion**, in the ancient Roman army, the commander of a century, or body of 100 men, but afterwards an indefinite number, the sixtieth part of a legion. The rank of a centurion corresponded pretty much to that of a captain in modern armies.

**Centuripe** (chen-tö'ri-pä; anc. *Centuripa*), also called *Centorbi*, a town of Sicily, prov. Catania, situated in a fertile district yielding soda, sulphur, and marble. The ancient city, of which considerable remains exist, was one of the most flourishing of Sicily. Pop. 8711.

**Century** (Latin, *centuria*, from *centum*, a hundred), one of the divisions or companies into which the Roman legions were divided, originally 100 men. This name was also given to the divisions of the six classes of the people introduced by Servius Tullius. According to Livy the first class contained eighty-two, to which were added the eighteen centuries of the knights; the three following classes had each twenty centuries; the fifth, thirty-four; and the sixth only one century.

**Century-plant**, a popular name of the *Agave americana*, or American aloe.

**Ce'os**, an island, Greece. See *Zea*.

**Cepha'ëlis**. See *Ipecacuanha*.

**Cephalas'pis** (Gr. *kephalē*, the head, and *aspis*, a shield), a genus of fossil ganoid fishes occurring in the Old Red Sandstone, belonging to the same order as the bony-pike

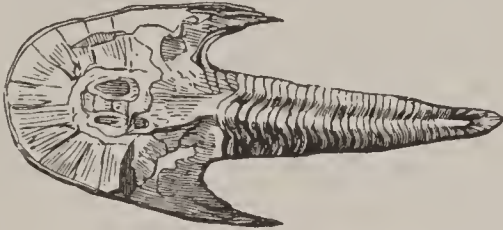

*Cephalaspis Lyellii*.

and sturgeon. They have longish bodies; the head is large and crescent-shaped, bearing a close resemblance to the shape of a saddler's knife, and is protected by a large buckler-shaped plate which is prolonged into a point on either side.

**Cephaliza'tion**, in biol. a term proposed to denote a tendency in the development of animals towards a localization of important parts in the neighbourhood of the head, as by the transfer of locomotive members or limbs to the head (in the Cephalopoda, for example). The term is also used to indicate the degree in which the brain dominates over the other parts of the animal structure.

**Cephalo'nia** (ancient *Kephallenia*), an island of Greece, the largest of the Ionian islands, w. of the Morea, at the entrance of the Gulf of Patras, about 31 miles in length, and from 5 to 12 in breadth; area, 348 square miles; pop. 80,543. The coastline is very irregular and deeply marked with indentations, and the surface is rugged and mountainous, rising in Monte Negro, the ancient *Ænos*, to a height of 5380 feet. There is rather a deficiency of water on the island. The principal towns are Argostoli (9000 inhabitants) and Lixuri (6000). The chief exports are currants, oil, and grain; wine, cheese, &c., are also exported. The manufactures are inconsiderable. Earthquakes are not infrequent. One of the most destructive was that of the year 1867. See *Ionian Islands*.

**Cephalop'oda**, CEPHALOPODS (Gr. *kephalē*, head; *pous*, *podos*, foot), a class of the mollusca, the highest in organization in that division of the animal kingdom, characterized by having the organs of prehension

and locomotion, called tentacles or arms, attached to the head. The arms are furnished with numerous suckers, and enable them to cling to and entangle their prey; and they have a pair of well-developed jaws and eyes. They are divided into two sections, Tetrabranchiata (four-gilled) and Dibbranchiata (two-gilled). The nautilus and the fossil genera *Orthoceras*, *Ammonites*, *Goniatites*, &c., belong to the Tetrabranchiata, in which the animal has an external shell. The dibbranchiate group includes the argonaut, the octopus or eight-armed cuttlefishes, and the ten-armed forms, as the calamaries, the fossil belemnites, &c. The shell is in all these internal (being known as the 'pen' and the 'cuttle-bone'), in some rudimentary. The fossil Cephalopoda are multitudinous. See *Argonaut*, *Calamary*, *Nautilus*, *Sepia*, &c.

**Cephalop'tera** (Gr. *kephalē*, head; *pteron*, a wing), a genus of cartilaginous fishes of the ray family, having a pair of little fins which stand out from the head like horns; hence called fin-headed rays or horned rays. Only one species (*C. Giorna*) has been found near the British coasts.

**Cephalotho'rax**, the anterior segment in spiders, scorpions, crustaceans, &c., consisting of the head and thorax combined.

**Cepheus** (sē'fūs), a king of Ethiopia and husband of Cassiopeia; his name was given to a constellation of stars in the northern hemisphere surrounded by Cassiopeia, Ursa Major, Draco, and Cygnus.

**Ceram'**, an island in the Moluccas, lying west of New Guinea; area about 7000 sq. miles; pop. estimated at 200,000. It is about 200 miles long with an average width of 35 miles. Its interior is traversed by mountain ranges from 6000 to 8000 feet high, but is little known. The vegetation is luxuriant, the sago-palm supplying the chief food of the inhabitants as well as an article of trade. The inhabitants of the coast are of Malay origin, the interior being peopled by Alfoories. It is under the Dutch.

**Ceramia'ceæ**, a natural order of cellular sea-weeds (Algæ), consisting of thread-like jointed plants of a red or brown-red colour. The spores are in masses in transparent membranous sacs, and the tetraspores are external. The *Chondrus crispus*, or carrageen moss; the *Rhodomenia palmata*, or dulse; and the *Plocaria tenax*, extensively used by the Chinese as a glue and varnish, belong to this order.

**Ceram'ic Art**, that department of plastic art which comprises all objects made of baked clay, as vases, cups, urns, bassi-rilievi, statuettes, &c., and including all the varieties of earthenware and porcelain which can be regarded as works of art.

**Ceras'tes** (Gr., from *keras*, a horn), a genus of African vipers, remarkable for their fatal venom, and for two little horns formed by



*Cerastes vulgaris.*

the scales above the eyes. Hence they have received the name of horned vipers. The tail is very distinct from the body. *C. vulgaris* is the horned viper of Northern Africa, a species known to the ancients. There are several other species.

**Cer'asus**, the cherry genus of trees.

**Ce'rate**, the name of an external medication, more or less liquid, having for its basis wax and oil. Simple cerate consists of 8 oz. of lard and 4 of white wax melted together and stirred till cold.

**Cerat'odus**, a genus of fishes belonging to the Dipnoi or lung-fishes. It is the barramunda or native salmon of the Australian rivers, measures from 3 to 6 feet in length, and forms an interesting connecting link between the oldest surviving group of fishes and the lowest air-breathing animals. It is said to leave the water and go on the flats after vegetable food, but its travelling powers cannot be great.

**Cer'berus**, in classical mythology, the dog-monster of Hades, variously described as having a hundred, fifty, and three heads, with a serpent's tail, and a mane consisting of the heads of various snakes. He was subdued by Heracles (Hercules).



Cerberus—antique bronze.

**Cerca'ria**, a name formerly given to a supposed genus of Entozoa, at first mistaken for Infusoria, but now known to be the second larval stage of a trematode worm or fluke. It is a tadpole-like body, which becomes encysted, and gives rise to the sexual forms.

**Cer'cis.** See *Judas Tree*.

**Cercopithe'cus**, a genus of monkeys, one of them being the Diana monkey (*C. Diana*) another the Mona monkey (*C. Mona*).

**Cerdic** (ker'dik), king of the West Saxons, invaded England about the end of the 5th century, and established the kingdom of Wessex about 516. At his death in 534 his kingdom included the present counties of Berks, Wilts, Dorset, and Hants (including the Isle of Wight).

**Cere** (sēr), the naked skin that covers the base of the bill in some birds, and which is supposed to exercise a tactile sense.

**Cerea'lia**, the festival of Ceres, celebrated at Rome.

**Ce'reals**, a term derived from Ceres, the goddess of corn, though sometimes extended to leguminous plants, as beans, lentils, &c., is more usually and properly confined to the Gramineæ, as wheat, barley, rye, oats, and other grasses, cultivated for the sake of their seed as food.

**Cerebra'tion**, exertion or action of the brain, conscious or unconscious.

**Cerebro-spinal**, pertaining to the brain and spinal cord together, looked on as forming one nerve mass.

**Cerebrum** and **Cerebellum.** See *Brain*.

**Cereop'sis**, a genus of birds allied to the geese, the only species being *C. Novæ Hollandiæ*, called New Holland or Australian goose.

**Ceres** (sēr'rēz), a Roman goddess, corresponding to the Greek Dēmētēr; she was the daughter of Kronos and Rhea, and the mother of Proserpine and Bacchus. She was the goddess of the earth in its capacity of bringing forth fruits, especially watching over the growth of grain and other plants. The Romans celebrated in her honour the festival of the Cerealia. Ceres was always represented in full attire, her attributes being ears of corn and poppies, and her sacrifices consisted of pigs and cows.—Also a planet discovered by M. Piazzini at Palermo, in Sicily, in 1801. It was the first discovered of the asteroids. Its size is less than that of the moon.

**Ce'reus**, a genus of cactuses, natives of tropical America, with large funnel-shaped

flowers. Many are night-flowering plants, like *C. grandiflora* of the W. Indies, well known in hothouses.

**Ceria'ma.** See *Seriama*.

**Cerignola** (cher-ē-nyō'là), a town of South Italy, in the province of and 24 miles S.E. from Foggia. It has linen manufactures and a trade in almonds, cotton, &c. Pop. 22,659.

**Cerigo** (cher-ē'gō; anc. *Cythēra*), a Greek island in the Mediterranean, south of the Morea, from which it is separated by a narrow strait; area about 100 sq. miles. It is mountainous and barren, though some of the valleys are fertile, producing corn, wine, and olives. Excellent honey is produced. Sheep, hares, and quails are abundant. Pop. 13,259.—On its west coast is the town of Cerigo; pop. 1200. It is the see of a Greek bishop.

**Cerin'thus**, the founder of a heretical sect of the first century whose doctrines were a mixture of Judaism and Gnosticism, and against whom the Gospel of John was supposed to have been written.

**Ce'rite.** See *Cerium*.

**Cerith'ium**, the typical genus of a family of gasteropodous molluscs, containing numerous species, both marine and fresh-water, and having spiral, elongated, and many-whorled shells.

**Ce'rium**, a rare metal, discovered in 1826, in a Swedish mineral known by the name of *cerite*. It exists also in a few other minerals. It is obtained as a powder in small quantities.

**Ceroplas'tic Art**, the art of modelling in wax.

**Cerox'ylon**, a genus of South American palms; the wax-palm.

**Cerreto** (cher-rā'tō), a town in South Italy, province of Benevento, on the slope of Mount Matese, a pleasant town with a handsome cathedral. Pop. 5343.

**Cerro de Pasco**, a town of Peru, capital of the department of Junin, 14,275 feet above the level of the sea. The town came into existence in 1630, in consequence of the discovery of veins of silver there. The climate is trying and the whole place uninviting, though it still contains the most productive of the Peruvian mines. Pop. about 14,000.

**Certaldo** (cher-tāl'dō), a small town of North Italy, 15 miles S.W. from Florence. It is the birth-place, was long the home, and now contains the ashes of Boccaccio, and many interesting relics.

**Cer'thia**, a genus of insessorial birds, type of the family Certhiadae or Creepers. See *Creepers*.

**Certiora'ri**, in law, a writ issuing out of a superior court to call up the records of an inferior court or remove a cause there depending, that it may be tried in the superior court. This writ is obtained upon the complaint of a party that he has not received justice, or that he cannot have an impartial trial in the inferior court.

**Certosa di Pavia** (cher-tō'sà) a celebrated Italian monastery near Pavia, founded in 1396 by Galeazzo Visconti, duke of Milan. The church is a splendid building.

**Ceru'leum**, a blue pigment, consisting of stannate of protoxide of cobalt mixed with stannic acid and sulphate of lime.

**Ceru'minous Glands**, the glands of the ear which secrete the cerumen or wax which lubricates the passage to the tympanum and prevents the entrance of foreign matter.

**Ceruse** (sē'rus), white-lead, carbonate of lead produced by exposing the metal in thin plates to the vapour of acetic acid or vinegar. It is much used in painting, and a cosmetic is made from it.

**Ce'rusite**, a native carbonate of lead, next to galena the most abundant ore of lead. Its specific gravity is 6.4 to 6.6. When heated it decrepitates, and is converted into oxide of lead.

**Cervantes Saavedra** (ther-vān'tes sà-ā-vā'drà), MIGUEL DE, author of *Don Quixote*, born at Alcalá de Henares in 1547, and removed thence to Madrid at the age of seven. He commenced writing verses at an early age, and his pastoral *Filena* attracted the notice of Cardinal Acquaviva, whom he accompanied to Italy as page. In 1570 he served under Colonna in the war against the Turks and African corsairs, and in the battle of Lepanto (1571) he lost the use of his left hand. After this he joined the troops at Naples, in the service of the Spanish king, winning the highest reputation as a soldier. In 1575, while returning to his country, he was taken by the corsair Arnaut Mami, and sold in Algiers as a slave—a condition in which he remained for seven years, displaying great fortitude. In 1580 his friends and relations at length ransomed him, and, rejoining his old regiment, he fought in the naval battle and subsequent storming of Terceira. In 1583, however, he retired from service, and recommenced his literary work, publishing in 1584 his pastoral *Galatea*.

In the same year he married, and lived for a long time by writing for the stage, to which he contributed between twenty and thirty plays, of which two only have survived. From 1588 to 1599 he lived retired at Seville, where he held a small office. He did not appear again as an author till 1605, when he produced the first part of *Don Quixote*, a work having, as its immediate aim, the satirical treatment of the novels of chivalry then popular, but embodying at the same time human types of cosmopolitan interest, and having a profounder bearing upon life than its express object covered. In 1613 his twelve *Exemplary Novels* (his best work after *Don Quixote*), in 1614 his *Journey to Parnassus*, and in 1615 eight new dramas, with intermezzos, were published. In 1614 an unknown writer published, under the name of Alonzo Fernandez de Avellaneda, a continuation of *Don Quixote*, full of abuse of Cervantes, who thereupon published the real continuation, which was the last work of his issued during his lifetime. His novel *Persiles and Sigismunda* was published after his death, which took place at Madrid on the same day as that of Shakspeare, April 23, 1616.

**Cervetri** (cher-vā'trē), a small place in Italy, prov. Rome, where formerly stood the ancient Etruscan city of *Cære*. It has yielded many artistic and other objects of Etruscan manufacture.

**Cer'vidæ.** See *Cervus*.

**Cervin** (ser-van), MONT (German, *Matterhorn*; Italian, *Monte Silvio*), a mountain, Switzerland, Pennine Alps, on the s. frontiers of canton Valais, about 6 miles w.s.w. Zermatt. It is an almost inaccessible obelisk of rock, starting up from an immense glacier to a height of 14,837 feet. The peak was first ascended by a party of four English travellers and three guides in July, 1865, but three of the party and a guide perished in the descent.

**Cervus**, the genus of animals to which the stag belongs, forming the type of the deer family, *Cervidæ*.

**Cesarotti** (che-sà-rot'tē), MELCHIORE, one of the most celebrated of the Italian literati of the 18th century, born at Padua in 1730, where he became professor of rhetoric, and subsequently professor of the Greek and Hebrew languages. Besides his own poems, his works include translations of Voltaire's tragedies, Ossian, Demosthenes, and the *Iliad*, and essays on the *Philosophy of Languages*, on *Studies*, &c. He died in 1808.

**Cesena** (che-sā'nà), a town of Central Italy, province of Forli, on the right bank of the Savio, at the foot of a mountain. It has a handsome town-house, a cathedral, and some silk-mills. Pop. 11,435.

**Cespedes** (thes'pe-des), PABLO DE, a Spanish painter, sculptor, architect, poet, and man of letters, born at Cordova in 1538, entered the university of Alcalá de Henares in 1556, and finally went to Rome, where he studied under Zucchero and Michael Angelo, and became renowned both for frescoes and sculptures. In 1577 he obtained a prebend in the cathedral of Cordova, and from that time resided alternately in his native town and in Seville. He died in 1608. His best pictures are in Cordova, Seville, Madrid, and several towns of Andalusia. He was the head of the then Andalusian school of painting, and numbered among his pupils some painters of distinction.

**Cessio Bono'rum**, in Scots law, a yielding or surrender of property or goods—a legal proceeding by which a debtor surrenders his whole means and estate to his creditors.

**Cestoi'dea**, CESTOID WORMS, a name for the *Tæniadæ* or tape-worms.

**Cestra'cion**, a genus of cartilaginous fishes allied to the sharks, of which the best-known species is the Port Jackson shark of Australia (*C. Philippi*). The family *Cestracionidæ*, though now poorly represented, was very abundant in the earlier geological periods.

**Cestum Veneris.** See *Girdle of Venus*.

**Cestus**, in classical mythology, a girdle worn by Aphrodītē or Venus, endowed with the power of exciting love towards the wearer.

**Cestus**, a leathern thong or bandage, often covered with knots and loaded with lead and



Various forms of Cestus.

iron, anciently worn by Roman pugilists to increase the force of the blow.

**Ceta'cea**, an order of marine animals, surpassing in size all others in existence. They

are true mammals, since they suckle their young, have warm blood, and respire by means of lungs, for which purpose they come to the surface of the water to take in fresh supplies of air. The body is fish-like in form, but ends in a bilobate tail, which is placed horizontally, not, as in the fishes, vertically. The posterior limbs are wanting, and the anterior are converted into broad paddles or flippers, consisting of a continuous sheath of the thick integument, within which are present representatives of all the bones usually found in the fore-limb of mammals. The fish-like aspect is further increased by the presence of a dorsal fin, but this is a simple fold of integument, and does not contain bony spines. The right whale and its allies have no teeth in the adult state, their place being taken by the triangular plates of *baleen* or whalebone which are developed on transverse ridges of the palate, but the foetal whales possess minute teeth, which are very soon lost. The nostrils open directly upwards on the top of the head, and are closed by valvular folds of integument which are under the control of the animal. When it comes to the surface to breathe it expels the air violently (popularly known as 'blowing' or 'spouting'), and the vapour it contains becomes condensed into a cloud, which resembles a column of water and spray. The blood-vessels in these animals break up into extensive plexuses or net-works, in which a large amount of oxygenated blood is delayed, and they are thus enabled to remain a considerable time under water. Injury to these dilated vessels leads to profuse hemorrhage, and hence the whale is killed by the comparatively trifling wound of the harpoon. The Cetacea (which are grouped broadly as Mysticeti or toothless whales; and Odontoceti, Denticeti, or toothed whales) are commonly divided into five families: (1) *Balenida*, or whalebone whales, divided into two sections: smooth whales, with smooth skin and no dorsal fin, and furrowed whales, with furrowed skin and a dorsal fin; (2) *Physeterida*, *Catodontida*, sperm-whales or cachalots, the palates of which have no baleen-plates, and which are furnished with teeth, developed in the lower jaw only; (3) *Delphinida*, a family possessing teeth in both jaws, and including the dolphins, porpoises, and narwhal; (4) *Rhynchoceti*, a family allied to the sperm-whales, but having only a pair or two pairs of teeth in the lower jaw, a pointed snout or beak, a single blow-hole, &c.; (5) *Zeug-*

*lodontida*, an extinct family, distinguished from all the tooth-bearing whales by the possession of molar teeth implanted by two distinct fangs, &c. The last family is exclusively confined to the Eocene, Miocene, and Pliocene periods. The *Sirenia*, or manatees and dugongs, have sometimes been classified among the Cetacea, but they must be regarded as forming a separate order.

**Ceterach** (set'ér-ak), a genus of ferns, sub-order Polypodiaceæ, chiefly known by the reticulated veins, the simple sori, with scarcely any indusium, and the abundance of chaffy scales which clothe the under surface of the leaf. One species, *C. officinārum* (the scale-fern or miltwaste), is indigenous to Britain, and common on rocks and walls.

**Cetewayo** (kech-wā'ō), a Kaffir chief or king, son of Panda, king of the Zulus. Disturbances as to the succession having arisen in Zululand, Mr. Theophilus Shepstone, representative of the Natal government, secured the recognition of Cetewayo as king in 1873. The latter, however, in spite of the obligations into which he had entered, proved a tyrannical ruler, and maintained a large army. A dispute which had arisen regarding lands on the frontier was settled by arbitration in favour of the Zulus; but on the refusal of Cetewayo to comply with the conditions imposed war was declared against him by the British, and the king made prisoner soon after the battle of Ulundi (July, 1879). In 1882 he was conditionally restored to part of his dominions. In the following year he was driven from power by the chief Usibepu, and remained under the protection of the British until his death in 1884.

**Cetinje.** See *Cettigné*.

**Cetiosau'rus**, CETEOSAURUS, the whale-lizard, a genus of fossil saurians, the most gigantic of the order Deinosauria. The articulations of the bones of the limbs, the possession of long claws, and the hollowness of the bones indicate that it was a terrestrial animal, probably an inhabitant of marshes or river-sides. Their remains are found in the Oolite and Wealden formations.

**Cette** (set), a fortified seaport, France, dep. Hérault, upon a peninsula between the Mediterranean and Lake Thau, into which the great canal of Languedoc enters. After Marseilles, Cette is the principal trading port in the south of France, and it is much resorted to as a watering-place. Pop. 1891, 36,541.

**Cettigné, Cetinje**, &c. (chet-in'ye), the capital of Montenegro, a village in a valley,

containing the residence of the prince, government buildings, &c., about 10 miles inland from the Adriatic. Pop. 2000.

**Cet'yl**, an alcoholic radical supposed to exist in a series of compounds obtained from spermaceti.

**Ceuta** (sū'ta), a strongly-fortified seaport in Marocco, possessed by the Spaniards, on a peninsula of the African coast opposite Gibraltar, the seat of a bishop. Ceuta is used as a place of transportation for criminals. Pop. 9703.

**Cevadil'la.** See *Sabadilla*.

**Cevennes** (sè-venz'; Latin, *Cebennæ*), a chain of mountains in the south-east of France, in the widest sense extending from the Pyrenees in the south-west to the Vosges in the north-east, the Côte d'Or being sometimes considered as a part of it, sometimes as a part of the Vosges system. The length of the chain, exclusive of the Côte d'Or, is about 330 miles, the average height not more than 3000 feet. It is divided into two sections, the Northern and Southern Cevennes; the dividing point is Mount Lozère, in the department of the same name, 5582 feet high. The highest peak is Mezenc, 5753 feet. The Cevennes form the watershed between the Bay of Biscay and the Mediterranean, separating the basins of the Garonne and Loire from those of the Rhone and Saône. They are rich in minerals, containing mines of copper, iron, lead, and coal, and quarries of granite, porphyry, marble, and plaster. The Cevennes were the scene of persecutions of the Albigenses, Waldenses, and others holding opinions opposed to those of the Roman Church.

**Ceylon** (si-lon'; native name *Singhala*, ancient *Taprobñē*), an island belonging to Great Britain in the Indian Ocean, 50 to 60 miles south-east of the southern extremity of Hindustan, from which it is separated by the Gulf of Manaar and Palk's Strait, and by a chain of sand-banks, called Adam's Bridge, impassable by any but very small vessels. Length, about 270 miles north to south; average breadth, 100 miles; area, 24,702 sq. m., or a sixth less than Scotland. The island is pear-shaped—the small end to the north. There are few important indentations. At Trincomalee on the north-east coast, there is one of the finest natural harbours in the world. Point de Galle on the south coast is a regular place of call for the vessels of various lines. A safe and commodious harbour has now been provided for Colombo the capital (on the

west coast). The north and north-west coasts are flat and monotonous, those on the south and east bold, rocky, and picturesque, with exuberant vegetation. The mountainous regions are confined to the centre of the south and broader part of the island. Their average height is about 2000 feet, but several summits are upwards of 7000 and one over 8000 feet high, the culminating point being Pidurutallagalla, 8296 feet. Adam's Peak, reaching 7420 feet, is the most remarkable from its conical form, the distance from which it is visible from the sea, and from the legend that thence Buddha ascended to heaven, leaving in evidence a gigantic footprint. The rivers, though numerous, especially on the south and south-west, are merely mountain streams, navigable only by canoes, and that but for a short distance from their mouths. The most important, the Mahawelli-ganga, which rises near Adam's Peak, and falls into the sea by a number of branches near Trincomalee, has a course of 134 miles, and drains upwards of 4000 square miles. There are a few pretty extensive lagoons in the island yielding large quantities of salt, but no lakes worth noticing.

In respect of climate, it is found that where the jungle has been cleared away, and the land drained and cultivated, the country is perfectly healthy; but where low wooded tracts and flat marshy lands abound it is malarial and insalubrious. The east part of the island being exposed to the north-east monsoon has a hot and dry climate, resembling that of the coast of Coromandel; while the west division, being open to the south-west monsoon, has a temperate and humid climate like that of the Malabar coast. The quantity of rain that falls annually is estimated at three times that of England, the rains being less frequent, but much heavier.

Most of the animals found on the opposite continent are native to this island, excepting the tiger. Elephants are numerous, especially in the north and east provinces, and licenses for their capture and exportation are issued by government. The wild life of the island includes bears, buffaloes, leopards, hyenas, jackals, monkeys, wild hogs, several species of deer, porcupines, armadilloes, mungoes, the pangolin or scaly ant-eater, the loris or Ceylon sloth, flying-foxes, crocodiles, numerous snakes, partly poisonous, and a great variety of birds of brilliant plumage. In the luxuriance of its vegetable produc-

## CEYLON.

tions Ceylon rivals the islands of the Indian Archipelago, and in some respects bears a strong resemblance to them. Its most valuable products are coffee, tea, rice, cinnamon (which is found almost exclusively in the south-west), and the cocoa-nut and Palmyrapalm. Of these coffee is the most extensively cultivated, but disease has within recent years much reduced the produce, and tea cultivation has been taken up in its place, and is rapidly increasing. The south parts of the island produce the jaggery-palm, the sap of which yields a coarse sugar, and its fruit a substitute for rice-flour. The talipot-palm, the jack and bread-fruit trees are abundant, and the Ceylon areca-nut, celebrated for its superior qualities, is exported in large quantities. Excellent tobacco is raised in the north district. The island abounds with timber of various descriptions, including ebony, satin, rose, sapan, iron, jack, and other beautiful woods adapted for cabinet work. Attention has been directed latterly to the cultivation of cinchona, cacao, and silk. The chief mineral products are iron, plumbago or graphite, and a variety of gems, including sapphires, rubies, &c. The pearl-fisheries of Ceylon are famous, but, for some unexplained reason, sometimes fail for years, there having been none between 1837 and 1854, or between 1863 and 1874. When the pearl-fishery is in existence it is confined to the Gulf of Manaar. The fishery is a government monopoly.

The commerce of Ceylon is now important. The total value of exports in recent years has been about £3,500,000 annually (over £2,000,000 to Britain); the value of imports about £4,000,000. The exports comprise coffee, tea, plumbago, areca-nuts, cocoa-nut oil fibre and kernels (copra), cinnamon, cinchona, cacao, &c. The principal articles of import are manufactured goods chiefly from Great Britain, as cotton manufactures, apparel and haberdashery, iron and steel manufactures, machinery, &c.; from other countries dried fish, rice, wheat, sugar, tea, cowries, &c. The island is provided with a system of excellent roads, and the railways have a length of about 200 miles. The chief industry is agriculture; manufactures (coir-matting, baskets, cotton cloth, &c.) are unimportant. The Ceylon currency consists of rupees (present value about 1s. 6d.) and cents. The weights and measures are those of Britain.

Ceylon is one of the British crown colonies, the government being conducted by a

governor and two councils, executive and legislative, of both of which the governor is president. The first is composed of six members, including the governor; the other of fifteen members. The powers of the councils are limited, being wholly subordinate to the governor, who can carry into effect any law without their concurrence. All laws, before being acted on, must be approved of by the secretary of state. Any individual properly qualified may be appointed to the most responsible situation, without reference to service, nation, or religion. The island is divided into eight provinces—the Eastern, Western, Northern, Southern, Central, North-Central, North-Western, and Uva Province, which, again, are subdivided into districts. The chief sources of revenue are the customs duties, railway receipts, land-rents and sales, licenses, and salt-farms. The revenue and expenditure are each usually about £1,000,000. The public debt amounts to £2,300,000; but the finances are in a healthy condition, the debt having been incurred for railways and public works.

The present population of Ceylon is composed of Singhalese or Cingalese, who are the Ceylonese proper, Tamils (from India), Moormen or Moors, Malays, Veddahs, a small proportion of Europeans and their descendants, and negroes. The Singhalese are in stature rather below the middle size; their limbs slender, but well shaped, eyes dark, finely-cut features, hair long, smooth, and black, turned up and fixed with a tortoise-shell comb on the top of the head; colour varying from brown to black, or rather from the lightest to the darkest tints of bronze. The general population of the island was decreasing for several centuries. It is now, however, on the increase, and latterly this increase has been rapid. By census of 1891 the population was 3,008,466, of whom 6068 were British and 21,231 other whites of European descent. The Singhalese numbered 2,041,158, the Tamils 723,853.

Buddhism prevails in the interior, and generally among the Singhalese of the sea-coasts. The Singhalese have a colloquial language peculiar to themselves, but their classic and sacred writings are either in Pali or Sanskrit. The Hindu religion (Brahmanism) prevails among the Tamils or population of Indian extraction, which forms a large proportion of the inhabitants of the north and north-east districts. The Tamils



speak their own Tamil tongue. The government has a department of public instruction, and the total number of scholars in government and other schools is about 120,000. On the west and south-west coast numbers of the Singhalese profess the Roman Catholic religion, and there are various



Singhalese Buddhist Priests and Dagobah at Kandy.

Protestant churches and chapels. The total number of Christians is about 280,000, of whom over 200,000 are R. Catholics.

The Singhalese possess a native chronicle, the *Mahawanso*, which records the history of the island from 543 B.C. onward, under a long series of kings reigning most frequently at the ancient capital Anuradhapura, the earliest of these being leader of an invading host from India. Buddhism was introduced 307 B.C. These incomers brought with them the civilization of India; great part of the country became covered with towns and villages having temples and dagobas, agriculture flourished, and the aborigines (represented by the Veddahs of to-day) were compelled to construct artificial lakes, tanks, and other irrigation works. The capital, Anuradhapura, as its ruins still testify, was a place of great extent and magnificence. The island was not known to Europeans till the time of Alexander the Great, and their knowledge of it was long

vague and meagre. By the time of Pliny it had become better known, and he gained much additional information from Ceylonese envoys that were sent to Rome. In the middle ages the country was much troubled by invasions of the Malabars, and for a time it was even tributary to China. It had greatly declined in prosperity when visited by Europeans, the first of whom was Marco Polo in the end of the 13th century. At its most flourishing period its population was probably ten times as great as at present. Little, however, was known in Europe regarding the island until 1505, when the Portuguese established a regular intercourse with it, and latterly made themselves masters of it. When they arrived the Malabars were in possession of the north, the Moors or Arabs held all the seaports, the rest was under petty kings and chiefs. The Portuguese, who were cruel and oppressive rulers, were subsequently expelled by the Dutch in 1658, after a twenty years' struggle. The Dutch in turn were driven from the island by the British in 1796, though a part of the island remained independent under native princes. The King of Kandy, nominally the sovereign of the island, was deposed in 1815 on account of his cruelties, and the island was then finally annexed by Britain, though a rebellion had to be put down in 1817. The principal towns are Colombo (the capital), Kandy, Point de Galle, Jaffna, and Trincomalee.

**Ceylon Moss**, a name of agar-agar.

**Chablais** (shä-blā), a district of France, in Savoy, south of the Lake of Geneva. In the 11th century Chablais passed from the possession of the house of Burgundy to that of Savoy, and was finally ceded to France with the rest of Savoy in 1860.

**Chablis** (shä-blē), a town, France, dep. Yonne, famous for white wines of a beautifully clear and limpid colour, good body, and extreme delicacy of flavour. Pop. 2185.

**Chabot** (shä-bō), FRANÇOIS, one of the leading Jacobins of the French revolution, was born in 1759. Being chosen deputy to the national convention, he displayed the greatest zeal in the propagation of revolutionary ideas, and in denouncing the court. The conversion of the cathedral of Nôtre Dame into the Temple of Reason is said to have originated with Chabot. He at last became suspected by his party, appealed in vain to Robespierre, and attempted to poison himself, but was guillotined in 1794.

**Chac'ma.** See *Baboon*.

**Chaco.** See *Gran Chaco*.

**Chad.** See *Tchad*.

**Chæronea** (kē-ro-nē'a), an ancient Greek town in Bœotia, famous as the scene of a battle fought B.C. 338, when Philip of Macedon crushed the liberties of Greece.

**Chætodontidæ.** See *Squamipennes*.

**Cha'fer**, a term loosely applied to certain insects of the beetle order, especially such as themselves or their larvæ are injurious to plants.

**Chaff-cutter**, an agricultural instrument for chopping hay or straw into half-inch lengths to be used as food for animals. The economical advantage of the chaff-cutter does not depend on its rendering the chopped food more digestible; but on permitting it to be more thoroughly mixed with the more nutritive and palatable food, and preventing the animal from rejecting any part of it. By the use of the chaff-cutter animals are therefore induced to consume a much larger proportion of fodder with their food, which not only improves the condition of the stock, but saves time in feeding, thus allowing the animal more time for repose.

**Chaff'inch** (*Fringilla caelebs*), a lively and handsome bird of the finch family, very common in Britain, where its haunts are chiefly gardens and shrubberies, hedgerows, plantations, &c. The male is 6 or 7 inches in length, and is very agreeably coloured, having a chestnut back, reddish-pink breast and throat, and a yellowish-white bar on the wings. The food consists of seeds and of insects and their larvæ. The nest, which is generally placed in the fork of a tree, is an elegant structure usually covered with moss and lichens.

**Chagos** (chā'gōs) **Islands**, a group of islands in the Indian Ocean belonging to Britain; a southward extension of the Maldivé Islands. The largest, called Diego Garcia or Great Chagos, 100 miles s. of the main group, is about 15 miles long by 3 broad. They are scantily peopled, and the chief product is cocoa-nut oil.

**Chagres** (chä'gres), a seaport of Colombia, on the N. coast of the Isthmus of Panama, at the mouth of the Chagres river, formerly of some importance.

**Chain**, in surveying, is a measure consisting of 100 links, each 7.92 inches in length, and having a total length of 4 rods, or 66 feet. It is sometimes called Gunter's chain, from its inventor.

**Chain-armour**, coats and other pieces of mail, formed of hammered iron links, con-

stituting a flexible garment which fitted to the person. See *Arms and Armour*.

**Chain-bridge.** See *Bridge*.

**Chain-pump**, a pump consisting in principle of an endless chain equipped with a number of valves or buckets moving round

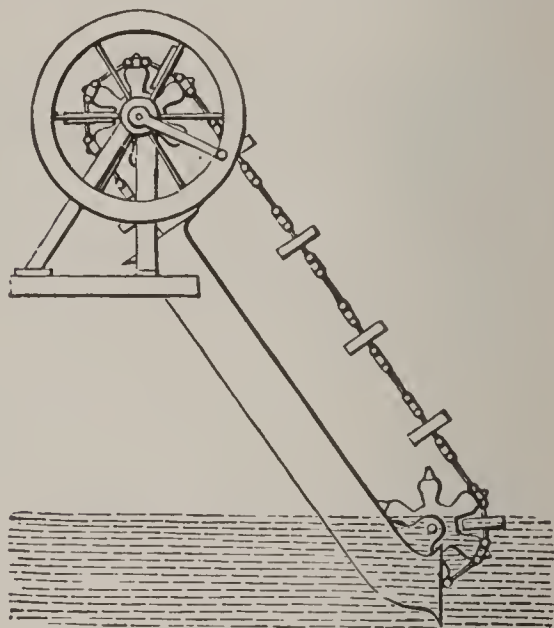

Chain-pump.

two wheels, one above and one below. The chain in its ascent passes through a tube closely fitting the valves or buckets, the water being discharged either from the top of the tube or from an orifice in it.

**Chains**, strong links or plates of iron, the lower ends of which are bolted to a ship's side, used to contain the blocks called *dead-eyes*, by which the shrouds of the masts are fastened.

**Chain-shot**, two cannon-balls connected by a chain, which, when discharged, revolve upon their shorter axis, and mow down masts, rigging, &c.

**Chain-wales.** See *Channels*.

**Chair of St. Peter**, AT ROME, a wooden chair overlaid with ivory work and gold, first mentioned by Ennodius in 500, and in honour of which a feast was instituted by Paul IV. in 1558.

**Chalce'don** (kal-sē'don), a Greek city of ancient Bithynia, opposite Byzantium (Constantinople), at the entrance of the Black Sea, about 2 miles s. of the modern Scutari. It was a flourishing town when it came into possession of the Romans, under the testament of Nicomedes, B.C. 74, as included in the kingdom of Bithynia. It was finally destroyed by the Turks, by whom it was taken about 1075. In ecclesiastical history it is important as the place at which, in 451,

Marcian held the general council for destroying the influence of Dioscurus and the Monophysites by formulating the belief in the existence of two natures in Christ.

**Chalced'ony** (kal-sed'o-ni), a mineral, a variety of quartz, called also white agate, resembling milk diluted with water, semi-transparent or translucent, and more or less clouded with circles and spots. It is found usually in cavities of rocks uncrystallized, in veins, botryoidal masses, &c., and is used in jewelry. There are several varieties, such as the common chalcedony, chrysoprase, sard, and sardonyx.

**Chalcis** (kal'sis), a Greek town, anciently the chief town of Eubœa, separated by the narrow strait of Euripus from the Boeotian coast, on the mainland of Greece, with which it was connected by a bridge. Chalcis, which is mentioned by Homer, early became one of the greatest of the Ionic cities, carrying on an extensive commerce, and planting numerous colonies in Syria, Macedonia, Italy, Sicily, and the islands of the Ægean Sea. It was subsequently a place of importance under the Romans. There is still a town on the site, consisting of an inner walled town and an outer suburb, and said to be one of the prettiest and most attractive of Greek provincial towns. A bridge, so constructed as to let vessels pass through, connects it with the mainland. Pop. 12,250.

**Chalcondylas** (kal-kon'di-las), DEMETRIUS, a Greek grammarian, born at Athens about 1424. On the taking of Constantinople by the Turks he came to Italy, was invited to Florence by Lorenzo de' Medici about 1479, and afterwards by Ludovico Sforza to Milan, where he died in 1510 or 1511. He did much to further the study of the Greek language and literature in the west of Europe.

**Chaldæa**, in ancient geography, the southern part of Babylonia, or in a wider sense corresponding to Babylonia itself. The name Chaldæans was especially applied latterly to a portion of the Babylonian Magi, who were devoted to the pursuit of astronomy and magical science. See *Babylonia*.

**Chaldæan Christians**, a branch of the Nestorians, in communion with the Roman Church.

**Chaldee Language**, a name often given to the Aramean language (or a dialect of it), one of the principal varieties of the ancient Semitic. Chaldee literature is usually arranged in two divisions: the Biblical Chaldee,

or those portions of the Old Testament which are written in Chaldee, namely, Daniel from ii. 4 to vii. 28; Ezra iv. 8 to vi. 18; and vii. 12-26; and Jeremiah x. 11; and the Chaldee of the Targums and other later Jewish writings. See *Aramaic*.

**Chal'der**, an obsolete Scotch dry measure containing 16 bolls or 12 imperial quarters.

**Chal'dron**, an old English measure of 36 bushels, used chiefly in measuring coal.

**Chaleur Bay** (sha-lör'), an inlet of the Gulf of St. Lawrence, between Quebec and New Brunswick. The French fleet was here defeated by the British in 1760.

**Chal'ice**, a term generally applied to a communion cup for the wine in the Eucharist, often of artistic and highly ornamental character.

**Chalk** (çhak), a well-known earthy limestone, of an opaque white colour, soft, and admitting no polish. It is an impure carbonate of lime, and is used as an absorbent and ant-acid, and for making marks for various purposes, as on the black-board in schools, and by artisans and others.—*Black chalk* is a soft variety of argillaceous slate. (See *Black Chalk*.)—*Brown chalk*, a familiar name for umber.—*Red chalk*, another name for ruddle. *French chalk*, steatite or soap-stone, a soft magnesian mineral.—*Drawing chalks* were originally restricted in colours to white, black, and red, but now chalks of every colour are used, and are known by the name of *crayons*.—In geology chalk is the rock which forms the higher part of a series or group of strata, comprising rocks of different kinds, termed the cretaceous system (which see)

**Chal'enge**, to jurors, is an objection either to the whole panel or array, that is, the whole body of jurors returned, or to the *polls*, that is, to the jurors individually; and it is either *peremptory*, that is, without assigning any reason, or *for cause* assigned. See *Jury*.

**Challis** (shal'i), an elegant dress fabric of silk and worsted introduced at Norwich in 1832, soft and pliable and with a cloth surface.

**Chalmers** (çhä'mërz), ALEXANDER, a British journalist, editor, and miscellaneous writer, born at Aberdeen in 1759, where his father, the founder of the first Aberdeen newspaper, was a printer. About 1777 Chalmers came to London, was employed as journalist, and edited the *British Essayist*, from the *Tatler* to the *Observer*, published 1803. He also issued an edition of

## CHALMERS.

Shakspeare, with notes, in 1809; and the works of the English Poets from Chaucer to Cowper, with Johnson's Lives, and additional Lives in 1810. His most extensive work was the General Biographical Dictionary, thirty-two vols., 1812-17. He died in London in 1834.

**Chalmers, GEORGE**, a Scottish antiquary, born in 1742, studied law at Edinburgh, and removed to America, where he practised for upwards of ten years. On his return he was appointed in 1786 clerk to the Board of Trade, an office held by him till his death in 1825. He published various political and statistical works, but latterly turned his attention in a great measure from political science to literature. In 1790 he published his life of Daniel Defoe, and in 1794 his life of Thomas Ruddiman. In 1800 he edited the works of Allan Ramsay; and in 1806 the writings of Sir David Lindsay; but his chief work was his *Caledonia*, of which the first volume was published in 1807, a laborious historical and topographical account of North Britain from the most ancient to recent times. Three volumes were published during Chalmers' lifetime, but he left the remainder of the work nearly ready for the press, and it has recently been published.

**Chalmers, THOMAS, D.D.**, an eminent Scottish divine, born in 1780, at Anstruther Easter, Fife. At the age of twelve he was sent from the parish school to the University of St. Andrews, and after studying there seven years, was licensed as a preacher in July, 1799. During the two following years he studied mathematics and chemistry in Edinburgh, and then became assistant to the professor of mathematics at St. Andrews. In 1803 he was presented to the parish of Kilmany, in Fife, where he made a high reputation as a preacher. In 1804 he was defeated in an application for the chair of natural philosophy at St. Andrews, and again in 1805 for the same chair in Edinburgh University. In 1808 he published an *Inquiry into the Extent and Stability of National Resources*. In 1813 his article on Christianity appeared in the *Edinburgh Encyclopædia*, and shortly afterwards his review of Cuvier's *Theory of the Earth*, in the *Christian Instructor*. His fame as a preacher had by this time extended itself throughout Scotland, and in 1815 he was inducted to the Tron Church of Glasgow. His astronomical discourses delivered there in the following winter produced a sensation not only in the city but throughout the country,

20,000 copies selling in the first year of their publication. It was while pastor of this church that he developed his scheme for the reorganization of the parochial system with a view to more efficient work among the destitute and outcast classes, his influence leading to a considerable extension of the means



Thomas Chalmers, D.D.

of popular instruction, both religious and secular. In 1819 he was transferred from the Tron to St. John's, a church built and endowed expressly for him by the Town Council of Glasgow, but his health having been tried by overwork he accepted, in 1823, the chair of moral philosophy at St. Andrews. In 1827 he was elected to the divinity chair in the University of Edinburgh, an appointment which he continued to hold till the Disruption from the Scottish church in 1843. In 1832 he published his *Political Economy*, and shortly afterwards his *Bridgewater Treatise On the Adaptation of External Nature to the Moral and Intellectual Constitution of Man*. During this period he was occupied with the subject of church extension on the voluntary principle, but it was in the great non-intrusion movement in the Scottish church that his name became most prominent. Throughout the whole contest to the Disruption in 1843, he acted as the leader of the party that then separated from the Establishment, and may be regarded as the founder of the Free Church of Scotland, of the first assembly of which he was moderator. Having vacated his professorial chair in the Edinburgh University, he was appointed principal and primarius professor of divinity in the new college of the Free Church. In addition to his duties in these posts, he continued in

Edinburgh his zealous labours for the elevation of the 'home-heathen,' giving a practical exemplification of his schemes by the establishment of a successful mission in the West Port. His death took place suddenly, and apparently during sleep, in the night preceding May 31st, 1847. He was a D.D. of Glasgow University and a D.C.L. of Oxford.

**Châlon-sur-Saône** (shä-lōŋ-sür sōn), a town of France, dep. Saône-et-Loir, on the right bank of the Saône, which here becomes navigable for steamboats, and at the commencement of the Canal du Centre. It has a cathedral of the 13th century, a fine river quay, an exchange, communal college, &c. There are foundries, dye-works, &c., and a flourishing trade. Pop. 21,159.

**Châlons-sur-Marne** (shä-lōŋ-sür marn), a city of France, capital of the department Marne (Champagne), on the right bank of the river Marne. The principal public buildings are the cathedral, a fine edifice in the Gothic style; three other interesting Gothic churches; the Hotel de Ville, built in 1772; the Hotel de la Prefecture, built in 1764, one of the finest buildings of the kind in France. There are manufactures of woollen and cotton goods; also cotton mills, tanneries, &c. In 451 Attila was defeated before the walls of Châlons, and from the 10th century it flourished as an independent state under counts-bishops, having about 60,000 inhabitants. After being united to the French crown in 1360, it declined. A celebrated camp was established by Napoleon III. about 18 miles from Châlons for the purpose of training the French troops, still to some extent employed. Pop. 17,935.

**Chalybeate Waters** (ka-lib'ē-āt), waters holding iron in solution, either as a carbonate or as a sulphate with or without other salts. All waters containing iron are distinguished by their styptic, inky taste, and by giving a more or less deep colour with an infusion of tea or of nut-galls.

**Chalybite** (kal'i-bīt), an ore of iron, a native anhydrous metacarbonate ( $\text{Fe CO}_3$ ), existing abundantly under the name of *Spathic* or *Sparry Ore*, or *Siderite*. A siliceous or argillaceous variety called clay ironstone, occurring in the coal-measures, is one of the most abundant and valuable ores of iron. Combined with carbonaceous matter it forms the black-band ironstone.

**Chama** (kā'ma), the gaping cockle, a genus of large marine bivalves. The giant clam *Chama gigas* is the largest shell yet

discovered, sometimes measuring four feet across. It is found in the Indian Ocean.

**Chamade** (sha-mād'), a military term for the beat of a drum or sound of a trumpet inviting an enemy to parley.

**Chamærops** (ka-mē'rops), a genus of palms belonging to the northern hemisphere, and consisting of dwarf trees with fan-shaped leaves borne on prickly petioles, and a small berry-like fruit with one seed. The *C. humilis* is the only native European palm. It does not extend further north than Nice. The fibres of its leaves form an article of commerce under the name of *crin végétal* (vegetable hair). Brazilian grass is a fibre obtained from the *Chamærops argentea*. A Chinese species, *C. Fortunei*, is quite hardy in the south of England.

**Cham'alari**, CHAM'ALHARI, a peak of the Himálaya Mountains, at the western extremity of the boundary line between Bhutan and Tibet. Height, 23,929 feet.

**Chamber**, a word used in many countries to designate a branch of government whose members assemble in a common apartment, as the *chamber* of deputies in France, or applied to bodies of various kinds meeting for various purposes. The *imperial chamber* (in German *Reichskammergericht*) of the old German Empire was a court established at Wetzlar, near the Rhine, by Maximilian I. in 1495, to adjust the disputes between the different independent members of the German Empire, and also such as arose between them and the emperor.—*Chambers of commerce* are associations of the mercantile men of towns for the purpose of protecting and furthering the interests of the commercial community.

**Chamberlain** (chām'bér-lin), an officer charged with the direction and management of the private apartments of a monarch or nobleman. The *lord-chamberlain* or *lord-great-chamberlain* of Great Britain is the sixth officer of the crown. His functions, always important, have varied in different reigns. Among them are the dressing and attending on the king at his coronation; the care of the palace of Westminster (Houses of Parliament); and attending upon peers at their creation, &c. The office of *lord-chamberlain of the household* is quite distinct from that of the great-chamberlain, and is changed with the administration. This officer has the control of all parts of the household (except the ladies of the queen's bed-chamber) which are not under the direction of the lord-steward, the groom of the stole, or

the master of the horse. The king's (queen's) chaplains, physicians, surgeons, &c., as well as the royal tradesmen, are by his appointment; the companies of actors at the royal theatres are under his regulation; and he is also the licenser of plays.

**Chamberlain**, JOSEPH, English statesman, born in London in 1836, and educated at London University school. He became a member of a firm of screw-makers at Birmingham, but gave up active connection with the business in 1874. He early became prominent in Birmingham both in connection with civic and political affairs, being an advanced radical and an able speaker, was chairman of the school-board, and thrice in succession mayor of the city (1874-76). In 1876 he entered parliament as a representative of Birmingham, and at the general election of 1880 he was chosen for the same city along with Mr. Bright and Mr. Muntz. Under Mr. Gladstone's premiership he now became president of the Board of Trade, and a cabinet-minister, and was able to pass the Bankruptcy Act now in force, though he failed with his merchant shipping bill. In the Gladstone government of 1886 he was president of the Local Government Board; but his leader's Irish policy caused him to resign, and since then, as member for West Birmingham, he has been one of the most pronounced members of the Liberal-Unionist party. In the winter of 1887-88 he was in America as one of the British representatives appointed to negotiate a settlement of the fishery disputes between Canada and the U. States, but the treaty which resulted has not yet been ratified. He is Secretary of the Colonies and a member of the cabinet.

**Chambers** (chām'bérz), EPHRAIM, a miscellaneous writer, and compiler of a popular Dictionary of Arts and Sciences, born at Kendal, in Westmoreland, in the latter part of the 17th century. During his apprenticeship to a mathematical instrument and globe-maker in London he formed the design of compiling a Cyclopædia, and even wrote some of the articles for it behind his master's counter. The first edition was published in 1728. Several subsequent editions appeared previously to his death in 1740, and it was the basis of the cyclopædia of Dr. Abraham Rees.

**Chambers**, ROBERT, historical and miscellaneous writer, the younger of two brothers originally composing the publishing firm of W. & R. Chambers, was born at Peebles in 1802, his father being a muslin

weaver. Along with his brother William who was his senior by two years, he received his education at the Peebles parish school and in the High School of Edinburgh. His family experiencing a reverse of fortune, he got together all the books belonging to his mother and himself, their value being about £2, and at the age of sixteen commenced business as a bookseller in Edinburgh. His elder brother William established himself in the neighbourhood as a printer, and they united in projecting and issuing a short-lived periodical called the Kaleidoscope, Robert being editor and chief contributor, and William printer. Robert's Illustrations of the Author of Waverley and his Traditions of Edinburgh (1823) won a ready popularity, and various other works followed in quick succession from this period till 1832:—Popular Rhymes of Scotland (1826); Picture of Scotland (1827); Histories of the Scottish Rebellions; and a Life of James I. He next edited Scottish Ballads and Songs; a Biographical Dictionary of Eminent Scotsmen; and on the 4th of February, 1832, the brothers commenced Chambers's Edinburgh Journal, which achieved an immense success. From this time W. & R. Chambers united in the publishing business, and issued a series of works for the entertainment and instruction of 'the people.' Robert Chambers contributed numerous essays to the Journal, besides editing or compiling many instructive works of a high class, including the Cyclopædia of English Literature; the Domestic Annals of Scotland; Ancient Sea-Margins; and the Book of Days. He also edited a valuable edition of Burns. He died at St. Andrews in 1871. His name was long associated with the authorship of the famous 'Vestiges of Creation,' and it was not known to be really his till years after his death.—WILLIAM CHAMBERS wrote Things as they are in America, History of Peebles-shire; France, its History and Revolutions; Memoir of Robert Chambers, with autobiographical Reminiscences, &c. He was twice lord-provost of Edinburgh, and latterly bore the expense of restoring the old church of St. Giles's, Edinburgh. He also presented the town of Peebles with an institution embracing a library, reading-room, museum, &c. He died in 1883, just as a baronetcy was to be conferred on him.

**Chambersburg**, a town, United States, Pennsylvania, in a fertile and populous district. Pop. 1890, 7863.

**Chambertin** (shän-ber-tan), a superior kind of red Burgundy wine, named after the place where it is produced.

**Chambéry** (shän-bä-ri), a town of S.E. France, capital of department Savoie. It is an archbishop's see, and contains a cathedral, a castle, now the prefecture, the palace of justice, barracks, &c. The old ramparts have been converted into public walks. In its vicinity are excellent baths, much frequented in summer. It has manufactures and distilleries. Pop. 14,698.

**Chambord** (shän-bör), a castle, park, and village, near Blois, department of Loir-et-Cher, in France. The splendid castle, in the Renaissance style, was mainly built by Francis I., being begun in 1526, and was completed under Louis XIV. In 1745 it was given by Louis XV. to Marshal Saxe, who died there in 1750. Napoleon gave it to Berthier, and in 1821 a company of Legitimists bought it and gave it to the Duke of Bordeaux (see next art.) in name of the people of France.

**Chambord** (shän-bör), HENRI CHARLES FERDINAND MARIE DIEUDONNÉ, Comte de, Duke of Bordeaux, the last representative of the elder branch of the French Bourbon dynasty, called by his partisans Henry V. of France. He was born in 1820, seven months after the assassination of his father, Prince Charles Ferdinand d'Artois duke de Berry. Charles X., after the revolutionary outbreak of 1830, abdicated in his favour; but the young count was compelled to leave the country with the royal title unrecognized by the nation. He lived successively in Scotland, Austria, Italy, and London, keeping a species of court, and occasionally issuing manifestoes. In 1846 he married the Princess Maria-Theresa, eldest daughter of the Duke of Modena; and in 1851 inherited the domain of Frohsdorf, near Vienna, where for the most part he subsequently resided. While abstaining from violent attempts to seize the crown, he let slip no opportunity of urging his claims, especially after Sedan; but his belief in divine right, his devotion to the see of Rome, and his failure to recognize accomplished facts and modern tendencies, destroyed all chance of his succession. He died in 1883, leaving no heir.

**Chambre Ardente** (shän-br-är-dänt; *fiery chamber*), the name formerly given in France to an apartment, hung with black and lighted with tapers, in which sentence of death was pronounced on heinous offenders. The name was afterwards more especially

given to those extraordinary tribunals which, from the time of Francis I., ferretted out heretics by means of a system of espionage, directed the proceedings against them, pronounced sentence, and also saw it carried into execution.

**Chame'leon** (ka-mē'li-on), a genus of reptiles belonging to the Saurian or lizard order, a native of parts of Asia, Africa, and the south of Europe. The best-known species, *Chameleo africanus* or *C. vulgaris*, has a

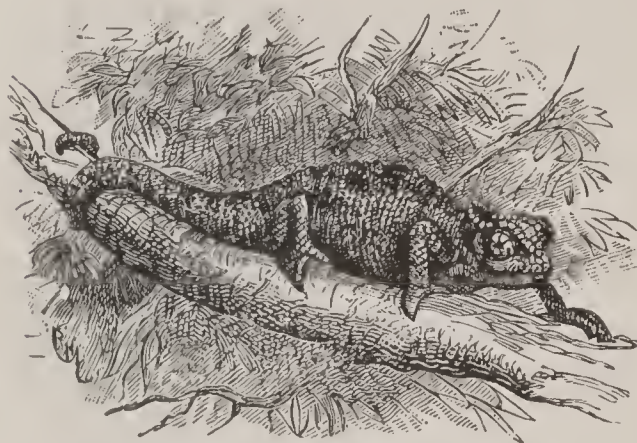

Chameleon (*Chameleo africanus*).

naked body 6 or 7 inches long, with a prehensile tail of about 5 inches, and feet suitable for grasping branches. The skin is cold to the touch, and contains small grains or eminences of a bluish-gray colour in the shade, but in the light of the sun all parts of the body become of a grayish-brown or tawny colour. It possesses the curious faculty, however, of changing its colour, either in accordance with its environment, or with its temper when disturbed, the change being due to the presence of clear or pigment-bearing contractile cells placed at various depths in the skin, their contractions and dilatations being under the influence of the nervous system. Their power of fasting and habit of inflating themselves gave rise to the fable that they lived on air, but they are in reality insectivorous, taking their prey by rapid movements of a long viscid tongue. In general habit they are dull and torpid.

**Chameleon Mineral**, a name given to manganate of potassium, because a solution of it changes from green, through a succession of colours, to a rich purple.

**Chamfort** (shän-för), SEBASTIEN-ROCH NICOLAS, a French man of letters, wit, and revolutionist, born in 1741. By his success as dramatist, critic, and conversationalist he obtained a place in the French Academy, a pension, and a post at court. An inti-

mate friend of Mirabeau, he threw himself heartily into the revolution, was secretary to the club of the Jacobins, was one of the first of the storming party in the attack on the Bastille, and having been employed by Roland in the *Bibliothèque Nationale* published the first twenty-six *Tableaux Historiques de la Révolution*. His cynical wit could not, however, restrain itself, and he was denounced and threatened with imprisonment. Rather than undergo it he inflicted fatal injuries upon himself, dying in 1794. He is seen at his best in the collection of *bon mots* published under the title of *Chamfortiana*.

**Chamier** (sham'i-ér), FREDERICK, an English writer of fiction, born in 1796, died in 1870. He entered the navy, took part in the last campaigns against the French, and distinguished himself in the American war of 1812. He retired in 1833, with the rank of captain. His principal works are, *The Life of a Sailor*; *Ben Brace*; *The Arethusa*; *Jack Adams*; *Tom Bowline*.

**Chamisso** (shā-mis'ō), ADELBERT DE, German poet, French by birth, born at the castle of Boncourt, in Champagne, in 1781, His family being driven to Berlin by the revolution, he became, from 1796 to 1798, page to the queen-mother, and afterwards entered the Prussian service, where he remained till 1808. He then revisited France; but shortly after returned to Prussia, and for three years devoted himself to the study of natural science at Berlin. In 1815 he accompanied as naturalist an expedition for the discovery of the north-west passage, and on his return took up his residence at Berlin, where he was appointed superintendent of the botanic garden. He died at Berlin in 1838. He wrote several works on natural history and botany, and an account of his voyage, but his reputation as a naturalist has been somewhat eclipsed by that which he acquired as a poet. In 1804-6, in concert with Varnhagen von Ense, he published a collection of poems, under the name of the *Muses' Almanac*; and in 1813 appeared his famous tale, *Peter Schlemihl*, or the *Shadowless Man*, the plot suggested by a casual question of Fouqué's. Many of his ballads and songs are masterpieces in their way and still maintain their popularity.

**Chamois** (sham'wä; *Antilope rupicapra*), a species of goat-like antelope inhabiting high inaccessible mountains in Europe and Western Asia. Its horns, which are about

6 or 7 inches long, are round, almost smooth, perpendicular and straight until near the tip, where they suddenly terminate in a hook directed backwards and downwards. Its hair is brown in winter, brown fawn



Chamois (*Antilope rupicapra*).

colour in summer, and grayish in spring. The head is of a pale yellow colour with a black band from the nose to the ears and surrounding the eyes. The tail is black. Its agility, the nature of its haunts, and its powers of smell, render its pursuit an exceedingly difficult and hazardous occupation.

**Chamomile** or CAMOMILE (kam'o-mil; *Anthēmis nobilis*), a well-known plant belonging to the natural order Compositæ. It is perennial, and has slender, trailing, hairy, and branched stems. The flower is white, with a yellow centre. Both leaves and flowers are bitter and aromatic. The fragrance is due to the presence of an essential oil, called oil of chamomile, of a light blue colour when first extracted, and used in the preparation of certain medicines. Both the leaves and the flowers are employed in fomentations and poultices, and also in the form of an infusion as a stimulant or anti-spasmodic. It is cultivated in gardens in the United States, and also found wild. —Wild chamomile (*Matricaria chamo-*



*millu*) is now out of use in England; but its medicinal properties resemble those of common chamomile, and it is still used in some parts of Europe.

**Chamond** (chä-mōn), St., a manufacturing town of France, department Loire, on the railway from St. Étienne to Lyons. It is well built, has an old castle and a handsome parish church; and has silk factories, large iron-foundries, dye-works, &c. Pop. 14,149.

**Chamouni** (shä-mö-nē), or CHAMONIX (shä-mo-nē), a celebrated valley in France, department Haute-Savoie, in the Pennine Alps, over 3000 feet above sea-level. It is about 12 miles long, by 1 to 6 miles broad, its E. side formed by Mont Blanc and other lofty mountains of the same range, and it is traversed by the Arve. The mountains on the E. side are always snow-clad, and from these proceed numerous glaciers, such as the Glacier de Bossons and the Mer de Glace. The village of Chamouni (pop. 1500) is much frequented by tourists, and is one of the points from which they visit Mont Blanc.

**Champac.** See *Champak*.

**Champagne** (shän-pāny), an ancient province of France, which before the revolution formed one of the twelve great military governments of the kingdom. It forms at present the departments of Marne, Haute-Marne, Aube, Ardennes, and part of those of Yonne, Aisne, Seine-et-Marne, and Meuse. Troyes was the capital.

**Champagne** (sham-pān'), a French wine, white or red, which is made chiefly in the department of Marne, in the former province Champagne, and is generally characterized by the property of creaming, frothing, or effervescing when poured from the bottle, though there are also *still* Champagne wines. The creaming or slightly sparkling Champagne wines are more highly valued by connoisseurs, and fetch greater prices than the full-frothing wines, in which the small quantity of alcohol they contain escapes from the froth as it rises to the surface, carrying with it the aroma and leaving the liquor nearly vapid. The property of creaming or frothing possessed by these wines is due to the fact that they are partly fermented in the bottle, carbonic acid being thereby produced. Wine of a similar kind can of course be made elsewhere, and some of the German champagnes are hardly to be distinguished from the French. Much artificial or imitation champagne is sold.

**Champaign**, Ills., a city 128 miles S. W. from Chicago. Seat of the State Industrial University; contains a park of 10 acres, connected by street cars with *Urbana*, the county-seat, 2 miles distant (a town of about 5000). C. has a fine public library, 4 banks, and 3 factories. Pop. 1890, 5809.

**Cham'party**, or CHAMPERTY (L. *campi partitio*, a dividing of land), in *law* is a bargain with the plaintiff or defendant in any suit to have part of the land, debt, or other thing sued for, if the party that undertakes it prevails therein; the champertor meanwhile furnishing means to carry on the suit. Such bargains are illegal. See *Maintenance*.

**Champ-de-Mars** (shän-dè-märs), that is Field of Mars, an extensive piece of ground in Paris, used as a place of military exercise. It was here that Louis XVI. swore to defend the new constitution in 1790, and it was the site of the exhibitions of 1867 and 1878.

**Champignon** (sham-pin'yon), a name given to the common mushroom (*Agaricus campestris*).

**Cham'pion of the king**, a person whose office it was at the coronation of English monarchs to ride armed into Westminster Hall, and make challenge that if any man should deny the king's title to the crown he was ready to defend it in single combat.

**Champlain** (sham-plān') LAKE, a lake, chiefly in the United States, between the states of New York and Vermont, but having the north end of it in Canada; extreme length, north to south, about 120 miles; breadth, from half a mile to 15 miles; area, about 600 square miles. It is connected by canal with the Hudson River, and has for outlet the river Richelieu, or Sorel, flowing north to the St. Lawrence. Its scenery is beautiful, and attracts many visitors.

**Champlain** (shän-plān), SAMUEL, a French naval officer and maritime explorer, born about 1570. His exploits in the maritime war against Spain in 1595 attracted the attention of Henry IV., who commissioned him in 1603 to found establishments in North America. After three voyages for that purpose, in the last of which he founded Quebec, he was in 1620 appointed governor of Canada. He wrote an account of his voyages, and died in 1635.

**Champollion** (shän-pol-yōn), JEAN FRANÇOIS, French scholar, celebrated for his discoveries in the department of Egyptian hieroglyphics, born at Figeac, department of Lot, in 1790. At an early age he devoted

himself to the study of Hebrew, Arabic, Coptic, &c., and in 1809 became professor of history at Grenoble. He soon, however, retired to Paris, where, with the aid of the trilingual inscription of the Rosetta Stone and the suggestions thrown out by Dr. Thomas Young, he at length discovered the key to the graphic system of the Egyptians, the three elements of which—figurative, ideographic, and alphabetic—he expounded before the Institute in a series of memoirs in 1823. These were published in 1824 at the expense of the state, under the title of *Précis du Système Hiéroglyphique des Anciens Égyptiens*. In 1826 Charles X. appointed him to superintend the department of Egyptian antiquities in the Louvre; in 1828 he went as director of a scientific expedition to Egypt; and in 1831 the chair of Egyptian archæology was created for him in the Collège de France. He died at Paris in 1832. Other works are his *Grammaire Égyptienne*, and *Dictionnaire Hiéroglyphique*.

**Champollion-Figeac** (shän-pol-yōn-fē-zhāk), JACQUES JOSEPH, the elder brother of the preceding, born at Figeac in 1778, died in 1867. His principal works are: *Antiquités de Grenoble*, 1807; *Paléographie Universelle*; *Annales des Lagides*, 1819; *Traité élémentaire d'Archéologie*, 1843; *Écriture démotique Égyptienne*, 1843; *L'Égypte Ancienne*, 1850.

**Chance.** See *Probability*.

**Chan'cel** is that part of the choir of a church, between the altar or communion-table and the rail that incloses it.

**Chan'cellor**, a high official in many of the kingdoms of Europe, the office including in its duties the supervision of charters and other official writings of the crown requiring solemn authentication. The title and office are also ecclesiastical, and hence each bishop still has his chancellor, the principal judge of his consistory. In the new German empire, the chancellor (*Reichskanzler*) is president of the Federal Council, and has the general conduct of the imperial administration. In the United States, a chancellor is the judge of a court of chancery or equity established by statute.

The *Lord High-chancellor* of Great Britain and Ireland (originally of England), who is also Keeper of the Great Seal, is the first judicial officer of the crown, and exercises an extensive jurisdiction as head of the Supreme Court of Judicature. He ranks as first lay person of the state after

the blood-royal. He is a cabinet minister and a privy-councillor in virtue of his office, is prolocutor of the House of Lords by prescription, and vacates his office with the ministry which appoints him. He has a salary of £10,000. He has the appointment of all justices of the peace, is visitor, in the king's right, of all royal foundations, keeper of the king's conscience, guardian of all charitable uses, and judge of the high court of chancery. There is also a Lord Chancellor of Ireland, who is the head of the judicial bench, with a salary of £8000. He is not a member of the British ministry. The chancellorship of Scotland was abolished at the union.

The *Chancellor of the Exchequer* is the principal finance minister of the British government, and as all questions of supply originate in the House of Commons, a peer cannot be conveniently appointed to this office. It is sometimes held along with that of first lord of the treasury. The judicial functions formerly exercised by the chancellor in the court of exchequer are now obsolete.

The *Chancellor of the Duchy of Lancaster* presides in the court of the duchy chamber, to decide questions relating to lands held of the king as Duke of Lancaster.

The *Chancellor of the order of the Garter* and other military orders is an officer who seals the commissions and the mandates of the chapter and assembly of the knights of the order, keeps the register of their proceedings, and delivers their acts under the seal of their order.

*Chancellor of a university*, the highest honorary official in the university, from whom the degrees are regarded as proceeding. The post in Britain is usually occupied by a person of rank.

**Chan'cellorsville**, the site of one of the greatest battles of the American civil war, in which, on the 2d, 3d, and 4th of May, 1863, a nominal victory was gained by the Confederates under Generals Lee and Jackson over the Federal troops commanded by General Hooker. The Federal troops, though compelled to retreat across the Rappahannock, carried with them some thousands of prisoners and one more gun than they had lost, while the Confederates lost from 15,000 to 18,000 men and their brilliant leader Jackson.

**Chance-medley**, in law, homicide happening either in self-defence, on a sudden quarrel, or in the commission of an unlaw-

ful act without any deliberate intention of doing mischief.

**Chan'cery**, formerly the highest court of justice in England next to parliament, but since 1873 a division of the High Court of Justice, which is itself one of the two departments of the Supreme Court of Judicature (which see). Formerly it embraced six superior courts called high courts of chancery, viz.: the court of the lord high-chancellor, the court of the master of the rolls, the court of appeal in chancery, and the courts of the three vice-chancellors, with various inferior courts. The jurisdiction of the court was both ordinary and extraordinary, the former as a court of common law, the latter a court of equity. The extraordinary court, or court of equity, proceeded upon rules of equity and conscience, moderating the rigour of the common law, and giving relief in cases where there was no remedy in the common law courts. The Chancery Division now consists of the lord-chancellor as president and five justices. In American law a court of general equity jurisdiction. Separate courts of chancery or equity exist in some of the States; in others the courts of law sit also as courts of equity; in others the distinction between law and equity has been abolished or never existed.

**Chanda** (chân-dä'), a town of India, Central Provinces, surrounded by a wall  $5\frac{1}{2}$  miles long, with manufactures and a considerable trade. Pop. 16,137. — The DISTRICT has an area of 10,785 sq. miles, a pop. of 649,146.

**Chandausi** (chan-dou-sē'), a town of India, N.W. Provinces, Moradabad district. Pop. 27,521.

**Chanderi** (chan-dā'rē), or CHANDHAIREE, a town in Central India, Scindia's Dominions, in a hilly and jungly tract, 103 miles s. of Gwalior, formerly of considerable extent and splendour, but now an insignificant place. There is a fort which figures much in the wars of the Mogul dynasty.

**Chan'dernagore**, or CHAN'DARNAGAR ('city of sandalwood'), a town in Hindustan, belonging to France, on the right bank of the Hooghly, 16 miles N.N.W. of Calcutta. The French established a factory in it in 1676, and in 1688 obtained a formal cession of it, together with its territory of 2325 square acres, from Aurungzebe. It was three times occupied by the British, but was finally restored to the French in 1816. Pop. of town and territory, 26,718.

**Chandpur'**, town of India, Bijnaur district, N.W. Provinces; thriving, well paved and drained. Pop. 11,182.

**Chang-Chow-Foo**, a city, China, province of Fokien, 36 miles s.w. of Amoy, which is its port. It stands in a valley surrounded by hills and intersected by a river, and is the centre of the silk manufacture of the province. Pop. estimated at from 800,000 to 1,000,000.

**Chank-shell**, the common conch-shell (*Turbinella pyrum*), of a spiral form, worn as an ornament by the Hindu women. A shell with its spires or whorls turning to the right is held in peculiar estimation and fetches a high price. The chank is one of the gasteropodous mollusca.

**Channel**, ENGLISH. See *English Channel*.

**Channel Islands**, a group of islands in the English Channel, off the w. coast of department La Manche, in France. They belong to Britain, and consist of Jersey, Guernsey, Alderney, and Sark, with some dependent islets. They are almost exempt from taxation, and their inhabitants enjoy besides all the privileges of British subjects. The government is in the hands of bodies called the 'states,' some members of which are named by the crown, while others are chosen by the people, and others sit *ex officio*. The islands have been fortified at great expense. They form the only remains of the Norman provinces once subject to England. Area 112 sq. miles, pop. 88,289. See the separate articles.

**Channels**, or CHAIN-WALES, of a ship, broad and thick planks projecting horizontally from the ship's outside, abreast of the masts. They are meant to keep the shrouds clear of the gunwale.

**Channel Tunnel**. See *English Channel*.

**Channing** (chan'ing), WILLIAM ELLERY, American preacher and writer, born at Newport, Rhode Island, in 1780. He studied at Harvard College, became a decided Unitarian, and propagated Unitarian tenets with great zeal and success. His first appointment as a pastor was in 1803, when he obtained the charge of a congregation in Boston, and ere long he became known as one of the most popular preachers of America. His reputation was still further increased by the publication of writings, chiefly sermons, reviews, &c., on popular subjects. He died at Burlington, Vermont, in 1842.—His nephew, WILLIAM HENRY CHANNING, born 1810, also a Unitarian preacher (for some time at Liverpool) and supporter of the

socialistic movement, has written a memoir of his uncle and other works. Died in 1884.

**Chant**, a short musical composition consisting generally of a long reciting note, on which an indefinite number of words may be intoned, and a melodic phrase or cadence. A single chant consists of two strains, the first of three and the second of four bars in length. A double chant has the length of two single ones.

**Chanterelle** (shan-tér-el'), a British edible mushroom (*Cantharellus cibarius*) of a bright orange colour, with a pleasant fruity smell.

**Chantilly** (shàn-tē-yē), a town, France, department of the Oise, 25 miles N.N.E. of Paris, celebrated for a variety of lace made here and in the neighbourhood; for the splendid château, built by the great Condé, but levelled by the mob at the revolution; and also for another palace built by the Duc d'Aumale after the estate came into his possession in 1850, which, along with the fine domain, was presented by the duke to the French Institute in 1887. It is a horse-racing centre. Pop. 4000.

**Chant'rey**, SIR FRANCIS, an English sculptor, born in 1781 near Sheffield, was the son of a well-to-do carpenter. Even in boyhood his chief amusement was in drawing and modelling figures, and he was apprenticed in 1797 to a carver and gilder. In 1802 he commenced work for himself at Sheffield by taking portraits in crayons. After studying at the Royal Academy in London he eventually settled in the metropolis, where he presented numerous busts at the exhibitions of the Royal Academy. One of these, in 1811, attracted the admiration of Nollekens, who had the generosity to exclaim, 'There's a fine, a very fine busto; let the man who made it be known; remove one of my busts and put this one in its place, for it well deserves it.' This was the commencement of his career of fame and fortune, and he soon came to be regarded as the first monumental sculptor of his time. In 1816 he was chosen an associate and in 1818 a member of the Royal Academy. He was knighted in 1835, and died in 1842. His most celebrated works are the Sleeping Children, in Lichfield Cathedral; the statue of Lady Louisa Russell, in Woburn Abbey; the bronze statue of William Pitt, in Hanover Square, London; a statue of Washington, in the States House, Boston; and statues of Horner, Canning, Sir J. Malcolm, &c., in Westminster Abbey. His best works are his busts, but his full-length figures betray

an insufficient acquaintance with anatomy, and several of his equestrian statues are still more defective.

**Chant'ry**, an endowment to provide for the singing of masses; also the chapel where the masses are chanted. Chantry chapels were frequently endowed by the will of the founders in order to have mass sung for the repose of their souls.

**Chao-Chow**, a city, China, province Quang-tung, on the river Han, 195 miles N.E. of Hong-Kong, the centre of an important maritime division of the province.

**Chaos** (kā'os), in old theories of the earth, the void out of which sprang all things or in which they existed in a confused, unformed shape before they were separated into kinds.

**Chapala** (chà-pä'lá), a picturesque lake of Mexico, states of Xalisco and Michoacan. Area, 1400 square miles.

**Chap-books**, a species of cheap literature which preceded the popular periodicals of the present day. They usually consisted of coarsely printed (and often coarsely written) publications sold for a copper or two, and were so called because they were prepared by the popular publishers expressly for sale by the chapmen or pedlars, who hawked them from district to district. They included lives of heroes and wonderful personages, tales of roguery and broad humour, witch and ghost stories, &c.

**Chap'el**, a term applied to buildings of various kinds erected for some sort of religious service. Thus it may mean a subordinate place of worship attached to a large church, and especially to a cathedral, separately dedicated and devoted to special services. (See *Cathedral*.) Or it may mean a building subsidiary to a parish church and intended to accommodate persons residing at a distance from the latter; or a place of worship connected with a palace, castle, university, &c.

**Chaplain** (chap'lin), literally a person who is appointed to a chapel, as a clergyman not having a parish or similar charge, but connected with a court, the household of a nobleman, an army, a prison, a ship, or the like. Chaplains in the United States service have the assimilated rank of captain. They receive a yearly pay of \$1500.

**Chaplain-general**, the head of the chaplains attached to the staff of the British army. He assists the war-office in selecting the chaplains and regulating their duties. He has a salary of £1000 a year.

**Chaplet**, a string of beads used by Roman Catholics to count the number of their prayers. In heraldry it means a garland of leaves, with four flowers amongst them at equal distances; in architecture, a small moulding carved into beads, pearls, &c.

**Chapman**, in general a merchant or trader, but in modern times more specifically a hawker or one who has a travelling booth.

**Chapman**, GEORGE, an English poet, the earliest, and perhaps the best, translator of Homer, was born in 1557, and died in 1634. He was educated at Oxford, and in 1576 proceeded to London; but little is known of his personal history. His translation of the Iliad was published in three separate portions in 1598, 1600, and 1603. It has been highly commended by such poets as Pope, Keats, and Coleridge, as also by Lamb. Keats's sonnet, *On First Looking into Chapman's Homer* ('Then felt I like some watcher of the skies,' &c.), is well known. In 1614 appeared his translation of the Odyssey, followed in the same year by that of the *Battle of the Frogs and Mice* and the *Homerichymns*. He also translated Hesiod's *Works and Days* and portions of various classic poets. He wrote numerous plays, almost all now forgotten, though containing some fine passages.

**Chapoo**, a seaport, China, province Chekiang, on the N. side of a large bay, 35 miles N. from Ningpo. It carries on a considerable trade with Japan.

**Chapra** (*chap-rä'*). See *Chuprah*.

**Chaptal** (*shap-täl*), JEAN ANTOINE CLAUDE, Count de Chanteloup, peer of France, was born in 1756, and devoted himself to the study of medicine and the natural sciences, and especially chemistry. He supported the revolution, and was appointed in 1799 counsellor of state, and in 1800 minister of the interior, in which post he encouraged the study of the arts and established a chemical manufactory in the neighbourhood of Paris. In 1805 he was made a member of the senate. On the restoration he was obliged to retire to private life, but in 1816 the king nominated him a member of the Academy of Sciences, and latterly made him a peer. Chaptal's works on national industry, chemistry, the cultivation of the vine, &c., were very much esteemed, especially his *Chimie Appliquée aux Arts* (Paris, 1807, four vols.), his *Chimie Appliquée à l'Agriculture* (Paris, 1823, two vols.), and *De l'Industrie Française* (Paris, 1819, two vols.).

**Chapter**, one of the chief divisions of a book. As the rules and statutes of ecclesiastical establishments were arranged in chapters, so also the assembly of the members of a religious order, and of canons, was called a *chapter*. The orders of knights used this expression for the meetings of their members, and some societies and corporations call their assemblies *chapters*.

**Chapter-house**, the building attached to a cathedral or religious house in which the chapter meets for the transaction of business. They are of different forms, but are often polygonal in plan. Sometimes they were the burying-place of clerical dignitaries. See *Cathedral*.

**Char**, or CHARR (*Salmo umbla*), a European fresh-water fish of the salmon genus, found plentifully in the deeper lakes of England, Wales, and Ireland, more rarely in those of Scotland. The chars inhabit the colder regions of deep waters, where the temperature is less liable to vary. The body somewhat resembles that of a trout, but is longer and more slender, as well as more brilliant in colouring, with crimson, rose, and white spots; weight sometimes 2 lbs., but generally under 1 lb. Char is much esteemed for the table.

**Chara'ceæ** (*ka-*), an order of cryptogamous plants, nearly related to the Algæ, composed of an axis consisting of parallel tubes, which are either transparent or incrustated with carbonate of lime, inhabiting stagnant water, both fresh and salt, beneath which they are always submersed. They are most common in the temperate zone, and emit an unhealthy fetid odour.

**Charade** (*sha-räd'* or *sha-räd'*), a kind of riddle, the subject of which is a word that is proposed for discovery from an enigmatical description of its several syllables, taken separately as so many individual and significant words. When dramatic representation is used to indicate the meaning of the syllables and the whole word it is called an acting charade.

**Chara'drius** (*ka-*), the genus to which the plover belongs, forming the type of the family Charadriadæ, which includes also the lapwings, pratincoles, oyster-catchers, turnstones, sanderlings, &c.

**Charas** (*cha'ras*). See *Charras*.

**Char'coal**, a term applied to an impure variety of carbon, especially such as is produced by charring wood. One kind of it is also obtained from bones (see *Bone Black*); lampblack and coke are also varieties. Wood

charcoal is prepared by piling billets of wood in a pyramidal form, with vacuities between them for the admission of air, and causing them to burn slowly under a covering of earth. In consequence of the heat, part of the combustible substance is consumed, part is volatilized, together with a portion of water, and there remains behind the carbon of the wood, retaining the form of the ligneous tissue. Another process consists in heating the wood in close vessels, by which the volatile parts are driven off, and a charcoal remains in the retorts, not so dense as that obtained by the other process. Wood charcoal, well prepared, is of a deep-black colour, brittle and porous, tasteless and inodorous. It is infusible in any heat a furnace can raise; but by the intense heat of a powerful galvanic apparatus it is hardened, and at length is volatilized, presenting a surface with a distinct appearance of having undergone fusion. Charcoal is insoluble in water, and is not affected by it at low temperatures; hence, wooden stakes which are to be immersed in water are often charred to preserve them, and the ends of posts stuck in the ground are also thus treated. Owing to its peculiarly porous texture, charcoal possesses the property of absorbing a large quantity of air or other gases at common temperatures, and of yielding the greater part of them when heated. Charcoal likewise absorbs the odoriferous and colouring principles of most animal and vegetable substances, and hence is a valuable deodorizer and disinfectant. Water which, from having been long kept in wooden vessels, as during long voyages, has acquired an offensive smell, is deprived of it by filtration through charcoal powder. Charcoal can even remove or prevent the putrescence of animal matter. It is used as fuel in various arts, where a strong heat is required, without smoke, and in various metallurgic operations. By cementation with charcoal, iron is converted into steel. It is used in the manufacture of gunpowder. In its finer state of aggregation, under the form of ivoryblack, lampblack, &c, it is the basis of black paint; and mixed with fat oils and resinous matter, to give a due consistence, it forms the composition of printing-ink.

**Chard**, the leaves of artichoke covered with straw in order to blanch them and make them less bitter.—*Beet chards*, the leaf-stalks and midribs of a variety of white beet in which these parts are greatly developed, dressed for the table.

**Chardin** (shâr-dan), JOHN, son of a Protestant jeweller in Paris, and a jeweller himself, was born in 1643. Sent by his father to the East Indies to buy diamonds, Chardin resided a number of years in Persia and India, and latterly published an account of his travels. He settled in London in 1681, was knighted by Charles II., was envoy to Holland for several years, and died in 1713.

**Charente** (shâ-rânt), a river in Western France, rising in the department of Haute-Vienne, and falling into the sea about 8 miles below Rochefort, opposite to the isle of Oleron, after a course of about 200 miles. It gives its name to two departments.—**CHARENTE**, an inland department, formed chiefly out of the ancient province of Angoumois, and traversed by the river Charente; area, 2294 sq. miles; capital Angoulême. Soil generally thin, dry, and arid; one-third devoted to tillage, a third to vineyards, and the remainder meadows, woods, and waste lands. The wines are of inferior quality, but they yield the best brandy in Europe, the celebrated cognac brandy being made in Cognac and other districts. Pop. 360,259.—**CHARENTE-INFÉRIEURE** (an-fâ-ri-eur; 'Lower Charente'), a maritime department, comprises parts of the former provinces of Angoumois and Poitou; area, 2635 sq. miles. Surface in general flat; soil chalky and sandy, fertile, and well cultivated; a considerable portion planted with vines; salt marshes along the coast. The pastures are good, and well stocked with cattle, horses, and sheep. The wine is of common quality, and chiefly used for making brandy. Oysters and sardines abound on the coast. Salt and brandy are the only articles manufactured to any great extent. Capital La Rochelle. Pop. 1891, 456,202.

**Charenton-le-Pont** (shâ-rân-tôn-l-pōn), a town about 5 miles east from Paris, at the confluence of the Marne with the Seine, with numerous mercantile and manufacturing establishments. Pop. 13,535.

**Charge**, in heraldry, signifies the various figures depicted on the escutcheon.—In gunnery *charge* signifies the quantity of powder used at one discharge of a gun.—*Charge*, in military tactics, is the rapid advance of infantry or cavalry against the enemy, with the object of breaking his lines by the momentum of the attack. Infantry generally advance to about 100 yards and fire, then gradually quicken their pace into the charge-step, and dash at the enemy's lines. Cavalry

charge in echelon or column against infantry, which is usually formed in squares to receive them.

**Chargé-d'Affaires** (shâr-zhâ-dâf-âr), the title of an inferior rank of diplomatic agents. See *Minister, Foreign*.

**Charikar**, a town, Afghanistan, in the district of Kohistan, 21 miles north of Cabul. Pop. 5000.

**Cha'ring - Cross**, the titular centre of London, so named from a cross which stood until 1647 at the village of Charing in memory of Eleanor, wife of Edward I. It is now a triangular piece of roadway at Trafalgar Square.

**Chariot**, a term applied to vehicles used both for pleasure and in war. Ancient chariots, such as those used among the Egyptians, Assyrians, Greeks, and Romans, were of various forms. A common form

was open behind and closed in front, and had only two wheels. The chariot was strongly and even elegantly built, but not well adapted for speed. In ancient warfare chariots were of great importance; thus

we read of the 900 iron chariots of Sisera, as giving him a great advantage against the Israelites. The Philistines in their war against Saul had 30,000 chariots. The sculptures of ancient Egypt show that the chariots formed the strength of the Egyptian army, these vehicles being two-horsed and carrying the driver and the warrior, sometimes a

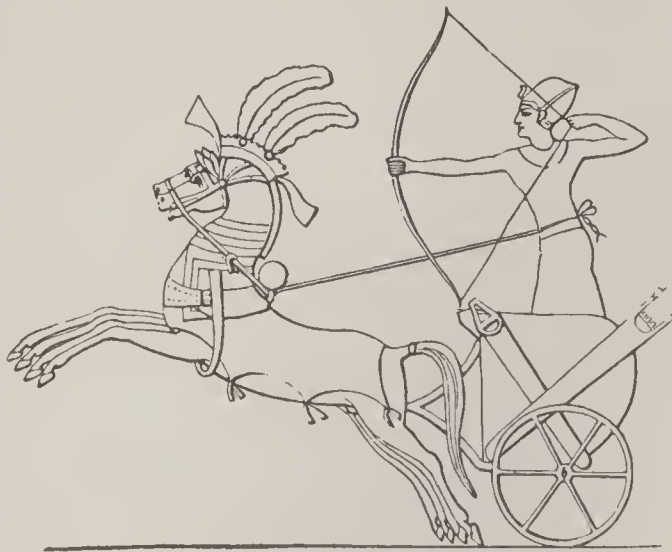

Egyptian War-chariot.—Rosellini.

third man, the shield-bearer. There is no representation of Egyptian soldiers on horseback, and consequently when Moses in his song of triumph over Pharaoh speaks of the 'horse and his rider,' 'rider' must be un-

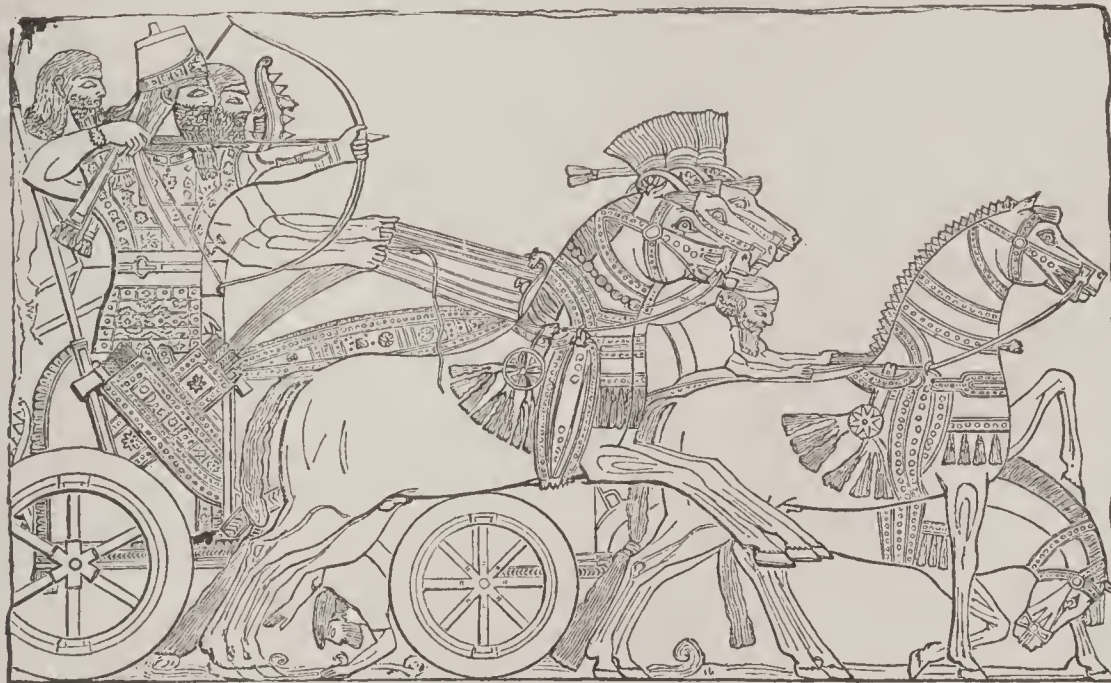

Assyrian War-chariot.—Layard.

derstood to mean chariot-rider. In the Egyptian chariots the framework, wheels, pole, and yoke were of wood, and the fittings of the inside, the bindings of the framework, as well as the harness were chiefly of raw hide or of tanned leather.

We have also numbers of sculptures which give a clear idea of the Assyrian chariots. These resembled the Egyptian in all essential features, containing almost invariably three men—the warrior, the shield-bearer, and the charioteer. A peculiarity of both

is the quiver or quivers full of arrows attached to the side. The Assyrian war-chariot shown in the figure is drawn by three horses abreast, and all the appointments are rich and elaborate. It has, as will be noticed, two quivers crossing each other on the side, filled with arrows, and each also containing a small axe. A socket for holding the spear is also attached. From the front of the chariot a singular ornamental appendage stretches forward. War-chariots had sometimes scythe-like weapons attached to each extremity of the axle, as among the ancient Persians and Britons. Among the Greeks and Romans chariot-races were common. In Britain the name chariot was formerly given to a kind of light travelling carriage.

**Charitable Trusts**, property held in trust for charitable purposes. By English law all bequests for charitable purposes to be valid must be strictly for the public benefit; that is to say, in favour of institutions for the advancement of learning, science, and art, for the support of the poor, or for other objects connected with the welfare of the public. In the U. States the laws of the States permit property, whether it be real or personal, to pass by will or deed for charitable uses. The courts are vested with authority to see such devises properly executed and the intention of the donor carried into effect.

**Charites** (kar'i-tēz), the Greek name of the Graces.

**Charity**, SISTERS OF. See *Sisters of Charity*.

**Charkov** (hār'kof). See *Kharkov*.

**Charlemagne** (shār-lē-mān'; *Carolus Magnus*, Charles the Great), King of the Franks, and subsequently Emperor of the West, was born in 742, probably at Aix-la-Chapelle. His father was Pepin the Short, king of the Franks, son of Charles Martel. On the decease of his father, in 768, he was crowned king, and divided the kingdom of the Franks with his younger brother Carloman, at whose death in 771, Charlemagne made himself master of the whole empire, which embraced, besides France, a large part of Germany. His first great enterprise was the conquest of the Saxons, a heathen nation living between the Weser and the Elbe, which he undertook in 772; but it was not till 803 that they were finally subdued, and brought to embrace Christianity. While he was combating the Saxons, Pope Adrian implored his assistance against Desiderius, king of the Lombards. Charle-

magne immediately marched with his army to Italy, took Pavia, overthrew Desiderius, and was crowned King of Lombardy with the iron crown. In 778 he repaired to Spain to assist a Moorish prince, and while returning his troops were surprised in the valley of Roncesvalles by the Biscayans, and the rear-guard defeated; Roland, one of the most famous warriors of those times, fell in the battle. As his power increased, he meditated more seriously the accomplishment of the plan of his ancestor, Charles Martel, to restore the Western Empire. Having gone to Italy to assist the pope, on Christmas-day 800 he was crowned and proclaimed Caesar and Augustus by Leo III. His son Pepin, who had been made king of Italy, died in 810, and his death was followed the next year by that of Charles, his eldest son. Thus of his legitimate sons one only remained, Louis, king of Aquitania, whom Charlemagne adopted as his colleague in 813. He died Jan. 28, 814, in the forty-seventh year of his reign, and was buried at Aix-la-Chapelle, his favourite and usual place of residence. Charlemagne was a friend of learning, and deserves the name of restorer of the sciences and teacher of his people. He attracted by his liberality the most distinguished scholars to his court (among others, Alcuin, from England), and established an academy in his palace at Aix-la-Chapelle, the sittings of which he attended with all the scientific and literary men of his court. He invited teachers of language and mathematics from Italy to the principal cities of the empire, and founded schools of theology and the liberal sciences in the monasteries. He strove to cultivate his mind by intercourse with scholars; and, to the time of his death, this intercourse remained his favourite recreation. His mother-tongue was a form of German, but he spoke several languages readily, especially the Latin, and was naturally eloquent. He sought to improve the liturgy and church music, and attempted unsuccessfully to introduce uniformity of measures and weights. He built a lighthouse at Boulogne, constructed several ports, encouraged agriculture, and enacted wise laws. He convened councils and parliaments, published capitularies, wrote many letters (some of which are still extant), a grammar, and several Latin poems. His empire comprehended France, most of Catalonia, Navarre, and Aragon; the Netherlands, Germany as far as the Elbe, Saale,



and Eider, Upper and Middle Italy, Istria, and a part of Sclavonia. In private life Charlemagne was exceedingly amiable; a good father and generous friend. In dress and habits he was plain and economical. His only excess was his love of the other sex. In person he was strong and of great stature. He was succeeded by his son Louis (le Débonnaire).

**Charlemont** (shârl-mōn). See *Givet*.

**Charleroi** (shârl-rwä), a town in Belgium, province of Hainaut, on both sides of the river Sambre, 20 miles E.N.E. Mons. It has manufactures of glass, hardware, &c., and woollen stuffs, and in the neighbourhood are extensive pits of iron and coal. Pop. 21,376.

**Charles I.**, surnamed *le Chauve*, or *the Bald*, King of France, was son of Louis le Débonnaire, and was born 823. After his father's death in 840 he fought with his half-brother Lothaire for the empire of the Franks, and finally acquired by the Treaty of Verdun (843) all those territories between the ocean on the one part, and the Meuse, the Scheldt, the Saône, the Rhone, and the Mediterranean, on the other. But he lost Southern Aquitaine to his nephew Pepin, and had to divide Lorraine with his brother Louis the German. In 875 he was crowned emperor by Pope John VIII. He died in 877.

**Charles II.**, surnamed *le Gros*, or *the Fat*, King of France, is also known as Charles III., emperor of Germany, and was born about 832. He was the son of Louis the German, and ascended the French throne in 885 to the prejudice of his cousin, Charles the Simple, but was deposed in 887 and died the following year.

**Charles III.**, King of France, surnamed *the Simple*, was the son of Louis the Stammerer, and born in 879. His reign is noted for his long struggle with the piratical Northmen or Normans, to whose chief, Rollo, he eventually ceded the territory of Normandy. He died in 929.

**Charles IV.**, King of France, surnamed *le Bel*, or *the Handsome*, third son of Philippe le Bel, was borne in 1294, and ascended the throne in 1322. He died in 1328, without male issue, and was the last of the direct line descended from Hugh Capet.

**Charles V.**, surnamed *the Wise*, King of France, was the son of King John, and was born in 1337. His father being taken prisoner by the English at Poitiers, the management of the kingdom devolved on him at an early age. With great skill and

energy, not free, however, from duplicity, he suppressed the revolt of the Parisians and a rising of the peasants, kept the King of Navarre at bay, and deprived the English of a great part of their dominion in France. He died in 1380. He erected the Bastille for the purpose of overawing the Parisians.

**Charles VI.**, surnamed *the Silly*, King of France, and son of the foregoing, was born at Paris in 1368, and in 1388 took the reins of government into his own hands. Four years later he lost his reason, and one of the most disastrous periods of French history began. The kingdom was torn by the rival factions of Burgundians and Armagnacs (Orleanists). In 1415 Henry V. of England crossed over to Normandy, took Harfleur by storm, won the famous victory of Agincourt, and compelled the crazy king to acknowledge him as his successor. Charles died in 1422.

**Charles VII.**, King of France, was born at Paris in 1403. He succeeded only to the southern provinces of the kingdom, Henry VI. of England being proclaimed king of France at Paris. The English dominion in France was under the government of the Duke of Bedford, and so skilfully did the English general conduct his operations that Charles had almost abandoned the struggle as hopeless, when the appearance of Jeanne d'Arc, the *Maid of Orleans*, gave, as if by a miracle, a favourable turn to his affairs, and the struggle ended in the expulsion of the English from all their possessions in France, except Calais. Charles died in 1461.

**Charles VIII.**, King of France, son of Louis XI., was born in 1470, and succeeded his father in 1483. In 1491 he married Anne, the heiress of Brittany, and thereby annexed that important duchy to the French crown. The chief event in the reign of Charles VIII. is his expedition into Italy, and rapid conquest of the kingdom of Naples, a conquest as rapidly lost when a few months later Gonsalvo de Cordova re-annexed it to Spain. Charles was meditating a renewed descent into Italy when he died in 1498.

**Charles IX.**, King of France, son of Henry II. and Catharine de' Medici, born in 1550, ascended the throne at the age of ten years. His haughty and ambitious mother seized the control of the state. Along with the Guises she headed the Catholic League against the Calvinists, and her tortuous and unscrupulous policy helped to embitter the

religious strife of the factions. After a series of Huguenot persecutions and civil wars a peace was made in 1570, which, two years later, on 24th August, 1572, was treacherously broken by the *Massacre of St. Bartholomew's*. The king, who had been little more than the tool of his scheming mother, died two years afterwards, in 1574.

**Charles X.**, King of France, Comte d'Artois, born at Versailles in 1757, grandson of Louis XV., was the youngest son of the dauphin, and brother of Louis XVI. He left France in 1789, after the first popular insurrection and destruction of the Bastille, and afterwards assuming the command of a body of emigrants, acted in concert with the Austrian and Prussian armies on the Rhine. Despairing of success he retired to Great Britain and resided for several years in the palace of Holyrood at Edinburgh. He entered France at the Restoration, and in 1824 succeeded his brother, Louis XVIII. as king. In a short time his reactionary policy brought him into conflict with the popular party, and in 1830 a revolution drove him from the throne. He died in 1836. His grandson, the Comte de Chambord (which see), claimed the French throne as his heir.

**Charles IV.**, Emperor of Germany, of the house of Luxemburg, was born 1316, and was the son of King John of Bohemia. In 1346 he was elected emperor by five of the electoral princes, while the actual emperor Louis the Bavarian was still alive. On the death of the latter a part of the electors elected Count Gunther of Schwarzburg, who soon after died; and Charles at length won over his enemies, and was elected and consecrated emperor at Aix-la-Chapelle. In 1354 he went to Italy and was crowned king of Italy at Milan, and emperor at Rome the year following. On his return to Germany in 1356 Charles issued his Golden Bull (which see) regulating the election of the German emperors. He died at Prague in 1378. Charles was artful, but vacillating, and careless of all interests but those of his own family and his hereditary kingdom of Bohemia. In Germany bands of robbers plundered the country, and the fiefs of the empire were alienated. In Italy Charles sold states and cities to the highest bidder, or if they themselves offered most, made them independent republics. But Bohemia flourished during his reign. He encouraged trade, industry, and agriculture, made Prague a great city, and established there the first German university (1348).

**Charles V.**, Emperor of Germany and King of Spain (in the latter capacity he is called Charles I.), the eldest son of Philip, archduke of Austria, and of Joanna, the daughter of Ferdinand and Isabella of Spain, was born at Ghent, Feb. 24, 1500. Charles was thus the grandson of the Emperor Maximilian and Mary, daughter of Charles the Bold, last duke of Burgundy, and inherited from his grandparents on both sides the fairest countries in Europe, Aragon, Naples, Sicily, Sardinia, Castile, and the colonies in



Charles V. of Germany.

the New World, Austria, Burgundy, and the Netherlands. On the death of Ferdinand, his grandfather, Charles assumed the title of King of Spain. In 1519 he was elected emperor, and was crowned at Aix-la-Chapelle with extraordinary splendour. The progress of the Reformation in Germany demanded the care of the new emperor, who held a diet at Worms. Luther, who appeared at this diet with a safe-conduct from Charles, defended his case with energy and boldness. The emperor kept silent; but after Luther's departure a severe edict appeared against him in the name of Charles, who thought it his interest to declare himself the defender of the Roman Church. A war with France, which the rival claims of Francis I. in Italy, the Netherlands, and Navarre made inevitable, broke out in 1521. Neither side had a decided success till the battle of Pavia in 1525, where Francis was totally defeated and taken prisoner. Charles treated his captive with respect, but with great rigour as regarded the conditions of his release. A league of Italian states,

headed by Pope Clement VII., was now formed against the overgrown power of Charles; but their ill-directed efforts had no success. Rome itself was stormed and pillaged by the troops of the Constable of Bourbon, and the pope made prisoner. Nor was the alliance of Henry VIII. of England with Francis against the emperor any more successful, the war ending in a treaty (Cambray, 1529) of which the conditions were favourable to Charles. A war against the Turks by which Solyman was compelled to retreat, and an expedition against the Dey of Tunis by which 20,000 Christian slaves were released, added to the influence of Charles, and acquired for him the reputation of a chivalrous defender of the faith. In 1537 he made truce with Francis, and soon after, while on his way to the Netherlands, spent six days at the court of the latter in Paris. In 1541 another expedition against the African Moors, by which Charles hoped to crown his reputation, was unsuccessful, and he lost a part of his fleet and army before Algiers without gaining any advantage. A new war with France arose regarding the territory of Milan. The quarrel was patched up by the peace of Crespy in 1545. The religious strife was again disturbing the emperor. Charles, who was no bigot, sought to reconcile the two parties, and with this view alternately courted and threatened the Protestants. At length in 1546 the Protestant princes declared war, but were driven from the field and compelled to submit. But the defection of his ally, Maurice of Saxony, whom Charles had invested with the electoral dignity, again turned the tide in favour of the Protestants. Maurice surprised the imperial camp at Innsbruck in the middle of a stormy night, and Charles with great difficulty escaped alone in a litter. The Treaty of Passau was dictated by the Protestants. It gave them equal rights with the Catholics, and was confirmed three years later by the diet of Augsburg (1555). Foiled in his schemes and dejected with repeated failures, Charles resolved to resign the imperial dignity, and transfer his hereditary estates to his son Philip. In 1555 he conferred on him the sovereignty of the Netherlands, and on January 15, 1556, that of Spain, retiring himself to a residence beside the monastery of Yuste in Estremadura, where he amused himself by mechanical labours and the cultivation of a garden. He still took a strong interest in public affairs, though latterly he

was very much of an invalid, his ill health being partly caused by his high living. He died on Sept. 21, 1558.

**Charles VI.**, German emperor, the second son of the Emperor Leopold I., was born Oct. 1, 1685. He was destined according to the ordinary rules of inheritance to succeed his relative Charles II. on the throne of Spain. But Charles II. by his will made a French prince, Philip, duke of Anjou, grandson of Louis XIV., heir to the Spanish monarchy. This occasioned the war of the Spanish Succession, in which England and Holland took the part of the Austrian claimant. Charles held possession of Madrid for a time, and was supported by the skill of Marlborough and Eugene, but he was eventually obliged to resign Spain to the French claimant, and content himself with the Spanish subject-lands, Milan, Mantua, Sardinia, and the Netherlands (Treaty of Utrecht, 1713, and Treaty of Rastadt, 1714). He became emperor in 1711. In a war against the Turks his armies, led by Eugene of Savoy, gained the decisive victories of Peterwardein and Belgrade. After the death of his only son, Charles directed all his policy and energies to secure the guarantee of the various powers to the Pragmatic Sanction, settling the succession to the Austrian dominions on his daughter Maria Theresa. In 1733 a war with France and Spain regarding the succession in Poland terminated unfavourably for him, he having to surrender Sicily, Naples, and part of Milan to Spain, and Lorraine to France. In 1737 he renewed the war with the Turks, this time unsuccessfully. Charles died Oct. 20, 1740.

**Charles VII.**, Emperor of Germany, born in 1697, was the son of Maximilian Emanuel, elector of Bavaria. In 1726 he succeeded his father as Elector of Bavaria. He was one of the princes who protested against the Pragmatic Sanction, and after the death of Charles VI. (see above), in 1740, he refused to acknowledge Maria Theresa as heiress. In support of his own claims he invaded Austria with an army, took Prague, was crowned king of Bohemia, and in 1742 was elected emperor. But fortune soon deserted him. The armies of Maria Theresa reconquered all Upper Austria, and overwhelmed Bavaria. Charles fled to Frankfort, and returning to Munich in 1744, died there the following year.

**Charles I.**, King of England, Scotland, and Ireland, was born at Dunfermline, Scotland,

## CHARLES I.

in the year 1600, and was the third son of James VI. and Anne of Denmark. He married Henrietta Maria, daughter of Henry IV. of France, and in 1625 succeeded to the throne, receiving the kingdom embroiled in a Spanish war. The first parliament which he summoned, being more disposed to state grievances than grant supplies, was dissolved. Next year (1626) a new parliament was summoned; but the House proved no more tractable than before, and was soon dissolved. In 1628 the king was obliged



Charles I. of England.

to call a new parliament, which showed itself as much opposed to arbitrary measures as its predecessor, and after voting the supplies prepared the Petition of Right, which Charles was constrained to pass into a law. But the determined spirit with which the parliament resisted the king's claim to levy tonnage and poundage on his own authority, led to a rupture, and Charles again dissolved the parliament, resolving to try and reign without one. In this endeavour he was supported by Strafford and Laud as his chief counsellors. With their help Charles continued eleven years without summoning a parliament, using the arbitrary courts of High Commission and Star-chamber as a kind of cover for pure absolutism, and raising money by unconstitutional or doubtful means. In 1637 John Hampden began the career of resistance to the king's arbitrary measures by refusing to pay ship-money, the right to levy which, without authority of parliament, he was determined to bring before a court of law. His cause was argued for

twelve days in the Court of Exchequer; and although he lost it by the decision of eight of the judges out of twelve, the discussion of the question produced a very powerful impression on the public mind. It was in Scotland, however, that formal warlike opposition was destined to commence. The attempts of Charles to introduce an Anglican liturgy into that country produced violent tumults, and gave origin to the famous *Covenant* in 1638, to oppose the king's design. An English army was sent north, but was defeated by the army of the Covenanters, and in 1640 a parliament was again summoned, which proved to be the famous Long Parliament. An account of the struggle between king and parliament, the trial and execution of Strafford and Laud, &c., cannot here be given, but the result latterly was that both king and parliament made preparations for war. The king had on his side the great bulk of the gentry, while nearly all the Puritans and the inhabitants of the great trading towns sided with the parliament. The first action, the battle of Edgehill (23d Oct. 1642), gave the king a slight advantage; but nothing very decisive happened till the battle of Marston Moor, in 1644, where Cromwell routed the royalists. The loss of the battle of Naseby, the year following, completed the ruin of the king's cause. Charles at length gave himself up to the Scottish army at Newark (5th May, 1646). After some negotiations he was surrendered to the commissioners of the parliament. The extreme sect of the Independents, largely represented in the army and headed by Cromwell, now got the upper hand, and, coercing the parliament and the more hesitating of the Presbyterians, brought Charles to trial for high treason against the people, and had sentence of death pronounced against him. All interposition being vain, he was beheaded before the Banqueting House, Whitehall, on 30th Jan. 1649, meeting his fate with great dignity and composure. Charles had many good qualities. Possessed of a highly-cultivated mind, with a fine judgment in arts and letters, he was also temperate, chaste, and religious, and, although somewhat cold in his demeanour, kind and affectionate. Nor was talent wanting to him. But these merits were counterbalanced and all but neutralized by a want of self-reliance and a habit of vacillation, which in his position came near being, if it was not altogether, a kind of insincerity.

Charles II., King of England, Ireland, and Scotland, son of Charles I. and Henrietta Maria of France, was born in 1630. He was a refugee at the Hague on the death of his father, on which he immediately assumed the royal title. Cromwell was then all-powerful in England; but Charles accepted an invitation from the Scots, who had proclaimed him their king July, 1650, and, passing over to Scotland, was crowned at Scone (1651). Cromwell's approach made him take refuge amongst the English royalists, who, having gathered an army, encountered Cromwell at Worcester, and were totally defeated. With great difficulty Charles escaped to France. On the death of Cromwell the Restoration effected without a struggle by General Monk set Charles on the throne after the declaration of Breda, his entry into the capital (29th May, 1660) being made amidst universal acclamations. In 1662 he married the Infanta of Portugal, Catharine of Braganza, a prudent and virtuous princess, but in no way calculated to acquire the affection of a man like Charles. For a time his measures, mainly counselled by the chancellor Lord Clarendon, were prudent and conciliatory. But the indolence, extravagance, and licentious habits of the king soon involved the nation as well as himself in difficulties. Dunkirk was sold to the French to relieve his pecuniary embarrassment, and war broke out with Holland. A Dutch fleet entered the Thames, and burned and destroyed ships as far up as Chatham. The great plague in 1665, and the great fire of London the year following, added to the disasters of the period. In 1667 Clarendon was dismissed, and a triple alliance between England, Holland, and Sweden, for the purpose of checking the ambition of Louis XIV., followed; but the extravagance of the king made him willing to become a mere pensioner of Louis XIV., with whom he arranged a private treaty against Holland in 1670. The *Cabal* ministry was by this time in power, and they were quite ready to break the triple alliance and bring about a rupture with the Dutch. As the king did not choose to apply to parliament for money to carry on the projected war he caused the exchequer to be shut up in January, 1672, and by several other disgraceful and arbitrary proceedings gave great disgust and alarm to the nation. The war ended in failure, and the *Cabal* ministry was dissolved in 1673. The year 1678 was distinguished by the pretended

Popish plot of Titus Oates, which led to the exclusion of R. Catholics from parliament. In 1679 the Habeas Corpus Act was passed, and the temper of the parliament was so much excited that the king dissolved it. A new parliament which assembled in 1680 had to be dissolved for a like reason, and yet another which met the year following at Oxford. Finally Charles, like his father, determined to govern without a parliament, and after the suppression of the Rye House plot and the execution of Russell and Sidney Charles became as absolute as any sovereign in Europe. He died from the consequences of an apoplectic fit in February, 1685, after having received the sacrament according to the rites of the Roman Church. Charles was a man of wit, and possessed an easy good-nature, but was entirely selfish, and indifferent to anything but his own pleasure. He had no patriotism, honour, or generosity, but was not destitute of the ability to rule. He had no legitimate children. His mistresses were numerous, and several of them were raised to the highest ranks of nobility. Six of the sons he had by them were made dukes, viz. Monmouth (by Lucy Walters), St. Albans (by Nell Gwynn), Richmond (by Louise de Querouaille), and Cleveland, Grafton, and Northumberland (by Barbara Villiers).

Charles XII., King of Sweden, was born at Stockholm, June 27, 1682. On the death of his father, in 1697, when he was but fifteen years old, he was declared of age by the estates. To his jealous neighbours this seemed a favourable time to humble the pride of Sweden. Frederick IV. of Denmark, Augustus II. of Poland, and the Czar Peter I. of Russia concluded an alliance which resulted in war against Sweden. With the aid of an English and Dutch squadron the Danes were soon made to sign peace, but Augustus of Saxony and Poland, and the czar were still in the field. Rapidly transporting 20,000 men to Livonia, Charles stormed the czar's camp at Nerva, slaying 30,000 Russians and dispersing the rest (30th Nov. 1700). Crossing the Dwina he then attacked the Saxons and gained a decisive victory. Following up this advantage he won the battle of Clissau, drove Augustus from Poland, had the crown of that country conferred on Stanislaus Leczinsky, and dictated the conditions of peace at Altranstadt in Saxony in 1706. In September, 1707, the Swedes left Saxony, Charles taking the shortest route to Moscow.

At Smolensk he altered his plan, deviated to the Ukraine to gain the help of the Cossacks, and weakened his army very seriously by difficult marches through a district extremely cold and ill supplied with provisions. In this condition Peter marched upon him with 70,000 men, and defeated him completely at Pultawa. Charles fled with a small guard and found refuge and an honourable reception at Bender, in the Turkish territory. Here he managed to persuade the Porte to declare war against Russia. The armies met on the banks of the Pruth (July 1, 1711) and Peter seemed nearly ruined, when his wife, Catharine, succeeded in bribing the grand vizier, and procured a peace in which the interests of Charles were neglected. The attempts of Charles to rekindle a war were vain, and after having spent some years at Bender he was forced by the Turkish government to leave. Arrived in his own country in 1714, he set about the measures necessary to defend the kingdom, and the fortunes of Sweden were beginning to assume a favourable aspect when he was slain by a cannonball as he was besieging Frederikshall, Nov. 30, 1718. Firmness, valour, and love of justice were the great features in the character of Charles, but were disfigured by an obstinate rashness. After his death Sweden sank from the rank of a leading power.

**Charles XIII.**, King of Sweden, was born in 1748, being the second son of King Adolphus Frederick. In the war with Russia, in 1788, he received the command of the fleet, and defeated the Russians in the Gulf of Finland. After the murder of his brother, Gustavus III., in 1792, he was placed at the head of the regency, and gained universal esteem in that position. The revolution of 1809 placed him on the throne at a very critical period, but his prudent conduct procured the union of Sweden with Norway, Nov. 4, 1814. He adopted as his successor Marshal Bernadotte, who became king on the death of Charles, Feb. 5, 1818.

**Charles XIV.** See *Bernadotte*.

**Charles I.**, King of Spain. See *Charles V.*, *Emperor of Germany*.

**Charles IV.**, King of Spain, born at Naples 12th Nov. 1784, succeeded his brother Ferdinand VI. in 1788, was all his life completely under the influence of his wife and her paramour Godoy. In 1808 Charles abdicated in favour of Napoleon. He died in 1819.

**Charles**, ARCHDUKE OF AUSTRIA, third son of the Emperor Leopold II., was born in Florence 5th Sept. 1771. After distinguishing himself in various campaigns, in 1796 he was appointed commander-in-chief of the Austrian army on the Rhine, and won several victories against the French. In 1805 he commanded in Italy against Masséna, and won Caldiero (31st Oct.); but in the campaign of 1809 in Germany against Napoleon he was unsuccessful, the battle of Wagram (5th and 6th July) laying Austria at the feet of the French emperor. With that event the military career of Charles closed. He died in 1847. He published several military works of value.

**Charles Albert**, King of Sardinia, born 1798, was the son of Charles Emmanuel, prince of Savoy-Carignan. In 1831 he succeeded to the throne on the death of Charles Felix, but his government at first greatly disappointed the liberal party by its despotic tendencies. It was not till near 1848 that, seeing the growing strength of the progressive and national movement in Italy, he took up the position of its champion. As such he took the field against Austria on behalf of the Lombardo-Venetian provinces, but was crushingly defeated at Novara 23d March, 1849. He abdicated in favour of his son, Victor Emmanuel, and, retiring to Portugal, died 28th July, 1849.

**Charles Edward Stuart**, called the *Pretender*, grandson of James II. king of England, son of James Edward and Clementina, daughter of Prince Sobieski, was born in 1720 at Rome. In 1742 he went to Paris and persuaded Louis XV. to assist him in an attempt to recover the throne of his ancestors. Fifteen thousand men were on the point of sailing from Dunkirk, when the English admiral Norris dispersed the whole fleet. Charles now determined to trust to his own exertions. Accompanied by seven officers he landed on the west coast of Scotland, from a small ship called the *Doutelle*. Many Lowland nobles and Highland chiefs went over to his party. With a small army thus formed he marched forward, captured Perth, then Edinburgh (Sept. 17, 1745), defeated an army of 4000 British under Sir John Cope at Prestonpans (Sept. 22), and advancing obtained possession of Carlisle. He now caused his father to be proclaimed King, and himself Regent of England; removed his head-quarters to Manchester, and soon found himself within 100 miles of London, where many of his friends awaited

his arrival. The rapid successes of the adventurer now caused a part of the British forces in Germany to be recalled. Want of support, disunion, and jealousy among the adherents of the house of Stuart, some errors, and the superior force opposed to him, compelled Prince Charles to retire in the beginning of 1746. The victory at Falkirk (Jan. 28, 1746) was his last. As a final attempt he risked the battle of Culloden against the Duke of Cumberland, April 16, 1746, in which his army was defeated and entirely



Prince Charles Edward Stuart.

dispersed. The prince now wandered about for a long time through the wilds of Scotland, often without food, and the price of £30,000 sterling was set upon his head. At length, on Sept. 20, 1746, five months after the defeat of Culloden, he escaped in a French frigate. He received a pension of 200,000 livres yearly from France, and of 12,000 doubloons from Spain. Forced to leave France by the terms of the Peace of Aix-la-Chapelle (1748) he went to Italy, and in 1772 married a princess of Stolberg-Gedern, from whom eight years later he was separated. (See *Albany*.) He latterly fell into habits of intoxication, and he died Jan. 31, 1788, and was buried at Frascati. The funeral service was performed by his only surviving brother, the Cardinal of York, with whose death in 1807 the Stuart line ended. The cardinal received a pension from Britain of £4000 a year till his death.

**Charles Martel'**, ruler of the Franks, was a son of Pepin Héristal. His father had governed as mayor of the palace under the weak Frankish kings with so much

justice that he was enabled to make his office hereditary in his family. Chilperic II., king of the Franks, refusing to acknowledge Charles Martel as mayor of the palace, the latter deposed him, and set Clothaire IV. in his place. After the death of Clothaire he restored Chilperic, and subsequently placed Thierrri on the throne. Charles Martel rendered his rule famous by the great victory which he gained in October, 732, over the Saracens, near Tours, from which he acquired the name of *Martel*, signifying *hammer*. He died 741. Charlemagne was his grandson. See *Charlemagne*.

**Charles the Bold**, Duke of Burgundy, son of Philip the Good and Isabella of Portugal, born at Dijon Nov. 10, 1433. While his father yet lived Charles left Burgundy, and forming an alliance with some of the great French nobles for the purpose of preserving the power of the feudal nobility, he marched on Paris with 20,000 men, defeated Louis XI. at Montlhéri, and won the counties of Boulogne, Guines, and Ponthieu. Succeeding his father in 1467 he commenced his reign by severe repression of the citizens of Liége and Ghent. In 1468 he married Margaret of York, sister of Edward IV. of England. Liége having rebelled, the duke stormed and sacked the town. In 1470 the war with France was renewed, and although the duke was forced to sue for a truce he soon took up arms anew, and, crossing the Somme, stormed and fired the city of Nesle. Louis meanwhile involved him in greater embarrassments by exciting against him Austria and the Swiss. Charles, ever ready to take up a quarrel, threw himself on Germany with characteristic fury, and lost ten months in a futile siege of Neuss. He was successful, however, in conquering Lorraine from Duke René. Charles now turned his arms against the Swiss, took the city of Granson, putting 800 men to the sword. But this cruelty was speedily avenged by the descent of a Swiss army, which at the first shock routed the duke's forces at Granson, March 3, 1476. Mad with rage and shame Charles gathered another army, invaded Switzerland, and was again defeated with great loss at Morat. The Swiss, led by the Duke of Lorraine, now undertook the reconquest of Lorraine, and obtained possession of Nancy. Charles marched to recover it, but was utterly routed and himself slain. The house of Burgundy ended in him, and his death

CHARLES THE GREAT—CHARLOTTE AUGUSTA.

without male heirs removed the greatest of those independent feudal lords whose power stood in the way of the growth of the French monarchy. His daughter Mary married Maximilian of Germany, but most of his French territory passed into the hands of the French king.

**Charles the Great.** See *Charlemagne*.

**Charles River,** a river in Massachusetts, which flows into Boston harbour, dividing Boston from Charleston.

**Charles's Wain.** See *Bear, Great and Little*.

**Charleston,** a city and seaport of South Carolina, on a tongue of land formed by the confluence of the rivers Cooper and Ashley, which unite just below the city, and form a spacious and convenient harbour

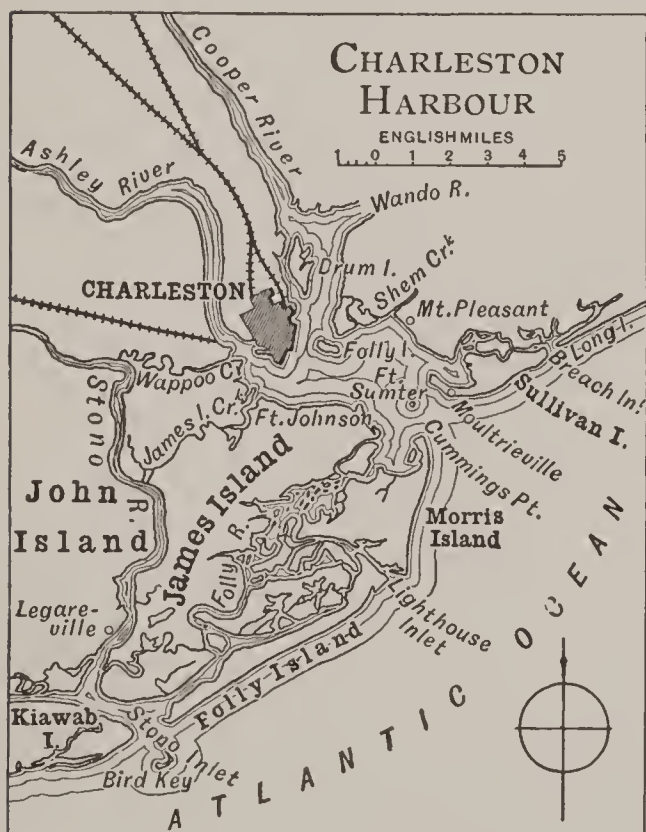

extending about 7 miles to the Atlantic, and defended by several forts. The city is regularly laid out, most of the principal thoroughfares being 60 to 70 feet wide and bordered with fine shade-trees. It is much the largest town in the state, and is one of the leading commercial cities in the south. The staple exports are cotton (to the value of, say, \$20,000,000 annually), cotton-seed, rice, rosin and turpentine, lumber, and phosphate (see that art). The civil war greatly damaged the trade, but there has since been marked commercial and industrial progress. Yellow fever has made frequent ravages in

Charleston, but on the whole it is considered more healthy than most other Atlantic towns in the southern states. It was the scene of the outbreak of the civil war on April 12, 1861, and was evacuated by the Confederates on February 17, 1865. On 31st August, 1886, the coast region of the U. States from Alabama to New York experienced a series of earthquake shocks, from which Charleston in particular suffered severely, many lives and about five million dollars worth of property being destroyed. Pop. 1890, 54,955.

**Charleston, W. Va.,** capital of the State, 65 miles S. of Parkersburg; State House is a fine building erected 1870; it has several factories and 2 banks. Pop. 1890, 6742.

**Charlestown,** a former city and seaport of the United States, since 1874 part of the municipality of Boston, with which it is connected by bridges across Charles River. In the south-east part there is one of the chief navy-yards in the United States, occupying an area of from 70 to 80 acres. Bunker Hill, on which was fought one of the most celebrated battles of the American revolution, is in this town, and there is, on the site, a commemorative monument 220 feet high.

**Charleville** (shârl-vêl), a town, France, department Ardennes, 1 mile N. of Mézières, with which it communicates by a bridge across the Meuse. It has wide and regular-built streets, considerable manufactures, and a large trade in coal, iron, wine, &c. Pop. 16,185.

**Char'lock,** the vulgar name of *Sināpis arvensis*, a common yellow weed in corn-fields, also called wild mustard. Jointed or white charlock is *Raphānus Raphanistrum*. It also is a common cornfield weed, but having white or straw-coloured flowers and jointed pods.

**Charlotte,** a town of the U. States, in North Carolina, with a university and several manufactories. Pop. 1890, 11,555.

**Charlotte-Amalia,** a town, West Indies, capital of the Island of St. Thomas, one of the Virgin Islands, belonging to the Danes, on the s. side of the island. It has an excellent harbour, and is a considerable entrepôt for goods for the neighbouring islands. Pop. about 12,000.

**Charlotte Augusta,** PRINCESS, daughter of Queen Caroline and George IV., was born at Carlton House, Jan. 7, 1796. She was carefully educated and highly accomplished. In 1816 she married Prince Leo-



pold of Coburg, afterwards king of the Belgians, and died Nov. 5, 1817, after being prematurely delivered of a dead child.

**Charlottenburg** (shâr-lot'en-burh), a town of Prussia, on the Spree, about 3 miles from Berlin, with a royal palace and park, and many places of amusement, as also a number of industrial and manufacturing establishments. Pop. 1890, 76,859.

**Charlottesville**, Albemarle Co., Va., site of the Univ. of Virginia, much enlarged 1898; has 2 banks and factories. Pop. 5591.

**Charlottetown**, a town of British North America, capital of Prince Edward Island, on Hillsborough Bay, 110 miles N. of Halifax. It contains handsome public buildings and churches, is advantageously situated for commerce, and its harbour is one of the best in North America. Pop. 1891, 11,374.

**Charm**, anything believed to possess some occult or supernatural power, such as an amulet, spell, &c., but properly applied (as the name, derived from Lat. *carmen* a song, indicates) to spells couched in formulas of words or verses.

**Charnel-house**, a chamber or building under or near churches where the bones of the dead are deposited.

**Charon** (kâ'ron), in Greek mythology, the son of Erebus and Night. It was his office to ferry the dead in his crazy boat over the rivers of the infernal regions, for which office he received an obolus, or farthing, which accordingly was usually put into the mouth of the deceased. He was represented as an old man, with a gloomy aspect, matted beard, and tattered garments.

**Charpie** (shâr'pē), lint for dressing wounds.

**Char'poy**, in the East Indies, a small portable bed, consisting of a wooden frame resting on four legs, with bands across to support the bedding.

**Charqui** (châr'kē), jerked beef, the Chilian name of which the English term is a corruption.

**Charr.** See *Char*.

**Charras** (char'ras), a resinous substance which exudes from the Indian hemp and is collected for use as a narcotic or intoxicant, forming a considerable article of trade in Asia.

**Chart**, a hydrographical or marine map, that is a draught or projection of some part of the earth's surface, with the coasts, islands, rocks, banks, channels, or entrances into harbours, rivers, and bays, the points of compass, soundings, or depth of water,

&c., to regulate the courses of ships in their voyages. The term *chart* is applied to a marine map; *map* is applied to a draught of some portion of land (often including sea also). A *plane chart* is one in which the meridians are supposed parallel to each other, the parallels of latitude at equal distances, and of course the degrees of latitude and longitude everywhere equal to each other. A great number of excellent charts are produced by the hydrographic department of the British admiralty and are sold at a low rate. The U. States Coast Survey Department produces similar charts. See *Map*.

**Charter**, a written instrument, executed with usual forms, given as evidence of a grant, contract, or other important transaction between man and man. *Royal charters* are such as are granted by sovereigns to convey certain rights and privileges to their subjects, such as the Great Charter, granted by King John (see *Magna Charta*), and charters granted by various sovereigns to boroughs and municipal bodies, to universities and colleges, or to colonies and foreign possessions; somewhat similar to which are charters granted by the state or legislature to banks and other companies or associations, &c.

**Charter-house**, a celebrated school and charitable foundation in the city of London. In 1370 Sir Walter Manny and Northburgh, bishop of London, built and endowed it as a priory for Carthusian monks (hence the name, a corruption of *Chartreuse*, the celebrated Carthusian convent). After the dissolution of the monasteries it passed through several hands till it came into the possession of Thomas Sutton, who converted it into an hospital, richly endowed, consisting of a master, preacher, head schoolmaster, with forty-four boys and eighty decayed gentlemen, together with a physician and other officers and servants of the house. Each boy is educated at a certain expense, and each pensioner receives food, clothing, lodging, and an allowance of about £26 a year. The poor brethren must be over fifty years of age, and members of the Church of England. The Charter-house School has been removed to new buildings near Godalming in Surrey, while the non-academic department of the Charter-house still remains in the old buildings. The school has a high reputation, and many lads are educated there other than the scholars properly so called. Several of the famous men who

have received their education at the Charter-house are Isaac Barrow, Addison, Steele, John Wesley, Blackstone, Grote, Thirlwall, Havelock, John Leech, and Thackeray.

**Charter-party** is a contract executed by the freighter and the master or owner of a ship, containing the terms upon which the ship is hired to freight. The masters and owners usually bind themselves that the goods shall be delivered (dangers of the sea excepted) in good condition. The charterer is bound to furnish the cargo at the place of lading and to take delivery at the port of discharge within specified periods called *lay days*.

**Chartier** (shär-tyā), ALAIN, a French poet and moralist, born, it is supposed, at Bayeux about 1386, died in 1449. His contemporaries considered him the father of French eloquence. His poems are often graceful and nervous, and his vigorous prose contains many fine thoughts and prudent maxims.

**Chartism**, CHARTISTS, names for a political movement and its supporters that formerly caused great excitement in Britain. The reform bill passed in 1832 gave political enfranchisement to the middle-classes, but to the large body of the working-classes it brought, primarily at least, no additional advantages, and this circumstance was turned to account by many demagogues, who urged on the people the idea that they had been betrayed by the middle-classes and their interests sacrificed. A period of commercial depression and a succession of bad harvests brought discontent to a head in the Chartist movement. It was founded on the general idea that the evils under which the people were labouring were due to the misconduct of government and a defective political representation. In 1838 the famous 'Charter,' or 'People's Charter,' was prepared by a committee of six members of parliament and six working-men. It comprised six heads, namely:—1. Universal suffrage, or the right of voting for every male of twenty-one years of age. 2. Equal electoral districts. 3. Vote by ballot. 4. Annual parliaments. 5. No other qualification to be necessary for members of parliament than the choice of the electors. 6. Members of parliament to be paid for their services. Immense meetings were now held throughout the country, and popular excitement mounted to the highest pitch. Physical force was advocated as the only means for obtaining satisfaction. In June, 1839, after the refusal of the House

of Commons to consider a monster petition in favour of the Charter, serious riots took place. In 1848 the French revolution of February stirred all the revolutionary elements in Europe, and a great demonstration on the part of the Chartists was organized. But the preparations taken by the government for defence prevented outbreaks of any consequence, and Chartism then gradually declined. Some of the demands of the Charter have been adopted by the Liberal party and made into law; while the more advanced section of Chartism has been absorbed by Socialistic and Republican movements.

**Chartres** (shärtr), a city, France, capital of the department Eure-et-Loire, 49 miles s.w. Paris. It is a very ancient city; a large number of the houses are built of wood and plaster, and have their gables toward the street. The cathedral, one of the most magnificent in Europe, is rendered conspicuous by its two spires surmounting the height on which the city stands. Manufactures: woollen, hosiery, hats, earthenware, and leather; there is a considerable trade. Pop. 21,080.

**Chartreuse** (shär-treuz), or GREAT CHARTREUSE, a famous Carthusian monastery in South-eastern France, a little north-east of Grenoble, situated at the foot of high mountains, 3280 feet above sea-level, the headquarters of the order of the Carthusians. It was founded in 1084, but the present building, a huge, plain-looking pile, dates from 1676. The monks of this monastery manufacture the well-known liquor called *Chartreuse*, which owes its special properties to the aromatic plants growing on the Alps.

**Char'tulary**, a record or register in which the charters, title-deeds, &c., of any corporation were copied for safety and convenience of reference. They were often kept by private families.

**Charybdis** (ka-rib'dis), an eddy or whirlpool in the Straits of Messina, celebrated in ancient times, and regarded as the more dangerous to navigators because in endeavouring to escape it they ran the risk of being wrecked upon Scylla, a rock opposite to it. There are several whirlpools in this region which may have been dangerous enough to the undecked boats of the Greeks, but none, according to Admiral Smyth, which the modern navigator with due caution may not easily pass.

**Chase**: (1) in printing, an iron frame used to confine types when set in columns or

pages. (2) The part of a gun between the trunnions and the swell of the muzzle, or in modern guns, in which the muzzle has no swell, the whole of that part of a gun which is in front of the trunnions.

**Chase**, or **CHACE**, an open piece of ground stored with wild beasts or game, and belonging to a private proprietor. It differs from a forest, which is not private property and is invested with privileges, and from a park, which is inclosed.

**Chase**, **SALMON PORTLAND**, American statesman and jurist, born in N. Hampshire, 1808. Having adopted the law as his profession he settled at Cincinnati and acquired a practice there. He early showed himself an opponent of slavery, and was the means of founding the Free-soil party, which in time gave rise to the great Republican party—the power that brought the downfall of slavery. In 1849–55 he was a member of the U.S. Senate, in which he vigorously opposed the extension of slavery into the new territories. In 1855 he was elected governor of Ohio, being re-elected in 1857. In 1860 he was an unsuccessful candidate for the presidency. In 1861 he was nominated secretary of the treasury, and in this post was signally successful in providing funds for carrying on the civil war. In 1864 he resigned office, and was appointed chief-justice of the supreme court. He died in 1873.

**Chasidim** (*has'i-dēm*), or **PIETISTS**, the name of a Jewish sect which appeared in the middle of the last century. Its adherents are strongly inclined to mysticism, depreciate the Old Testament and its ordinances, believe in extraordinary cures, &c. They are most numerous in Russian Poland, Roumania, and some parts of Galicia and Hungary, and are regarded with great antipathy by the orthodox Jews. Chasidim is also the name given to a sect which sprang up about the 2d century B.C. This party is credited with the origin of the revolt of the Maccabees, with combating the erroneous notions bred among the Jews by the study of Grecian philosophy, and with being the parent stock of the Pharisees.

**Chasing** is the art of working decorative forms in low-relief in gold, silver, or other metals. It is generally practised in connection with *repoussé* work, in which the figures are punched out from behind and are then sculptured on the front or *chased* with the graver

**Chassepot Rifle** (*shàs-pō*), a breech-

loading rifle, named after its inventor, and adopted as the firearm of the French infantry in 1866, but since given up. It was about 4 lbs. lighter than the needle-gun and about 1 lb. lighter than the Martini-Henry rifle.

**Chasseurs** (*shàs-œur*; a French word signifying 'hunters'), a name given to various sections of light infantry and cavalry in the French service.

**Chastelard**, or **CHÂTELARD**, **PIERRE DE BOSCOBEL DE**, a young Frenchman, celebrated for his infatuated passion for Mary Queen of Scots, was born 1540 in Dauphiné. He was of good family, handsome, with a turn for verse-making, and possessed of all the accomplishments of a gallant of the age. He fell madly in love with Mary Stuart at the court of Francis II., followed her to Scotland, and, being graciously received, had the infatuation to invade twice the royal bed-chamber while Mary was being undressed by her maids. He was tried publicly at St. Andrews and hanged (1563), the queen resisting all appeals for pardon. She is said to have encouraged his passion more than was consistent with prudence.

**Chas'uble**, the upper garment worn by a priest during the celebration of mass. It



A, Ancient form of Chasuble: 1, Apparel of the neck, 2 2 2, Chasuble. 3, Orphreys of the chasuble. 4, The stole. 5 5, The alb. 6, Apparel of the alb. 7, The maniple.  
B, Modern form of Chasuble.

was originally circular, had a hole in the middle for the head, but no holes for the arms. In later times the sides were cut

away to give a freer motion to the arms, and it has now become an oblong garment hanging down before and behind, made of rich materials, as silk, velvet, cloth of gold, and has a cross embroidered on the back.

**Chat**, the popular name of birds of the genus *Saxicola*, family Sylviadæ or warblers. They are small, lively birds, moving incessantly and rapidly about in pursuit of the insects on which they chiefly live. There are three species found in Britain, the stone-chat, whin-chat, and wheatear. The yellow-breasted chat of the United States is a larger bird, belonging to the genus *Icteria* (*I. polyglotta*), family Turdidæ or thrushes.

**Château** (shä-tō), the French term for a castle or mansion in the country; a country-seat.—*Château en Espagne*, literally, a castle in Spain; a castle in the air: a phrase of doubtful origin.

**Châteaubriand** (shä-tō-bri-än), FRANÇOIS AUGUSTE VICOMTE DE, a celebrated French author and politician, was born at St. Malo, in Brittany, of a noble family, September 14, 1768. After serving in the navy and the army he travelled in North America; but the news of the flight of Louis XVI. and his arrest at Varennes brought him back to France. Shortly after he quitted France and joined with other emigrants the Prussian army on the Rhine. After being wounded at the siege of Thionville and suffering many miseries, he made his way to London, where, friendless and penniless, he was just able to earn a subsistence by giving lessons in French and doing translations. Here he published in 1797 his *Essai Historique*, which met with but small success. At this time the death of his mother and the accounts of her last moments transmitted to him by his sister helped to effect a certain change in the religious opinions of Châteaubriand, and from a not very profound sceptic he became a not very profound believer. In 1800 he returned to France, and in the following year published his romance of *Atala*, the scene of which is laid in America, and the year after his celebrated work, *Le Génie du Christianisme*, which is a kind of brilliant picture of Christianity in an æsthetic and romantic aspect. Style, power of description, and eloquence are the merits of the book rather than any depth of thought; but it carried the author's reputation far and wide, and contributed much to the religious reaction of the time. After a short career as diplomatist under Napoleon, Châteaubriand

made a tour in the East (1806-7), visiting Greece, Asia Minor, and the Holy Land. As the fruit of his travels he published *Les Martyrs* (1809) and *Itinéraire de Paris à Jérusalem* (1811). He hailed the restoration of Louis XVIII. with enthusiasm, was appointed ambassador to Berlin, and then to London, but in 1824 quarrelled with the premier, M. de Villèle, and was summarily dismissed. On the revolution of 1830 he refused to take the oath of allegiance to Louis Philippe, forfeiting thus a pension of 12,000 francs. At this time his writings were chiefly political, and mostly appeared as newspaper articles, pamphlets, &c. In his later years he wrote several works, but none of the value of his earlier productions. He died 4th July, 1848, leaving memoirs (*Mémoires d'outre Tombe*) which contain severe judgments on contemporary men and things.

**Châteaudun** (shä-tō-dün), a town, France, dep. Eure-et-Loire, 26 miles s.s.w. of Chartres, near the Loire. The old castle of the counts of Dunois overlooks the town. Pop. 5859.

**Château-Gaillard** (shä-tō-gā-yär), a celebrated feudal fortress in France, near Andelys (dep. Eure), built by Richard Cœur de Lion. As late as the 15th century it was considered one of the strongest fortresses in Normandy. Its picturesque situation on a high rock overlooking the river has made it a favourite subject for artists. Turner has twice represented it.

**Château-Gontier** (gon-tyā), a town, France, department of Mayenne, on the Mayenne, with linen and serge manufactories, bleachfields, tanneries. Pop. 7334.

**Château-Lafitte**, CHÂTEAU-LATOIR, CHATEAU-MARGAUX (mär-gō), famous vineyards, all in the department of the Gironde, France, furnishing the best of the red wines of Bordeaux. See *Bordelais Wines*.

**Châteauroux** (shä-tō-rö), a town, France, capital of the department of Indre, 144 miles s.s.w. of Paris, on the Indre. It has straight, broad streets, and spacious squares. Cloth, cotton hosiery, woollen yarn, paper, &c., are made; and there are tanneries and dyeworks. Pop. 19,469.

**Château-Thierry** (ti-ā-ri), a town, France, dep. Aisne, on the Marne, 38 miles s.s.w. of Laon, with manufactures of linen and cotton twist, pottery, leather, &c. It is the birthplace of La Fontaine. Pop. 6244.

**Châtelet** (shät-lā; diminutive of *château*) was anciently a small castle or fortress. Two such buildings at Paris gained some

historical importance—the Grand and Petit Châtelet. The Grand Châtelet was the castle of the counts of Paris, and was long the seat of certain courts of justice; but latterly, like the Petit Châtelet, was converted into a prison.

**Châtelet** (shät-lā), a manufacturing town of Belgium, prov. of Hainaut, in the Sambre. Pop. 10,955.—**CHÂTELINEAU**, opposite to it, has a pop. of 9026.

**Châtelleraut** (shä-tel-rō), a town, France, department Vienne, 20 miles N.N.E. of Poitiers, on the Vienne. It is a place of some antiquity, having once been the capital of a duchy which, in 1548, was bestowed by Henry II. on the Earl of Arran, regent of Scotland, and still gives a title to his descendant, the Duke of Hamilton. It manufactures firearms on an extensive scale, also cutlery, hardware, jewelry, &c. Pop. 13,848.

**Chatham** (chat'am), a town, naval arsenal, and seaport, England, county Kent, on the Medway, about  $34\frac{1}{2}$  miles by rail from London, adjoining Rochester so closely as to form one town with it. It is a parliamentary borough returning one member to the House of Commons. The importance of Chatham is due to the naval and military establishments at Brompton in its immediate vicinity. The royal dockyard was founded by Queen Elizabeth previous to the sailing of the Armada. It has been greatly enlarged in recent years, and is now about two miles in length, with most capacious docks, in which the heaviest warships can be equipped and sent directly to sea. Building-slips, saw-mills, metal mills, &c., and all the requisites of a great naval station are here on the largest scale and in the finest order. The military establishments include extensive barracks, arsenal, and park of artillery, hospital, store-houses and magazines, &c. The town is poorly built, but is defended by a strong line of fortifications which also serve as a flank defence for the metropolis. Pop. 1891, 59,389.

**Chatham**, a town of Canada, prov. Ontario, on the river Thames, 11 miles north of Lake Erie, with manufactures of machinery, iron castings, and woollens, and a trade in lumber, &c. Pop. 1891, 9052.

**Chatham**, a town in New Brunswick, on the Miramichi, the seat of a Roman Catholic bishop, with a large trade in lumber. Pop. 5672.

**Chatham**, **WILLIAM PITT, EARL OF**, one of the most illustrious statesmen of Britain, the son of Robert Pitt of Boconnoc, in Corn-

wall, born Nov. 15, 1708, and educated at Eton and Oxford. He entered parliament as member for the borough of Old Sarum (which was the property of his family), and soon attracted notice as a powerful opponent of Walpole. In spite of the king's dislike Pitt was powerful enough to win a place in the administration (1746), first as vice-treasurer of Ireland, and afterwards as paymaster-general. In 1756 he became secretary of state and real head of the government. Dismissed in 1757 on ac-



William Pitt, Earl of Chatham.

count of his opposition to the king's Hanoverian policy, no stable administration could be formed without him, and he returned to power the same year in conjunction with the Duke of Newcastle. It was under this administration and entirely under the inspiration of Pitt that Britain rose to a place amongst the nations she had not before occupied. Wolfe and Clive, both stimulated and supported in their great designs by Pitt, won Canada and India from the French, and the support the Great Commoner gave Frederick of Prussia contributed not a little to the destruction of French predominance in Europe. The accession of George III. brought Lord Bute into power, and Pitt, disagreeing with Bute, resigned in 1761. In 1766 he strongly advocated conciliatory measures towards the American colonies, and undertook the same year to form an administration, he going to the House of Lords as Earl of Chatham. But the ministry was not a success, and in 1768 he resigned. After this his principal work was his appeals for a conciliatory policy

towards the colonies. But his advice was disregarded, and the colonies declared themselves independent in 1776. Chatham died May 11, 1778. He received a public funeral and a magnificent monument in Westminster Abbey. The character of Chatham was marked by integrity, disinterestedness, and patriotism. With great oratorical gifts and the insight of a great statesman he had liberal and elevated sentiments: but he was haughty and showed too marked a consciousness of his own superiority.

**Chatham Islands**, a group of three islands in the South Pacific Ocean, belonging to New Zealand. The largest, or Chatham Island, lat. (s. point)  $44^{\circ} 7' \text{ s.}$ ; lon.  $176^{\circ} 49' \text{ w.}$ , is about 350 miles E. from New Zealand, and is about 38 miles long and 25 broad. Pitt Island is much smaller, and Rangatira is an insignificant patch. A considerable portion of Chatham Island is occupied by a salt lagoon. The soil is in many places fertile, and crops of potatoes, wheat, and vegetables are successfully grown. Cattle and sheep are reared, and thus whaling or other vessels that call are supplied with fresh provisions as well as with water. The original inhabitants, called Morioris, differed considerably from the Maoris, by whom and a mixed race they have been supplanted. The present population amounts to only 285. The islands were discovered in 1791.

**Chati** (chä'tē), a species of small leopard found in South America, very destructive to small quadrupeds and birds, and especially to poultry-yards, but so gentle, when domesticated, as to have gained for itself the name of *Felis mitis*, or gentle leopard.

**Châtillon-sur-Seine** (shä-tē-yōn-sür-sen), a town, France, department of Côte d'Or, 45 miles N.W. of Dijon, on the Seine. It is chiefly notable for the congress of the allied powers and France held here in 1814. Pop. 5265.

**Chat Moss**, an extensive morass, area about 6000 to 7000 acres, situate chiefly in the parish of Eccles, Lancashire. It is remarkable as being the scene of operations for reclaiming bog-lands first successfully carried out on a large scale in the end of last and beginning of present century; also for offering one more field of triumph to George Stephenson, who in 1829 carried the Liverpool and Manchester Railway over it after all other engineers had declared the feat impossible.

**Chatoy'ant**, a term applied to gems that have, when cut and polished, a changeable

undulating lustre like that of a cat's eye in the dark.

**Châtre** (shä-tr), LA, an old town, France, dep. Indre, 21 miles S.E. of Châteauroux, right bank of Indre. Pop. 4581.

**Chatsworth**, an estate of the dukes of Devonshire, in Derbyshire, purchased in the reign of Elizabeth by William Cavendish, who began the building of a hall which served as one of the prisons of Mary Queen of Scots. The present building was nearly completed by the first Duke of Devonshire between 1687 and 1706, the north wing being added by the sixth duke. It forms a square, with an inner court, and is remarkable for the collections of pictures and statues it contains. The façade is 720 feet long, or with the terraces 1200 feet. The park is about 11 miles in circumference, diversified by hill and dale. The conservatory covers nearly an acre, and was designed by Paxton, forming on a small scale the forerunner of the exhibition building of 1851.

**Chattahoo'chee**, a river, United States, rising in the Appalachian Mountains in Georgia, and forming for a considerable distance the boundary between Georgia and Alabama. In its lower course, after the junction of the Flint River, it is named the Appalachicola, and is navigable to Columbus in Georgia for steam-boats. Total course, about 550 miles.

**Chattanooga**, a town of the U. States, in Tennessee, on the Tennessee river, near the Georgia boundary, an important centre of trade and manufactures. During the civil war, in Oct. 1863, the Confederates here suffered a great defeat after desperate fighting. Pop. 29,109.

**Chat'tels**, property movable and immovable, not being freehold. The word *chattel* is originally the same word with *cattle*, formed from late Latin *capitalia*, meaning heads of cattle, from L. *caput*, head. Chattels are divided into real and personal. Chattels *real* are such as belong not to the person immediately, but dependently upon something, as an interest in a land or tenement, or a lease, or an interest in advowsons. Any interest in land or tenements, for example, is a real chattel; so also is a lease, an interest in advowsons, and so forth. Chattels *personal* are goods which belong immediately to the person of the owner, and include all movable property.

**Chatterers**, the popular name of certain insessorial birds of the family Ampelidæ,

genus *Ampelis*), as the Bohemian chatterer or waxwing (*Ampelis garrula*) and the chatterer of Carolina (*A. cedrorum*).

**Chat'terton**, THOMAS, a youth whose genius and melancholy fate have gained him much celebrity, was born at Bristol in 1752, of poor parents, and educated at a charity school. He exhibited great precocity, became extremely devoted to reading, and was especially fond of old writings and documents. At the age of fourteen he was apprenticed to an attorney. In 1768, when the new bridge at Bristol was completed, he inserted a paper in the Bristol Journal entitled *A Description of the Friars' First Passing over the Old Bridge*, which he pretended he had found along with other old manuscripts in an old chest in St. Mary Redcliffe Church, Bristol. He also showed his friends several poems of similarly spurious antiquity which he attributed to one Rowley. In 1769 he ventured to write to Horace Walpole, then engaged upon his *Anecdotes of Painters*, giving him an account of a number of old Bristol painters which was clever enough to deceive Walpole for a time. Dismissed from the attorney's office, he left with his manuscripts for London, where a favourable reception from the booksellers gave him high hopes. For them he wrote numerous pamphlets, satires, letters, &c., but got no substantial return, and his situation became daily more desperate. At last, after having been several days without food, he poisoned himself, 25th August 1770. The most remarkable of his poems are those published under the name of Rowley, spurious antiques, such as *The Tragedy of Ælla*, *The Battle of Hastings*, *The Bristow Tragedy*, &c.

**Chatterton's Compound**, a mixture of Stockholm tar, resin, and gutta serena, used in the construction of submarine telegraph cables, &c.

**Chau'cer**, GEOFFREY, 'the father of English poetry,' born in London probably about 1340, and not in 1328, the date formerly given; died there on the 25th of October, 1400. He was the son of a vintner named John Chaucer. Nothing is known of his education, but in 1356-59 he was a page to Princess Lionel. He tells us himself that in 1359 he bore arms in France and was taken prisoner. He was ransomed next year, the king paying £16 towards the necessary sum. In 1367 we find his name as a valet of the king's chamber. Whether he married his wife Philippa in 1366 or not till 1374, and who she was, we do not know

for certain. In 1367 he received a pension of twenty marks, and between 1370 and 1380 he was employed abroad in seven diplomatic missions. In one of these, in 1372, he was sent to Genoa as a commissioner to negotiate a commercial treaty. It is probable that he visited the Italian poet Petrarch on this occasion. In 1374 he was appointed comptroller of the customs on wool at London, a lucrative post, and he also received an annual allowance. In 1377 he was sent to Flanders and France on dip-



Geoffrey Chaucer.

lomatic business, and next year to Lombardy. In 1382 he was appointed comptroller of the petty customs. In 1386 he was returned to parliament as knight of the shire for Kent, but in the same year he shared the disgrace of his patron, John of Gaunt, was dismissed from his comptrollerships, and reduced to a state of comparative poverty. Three years later, however, he was made clerk of the works at 2s. a day, and afterwards had other offices and one or two annuities bestowed upon him, but in 1394-98 must have been quite poor. In 1399 he got a pension of forty marks from Henry IV., but did not live long to enjoy it. His most celebrated work, *The Canterbury Tales*, was written at different periods between 1373 and 1400. It consists of a series of tales in verse (two in prose), supposed to be told by a company of pilgrims to the shrine of St. Thomas (Becket) at Canterbury in 1386. In its pages we get such pictures of English life and English ways of thought in the 14th century as are found nowhere else. Besides his great work Chaucer wrote many poems

(and others are falsely attributed to him): The Book of the Duchess (1369), The Parliament of Fowls (1374), Troilus and Criseida (1380-82), The Legend of Good Women (1385), The House of Fame (1386), &c., some of which are founded on French or Italian works. He also translated Boethius, and wrote a treatise on the Astrolabe (1391) for his son Lewis (who probably died early). He was buried in Westminster Abbey.

**Chauci**, an ancient Teutonic tribe dwelling E. of the Frisians, between the Ems and Elbe on the shore of the German Ocean.

**Chaufontaine** (shōd-fon-tān), a village of Belgium, 4 miles from Liège, on the Vesdre, with hot springs much frequented in summer.

**Chaudes-Aigues** (shōd-āg), village, France, department of Cantal, 28 miles E.S.E. of Aurillac, with thermal springs so copious that the water is used for warming the town in winter and for washing fleeces. Pop. 1948.

**Chaudet** (shō-dā), ANTOINE DENIS, French sculptor, born at Paris 1763, died there 1810. His first work was a bas-relief under the peristyle of the Pantheon, representing the love of glory, an excellent work, the very simplicity and grandeur of which prevented it being justly estimated by the false taste of the age. In the museums of the Luxembourg and Trianon are several of Chaudet's finest works: *La Sensibilité*, the beautiful statue of Cyparissa, &c.

**Chaudière** (shōd-yār), a river of Canada, Quebec province, which rises on the borders of Maine, near the sources of the Kennebec, and flows into the St. Lawrence about 6 miles above Quebec. The banks of the river are generally steep and rocky, and about three miles above its junction with the St. Lawrence are the Chaudière Falls, about 120 feet high. On the Ottawa river are other two falls of lesser dimensions known as the Great and the Little Chaudière.

**Chaul'mugra**, a tree (*Gynocardia odorata*) of S. Asia, from the seeds of which an oil is obtained that has long been known and highly valued in India and China as a remedy in skin diseases and complaints arising from blood impurities, and has been introduced into western countries in the treatment both of skin and chest diseases.

**Chaumont** (shō-mōn), a town, France, capital of the department of Haute-Marne, on a height between the Marne and the Suize, with manufactures in woollens, hosiery, &c. Here the allies (Great Britain,

Russia, Austria, and Prussia) signed the treaty of alliance against Napoleon, March 1, 1814. Pop. 12,160.

**Chaumontelle** (shō-mon-tel'), a delicious dessert pear which is much grown in Jersey, Guernsey, and the south of England.

**Chauny** (shō-nē), a town, France, dep. Aisne, 19 miles W. by N. of Laon, on the Oise. It has manufactures of sacking, soda, sulphuric and nitric acids; cotton mills; bleaching grounds and tanneries. Pop. 8852.

**Chaus** (kā'us), a genus of Asiatic and African lynxes or cat-like animals, including the *Chaus Libycus*, or Libyan chaus, and the *Chaus Caffer*, or Caffre-cat. They are fond of the water, and excellent swimmers.

**Chausses** (shōs), the tight covering for the legs and body, reaching to the waist, formerly worn by men of nearly all classes throughout Europe. They resembled tight pantaloons with feet to them. The name *chausses de mailles* was given to defensive armour worn on the same parts of the body.

**Chautau'qua**, a beautiful lake in New York state, U.S., 18 miles long and 1-3 broad, 726 feet above Lake Erie, from which it is 8 m. distant. On its banks is the village of Chautauqua, the centre of a religious and educational movement of some interest. This originated in 1874, when the village was selected as a summer place of meeting for all interested in Sunday-schools and missions. Since then the Chautauqua Literary and Scientific Circle has taken origin here, the most prominent feature of which is to engage the members—wherever they may reside—in a regular and systematic course of reading, extending, when completed, over four years and entitling the student to a diploma. There are many local branches or societies, and it is attempted to start the movement in Britain.

**Chauvinism** (shō'vin-izm), an unreflecting and fanatical devotion to any cause, especially an exaggerated patriotism, so called from *Nicholas Chauvin*, a soldier so enthusiastically devoted to Napoleon I. and so demonstrative in his adoration that his comrades turned him into ridicule.

**Chaux-de-Fonds** (shōd-fōn), LA, a town of Switzerland, in the canton and 9 miles N.W. of the town of Neuchâtel, in a deep valley of the Jura. The inhabitants are largely engaged in the making of watches and clocks, of which Chaux-de-Fonds and Locle are the chief centres in Switzerland, and in similar branches of industry. Pop. 1888, 25,603.



**Chavica** (chav'i-ka), a genus of plants, nat. order Piperaceæ, including the common long pepper, Java long pepper, and betel-pepper.

**Chay-root** (shā), the roots of a small biennial plant of Hindustan, the *Oldenlandia umbellata*, growing spontaneously on dry sandy ground near the sea; and extensively cultivated, chiefly on the Coromandel coast. It yields a dye which is much used in colouring Indian cotton and chintzes.

**Cheboygan**, Mich., a town on Lake Huron; has several saw and planing mills, a bank and 2 papers. Pop. 1890, 6235.

**Check.** See *Cheque*.

**Checkers**, the common name in America for the game of draughts (which see).

**Checkmate.** See *Chess*.

**Ched'dar**, a parish and thriving village, England, county Somerset, 18 miles s.w. Bristol. The dairies in the neighbourhood have long been famous for the excellence of their cheese, which is made from the whole milk, and the whey skimmed off, heated, and added to the curd.

**Chedu'ba**, an island in the Bay of Bengal, belonging to Burmah, about 25 miles off the coast of Arracan; length and breadth, each about 15 miles; area, nearly 250 square miles; pop. 8534. The soil is fertile and produces tobacco, rice, indigo, pepper, &c. Petroleum is also found.

**Chee-Foo**, a town of China in the province of Shantung, one of the last ports opened to foreign trade, which is now of considerable volume. Pop. 32,000.

**Cheese**, one of the most important products of the dairy, is composed principally of *casein*, which exists in cows' milk to the extent of about 3 or 4 per cent, fat, and water. It is made from milk, skimmed wholly, partially, or not at all, the milk being curdled or coagulated, and the watery portion or whey separated from the insoluble curd, which being then worked into a uniform mass, salted (as a rule), and pressed in a vat or mould forms cheese, but requires to be *cured* or *ripened* for a time before being used. The coagulation of the milk may be effected either by adding an acid as in Holland, or sour milk as in Switzerland, or rennet as usual in Britain and America. There are a great many varieties of cheese, of which the most notable are Stilton, Cheshire, Cheddar, Dunlop, amongst British; and Parmesan, Gruyère, Gorgonzola, Gouda, amongst foreign ones. (See different articles.) In America immense

quantities of cheese are made, almost all the different European kinds being imitated. Large factories are there devoted to the manufacture. Other kinds are known as sour-milk, skimmed-milk, cream, sweet-milk, &c., cheese. Sheep's and goat's milk cheese are also made.

**Cheese-fly**, a small black dipterous insect bred in cheese, the *Piophilæ casei*, of the same family to which the house-fly, blow-fly, &c., belong. It has a very extensible ovipositor, which it can sink to a great depth in the cracks of cheese, and lay its eggs there. The maggot, well known as the cheese-hopper, is furnished with two horny claw-shaped mandibles, which it uses both for digging into the cheese and for moving itself, having no feet. Its leaps are performed by a jerk, first bringing itself into a circular attitude, when it can project itself twenty to thirty times its own length.

**Cheese-hopper.** See *Cheese-fly*.

**Cheese-rennet**, a popular name of the plant *bedstraw*.

**Cheetah.** Same as *Chetah*.

**Chefoo.** See *Chee-Foo*.

**Cheilognatha** (kī-log'na-tha), one of the two orders of Myriapoda, including the millipeds and other forms.

**Cheilopoda** (kī-lop'o-da), one of the two orders of Myriapoda, represented by the centipeds, in which a pair of mandibles, two pairs of maxillipeds or foot-jaws, and a lower lip are developed.

**Cheiranthus** (kī-ran'thus), the wall-flower genus of plants.

**Cheirolepis** (kī-rol'e-pis), a genus of fossil ganoid fishes found in the Old Red Sandstone of Orkney and Morayshire, characterized by the great development of the pectoral and ventral fins.

**Cheirromancy** (kī'ro-), or PALMISTRY, the art of divining by inspection of the lines of the hand; it was practised in India in the remotest ages; in Europe, during the middle ages, it was in great repute, but latterly it took refuge among the gypsies, who to this day find profit in the exercise of their favourite art.

**Cheirromys** (kī'ro-mis). See *Aye-aye*.

**Cheiron** (kī'ron). See *Chiron*.

**Cheironectes** (kī-rō-nek'tēz), a genus of acanthopterygious fishes, having the pectoral fins supported, like short feet, upon peduncles, by means of which they are enabled to creep over mud and sand when left dry by the receding tide, and also to take short leaps like a frog, whence the name frog-

fish, as well as hand-fish. They are found in the estuaries of the north-east of Australia.—The same name belongs to a Brazilian genus of opossums, in which the hinder-hands are webbed, the Yapock opossum.

**Cheiroptera** (kī-rop'te-ra), or BATS, an order of mammals, the essential character of which is the possession of a *patagium*, or expansion of the integument of the body which connects the tail throughout its whole length to the hinder limbs as far as the ankle, and thence passes along the side of the body to the fore-limbs, which are greatly elongated, and give support and varied movement to the expansion (which is popularly called the wing) by means of the very long and slender digits. Other mammals, as some of the squirrels and the flying lemur, have the power of gliding through the air for some distance, but none of them have the power of sustained flight, nor are the anterior extremities modified in the same way as are those of the bats. The Cheiroptera are divided into two sub-orders, *Frugivōra*, or Fruit-eaters, and *Insectivōra*, or Insect-eaters. (See *Bat*.)

**Cheirotherium** (kī-rō-thē'ri-um), a name given to a great unknown animal that formed the larger footsteps upon the slabs of the Trias, or upper New Red Sandstone, and which bear a resemblance to the human hand. It is supposed to be identical with the labyrinthodon.

**Cheke**, SIR JOHN, an English scholar, born at Cambridge in 1514, educated at St. John's College, and made regius professor of Greek. In 1544 he was appointed tutor to the future Edward VI., and appears likewise to have assisted in the education of the Princess Elizabeth. On the accession of Edward he received substantial signs of favour, was knighted, became secretary of state in 1553, and was also a privy-councillor. On the king's death he supported Lady Jane Grey, and was committed to the Tower. After a few months, however, he was set at liberty and settled in Strasburg; but his connection with the English Protestant church there gave offence to the Catholics in England, and his estates were confiscated. He supported himself by teaching Greek, but in 1556, having been induced to visit Brussels, he was arrested by order of Philip II. and sent prisoner to England. Under threat of the stake he recanted, and received the equivalent of his forfeited estates; but he felt so keenly his degradation that he died of grief in 1557. His chief distinction was

the impulse given by him to the study of Greek.

**Che-kiang**, a maritime province, China, between lat. 27° and 31° N., and including the Chusan Archipelago; area, 39,150 sq. miles; pop. 11,588,692. It is traversed by the Grand Canal, and has as its principal ports Ningpo and Hangchow, the capital. Staple exports, silk and tea.

**Chelæ** (kē'lē), the large prehensile claws of crabs and other crustaceans, or of the scorpions.

**Chelidonium** (kel-). See *Celandine*.

**Chelmsford**, county town of Essex (to a parl. div. of which it gives name), England, in a valley between the Chelmer and Cann, with several handsome public buildings. There are manufactories of agricultural implements, and a considerable trade in corn, malt, &c. Pop. 1891, 11,008.

**Chelmsford**, LORD, THE RT. HON. FREDERIC AUGUSTUS THESIGER, eldest son of the first Lord Chelmsford, who was twice lord-chancellor; born 1827, educated at Eton, served in the Crimea and through the Indian mutiny. As deputy adjutant-general he served in the Abyssinian campaign, was nominated C.B., made aide-de-camp to her Majesty, and adjutant-general to the forces in India (1868-76), and in 1877 was appointed commander of the forces and lieutenant-governor of Cape Colony. He restored Kaffraria to tranquillity, and was given the chief command in the Zulu war of 1879. After great difficulties with the transport, and some disasters, he gained the decisive victory of Ulundi, before the arrival of Sir Garnet Wolseley, who had been sent to supersede him. On his return to England he was made G.C.B., and in 1884 became lieutenant of the Tower.

**Chelonians** (ke-lō'-), or CHELONIA, an order of reptiles including the tortoises and turtles, and distinguished by the body being inclosed in a double shell, out of which the head, tail, and four legs protrude. The order is divided into five families: the Chelididæ, or frog-tortoises; Testudinidæ, or land-tortoises; Emydæ, the terrapins or fresh-water tortoises; Trionychidæ, the mud-turtles or soft-tortoises; Chelonidæ, or sea-turtles. See *Tortoise*, *Turtle*.

**Chelsea** (chel'sē), a suburb of London, and a parliamentary borough, on the Thames, opposite Battersea, and chiefly distinguished for containing a royal military hospital, originally commenced by James I. as a theological college, but converted by Charles II.

for the reception of sick, maimed, and superannuated soldiers. The building was finished in 1692 by Sir Christopher Wren. Connected with the hospital is a royal military asylum, founded in 1801, for the education and maintenance of soldiers' children. The parliamentary borough returns one member. Pop. 1891, 96,272.

**Chelsea**, a city of Massachusetts, U.S., forming a N.E. suburb of Boston. (See *Boston*.) Pop. 27,909.

**Cheltenham** (chel'tn-am), a municipal and parliamentary borough and fashionable watering-place in England, in the county of Gloucester, beautifully situated on the small river Chelt, within the shelter of the Cotswold Hills. It grew rapidly into a place of fashionable resort after the discovery of its saline, sulphuric, and chalybeate springs in 1716, to which, in 1788, George III. paid a visit. The town has fine squares, crescents, terraces, gardens and drives, pump-rooms, assembly-rooms, theatre, &c., and has of late become especially distinguished as an educational centre. The proprietary college for boys, and the ladies' college, are both of high repute, and there are also a grammar-school and a training college for teachers. The parish church and the Roman Catholic and Congregational churches are all fine buildings. The town has little trade, but depends almost wholly on its visitors and resident families. It returns one member to parliament. Pop. 1891, 42,914.

**Chemical Rays**, a not very appropriate name given to the blue and violet rays of the spectrum, and also the non-luminous rays at the violet end of the spectrum, which have a peculiarly powerful chemical effect on silver compounds.

**Chemistry**, the science which treats of the nature, laws of combination, and mutual actions of the minute particles of the different sorts of matter composing our universe, and the properties of the compounds they form. As a science it is entirely of modern origin, in its earliest phases being identical with alchemy (which see), the great object of which was the discovery of the philosopher's stone. In this pursuit most minerals, especially such as presented the characters of metallic ores, were subjected to numerous experiments, and many important isolated discoveries were made by Basil Valentine, Raymond Lully, Paracelsus, Van Helmont, and others. But during the latter part of the 17th century the belief in alchemy was greatly on the wane, and just at its close

the German chemist Becher threw out certain speculations regarding the cause of combustion, which were afterwards taken up and extended by Stahl in the 'phlogistic theory,' and constitute the first generalization of the phenomena of chemistry, though the theory itself was diametrically opposed to the truth. About the middle of the last century Dr. Black made his great discovery of a gas differing from atmospheric air, rapidly followed by that of a number of other gases by Cavendish, Rutherford, Priestley, Scheele, &c.; and the discovery of oxygen by the two last-named chemists afforded to Lavoisier the means of revolutionizing and systematizing the science. By a series of experiments he showed that all substances, when burned, absorb oxygen, and that the weight of the products of combustion is exactly equal to that of the combustible consumed and of the oxygen which has disappeared. The application of this theory to the great majority of the most important chemical phenomena was obvious, and the Stahlian hypothesis disappeared from the science. A yet more important step was the discovery by Dalton of the laws of chemical combination. His theory was immediately taken up by Berzelius, to whose influence and careful determination of the chemical equivalents of almost all the elements then known, its rapid adoption was mainly due. To Berzelius we owe almost all the modern improvements in the methods of analysis, and to Sir H. Davy the foundation of electro-chemistry. Of late years every branch of the science has advanced, but the most extraordinary progress has been made in organic chemistry. The investigations of chemists have shown that the great majority of the different substances found at the surface of the earth can be broken up into several substances of less complicated nature, which resist all further attempts to decompose them, and appear to consist of only one kind of matter. These substances, by union of which all the different sorts of known matter are built up, are about seventy in number, and are called the *chemical elements*. The list (given below) includes such substances as gold, iron, oxygen, hydrogen, carbon, calcium, &c. When any two or more of these elements are brought in contact, under the proper conditions, they may unite and form chemical compounds of greater or less complexity, in which the constituents are held in union by a form of

## CHEMISTRY.

energy which has received the name of chemical affinity. This affinity is characterized by its acting between dissimilar particles, and producing a new kind of matter, readily distinguishable from either of the substances combining to form it, and which cannot be again separated into its elements by merely mechanical processes.

*Laws of Combination.*—(1) Chemical combination takes place between the smallest particles of matter and at inappreciable distances. Thus fragments of phosphorus and iodine may be placed near each other, but do not combine until brought into actual contact. (2) Chemical combination invariably effects a change in all bodies. There are changes of state, temperature, colour, volume, taste, smell, &c. (3) Chemical combination takes place with different degrees of force in different bodies. The more unlike two bodies are they combine with greater violence. (4) Chemical combination is much affected by other forces. Heat, light, electricity, mechanical force, &c., may either accelerate or retard chemical combination. (5) All substances, elementary and compound, combine together in fixed and definite proportions by weight. (6) When bodies combine in more than one proportion their other combining proportions are simple multiples of the lowest. Thus, 28 parts of nitrogen combine with 16 parts of oxygen to form nitrous oxide, while 28 parts of the former and 32 of the oxygen produce nitric oxide, and an additional 16 of oxygen forms nitric trioxide, &c. (7) Gases combine in fixed and definite proportions by volume as well as by weight. If one volume of each gas be combined together, two volumes of the gaseous compound result. If more than one volume of each combine together, the new compound only occupies two volumes, however great the aggregate number of volumes is before combination takes place. (8) The combining proportions of compounds are the sum of the combining proportions of their constituent elements.

The *atomic weight* of any element is now assumed to be the smallest quantity which can enter into or be expelled from combination, one part of hydrogen being taken as the standard. The following table contains a list of the elements with their atomic weights and symbols (the latter being explained in a succeeding paragraph). The list might have been increased by several other elementary substances, either quite unimportant or as yet imperfectly known:—

Aluminium .. Al	27·34	Molybdenum Mo	92·00
Antimony.... Sb	122·00	Nickel .....	Ni 58·16
Arsenic..... As	75·00	Niobium.... Nb	97·50
Barium..... Ba	137·00	Nitrogen.... N	14·01
Bismuth.... Bi	210·34	Osmium..... Os	199·00
Boron..... B	10·90	Oxygen..... O	15·96
Bromine.... Br	79·75	Palladium... Pd	106·48
Cadmium.... Cd	112·24	Phosphorus.. P	31·00
Cæsium..... Cs	133·00	Platinum.... Pt	197·12
Calcium..... Ca	40·00	Potassium... K	39·13
Carbon..... C	12·00	Rhodium.... Ro	104·32
Cerium..... Ce	92·00	Rubidium... Rb	85·36
Chlorine.... Cl	35·37	Ruthenium... Ru	104·20
Chromium... Cr	52·48	Scandium... Sc	44·90
Cobalt..... Co	59·99	Selenium.... Se	79·40
Columbium.. Cb	94·00	Silicon..... Si	28·00
Copper..... Cu	63·50	Silver..... Ag	107·94
Didymium... D	96·00	Sodium..... Na	23·05
Erbium..... E	166·00	Strontium... Sr	87·50
Fluorine.... F	19·00	Sulphur..... S	32·07
Gallium.... Ga	69·86	Tantalum... Ta	138·00
Glucinium... G	9·30	Tellurium... Te	128·30
Gold..... Au	196·66	Terbium.... Tb	148·00
Hydrogen... H	1·00	Thallium.... Tl	204·00
Indium..... In	113·00	Thorium.... Th	115·70
Iodine..... I	126·53	Tin..... Sn	118·00
Iridium.... Ir	197·12	Titanium.... Ti	50·34
Iron..... Fe	56·11	Tungsten.... W	184·00
Lanthanium.. La	92·00	Uranium.... U	240·16
Lead..... Pb	206·91	Vanadium... V	52·50
Lithium..... L	7·00	Ytterbium... Yt	172·50
Magnesium.. Mg	24·32	Yttrium.... Y	61·70
Manganese.. Mn	55·00	Zinc..... Zn	65·00
Mercury.... Hg	200·00	Zirconium... Zr	89·50

*Nomenclature.*—The names employed by the old chemists were generally derived from some property of the body or indicated the mode in which it was prepared, and sometimes the substance from which it was obtained. Soon after the introduction of Lavoisier's system the French Academy of Sciences appointed a committee to improve it; and the chief merit of the one introduced is due to Guyton Morveau. Though somewhat modified to suit the requirements of modern science, it still remains substantially what it was. The names applied to the elements were as far as possible derived from some conspicuous property they possess; *e.g.* chlorine, from Greek *chlōros*, yellow. An attempt has been made to make the name express also the class to which the substance belongs. Thus all the metals (except those long known) are made to terminate in *um*, as potassium, barium, &c.; and the substances allied to chlorine have a similar termination to it. The nomenclature of compounds was based on the existence of two classes of substances opposed to one another in their properties, and known as *acids* and *bases*. All the bases known at the close of the last century were oxygen compounds, and they were known by the general name of *oxides*. The compounds of chlorine, iodine, and bro-

nine, and subsequently those of sulphur, carbon, boron, and silicon, though really belonging to a different class, were called chlorides, iodides, bromides, sulphides, &c. After the atomic theory came into use, the term oxide was confined to a compound containing one atom of oxygen in combination with one of the other element. The compound containing two atoms of oxygen became a binoxide, that with three a teroxide, and so on; the numeral prefix always expressing the number of atoms of oxygen. So also we speak of a protochloride and bichloride, a protosulphide and bisulphide. So also there are a number of oxides containing two equivalents of metal to three of oxygen; such compounds are called sesquioxides. Names constructed in this way are extremely definite, and express very precisely the constitution of the compounds; but of late years it has been found preferable to use names of less precision, and to distinguish only between the larger and smaller proportions of oxygen. Thus, there are two oxides of iron possessing basic properties, which are called respectively ferrous and ferric oxide, the termination in *ous* being used in all cases for the compound containing the smaller, and that in *ic* for the one containing the larger quantity of oxygen, the Latin name of the element being usually employed. Both systems, however, are still in common use, and each has its special advantages. The nomenclature for compounds possessing acid instead of basic properties, has its origin in part in the belief entertained by chemists in the last century that all acids were oxygen compounds, and that it was therefore unnecessary to indicate the existence of oxygen in them, as the word acid sufficiently did so. Thus sulphur forms two different acid compounds, one with a smaller proportion of oxygen than the other, called respectively sulphurous and sulphuric acids; and similarly we have chlorous and chloric acids, &c. The contrivers of the present nomenclature did not provide for more than two acid compounds of any one element, that being the largest number then known. But since that time it has been found that there may be four or five such compounds necessitating the use of a distinctive prefix, as in the case of hyposulphurous and hypsulphuric acids, the prefix (from Greek *hypo*, under) expressing the fact that they contain smaller quantities of oxygen than the other acids. In the case of chlorine and oxygen, after the name chloric acid had been made

use of, another acid containing a larger quantity of oxygen was discovered, for which the name of hyperchloric acid, usually shortened into perchloric acid, was devised. Further observation, however, showed that there were many powerful acids which contained no oxygen, but that hydrogen was invariably present, and it became necessary to distinguish those which contained hydrogen only. Accordingly we have hydrochloric acid, a compound of hydrogen and chlorine, in contrast with chloric acid, a compound of hydrogen, chlorine, and oxygen; and hydrosulphuric acid, a compound of hydrogen and sulphur, in contrast with sulphuric acid, a compound of hydrogen, sulphur, and oxygen.

The names of acids were formed in order to enable chemists to have simple designations for *salts*, a class of bodies produced when a metal takes the place of the hydrogen of an acid. Thus the termination in *ate* expressed the fact that the salt is derived from an acid whose name terminates in *ic*, and the salts of acids whose names end in *ous* have their termination in *ite*. Very frequently two salts, generally of the same acid, combine to form what is usually known as a double salt, as, for instance, potassium sulphate and zinc sulphate combine, and the compound is called the zinco-potassic sulphate.

This system of nomenclature, which fulfilled the requirements of chemistry at the time it was devised, became less and less convenient as more complex compounds were discovered, and many attempts have been made to modify and extend it. These attempts, however, have uniformly failed to meet the approval of chemists.

*Symbols.*—Very soon after the publication of Dalton's views Berzelius introduced a system of symbols by which the composition of the more complex chemical compounds can be represented with much greater precision than any nomenclature admits of; and the plan proposed by him, though with some modifications, is now universally accepted. Every element is represented by a symbol, which is the initial letter of its Latin name. Thus S represents sulphur, and K potassium, of which the Latin name is *kalium*. Where several elements have the same initial a small letter is attached to it for the sake of distinction. Thus, C is the symbol of carbon, Ca that of calcium, Ce cerium, Co cobalt, and Cu copper (*cuprum*). These symbols are further understood in all cases to represent an atom of each element. The

symbols of compounds are formed by the juxtaposition of those of their elements. Thus—

H Cl, ..... Hydrochloric acid,  
Ba S, ..... Baric sulphide,

express the fact that these compounds contain single atoms of their constituents; that hydrochloric acid, for example, is a compound of 1 part of hydrogen and 35.5 of chlorine; and baric sulphide of 137 parts of that metal and 32 of sulphur. When more than one atom of an element exists in any compound this is indicated by a co-efficient placed after its symbol. Thus H<sub>2</sub>O is a compound of two atoms of hydrogen and one of oxygen; SO<sub>3</sub>, a compound of one atom of sulphur and three of oxygen; Fe<sub>2</sub>Cl<sub>6</sub>, a compound of two atoms of iron and six of chlorine. Where it is necessary to express more than one atom or molecule of the compound this is done by prefixing to the symbol a large number written on the line. Thus 2 BaCl<sub>2</sub> means two molecules of baritic chloride; 3 Fe<sub>2</sub>O<sub>3</sub>, three molecules of ferric oxide. By a systematic arrangement of the symbols in each compound an attempt is made to indicate to a certain extent their chemical functions. Thus, in an acid, the hydrogen, which may be replaced by a metal, begins the formula of the compound; sulphuric acid, for instance, is written H<sub>2</sub>SO<sub>4</sub>, and potassic sulphate K<sub>2</sub>SO<sub>4</sub>, the potassium here occupying the same position as the hydrogen it has displaced.

The symbols are also very advantageously used to express the changes which occur during chemical action, and they are then written in the form of an equation, of which one side represents the condition in which the substances exist before the change, the other the result of the reaction. Thus—

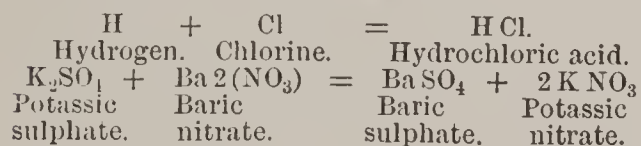

*Atomicity.*—When an atom of chlorine, weighing 35.5, is brought in contact with hydrogen it is found to combine only with one atom of that substance. When an atom of oxygen, weighing 16, comes in contact with hydrogen, however, it combines with two parts, or two atoms, of that element. An atom of nitrogen, weighing 14, combines only with three parts or three atoms of hydrogen. These elements are therefore said to possess different *atomicities*;

hydrogen is called a *monatomic element*, oxygen *biatomic*, and nitrogen *triatomic*. With reference to this fact, therefore, the elements have been divided into several classes according to the number of atoms of hydrogen to which they are equivalent, or with which they can combine, and they are described as monads, diads, triads, &c. No physical explanation of the cause of this peculiarity of the different elements has yet been obtained. The idea which is made use of is that the atoms of the elements have certain points of attachment with one another, varying in number in each case. A monad is supposed to have one point of attachment, a diad two, and so on, and these have been called *bonds*. A diad, therefore, having two bonds or points of attachment, is capable of assimilating, as it were, two monads, a triad three monads. This may be represented diagrammatically by using a small circle for each atom, with one or more lines projecting from its side, according to the number of bonds or points of attachment which belong to each. More commonly, such compounds are represented by lines surrounding the ordinary symbol of the element; but as such symbols are very inconvenient in writing and printing, it is customary to express the atomicity of an element or compound by dashes attached to its ordinary symbol. Thus, monad hydrogen is H', diad oxygen O'', triad nitrogen N'''; and when the atomicity exceeds three a small Roman numeral is employed, thus, tetratomic carbon is C<sup>iv</sup>. Experience has further shown that the atomicity of an element is capable of varying, but that the change of atomicity invariably takes place by pairs. A pentatomic element may become triatomic or monatomic, but never tetratomic or biatomic; and a tetratomic may become biatomic, but never triatomic or monatomic. This variation in atomicity has been accounted for by supposing that two atomicities in an element can neutralize or saturate one another.

*Molecules.*—The molecule of a compound is the quantity of it which exists in two gaseous volumes, so that we do not speak of the atom of a compound, but of its molecule, that being the smallest quantity of a compound which can be obtained in the separate state. This and other considerations have led to the further hypothesis, that *atoms* never exist in a separate state, but that, as soon as they are separated from compounds, they enter into combination with one an-

other. A molecule of hydrogen is therefore  $H_2$ , or it may be represented thus  $H-H$ , so as to indicate that the two hydrogen bonds saturate one another.

*Compound Radicals.*—In every perfect molecule all the bonds of the elements which combine are saturated, and the affinities being perfectly satisfied, the molecule has no disposition to combine directly with any other substance; but if several elements are combined in such a manner that one or more bonds remain unsatisfied, the compound so produced has in general very powerful affinities, and unites readily with any substance capable of saturating its uncombined bond. The tetratomic carbon, for example, by uniting with four atoms of hydrogen, forms the saturated molecule  $CH_4$ ; but when carbon unites with only three atoms of hydrogen, a group,  $CH_3$ , is produced, containing one unsaturated bond which is capable of combining with other substances, such as chlorine, iodine, or bromine. Such a group as  $CH_3$  is called a *compound radical*. Radicals of this kind are capable of forming a variety of compounds, in which their functions resemble those of an element, and viewed in this aspect an element has often been called a simple radical. A compound radical may be monad, diad, &c., according to the number of unsaturated bonds it contains.

*Classification of Compounds.*—The properties of chemical compounds may be classified not merely under the head of the particular elements they contain, but also according to their special chemical functions. The advantages of the latter method were early recognized, and the distinction between *acids* and *alkalies* dates back to a period long previous to the ascertainment of their true nature. These, and the class of *salts* which are produced by the mutual action of an acid and a base, are the most important classes of chemical compounds. An acid is now described as a compound containing a certain quantity of hydrogen, easily replaceable by a metal when it comes in contact with it either in the free state or as an oxide.

*Bases* are compounds which, by reacting on acids, yield salts. The most important bases are oxides of metals, and they are divided into several sections, of which the most important are the alkalies. These substances are the hydrates of the so-called alkaline metals, and may be compared to water in which an atom of hydrogen is re-

placed by an atom of metal. Most of the bases, excepting the alkalies, are insoluble in water, and without any effect on vegetable colours. Another class of bases of great importance is typified by ammonia.

*Sulphides* are compounds of the metals with sulphur, and form a very important class of compounds. They are obtained either by heating the metals with sulphur in proper proportions, or by passing a current of hydrosulphuric acid gas through a solution of a salt. They exist abundantly in the mineral kingdom, and form some of the most important ores. Some of the sulphides are capable of acting as bases and others as acids, and by combination a class of salts, usually distinguished as sulphur salts, can be obtained. The greater part of the sulphides are insoluble in water, and some of them possess extremely fine colours, and are used as paints.

*Organic and Inorganic Chemistry*—Organic chemistry is that branch of the science which treats of the compounds existing in plants and animals, or which may be produced from substances found ready formed in their tissues. It was at first believed that these compounds were peculiar in their constitution, quite distinct in their chemical relations, and produced by what was called vital affinity. The discovery by Wöhler, however, that urea could be produced artificially from purely mineral substances entirely altered this view; and since then the artificial production of many organic compounds has practically annulled the distinction between organic and inorganic chemistry except as a matter of convenience. Organic chemistry is now most commonly defined as the chemistry of the carbon compounds, for that element is found in every substance which can be extracted from plants and animals, in combination with hydrogen, oxygen, nitrogen, and less frequently with sulphur and phosphorus. These elements are so combined as in many cases to form compounds of extreme complexity, the constitution of some of which is still a matter of much difference of opinion among chemists; but the constitution of the simpler organic compounds is now thoroughly understood.

*Chemists*, those who keep shops for the sale of drugs. In Britain pharmaceutical chemists are all those who, after passing the necessary examinations, are registered as such by the Pharmaceutical Society. This society was incorporated by royal charter in

1843, and its character was confirmed and its constitution modified by the act of 1852. By the Pharmacy Act of 1868 all persons who are not duly registered are forbidden under a penalty to keep open shop to retail, dispense, or compound poisons, or to use the title of chemist, druggist, pharmacist or pharmacist, or pharmaceutical druggist. The act, however, does not interfere with the business of any legally-qualified apothecary, nor of any member of the Royal College of Veterinary Surgeons of Great Britain, nor with the making and dealing in patent medicines. See *Druggist*.

**Chemnitz** (*hem'nits*), the principal manufacturing town in the kingdom of Saxony, on the Chemnitz, 39 miles south-west of Dresden. It is well built, and has a castle, a lyceum, town-hall, school of design, &c. The principal manufactures are white and printed calicoes, ginghams, handkerchiefs, woollen and half-woollen goods, &c. There are also extensive cotton-spinning mills, and mills for the spinning of combed wool and floss-silk; dye-works, print-works, bleach-works, chemical works; large manufactures of cotton hose, &c. The manufacture of machinery also has now become important. The cotton hose and woollen goods are exported to Japan, China, Africa, and America, while the machinery is chiefly destined for Russia, Silesia, and Bohemia. Pop. 1890, 138,955.

**Chemnitz** (*hem'nits*), MARTIN, a German Protestant theologian of the 16th century, born in the mark of Brandenburg in 1522. He was educated at Wittenberg and became a schoolmaster in Wriezen on the Oder. In 1550 he became librarian of Duke Albert of Prussia, and about this time wrote his *Loci Theologici*, 1591, a learned commentary on Melancthon's system of dogmatics. He subsequently went as a minister to Brunswick, where he died in 1586. Of his other works the most valuable is the *Examen Consilii Tridentini*.

**Chemosh** (*kē'mosh*), the national god of the Moabites, who were on that account called 'the people of Chemosh' (Num. xxi. 29; Jer. xlviii. 46). At an early period the same deity appears too as the national god of the Ammonites (Judg. xi. 24), though his worship seems afterwards to have given place to that of Moloch (1 Ki. xi. 5, 7), if Moloch be not merely another name for the same deity. The worship of Chemosh was even introduced among the Hebrews by Solomon, who 'built an high place for

Chemosh, the abomination of Moab, in the hill that is before Jerusalem' (1 Ki. xi. 7).

**Chemosis** (*kē-mō'sis*), an affection of the eye, in which the conjunctiva is elevated above the transparent cornea.

**Chemulpo** (*chē-mul'pō*), one of the three treaty-ports of Corea, exporting beans, ginseng, &c., and importing European and American manufactures.

**Chenab** (*chen-áb'*), a river of Hindustan, one of the five rivers of the Punjab. It rises in the Himalayan ranges of Kashmir, and entering the Punjab near Sialkot, flows in a south-westerly direction till it unites with the Jehlam; length about 800 miles. At Wazirabad it is crossed by a great iron railway bridge more than a mile long.

**Cheng**, a Chinese musical instrument, consisting of a series of tubes having free reeds. Its introduction into Europe led to the invention of the accordion, harmonium, and other free-reed instruments.

**Chénier** (*shā-nyā*), ANDRÉ-MARIE DE, a French poet, born at Constantinople in 1762, went to France when very young, and entered the army, but left shortly after his twentieth year to devote himself to literary pursuits. In 1790 he joined the moderate section of the Republicans, and made himself offensive alike to the Royalists and Jacobinical party. Being brought before the revolutionary tribunal he was condemned and guillotined 25th July, 1794. The poems of Chénier are inconsiderable in number, but give the author a high place amongst the poets of France. His chief works are *Hermes*; *The Elegies*; *La Liberté*, &c.; and some beautiful odes, of which *La Jeune Captive*, written in prison, is perhaps the best known.

**Chénier**, MARIE JOSEPH BLAISE DE, brother of the foregoing, born Aug. 28, 1764, at Constantinople, went when very young to Paris, served as an officer of dragoons, left the service, and devoted himself to literary pursuits. His dramas *Charles IX.*, *Henry VIII.*, *La Morte de Calas*, full of wild democratic declamation, were received with great applause. He was chosen a member of the Convention, where, for a considerable time, he belonged to the party of the most violent Democrats. His works comprise discourses on the history of French literature, as well as odes, songs, hymns, &c. He died in January, 1811.

**Chenille** (*she-nil'*), a sort of ornamental fabric of cord-like form, made by weaving or twisting together warp-threads, with a



transverse filling or weft, the loose ends of which project all round in the form of a pile. Chenille carpets have a weft of chenille, the loose threads of which produce a fine velvety pile.

**Chénonceaux** (shā-noṅ-sō). See *Bléré*.

**Chenopodia'ceæ** (kē-), a nat. order of apetalous exogens, consisting of more or less succulent herbs or shrubs, belonging to about eighty genera and 600 species. They are mostly innocent weeds, but several are employed as pot-herbs, such as spinach and beet, and others for the manufacture of soda. The genus *Chenopodium* consists of weedy plants, common in waste places, and known in Britain by the names of goosefoot, fat-hen, good King Henry, &c. *C. anthelminticum* is a species well known in the U. States, where it is in repute as a vermifuge, under the name of wormseed, the seeds or the oil obtained from them being given as a remedy for worms. *C. Quinoa* is an important S. American species, having edible seeds, on account of which it is largely cultivated in Peru and Chili as a food-plant.

**Cheops** (kē'ops), the name given by Herodotus to the Egyptian despot whom the Egyptians themselves called Khufu. He belonged to the rulers who had for their capital Memphis; lived about 2800–2700 B.C., and built the largest of the pyramids. According to Herodotus he employed 100,000 men on this work constantly for 20 years.

**Chephren** (kef'ren), or CEPHREN, was the successor of Cheops as king of Egypt, and the builder of the second pyramid. His name is properly Khafra. See *Cheops*.

**Chep'stow**, a town and port in England, county Monmouth, on the Wye, 14 miles N. by W. of Bristol. The high tides of the Wye allow large ships to reach the town, which is very ancient, and has a castle, portions of which date back to the Conquest. Pop. 1891, 3378.

**Cheque**, or CHECK, a draft or bill on a bank payable on presentation. A cheque may be drawn payable to the bearer, or to the order of some one named: the first form is transferable without endorsement, and payable to any one who presents it; the second must be endorsed, that is the person in whose favour it is drawn must write his name on the back of it. Cheques are a very important species of mercantile currency wherever there is a well-organized system of banking. The regular use of them for all

payments, except of small amount, makes the transfer of funds a mere matter of cross-entries and transferring of balances among bankers, and tends greatly to economize the use of the precious metals as a currency. What is called a 'crossed cheque' has two lines drawn across it transversely, with or without the words '& Co.' between. A cheque thus marked can only be paid by the banker on whom it is drawn when presented by some other banker, and the person to whom it is sent can consequently only obtain payment of it through his own bankers. Such cheques are not used in the U. S. Checks drawn payable to order or bearer must have one 2-cent revenue stamp attached or impressed.

**Chequy**, or CHEQUERED. See *Heraldry*.

**Cher** (shār), a river of Central France, a tributary of the Loire, which it enters near Tours; length, 200 miles.

**Cher** (shār), a department of Central France, named from the river Cher, and formed from part of the old provinces of Berry and Bourbonnais; area, 2779 square miles; capital, Bourges. The surface is in general flat, but is diversified in the N. by chains of inconsiderable hills. Soil various, but fertile in the neighbourhood of the Loire and Allier. The forests and pastures are extensive. More grain and wine are produced than the demands of the inhabitants require. The preparation and manufacture of iron, called Berry-iron, is the principal branch of industry. The department is divided into three arrondissements. Pop. 1891, 359,276.

**Cherbourg** (shār-bör), a fortified seaport and naval arsenal of France, in the department of La Manche, 196 miles W.N.W. Paris. The fortifications are very extensive, and have been greatly strengthened in recent years, so that Cherbourg, if not impregnable from the sea, is at least very difficult of attack. The port is divided into the commercial and naval ports, which are quite distinct. The Port Militaire is accessible at all times of tide for vessels of the largest class; there are slips for vessels of the largest dimensions, dry docks, building-sheds, mast-houses, boiler-works, and in short everything necessary for the building and fitting out of ships of war. There is a great *digue* or breakwater, stretching across the roadstead, which, though protected on three sides by the land, was formerly open to the heavy seas from the north. The *digue* was commenced under Louis XVI., is 4120 yards long, and is 2½ miles from the harbour, in

CHERBURY — CHERRY.

water varying from 42 to 62 feet deep. A fort and lighthouse occupy the centre of the *digue*, and there are circular forts at the extremities. The principal industry of the town is centred in the works of the dock-yard, the commercial trade and manufac-

tures being comparatively insignificant. Large quantities of eggs are shipped for England. Cherbourg occupies the site of a Roman station. William the Conqueror founded an hospital in it, and built the castle church. The castle, in which Henry II.

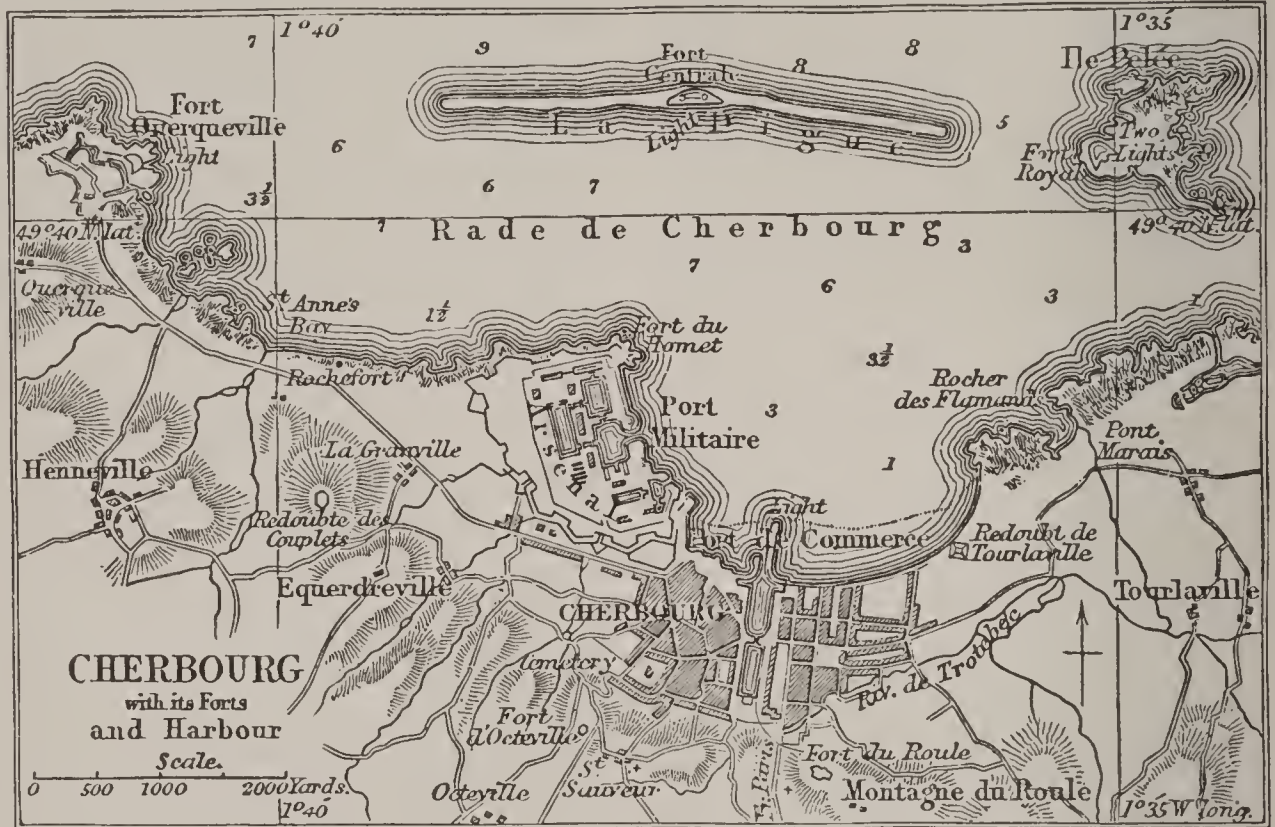

frequently resided, was one of the strongholds of Normandy. The town was taken by the British in 1758. Pop. 1891, 38,554.

**Cherbury, LORD.** See *Herbert, Edward*.

**Cheribon** (sher'i-bon), a seaport in the island of Java, capital of the province of the same name. The province lies on the coast towards the N.W., produces coffee, timber, areca-nuts, indigo, and sugar, and has about 770,000 inhabitants. The town lies in a deep bay on the north coast, and is the residence of a Dutch governor. Pop. 11,000.

**Cherimoy'er** (cher-), the fruit of the *Anōna Cherimolia*, a native of S. and Central America, allied to the custard-apple. It is a heart-shaped fruit with a scaly exterior, and numerous seeds buried in a delicious pulp. Both flowers and fruit emit a pleasant fragrance. This fruit is now cultivated in various tropical regions.

**Cherkask'.** See *Tcherkask*.

**Cher'nigov.** See *Tchernigov*.

**Cherokees'**, a tribe of North American Indians in the United States, occupying an allotted region in the Indian Territory. Their old seats were in Georgia, Alabama,

Mississippi, and Tennessee. The Cherokees are the most enlightened of the Indian tribes, have invented an alphabet, printed books and newspapers in their own language, live in well-built villages, and have an excellent school system. Their numbers are about 20,000.

**Cheroot** (she-röt'). See *Cigar*.

**Cherry**, a fruit-tree of the prune or plum tribe, very ornamental and therefore much cultivated in shrubberies. It is a native of most temperate countries of the northern hemisphere, and in Britain is quite common in the wild state, besides being cultivated for its fruit. The cultivated varieties probably belong to two species, *Cerāsus avium* and *Cerāsus vulgāris*, the genus *Cerasus* being considered a sub-genus of *Prunus*. They are numerous, as the red or garden cherry, the red heart, the white heart, the black cherry, &c. The fruit of the wild cherry, or *gean*, is often as well flavoured, if not quite so large, as that of the cultivated varieties. It is said that this fruit was brought from *Cerasus*, in Pontus, to Italy, by Lucullus, about B.C. 70, and introduced

into England by the Romans about A.D. 46. The cherry is used in making the liqueurs Kirschwasser and Maraschino (which see). The wood of the cherry-tree is hard and tough, and is very serviceable to turners and cabinet-makers. An ornamental but not edible species is the bird-cherry (which see). The American wild cherry (*Ceräsus virginiana*) is a fine large tree, the timber of which is much used by cabinet-makers and others, though the fruit is rather astringent.

**Cherry-laurel**, the common name of *Ceräsus Lauro-ceräsus*, nat. order Rosaceæ, an evergreen shrub, a native of Asia Minor, but now naturalized in U. States and common in their shrubberies. It is commonly called laurel, but must not be confounded with the sweet-bay or other true species of laurel. The leaves yield an oil nearly identical with that got from bitter almonds. The distilled water (called 'laurel water') from the leaves is used in medicine in the same way as diluted hydrocyanic or prussic acid. It is poisonous in large doses. The Portuguese laurel is another species.

**Cherso** (ker'so), an island in the Adriatic belonging to Austria, yielding wine, olives and other fruits, and having a pop. of 9550. It contains a town of same name; pop. 4670.

**Cherson** (her'son). See *Kherson*.

**Chersonesus** (ker-so-nē'sus; Greek, 'a peninsula'), anciently a name applied to several peninsulas, as the Cimbrian Chersonesus (*Chersonesus Cimbrica*), now Jutland, &c., the Tauric Chersonesus (*Ch. Taurica*), the peninsula formed by the Black Sea and the Sea of Azoff—the Crimea.

**Chert** (chert), a variety of quartz, called also *Hornstone* or *Rock-flint*. It is less hard than common quartz, and is usually amorphous, sometimes globular or in nodules. Siliceous concretions occurring as nodules and layers in limestone rocks are also called chert.

**Chert'sey**, a town, England, in Surrey, 20 miles s.w. of London, on the Thames, giving name to a parl. div. of the county. Bricks and tiles are made, and vegetables largely cultivated. Pop. 3544.

**Cherub** (cher'ub; in the plural *Cherubs* and *Cherubim*), one of an order of angels variously represented at different times, but generally as winged spirits with a human countenance, and distinguished by their knowledge from the seraphs, whose distinctive quality is love. The first mention of cherubs is in Gen. iii. 24. The cherubs in

Ezekiel's vision had each four heads or faces, the hands of a man, and wings. The four faces were the face of a bull, that of a man, that of a lion, and that of an eagle. (Ezek. iv. and x.) In the celestial hierarchy cherubs are represented as spirits next in order to seraphs.

**Cherubini** (ke-ry-bē'nē), MARIA LUIGI CARLO ZENOBIO SALVATORE, an eminent Italian composer, born at Florence in 1760. His first opera, *Quinto Fabio*, was produced in Alessandria in 1780, and in Rome (in an altered form) in 1783, with such success as to spread his fame over Italy. After visiting London he finally settled in Paris, where he became director of the *École Royale* in 1822, and died in 1842. Among his compositions are *Iphigenia in Aulide*, *Lodoiska*, *Faniska*, *Les Deux Journées*, &c. In his later years he confined himself almost exclusively to the composition of sacred music, and gained a lasting fame by his *Coronation Mass*, and more especially his gorgeous *Requiem*.

**Cherusci** (ke-rus'sī), an ancient German tribe, whose territory probably was situated in that part of Germany lying between the Weser and the Elbe, and having the Harz Mountains on the n. and the Sudetic range on the s. This tribe was known to the Romans before 50 B.C., and occasionally served in the Roman armies. But when Varus attempted to subject them to the Roman laws they formed a confederation with many smaller tribes, and having decoyed him into the forests, destroyed his whole army in a battle which lasted three days, and in which he himself was slain (A.D. 9). Upon this the Cherusci became the chief object of the attacks of the Romans. Germanicus marched against them, but though successful in several campaigns did not obtain any permanent advantages. Subsequently the Cherusci were overcome by the Chatti, and latterly they were incorporated among the Franks.

**Cher'vil**, the popular name of umbelliferous plants of the genus *Charophyllum*, but especially of *C. temūlum*, the only British species, a hairy weed with longish grooved fruits. Garden chervil is *Anthriscus cerefolium*, an umbelliferous plant much used in soups and salads in some European countries. The parsnip chervil (*A. bulbōsus*) has a root like a small carrot, with a flavour between that of a chestnut and a potato. Sweet chervil, sweet cicely, or myrrh is *Myrrhis odorāta*, an aromatic and stimu-

## CHESAPEAKE BAY — CHESS.

lant umbellifer formerly used as a pot-herb, growing in a semi-wild state in Britain.

**Ches'apeake Bay**, a spacious bay of North America, in the states of Virginia and Maryland. Its entrance is between Cape Charles and Cape Henry, 16 miles wide, and it extends 180 miles to the northward. It is from 10 to 30 miles broad, and at most places as much as 9 fathoms deep, affording many commodious harbours and a safe and easy navigation. It receives the Susquehanna, Potomac, and James River.

**Che'selden**, WILLIAM, English surgeon and anatomist, born in Leicestershire in 1688, went to London to prosecute his studies, and at the age of twenty-two began to give lectures on anatomy. In 1713 he published a treatise on the Anatomy of the Human Body, long esteemed a favourite manual of the science. In 1723 he published a Treatise on the High Operation for the Stone, and afterwards added to his reputation by operating for the stone. In 1733 was published his Osteography, or Anatomy of the Bones, folio, consisting of plates and short explanations, a splendid and accurate work. He died at Bath April 10, 1752.

**Cheshire** (chesh'ir), or CHESTER, a maritime county and county palatine of England, bounded by the counties of Lancaster, York, Derby, Stafford, Salop, Denbigh, Flint, the estuaries of the Dee and Mersey, and the Irish Sea. The area is 657,123 acres, of which only a sixteenth is uncultivated. The surface is generally level, the soil mostly a rich reddish loam variously clayey or sandy. There is some of the finest pasture land in England; and cheese, the main produce of the Cheshire farmer, is made in great quantities. Extensive tracts of land are cultivated as market-gardens, the produce being sent to Liverpool, Manchester, and other towns. Minerals abound, especially rock-salt and coal, which are extensively worked. Cotton manufacture is carried on at Stockport, Stalybridge, and the north-eastern district, ship-building at Birkenhead and other places. Trade is facilitated by numerous railway lines and a splendid system of canals. The chief rivers are the Mersey, the Dee, and the Weaver. Small sheets of water called *meres* are numerous. Cheshire has eight parliamentary divisions, each returning one member. Principal towns, Chester, the county town, Macclesfield, Stockport, Birkenhead, and Stalybridge. Pop. 1891, 730,052.

**Chesnut.** See *Chestnut*.

**Chess**, a well-known game of great antiquity and of eastern origin, having probably arisen in India, and thence spread through Persia and Arabia to Europe. The name itself as well as many of the terms used in the game are clearly of eastern origin, the word *chess* being formed from the old French *eschecs*, from Persian *shâh*, a king; *rook* is from the Sanskrit *roka*, meaning a ship or chariot; *checkmate* from Persian *shâh mât*, the king is dead. The game is played by two persons on a board which

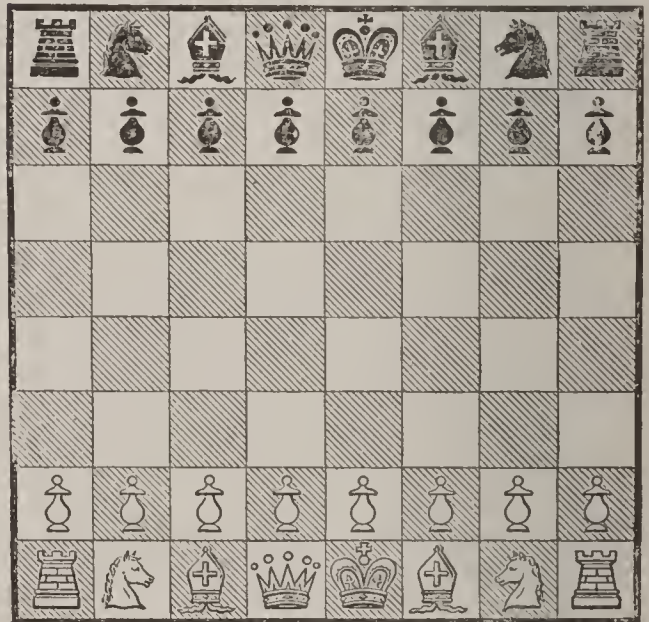

Chess-board.

consists of sixty-four squares arranged in eight rows of eight squares each, alternately black and white. Each player has sixteen men, eight of which, known as *pawns*, are of the lowest grade; the other eight, called *pieces*, are of various grades. They are, on each side, *king* and *queen*; two *bishops*, two *knights*, and two *rooks* or *castles*. The board must be placed so that each player shall have a white square to his right hand. The men are then set upon the two rows of squares next the players; the pieces on the first, the pawns on the second row, leaving between each side four unoccupied rows. The king and queen occupy the central squares facing the corresponding pieces on the opposite side. The queen always occupies her own colour, white queen on white square, black on black. The two bishops occupy the squares next the king and queen; the two knights the squares next the bishops; the rooks the last or corner squares. The pawns fill indiscriminately the squares of the second or front row. The men standing on the king's or queen's side of the board

## CHESS.

are named respectively king's and queen's men. Thus king's bishop or knight is the bishop or knight on the side of the king. The pawns are named from the pieces in front of which they stand; king's pawn, king's knight's pawn, queen's rook's pawn, &c. The names of the men are contracted as follows:—King, K.; King's Bishop, K.B.; King's Knight, K.Kt.; King's Rook, K.R.; Queen, Q.; Queen's Bishop, Q.B.; Queen's Knight, Q. Kt.; Queen's Rook, Q.R. The pawns are contracted: K.P., Q.P., K.B.P., Q.Kt.P., &c. The board is divided, inversely from the position of each player, into eight rows and eight files. Counting from White's right hand to his left, or from Black's left to his right, each file is named from the piece which occupies its first square, and counting inversely from the position of each player to that of the other, the rows are numbered from 1 to 8. At White's right-hand corner we have thus K.R. square; immediately above this K.R. 2; and so on to K.R. 8, which completes the file; the second file begins with K.Kt. square on the first row, and ends with K.Kt. 8 on the eighth. White's K.R. 8 and K.Kt. 8 are thus black's K.R. square and K.Kt. square, and the moves of each player are described throughout from his own position, in inverse order to the moves of his opponent.

In chess all the men capture by occupying the position of the captured man, which is removed from the board. The ordinary move of the *Pawn* is straight forward in the same file; a pawn never moves backward. The first time a P. is moved it may be played forward one square or two; afterwards only one square at a time. But in capturing an adverse piece the P. moves diagonally to occupy the position of the captured man. Thus if White open a game by playing P. to K. 4 and Black answers P. to K. 4, the pawns are immovable; but if White now plays P. to K.B. 4 or P. to Q. 4, Black may capture the P. last advanced. Pawns have another mode of capture peculiar to themselves, and only available against pawns. If Black's P., instead of occupying K. 4, stood on K. 5, and White played P. to Q. 4, Black could not capture it by placing his P. on the square it occupies, which would be a false move; but he is at liberty to make the capture by placing his own P. on the square passed over by White's (Q. 6). This is called taking *en passant*. When a P., by moving or capturing, reaches the eighth square of any file it can no longer remain

a P., but must at once be exchanged for a piece. The player may choose any piece except the king, but the queen, the most valuable piece, is generally the piece chosen. This is called *queening* a pawn, and a player may thus have several queens on the board. *The Rook*.—The moves of the pieces are not, like those of the pawns, limited to a single direction. The R. moves in any direction and for any distance that is open along either the particular row or the file on which it happens to stand. It can, of course, capture any obstructing man and occupy its place. *The Bishop*.—The B.s, like the R.s, are unlimited in range, and move either backward or forward, but their direction is diagonal, and they can never change the colour of their square. *The Queen*.—The Q. combines the moves of the R. and B. She is the most powerful piece on the board, and can move to, or capture at, any distance or direction in a straight line.—*The King*. The K. is at once the weakest and the most valuable piece on the board. In point of direction he is as free as the queen, but for distance he is limited to the adjacent squares. Standing on any central square he commands the eight squares around him and no more. Besides his ordinary move the K. has another by special privilege, in which the R. participates. Once in the game, if the squares between K. and R. are clear, if neither K. nor R. has moved, if K. is not attacked by any hostile man, and if no hostile man commands the square over which K. has to pass, K. may move two squares towards either K.R. or Q.R., and R. in the same move must occupy the square over which K. has passed. This is called *castling*. *The Knight*.—The Kt., unlike the other pieces, never moves in a straight line. His move is limited to two squares at a time, one forwards or backwards, and one diagonally, and he can leap over any man occupying a square intermediate to that to which he intends to go. The Kt., like the K., when on a central square commands eight squares, but they are at two squares' distance, and all in an oblique direction. All captures in chess are optional.

The definite aim in chess is the reduction to surrender of the opposing king. The K. in chess is supposed to be inviolable, that is, he cannot be taken, he can only be in such a position that if it were any other piece it would be taken. Notice of every direct attack upon him must be given by the adversary saying *check*, and when the

K. is attacked all other plans must be abandoned, and all other men sacrificed, if necessary, to remove him from danger, cover the attack, or capture the assailant. It is also a fundamental rule of the game that the K. cannot be moved into check. When the K. can no longer be defended on being checked by the adversary, either by moving him out of danger, or by interposing, or by capture, the game is lost, and the adversary announces this by saying *checkmate*. When, by inadvertence or want of skill, the player having the superior force blocks up his opponent's K so that he cannot move without going into check, and no other man can be moved without exposing him, the player, reduced to this extremity, cannot, without violating the fundamental rule referred to, play at all. In such a case, the one player being unable to play and the other out of turn, the game is considered *drawn*, that is, concluded without advantage to either player. The laws of the game must be sought in some special manual. Many important tournaments and matches have occurred in 1892-96.

**Chest**, in man and the higher vertebrates, the cavity formed by the breast-bone in front and the ribs and backbone at the sides and behind, shut off from the abdomen below by the diaphragm or midriff. It contains the heart, lungs, &c., and the gullet passes through it. See *Thorax*.

**Chester**, an English parliamentary and municipal borough, county town of Cheshire, situated on the Dee about 16 miles from Liverpool. It is a bishop's see, and contains an old and interesting cathedral recently restored. The four principal streets have the roadways sunk considerably below the level of the footways, which run within piazzas covered by the upper portion of the houses, and in front of the ranges of shops. Flights of steps at convenient distances connect the carriage-ways with the footways or 'rows.' There are also shops and warehouses below the rows. These features, together with the ancient walls (now a public promenade) and the quaintly-carved wooden gables of many of the houses, give an antique and picturesque appearance to Chester. Chester has manufactories of lead-pipes, boots and shoes, iron-foundries, chemical works, &c. The port has been improved of late years, but the shifting navigation of the Dee will never allow it to become of leading consequence. Chester returns one member to parliament. Pop. 42,295

**Chester**, a city of Pennsylvania, U.S., on the Delaware, 13 miles w.s.w. of Philadelphia, founded by the Swedes in 1643. Pop. 1890, 20,226.

**Ches'terfield**, a town, England, Derbyshire, 24 miles N. Derby, irregularly but substantially built. The principal manufactures are gingham, lace, and earthenware, but a majority of the working-classes are employed in connection with the collieries, iron-mines, and blast-furnaces of the vicinity. It gives name to a parl. div. of the county. Pop. 1891, 13,242.

**Chesterfield**, PHILIP DORMER STANHOPE, EARL OF, an English statesman and author, was born in London in 1694, and studied at Cambridge. On the accession of George I. (1714) he became gentleman of the bed-chamber to the Prince of Wales, and was returned by the borough of St. Germans, in Cornwall, to parliament. He succeeded his father in the title in 1726, sat in the House of Lords, and acquired some distinction as a speaker. In 1728 he was ambassador to Holland, in 1744 Lord-lieutenant of Ireland, a position which he occupied with great credit, and in 1746 secretary of state; but in 1748 retired from public affairs. He obtained some reputation as an author by essays and a series of letters to his son. His letters to his godson with a memoir by the Earl of Carnarvon were published in 1889. These writings combine wit and good sense with great knowledge of society. Lord Chesterfield died in 1773.

**Chester-le-Street**, a town of England, in the county, and 5 miles N. of Durham, giving name to a parl. div. of the county. It has coal-mines and iron-works. Pop. 6646.

**Chest-foundering**, a disease in horses, a rheumatic affection of the muscles of the chest and fore-legs, impeding both respiration and the motion of the limbs.

**Chestnut**, or CHESNUT, a genus of plants, order Cupuliferæ, allied to the beech. The common or Spanish chestnut (*Castanea vesca*) is a stately tree, with large, handsome, serrated, dark-green leaves. The fruit consists of two or more seeds enveloped in a prickly husk. Probably a native of Asia Minor, it has long been naturalized in Europe, and was perhaps introduced into Britain by the Romans. The tree grows freely in Britain, and may reach the age of many centuries. Its fruit ripens only in some cases, however, and the chestnuts eaten in Britain are mostly imported. Chestnuts form a staple article

of food amongst the peasants of Spain and Italy. The timber of the tree was formerly more in use than it is now; it is inferior to that of the oak, though very similar to it in appearance, especially when old. Two American species of chestnuts, *C. americana* and *C. pumila* (the latter a shrub), have edible fruits. The former is often regarded as identical with the European tree.—The name of Cape Chestnut is given to a beautiful tree of the rue family, a native of Cape



Chestnut (*Castanea vesca*).

Colony.—The Moreton Bay Chestnut is a leguminous tree of Australia, *Castanospermum australe*, with fruits resembling those of the chestnut.—The water-chestnut is the water-caltrop, *Trapa natans*. See *Caltrop*.—The horse-chestnut (which see) is quite a different tree from the common chestnut.

**Chetah** (chē'ta), the *Felis jubata* (or *Cynailūrus jubatus*), or hunting leopard of India, a native of Arabia and Asia Minor. It has its specific name (*jubata*, crested or maned) from a short mane-like crest at the back of the head. When used for hunting it is hooded and placed in a car. When a herd of deer is seen, its keeper places its head in the proper direction and removes its hood. It slips from the car, and, approaching its prey in a stealthy manner, springs on it with several bounds. It is about the size of a large greyhound, has a cat-like head, but a body more like a dog's. A slightly different species inhabits Africa.

**Chettik** (chet'tik), a tree of Java, the *Strychnos Tieute*, yielding a very virulent poison called by the same name, more powerful than that obtained from the upas-tree, and owing its virulence to the strychnine it contains.

**Chet'vert**, a Russian grain-measure, equal

to 0·7218 of an imperial quarter, or 5·77 bushels.

**Cheval**, À (à shè-val; French), on horse-back, astride any object. Troops are said to be arranged *à cheval* when they are placed so as to command two roads, two banks of a river, &c.

**Cheval-glass** (shè-val'), a swing looking-glass mounted on a frame, and large enough to reflect the whole figure.

**Chevalier** (shè-vā-lyā), MICHEL, a celebrated economist, born at Limoges in France, Jan. 13, 1806. He was educated as an engineer in the School of Mines, joined the St. Simonians, and suffered six months' imprisonment for promulgating the free doctrines of Père Enfantin's party. On his liberation M. Chevalier renounced his extreme doctrines, and was sent to the United States and to England on special missions. He became a councillor of state (1838), professor of political economy in the Collège de France (1840), member of the chamber of deputies (1846), and member of the Institute (1851). By this time he had written a number of works: *Lettres sur l'Amérique du Nord*; *Des Intérêts Matériels en France*; *Essais de Politique Industrielle*; *Cours d'Economie Politique*, &c. He was known as a strong advocate of free-trade, and as a specialist on questions of currency. Along with Cobden and Bright he had a great part in the commercial treaty of 1860 between France and Britain. He died in 1879.

**Chevaux-de-frise** (shè-vō' dè frēz; 'Friesland horses,' so called because first used at the siege of Groningen, in that province, in 1658), contrivances used in warfare, consisting of long pieces of timber or iron forming a centre, with long sharp-pointed spikes projecting all round, placed on the ground and serving to defend a passage, stop a breach, &c.

**Che'viot Hills**, a range on the borders of England and Scotland, stretching s.w. to n.e. for above 35 miles; culminating point, the Cheviot, 2688 ft. They are clothed for the most part with a close green sward, and are pastured by a celebrated breed of sheep.

**Cheviot Sheep**, a variety of sheep, taking their name from the well-known Border mountain range, noted for their large carcass and valuable wool, which qualities, combined with a hardiness second only to that of the black-faced breed, constitute them the most valuable race of mountain sheep in the kingdom. The fleece weighs from 3 to 4 lbs., and the carcass of ewes

varies from 12 to 16 lbs. per quarter, that of wethers from 16 to 20 lbs.

**Chevreur** (shè-vreul), MICHEL EUGÈNE, a French chemist, born in 1786. In 1813 he became professor of physical science in the Charlemagne Lyceum, in 1824 director of dyeing in the Gobelins manufactory, in 1830 professor of chemistry in the Collège de France. In 1879 he retired. He has written various works on chemistry and dyeing, and an important work on the Principles of Harmony and Contrast of Colours, translated into English. He died in 1889.

**Chev'ron**, a heraldic and ornamental form, variously used. In heraldry, the chev'ron is an ordinary supposed to represent two rafters meeting at top. It is one of charges called honourable ordinaries, and is usually placed as shown in the accompanying cut. A similar form is used for the distinguishing badge worn on the arm of a non-commissioned officer in the British army. In architecture, the *cherron*

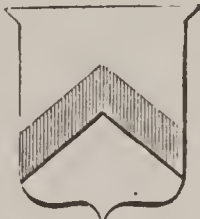

Chev'ron.

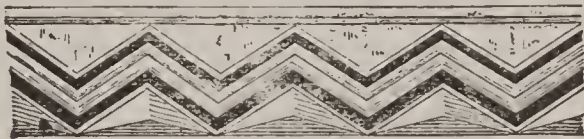

Chev'ron Moulding.

*moulding* consists of a variety of fret ornament of a zigzag form, common in Norman architecture.

**Chev'rotain** (*Tragulus pygmaeus*), a species of small musk-deer found in India and South-eastern Asia and the islands.

**Che'vy Chase**, the name of a celebrated British Border ballad, which is probably founded on some actual encounter which took place between its heroes, Percy and Douglas, although the incidents mentioned in it are not historical. On account of the similarity of the incidents in this ballad to those of *The Battle of Otterbourne*, the two ballads have often been confounded; but the probability is that if any historical event is celebrated at all in the ballad of *Chevy Chase*, it is different from that celebrated in *The Battle of Otterbourne*, and that the similarity between the two ballads is to be explained by supposing that many of the events of the former were borrowed from the latter. There are two versions of the ballad bearing the name of *Chevy Chase*, an older one, originally called *The Hunting*

of the Cheviot, and a more modern one. From the fact that the older version is mentioned in the *Complaynt of Scotland*, written in 1548, it is clear that it was known in Scotland before that time. The age of the more modern version is believed to be no later than the reign of Charles II. This is the version which forms the subject of the critique by Addison in Nos. 70 and 74 of the *Spectator*.

**Cheyenne** (shī-yen'), a town of the U. States, capital of State of Wyoming, on the Union Pacific Railway, where it is joined by the Denver Pacific; a rising place. Pop. 11,693.—The river Cheyenne, or Big Cheyenne, a tributary of the Missouri, is formed by two branches, the N. Fork and the S. Fork, which rise in this state, and have the Black Hills between them, each about 300 m. long, the Big Cheyenne being 150 more.

**Chiabrera** (ki-à-brā'rà), GABRIEL LO, Italian poet, born in 1552, died in 1637; wrote various kinds of poems, and imitated Pindar and Anacreon in odes and canzonets, not unsuccessfully.

**Chiana** (ki-ä'nà; anciently *Clanis*), a river and valley, Italy, in Tuscany and Umbria. The river is artificially divided into two branches, the one flowing into the Arno, the other into the Paglia. By works begun in 1551 and completed only in 1823 the valley of the Chiana has been drained and brought under cultivation, being now one of the most productive portions of Italy.

**Chianti** (ki-än'tē), a district in Italy, near Siena, where what is now the best-known red wine of Italy is produced. Chianti wine is full flavoured and astringent, with an alcoholic strength of about 20 per cent.

**Chian Turpentine** (ki-an), a turpentine or resin obtained from the island of Chios (Scio), yielded by *Pistachia Terebinthus*, a native of the Mediterranean islands and shores, used in medicine. Called also Cyprus turpentine.

**Chiapas** (chi-ä'päs), a state of the Mexican Confederation, area 16,048 square miles. It is in many parts mountainous, is intersected by several considerable streams, and covered with immense forests. The valleys are fertile, and produce much maize, sugar, cacao, and cotton, &c. But trade is quite undeveloped on account of the lack of roads. The capital is San Cristobal. Pop. 209,362.

**Chiaramonte** (ki-ä-rà-mon'tā), a town of Sicily, prov. Syracuse, on a hill in a highly-fertile neighbourhood. Pop. 9364.



**Chiari** (ki-ä'rē), a town of N. Italy, province and 14 miles w. Brescia, with manufactures of silk. Pop. 5999.

**Chiaroscuro** (ki-ä-rō-skō'rō; an Italian term, meaning 'clear-obscure;' in French, *clair-obscur*), in painting, the distribution of the lights and shadows in a picture. A composition, however perfect in other respects, becomes a picture only by means of the chiaroscuro, which gives faithfulness to the representation, and therefore is of the highest importance for the painter. The drawing of a piece may be perfectly correct, the colouring may be brilliant and true, and yet the whole picture remain cold and hard. By the chiaroscuro objects are made to advance or recede from the eye, produce a mutual effect, and form a united and beautiful whole.

**Chiastolite** (kī-as'tō-līt), a mineral, a silicate of aluminium, having crystals arranged in a peculiar manner. The form of the crystals is a four-sided prism, whose bases are rhombs differing little from squares, but each crystal, when viewed at its extremities or on a transverse section, is obviously composed of two very different substances, and its general aspect is that of a black prism passing longitudinally through the axis of another prism which is whitish.

**Chiavari** (ki-ä'vā-rē), a seaport town, Italy, in the province of Genoa, 23 miles E. by S. of Genoa, in a district productive of wine, olives, and silk. Pop. 7659.

**Chiavenna** (ki-ä-ven'nā), a town, Italy, Lombardy, 38 miles N.N.W. Bergamo, in the province of Sondrio, in a valley in the midst of magnificent scenery on the road to the Splügen Pass, with an important transit trade. Pop. 2848.

**Chibouque** (shi-bök'), a Turkish pipe with a long stem.

**Chica** (chē'kā), a red colouring matter which the Indians on the upper parts of the Orinoco and the Rio Negro prepare from the leaves of a plant native to that region called *Bignonia Chica*, and with which they paint their skin, in order to be better able to resist the rays of the sun. See *Bignonia*.

**Chica** (chē'kā), a kind of beer made from maize, in general use in Chile, Peru, and elsewhere in the mountainous regions of South America. The usual method of preparing it is to steep the maize till it begins to grow, when it is exposed to dry in the sun. The malt thus prepared is then ground, mixed with warm water, and left to ferment. The beer, when ready, has a dark-yellow colour,

and a pleasant and somewhat bitter and sour taste, and is very intoxicating. Sometimes the Indians instead of grinding the malt chew it, and this variety of the liquor is considered the best. It is the national drink of the Indians, and consumed by them in great quantities. *Pito* and *poso* are other names for it.

**Chicacole** or CHIKAKOL, a town of India, in the Ganjam district, Madras Presidency, 567 miles N.E. of Madras, notable for its fine muslin manufactures. Pop. 16,355.

**Chicago** (shi-ka'gō), a city, Illinois, United States, the capital of Cook county, on the south-west shore of Lake Michigan, and on both sides of Chicago River. It stands on a level plain, and is surrounded by a beautiful and fertile country. The Chicago River and its two branches separate the city into three unequal divisions, known as the North, the South, and the West, connected by numerous bridges and two tunnels under the river. The streets are wide and are laid out at right angles, many of them being adorned by rows of fine forest trees. The site of the city was originally unhealthy from its lowness, but a large portion of it has been artificially heightened (even while occupied by buildings) by 8 or 10 feet. The public parks have an area of 2000 acres. Among the chief buildings are the new city-hall and court-house, the custom-house and post-office, and the chamber of commerce. There is a university and a large number of higher-class colleges and seminaries. To supply the town with water two tunnels have been constructed which extend for 2 miles under Lake Michigan, and convey the pure water of that lake into the town, where it is pumped up to a height of 160 ft. and distributed. Another tunnel 4 miles long is being constructed. There are also a number of artesian wells. From its position at the head of the great chain of the American lakes, and at the centre of a net-work of railroads communicating with all parts of the Union, Chicago has always been more a commercial than a manufacturing city. There are extensive docks, basins, and other accommodation for shipping. The industries embrace iron-founding, brewing, distilling, leather, hats, sugar, tobacco, agricultural implements, steam-engines, boots and shoes. In commerce Chicago is only second to New York. It has an enormous trade in pork-packing, and is the greatest market for grain and timber in America. Other articles for which it is a centre of

trade are flour, provisions, wool, hides, soft goods, clothing. Before 1831 Chicago was a mere trading station. Its charter is dated March 4, 1837, its population being then 4170, but since then it has advanced at an altogether extraordinary rate. On 9th Oct. 1871 a great fire occurred which burned down a vast number of houses and rendered about 150,000 persons homeless and destitute. But the energy of its inhabitants and its favourable situation enabled it to recover in a surprisingly short time. In 1880 its population was 503,185; by the end of 1887 it had increased to nearly 800,000. In the Census of 1890 it was 1,099,850. The World's Columbian Exhibition was held in Chicago in 1892-1893. It was for the celebration of the four hundredth anniversary of the discovery of America by Columbus, and consisted of an international exhibition of arts, industries, manufactures, &c.

**Chich'ester**, an episcopal and municipal city, and until 1885 a parliamentary borough of England (now giving name to a parl. div.), near the south-west corner of the county of Sussex, well built, with wide streets. Its old wall, still in good preservation and lined with lofty elms, gives it a very picturesque appearance. Its principal edifice is the cathedral, an ancient Gothic structure with a most graceful spire. Chichester takes its name (Cissa-ceaster) from the South Saxon king Cissa, who rebuilt it. Pop. 7842.

**Chick'adee**, the popular name in America of the black-cap titmouse (*Parus atricapillus*) and other allied species, being given from their note.

**Chickahom'iny**, a river in Virginia, rising about 20 miles N.W. of Richmond, flowing S.E. till it joins the James River. Near this river many important battles during the civil war took place—the battle of Williamsburg, of the Seven Pines, of Gaines's Mill, &c.

**Chickamau'ga**, a small tributary of the Tennessee River, state of Tennessee, U.S., where a battle took place Sept. 19-20, 1863, between the Federal troops under Rosecrans and the Confederates under Bragg and Longstreet, the latter gaining the victory.

**Chick'asaw Indians**, a tribe of American Indians of the Appalachian nation. In 1833 they gave up to the United States the last of their lands south of the Tennessee River, receiving as compensation a money indemnity and new lands on the left bank of the Red River, in the Indian Territory. The Chickasaws number about 8000. They

have made considerable advances towards civilization, have a senate, house of representatives, and more than a million dollars in deposit with the Union government.

**Chicken-breasted**, having that form of breast, resulting from malformation or from carious disease or spinal weakness, in which the vertebral column is curved forwards, giving rise to projection of the sternum or breast-bone.

**Chicken-pox** (*Varicella*), an infectious disease mainly confined to children. It commences with feverishness, and an eruption of pimples, which speedily become blebs filled with clear fluid and as large as split-peas. Within a week these dry up into dark-coloured scabs, which within another week have fallen off. The disease is never fatal, and has no evil results. A little opening medicine and a mild diet is all the treatment required.

**Chick-pea**, the popular name of *Cicer arietinum*, which grows wild along the shores of the Mediterranean and in many parts of the East, producing a short puffy pod with one or generally two small wrinkled seeds. It is an important article in French and Spanish cookery, and the plant is cultivated in Europe, Egypt, Syria, India, Mexico, &c. When roasted it is the common *parched pulse* of the East. The herbage serves as fodder for cattle.

**Chick'weed**, the popular name of *Stellaria media*, order Caryophyllaceæ, one of the most common weeds in cultivated and waste ground everywhere in Britain, flowering throughout the year. It has a procumbent more or less hairy stem, with ovate pointed leaves, and many small white flowers. It is much used for feeding cage-birds, which are very fond both of its leaves and seeds.

**Chicla'na**, a town, Spain, Andalusia, 12 miles S.E. Cadiz, built of snow-white stone, contains a magnificent hospital, and has manufactures of linen, earthenware, &c. The sulphur baths, temperature 60°, are efficacious in cutaneous affections, and are much frequented. Pop. 11,627.

**Chic'opee**, a town of Massachusetts, U.S., on the river Connecticut, at the mouth of the Chicopee, with manufactures of cotton, machinery, paper, &c. Pop. 14,050.

**Chic'ory** (*Cichorium*), a genus of composite plants, including the two important species of *C. Endivia* (endive) and *C. Intybus* (chicory or succory). The former, a native of the East Indies, is known under two sorts—the *curled* and the *Batavian*—both for-

ming well-known salads by the blanching of their leaves. The *C. Intybus* or *chicory* is a common perennial plant, from 2 to 3 feet high, from the lower part of which milky leaves rise. The leaves are sometimes



Chicory (*Cichorium Intybus*).

blanched, to be used as salad, in the same way as *C. Endivia*. But the most important part of the plant is its long, fleshy, and milky root, which when roasted and ground is now extensively used for mixing with coffee. Its presence among coffee may easily be detected by putting a spoonful of the mixture into a glass of clear cold water, when the coffee will float on the surface, and the chicory separate and discolour the water as it subsides.

**Chief**, in heraldry, the upper part of the escutcheon cut off by a horizontal line, and normally occupying a third of the shield.

**Chief-justice**, or LORD CHIEF-JUSTICE, in England, the presiding judge in the Queen's Bench division of the High Court of Justice, and, in the absence of the Lord-chancellor, president of the High Court, and also, *ex officio*, one of the judges of the Court of Appeal. The *Chief-justice of the Common Pleas*, previous to 1881, was the presiding judge in the Common Pleas division of the High Court of Justice, but the office is now merged in that of the Chief-justice of England. The title chief-justice is also generally given in the various British colonies to the heads of the different judicial establishments, as in Canada, Australia, &c. In Canada there is not only a chief-justice at the head of the supreme court of the Dominion, but also chief-justices in the separate provinces. Similarly, in the U.

States, the presiding justice of the Supreme court is called chief-justice, as are also similar officers in the individual states. The chief-justice of the United States administers the oath of office on the inauguration of the president and vice-president, and he presides on the trial of an impeached president.

**Chieri** (ki-ā'rē), an old town of North Italy, 8 miles E.S.E. of Turin, with a very large Gothic church, and manufactures of cotton, silk, &c. Pop. 9494.

**Chieti** (ki-ā'tē), a town, Southern Italy, capital of province of same name, on a hill near the right bank of the Pescara. It is well built, is the see of an archbishop, and has manufactures of woollens, &c. Pop. 12,273.

**Chiff-chaff** (*Sylvia* or *Phylloperuste rufa*), a bird, so called from its cry, one of the warblers, a summer visitant to England from the Continent, 4 or 5 inches long; inhabits woods and thickets, and destroys many insect larvæ.

**Chignon** (shēn-yōŋ), a French word, properly signifying the nape of the neck, now used in English and other languages to denote ladies' back hair when raised and folded up, usually round a pad, in a sort of roll on the back part of the head.

**Chigoe** (chig'ō), or JIGGER, a very curious insect (*Pulex* or *Sarcopsylla penetrans*), closely resembling the common flea, but of more minute size, found in the West Indies and South

America. It burrows beneath the skin of the foot, and soon acquires the size of a pea, its abdomen becoming distended with eggs. If these eggs remain to be hatched beneath

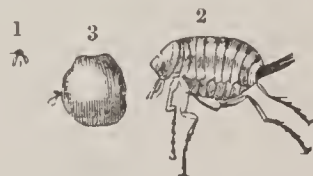

Chigoe (*Pulex penetrans*).

1, Male, nat. size. 2, Male, magnified. 3, Female, full of eggs (nat. size), as taken from a human toe.

the skin great irritation and even troublesome sores are sure to result. The insect must be extracted entire, and with great care, as soon as its presence is indicated by a slight itching or tingling.

**Chih-le** (chi-lé'), or PE-CHI-LE, one of the northern provinces of China, watered by the Pei-ho, containing Peking, the imperial capital. Area about 59,000 sq. miles; pop. 18,000,000.

**Chihuahua** (chē-wā'wā), a city, Mexican Confederation, capital of the state of the same name, generally well built, and sup-

plied with water by a notable aqueduct. It is surrounded by silver mines, and is an important entrepôt of trade. Pop. about 12,000.—The STATE is bounded on the N. by the United States and on the N.E. by the Rio Grandedel Norte; has a healthy climate, and is rich in silver mines. Pop. 225,941.

**Chilaw'**, a seaport town on the west coast of Ceylon, 45 miles N. by W. Colombo, formerly a place of greater importance than it is now.

**Chil'blains** are painful inflammatory swellings, of a deep purple or leaden colour, to which the fingers, toes, heels, and other extreme parts of the body are subject on being exposed to a severe degree of cold. The pain is not constant, but rather pungent and shooting at particular times, and an insupportable itching attends it. In some instances the skin remains entire, but in others it breaks and discharges a thin fluid. Compound camphor liniment is a useful application, and the parts should be kept warm.

**Childbirth.** See *Birth*.

**Childebert**, the name of three kings of the Merovingian dynasty, France. The first of this name was the third son of Clovis, and born about A.D. 495. On his father's death in 511 he succeeded to the kingdom of Paris. Died in 558.—**CHILDEBERT II.** was the son of Sigebert and Brunehaut, and born about 570. He died in 596.—**CHILDEBERT III.**, surnamed *the Just*, son of Thierry I., king of the Franks, was born about 683, and died in 711.

**Childs, GEORGE WILLIAM**, American publisher, was born in Baltimore, Md., May 12, 1829. At the age of twenty-one he was successful as a book publisher, and issued many works of intrinsic merit. Dec. 3, 1864, he became proprietor of the Public Ledger, Philadelphia, which under his care became most profitable. He made liberal use of his wealth for benevolent purposes: and was always regarded a model employer. The Childs-Drexel Home for Union Printers, Colorado Springs, Col., will be a lasting monument of his forethought and care for the workingman. He died Feb. 3, 1894.

**Chili**, or **CHILE** (chē'lē, chē'lā), a country of South America, extending along the Pacific coast from lat. 18° S. nearly to Cape Horn, and including Chiloé and many other islands and part of Tierra del Fuego. It is bounded on the N. by Peru (the river Sama being the boundary), on the N.E. and E. by

Bolivia and the Argentine Republic, from which it is separated by the chief range of the Cordilleras. Its length from N. to S. is about 2400 miles; its breadth, on an average, 120 miles; area, 293,310 sq. miles, divided into a number of provinces and territories; pop. (1890), 2,665,926. By the war with Peru and Bolivia which terminated in 1882 Chili gained all the sea-board of Bolivia, and annexed also the Peruvian provinces of Tarapacá and Tacna (the latter for ten years, after which a plebiscite is to decide whether it shall go to Chili or Peru). The chief towns are Santiago or St. Jago (the capital) and Valparaiso. The rivers are numerous, but small, and have generally rapid currents; the principal are the Biobio, the Valdivia, Lontue, Maule, Itata, and Chuapa or Illapel. The surface is greatly diversified, but rises in elevation as it recedes from the coast and approaches the Andes, along the watershed of which great part of the boundary runs. Some of the summits here rise to 20,000 feet or more, but the elevation decreases towards the south. Chiloé and numerous other islands fringe the coast in the south. Earthquakes are common, those of 1822, 1835, and 1868 being particularly violent. In the Chilean Andes there are twenty volcanoes at least, three of which (Antuco, Villarica, and Osorno) are still active. The climate is remarkably salubrious. In the northern provinces it rarely rains—in some parts perhaps never; in the central parts rain is sufficiently abundant, while in the extreme south there is even an excess of moisture. Among the minerals of Chili are gold, silver, copper, lead, iron, zinc, antimony, manganese, arsenic, tin, sulphur, alum, salt, and cubic nitre. Silver and copper are the two most important metals. The copper mines are most numerous in the northern districts. The cubic nitre, or Chili saltpetre, is a great source of wealth. Coal is wrought at several places. Though possessing many fertile tracts, a great portion of Chili is incapable of cultivation, being naked and mountainous. The province of Atacama is especially destitute of vegetation. From the 29th degree of latitude southwards green valleys and fertile tracts appear, the character of the vegetation getting always richer, till in the southern provinces we find the sides of the Andes clothed with forests and with herbaceous plants and flowers of the richest and most beautiful hues. In some of the northern districts maize is cultivated; in the southern districts wheat and barley are the chief agricultural

## CHILI.

products. Fruits are abundant—apples, pears, apricots, peaches, figs, grapes, oranges, water-melons, &c. The spread of European plants has been so great in some places as to crowd out native species, and cultivation is rapidly carrying this farther. The wild animals include the guanaco, puma, or American lion, the chinchilla, coypu, deer, &c. Cattle are raised in great numbers, from 4000 to 20,000 being some-

times reared on one farm. The manufactures are of little importance, but include cordage, soap, copper wares, leather, brandy, &c. The commerce is increasing rapidly. By far the greater part of the foreign trade is with Great Britain. Mineral products form five-sixths of the total exports, the principal article being cubic nitre (or Chili saltpetre), of which the value

was \$22,500,000 in 1884 and \$28,490,000 in 1890; next come copper, iodine, wheat, silver, &c. The total annual value of exports and imports has in recent years averaged \$53,000,000 to \$55,000,000. Accounts are in pesos or dollars, the silver peso (= 100 *centavos*) having the value of 77 cts. There are about 1600 miles of railway. A line is in progress to cross the Andes into the Argentine Republic.

Chili is a republic, and is considered the best regulated in South America. It is under a president elected for five years and a council of state. The legislature is composed of a senate elected for six years, and a house of deputies elected for three years. The estimated revenue for 1893 was \$50,050,000, the estimated expenditure \$40,731,000. The total debt, home and foreign, 1891, was \$84,824,800. The army numbers about 7000 men; the chief vessels of the navy are three iron clads and one protected cruiser. The Chilians are mostly

of Spanish or Indian descent. They are generally fond of agricultural pursuits, and possess a considerable amount of energy and enterprise. Schools and colleges have been established, and the extension of the benefits of education has been of late one of the constant aims of the government, elementary education being now gratuitous. The Roman Catholic is the established religion of Chili, but the members of other denomi-

nations are allowed to erect edifices in which to worship. The part of Chili lying s. of the river Biobio (or about lat. 38° s.) is inhabited chiefly by Indians. The Araucanians inhabit the region lying between the rivers Biobio and Valdivia, and long maintained their independence, till in 1882 they became subjects of the Chilian government.

Chili originally belonged to the Incas of Peru, from whom it was wrested by the Spaniards under Pizarro and Almagro in 1535. From this period Chili continued a colony of Spain till 1810, when a revolution commenced, which terminated in 1817 in the independence of Chili. Several internal commotions have since occurred; but the country has been free from these compared with other South American states. A war begun with Spain in 1865 led to the blockade of the coast by the Spanish fleet, and the bombardment of Valparaiso in 1866. In 1879 a war broke out with Bolivia and Peru, in reference to the rights of Chili in the mineral district of Atacama. This war was virtually finished in 1881, and the victorious Chilians gained a large accession of territory from both Bolivia and Peru. In 1891 an insurrection, headed by influential members of Congress, caused by dissatisfaction with Pres. Balmaceda's administration, was successful, and resulted in his overthrow.



Costumes of the Environs of Santiago.

**Chillan** (chil-yán'), a town, Chili, capital of the province Nuble, in an angle between the Chillan and Nuble, connected by rail with Talcahuano and Santiago. Pop. about 20,000.

**Chilled Iron**, iron cast in metal moulds called *chills*, where, on account of the rapid conducting of the heat, the iron cools more quickly on the surface than it would do if cast in sand. Chilled iron is whiter and has a harder surface than iron cast in any other way.

**Chillianwal'la**, a village of India in the Punjab, near the Jhelum, famous for a well-contested battle fought in its vicinity in Jan., 1849.

**Chillicothe**, Mo., has 10 churches, 3 flour mills, machine shops. Pop. 1890, 5717.

**Chillicothe** (-koth'e), a beautiful and flourishing town, Ohio, U.S., on the west bank of the Scioto, with manufacturing and other industries. Pop. 11,288.

**Chil'lies**, the fruits of the Capsicum, used to make cayenne pepper, pickles, and chilli vinegar.

**Chil'lingworth**, WILLIAM, an English divine, born at Oxford in 1602, and educated at Trinity College, where metaphysics and theology were his favourite pursuits. Subtle reasoning on authority and infallibility led him for a time into the Church of Rome, but he afterwards returned to the English Church, and published in 1638 a great work in justification of himself, *The Religion of Protestants a Safe Way to Salvation*. He was made Chancellor of the bishopric of Salisbury, and on the outbreak of the civil war supported the king's cause and was made prisoner at the surrender of Arundel Castle. He died 30th Jan. 1644. Sermons and other works were also published by him, but his *Religion of Protestants*, which formed an epoch in English theology, is what has given him lasting fame.

**Chillon** (shē-yōn), a castle, Switzerland, on the Lake of Geneva, 6½ miles s.e. of Vevay, once an important stronghold of the Counts of Savoy, and the prison-house of Francis Bonnard, prior of St. Victor, Geneva, from 1530 to 1536. It has acquired interest from Byron's poem, *The Prisoner of Chillon*.

**Chilo** (kī'lō). See *Chilon*.

**Chiloé** (chēl-wā'), a province and island of Chili. The province comprehends the island of Chiloé, together with a number of other islands, and a portion of the mainland. The island of Chiloé is for the most part

covered with dense forests, but large tracts of it are still unexplored. The chief town is San Carlos, or Ancud. The exports consist chiefly of timber from the forests of the island and the mainland. The climate is healthy but very wet. Area of the province, 30,981 sq. miles; pop. 71,388.

**Chilognatha**, CHILOPODA. See *Chei-*

**Chilon** (kī'lon), or CHILO, one of the so-called seven wise men of Greece. He flourished about the beginning of the 6th century B.C., and was a native of Sparta, and one of the Ephori, or chief magistrates. A collection of his sayings is extant.

**Chiltern Hills**, a range of flint and chalk hills, England, extending through Oxford, Hertford, and Buckingham shires, loftiest summit 905 feet. These hills were anciently covered with forests, and were infested by numerous bands of robbers. To protect the inhabitants of the neighbouring districts an officer was appointed by the crown, called the Steward of the Chiltern Hundreds, and although the duties and emoluments have long ceased the office still exists, and is made use of to afford members of the House of Commons (who cannot give up their seats directly) an opportunity of resigning their seats when they desire to do so. Being regarded as an appointment of honour and profit under government, the acceptance of it disqualifies a member from retaining his seat.

**Chimæra**, CHIMERA (ki-mē'ra), in class. myth. a fire-breathing monster, the foreparts of whose body were those of a lion, the middle of a goat, and the hinder of a dragon. Thus the name came to be used for an unnatural production of the fancy.

**Chimæra** (ki-mē'ra), a genus of cartilaginous fishes. Almost the only known species is the *Chimæra monstrōsa*, which inhabits

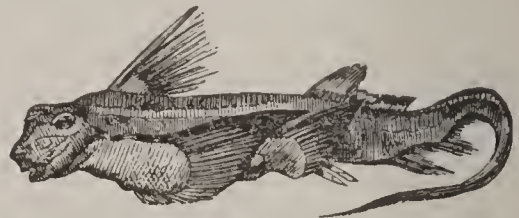

*Chimæra monstrōsa.*

the northern seas, and is sometimes called *king of the herrings*, and, from its two pairs of large teeth, *rabbit-fish*. There is but one gill-opening, and the tail terminates in a point, the fish having on the whole a singular appearance. It seldom exceeds 3 feet in length.

**Chimborá'zo**, a mountain of Ecuador, in the province of Quito, about 90 miles s. by w. Quito; lat. about 2° s. Though not the loftiest summit of the Andes, it rises to the height of 20,703 feet above the level of the sea, and is covered with perpetual snow 2600 feet from the summit and upwards. In 1880 it was ascended to the top for the first time by Mr. E. Whymper.

**Chimere** (shi-mēr'), the upper robe to which the lawn sleeves of a bishop are attached.

**Chimes**, a species of music, mechanically produced by the strokes of hammers against a series of bells, tuned agreeably to a given musical scale. The hammers are lifted by levers acted upon by metallic pins, or wooden pegs, stuck into a large barrel, which is made to revolve by clock-work, and is so connected with the striking part of the clock mechanism that it is set in motion by it at certain intervals of time, usually every hour, or every quarter of an hour. The chime mechanism is sometimes so constructed that it may be played like a piano, but with the fist instead of the fingers.

**Chim'ney**, an erection generally of stone or brick containing a passage by which the smoke of a fire or furnace escapes to the open air. In this sense the first chimneys we hear of are no earlier than the middle ages. The longer a chimney is the more perfect is its draught, provided the fire is great enough to heat the column of air in it, because the tendency of the smoke to draw upwards is in proportion to the difference of weight between the heated air in a chimney and an equal column of external air. Smoky chimneys may be caused either by the presence of other buildings obstructing the wind and giving rise to irregular currents of air, or by improper construction of the fireplace and adjacent parts of the chimney. The first may generally be cured by fixing a chimney-pot of a particular construction, or a revolving cowl, on the chimney top, in order to prevent the wind blowing down; in the second case the narrowing of the chimney throat will generally create a better draught.

**Chimney-piece**, the assemblage of architectural dressings around the open recess constituting the fireplace in a room.

**Chimney-swallow**. See *Swallow*.

**Chimpan'zee**, the native Guinea name of a large West and Central African ape (*Troglodytes niger*) belonging to the anthropoid or man-like monkeys, and to the same genus

as the gorilla. When full grown it is sometimes about 5 feet high, with black hair, and is not so large and powerful as the gorilla. Like the orang it has the hair on its forearm turned backwards, but differs from it in



Chimpanzee (*Troglodytes niger*).

having an additional dorsal vertebra and a thirteenth pair of ribs. It walks erect better than most of the apes. It feeds on fruits, often robs the gardens of the natives, and constructs a sort of nest amongst the branches. It is common in menageries, where it shows much intelligence and docility.

**China**, an immense empire stretching from the centre of Asia, about 75° E. lon., for 3000 miles to the east coast of Corea, in 128° E. lon.; and from the Siberian frontier at the river Amoor, about 50° 30' N. lat., for 2400 miles southwards to the island of Hainan. This vast empire, second in magnitude only to that of Russia and Great Britain, has an area of about 4,500,000 sq. miles, and a population variously estimated at 300,000,000 and 400,000,000, or more, and is usually divided into China Proper and the dependencies: Manchuria, Mongolia, Eastern Turkestan, Dzoungaria, and Tibet, of which Tibet is practically autonomous, although controlled in its foreign relations by the Chinese government. Corea acknowledges the suzerainty of China, but hardly forms part of the empire. The dependencies, though they cover more than 3,000,000 sq. miles, contain but a small and relatively unimportant part of the population (about 30,000,000), China Proper being the centre of power and population.

CHINA PROPER, known to Marco Polo and earlier travellers by the Tartar name of *Cathay*, called 'Middle Kingdom' by

CHINA.

the Chinese, comprises the following provinces:—

	Area in sq. m.	Population.	Capital.
Chihle, . . . .	58,949	17,937,000	Peking.
Shantung, ..	65,104	36,247,835	Tse-nan-foo.
Shansi, . . . .	55,268	12,211,453	Tae-yuen-foo.
Honan, . . . .	65,104	22,115,827	Kae-fung-foo.
Kiangsu, . . .	44,500	20,905,171	Nanking.
Nganhwuy, ..	48,461	20,596,988	Ngan-king-foo.
Kiangsi, . . . .	72,176	5,151,327	Nan-chang-foo.
Chekiang, ..	39,150	11,588,692	Hang-choo-foo.
Fukien, . . . .	53,480	25,769,556	Foo-choo-foo.
Hupei, . . . .	70,450	33,365,005	Wo-chang-foo.
Hunan, . . . .	74,320	21,002,604	Chang-sha-foo.
Shensi, . . . .	67,400	8,432,193	Se-gan-foo.
Kansu, . . . .	86,603	5,411,188	Lan-choo-foo.
Szechuen, ..	166,800	67,712,897	Ching-too-foo.
Kwangtung, .	79,456	29,706,249	Canton.
Kwangsi, . . .	78,250	24,534,118	Que-lin-foo.
Yunnan, . . .	107,969	11,721,576	Yunnan.
Queichow, ..	64,554	7,669,181	Quei-yang-foo.
	1,299,009	382,078,860	

The areas and populations are given differently by different authorities, and the total extent is by some stated to be 1,554,000 sq. miles. Peking is the capital. There are many large and populous cities.

*Physical Features.*—Great part of the country is not well known. The coast-line forms an irregular curve of about 2500 miles. It is not deeply penetrated by gulfs, the only one of great extent being that of Pe-che-le in the north-east, but numerous indentations of sufficient dimensions to form safe and capacious roadsteads are found in every quarter. It is characterized by a fringe of islands and islets, the largest of which are Formosa and Hainan. The Gulf of Pe-che-le, the Yellow Sea, and the China Sea wash the eastern and south-eastern shores, and are characterized by the destructive storms called *typhoons*. The inland boundaries are formed mainly by Tonquin, Burmah, Tibet, and, on the north, partly by the Great Wall separating China from Mongolia, one of the most remarkable of human structures, being an artificial barrier 1500 miles long. Two thirds of the interior are estimated to be mountainous. The general slope is from west to east, and the mountains are a continuation of those of Tibet and Central Asia. The great Kuen-lun range throws off branches, the Tsing-Ling, Fu-niu-shan and Mu-ling, which, running eastward between the great valleys of the Hoang-Ho and Yang-tse-kiang, traverse almost the whole breadth of China. Further north

the Nan-shan branch of the Kuen-lun range runs under various names (Kuliang, Alashan, Inshan, &c.) along the north-east of China till it reaches the frontier of Manchuria, north of Peking. The third great mountain system of China is in the south-east, where extensive chains such as the Nan-shan, the Ta-yu-ling, and Pu-ling stretch on the south side of the Yang-tse-kiang all the way from the highlands of Yunnan to the eastern sea-board. Between these mountain systems, and following courses which may be roughly described as parallel, run the two great rivers of China, the Hoang-ho and the Yang-tse-kiang. Here lie the central and richest provinces of China. On both sides of the lower Hoang-ho is an immense delta plain, consisting generally of a deep alluvial soil of unparalleled fertility. As they approach the sea-coast the two rivers are connected by the Grand Canal, 700 miles in length, thus completing a magnificent system of inland navigation. The Hoang-ho has changed its lower course several times, and is subject to tremendous and disastrous floods. Besides these rivers and their numerous tributaries, the most deserving of notice are the Se-kiang in the south, of considerable size, but still more commercial importance, having at or near its embouchure Canton, Hong-Kong, and Macao; and the Pei-ho, which, though much smaller, forms a water-way between Peking and the Gulf of Pe-che-le. There are a number of lakes, mostly of no great size; the largest is Tung-ting, near the centre of China, with a circumference of about 270 miles. A remarkable feature of the surface of Northern China is the deposit of *loess*, a brownish-yellow earth of great fertility, which covers an immense area both of mountain and valley, and enables agriculture to be successfully carried to the height of 7000 or 8000 feet.

*Climate.*—The greater part of China belongs to the temperate zone, but it has what is called an excessive climate. At Peking in summer the heat ranges from 90° to 100° in the shade, while the winter is so cold that the rivers are usually frozen from December to March. At Shanghai, lat. 31° 20', the maximum temperature reaches 100°, and the minimum falls at least to 20° below freezing-point (12° Fahr.). In the south the climate is of a tropical character, the summer heat rising to 120°. Here the south-west and north-east monsoons blow with great regularity, and divide the



year between them. Among the greatest scourges of the country are the dreadful gales known as typhoons, from the Chinese Ta-fung, or 'great-wind.' They never fail to commit great devastation, though happily they always give such timely notice of their approach that preparations can be made. The Hoang-ho and Yang-tse-kiang basins have a pretty equable temperature, due to the soft moist winds of the Pacific.

*Productions.*—China is well supplied with minerals, including gold, silver, copper, iron, and other metals, and there are very extensive coal-fields, though the quantity raised from them is comparatively small. Salt is abundant, and there are inexhaustible beds of kaolin, or porcelain earth. Among animals it is difficult to mention any that are characteristic of the country; many of them are identical with or differ but little from those of Europe. In the south and south-west the tiger, the rhinoceros, and elephant are found; bears are common in many parts; other carnivora are the wild-cat, badger, lynx, marten, &c. Camels and elephants are used in a domestic state, but the chief domesticated animal is the buffalo. The horses are of a poor breed. Among birds the most beautiful are the gold and silver pheasants. Fish swarm in all inland waters as well as on the coast, the natural supply being immensely increased by artificial means. As regards the flora of China, it is tropical in the south (coco and sago palms, banana, pandanus, &c.), sub-tropical farther north, and still farther north prevails a number of plants and trees identical with or closely akin to those of middle Europe. Flowering plants, shrubs, and trees are so exceedingly abundant as to form a feature. The bamboo, from the immense number of uses to which it is put, is one of the most valuable trees. Oaks, the chestnut, hazel, pines, yew, walnut, &c., are among forest trees. Wax and camphor trees abound. Azaleas are exceedingly numerous; other flowering plants are the camellia rose, passion-flower, cactus, lagerstroemia, &c. Fruits are abundant and varied. The soil, especially of the country comprising the two great river basins, is extremely fertile, and agriculture has always been held in high veneration in China. Rice, as the principal food of the people, is the staple crop. The rich alluvial plains which cover a great part of the surface are admirably adapted for its culture, and by careful management yield amazing crops. In the north there is a variety

called dry-soil rice, which is cultivated like any other cereal. Wheat, barley, and millet are the other chief grain crops. Other crops are maize, buckwheat, a great variety of beans, pease, and pulse generally, sugarcane, tobacco, and vegetables in endless variety, including potatoes, turnips, &c., and at the ports the best European and American vegetables. Varieties of the cabbage tribe are extensively cultivated for the oil extracted from the seeds. Three plants of the greatest economical importance to China are the mulberry, cultivated to provide food for silkworms, cotton, and tea, the last for long regarded as exclusively a Chinese product. Another important crop is the opium poppy, which is extensively grown, though the product is inferior to that of India.

*Manufactures.*—In arts and industry the Chinese have made considerable progress. One peculiar feature in their processes is the general absence of machinery, and the preponderance of manual labour. Among the chief industries is the silk manufacture, which produces some varieties of stuffs unsurpassed anywhere. Everybody wears silks; it is the prescribed attire of high officers. The finer kinds of it form the ordinary dresses of the opulent, while the poorest manage to deck themselves in coarser, if not on common, at least on gala days. The embroidery of silk is carried on to an amazing extent. Cotton goods are also largely made, though great quantities of European and American manufactures are also imported. Flax is not grown, but a good substitute for it is found in the fibres of two or three plants, from which the beautiful grass-cloth, similar in appearance to linen, is extensively woven. Woollens are made only to a limited extent. The porcelain of China has been famous from the earliest periods, and the manufacture of the finest forms of it was long known to the Chinese alone, though their productions are now surpassed by those of Europe. In lacquered ware the Chinese continue unsurpassed. In working in metals they have only attained to mediocrity. The metallic products most deserving of notice are gongs, mirrors, statuettes in copper and bronze, and various kinds of carved, chased, and filigree work, both in gold and silver. In a great number of minor articles the workmanship is exquisite—fans, card-cases, seals, combs, chess-men of wood, ivory, mother-of-pearl, tortoise-shell, &c. Paper is made of a great

variety of substances, and the art of making it—like various others—was practised in China long before Europe acquired it.

*Commerce.*—The inland trade of China, aided by its vast system of water communication, is of incalculable magnitude, the rivers and canals literally swarming with junks, barges, and boats of all sizes. Roads, however, are few and bad, and railways have as yet only made a mere commencement. Telegraphs have made more progress, though the lines as yet do not much exceed 3000 miles. A defective postal system is kept up, partly by the government, partly by private enterprise. By the opening of the principal ports (the 'treaty' ports, twenty-two in number) the foreign commerce has been immensely increased. The chief of these ports are: Shanghai (by far the first), Canton, Hankow, Swatow, Tientsin, Ning-po, and Foo-chow. The main articles of export are tea and raw and manufactured silk; the main imports, cotton goods, opium, metals and metal goods. The total exports and imports usually amount to more than \$200,000,000. In the year 1891 the exports amounted to \$136,352,540; the imports \$135,727,140. Among the countries trading with China the principal are Great Britain, India, Russia, and the U. States. In 1891 Great Britain furnished £6,456,593 of the imports and received £4,713,508 of the exports. The chief article of export to Great Britain is tea, the amount of which from China, exclusive of Hong-Kong and Macao, in 1891 was 57,023,986 lbs. of the value of £2,203,092. In return Great Britain sent to China manufactured cotton and woollen goods of the value of £5,265,235. The quantity of opium imported, almost wholly from India, reaches the value of \$25,000,000 or \$30,000,000 annually.—Among the standards of weight used are the *liang* or *tael* =  $1\frac{1}{3}$  oz. avoirdupois; the *catty* =  $1\frac{1}{3}$  lbs.; and the *picul* = 133 $\frac{1}{3}$  lbs. The *chih* of  $14\frac{1}{10}$  inches is the standard measure of length; a measure of distance is the *li* =  $\frac{1}{3}$  of a mile. There are no national gold and silver coins. The usual unit or denomination of money is the *tael*, the value of which varies according to the rate of exchange; in 1875 it was \$1.50, in 1891 \$1.18. Silver bullion, called *sycee*, and gold bullion, usually stamped with the name of the banker and the year and district in which it is cast, are used in larger transactions. Private bankers are found in all large towns. They issue paper-money, which passes current in the particular districts

where they are known. The Mexican dollar, of the value of \$1, is current in Canton and the south of China.

*People.*—The Chinese belong to the Mongolian race, but in them its harsher features, as represented in the genuine Tartars, are considerably softened. They are generally of low stature, have small hands and feet (the last artificially made so small in the females as to become a deformity), a dark complexion, a wide forehead, black hair, eyes and eyebrows obliquely turned upwards at the outer extremities. In bodily strength they are far inferior to Europeans, but superior to most Asiatics, and their great assiduity and patient endurance of fatigue make them valuable as labourers. They are considered to be deficient in courage. In their moral qualities there is much that is amiable. They are strongly attached to their homes, hold age in respect, toil hard for the support of their families, and in the interior, where the worst kind of foreign intercourse has not debased them, exhibit an unsophisticated simplicity of manners which recalls the age of the patriarchs. In the great mass these qualities are counterbalanced, or rather supplanted, by numerous vices—treachery, lying, and various others. The Chinese use great politeness in their intercourse with each other; but there is perhaps a want of frankness and sincerity. They scrupulously avoid all contradiction and offensive expressions in conversation. Gambling is a universal vice. Drunkenness has hitherto been rare amongst them, but the habit of opium-smoking has much extended of late. But, with many vicious characteristics, the Chinese are preserved from degeneration by their universal frugality and thrift. Hard work, done in the most uncomplaining way, has become second nature with them. Filial piety is also a striking feature of their character, and is, in fact, the principle upon which Chinese society is constituted. They have chambers set apart for the worship of their ancestors, where religious ceremonies are regularly performed.

*Language, Religion, &c.*—The Chinese is the most important and most widely spread of the so-called monosyllabic languages of Eastern Asia, in which each word is uttered by a single movement of the organs of speech. There is no alphabet, each word being represented by a single symbol or character. These written characters appear to have been originally hieroglyphics or rude copies of the objects designed to be

## CHINA.

expressed by them; but the hieroglyphic features have almost entirely disappeared, and many of the symbols are formed of what seems to be an arbitrary combination of lines, or are built up of other symbols combined. In writing or printing the characters are arranged in vertical columns, to be read from top to bottom. The art of making paper is said to have been known in the 1st century after Christ, and printing from wooden blocks in the 7th or 8th cen-

tury, hundreds of years before these valuable arts were re-invented in Europe; and the Chinese literature is now very extensive. There are great numbers of treatises on almost all subjects—science, history, geography, belles-lettres, and poetry; literary eminence is the sure avenue to the highest honours and offices of the state, and hence ‘the *literati* are the gentry, the magistrates, the governors, the negotiators, the ministers of China.’ Among the more



Chinese Mandarin, Lady, Boy, Female Attendant, Soldier, and Bird's-nest Seller.

comfortable classes education of the kind which promises to be best rewarded is almost universal, and in every village there are schools for the lower classes; but attendance is not so general as was at one time supposed. The chief religions in China are Confucianism, Taouism, and Buddhism, the last introduced subsequently to the others. The religion of the learned and of the state, if it may be so called, is that founded by Kong-Fu-Tse or Confucius, about 550 B.C. Taouism, founded by Laotsze, is a compound of mystical and superstitious elements. But amongst the great mass of the people a form of Buddhism prevails, or a sort of mixture of the other three religions. In the western parts Mohammedanism has many followers. The most important Christian missions are those of the French Roman Catholics, who have been longest in the country and have numerous stations. Various Protestant bodies also carry on missionary operations in China, but hitherto with indifferent success, the

Protestant converts only numbering from 25,000 to 30,000.

*Government, Administration, &c.*—The government is an absolute despotism. The reigning dynasty is of Manchu Tartar blood. The emperor unites in his person the attributes of supreme magistrate and sovereign pontiff, and as the ‘Son of Heaven’ is in theory accountable only to heaven. Four principal ministers, two of whom are Manchus and two Chinese, form, along with two assistants, the inner council of state. The government business is distributed among seven boards, having cognizance respectively of all civil officers, of revenue, of rites and ceremonies, of military affairs, of crime, of public works, and of naval affairs. Besides these, there is the Board of General Supervision, or censorate, composed of forty or fifty mandarins, who go out into the empire as imperial inspectors, and are privileged to make any remonstrance to the emperor without endangering their lives. The pro-

## CHINA.

vinces, either singly or by twos, are under a governor and sub-governor, and each province has also a chief criminal judge and a treasurer. Particular magistrates preside over particular districts and cities, and instead of being permanent are changed about once in three years. Although very excellent in theory, the public administration is very deficient in integrity and efficiency. There is no check on the authorities, and the lower mandarins devote their attention to raising money to make up for their insufficient salaries or to purchase higher offices. The Chinese military force consists of the Manchurian army, 270,000 strong, and an army composed of Chinese and other races numbering about 800,000. Under English officers their training and discipline have much improved of late, and the newest kinds of rifles and cannons have been imported from Europe. The navy consists of two fleets—one for rivers and another for sea; but though it numbers many vessels, it is not very efficient, and is scarcely able to clear the Chinese coast from the pirates who infest the numerous creeks and islets. It has lately, however, been much strengthened by a number of steel corvettes built in England and Germany. The revenue of the empire is derived from customs, excise, taxes on land and property, and is said to amount to \$250,000,000, of which one-half is paid in kind. The external debt is only about \$25,000,000.

*History.*—The early history of the Chinese is shrouded in fable, but it is certain that civilization had advanced much among them when it was only beginning to dawn on the nations of Europe. The Chow dynasty, which was founded by Woo-wang, and lasted from about 1100 B.C. to 258 B.C., is perhaps the earliest that can be regarded as historic, and even of it not much more is historic than the name. Under Ling-wang, one of the sovereigns of this dynasty, Confucius is said to have been born, some time in the 6th century B.C. During the latter half of the period during which this line of sovereigns held sway there appear to have been a number of rival kings in China, who lived in strife with one another. Chow-siang, who was the founder of the Tsin dynasty, from which China takes its name, gained the superiority over his rivals, and died in 251 B.C. His great-grandson, a national hero of the Chinese, was the first to assume the title of 'Hoang' (emperor), and called himself Che-Hoang-ti. He ruled over

an empire nearly conterminous with modern China proper. In his reign the great wall (see next art.), designed as a protection against marauding Tartars, was begun in 214 B.C. Buddhism was introduced in 65 A.D. Subsequently the empire broke up into three or more states, and a long period of confusion and weak government ensued. In 960 a strong ruler managed to consolidate the empire, but the attacks of the Tartars were now causing much trouble. In the 13th century the Mongols under Jenghis Khan and his son Ogdai conquered China, and in 1259 the celebrated Kublai Khan, a nephew of the latter, ascended the throne and founded the Mongol dynasty. His ninth descendant was driven from the throne, and a native dynasty called Ming again succeeded in 1368 in the person of Hungwu. A long period of peace ensued, but was broken about 1618, when the Manchus gained the ascendancy, and after a war of twenty-seven years founded the existing Tartar dynasty in the person of Tungchi, establishing their capital in the northern city of Peking, which was nearer their native country and resources than the old capital Nanking. The earliest authentic accounts of China published in Europe are those of Marco Polo, who visited the country in the 13th century. The first British intercourse was attempted under Queen Elizabeth in 1596, and a trade was subsequently established by the East India Company, but no direct intercourse between the governments took place till the embassy of Lord Macartney in 1792. A second embassy in 1816, by Lord Amherst, was treated with insolence; and subsequently the treatment of British merchants became such that a collision was inevitable. In 1840 the British, on being refused redress for injuries, partly real and partly alleged, proceeded to hostilities, and after scattering, almost without a struggle, every force which was opposed to them, were preparing to lay siege to Nanking, when the Chinese found it necessary to sue for peace. A treaty was then concluded (1842), by which the five ports of Canton, Amoy, Foo-chow-foo, Ningpo, and Shanghai were opened to British merchants, the island of Hong-Kong ceded to the British in perpetuity, and the payment of 21,000,000 dollars agreed to be made by the Chinese. In 1850 an insurrection, headed by Hung-seu-tseuan or Tien-te, broke out in the provinces adjoining Canton, with the object of expelling the Manchu

dynasty from the throne, as well as of restoring the ancient national religion of Shan-ti, and of making Tien-te the founder of a new dynasty, which he called that of Tai-ping, or Universal Peace. After a long period of civil war the Tai-ping rebellion was at length suppressed in 1865, chiefly by the exertions of General Gordon and other British and American officers at the head of the Chinese army. In October, 1856, the crew of a vessel belonging to Hong-Kong were seized by the Chinese. The men were afterwards brought back, but all reparation or apology was refused. In consequence of this a war with China commenced, in which the French took part with the British. Peking had to be taken (in 1860) before the Chinese government finally gave way, and granted a treaty securing important privileges to the allies. The present emperor, Tsaitien, succeeded in 1875, but only assumed the reins of government in 1887, on reaching the age of sixteen. War was declared between China and Japan on July 31, 1894. Japan, by a series of brilliant victories, both on land and sea, brought the war to an end in April, 1895. Corea was declared independent, Formosa ceded to Japan, and China was forced to pay a very large war indemnity. The following succinct statement of recent progress in China was recently made by a missionary who has laboured in that country since 1863: 'Who among us, ten years ago, would have dared to imagine that to-day China would have (1) a national fleet; (2) the telegraph radiating to the most distant provinces; (3) government colleges for engineering, navigation, military tactics, electricity, and medicine; (4) the Kai-ping mines supplying steamers and the north ports with excellent and cheap coal; (5) envoys to the leading countries, and consuls at Nagasaki, &c.; (6) Corea open; (7) the China Merchants' Steam Navigation fleet of over forty large vessels; (8) the Kai-ping railway, worked for nearly four years so successfully that an edict has been issued for its extension; (9) a national post-office; (10) scientific questions added to the list presented at several of the last triennial provincial examinations.'

**China, Great Wall of**, the largest artificial structure on the face of the earth, a barrier extending for about 1500 miles in the north of China proper, of which it partly forms the boundary. Its western end is in the deserts of Central Asia, its eastern reaches

the sea to the north eastward of Peking. It was erected as a barrier against the inroads of the barbarous tribes, and dates from about 214 B.C. It is carried over height and hollow, and avoids no inequality of the ground, reaching in one place the height of over 5000 ft. above the sea. Earth, gravel, brick, and stone were used in its construction, and in some places it is much more substantial than in others. Its greatest height, including the parapet on its top, is about 50 feet, and it is strengthened by towers at regular distances.

**China Aster**, the common name of *Callistēphus chinensis*, a composite plant, hardy and free flowering. See *Asters*.

**China-clay**. See *Kaolin*.

**China Grass**, *Boehmeria nivēa*, a plant of the nettle family, a native of Southern and Eastern Asia and the Asiatic islands, and now more or less cultivated in many other countries, such as Southern France, Algeria, Natal, Mauritius, Australia, the United States, Mexico, Jamaica, &c. It yields a fibre which possesses most valuable properties, and has long been made in China into a beautiful cloth, and is probably destined to play a much more important part as a textile material. It is very strong, presents unusual resistance to the effects of moisture, and is fine and silky in appearance. With wool, hemp, cotton, and flax it is believed that it may successfully compete, but its full capabilities are hardly as yet known, though it is long since trials have been made with it as a subject of manufacture. Recently considerable quantities have been used in France, and woven both pure and mixed into various beautiful fabrics. In England such articles as ladies' scarves, handkerchiefs, umbrella-covers, &c., are made of it. Hitherto, however, its high price, owing to the difficulty of preparing it in a suitable form for manufacture, has been against its use, but a sufficiently cheap process of preparation is said to have been recently invented. Called also *Rhea*, *Rheea*, *Ramie*, or *Ramee*.

**China Ink**, a black solid, which, when rubbed down with water, forms a very pure black indelible ink. It has been used in China from time immemorial. There are different accounts of the process, but it appears to be made by boiling the juices of certain plants with water to a syrup, adding to this a quantity of gelatine, and then thoroughly incorporating the carbonaceous matter. There is generally added some

perfume—a little musk or camphor. The mass is then made into square columns of different sizes, which are often decorated with figures and Chinese characters. Many attempts have been made to imitate Chinese ink, some of which have been tolerably successful. Good Chinese ink should have a velvety-black appearance, with a gloss which becomes very conspicuous on rubbing. The colour it gives on paper should be pure black and homogeneous, and if water be passed over it it should not run or become streaky. It is indelible by ordinary solvents, but may be removed sometimes mechanically.

**Chinandega** (chē-nān-dā'gā), a town of Central America, Nicaragua, 20 miles north-west of Leon, connected by railway with the port of Corinto, and carrying on a considerable trade. Pop. 8000.

**China Root**, the root or rhizome of *Smilax China*, a climbing shrubby plant closely allied to sarsaparilla, for which it is sometimes used.

**China Rose**, the name given to a number of varieties of garden rose chiefly derived from *Rosa indica* and *R. semperflorens*, both natives of China. Also a name sometimes given to *Hibiscus rosa sinensis*, one of the mallow tribe, common in China and the East Indies, and an ornament in hothouses.

**China Sea**, that part of the North Pacific Ocean bounded N. by Formosa, N.W. by China, W. by Anam and the Malay Peninsula, S.E. by Borneo, and E. by the Philippines. It contains numerous islands, receives several considerable rivers, and forms the important Gulfs of Siam and Tonquin.

**China-ware**, porcelain, the finest and most beautiful of all the kinds of earthenware, so called from China being the country which first supplied it to Europeans. The Chinese are said to have manufactured porcelain previous to the Christian era, but it was not till five or six centuries later that they attained any great perfection in the art. Japan also appears to have been early acquainted with the manufacture. In the beginning of the 16th century the ware was first introduced into Europe, and won immediate popularity by its beauty and novelty. For long it was thought impossible to fabricate anything similar in Europe, but at length John Frederick Böttcher or Böttiger, a native of Saxony who had long devoted himself to alchemy, discovered a means of producing a porcelain equal in whiteness to that of China. This led to the establish-

ment by the government of the far-famed porcelain manufactory at Meissen, near Dresden. The Saxon porcelain soon became celebrated over Europe, and rivalled that of China in the excellence of its quality and the beauty of its decorations. Subsequently porcelain works were established at Vienna, Munich, and elsewhere in Germany. In France also about the middle of the 18th century the celebrated factory at Sèvres was set up and soon acquired a great renown. The first successful attempt in England to manufacture porcelain was made by some Germans, who established a factory at Chelsea, from which, in 1748, it was transferred to Derby. About twenty years afterwards the valuable discovery in Cornwall of an excellent species of clay contributed greatly to improve the quality of English porcelain, which now began to be largely manufactured in Staffordshire under the auspices of the celebrated Josiah Wedgwood. China-ware, when broken, presents a granular surface, with a texture compact, dense, firm, hard, vitreous, and durable. It is semi-transparent, with a covering of white glass, clear, smooth, unaffected by all acids excepting the hydrofluoric, and resisting uninjured sudden changes of temperature. For the process of manufacture see *Pottery*.

**China Wax**, a sort of wax deposited by insects on a deciduous tree with light-green ovate, serrated leaves, cultivated in the province of Si-chuen (Ssu-chuan) in South-western China. The insects, a species of *Coccus*, are bred in galls which are formed on a different tree, an evergreen (a species of *Ligustrum* or privet), and these galls are transported in great quantities to the districts where the wax trees are grown, to the branches of which they are suspended. Having emerged from the galls the insects spread themselves over the branches, which gradually become coated with a white waxy substance, reaching in 90 or 100 days the thickness of a quarter of an inch. The branches are then lopped off and the wax removed. It is white in colour and is chiefly made into candles; it melts at 160° whereas tallow melts at about 95°.

**Chinch**, the popular name of certain fetid American insects, genus *Rhyparochromus*, resembling the bed-bug, very destructive to wheat, maize, &c., in the southern and western states. Also applied to the common bed-bug (*Cimex lectularius*).

**Chincha Islands** (chin'chá), a group of small islands off the coast of Peru, lat. 13°

38' s.; lon. 76° 28' w. They are granitic, arid, and destitute of vegetation; and the coasts bold and difficult of access. Immense deposits of guano used to exist here, but are now exhausted. Guano from these islands began to be imported into Europe on an experimental scale about 1832, and the trade rapidly grew into importance. The Peruvian government retained the monopoly of the export, and made it one of the chief sources of its revenues.

**Chinchil'la**, a genus of S. American herbivorous rodents very closely allied to the rabbit, which they resemble in the general shape of the body, in the limbs being longer behind than before, in the conformation of the rootless molars, and by the nature of the fur, which is more woolly than silky; but differing from the rabbit in the number of



Chinchilla (*Chinchilla lanigera*).

their incisors and molars, in a greater length of tail, and also in having broader and more rounded ears. *C. lanigera*, a species about 15 inches long, is covered with a beautiful pearly-gray fur, which is highly esteemed as stuff for muffs, pelisses, linings, &c. The chinchilla lives gregariously in the mountains of most parts of South America, and makes numerous and very deep burrows. It is of a gentle nature and very sportive.

**Chinese Exclusion Act.** The act of May 5, 1892, contains all laws now in force prohibiting and regulating the coming into the U. States of Chinese persons and persons of Chinese descent, such act to remain in force for ten years from its passage. Any Chinese adjudged to be not lawfully entitled to remain in the U. States shall be removed to China, unless he shall make it appear that he is a subject or citizen of some other country, in which case he shall be removed to such other country. All Chinese labour-

ers within the U. States must apply to the collector of internal revenue of their respective districts, within one year, for a certificate of residence; and any Chinese neglecting to do this shall be adjudged to be here unlawfully, and may be arrested and taken before a U. States judge, who shall order that he be deported from the U. States, unless he shall prove that by sickness or unavoidable cause he has been unable to procure his certificate, and by at least one **creditable witness that he was a resident** of the U. States at the time of the passage of this act; and if upon the hearing it shall appear that he is so entitled to a certificate, it shall be granted upon his paying the cost. Any Chinaman other than a labourer, having a right to remain in the U. States, desiring such certificate, may apply for and receive the same. At extra session of Congress, 1893, the time for registration was extended to May 3, 1894.

**Ching'leput** (ching'gl-put), or **CHENGALPAT**, a coast district, and its capital, Hindustan, presidency Madras. The district, which lies s. of Arcot and Madras—area, about 2842 square miles—has generally a bad soil, broken up frequently by granite rocks. Pop. 981,381. This tract of country was in 1750 and 1763 obtained by the East India Company from the Nabob of Arcot. The town is 15 miles w. from the Bay of Bengal, and 35 miles s.s.w. Madras, and has a pop. of 5617.

**Chin'iot**, a town of Hindustan, in the Punjab, near the Chenab. Pop. 10,731.

**Chink'apin**, the American dwarf chestnut. See *Chestnut*.

**Chin-kiang**, or **TCHANG-KIANG**, a city, China, province of Kiangsu, right bank of the Yang-tse-Kiang, near the junction of the Imperial Canal; one of the treaty ports, advantageously situated for trade, which it carries on to the value of several millions sterling a year. In 1842 it was taken by the British, after a determined resistance on the part of the Manchu garrison. It suffered severely in the Tai-ping rebellion. Pop. 135,000.

**Chinoline** (kin'o-lin; C<sub>9</sub>H<sub>7</sub>N), an oily liquid obtained by distilling quinine with potash and a little water, or by the dry distillation of coal. It is used in medicine as an antiseptic, and is especially effective when applied to the membranes of diphtheria, being also a remedy in intermittent fevers, &c.

**Chinon** (chē-nōn), a town in France, dep. Indre-et-Loire, on the Vienne, 28 miles s.w.

of Tours. Rabelais was born in its vicinity. Pop. 6096.

**Chinook Winds**, warm westerly winds experienced in some parts of the western U. States.

**Chippewa Falls**, Wis. Pop. 1890, 8670.

**Chinsu'rah**, a town in Hindustan, 20 miles north of Calcutta, beautifully situated on the Hugli, closely adjoining the town of Hugli, and now included in its municipality. It is a military station, was formerly a Dutch settlement, and contains many neat houses in the Dutch style. Pop. (with Hugli), 34,761.

**Chintz**, cotton cloth or calico printed with flowers or other devices in various colours and now generally glazed. Originally a manufacture of the East Indies it is now largely manufactured in Europe.

**Chio** (ki'o). See *Scio*.

**Chiococca** (kī-ō-kok'ka), a genus of tropical plants, nat. order Rubiaceæ, consisting of small, often climbing, shrubs, with funnel-shaped, yellowish flowers; fruit a white berry with two seeds. The bark of the root of *C. anguifuga* is a violent emetic and purgative.

**Chioggia** (ki-od'jä), a seaport town of Italy, on one of the lagoon islands of the Adriatic, 15 miles from Venice. It is built partly on piles, and has some handsome edifices. Its harbour is fortified, and it has ship-building yards, fisheries, and a coasting trade. Pop. 20,381.

**Chios** (kī'os). See *Scio*.

**Chip-hat**, a hat made of chips or wood cut into thin filaments and plaited, so as to resemble a straw-hat.

**Chip'munk**, CHIP'MUCK, the popular name in America of the ground-squirrel, genus *Tamias*.

**Chip'penham**, a municipal and till 1885 parliamentary borough of England, Wiltshire, 12 miles N.E. of Bath, on the Avon, with one of the largest marts for cheese in the kingdom. It now gives name to a parl. div. of the county. Pop. 1891, 4618.

**Chippewayans** (chip'pe-wā-anz), a race of Indians in the north-west territories of Canada.

**Chippeways** (chip'e-wāz), or OJIBBEWAYS, a tribe of North American Indians, United States and Canada. They are distributed in bands round both sides of the basin of Lake Superior, where they once owned vast tracts. They are of the Algonquin stock, tall, active, and well formed, subsist chiefly by hunting and fishing, and number about 18,000.

**Chipping-Norton**, a municipal bor. of England, Oxfordshire, 12 m. s.w. of Banbury. Pop. 1891, 4222.

**Chipping Sparrow** (*Spizella sociālis*), a common N. American bird, some five or six inches long.

**Chipping-Wycombe**. See *Wycombe*.

**Chiquimula** (chi-ki-mö'là), a department of the central American State of Guatemala; area 4000 sq. miles. Pop. 53,000.

**Chiquitos** (chi-kē'tōs), an Indian people of Bolivia, about the head-waters of the Madeira and Paraguay. They number about 22,000, distributed amongst ten missions which still survive as a monument of Jesuit perseverance.

**Chiragra** (kī-rag'ra), that species of gout which attacks the joints of the hand (the wrist and knuckles) and hinders their motions. It gradually bends, distorts, and finally stiffens the fingers.

**Chiretta** (ki-ret'ta), or CHIRA'TA, an Indian bitter derived from the dried stems of *Agathōtes Chirāta* (or *Ophelia Chirāta*), a gentianaceous plant from the north of India. It is very similar in its properties to gentian, and is used medicinally for similar purposes.

**Chiriqui** (chi-ri-kē'), a district in the state or department of Panamá, Colombia. It is naturally very fertile, and has good harbours both on the Caribbean and Pacific coasts. The name is also given to a lagoon and an archipelago on the coast of this state.

**Chiromancy** (kī'ro-man-si). See *Cheiro-mancy*.

**Chiron** (kī'ron), the most famous of the Centaurs, a race fabled as half-men half-horses. He lived at the foot of Mt. Pelion in Thessaly, and was celebrated through all Greece for his wisdom and acquirements, particularly for his skill in medicine and music, and the greatest princes and heroes of the time—Bacchus, Jason, Hercules, Achilles, &c.—were represented as his pupils.

**Chironectes**. See *Cheironectes*.

**Chiru** (chē'rō), *Antelope Hodysonii*, a fine large species of antelope found in Tibet, somewhat larger than the chamois.

**Chis'lehurst**, a parish and village of England, in Kent, where (at Camden Place), Napoleon III. lived after the Franco-German war, dying in 1873.

**Chisleu** (kis'lū), the ninth month of the Jewish year, commencing with the new moon in December or the latter part of November. The modern Jews fast on the sixth day of this month.



**Chiswick** (chis'ik), a town and parish, England, county of Middlesex, 5 miles w. of Hyde Park Corner, London. There are many fine villas and gardens in the neighbourhood. Pop. 1891, 21,964.

**Chitaldrúg** (chit-al-drög'), a district and town of India, Mysore native state. The district, which is arid and stony, has an area of 4571 sq. miles; pop. 376,310.—The town has fortifications constructed by Haider Ali, and was a station for British troops. Pop. 4271.

**Chitin** (kí'tin;  $C_9H_7NO_5$ ), the chief tissue-forming ingredient of the wing-cases of insects, and the shells of crabs and other crustaceans. From these sources it can be obtained by successive treatment with different solvents to remove inorganic matter, fat, &c. It is solid, transparent, and horny.

**Chitons** (kí'tonz), CHITONIDÆ, a family of gasteropods, affording the only instance known of a molluscan shell formed of many successive portions, often in contact and overlapping each other, but never truly articulated. The shell in the typical genus *Chiton* is composed of eight pieces, the animal adhering to rocks or stones after the fashion of the limpet. The species are numerous, and there are few rocky shores without some of them.

**Chittagong** (chit'-) a district, Hindustan, in the s.e. of Bengal, having the Bay of Bengal on the w.; area, 2567 sq. miles; pop. 1,132,341. The level lands, chiefly on the coast and the valleys, are very fertile. A considerable majority of the inhabitants are Mohammedans. Chittagong is also the name of a commissionership or division of Bengal. Area, 12,118 square miles; pop. 3,574,048.—The city of Chittagong, chief town of the district and second port in Bengal, is situated on the Karnaphuli about 12 miles from its mouth. Though very unhealthy, its trade has of late been steadily increasing. Pop. 20,969.

**Chittagong Wood**, the wood of several Indian trees, especially of *Chickrassia tabularis*, order Cedrelaceæ, a light-coloured beautifully-grained wood used by cabinet-makers. Also *Cedrēla Toona*. See *Toon*.

**Chitteldroog**. See *Chitaldrúg*.

**Chittoor'**, or CHITTORE, a town of India, capital of the North Arcot District, Madras Presidency. Pop. 5809.

**Chiusa** (ki-ö'sá), two Italian towns, one in N. Italy, prov. Cuneo, pop. 6576; the other in Sicily, prov. Palermo, pop. 7129.

**Chiusi** (ki-ö'sē), the *Clusium* of the Ro-

mans; a town of Italy, province Sienna, and 43 miles s. from Arezzo. It was the capital of Lars Porsenna, and has rich collections of Etruscan and Roman antiquities. Pop. 2226.

**Chivalry** (chiv'al-ri; French *chevalerie*, from *cheval*, a horse), a term which indicates strictly the organization of knighthood as it existed in the middle ages, and in a general sense the spirit and aims which distinguished the knights of those times. The chief characteristics of the chivalric ages were a war-like spirit, a lofty devotion to the female sex, a love of adventure, and an undefinable thirst for glory. The Crusades gave for a time a religious turn to the spirit of chivalry, and various religious orders of knighthood arose, such as the Knights of St. John, the Templars, the Teutonic Knights, &c. The education of a knight in the days of chivalry was as follows: In his twelfth year he was sent to the court of some baron or noble knight, where he spent his time chiefly in attending on the ladies, and acquiring skill in the use of arms, in riding, &c. When advancing age and experience in the use of arms had qualified the page for war, he became an *esquire*, or *squire*. This word is from L. *scutum*, a shield, it being among other offices the squire's business to carry the shield of the knight whom he served. The third and highest rank of chivalry was that of knighthood, which was not conferred before the twenty-first year, except in the case of distinguished birth or great achievements. The individual prepared himself by confessing, fasting, &c.; religious rites were performed; and then, after promising to be faithful, to protect ladies and orphans, never to lie nor utter slander, to live in harmony with his equals, &c., he received the *accolade*, a slight blow on the neck with the flat of the sword from the person who dubbed him a knight. This was often done on the eve of battle, to stimulate the new knight to deeds of valour; or after the combat, to reward signal bravery. Though chivalry had its defects, chief amongst which, perhaps, we may note a tendency to certain affectations and exaggerations of sentiment and profession, yet it is to be regarded as tempering in a very beneficial manner the natural rudeness of feudal society. As a system of education for the nobles it taught them the best ideals, social and moral, which the times could understand, and filled a place in civilization which as yet the arts and letters could hardly occupy.

**Chivasso** (kē-vās'sō), a town of Italy, 14 miles N.E. of Turin. Pop. 4375.

**Chive**, or CIVE (chīv, sīv), a small perennial garden plant (*Allium Schœnopræsum*) of the same genus as the leek and onion, and used for flavouring soups, &c. It is a rare native of Britain, where it is often cultivated as an edging for garden plots.

**Chladni** (hlād'nē), ERNST FLORENT FRIEDRICH, German physicist, born 1756, died 1827. He investigated the laws of sound and made important experiments on the vibration of metallic and glass plates of various forms. His works include Discoveries Concerning the Theory of Sound, 1787; Acoustics, 1802; Contributions to Practical Acoustics, with Remarks on the Making of Instruments, 1822; &c.

**Chladni's Figures**, the figures formed by sand strewn on a horizontal glass or metal plate, or even a slip of wood, when it is clamped firmly at one point, and set in vibration by means of a violin-bow.

**Chlamydosaurus**. See *Friiled Lizard*.

**Chlamyphorus** (kla-mif'o-rus), a genus of quadrupeds of the order Edentāta. The only species, *C. truncātus*, or pichiciago, resembles the mole in its habits; it is about 5 inches long, and its back is covered over with a coat of mail, consisting of twenty-four rows of tough leathery plates. Its internal skeleton in several respects resembles that of birds. It is a native of South America, and nearly allied to the armadillo.

**Chlamys** (klam'is), a light and freely-flowing scarf or plaid worn by the ancient Greeks as an outer garment. It was oblong in shape, generally twice as long as its width.

**Chlo'ral** (C<sub>2</sub>HCl<sub>3</sub>O), a liquid first prepared by Liebig by passing dry chlorine gas through absolute alcohol to saturation, afterwards by Stædeler by the action of hydrochloric acid and manganese on starch. The *hydrate of chloral*, as now prepared (C<sub>2</sub>HCl<sub>3</sub>O.H<sub>2</sub>O), is a white crystalline substance, which, in contact with alkalis, separates into chloroform and formic acid. Chloral kills by paralysing the action of the heart. It is a hypnotic as well as an anæsthetic, and is frequently substituted for morphia. It has been successfully used in delirium tremens, St. Vitus's dance, poisoning by strychnia, in tetanus, and in some cases of asthma and whooping-cough. It should be taken with great caution and under medical advice, as an extra dose may produce serious symptoms and even death. The treatment of poisoning by chloral is to keep the person

warm by means of blankets, warm bottles, &c. Warm stimulating drinks should also be administered, such as hot coffee, hot tea, negus, &c. It has been shown that an animal kept warm by wrapping in cotton wool recovered from a dose of chloral that otherwise would have killed it.

**Chlorantha'ceæ**, a nat. order of apetalous exogens, allied to the peppers, and, like them, having an aromatic fragrant odour; natives of the warm regions of India and America. *Chloranthus officinālis* is reckoned a stimulant and tonic of the highest order.

**Chlo'rate**, a salt of chloric acid. The chlorates are very analogous to the nitrates. They are decomposed by a red heat, nearly all of them being converted into metallic chlorides, with evolution of pure oxygen. They deflagrate with inflammable substances with such facility that an explosion is produced by slight causes. The chlorates of sodium and potassium are used in medicine. The latter, in doses of from five to twenty grains, is largely used in scarlet fever, inflamed throat, &c. It is also used in the manufacture of lucifer-matches, fireworks, and percussion-caps.

**Chloric Ether**, a volatile liquid (C<sub>2</sub>H<sub>5</sub>Cl) obtained by passing hydrochloric acid gas into alcohol to saturation and distilling the products. Called also *Hydrochloric Ether*.

**Chloride of Lime**. See *Bleaching-powder*.

**Chlorim'etry**, the process of testing the bleaching power of any combination of chlorine, but especially of the commercial articles the chlorides of lime, potash, and soda.

**Chlo'rine** (sym. Cl.; at. weight 35.5), an elementary gaseous substance discovered by Scheele in 1774, who named it *dephlogisticated marine acid*. It was afterwards proved by Davy to be a simple body, and from its peculiar yellowish-green colour the appellation of *chlorine* (from Greek *chlōros*, yellowish-green) was given to it. It is always found in nature in a state of combination. United with sodium it occurs very largely as the chloride of sodium or common salt, from which it is liberated by the action of sulphuric acid and manganese dioxide. Chlorine is a very heavy gas, being about two and a half times as heavy as ordinary air; it has a peculiar smell, and irritates the nostrils most violently when inhaled, as also the windpipe and lungs. It exercises a corrosive action upon organic tissues. It is not combustible, though it supports the combustion of many bodies, and, indeed, spontaneously burns several. In combina-

tion with other elements it forms chlorides, which act most important parts in many manufacturing processes. This gas may be liquefied by cold and pressure, when it becomes a transparent, greenish-yellow, limpid liquid. Chlorine is one of the most powerful bleaching agents, this property belonging to it through its strong affinity for hydrogen. Hence in the manufacture of bleaching-powder (chloride of lime) it is used in immense quantities. When applied to moistened coloured fabrics it acts by decomposing the moisture present, the oxygen of which then destroys the colouring matter of the cloth, &c. It is a valuable disinfectant where it can be conveniently applied, as in the form of chloride of lime.

**Chlo'rite**, a mineral of a grass-green colour, opaque, usually friable or easily pulverized, composed of little spangles, scales, prisms, or shining small grains, and consisting of silica, alumina, magnesia, and protoxide of iron. It is closely allied in character to mica and talc. There are four subspecies—chlorite earth, common chlorite, chlorite slate, and foliated chlorite.

**Chlo'rodyne**, a popular patent medicine used in allaying pain and inducing sleep, and containing morphia, chloroform, prussic acid, extract of Indian hemp, &c. There are several makes of it, but all have to be used with caution.

**Chlo'roform** ( $\text{C H Cl}_3$ ), the perchloride of formyle, a volatile colourless liquid of an agreeable, fragrant, sweetish apple taste and smell, of the specific gravity of 1.48, and discovered by Sonbeiran and Liebig in 1832. It is prepared by cautiously distilling together a mixture of alcohol, water, and chloride of lime or bleaching-powder. Its use as an anæsthetic was introduced in 1847 by Prof. (afterwards Sir) James Y. Simpson of Edinburgh. For this purpose its vapour is inhaled. The inhalation of chloroform first produces slight intoxication; then, frequently, slight muscular contractions, unruliness, and dreaming; then loss of voluntary motion and consciousness, the patient appearing as if sound asleep; and at last, if too much be given, death by coma and syncope. When skilfully administered in proper cases it is considered one of the safest of anæsthetics; but it requires to be used under certain precautions, as its application has frequently proved fatal. Chloroform is a powerful solvent, dissolving resins, wax, iodine, &c., as well as strychnine and other alkaloids.

**Chlo'rophane**, a mineral, a variety of fluor-spar which exhibits a bright-green phosphorescent light when heated.

**Chlo'rophyll**, the green colouring matter of plants. It plays an important part in the life of the plant, as it breaks up the carbonic acid gas taken in by the stomata of the leaves into its two elements, carbon and oxygen, returning the oxygen to the air, and converting the carbon with the water obtained from the roots into starch. Light is indispensable to the formation of chlorophyll, and hence arises the etiolation or blanching of plants by privation of light, either by the art of the gardener or from accidental causes.

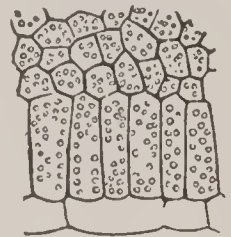

Chlorophyll Granules in Cells of a Leaf.

**Chloro'sis** (Greek, *chlōros*, yellowish-green), or GREEN SICKNESS, a disease specially affecting young girls, is characterized by a greenish or yellowish hue of the skin, languor, indigestion and general debility, and derangement of the system. The pathological condition of chlorosis is a diminution in quantity of the red globules of the blood, an important constituent of which is iron, and accordingly the administration of iron forms a leading part of the treatment of this disease.—The term is also applied to a disease of plants in which a deficiency of chlorophyll causes a blanched and yellow appearance instead of a healthy green in the plant. It is artificially produced in some esculent vegetables to destroy their bitter flavour.

**Chlorosper'meæ**, a name given to one of the divisions of the algæ, having grass-green fronds, very rarely purple, olive, or red. They grow either in the sea, in fresh water, or in damp situations, and are of very simple organization.

**Choate**, RUFUS, lawyer, born in Essex, Mass., 1799; died, 1859. In 1830 he was elected to Congress; also in 1832. In 1841 he succeeded Daniel Webster in the U. S. Senate, serving until 1845. In many respects he was the most scholarly of American public men, and among the greatest forensic advocates America has produced.

**Cho'colate** (from Mexican *chocolatl*), a paste composed of the kernels of the *Theobroma Cacao* or cacao-tree, ground and combined with sugar and vanilla, cinnamon, or other flavouring substance; also a beverage made by dissolving chocolate in boiling water

or milk. It was used in Mexico long before the arrival of the Spaniards, and is now largely used in S. America, Spain, Italy, and Germany, but in Britain cocoa, which is a preparation from the same fruit, is much more common.

**Choc'taws**, a North American Indian tribe now settled on a portion (10,450 sq. m.) of the Indian Territory on the Red River. They formerly inhabited what is now the w. part of Alabama and s. part of Mississippi. They cultivate the soil, are partially civilized, having a regular constitution prefaced with a bill of rights, courts of justice, books and newspapers.

**Choczim** (*ho'tsim*). See *Khotin*.

**Choir** (*quīr*), that part of a cruciform church extending eastward from the nave to the altar, frequently inclosed by a screen, and set apart for the performance of the ordinary service. The name is also given to the organized body of singers in church services.

**Choiseul** (*shwä-seul*), an ancient French family which has furnished many distinguished individuals. One of the best known is Étienne François, duke of Choiseul-Amboise, born 1719, died 1785. He entered the army in early life, and after distinguishing himself on various occasions in the Austrian war of Succession, returned to Paris, where his intimacy with Madame de Pompadour furnished the means of gratifying his ambition. After having been ambassador at Rome, and at Vienna, where he concluded with Maria Theresa the treaty of alliance against Prussia, he became in reality prime-minister of France, and was very popular through a series of able diplomatic measures. He negotiated the famous Family Compact which reunited the various members of the Bourbon family, and restored Corsica to France. His fall was brought about in 1770 by a court intrigue, supported by Madame du Barry, the new favourite of the king. He was banished to his estates, but his advice in political matters was frequently taken by Louis XVI.

**Choisy-le-roi** (*shwä-sē-l-rwä*), a handsome town, France, 7 miles s. of Paris, on the Seine. In its cemetery is the tomb of Rouget de l'Isle, author of the Marseillaise. Pop. 7853.

**Choke-cherry**, a popular name for one or more species of cherry (such as *Prunus* or *Ceräsus boreälis*, *Prunus Virginiana*), distinguished by their astringency.

**Choke-damp**, or AFTER-DAMP, the name

given to the irrespirable gas (carbonic acid) found in coal-mines after an explosion of fire-damp or light carburetted hydrogen.

**Cholagogue** (*kō'la-gōg*), a medicine which has the property of carrying off bile.

**Cholera** (*kol'è-ra*), an acute contagious and very fatal disease. In its more ordinary form it commences with sickness, vomiting, or perhaps two or three loose evacuations of the bowels; after which follow a sense of burning at the præcordia, an increased purging and vomiting of a white or colourless fluid, great prostration of strength, spasms at the extremities, which increase in violence with the vomiting and purging. Such cases may last from twelve to thirty six hours; after this the patient generally sinks into a state of extreme collapse, and this stage in most cases passes by a gradual transition into a febrile one, which in a majority of instances proves fatal. Sometimes the patient is suddenly stricken down and dies, collapsed within a few hours without diarrhœa or vomiting. This disease is endemic in certain parts of Asia (hence it is sometimes called Asiatic cholera), and is liable to spread to other parts of the world, usually by the ordinary channels of commercial intercourse. It first appeared in Europe in 1829, and reached Britain in 1831, spreading thence to America. Western Europe was again visited by it in 1847, 1853, 1865, 1873, 1875, and in 1885. In 1892 Russia and Western Europe suffered severely.

The primary and essential element in the production of cholera has been ascertained to be a constituent of the excreta of cholera patients. Whether this particular substance is the germ of a fungus or other form of minute life is not quite certain, but that it is an organism capable of propagating itself when it is taken into the alimentary canal in food, impure water, or the like, is beyond a doubt. Dr. Koch asserts that the essential cause is a bacillus, having the form of a curved rod, hence called the *comma bacillus*, and that the disease is caused by the multiplication of this organism in the small intestines. The fact that great numbers are present in persons suffering from cholera is generally admitted, but it is doubted by other experts if they do actually produce the disease. A method of protective inoculation against cholera has been lately tried in Spain, but with small success. The contagion of cholera is not so likely to be conveyed by personal intercourse as by residence in an infected district. Sanitary mea-

tures have proved to be the only efficacious means of arresting an epidemic; insanitary conditions decidedly favour it.

What is called *cholera morbus* is a bilious disease, long known in most countries, and is characterized by copious vomiting and purging, with violent griping, cramps of the muscles of the abdomen and lower extremities, and great depression of strength. It is most prevalent at the end of summer or the beginning of autumn. *Cholera infantum* (infants' cholera) is the name sometimes given to a severe and dangerous diarrhœa to which infants are liable in hot climates or in the hot season.

**Cholesterine** (kō-les'ter-in;  $C_{26}H_{41}O$ ), a substance found in bile, blood, &c., which may be obtained in the form of beautiful pearly crystalline scales, without taste and odour. It is widely distributed in the animal economy, being essential to the brain and nerve substance, and having been found in milk, and many portions of the body, both as a normal and a pathological constituent.

**Cholet** (sho-lā), a town of N.W. France, dep. Maine-et-Loire, 32 miles s.w. of Angers, with manufactures of cotton goods and woollen stuffs, and a brisk trade. Pop. 12,852.

**Cholochrome** (kō'lo-krōm), **CHOLOPHÆIN** (kō-lo-fē'in), the brown colouring matter contained in bile and in the intestines, and the substance colouring the fæces and the skin in jaundice.

**Cholos** (chō'lōs), in Peru, the name for those who are partly of white, partly of Indian parentage, the most numerous class of the community.

**Cholula** (chō-lō'lā), a town of Mexico, 60 miles s.e. by E. of Mexico, formerly a large city, the seat of the religion of the ancient Mexicans, with more than 400 temples. One of these temples still remains, built in the form of a pyramid, each side of its base measuring 1440 feet, and its height in all 164 feet. On the top is a chapel of Spanish origin. Pop. 10,000.

**Chondrite** (kon'-), a fossil sea-weed.

**Chondropterygii** (kon-drop-te-rij'i-ī), one of the two great sections into which Cuvier divides the class Pisces or fishes, distinguished from the fishes with true bone by the cartilaginous or gristly substance of which the bones are composed, and by the cartilaginous spines of the fins. The families include the sturgeon, shark, ray, and lamprey.

**Chondrus**, the genus of sea-weeds to which carrageen or Irish moss belongs.

**Chonos Archipelago** (chō'nōs), a group of islands lying off the w. coast of Patagonia, mostly between lats. 44° and 46° s., and lon. 74° and 75° w. Two are large, but they are all barren and scantily inhabited.

**Chop'in**, a Scotch liquid measure containing two imperial pints or one quart.

**Chopin** (sho-pān), **FRÉDÉRIC FRANÇOIS**, pianist and musical composer, of French extraction, was born at Warsaw in 1810, went to Paris in 1831 on account of the political troubles of Poland, and died there in 1849. He wrote numerous pieces for the pianoforte, chiefly in the form of nocturnes, polonaises, waltzes, and mazurkas; all of which display much poetic fancy, abounding in subtle ideas with graceful harmonic effects.

**Chopine** (chop-ēn'), a very high shoe or elevated clog, introduced into England from Venice, in the reign of Queen Elizabeth, and which became the fashionable wear of court ladies during that reign. They were made of wood covered with leather of sundry colours, white, red, yellow, and sometimes gilt. Some of them were of great height, as much as 18 inches, the height of the chopine being seemingly regarded as a mark of the rank of the wearer.



Chopines.

**Chop-sticks**, the Chinese substitute for our knife, fork, and spoon at meals, consisting of two smooth sticks of bamboo, wood, or ivory, which are used for conveying meat to the mouth with wonderful dexterity.

**Choragic Monument** (ko-rā'jik). See *Choragus*.

**Choragus** (ko-rā'-), a name given by the Greeks to the leader or director of the choruses furnished for the public festivals, and who also defrayed the expenses of the chorus. (See *Chorus*.) The choragus who was adjudged to have performed his duty best received a tripod of brass, for which he had to build a monument, on which it was placed. A street in Athens which contained a great number of these choragic monuments was called the Street of the Tripods.

**Chorale** (ko-rā le), or **CHO'RAL**, the psalm or hymn tune of the German Protestant churches, a simple melody to be sung in

harmony or in unison by a number of voices to sacred words.

**Choral Music** (kō'ral), vocal music in parts; music written or arranged for a choir or chorus, and including oratorios, cantatas, masses, anthems, &c.

**Choral Service**, in the Church of England, service with intoned responses, and the use of music throughout wherever it is authorized. The service is said to be *partly* choral when only canticles, hymns, &c., are sung; *wholly* choral, when, in addition to these, the versicles, responses, &c., are sung.

**Chord** (kord; Greek *chordē*, a string of gut), in music, the simultaneous combination of different sounds, consonant or dissonant. The common *chord* consists of a fundamental or bass note with its third and fifth. When the interval between the bass note and its third is two full tones the combination is a *major chord*; when the interval is a tone and a half the combination is termed a *minor chord*; when the intervals between the bass note and its third and the third and the fifth are each a tone and a half, the chord is called *diminished*. The *tonic chord* is made up of the key-note and its third and fifth; the *dominant chord* consists of the dominant or fifth of the scale accompanied by its third and fifth; the *subdominant chord* has for its root or bass the subdominant or fourth of the scale, accompanied with its third and fifth. —In geom. a chord is a straight line drawn, or supposed to extend, from one end of an arc of a circle to the other.

**Chorda Dorsa'lis**, the notochord or dorsal chord. See *Notochord*.

**Chordæ Voca'les**, the vocal chords or cords. See *Larynx*.

**Chorea** (ko-rē'a). See *Vitus's Dance*, *St.*

**Choriambus** (ko'-), in pros. a foot consisting of four syllables, of which the first and last are long, and the others short; that is, a choreus or trochee, and an iambus united.

**Chorion** (ko'ri-on), in anat. the external vascular membrane, covered with numerous villi or shaggy tufts, which invests the fetus in utero.

**Chorley** (chor'li), a municipal borough and market town, England, Lancashire. on the Chor, 20 miles N.W. of Manchester, with manufactures of cotton goods, calico-printing and dye-wood works, floor-cloth works, iron-foundries, &c. In the vicinity are coal, lead, and iron mines. Chorley gives name to a parl. div. of the county. Pop.

**Choroid** (kō'-), a term applied in anat. to

various textures; as the *choroid membrane*, one of the membranes of the eye, of a very dark colour, situated between the sclerotic and the retina, and terminating anteriorly at the great circumference of the iris.

**Chorus** (kō'rus), originally an ancient Greek term for a troop of singers and dancers, intended to heighten the pomp and solemnity of festivals. During the most flourishing period of ancient tragedy (B. C. 500-400) the Greek chorus was a troop of males and females, who, during the whole representation, were spectators of the action, never quitting the stage. In the intervals of the action the chorus chanted songs, which related to the subject of the performance. Sometimes it even took part in the performance, by observations on the conduct of the personages, by advice, consolation, exhortation, or dissuasion. In the beginning it consisted of a great number of persons, sometimes as many as fifty; but the number was afterwards limited to fifteen. The exhibition of a chorus was in Athens an honourable civil charge, and was called *choragy*. (See *Choragus*.) Sometimes the chorus was divided into two parts, who sung alternately. The divisions of the chorus were not stationary, but moved from one side of the stage to the other; from which circumstance the names of the portions of verse which they recited, *strophe*, *antistrophe*, and *epode*, are derived.—In music, the chorus is that part of a composite vocal performance which is executed by the whole body of the singers, in contradistinction to the solo airs, and concerted pieces for selected voices. The singers who join in the chorus are also called the chorus. The term is also applied to the verses of a song in which the company join the singer, or the union of a company with a singer in repeating certain couplets or verses at certain periods in a song.

**Chose** (shōz; French, a thing), in law, property; a right to possession; or that which may be demanded and recovered by suit or action at law. Thus, money due on a bond or recompense for damage done is a *chose in action*; the former proceeding from an *express*, the latter from an *implied* contract. A *chose local* is annexed to a place, as a mill or the like; a *chose transitory* is a thing which is movable.

**Chosroes** (kos'ro-es) I., surnamed the 'Just,' the greatest of the Sassanid kings of Persia, reigned A.D. 531-579. At his accession Persia was involved in a war with

the Emperor Justinian, which Chosroes terminated successfully, obliging Justinian to purchase peace by the payment of a large sum of money. In 540, however, jealous of the victories of Belisarius, the great general of the empire, Constantine violated the peace, invaded Syria, laid Antioch in ashes, and returned home laden with spoils. The war continued till 562, when the emperor again purchased peace by an annual tribute of 30,000 pieces of gold. The peace continued for ten years, when the war was renewed with Justin, the successor of Justinian, when Chosroes was again successful. The following emperor, Tiberius, at length completely defeated the Persians in 578.

**Chota Nagpore**, or CHUTIA NÁGPUR, a division of British India, presidency Bengal, divided into the districts of Lohardaga, Hazaribagh, Singbhum, and Manbhum; and nine feudatory states. Total area, 43,020 sq. miles. Pop. 4,903,991.

**Chotin** (*hō'tin*). See *Khotin*.

**Chouans** (*shō-än*), a name given to the royalist peasantry of Brittany and Lower Maine, who carried on a petty warfare against the republican government from an early period of the French revolution. The name was finally extended to all the Vendéans. The name was derived from the first chief of the Chouans, Jean Cottureau, who with his three brothers organized these bands in 1792. Cottureau had joined a band of dealers in contraband salt, and acquired the surname *Chouan* from the cry of the screech-owl (Fr. *chat-huant*) which he used as a signal with his companions. He was killed in an engagement with the republican troops in 1794. The Chouans were not suppressed till 1799, and even after that occasional spurts of insurrection occurred down till 1830, when they were finally put down.

**Chough** (*chuf*), CORNISH CHOUGH, or RED-LEGGED CROW, a bird belonging to the genus *Fregilus*, of the crow family, but nearly allied to the starlings. *F. graculus* is the only British or European species, and frequents, in England, chiefly the coasts of Cornwall. Its general colour is black, contrasting well with the vermilion-red of the beak, legs, and toes. There are other species, natives of Australia, Java, &c.

**Chretien de Troyes** (*krä'ti-en*), a French trouvère, born at Troyes about 1150, died about the end of the 12th or beginning of the 13th century. His fame rests upon six romances still extant, viz. *Iric et Guide*, *Perceval le Gallois*, *Le Chevalier au Lion*, *Cliget*,

*Chevalier de la Table ronde*, *Lancelot du lac*, and *Guillaume d'Angleterre*. Other two of his works, *Tristan, ou le Roi Marc et la Reine Yseult*, and *Le Chevalier à l'Épée*, have been apparently lost.

**Chrism** (Greek *chrisma*, salve), the holy oil prepared by the R. Catholic bishops, and used in baptism, confirmation, ordination of priests, and the extreme unction. The name is derived from the Greek word 'to anoint.'

**Chrisom** (*kris'ou*), a white garment formerly laid upon a child at baptism in token of innocence.

**Christ** (from Greek *Christos*, the anointed; *Messiah*, from the Hebrew, has the same signification), a title of our Saviour, now used almost as a name or part of his name. See *Christianity* and *Jesus Christ*.

**Christadelphians**, a religious body of recent origin, who believe that God will raise all who love him to an endless life in this world, but that those who do not shall absolutely perish in death; that Christ is the Son of God, inheriting moral perfection from the Deity, our human nature from his mother; and that there is no personal devil.

**Christchurch**, a parliamentary borough, England, county of Hampshire, 21 miles south-west of Southampton, pleasantly situated at the confluence of the Avon and Stour, about 1 mile from the sea. There is a fine old priory church, dating from the time of William Rufus, with a magnificent stone altar-screen. It sends one member to parliament, the parliamentary borough including the greater part of Bournemouth; area, 22,350 acres; pop. 1891, 53,270.

**Christchurch**, a town of New Zealand, capital of the province of Canterbury, and the see of the primate of New Zealand, is situated on the Avon River 7 miles from Port Lyttelton, with which it has railway communication. It contains a number of handsome buildings, among which are the provincial government offices, the Cathedral, St. Michael's Church, the supreme court, hospital, museum, town library, &c. There are a fine park, a botanic garden, and high-class educational and other institutions. Pop. in 1891, 16,223, or including extensive suburbs, 47,846

**Christ Church College**, OXFORD, a college projected by Cardinal Wolsey, and established in 1546 by Henry VIII. It has the patronage of above ninety livings.

**Christian**, the name of nine Danish kings. CHRISTIAN II., King of Denmark, Norway,

## CHRISTIAN ENDEAVOUR — CHRISTIANITY.

and Sweden, was born 1480, died 1559. He attained the throne in 1513, and in 1518 usurped the throne of Sweden, from which he was expelled by Gustavus Vasa in 1522. He was deposed by his Danish subjects in 1523, and retired to the Netherlands, whence he returned in 1531 with an army, but was defeated, and kept in confinement till his death.—CHRISTIAN IV., King of Denmark, son of Frederick II. and the Princess Sophia of Mecklenburg, born in Zealand in 1577, succeeded to the throne as a minor in 1588, and died 1648. In the Thirty Years' war he was beaten by Tilly at Lutter in 1626, but afterwards, in conjunction with Gustavus Adolphus, obtained the Treaty of Lübeck, 1629.

**Christian Endeavour, United Society of,** for the promotion of Christian union among Protestant denominations, originating in 1881, has now (1893) 21,080 societies and 1,370,000 members, represented in all parts of the world.

**Christian Era,** the great era now almost universally employed in Christian countries for the computation of time. It is generally supposed to begin with the year of the birth of Christ; but that event seems to have taken place four years before the present established beginning of the era. Time before Christ is marked B.C., after Christ A.D. The era is computed from the 1st Jan. in the fourth year of the 194th olympiad, and the 753d year from the building of Rome. It was first used by Dionysius, a Syrian monk, in the 6th century, but did not become general until about the middle of the 15th century.

**Christiania,** a city and port, the capital of Norway, province Aggershuus or Christiania, at the head of the long narrow inlet called Christiania Fjord, about 60 miles from the open sea or Skagerrack. The houses are mostly of brick and stone, generally plain buildings, devoid of architectural pretension. Important public buildings are the royal palace, the house of representatives or *Storting*, the governor's palace, and the cathedral. An interesting building is the fine old castle of Aggershuus, with its church and citadel crowning a point jutting out into the fjord. Attached to the university—the only one in Norway, opened in 1813—is a museum, containing a fine collection of antiquities. The manufactures of the city consist of woollen cloth, iron-ware, tobacco, paper, leather, soap, spirits, glass, &c., and there are extensive breweries.

The exports are principally timber and iron. The environs are exceedingly beautiful. Pop. 122,424.



**Christianity,** the religion instituted by Jesus Christ. Though the great moral principles which it reveals and teaches, and the main doctrines of the gospel, have been preserved without interruption, the genius of the different nations and ages have materially coloured its character. The first community of the followers of Jesus was formed at Jerusalem soon after the death of their Master. Another at Antioch in Syria first assumed (about 65) the name of *Christians*; and the travels of the apostles spread Christianity through the provinces of the Roman Empire. Palestine, Syria, Asia Minor, Greece, the islands of the Mediterranean, Italy, and the northern coast of Africa, as early as the 1st century, contained societies of Christians. At the end of the 3d century almost one-half of the inhabitants of the Roman Empire, and of several neighbouring countries, professed this belief. While Christianity as a system was thus spreading, many heretical branches had sprung from the main trunk. From the Gnostics, who date from the days of the apostles, to the Nestorians of the 5th century the number of sects was large, and some of them exist to the present day. The most important events in the subsequent history of Christianity are the separation of the Eastern and Western Churches early in the 8th century;



and the Western reformation, which may be said to have commenced with the sectaries of the 13th century and ended with the establishment of Protestantism in the 16th. The number of Christians now in the world is computed at 450,000,000. Of these about 212,000,000 are Roman Catholics, 83,000,000 belong to the Greek Church, and 155,000,000 are Protestants. Of the various sects of Protestants the most numerous are the Lutheran, the Calvinistic, and the Anglican Church.

**Christian Knowledge, SOCIETY FOR PROMOTING**, a society founded in London in 1698, in connection with the Church of England, having for its main objects the establishment of churches, schools, and libraries, and the publication and circulation of religious and moral literature. It is still in active operation, publishes a great number of religious and instructive works, and recently established a training college for schoolmistresses. In 1811 the National Society branched off from it, and has done much to further education in England in connection with the Established Church.

**Christians**, the general name of the followers of Christ. See *Christianity*.

**Christians**, or **CHRISTIAN CONNECTION**, the name of a denomination in the United States and Canada, adopted to express their renunciation of all sectarianism. They are to be met with in all parts of the country, the number of their churches being estimated at over 1000. Each church is an independent body: the Scriptures are their only rule of faith, and admission to the church is obtained by a simple profession of belief in Christianity. As a rule they are anti-Trinitarians and Baptists.

**Christiansand**, a seaport in the south of Norway, the see of a bishop, with manufactures of tobacco and machinery, brewing, &c., and a considerable export of timber and fish. Pop. 1891, 12,813.

**Christians-øe** (-eu-e), a group of three small islands in the Baltic, belonging to Denmark, named from the chief island, which has a harbour of refuge and a lighthouse.

**Christians of St. John**, a sect of religionists found in Asiatic Turkey, chiefly in the neighbourhood of Bassorah. They profess to follow the teaching of John the Baptist, and are wrongly called Christians since they reject Christ, and are practically heathens, whose deities are darkness and light. They are called also Mendean, Mendaites or Mandaites, and are also known as Sabians.

**Christians of St. Thomas**, the name of a sect of Christians on the coast of Malabar, in India, to which region the apostle St. Thomas is said to have carried the gospel. They belong to those Christians who, in the year 499, united to form a Syrian and Chaldaic church in Central and Eastern Asia, and are, like them, Nestorians.

**Christianstad**, a town, Sweden, capital of the län or government of same name, on a peninsula in the Helge Lake, about 10 miles from the Baltic, with manufactures of gloves, linen and woollen fabrics, and some trade through the port of Åhus, at the mouth of the Helge. Pop. 1891, 10,670.

**Christiansted**, a fortified town, capital of the island of St. Croix, Danish West Indies, with a good harbour and some trade. Pop. 9600.

**Christiansund**, a seaport town on the N.W. coast of Norway, 82 miles S.W. of Trondhjem, on three islands which inclose its beautiful landlocked harbour, with a trade in dried and salted fish. Pop. 8251.

**Christina**, Queen of Sweden, daughter of Gustavus Adolphus, born 1626, died 1689. After the death of Gustavus, at Lützen, in 1632, the states-general appointed guardians to the Queen Christina, then but six years old. Her education was continued according to the plan of Gustavus Adolphus. She learned the ancient languages, history, geography, politics, and renounced the pleasures of her age in order to devote herself entirely to study. In 1644 she took upon herself the government. A great talent for business, and great firmness of purpose, distinguished her first steps. She terminated the war with Denmark begun in 1644, and obtained several provinces by the treaty concluded at Bromsebro in 1645. Her subjects wished that she should choose a husband, but she manifested a constant aversion to marriage. During this time her patronage of learned men, artists, and the like, was lavish. In 1650 she caused herself to be crowned with great pomp, and with the title of *king*. From that time a striking change in her conduct was perceptible. She neglected her ancient ministers, and listened to the advice of ambitious favourites. Intrigues and base passions succeeded to her former noble and useful views. The public treasure was squandered with extravagant profusion. In 1654 she abdicated in favour of her cousin Charles Gustavus, reserving to herself a certain income, entire independence, and full power over her suite and

household. A few days after she left Sweden and went to Brussels, where she made a public entry and remained for some time. There she made a secret profession of the Catholic religion, which she afterwards publicly confirmed in Innsbruck. From Innsbruck she went to Rome, which she entered on horseback in the costume of an Amazon, with great pomp. When the Pope Alexander VII. confirmed her she adopted the surname of *Alessandra*. For some time she resided at Paris, and incurred great odium by the execution of her Italian equerry Monaldeschi for betrayal of confidence. Subsequent attempts which she made to resume the crown of Sweden failed, and she spent the rest of her life in artistic and other studies at Rome. She left an immense art collection and a large number of valuable MSS. Her writings were collected and published in 1752.

**Chris'tison**, SIR ROBERT, Bart., eminent physician, born at Edinburgh 1797, died 1882. A specialist in toxicology, he was appointed to the chair of medical jurisprudence in Edinburgh in 1822, and in 1832 he was promoted to that of materia medica. He was twice president of the Royal College of Physicians, president of the Royal Society of Scotland, and ordinary physician to the Queen in Scotland. He was D.C.L. of Oxford and LL.D. of Edinburgh, and was elected rector of the latter university in 1880.

**Christmas** (kris'mas), the festival of the Christian church observed annually on 25th December in memory of the birth of Christ, and celebrated by a particular church service. The time when the festival was first observed is not known with certainty; but it is spoken of in the beginning of the 3d century by Clement of Alexandria, and in the latter part of the 4th century Chrysostom speaks of it as of great antiquity. As to the day on which it was celebrated, there was long considerable diversity, but by the time of Chrysostom the Western Church had fixed on the 25th of December, though no certain knowledge of the day of Christ's birth existed. The Eastern Church, which previously had generally favoured the 6th of January, gradually adopted the same date. Many believe that the existence of heathen festivals celebrated on or about this day had great influence on its being selected; and the Brumalia, a Roman festival held at the winter solstice, when the sun is as it were born anew, has often been instanced as having a strong bearing on the question.

In the R. Catholic, Greek, Anglican, and Lutheran churches, there is a special religious service for Christmas day; and, contrary to the general rule, a R. Catholic priest can celebrate three masses on this day. Most other churches hold no special service, but almost everywhere throughout Christendom it is kept as a holiday and occasion of social enjoyment.

**Christmas-boxes**, boxes in which presents were deposited at Christmas; hence a Christmas gift. The custom of bestowing Christmas-boxes arose in the early days of the church, when boxes were placed in the churches for the reception of offerings; these boxes were opened on Christmas-day, and their contents distributed by the priests on the morrow (boxing-day).

**Christmas Cards**, ornamental cards containing words of Christmas greeting to friends to whom they are sent. The first of them appeared about 1862, and consisted of pictures of robins, holly, &c.; since then highly artistic designs have been introduced, and their manufacture is considerable in the United States, Germany, France, and England. Immense quantities of them pass through the post-office every Christmas.

**Christmas Carol**, a carol or song descriptive of the birth of Christ, or of incidents connected with it, sung specially at Christmas.

**Christmas Rose**, the *Helleborus niger* (black hellebore), so called from its flower, which resembles a large white single rose; its foliage is dark and evergreen, and the plant blossoms during the winter months.



Christmas Rose (*Helleborus niger*).

**Christmas Tree**, a small fir-tree lighted up by means of tiny candles of coloured wax or small Chinese lanterns, ornamented with flags, tinsel ornaments, &c., and hung all over with gifts for children.

**Christology**, that branch of the study of divinity which deals directly with the doctrine of the person of Christ.

**Christophe** (kris-tof), HENRI, King of Hayti, was born in the West Indies in 1767, and was employed as a slave in St. Domingo on the outbreak of the blacks against the French in 1793. From the commencement

of the troubles he signalized himself by his energy, boldness, and activity in many bloody engagements. Toussaint-L'Ouverture gave him the commission of brigadier-general, and he was largely instrumental in driving the French from the island. After the death of Dessalines Christophe became master of the northern part of the island. In 1811 he had himself proclaimed King of Hayti by the name of Henri I. He also sought to perpetuate his name by the compilation of the Code Henri—a digest founded upon the Code Napoleon. His cruelty provoked a revolt, which being unable to quell he shot himself, 1820.

**Chris'topher, St.**, a martyr of the early church, beheaded in Asia Minor, according to tradition in the year 250. The Eastern Church celebrates his festival on the 9th of May, the Western on the 25th of July.

**Christopher's, St.** (commonly called *St. Kitt's*), a British island in the West Indies, one of the Leeward Islands, 23 miles in length, and in general about 5 in breadth; area 68 sq. miles, or 44,000 acres, of which about 17,000 acres are appropriated to the growth of sugar, and 4000 to pasturage. The interior consists of many rugged precipices and barren mountains. Of these the loftiest is Mount Misery (evidently an extinguished volcano), 4100 feet high. The chief town, a seaport with open roadstead, is Basse-Terre. The island has a legislature of its own, with an executive subordinate to the governor of the Leeward Islands, resident in Antigua. It was discovered by Columbus in 1493 and colonized by the English in 1623. Pop. 29,127.

**Christopu'los, ATHANASIOS**, the best of modern Greek lyric poets, born in 1772 at Kastoria, in Macedonia; died 1847. His reputation as a poet rests on his *Erotika* and *Bacchika*, or Love and Drinking Songs, which have been several times collected and printed under the title of *Lyrika*. He is also the author of an *Æolian-Doric* grammar, and translated into modern Greek parts of the *Iliad* and of *Herodotus*.

**Christ's College**, one of the colleges of the University of Cambridge, founded originally by Henry VI., but remodelled and liberally endowed by Margaret, Countess of Richmond and Derby, mother of Henry VII., in 1505.

**Christ's Hospital** (generally known by the name of *Blue-coat School*, the title having reference to the costume of the children educated there), a school in London, founded

by Edward VI. for supporting poor orphans. Its present income is about £70,000 annually; the education is essentially classical, but modern languages, literature, &c., are also taught. There is a mathematical school attached, and scholarships are given either to Oxford or Cambridge. The average number of pupils in London and at the preparatory school at Hertford, which includes girls, is upwards of 1000. The London School occupies the site of the old Greyfriars monastery. Here Camden, Richardson the novelist, Coleridge, Charles Lamb, and Leigh Hunt received their education.

**Christ's Thorn**, the *Paliurus aculeatus*, a small thorny shrub, order Rhamnaceæ, with small shining ovate leaves and yellowish-green clustered flowers. It is common in the south-east of Europe and Asia Minor, and some suppose it to have been the plant from which the Jews platted the crown of thorns for our Saviour. See also *Jujube*.

**Chromate**. See *Chrome Iron Ore*, *Chrome Yellow*.

**Chromat'ic**, in music, a term applied to notes and peculiarities not belonging to the diatonic scale. Thus a *chromatic chord* is a chord which contains a note or notes foreign to diatonic progression; *chromatic harmony*, harmony consisting of chromatic chords. The *chromatic scale* is a scale made up of thirteen successive semitones, that is, the eight diatonic tones and the five intermediate tones.

**Chromatic Printing**. See *Colour Printing*.

**Chromat'ics**, the science of colours; that part of optics which treats of the properties of the colours of light and of natural bodies.

**Chrome Green** (krōm), the green oxide or sesquioxide of chromium, forming a green pigment used by enamellers.

**Chrome Iron Ore**, an ore of chromium, is a mineral of very considerable importance as affording chromate of potash, whence are obtained various other preparations of this metal used in the arts.

**Chrome Yellow**, a chromate of lead, a beautiful pigment, varying in shade from deep orange to very pale canary yellow, much used in the arts.

**Chro'mium** (chemical symbol, Cr.; atomic weight, 52.4), a metal which forms very hard steel-gray masses; it never occurs native, but may be obtained by reducing the oxide. In its highest degree of oxidation it forms a compound of a ruby-red colour. By itself it has received no practical appli-

cations. It takes its name from the various and beautiful colours which its oxide and acid communicate to minerals into whose composition they enter. It is the colouring matter of the emerald and beryl. Chromium is employed to give a fine deep green to the enamel of porcelain, to glass, &c. The oxide of chromium is of a bright grass-green or pale-yellow colour. This element was originally discovered in 1797 by Vauquelin, in the native chromate of lead of Siberia. See preceding articles.

**Chromo-lithography**, a method of producing a coloured or tinted lithographic picture, by using various stones having different portions of the picture drawn upon them with inks of various colours and so arranged as to blend into a complete picture. Sometimes as many as twenty different colours are employed. In printing, the lighter shades are printed off first and the darkest last.

**Chro'mosphere**, the name given to the gaseous envelope which exists round the body of the sun, through which the light of the photosphere, an inner envelope of incandescent matter, passes. During total eclipses it had been observed that a red-coloured envelope surrounded the sun, shooting up to great distances from the surface. It seems to have been first recognized by Secchi; and the projecting portions of it are commonly described as 'red-coloured protuberances' and 'red flames.' To this red envelope the name *chromosphere* was given by Mr. Lockyer. The light from it is much fainter than that from the photosphere; and till 1868, when M. Janssen and Mr. Lockyer almost simultaneously pointed out a method of viewing it, it was never seen except during eclipses. The chromosphere and its prominences, when examined with the telescope, exhibit a spectrum of bright lines, due to incandescent gases. The most elevated portions consist entirely or almost entirely of hydrogen, the lightest of the gases. Lower down are found the gases or vapours of the heavier metals—of sodium, magnesium, barium, iron, and others. The lower the layer of the chromosphere examined the more densely is the spectrum filled with lines of metals, and in the prominences the red hydrogen flames tower high above all.

**Chronic** (from Greek *chronos*, time), a term applied to diseases which are inveterate or of long continuance, in distinction to *acute* diseases, which speedily terminate.

**Chron'icle**, a history digested according to the order of time. In this sense it differs but little from *annals*. The term is mostly used in reference to the old histories of nations written when they were comparatively rude. The histories written in the middle ages, some in verse, some in prose, are known as chronicles. Well-known examples are the works of Froissart, Monstrelet, Fabian, Hardyng, Hall, Hollinshed, Stowe, and Baker.

**Chron'icles**, BOOKS OF, two books of the Old Testament which formed only one book in the Hebrew canon, in which it is placed last. Its division into two parts is the work of the *Seventy*. (See *Septuagint*.) The Hebrew name means 'acts of the days,' and is thus much the same as our 'journals.' The title given to it by the Seventy was *Paraleipomena*, meaning 'things omitted.' The name Chronicles was given to it by Jerome. The book is one of the latest compositions of the Old Testament, and is supposed to have been written by the same hand as Ezra and Nehemiah. According to its contents the book forms three great parts:—1, genealogical tables; 2, the history of the reigns of David and Solomon; 3, the history of the kingdom of Judah from the separation under Rehoboam to the Babylonian captivity, with a notice in the last two verses of the permission granted by Cyrus to the exiles to return home and rebuild their temple. The Chronicles present many points of contact with the earlier scriptures, historical and prophetic, more especially, however, with the books of Samuel and of Kings.

**Chron'ogram**, a device by which a date is given in numeral letters by selecting certain letters of an inscription and printing them larger than the others, as in the motto of a medal struck by Gustavus Adolphus in 1632:—ChrIstVs DVX; ergo trIVMphVs; where the values of C and the other capitals regarded as Roman numerals gives the required figure when added together.

**Chron'ograph**, the name given to various devices for measuring and registering very minute portions of time with extreme precision. Benson's chronograph is, in principle, a lever watch with a double seconds hand, the one superimposed on the other. The outer end of the lowermost hand has a small cup filled with a black viscid fluid, with a minute hole at the bottom, while the corresponding end of the uppermost is bent down so as just to reach the hole. At the

starting (say) of a horse-race, the observer pulls a string, whereupon the bent end of the upper hand passes through the hole and makes a black mark on the dial, instantly rebounding. Again, as each horse passes the winning-post the string is redrawn and a dot made, and thus the time occupied by each horse is noted. This chronograph registers to one-tenth of a second. Strange's chronograph is connected with the pendulum of an astronomical clock, which makes a mark on a sheet of paper at the beginning and end of each swing. By touching a spring on the appearance (say) of a particular star in the field of a telescope, an additional dot is made intermediate between the two extreme ones, and by measuring the distance of this from either of these extremes the exact time can be ascertained to one-hundredth of a second. Schultze's chronograph, in which electricity is applied, is yet far more precise, registering time to the five-hundred-thousandth part of a second.

**Chronol'ogy** (Gr. *chronos*, time, and *logos*, discourse), the science which treats of time, and has for its object the arrangement and exhibition of historical events in order of time and the ascertaining of the intervals between them. Its basis is necessarily the method of measuring or computing time by regular divisions or periods, according to the revolutions of the earth or moon. The motions of these bodies produce the natural division of time into years, months, and days. As there can be no exact computation of time or placing of events without a fixed point from which to start, dates are fixed from an arbitrary point or *epoch*, which forms the beginning of an *era*. The more important of these are the creation of the world among the Jews; the birth of Christ among Christians; the Olympiads among the Greeks; the building of Rome among the Romans; the Hejira or flight of Mohammed among the Mohammedans, &c. See *Epoch, Calendar*.

**Chronom'eter**, any instrument that measures time, as a clock, watch, or dial; but, specifically, this term is applied to those time-keepers which are used for determining the longitude at sea, or for any other purpose where an accurate measure of time is required, with great portability in the instrument. The chronometer differs from the ordinary watch in the principle of its escapement, which is so constructed that the balance is free from the wheels during the greater part of its vibration, and also in be-

ing fitted with a 'compensation adjustment,' calculated to prevent the expansion and contraction of the metal by the action of heat and cold from affecting its movements. Marine chronometers generally beat half-seconds, and are hung in gimbals in boxes 6 or 8 inches square. The pocket chronometer does not differ in appearance from a watch except that it is somewhat larger.

**Chron'oscope**, an instrument for measuring the duration of extremely short-lived phenomena, such as the electric spark; more especially the name given to instruments of various forms for measuring the velocity of projectiles.

**Chrudim** (*hrö'dim*), a town, Bohemia, 62 miles S.E. of Prague, with some manufactures and large horse-markets. Pop. 11,886.

**Chrys'alis**, a form which butterflies, moths, and most other insects assume when they change from the state of larva or caterpillar and before they arrive at their winged

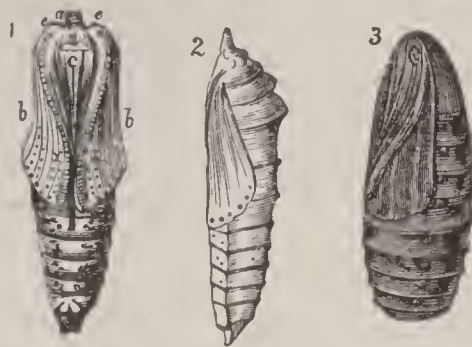

1, 2, Chrysalis of the White Butterfly-moth: *a*, Palpi or feelers; *b b*, wing-cases; *c*, sucker; *e e*, eyes; *x x*, antennæ. 3, Chrysalis of the Oak Egger-moth.

or perfect state. In the chrysalis form the animal is in a state of rest or insensibility, and exists without nutriment, the length of time varying with the species and season. During this period an elaboration is going on in the interior of the chrysalis, giving to the organs of the future animal their proper development.

**Chrysan'themum**, a large genus of composite plants, consisting of herbs or shrubs with single, large-stalked yellow flowers or with many small flowers; the rays are sometimes white. Two species are common weeds in Britain, *C. Leucanthëmum* (the ox-eye daisy), a meadow plant with white ray-flowers, and *C. segëtum* (the corn-marigold), a corn-field weed with golden-yellow ray-flowers. The chrysanthemum of gardens is a Chinese half-shrubby plant (*C. sinense*), whose numerous varieties constitute one of the chief ornaments of our American gardens in October, November, and December.

**Chryselephan'tine** (Gr. *chrysos*, gold, *elephas*, ivory), made of gold and ivory combined, a term applied to statues executed in these two substances by the ancient Greeks, as Pheidias's great statue of Athena.

**Chrysip'pus**, an ancient Greek philosopher belonging to Cilicia, lived about B.C. 282-209. He was the principal opponent of the Epicureans, and is said to have written 700 different works, mostly of a dialectical character; but only a variety of fragments are extant.

**Chrys'oberyl** (sometimes called *cymophane*, and, by the jewellers, *oriental chrysolite*), a gem, of a dilute yellowish-green colour, usually found in round pieces about the size of a pea, but also crystallized in eight-sided prisms. It is an aluminate of beryllium, is next to the sapphire in hardness, and is employed in jewelry, the specimens which present an opalescent play of light being especially admired.

**Chrys'olite**, a mineral composed of silica, magnesium, and iron. Its prevailing colour is some shade of green. It is harder than glass, but less hard than quartz; often transparent, sometimes only translucent. Very fine specimens are found in Egypt and Brazil, but it is not of high repute as a jeweller's stone.

**Chrysol'o'ras**, MANUEL, a distinguished Greek of Constantinople, born about the middle of the 14th century, died 1415. He settled as a teacher of Greek literature at Florence, about 1395. He also taught at Milan, Pavia, and Rome, thus becoming a chief promoter of the great revival of learning.

**Chrysophan'ic Acid**, the yellow colouring matter of rhubarb. With potash it gives a fine purple solution, and thus affords a delicate test for the presence of alkalis.

**Chrys'oprase**, a kind of quartz, being merely a variety of chalcedony. Its colour is commonly apple-green, and often extremely beautiful, so that it is much esteemed in jewelry. It is translucent, or sometimes semi-transparent, and of a hardness little inferior to that of flint.

**Chrys'ostom**, JOHN, ST. ('golden-mouthed'), a celebrated Greek father of the church, born in Antioch about A.D. 344, died at Comana in Pontus 407. Secundus, his father, who had the command of the imperial troops in Syria, died soon after the birth of his son, whose early education devolved upon Anthusa, his mother. Chrysostom studied eloquence with Libanius, the most

famous orator of his time, and soon excelled his master. After having studied philosophy with Andragathius he devoted himself to the Holy Scriptures, and determined upon quitting the world and consecrating his life to God in the deserts of Syria. He spent several years in solitary retirement, studying and meditating with a view to the church. Having completed his voluntary probation he returned to Antioch in 381, when he was appointed deacon by the Bishop of Antioch, and in 386 consecrated priest. He was chosen vicar by the same dignitary, and commissioned to preach the Word of God to the people. He became so celebrated for the eloquence of his preaching that the Emperor Arcadius determined, in 397, to place him in the archiepiscopal see of Constantinople. He now exerted himself so zealously in repressing heresy, paganism, and immorality, and in enforcing the obligations of monachism, that he raised up many enemies, and Theophilus, patriarch of Alexandria, aided and encouraged by the Empress Eudoxia, caused him to be deposed at a synod held at Chalcedon. The emperor banished him from Constantinople, and Chrysostom purposed retiring to Bithynia; but the people threatened a revolt. In the following night an earthquake gave general alarm. In this dilemma Arcadius recalled his orders, and Eudoxia herself invited Chrysostom to return. The people accompanied him triumphantly to the city, his enemies fled, and peace was restored, but only for a short time. A feast given by the empress on the consecration of a statue, and attended with many heathen ceremonies, roused the zeal of the archbishop, who publicly exclaimed against it; and Eudoxia, violently incensed, recalled the prelates devoted to her will, and Chrysostom was condemned and exiled to Armenia. Here he continued to exert his pious zeal until the emperor ordered him to be conveyed to a town on the most distant shore of the Black Sea. The officers who had him in charge obliged the old man to perform his journey on foot, and he died at Comana, by the way. Here he was buried; but in 438 his body was conveyed solemnly to Constantinople, and there interred in the Church of the Apostles, in the sepulchre of the emperor. At a later period his remains were placed in the Vatican at Rome. The Greek Church celebrates his feast on the 13th of November, the Roman on the 27th of January. His works, which consist of sermons, commen-

aries, and treatises, abound with information as to the manners and characteristics of his age.

**Chub**, a European river fish, of the genus *Cyprinus* or carps; or, as some regard it, of the sub-genus *Leuciscus* (*L. cephalus*). The body is oblong, nearly round; the head and

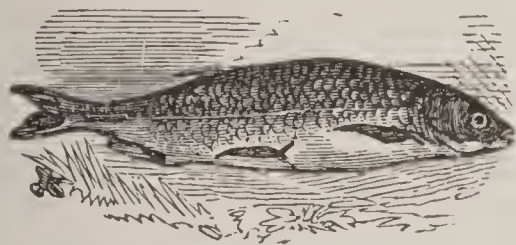

Chub (*Cyprinus* (*Leuciscus*) *cephalus*).

back green, the sides silvery, and the belly white. It frequents deep holes in rivers shaded by trees, but in warm weather floats near the surface, and furnishes sport for anglers. It is indifferent food, and rarely attains the weight of 5 lbs. Allied American species receive the same name.

**Chubb**, THOMAS, English writer, born in 1679, died in 1746. Although engaged as a glover and chandler he gave his chief attention to philosophical and theological study, and was celebrated in the Arian controversy for his argumentative keenness. In this connection he published in 1715 *The Supremacy of the Father Asserted*, besides various other moral and theological tracts.

**Chubb-lock**, a lock so named from the name of its inventor, a London locksmith. It has more tumblers than usual, with the addition of a lever called the detector, which is so fixed that while it does not act under the ordinary application of the key, yet cannot fail to move if any one of the tumblers be lifted a little too high, as must be the case in any attempt at picking. This movement fixes the bolt immovably, and renders all further attempts at picking useless.

**Chuck-Will's-Widow**, a popular name in the U. S. for a bird of the goat-sucker family, *Antrostomus carolinensis*, so called from its cry.

**Chum'bul**, a river of N. W. Hindustan, which rises in the Vindhya Mountains, and falls into the Jumna about 90 miles south-east of Agra, after a course of 650 miles.

**Chunam'**, in the East Indies a name given to a very fine kind of quicklime made from calcined shells or from very pure limestone, and used for chewing with betel and for plaster.

**Chunar** (*chu-när'*), a town and fortress,

Hindustan, North-west Provinces, 26 miles south-west of Benares, on the Ganges. The fortress stands on a lofty rock rising abruptly from the river. Pop. 9148.

**Chuprah**, or CHAPRA (*chap-rä'*), a town, Hindustan, division of Bahar, on the Gogra, about a mile above its confluence with the Ganges; extending along the river for nearly four miles, with an active trade in cotton, sugar, and saltpetre. Pop. 1891, 57,352.

**Chuquisaca** (*chö-kē-sä'ká*), or SUCRE, a city of South America, the capital of Bolivia; well situated on a plateau between the Amazon and La Plata rivers, 9343 feet above sea-level. It has a cathedral and a university. It was founded by one of Pizarro's officers in 1539. Pop. formerly 27,000, now estimated 12,000.—The province of Chuquisaca has an area of 39,871 square miles; a pop. of 123,347.

**Chur** (*hör*), the capital of the Swiss canton of Grisons. See *Coire*.

**Church** (from Gr. *kyriakon*, from *kyrios*, 'lord'), a word which in its widest sense denotes the whole community of Christians, and was thus used by the New Testament writers. In more restricted significations it denotes a particular section of the Christian community differing in doctrinal matters from the remainder, as the Roman Catholic Church, the Protestant Church, &c.; or to designate the recognized leading church of a nation, as the English, Scotch, or French Church. In yet another sense it signifies the edifice appropriated to Christian worship. After the conversion of Constantine the basilicæ or public halls and courts of judicature and some of the heathen temples were consecrated as Christian churches. When churches came to be specially built for Christian worship their forms were various—round, octagonal, &c. Later on the form with the cross aisle or transept (*cruciform* churches) became common. Early British churches were built of wood; the first stone churches erected being that of Whit-horn, Galloway (6th century), and that of York (7th century). The accompanying illustrations exhibit a type of church which with more or less modification is common in England, and will enable the reader to understand the terms applied to the various parts. (See also *Cathedral*.) Generally speaking any building set apart for religious ordinances is called a church, though when of a minor kind it is usually designated a *chapel*. The term church, however, is often restricted to the buildings for worship connected with

a national establishment. They are classed as *cathedral*, when containing a bishop's throne; *collegiate*, when served by a dean and chapter;

*conventual* or *minster*, when connected with a convent or monastery; *abbey* or *priory*, when under an abbot or prior;



Islip Church, Northamptonshire.

1, Eastern end and great east window. 2, Chancel and its windows. 3, End of nave. 4 4 4, Clerestory and its windows. 5, South aisle. 6, South porch. 7, Tower. 8, Belfry windows. 9, Spire.

and *parochial*, when the charge of a secular priest. See *Christianity*, *Greek Church* & c.

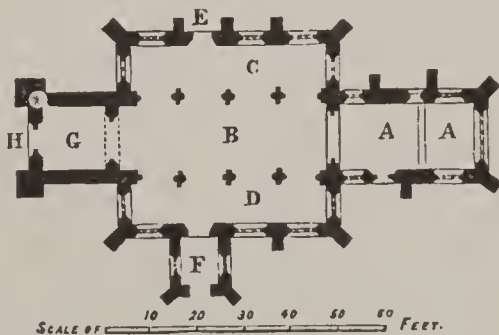

Plan of Islip Church.

A A, Chancel. B, Nave. C, North aisle. D, South aisle. E, North door. F, South porch. G, Tower. H, West door.

**Church, FATHERS OF THE** (*patres ecclesiae*), teachers and writers of the ancient church who flourished after the time of the apostles and apostolic fathers (the immediate disciples of the apostles), from the 2d to the 6th century. The most celebrated among the Greek fathers are Clement of Alexandria, Origen, Eusebius, Athanasius, and Chrysostom. The most distinguished among the Latin fathers are Tertullian, Augustine, Ambrose, and Jerome.

**Church, STATES OF THE.** See *Papal States*.  
**Churchill, CHARLES**, English poet and satirist, was born in 1731 and died in 1764. He was educated at Westminster School, but made so bad a use of his time that he was refused admission to the University of Oxford. An early and imprudent marriage was soon followed by his admission to holy orders and a Welsh curacy of £30 a year. On the death of his father he obtained his curacy of St. John's, Westminster; but owing to his love of gaiety he was soon overwhelmed with debt, and had to compound with his creditors. In 1761 he published anonymously a poem called *The Rosciad*, a clever satire on the chief actors of the day. Its success was increased by the vehemence with which the players replied to it, and Churchill seized the opportunity of giving the town a new satire, *The Apology*. A course of dissipation and intemperance followed, which excited much animadversion, and elicited from him his next satire, *Night*. Churchill now threw aside all regard for his profession, and became a complete man about town and a professional political satirist. His other productions include *The Ghost*, in which Dr. Johnson is satirized; *The Prophecy of Famine*, directed against the Scotch; an *Epistle to Hogarth*, the *Conference*, the *Duellist*, the *Candidate*, and the *Journey*.

**Churchill, RANDOLPH HENRY SPENCER, LORD**, second son of the sixth Duke of Marlborough, born 1849. Having entered parliament in 1874, by 1884 he had risen to the position of a recognized leader of the Conservative party, and in 1885 became Indian secretary in Lord Salisbury's government. On the defeat of Gladstone's Irish Bill in 1886 Churchill became leader of the House of Commons and Chancellor of the Exchequer, posts which he unexpectedly resigned in December 1886. Died in 1895.

**Churchill River**, a river of the Northwest Territories of Canada, which rises in La Crosse Lake, forms or passes through various lakes or lake-like expansions, the largest being Big or Indian Lake, and enters Hudson's Bay after a north-easterly course of about 800 miles. It is called also Mississippi or English river.

**Churching of Women**, a form of thanksgiving after child-birth, adopted from the Jewish ceremony of purification, and practised still in the Roman Catholic and Anglican Churches, the latter having a special service in the Prayer Book.



**Church of England.** See *England*.

**Church of Scotland.** See *Scotland*.

**Church-rate**, in England a rate raised by resolutions of a majority of the parishioners in vestry assembled, from the occupiers of land and houses within a parish, for the purpose of maintaining the church and its services. In 1868 an act was passed abolishing compulsory church-rates, except such as, under the name of church-rates, were applicable to secular purposes.

**Churchwar'dens**, officers, generally two for each parish in England, who superintend the church, its property and concerns. They are annually chosen by the minister and parishioners, according to the custom of each parish.

**Churchyard**, the ground in which the dead are buried, adjoining to a church.

**Churchyard Beetle**, the *Blaps mortisāga*, a very common insect found in dark, damp, and dirty places; it is black, but little shining, and the tip of the elytra forms a short obtuse point.

**Churn**, a vessel for preparing butter from cream or milk, in which cream is agitated to separate its buttery globules in a solid mass from the fluid portions. Churns are made of various forms: in a very common kind a perforated circular board is made to move up and down in a vessel containing the cream, and having the shape of the frustum of a cone, by means of a long stalk or rod fixed to it, called the churn-staff. In others the churning is performed by a circular motion. Very large churns are worked by steam or horse power.

**Churrus.** See *Charras*.

**Churubusco** (chū-rū-bus'kō), a village 6 miles s. of Mexico, the scene of a battle between the Mexicans and Santa Anna, and the Americans under Scott, 20th Aug. 1847, in which the former were defeated.

**Chu'san Islands**, a group of islands on the east coast of China, the largest in the archipelago having the name Chusan, and being about 21 miles long, and from 6 to 11 broad. Pop. about 200,000. Chief town Ting-hae, pop. 40,000. Rice and tea are the principal products. From its situation near the mouths of the Yang-tse-kiang, which river forms the great channel of communication with the capital of the empire, Chusan is considered as the key of China, and was temporarily taken possession of by the British in 1840, 1841, and 1860. The sacred island of Pu-tu to the east of the above is covered with Buddhist temples, monasteries, &c., and is entirely inhabited by priests.

**Chutia Nagpur.** See *Chota Nagpore*.

**Chut'ny**, or CHUTNEE, in the East Indies a condiment compounded of sweets and acids. Ripe fruit (mangoes, raisins, &c.), spices, sour herbs, cayenne, lemon-juice, are the ordinary ingredients. They are pounded and boiled together, and then bottled for use.

**Chyle** (kīl), in physiology, a white or milky fluid separated from aliments by means of digestion. Chyle is found in the intestines after the food has been mixed with the bile and pancreatic juice. It is absorbed by the lacteal vessels, terminating in the inner surface of the small intestines, chiefly the jejunum, and thence passes by numerous converging streams into the main trunk of the absorbent system, called the thoracic duct, through which it is gradually poured into the blood of the left subclavian vein at a short distance before it enters the right side of the heart. The chemical constituents of chyle are nearly the same as those of the blood itself.

**Chyme** (kīn), food after it has been digested in the stomach. In the stomach it forms a pulpy mass which passes on into the small intestine, and being acted on by the bile, pancreatic fluid, and intestinal juice, is separated into chyle and non-nutritious matters, which latter are carried off by the evacuations.

**Cibber**, COLLEY, a dramatic writer and actor, born in London 1671, died 1757. He took to the stage in 1689. His first dramatic effort, *Love's Last Shift*, appeared in 1695; and it was followed by *Woman's Wit*, the *Careless Husband*, and the *Non-juror*, of which the *Hypocrite* of the modern stage is a new version. A court pension and the appointment of poet-laureate drew upon him the rancour of the wits and poets of the day, including Pope. He is author of about twenty-five dramas, the amusing *Apology for the Life of Colley Cibber*, &c.—His son THEOPHILUS, born in 1703, drowned in his passage to Ireland 1757, was an actor and dramatic writer. He was much inferior to his father in capacity.—SUSANNA MARIA, wife of Theophilus Cibber, born 1716, died 1766, was one of the best actresses on the English stage. She was sister of Dr. Arne (composer of *Rule, Britannia*), who taught her music, and introduced her in one of his operas at the Haymarket Theatre. Handel composed pieces expressly adapted to her voice, and used to instruct her in singing them. She subsequently made her appearance in tra-

gedy, and gained universal admiration. Garrick is said to have exclaimed, when informed that she was dead, 'Then tragedy has expired with her.'

**Cib'ol** (*Allium fistulosum*), a perennial plant of the onion genus, a native of Siberia, with hollow stems larger than those of the chive: used for culinary purposes.

**Cibo'rium**, in the R. Catholic Church, a kind of cup or chalice made of gold or silver and containing the bread used in the sacrament. Also a sort of canopy over an altar.

**Cica'da**, the popular and generic name of certain insects belonging to the order Hemiptera, sub-order Homoptera, of many species. The males have on each side of the body a kind of drum, with which they can make a considerable noise. This, regarded as the insect's song, was much admired by the ancients, and is frequently referred to by their poets. The largest European species are about an inch long, but some American species are much larger, and can be heard a mile off. They are nearly all natives of tropical or warm temperate regions. The female has the posterior extremity of the abdomen furnished with two serrated horny plates, by means of which it pierces the branches of trees to deposit its eggs. An English species (*C. anglica*) is found in the New Forest. The seven years' locust (*Cicāda septemdecim*) is well known in the U. States.

**Cicala** (chi-kā'lā). The cicada.

**Cicely** (sis'e-li), a popular name applied to several umbelliferous plants. Sweet cicely, or sweet chervil, is *Myrrhis odorāta*, a plant common in Britain and in other parts of Europe. It was formerly used in medicine, and in some parts of Europe is used as an ingredient in soups. Sweet cicely is found in our woods from Canada to Virginia.

**Cicero**, MARCUS TULLIUS, the greatest Roman orator, was born 106 B.C. at Arpinum. His family was of equestrian rank, and his father, though living in retirement, was a friend of some of the chief public men. He received the best education available, studied philosophy and law, became familiar with Greek literature, and acquired some military knowledge from serving a campaign in the Marsic war. At the age of twenty-five he came forward as a pleader, and having undertaken the defence of Sextus Roscius, who was accused of parricide, procured his acquittal. He visited Greece B.C. 79, conversed with the philosophers of all the schools, and profited by the instruction

of the masters of oratory. Here he formed that close friendship with Atticus of which his letters furnish such interesting evidence. He also made a tour in Asia Minor and remained some time at Rhodes, where he visited the most distinguished orators and took part in their exercises. On his return to Rome his displays of eloquence proved the value of his Grecian instruction, and he became one of the most distinguished orators in the forum. In B.C. 76 he was appointed quæstor of Sicily, and behaved with such justice that the Sicilians gratefully remembered him and requested that he would conduct their suit against their governor Verres. He appeared against

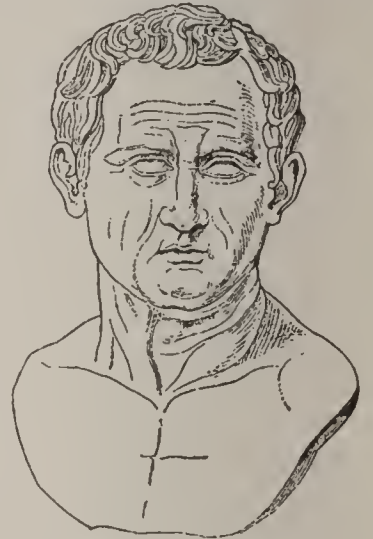

Cicero.—Antique bust.

this powerful robber, and the crimes of Verres were painted in the liveliest colours in his immortal speeches. Seven of the Verrine orations are preserved, but only two of them were delivered, and Verres went into voluntary exile. After this suit Cicero was elected to the office of ædile, B.C. 70, became prætor in 67, and consul in 63. It was now that he succeeded in defeating the conspiracy of Catiline (see *Catiline*), after whose fall he received greater honours than had ever before been bestowed upon a Roman citizen. He was hailed as the saviour of the state and the father of his country (*parens patriæ*), and thanksgivings in his name were voted to the gods. But Cicero's fortune had now reached the culminating point, and soon was to decline. The Catilinarian conspirators who had been executed had not been sentenced according to law, and Cicero, as chief magistrate, was responsible for the irregularity. Publius Clodius, the tribune of the people, raised such a storm against him that he was obliged to go into exile (B.C. 58). On the fall of the Clodian faction he was recalled to Rome, but he never succeeded in regaining the influence he had once possessed. In B.C. 52 he became proconsul of Cilicia, a province which he administered with eminent success. As soon as his term of office had expired he

returned to Rome (Jan. B.C. 49), which was threatened with serious disturbances owing to the rupture between Cæsar and Pompey. He espoused the cause of Pompey, but after the battle of Pharsalia he made his peace with Cæsar, with whom he continued to all appearance friendly, and by whom he was kindly treated, until the assassination of the latter (44 B.C.). He now hoped to regain his political influence. The conspirators shared with him the honour of an enterprise in which no part had been assigned him; and the less he had contributed to it himself the more anxious was he to justify the deed and pursue the advantages which it offered. Antony having taken Cæsar's place, Cicero composed those admirable orations against him, delivered in B.C. 43, which are known to us by the name of *Philippics* (after the speeches of Demosthenes against Philip of Macedon). His implacable enmity towards Antony induced him to favour young Octavianus, who professed to entertain the most friendly feelings towards him. Octavianus, however, having possessed himself of the consulate, and formed an alliance with Antony and Lepidus, Cicero was proscribed. In endeavouring to escape from Tusculum, where he was living when the news of the proscription arrived, he was overtaken and murdered by a party of soldiers; and his head and hands were publicly exhibited in the forum at Rome. He died in his sixty-fourth year, B.C. 43. Cicero's eloquence has always remained a model. After the revival of learning he was the most admired of the ancient writers; and the purity and elegance of his style will always place him in the first rank of Roman classics. His works, which are very numerous, consist of orations; philosophical, rhetorical, and moral treatises; and letters to Atticus and other friends. The life of Cicero was written by Plutarch, and there are modern lives by Middleton, Forsyth, and others. Cicero left a son of the same name by his wife Terentia. Young Marcus was born in B.C. 65, was carefully educated, and distinguished himself in military service. In B.C. 30 Octavianus (Augustus) assumed him as his colleague in the consulship, and he was afterwards governor of Asia or Syria.—Cicero had also a daughter, Tullia, who to his great grief died in 45 B.C.—Cicero's younger brother, QUINTUS, was a man of some note both as a public character and as a writer. He was married to a sister of Atticus, and was put to death at the same time as the orator.

**Cicinde'la**, a genus of insects to which *C. campestris*, the tiger-beetle, one of the most common of American species, belongs.

**Cico'nia**, the genus of birds to which the stork belongs.

**Cicu'ta**, a genus of umbelliferous plants, including *C. virōsa*, water-hemlock or cowbane. See *Hemlock*.

**Cid**, an epithet (from the Ar. *seid*, a lord, a chief, a commander) applied to Ruy or Roderigo Diaz, Count of Bivar (born 1026, died 1099), the national hero of Spain. He signalized himself by his exploits in the reigns of Ferdinand, Sancho, and Alphonso VI. of Leon and Castile; but the facts of his career have been so mixed with glorifying myths that it is scarcely possible to separate them. His life, however, appears to have been entirely spent in fierce warfare with the Moors, then masters of a great part of Spain. His exploits are set forth in a special chronicle, and in a Castilian poem, probably composed about the end of the 12th century. The story of his love for Ximena is the subject of *Le Cid* of Corneille. Whatever chronicles and songs have conveyed to us of the history of the Cid is collected in Southey's *Chronicle of the Cid*.

**Ci'der**, a fermented liquor made from the expressed juice of apples. The apples are ground and crushed until they are reduced to a pulp, the juice is allowed to run into casks, where it is freely exposed to the air until fermentation takes place, when a clear liquor of a pale-brown or amber colour is the result. Worcester, Hereford, and Devon are the great cider-producing counties of England. In France, Germany, and other countries, and particularly in North America, it is also largely made. It contains from 4 or 5 to 10 per cent of alcohol, and is intoxicating if drunk in quantities.

**Cienfuegos** (thē-en-fō-ā'gōs), a seaport of Cuba, on the south coast of the island, with a safe and capacious harbour on the bay of Jagua, 130 miles S.E. of Havana, with which (and other towns) it is connected by railway. It is among the finest towns of the island, and exports sugar, wax, timber, &c., to the value of over £1,000,000 annually. Pop. about 16,000.

**Cieza** (thē-ā'thā), a town, Spain, in the province and 24 miles N.W. of Murcia, on an eminence near the right bank of the Segura. Pop. 10,910.

**Cigar** (si-gär'), a small roll of manufactured tobacco leaves carefully made up, and intended to be smoked by lighting at one end

and drawing the smoke through it. The choicest cigars are those made in and imported from Havana. British cigars are largely made in imitation of the foreign brands, but they have never equalled the latter in quality. Good cigars are also made in the United States and elsewhere. Medicated cigars, or cigars made of some substance having remedial properties, are often used for certain complaints, as stramonium cigars for asthma. *Cheroots* are peculiarly-shaped cigars much thicker at one end than the other, and are largely imported from Manilla.

**Cigarette** (sig-a-ret'), a sort of small cigar made by rolling fine-cut tobacco in thin paper specially prepared for the purpose.

**Cignani** (chē-nyä'nē), CARLO, Italian painter, born at Bologna in 1628, died 1719, the last great painter of the Bolognese school. His finest paintings are frescoes in the saloon of the Farnese Palace, Bologna, and in the cupola of the Church of the Madonna del Fuoco at Forli. His paintings have been engraved by various artists.

**Cigoli** (chē'go-lē), LUDOVICO CARDI DA. See *Cardi*.

**Cil'ia** (L. 'eyelashes'), small, generally microscopic, hair like organs or appendages, averaging  $\frac{1}{30000}$  inch in length, found on the surface of the tissues of most animals, and in some vegetable organisms (as *Volvox*), chiefly on tissues which are in contact with water, or which produce fluid secretions. They are constantly in a state of active movement, and communicate to the fluid with which they are in contact a corresponding motion. This is called *vibratile* or *ciliary motion*. In most of the lower aquatic animals the respiratory function is aided by means of the vibratile cilia; many animalcules move by a similar mechanism: and in the highest classes of animals cilia have a share in the performance of some important functions.

**Cilic'ia**, in ancient geography, the region between Pamphylia and Syria, lying s. of Mount Taurus. Alexander made Cilicia a Macedonian province; it then passed to the Syrians. Under Augustus it became an imperial province. It now forms the Turkish vilayet of Adana.

**Cimabue** (chē-mā-bō'ā), GIOVANNI, Italian painter, born at Florence in 1240, died probably in 1302. Two Greek artists, who were invited to Florence to paint a chapel in the church of Santa Maria Novella, were his first masters. He is considered one of the chief restorers of the art of painting in

Italy, which at that time had degenerated into mechanical conventionalism. His best paintings are in the church of Santa Maria Novello at Florence, and in the Sacro Con-



Cimabue.

vento at Assisi. Among his pupils was Giotto, whom he discovered drawing figures on the smooth surface of a rock while tending his sheep.

**Cimarosa** (chē-mā-rō'sà), DOMENICO, a composer, born at Naples in 1749, -54, or -55, died at Venice 1801. He composed about 120 operas, most of which are comic. His best-known work is *Il Matrimonio Segreto* (the Secret Marriage).

**Cimbri** (sim'bri), a tribe of ancient Europe, the origin of which is involved in obscurity. They were regarded as Germans by the Romans, who gave the name *Chersonesus Cimbrica* to what is now Jutland. Greek writers connected them with the Scythian *Cimmerii* of the Crimea; while modern writers suppose that they were Celtic, and that *Cimbri* is the same as the *Cymri* of Britain. In the 2d century B.C. they made formidable incursions into Gaul and Spain, but were finally routed by the Consul Marius at Vercelli B.C. 101.

**Ci'mex.** See *Bug*.

**Cimme'rians**, an ancient nomadic tribe who occupied the Tauric Chersonese (Crimea) and Asiatic Sarmatia (the country of the lower Volga). They are said, in pre-Homeric times, to have ravaged Asia Minor, and in a second invasion to have penetrated to Æolis and Ionia, and to have held possession of Sardis. A mythical people mentioned in the *Odyssey* as dwelling beyond the ocean-stream in the thickest gloom were also termed *Cimmerii*, a fable which gave rise to the phrase 'Cimmerian darkness.'

**Cimo'lian Earth**, or CIM'OLITE, a species of clay or hydrous silicate of alumina, named from Cimōlos or Argentiera, one of the Cyclades, where it is still to be found. It is of whitish and soft texture, moulders into a fine powder, and effervesces with acids. In classical times it was used as a detergent, as a soap for cleaning delicate fabrics, and by the bath-keepers.

**Cimo'los.** See *Argentiera*.

**Ci'mon**, an ancient Athenian general and statesman, was a son of the great Miltiades. He fought against the Persians in the battle of Salamis (480 B.C.), and shared with Aristides the chief command of the fleet sent to Asia to deliver the Greek colonies from the Persian yoke. The return of Aristides to Athens soon after left Cimon at the head of the whole naval force of Greece. He distinguished himself by his achievements in Thrace, having defeated the Persians by the Strymon, and made himself master of the country. He conquered the pirate-island of Scyros, subdued all the cities on the coast of Asia Minor, pursued the Persian fleet up the Eurymedon, destroyed more than 200 of their ships, and then, having landed, on the same day entirely defeated their army (B.C. 469). He employed the spoil which he had taken in the embellishment of Athens, and in 463 reduced the revolted Thasians; but the popular leaders, beginning to fear his power, charged him on his return with having been corrupted by the King of Macedon. The charge was dropped, but when Cimon's policy of friendship to the Lacedæmonians ended in the latter insulting the troops sent by Athens to their aid, his opponents secured his banishment. He retired into Bœotia, and his request to be allowed to fight with the Athenians against the Lacedæmonians in 457 at Tanagra was refused by the suspicious generals. Eventually Cimon was recalled at the instance of Pericles to conclude a peace with Lacedæmon. He died shortly after, in 449, while besieging Citium in Cyprus.

**Cinchona** (sin-kō'na or sin-chō'na; the name is from the Countess of Chinchon, wife of a viceroy of Peru, a lady who was cured of fever by the bark in 1638), an important genus of trees, type of the order Cinchonaceæ, which consists of gamopetalous, calycifloral dicotyledons, sometimes regarded as a sub-order of Rubiaceæ. They are trees, shrubs, or herbaceous plants, with simple opposite leaves, flowers arranged in

panicles or corymbs; calyx adherent, entire or toothed; corolla regular; stamens attached to corolla; ovary two-celled; fruit inferior, dry or succulent. They are found almost exclusively in the tropics, and many of the species are of great medicinal importance as tonics, febrifuges, emetics, and purgatives. Among their chief products are Peruvian bark, quinine, ipecacuanha, coffee, chay-root, &c. The genus *Cinchona* consists of trees seldom exceeding 40 or 50 ft. in height, with simple, opposite, entire leaves and small flowers, inhabiting chiefly the east side of the Andes of Peru, Bolivia, Ecuador, and Colombia. The valuable Peruvian bark is yielded by various species;



*Cinchona* (*Cinchona succirubra*).

crowns or loxa bark by *C. Condaminea*, gray or huanuco bark by *C. micrantha* and *C. nitida*, red-bark by *C. succirubra*, yellow or calisaya bark by *C. Calisaya*. From the wasteful method of cutting down the trees to get their bark it was believed that there would soon be a dearth of the valuable medicine, and hence cinchona plants were taken from their native regions and plantations formed in various tropical countries, so that Ceylon, India, Java, &c., are now important sources of Peruvian bark. The bark is taken off in strips longitudinally, and is in time renewed by natural growth. See *Bark* (Peruvian), *Quinine*.

**Cinchonine**, a vegetable alkaloid contained in all the varieties of Peruvian bark, but principally in *C. lancifolia*, or pale-bark. Though less bitter than quinine, it may be substituted for it in larger quantities.

**Cincinnati** (sin-sin-à'tē), 'the Queen of the West,' a city of the United States, in Hamilton county, Ohio, on the north bank of the river Ohio. It was first regularly laid out in 1789, and began to flourish after 1794. It stands partly in a valley, partly on hills, and has an area of 24 sq. miles; the central part is very compact, and a great portion of the houses are handsomely built of freestone, blue limestone, or brick. Noteworthy buildings are the Cincinnati College and several other col-

leges, Cincinnati University, the public library, court-house, masonic temple, city-hall, music-hall, art museum, &c. St. Peter's Roman Catholic cathedral is one of the finest buildings in the western states. There are ten parks and numerous cemeteries. Cincinnati is an important manufacturing place, its chief trade being in railway materials and supplies, carriages, furniture, leather, boots and shoes, clothing, candles, soap and oils, liquors, &c. Next to Chicago it is the greatest pork market in the Union. In addition to the fine river, railways and canals stretch from it in every direction, connecting it with every port on the great lakes from Chicago to Niagara, and with Albany, Boston, New York, Philadelphia, &c. Pop. 1890, 296,908.

**Cincinnati, SOCIETY OF THE**, an organization originating among the officers of the American revolutionary army in 1783. On its roll of members are the most distinguished names in American history. It is essentially of an exclusive and aristocratic character, the right of membership being restricted to the eldest male in descent from the original members; or, the direct line becoming extinct, to the eldest male of the next collateral branch. The name is after 'that illustrious Roman,' Lucius Quinctius Cincinnatus. (See following article). The general society is divided into state societies, and these into district societies, which meet annually on July 4th. The general society meets in May, mostly triennially.

**Cinna'tus, LUCIUS QUINCTIUS**, a wealthy patrician in the early days of the Roman Republic, born about 519 B. C. He succeeded Publicola in the consulship, and then retired to cultivate his small estate beyond the Tiber. The messengers of the senate found him at work when they came to summon him to the dictatorship. He rescued the army from its peril, and then returned quietly to his farm. At the age of eighty he was again appointed dictator to oppose the ambitious designs of Spurius Mælius.

**Cinera'ria**, a genus of plants, nat. order Compositæ, chiefly found in South Africa.

**Cin'erary Urns**, urns in which the ashes of the dead were deposited after the body was burned.

**Cinna**, **LUCIUS CORNELIUS**, an eminent Roman, an adherent of Marius, who, obtaining the consulship B.C. 87, along with Cneius Octavius, impeached Sulla and endeavoured

to secure the recall of Marius. Being driven from the city by Octavius, he raised the Italian cities, and invested Rome while Marius blockaded it from the sea. On its capture the friends of Sulla were massacred, and Cinna and Marius made themselves consuls (B.C. 86); but after the death of Marius the army refused to follow Cinna against Sulla, and put him to death in B.C. 84.

**Cin'nabar**, red sulphide of mercury, the principal ore from which that metal is obtained, occurring abundantly in Spain, California, China, &c. It is of a cochineal-red colour, and is used as a pigment under the name of vermilion. See *Mercury* and *Vermilion*.

**Cinnamo'mum**, a genus of plants, nat. order Lauraceæ, natives of tropical Asia and the Polynesian Islands. All the species possess an aromatic volatile oil, and one of them yields true cinnamon, while others yield cassia.

**Cin'namon**, the bark of the under branches of a species of laurel (*Cinnamōmum zeylanicum*—see *Cinnamomum*), which is chiefly found in Ceylon, but grows also in Malabar and other parts of the East Indies. The tree attains the height of 20 or 30 feet, has oval leaves, pale-yellow flowers, and acorn-shaped fruit. The Ceylonese bark their trees in April and November, the bark curling up into rolls or quills in the process of drying; the smaller quills being introduced into the larger ones. These are then assorted



Cinnamon (*Cinnamōmum zeylanicum*).

according to quality by tasters, and made up into bundles. An oil of cinnamon is prepared in Ceylon, but the oil of cassia is generally substituted for it; indeed, the cassia bark is often substituted for cinnamon, to which it has some resemblance, although in its qualities it is much weaker. The leaves, the fruit, and the root of the cinnamon plant all yield oil of considerable value; that from the fruit, being highly fragrant and of thick consistence, was formerly made into candles for the sole use of the King of Ceylon.

**Cinnamon-stone**, a variety of garnet, of a cinnamon, hyacinth-red, yellowish-brown,

or honey-yellow colour, found in Scotland, Ireland, Ceylon, &c. The finer kinds are used as gems.

**Cino da Pistoia**, an Italian juriconsult and poet, born in 1270 at Pistoia. He was the friend of Petrarch and of Dante, and ranks amongst the best of the early Italian poets. His poems were first published at Rome in 1558.

**Cinq-Mars** (sank-märs), HENRI COIFFIER DE RUZÉ, MARQUIS DE, favourite of Louis XIII., born in 1620, and introduced at court by Cardinal Richelieu. The king made him master of the robes and grand equerry of France when only in his nineteenth year, and he soon aspired, not only to a share in the management of public affairs, but even to the hand of the beautiful Maria di Gonzaga, princess of Mantua. Thwarted, however, by the cardinal, Cinq-Mars concocted a plot for the overthrow of Richelieu, and entered into treaty with Spain. To propitiate Richelieu the king was compelled to sacrifice his favourite, who was arrested at Narbonne and beheaded with his friend the young councillor De Thou at Lyons in 1642.

**Cinque-cento** (chēn'kwā-chen-tō; It., lit. 500, but used as a contraction for 1500, the century in which the revival took place), a term employed in reference to the decorative art and architecture belonging to that attempt at purification of style and reversion to classical forms introduced soon after the beginning of the 16th century in Italy. The term is often loosely applied to ornament of the 16th century in general, properly included in the term *Renaissance*.

**Cinque-foil** (singk'foil), in architecture, an ornament in the Gothic style, consisting of five foliated divisions, often seen in circular windows.

**Cinque Ports** (singk), originally the five English Channel ports of Hastings, Romney, Hythe, Dover, and Sandwich, on the S.E. coast of England, to which were added subsequently the towns of Winchelsea, Rye, and Seaford. They were granted special privileges by the later Saxon and earlier Norman kings, on condition of providing a certain number of ships during war, there being no permanent English navy previous to the reign of Henry VII. Each port returned two members to parliament, but after the Reform Act of 1832 Hastings, Dover, and Sandwich alone retained this privilege, Rye and Hythe returning one each, and the remaining towns none. Sandwich was afterwards disfranchised for corruption, and by the

act of 1885 Hastings and Dover were each deprived of a member, and Rye ceased to be a borough. They are, collectively, in the jurisdiction of a lord warden, who receives £3000 a year for his sinecure.

**Cin'tra**, a town, Portugal, 15 miles W.N.W. Lisbon, finely situated on the slope of the Sierra de Cintra, and much resorted to by the wealthier inhabitants of Lisbon. The kings of Portugal have a palace with fine gardens at Cintra. The town is celebrated for the convention entered into there in 1808, by which the French, after their defeat at Vimeira, were conveyed to France. Pop. 4751.

**Cione** (chi-ō'nā), ANDREA DI. See *Oragna*.

**Ciotat** (si-ō-tā), LA, a seaport, France, on the Mediterranean, 15 miles S.E. of Marseilles, surrounded by an old rampart, and having well-built houses and spacious streets. Ship-building is carried on and an extensive coasting trade. Pop. 8877.

**Ciphers**, signs used to represent numbers, whether borrowed signs, as letters, with which the Greeks designated their numbers, or peculiar characters, as the modern or Arabic ones. The ciphers, such as they are at present, 1, 2, 3, 4, 5, 6, 7, 8, 9, 0, did not come into common European use until the 11th century. For *cipher* as applied to methods of secret writing see *Cryptography*.

**Cippus**, in Roman antiquities, a low column generally rectangular and sculptured, and often bearing an inscription. They served as sepulchral monuments, as milestones and boundaries, and in some cases to receive the inscribed decrees of the senate.

**Cipriani** (chē-prē-ā'nē), GIAMBATTISTA, Italian painter and engraver, born at Pistoia in 1732; came to England in 1754; died at London in 1785. He was one of the first fellows of the Royal Academy, the diploma of which he designed. He furnished Bartolozzi with the subjects of some of his finest engravings.

**Circars**, THE FIVE NORTHERN, an ancient division of the Madras presidency, on the east coast of Hindustan, the circars being Chicacole, Rajahmundry, Ellore, Condapilly, and Guntoor. The districts that now correspond most nearly with them are Ganjam, Vizagapatam, Godavari, and part of Krishna.

**Circas'sia**, or TCHERKESSIA, a mountainous region in the south-east of European Russia, lying chiefly on the north slope of the Caucasus, partly also on the south, and bounded on the west by the Black Sea, and

now forming part of the Lieutenancy of the Caucasus. The mountains, of which the culminating heights are those of Mount Elbruz, are intersected everywhere with steep ravines and clothed with thick forests, and the territory is principally drained by the Kuban and its tributaries. Its climate is temperate, its inhabitants healthy and long-lived. The people call themselves *A-dighé*, the name *Tcherkess* (robbers) being of Tartar origin. They are divided into several tribes speaking widely-different dialects. While they retained their independence their government was of a patriarchal character, but every free Circassian had the right of expressing his opinion in the assemblies. They possessed none but traditional annals and laws. Polygamy was permissible in theory, but not



Circassians.—From *Hommaire de Heli*.

common. The duties of hospitality and vengeance were alike binding, and a Spartan morality existed in the matter of theft. Their religion, which is nominally Moslem, is in many cases a jumble of Christian, Jewish, and heathen traditions and ceremonies. As a race the Circassians are comely, the men being prized by the Russians as warriors, and the women by the Turks as mistresses, a position generally desired by the women themselves. The early history of Circassia is obscure. Between the 10th and 13th centuries it formed a portion of the empire of Georgia, but in 1424 the Circassians were an independent people, and at war with the Tartars of the Crimea, &c., to whose khans, however, some were occasionally tributary. In 1705 the Tartars were defeated in a decisive battle, but shortly after the territorial

encroachments of the Russians on the Caucasian regions began, and in 1829 the country was formally annexed by them. A heroic resistance was made by the Circassians under their leader Schamyl, and on being reduced to submission numbers of the inhabitants emigrated to the Turkish provinces. In the north and east, however, tribes of the Circassian stock remain. The Circassians, properly so called, have been estimated to number from 500,000 to 600,000.

**Circe** (*sér-sē*), a fabled sorceress of Greek mythology, who lived in the island of *Ææa*, represented by Homer as having converted the companions of Ulysses into swine after causing them to partake of an enchanted beverage. Ulysses under the guidance of Hermes compelled her to restore his companions, and

afterwards had two sons by her.

**Circensian Games.** See *Circus*.

**Cir cinate**, in botany, said of leaves or fronds, as those of ferns, that are rolled up like a watch-spring before expanding.

**Circle** is a plane figure contained by one line, which is called the *circumference*, and is such that all straight lines drawn from a certain point (the *centre*) within the figure to the circumference are equal to one another. The properties of the circle are investigated in books on geometry and trigonometry. Properly the curve belongs to the class of *conic sections*, and is a curve of the *second order*. A *great circle* of a sphere is one that has its centre coinciding with that of the sphere. The celebrated problem of 'squaring the circle,' is to find a square whose area shall be equal to the area of any



given circle. It is not possible to do so. All that can be done is to express *approximately* the ratio of the length of the circumference of the circle to the diameter, and to deduce the area of the figure from this approximation. If the diameter be called unity, the length of the circumference of the circle is 3.1415926535...; and the area of the circle is found by multiplying this number by the square of the radius. Thus the area of a circle of 2 feet radius is  $3.14159 \times 4$ , or 12.56636 square feet approximately. For trigonometrical calculations the circumference of the circle is divided into 360 equal parts called degrees, each degree is divided into 60 minutes, and each minute into 60 seconds.

**Circle, MURAL.** See *Mural Circle*.

**Circleville**, a town of Ohio, U.S., on the Scioto river, 100 miles N.E. from Cincinnati. Pop. 1890, 6556.

**Circuit** (sér'kit), a division of a country for judicial purposes, to some town or towns in which judges come at regular periods to administer justice.

**Circuit Courts**, a term applied distinctively to a class of the Federal courts of the United States, of which terms are held in two or more places successively, in the various circuits into which the country is divided for the purpose.

**Circular Notes**, notes or letters of credit furnished by bankers to persons about to travel abroad. Along with the notes the traveller receives a 'letter of indication' bearing the names of certain foreign bankers who will cash such notes on presentation, in which letter the traveller must write his name. On presentation the foreign banker can demand to see the letter of indication, and by causing the presenter to write his name can compare the signature thus made with that in the letter, and so far satisfy himself as to the identity of the person presenting the note.

**Circulating Medium.** See *Currency*.

**Circulation**, in an organism, the flowing of sap or blood through the veins or channels, by means of which the perpetual and simultaneous movements of composition and decomposition manifested in organic life are carried on. Although Galen, who had observed the opposite directions of the blood in the arteries and veins, may be said to have been upon the very point of discovering the circulation, the discovery was reserved for William Harvey, who in 1628 pointed out the continuity of the connections

between the heart, arteries, and veins, the reverse directions taken by the blood in the different vessels, the arrangements of valves in the heart and veins so that the blood could flow only in one direction, and the necessity of the return of a large proportion of blood to the heart to maintain the supply. In 1661 Malpighi exhibited microscopically the circulation in the web of a frog's foot, and showed that the blood passed from arteries to veins by capillaries or intermediate vessels. This finally established the theory with regard to animals, but the movements of sap in vegetables were only traced with difficulty and after numerous experiments. Many physiologists indeed are still disposed to refuse the term 'circulation' to this portion of the economy of plants; but though sap, unlike the blood, does not exhibit movements in determinate vessels to and from a common centre, a definite course is observable. In the stem of a dicotyledonous tree, for example, the sap describes a sort of circle, passing upwards from the roots through the newer woody tissue to the leaves, where it is elaborated under the action of air and light; and thence descending through the bark towards the root, where what remains of it is either excreted or mixed with the new fluid, entering from the soil for a new period of circulation. In infusorial animalcules the movement of the fluids of the body is maintained by that of the animal itself and by the disturbing influence of nutritive absorption. In the Cœlenterata (zoophytes, &c.) the movement receives aid besides from the action of cilia on the inner walls of the body. The Annelids, as the earth-worm, possess contractile vessels traversing the length of the body. The Insects, Crustaceans, Myriapods, and Spiders have a dorsal tube, a portion of which may be specially developed as a heart. The blood is driven to the tissues, in some cases along arterial trunks, being distributed not in special vessels, but simply through the interstices of the tissues. From the tissues it is conveyed, it may be by special venous trunks to a venous sinus which surrounds the heart and opens into it by valvular apertures. The Mollusca have the heart provided with an auricle and a ventricle, as in the snail and whelk; two auricles, one on either side of the ventricle, as in the fresh-water mussel; or two auricles and two ventricles, as in the ark-shells. Among the ascidians, which stand low in that division of animals to which the molluscs belong, the

remarkable phenomenon is encountered of an alternating current, which is rhythmically propelled for equal periods in opposite directions. All vertebrated animals (except *Amphioxus*) have a heart, which in most fishes consists of an auricle and ventricle, but in the mud-fishes (*Lepidosiren*) there are two auricles and one ventricle; and this trilocular heart is found in the amphibians, and in most reptiles except the crocodiles, which, like birds and mammals, have a four-chambered organ consisting of two auricles and two ventricles. In these two last-named classes the venous and arterial blood are kept apart; in the trilocular hearts the two currents are mixed in the ventricle. For circulation in man and the higher animals see *Heart*.

**Circumcision**, a rite common amongst the Semites, though by no means peculiar to them, and possibly derived by them from the Egyptians or from some non-Semitic source. At any rate the antiquity of its institution in Egypt is fully established by the monuments, which make it evident that it was practised at a period very much earlier than the Exodus. It was, however, a primitive Arab custom, and its practise amongst the Jews may with equal probability be assigned to an Arab source. Whatever its origin, the rite is confined to no single race. It was practised by the Aztecs and other peoples of Central America, and is still to be found amongst tribes on the Amazon, amongst the Australian tribes, the Papuans, the inhabitants of New Caledonia, and those of the New Hebrides. In Africa it is common amongst the Kaffirs and other tribes widely removed from Semitic influence. It is practised also by the Abyssinian Christians, and although not enjoined in the Koran has been adopted by the Mahometans on the example of Mahomet himself. It was possibly in its origin a sacrifice to the deity presiding over generation, though in certain nations the rite has acquired a new symbolic significance according to the stage of their spiritual development.

*Circumcision* is also the name of a feast, celebrated on the 1st of January, in commemoration of the circumcision of our Saviour. It was anciently kept as a fast, in opposition to the pagan feast on that day in honour of Janus.

**Circumnavigators**, a term usually applied to the early navigators who sailed round the globe. Magellan, a Portuguese in the service of Spain, headed the first

expedition which succeeded in circumnavigating the globe, though he did not live to complete the voyage. He sailed with five ships from San Lucar Sept. 20, 1519, passed the straits named after him in Nov. 1520, and was killed in the Philippine Islands in April, 1521, Juan Sebastian del Cano continuing the voyage and reaching San Lucar with the only remaining ship in Sept. 1522. The principal early navigators, after Magellan, who succeeded in making the voyage round the globe were Grijalva and Alvaradi (Spaniards), 1537; Mendana (Spanish), 1567; Drake (English), 1577-80; Cavendish, 1586-88; Le Maire (Dutch), 1615-17; Quiros (Spanish), 1625; Tasman (Dutch), 1642; Cowley, 1683; Dampier, 1689; Cooke, 1708; Clipperton, 1719; Roggewein (Dutch), 1721-23; Anson, 1740-44; Byron, 1764-66; Wallis, 1766-68; Carteret, 1766-69; Bougainville, 1766-69; Cook, 1768-71; and Portlocke, 1788.

**Circumnutation** (lit. 'a nodding round about'), a name given by Darwin to the continuous motion of every growing part of every plant, in which it describes irregular elliptical or oval figures. The apex of the stem, for instance, after pointing in one direction, moves round till it points in the opposite direction, and so on continuously.

**Circumstantial Evidence.** See *Evidence*.

**Circumvallation**, or LINE OF CIRCUMVALLATION, in military affairs, a line of field-works consisting of a rampart or parapet with a trench surrounding a besieged place, or the camp of a besieging army.

**Circus**, among the Romans, a nearly oblong building without a roof, in which public chariot-races and exhibitions of pugilism and wrestling, &c., took place. It was rectangular, except that one short side formed a half-circle; and on both sides, and on the semicircular end, were the seats of the spectators, rising gradually one above another, like steps. On the outside the circus was surrounded with colonnades, galleries, shops, and public places. The largest of these buildings in Rome was the *Circus Maximus*, capable, according to Pliny, of containing 260,000, and according to Aurelius Victor, 385,000 spectators. At present, however, but few vestiges of it remain, and the circus of Caracalla is in the best preservation. The games celebrated in these structures were known collectively by the name of *ludi circenses*, circensian games, or games of the circus, which under the emperors attained the

greatest magnificence. The principal games of the circus were the *ludi Romani* or *magni* (Roman or Great Games), which were celebrated from the 4th to the 14th of September, in honour of the *great gods*, so called. The passion of the common or poorer class of people for these shows appears from the cry with which they addressed their rulers—*panem et circenses* (bread and the games!). The festival was opened by a splendid procession, or *pompa*, in which the magistrates, senate, priests, augurs, vestal virgins, and athletes, took part, carrying with them the images of the great gods, the Sibylline books, and sometimes the spoils of war. On reaching the circus the procession went round once in a circle, the sacrifices were performed, the spectators took their places, and the games commenced. These were: 1. Races with horses and chariots, in which men of the highest rank engaged. 2. The gymnastic contests. 3. The Trojan games, prize contests on horseback, revived by Julius Cæsar. 4. The combats with wild beasts, in which beasts fought with beasts or with men (criminals or volunteers). 5. Representations of naval engagements (*naumachie*), for which purpose the circus could be laid under water. The expense of these games was often immense. Pompey, in his second consulship, brought forward 500 lions at one combat of wild beasts, which, with eighteen elephants, were slain in five days.

The *modern circus* is a place where horses are trained to perform antics, and where exhibitions of acrobats and various pageant-tries, including a large amount of buffoonery, are presented.

**Cirencester**, or CICESTER (pron. colloquially *sis'e-tér* or *sis'es-tér*), a town of England, county and 18 miles S.E. of Gloucester; founded by the ancient Britons, and subsequently, under the name of Corinium, a Roman station. It has a well-known Royal Agricultural College. The trade is chiefly agricultural. It was a parliamentary borough till 1885, and now gives name to a parl. div. of the county. Pop. 1891, 7441.

**Cirrho'sis**, a disease characterized by growth of fibrous tissue which gradually encroaches on and by compression destroys the true structure of the organ attacked. It is very frequent in the liver as a consequence of spirit-drinking; and hence the term 'drunkard's liver.'

**Cirripedes** (*sir'i-pēdz*), CIRRIPE'DIA, or CIRRHOP'ODA, a class of marine invertebrate

animals, having a soft body provided with very long articulated tendril-like limbs (*cirri*), which are protruded and rapidly withdrawn within the multivalve shell. They are crustaceans which have undergone retrograde metamorphosis, being free-swimming in the larva form, but becoming after a time attached by the head. When adult they are affixed to some substance, either set directly upon it, as in the genus *Balanus*; or placed on a foot-stalk, as the barnacle; or sunk into the supporting substance, as the whale-barnacle. See *Balanus*, *Barnacle*.

**Cirrus** (in plural CIRRI), the tendril of a plant by means of which it climbs, usually a modified leaf or the prolongation of a midrib.

**Cirrus**. See *Cloud*.

**Cirta**, the capital of the ancient Massylii in Numidia. After the defeat of Jugurtha it passed into the hands of the Romans, and was restored by Constantine, who gave it his own name. See *Constantine*.

**Cisal'pine Republic**, a state set up in 1797 by Napoleon I. in North Italy, recognized by Germany as an independent power at the Peace of Campo-Formio. It comprised Austrian Lombardy, together with the Mantuan and the Venetian provinces, Bergamo, Brescia, Crema, Verona, and Rovigo, the duchy of Modena, the principality of Massa and Carrara, Bologna, Ferrara, and Romagna, and latterly its area was 16,337 square miles; its pop. 3,500,000. The legislative body held its sessions in Milan. On January 25, 1802, it received the name of the *Italian Republic*; from 1805 to 1814 it formed part of the Kingdom of Italy; and it was given to Austria by the Congress of Vienna in 1815 as the Lombardo-Venetian Kingdom.

**Cisleitha'nia**, CISLEITHAN PROVINCES, Austria proper or Austria west of the river Leitha, which partly forms the boundary between it and Hungary. See *Austria*.

**Cis'padane Republic**, a state on the south of the Po set up by Napoleon I., but speedily united with the Transpadane Republic to form the Cisalpine Republic.

**Cisrhe'nish Republic**, several towns on the Rhine, particularly Cologne, Aix-la-Chapelle, and Bonn, which constituted themselves a brief-lived republic under French protection in Sept. 1797.

**Cist**, a place of interment of an early or prehistoric period, consisting of a rectangular stone chest or inclosure formed of rows of stones set upright, and covered by similar flat

stones. Such cists are found in barrows or mounds, inclosing bones. In rocky districts cists were sometimes hewn in the rock itself.



Cist, found near Driffield, Yorkshire.

**Cista'cææ**, a natural order of polypetalous exogens, consisting of low shrubby plants or herbs with entire leaves and crumpled, generally ephemeral, showy flowers. Some exude a balsamic resin, such as ladanum from a Levant species of *Cistus*. Four species of the genus *Helianthemum* are found in Britain, and are popularly known as the 'rock-rose.' See *Cistus*.

**Cister'cians**, a religious order named from its original convent, Cîteaux (*Cistercium*), not far from Dijon, in Eastern France,



Cistercian.

where the society was formed in 1098 by Robert, abbot of Molesme, under the strictest observance of the rule of St. Benedict. The Cistercians led a severely ascetic and contemplative life, and having freed themselves from episcopal supervision, formed a kind of spiritual republic under a high council of twenty-five members, with the abbot of Cîteaux as president. Next to Cîteaux the four chief monasteries were La Ferté, Pontigny, Clairvaux (founded by the celebrated St. Bernard in 1115), and Morimond. In France they called themselves *Bernardines* in honour of St. Bernard. Among the fraternities emanating from them the most

remarkable were the Barefooted monks, or Feuillants, and the nuns of Port Royal, in France; the Recollets, or reformed Cistercians; and the monks of La Trappe. There were a hundred Cistercian houses in England at the dissolution of monasteries. The general fate of religious orders during the French revolution reduced the Cistercians to a few convents in Spain, Poland, Austria, &c. There are still two or three houses in the British Isles. The Cistercians wear white robes with black scapularies.

**Cistus**, the rock-rose, a genus of plants of many species, order Cistacææ, natives of Europe, or of the countries bordering the Mediterranean. Some of them are beautiful evergreen flowering shrubs, ornamental in gardens or shrubberies. Gum ladanum is obtained from *C. creticus* and *C. ladaniferus*.

**Cit'adel**, a strong fortress in or near a city intended to keep the inhabitants in subjection, or to form a final point of defence in case of an attack of enemies.

**Cita'tion**, a summons or official notice given to a person to appear in a court as a party or witness in a cause.

**Cîteaux** (sē-tō), a village of Eastern France, dep. Côte-d'Or. See *Cistercians*.

**Cithæ'ron**, the modern ELATE'A, a mountain of Greece, which, stretching N.W., separates Bœotia from Megaris and Attica. Its loftiest summit is 4620 feet in height. On its northern slope stood the city of Plataea.

**Cith'ern**, or CITH'ERN (Latin *cithara*, Greek *kithara*), an old instrument of the guitar kind, strung with wire instead of gut. Its eight strings were tuned to 4 notes, G, B, D, and E. It was frequently to be found in barbers' shops for the amusement of the waiting customers.



Cittern, in South Kensington Museum.

**Cities of Refuge**, six out of the forty-eight cities given to the tribe of Levi in the division of Canaan, set apart by the law of Moses as places of refuge for the manslayer or accidental homicide. Their names were Kedesh, Shechem, and Hebron on the west side of Jordan; and Bezer, Ramoth-Gilead, and Golan on the east.

**Cities of the Plain.** See *Sodom and Gomorrah*.

**Cit'ric Acid** ( $C_6H_8O_7$ ), the acid of lemons, limes, and other fruits. It is generally prepared from lemon-juice, and when pure is white, inodorous, and extremely sharp in its taste. In combination with metals it forms crystalline salts known as citrates. The acid is used as a discharge in calico-printing and as a substitute for lemon in making beverages.

**Cit'ron**, *Citrus mēdica*, a small evergreen shrub yielding a fruit which is candied with sugar. The rind is considered superior to the pulp; it is imported in a preserved state, and is used in confectionery. The juice is less acid than that of the lemon. See *Citrus*.

**Citronella Oil**, an oil obtained from a kind of grass (*Andropogon nardus*), cultivated at Singapore and in Ceylon. It is used for scenting soap.

**Citru'l'us**. See *Colocynth*.

**Cit'rus**, an important genus of trees, nat. order Aurantiaceæ, or that of the orange, characterized by simple ovate acuminate leaves or leaflets united by a distinct joint to the leaf-like stalk; by having the stamens united by their filaments into several irregular bundles, and by yielding a pulpy fruit with a spongy rind.—*Citrus mēdica* is the citron. Other species are the lemon (*Citrus limōnum*), the sweet orange (*Citrus aurantium*), the bitter orange (*Citrus vulgāris*), the shaddock (*Citrus decumāna*), and the forbidden fruit (*Citrus paradīsi*), sometimes used as an ornamental addition to dessert. The genus *Citrus* furnishes the essential oils of orange and lemon peels, of orange flowers, of citron peel, of bergamot, and oil of orange leaves—all much esteemed in perfumery. See *Lemon*, *Orange*, &c.

**Cittadella** (chēt-tā'-), an old town of North Italy, province of Padua, surrounded by walls. Pop. 3881.

**Città-di-Castello**, a town, Italy, province Perugia, on the Tiber, the seat of a bishop, with a cathedral containing valuable paintings. Pop. 5433.

**Città-Vecchia** (chēt-tā-vek'i-ā, 'old city'), a fortified town of Malta, near the centre and almost on the highest point of the island, 7 miles w.s.w. Valetta. The rise of the latter town has almost ruined it, and its magnificent houses and palaces are almost deserted. It has a large cathedral and interesting catacombs. The ancient palace of the grandmasters of the Order of Malta also remains. Pop. 4700.

**Cit'tern**. See *Cithern*.

**City** (Latin, *civitas*), in a general sense, a town holding, from extent of population, favourable situation, or other causes, a leading place in the community in which it is situated. Popularly, also, it is used, both in Britain and France, to designate the old and central nucleus as distinguished from the suburban growths of large towns. The ecclesiastical sense of the term city is a town which is, or has been, the see of a bishop. This seems to be the historical use of the term in England, and still possesses some authority there, but to a considerable extent it has been superseded by the wider one. In America the application of the term is dependent upon the nature and extent of the municipal privileges possessed by corporations, and a town is raised to the dignity of a city by special charter. Generally the term implies the existence of a mayor at the head of the municipality.

**Ciudad** (thi-ö-dād'), the Spanish word for city, appearing in many names of Spanish places.

**Ciudad Bolivar** (thi-ö-dād' bo-lē'vär). See *Angostura*.

**Ciudadela** (thi-ö-dā-dā'là), a walled city and seaport, Spain, on the west side of the island of Minorca. Chief industries: weaving woollen fabrics, expressing oil and wine, and husbandry. Pop. 7335.

**Ciudad-Real** (thi-ö-dād-rā-äl', 'royal town'), a town of Spain, capital of the province of same name, on a low plain near the Guadiana, 100 miles south of Madrid. The principal edifice is the Church of Santa Maria, a magnificent structure though consisting only of a single nave. Pop. 13,801.—The province occupies the south extremity of New Castile, between the parallel ranges of the Sierra Toledo and Sierra Morena; area, 7840 square miles. Pop. 280,075.

**Ciudad-Rodrigo** (thi-ö-dād-rod-rē'gō, 'Roderick-town'), a fortress in Spain, in Leon, on the river Aguada, was a place of considerable importance in early Spanish history as a fortress on the Portuguese frontier, and was of some importance in the Peninsular war, being taken by storm by the British under Wellington, after a siege of eleven days. The Cortes gave Wellington the title of Duke of Ciudad-Rodrigo.

**Cive**. See *Chive*.

**Civ'et** (*Viverra*), a genus of carnivorous mammals found in N. Africa, and in Asia from Arabia to Malabar and Java, and distinguished by having a secretory apparatus in which collects the odoriferous fatty sub-

stance known as *civet*. The animal, which in form is intermediate between the weasel and the fox, and from 2 to 3 feet long by 10 inches high, is of a cinereous colour, tinged with yellow and marked by dusky spots disposed in rows. They are nocturnal, and prey upon birds and small animals, and may be considered as forming the transition from the musteline or marten kind to the feline race. The genus has been divided into two sub-genera—the true *civets*, having the pouch large and well marked; and the *genets*, in which there is a simple depression instead of a pouch. Two species of the first and eight of the second are at present known, the chief scent-yielding species being the common civet (*Viverra civetta*) of N. Africa and the zibeth (*V. zibetha*) of Asia. The pouch is situated between the anus and the genitals, and the odorous matter obtained from it is, when good, of a clear yellowish or brown colour. The smell is powerful and very offensive, but when diluted with oil or other materials is an agreeable perfume. The American variety of the civet (civet cat) is easily tamed.

**Civic Crown**, among the Romans, the highest military reward, assigned to him who had preserved the life of a citizen. It bore the inscription '*Ob civem servatum*,' that is, 'for saving a citizen,' and was made of oak leaves. The person who received the crown wore it in the theatre, and sat next the senators, and when he came in all the assembly rose up as a mark of respect.

**Cividale** (chē-vē-dā'lā), a walled town, Italy, Venetia, 8 miles E.N.E. of Udine. It has a large cathedral dating from the 8th century. Pop. 3791.

**Civil Death.** See *Death, Civil*.

**Civiliza'tion**, the sum at any given time of the attainments and tendencies by which the human race or any section of it is removed from the savage state. The history of progress in civilization is usually presented from one of two points of view—the first conceiving the race as starting from a high civilization, to which in point of intellectual and moral power it has yet to return; the second viewing the civilization of any period as the result of a constant and increasingly-successful stream of effort upwards from an origin comparable with the condition of the lower animals. The latter is the prevailing scientific theory, which finds the secret of progress in the interaction of function and environment. According to it primitive man, at first feeding on wild fruits and

berries, and sheltering himself under overhanging rocks or caves, entered upon the stone age, in which, as the contemporary of the mammoth and cave-bear, he made himself sharp-edged tools by chipping the flakes of flint found in the drift under gravel and clay. In the newer stone age he learned the art of polishing these rough implements, with which he cut down trees to make canoes, killed wild animals for food, and broke their bones for marrow, or shaped them into weapons. Fire he turned to account to hollow out trees, to cook his food, to fashion clay ware. Artificial means of shelter were constructed by piling rude huts of stones, by digging holes in the ground, or by driving piles into the beds of lakes and raising dwellings on them. The artistic instincts found expression in drawings of animals scratched upon bone or slate. The discovery of metals constituted a great step in advance. Gold and copper came early into use, and bronze was soon discovered, though a long time passed before iron was smelted and substituted for bronze where hardness was required. Gradually the roving savage became a nomadic shepherd and herdsman, or a tiller of the soil, according to his environment. The practice of barter was in part superseded by the beginnings of some sort of currency. Gesture language gave place in part to an enlarged vocabulary, and picture-writing to the use of phonetic signs. In the meantime man had begun to question himself and the world on profounder issues, entering upon the myth-making age, in which was projected outwards on the chief phenomena of nature some shadow of his own personality. The worship of the sun, moon, and stars, a faith in a future life, the worship of dead ancestors, fetishes, animals, &c., the belief in magic and witchcraft, all sprang into being. Prayer came spontaneously to him; the idea of propitiation by sacrifice would arise from his dealings with his fellows and his foes; the sacred books began to shape themselves. Tribal and national relations, arising from ties of family and exigences of defence, were cemented by unity of faith, and the higher social unit began to perfect itself under the rule of the patriarch, the bravest warrior, &c. With varying needs, arising from diversity of environment, distinctions of nationality became more and more emphatic, and the history of civilization becomes the history of the nations viewed from the philosophic standpoint.

**Civil Law** (*jus civile*), among the Romans the term nearly corresponding to what in modern times is implied by the phrase *positive law*, that is, the rules of right established by any government. They contradistinguished it from natural law (*jus naturale*), by which they meant a certain natural order followed by all living beings: also from the general laws of mankind established by the agreement of all nations and governments (*jus gentium*). With the growth and multiplication of the edicts issued by the prætors (in whose hands was the supreme administration of justice) for the modification and extension of the positive enactments a further distinction became necessary, the whole body of this prætorian law being known by the name of *jus honorarium* as opposed to the strict formal law (*jus civile*). The latter, however, included both the private law (*jus privatum*), which relates to the various legal relations of the different members of the state — the citizens — and the public law (*jus publicum*), that is, the rules respecting the limits, rights, obligations, &c., of the public authorities. The final digest of Roman law was made in the 6th century A.D. under the Emperor Justinian, but at first was only admitted as formally binding in a small part of Italy. After the 11th century, in Upper Italy, particularly in the school of Bologna, the body of the Roman law, put together by Justinian, was formed by degrees into a system applicable to the wants of all nations; and on this model the ecclesiastical and Papal decrees were arranged, and to a considerable degree the native laws of the new Teutonic states. From all these the Roman law was distinguished under the name of *civil law*. In this sense, therefore, *civil law* means *ancient Roman law*; and it is contradistinguished from *canon law* and *feudal law*, though the feudal codes of the Lombards have been received into the *corpus juris civilis*, or body of civil law. As the Roman code exerted the greatest influence on the private law of modern Europe, the expression *civil law* is also used to embrace all the rules relating to the private rights of citizens. Under the term *civil law*, therefore, in America and Europe, is to be understood not only the Roman law, but also the modern private law of the various countries; for example, in Germany, *Das gemeine Deutsche Privatrecht*; in France the *Code civil des Français* or *Code Napoléon*. In this sense it is chiefly opposed to *criminal law*, particularly in reference to the ad-

ministration of justice, which is to be divided into *civil justice* and *criminal justice*.

**Civil List**, in Britain, formerly the whole expenses of the government, with the exception of those of the army, navy, and other military departments. It is now limited to the expenses proper to the maintenance of the household of the sovereign. It was once a principle in England, as in other Teutonic nations, that the monarch was to pay all the expenses of government, even including those of the army, from the possessions of the crown, and until the Restoration the whole expenses of the government continued to be defrayed out of the royal revenue. In the reign of William, the Commons adopted the principle of separating the regular and domestic expenses of the king from the public expenditure, and establishing a systematic and periodical control over the latter. The amount actually voted to the king for life in 1697 was £700,000, and the same vote was made at the commencement of the reign of Queen Anne and George I. By the beginning of the reign of George II. the revenue appropriated to the civil list was found to have produced £830,000, and this sum was voted on the accession of George II. Besides the regular vote, grants had been frequently made to defray debts incurred in the expenditure of the sovereign. On the accession of George III. the civil list was fixed at £800,000, but instead of being paid out of appropriated revenues in which the crown lands were included, these were surrendered, and it was charged on the ordinary taxation. Large extra grants had to be made during this reign. In the reign of William IV. the list was cleared of all salaries, &c., upon it, and placed at £510,000, including a pension list of £75,000. On the accession of Victoria a civil list of £385,000 per annum was settled on her majesty for life, the civil list being limited to the support of her majesty's household and the maintenance of the dignity of the crown. In place of the grant of £75,000 for civil list pensions, her majesty was empowered to grant every year new pensions on the civil list to the amount of £1200. Many continental states have a fixed civil list; that of Russia is £1,410,000; of Turkey, £920,000; of Austria, 730,000; of Prussia, £675,000, to which an additional grant of £225,000 has recently been added, making a total of £900,000.

**Civil Service**, collectively, all offices under government except those directly connected with the army and navy. In Great Britain.

it comprises such departments as the Home Office, the Foreign Office, the Treasury, the War Office, Admiralty, Post-office, Customs, Inland Revenue, &c. Formerly appointments to the civil service in Great Britain were entirely in the gift of the executive government, and were obtained by influence, while the bestowal of them was used as a means of gaining parliamentary support on behalf of the government. Originally it was not necessary that the candidate should pass any examination before entering on his duties, but in 1855 a system of examinations was instituted to test the efficiency of candidates, and in 1870, by an order in council, it was directed that appointments in the civil service should (with certain exceptions) be filled by open competition, as was already the case with appointments in the Indian civil service. The examining commissioners are required to ascertain that the candidate is within the limits of age prescribed; that he is free from any physical defect or disease which would be likely to interfere with the proper discharge of his duties; that his character is such as to qualify him for public employment; and that he possesses the requisite ability for the proper discharge of his official duties, this being tested by a six months' probation after the candidate has been successful in the open competition. Appointments to ordinary clerkships in the civil service are divided into two grades or divisions, the limits of age for the higher being 18 to 24, for the lower 17 to 20. The salary of clerks in the lower division regularly begins at £80 and rises by the addition of £15 every three years to £200. In the higher division the salaries are very much better, but the examinations are correspondingly severe. A preliminary examination to test writing, orthography, and English composition must be passed before a candidate is admitted to compete. There are also boy clerkships, the age being over 15 and under 17. For a number of appointments open to competition special qualifications, scientific or technical, and special limits of age, are laid down. Certain appointments in the post-office and telegraph service are open to young women. A person may be appointed without preliminary examination, in the event of any appointment requiring a person of mature age possessed of special qualifications. Superannuation allowances are granted on the following general scale: for ten and under

eleven years' service ten-sixtieths of the annual salary and emoluments of the office, an additional sixtieth being added for each year's additional service until the completion of forty years, when no further addition to the retiring allowance is to be made. The Indian civil service, for which examinations are held in Britain, is a branch by itself; some of the Indian appointments are worth £5000 a year. In the *Civil Service Estimates* of Britain are included all the expenditure not incurred for the support of the army and navy, such as that required for education, law and justice, public works, &c., besides the salaries of those in the various public departments. The total expenditure is usually about £18,000,000 annually.—In the United States civil service the system prevailed by which the party in power conferred the various appointments on such of its members as had most influence, or had done it most service, there being thus usually a great change of officials with each change of president, on the understood principle that 'to the victors belong the spoils.' Some attempts at establishing a better state of matters have of late years been made. In 1883 a bill introduced into congress by Senator Pendleton, of Ohio, became a law. The act creates a commission, composed of three members, appointed by the president and senate, known as the U. S. Civil Service Commission. They were to provide rules for open competitive examinations for testing the fitness of applicants for the public service. Under the administration of Cleveland (both terms), Harrison and McKinley it has been greatly extended and now embraces most of the departments. Examining boards are in the large cities.

**Clackman'n**, the smallest county of Scotland, containing little more than 47 square miles, or 30,477 acres; situate on the north side of the Forth, by which it is bounded s.w., while on nearly all the other sides it is inclosed by the counties of Perth and Stirling. The north part of the county is occupied by the Ochil Hills, which are largely given up to sheep-farming, but the other portions are comparatively level and exceedingly fertile, yielding large crops of wheat and beans. The minerals are valuable, especially coal, which abounds. There are also some extensive ironworks, and some large breweries and distilleries; woollens are also manufactured, and tanning, glass-blowing, &c., carried on. The principal towns are Alloa, Tillicoultry, Dollar, and



Clackmannan. The last is nominally the county town, but Alloa is really so. Pop. of co. 28,433; of tn. 1503.

**Cladium**, a genus of plants, consisting of twenty-one species of wide distribution, nat. order Cyperaceæ (or sedges). The *C. Mariscus*, or twig-rush, is a British perennial with keeled leaves, having a sharp point and prickly serratures. It is very common in certain fenny districts in Cambridgeshire, &c., and is used for thatching.

**Clairac** (klā-rāk), a town, France, department Lot-et-Garonne, on the Lot. It was the first town in the south of France to declare in favour of the Reformation. Pop. 2388.

**Clairaut** (klā-rō), ALEXIS CLAUDE, mathematician, born at Paris in 1713. In his eleventh year he composed a treatise on the four curves of the third order, which, with his subsequent *Recherches sur les Courbes à double Courbure*, 1731, procured him a seat in the Academy at the age of eighteen. He accompanied Maupertuis to Lapland, to assist in measuring an arc of the meridian, and obtained the materials for his work *Sur la Figure de la Terre*. In 1752 he published his *Théorie de la Lune*, and in 1759 calculated the perihelion of Halley's comet. He died in 1765. A brother, who died at the age of twelve, published in his ninth year a treatise entitled *Diverses Quadratures Circulaires Elliptiques*.

**Claire**, ST., or SANTA CLARA, ORDER OF, founded in 1212 by a lady of this name, of noble birth, born at Spoleto, Italy, in 1193, died in 1253, and canonized in 1255. The order is divided into a severe sect, the Damianists, and a more moderate sect, the Urbanists. It has numerous convents in Europe and America.

**Clairvaux** (klār-vō), a village, France, department of Aube, celebrated for its magnificent abbey, founded in 1114 or 1115, by St. Bernard, but suppressed at the revolution. The existing buildings have been converted into an immense house of correction. See *Cistercians*.

**Clairvoyance** (that is 'clear-seeing'), an alleged faculty by which certain persons in certain states, or under certain conditions, are said to be able to see things by some sort of mental or spiritual vision apart altogether from the sense of sight; thus they are said to be able to tell what an absent person is doing, to describe the contents of a closed box, &c. It is claimed that clairvoyance is the result of a kind of natural

state of trance, or may be induced by mesmerism; and in evidence of its existence in ancient times the utterances of prophets, sybils, &c., have been adduced.

**Clam**, the popular name of certain bivalvular shell-fish of various genera and species, e.g. the thorny clam (*Chama Lazarus*), the yellow clam (*Tridacna crocċa*), the giant clam (*T. gigas*), the common clam of the United States (*Mya arenaria*), &c. The giant clam has the largest shell known, and the animal is used as food in the Pacific. The common U. S. clam is also much used for food.

**Clamecy** (klām-sē), a town of France, department Nièvre, on the Yonne. It has a fine church, founded in 1497. Woodrafts for the supply of Paris with fire-wood are made up here, and floated down the Yonne and Seine. Pop. 5622.

**Clan** (Gaelic, a tribe or family), among the Highlanders of Scotland, consisted of the common descendants of the same progenitor, under the patriarchal control of a chief, who represented the common ancestor. The name of the clan was frequently formed of that of the original progenitor with the affix *mac* (son): thus the MacDonalds were the sons of Donald, and every individual of this name was considered a descendant of the founder of the clan, and a brother of every one of its members. The chief exercised his authority by right of primogeniture, as the father of his clan: the clansmen revered and served the chief with the blind devotion of children. The clans each occupied a certain portion of the country, and hostilities with neighbouring clans were extremely common. Next in rank to the chief were a certain number of persons, commonly near relations of the chief, to whom portions of land were assigned, during pleasure or on short leases. Each of these usually had a subdivision of the clan under him, of which he was chieftain, subject, however, to the general head of the sept. The jurisdiction of the chiefs was not very accurately defined, and it was necessary to consult, in some measure, the opinions of the most influential clansmen and the general wishes of the whole body. It was latterly the policy of the government in Scotland to oblige the clans to find a representative of rank to become security at court for their good behaviour; the clans who could not procure a suitable representative, or who were unwilling to do so, were called broken clans, and existed in a sort of outlawry.

The most notable instance of a proscribed and persecuted clan was that of the ancient clan MacGregor, who long continued to hold their lands by the *coir a glaive*, or right of the sword. The rebellions of 1715 and 1745 induced the British government to break up the connection which subsisted between the chiefs and the clansmen. The hereditary jurisdiction of the chiefs was therefore abolished, the people disarmed, and even compelled to relinquish their national dress. Few traces of this institution now remain, except such as have a merely sentimental character; thus all those who possess the same clan name may still talk of their 'chief,' though the latter have now neither land nor influence.

**Clap'ham**, a southern suburban district and parl. borough of London. Clapham Common is a fine open space of over 200 acres. Pop. 1891, 96,952.

**Clap-net**, a ground-net used by bird-catchers, consisting of two equal parts about 12 yards long by  $2\frac{1}{2}$  wide, and each having a slight frame. They are placed about four yards apart, and are pulled over by a string so as to inclose any birds on the intervening space.

**Clap'perton**, HUGH, African traveller, born in Annan, Dumfriesshire, in 1788. He entered the merchant service, but was impressed into the navy, in which he became a lieutenant in 1816. He then accompanied Dr. Oudney and Lieutenant Denham to Africa, where he remained till 1825, returning with valuable information, although the disputed question of the course of the Niger was left undecided. On his return to England Clapperton received the rank of captain, and immediately engaged in a second expedition, to start from the Bight of Benin. Leaving Badagry, Dec. 1825, he penetrated to Katunga, within thirty miles of the Quorra or Niger, but was not permitted to visit it. At Soccatoo the Sultan Bello refused to allow him to proceed to Bornu, and detained him a long time in his capital. The disappointment preyed upon him, and he died, April 1827, at Chungary, a village near Soccatoo. He was the first European who traversed the whole of Central Africa from the Bight of Benin to the Mediterranean.

**Claqueurs** (klà-keurz), the name given in Paris to a company of persons paid for applauding theatrical performances, more especially on the production of any new piece. They were sometimes called *chevaliers-du-lustre*, from mustering in great

force near the centre of the pit, below the chandelier.

**Clara**, SANTA. See *Claire*.

**Clare**, a maritime county, Ireland, province Munster (capital, Ennis), between Galway Bay and the Shannon estuary; area, 827,994 acres, of which 140,000 are under tillage. The surface is irregular, rising in many places into mountains of considerable elevation, particularly in the E., W., and N.W. districts. Oats, potatoes, wheat, and barley are the principal crops. The chief minerals are limestone, lead, and slate, but the produce of the county is almost wholly agricultural. Lakes are numerous, but generally of small size, and the county is deficient in wood. The condition of the smaller cottiers is extremely bad. The salmon-fisheries are valuable, and there are immense oyster-beds in some places. Clare returns two county members to parliament. Pop. in 1841, 286,394; in 1891, 123,859.

**Clare**, JOHN, 'the Northamptonshire peasant poet,' born in 1793 at Helpstone, near Peterborough, where his father was a farm-labourer. He led a rambling, unsteady life until 1818, when he was obliged to accept parish relief. In 1820 his *Poems Descriptive of Rural Life and Scenery* met with a favourable reception, and the issue of his *Village Minstrel* in 1821 won him many friends. A subscription furnishing him with £45 annually was, however, dissipated by 1823, and his *Shepherd's Calendar* (1827), which he hawked himself, was not a success. He brought out a new work, the *Rural Muse*, in 1835, but became insane shortly afterwards, the remainder of his life, from 1837 to 1864, being passed in the Northampton Lunatic Asylum. Clare was a genuine poet, and his pictures of rural life are eminently truthful and pleasing.

**Clare College**, a college of the University of Cambridge, founded in 1326 by Elizabeth, sister of the Earl of Clare. It has much-admired buildings in the Renaissance style.

**Clare Island**, an island of Ireland, county Mayo. It has a lofty lighthouse.

**Claremont**, Sullivan co., N. H., a pleasant town, on Connecticut R. Pop. 5565.

**Clarence**, GEORGE, DUKE OF, son of Richard, duke of York, and brother of Edward IV., king of England. On his brother's accession, in 1461, he was created Duke of Clarence, and in 1462 Lord-lieutenant of Ireland, but afterwards joined the

disaffected Warwick, and married his daughter. On the eve of battle he rejoined his brother, and was afterwards involved in a quarrel with his brother Richard, who had married Warwick's younger daughter, about the inheritance of their father-in-law. On the death of his wife Clarence sought the hand of Mary of Burgundy, but Edward interposed and a serious breach ensued. A gentleman of the household of Clarence having at this time been condemned for using necromancy against the king, Clarence interfered with the execution of the sentence. He was impeached by the king in person, condemned in 1478, and secretly made away with in the Tower. The tradition that he was drowned in a butt of malnsey wine is unsupported by evidence.

**Clarencieux.** See *Kings-of-Arms*.

**Clar'endon**, CONSTITUTIONS OF, a code of laws adopted in the tenth year of Henry II. (January, 1164), at a council of prelates and barons held at the village of Clarendon, Wiltshire. These laws, which were finally digested into sixteen articles, were brought forward by the king as 'the ancient customs of the realm,' and were enacted as such by the council, but they really involved a great scheme of administrative reform in the assertion of the supremacy of the state over clergy and laity alike. The power of the ecclesiastical courts was restricted, the crown secured the right of interference in elections to ecclesiastical offices, appeals to Rome were made dependent on the king's leave, ecclesiastical dignitaries were deprived of their freedom to leave the country without the royal permission, &c. Becket signed them, but retracted his signature on the refusal of the Pope Alexander III. to countenance them. Becket's murder followed, and to effect a reconciliation with the pope Henry promised the amendment of the Constitutions of Clarendon. They were accordingly modified in 1176 at Northampton in favour of the church, but they are not the less to be regarded as containing the germ of the ecclesiastical policy of Henry VIII.

**Clar'endon**, EDWARD HYDE, EARL OF, Lord High-chancellor of England, son of a private gentleman of Dinton, Wilts, where he was born in 1608. After studying at Oxford and at the Middle Temple he married, in 1629, the daughter of Sir George Ayliffe, and, in 1632, Frances, daughter of Sir Thomas Aylesbury. He commenced his political career in 1640 as member for

Wootton-Basset, and was again returned to the Long Parliament (November, 1640) by the borough of Saltash, at first acting with the more moderate of the popular party, but gradually separating himself from the democratic movement until, by the autumn of 1641, he was recognized as the real leader of the king's party in the house. Upon the breaking out of the civil war he joined the king at York, was knighted, made privy-councillor, and appointed chancellor of the exchequer. After vainly attempting to bring about a reconciliation between the contending parties he accompanied Prince Charles to Jersey, where he began his *History of the Rebellion*, and wrote answers in the king's name to the manifestoes of the parliament. In September, 1649, he rejoined Charles at the Hague, and was sent by him on an embassy to Madrid. Soon after his return he resumed the business of the exiled court, first at Paris, and afterwards at the Hague, where, in 1657, Charles II. appointed him lord-chancellor. After Cromwell's death he contributed more than any other man to promote the Restoration, when he was placed at the head of the English administration. In 1660 he was elected Chancellor of the University of Oxford, and in 1661 was created Baron Hyde, Viscount Cornbury, and Earl of Clarendon. The marriage of the Duke of York with his daughter, Anne Hyde, confirmed for a time his power, but in 1663 Lord Bristol made an unsuccessful attempt to impeach him, his influence with the king declined, and his station as prime-minister made the nation regard him as answerable for the ill success of the war against Holland, the sale of Dunkirk, &c. The king's displeasure deepened when his plan of repudiating his wife and marrying the beautiful Lady Stuart was defeated by Clarendon, who effected a marriage between this lady and the Duke of Richmond. The king deprived him of his offices, an impeachment for high treason was commenced against him, and he was compelled to seek refuge in Calais. He lived six years at Montpellier, Moulins, and Rouen, where he died in 1674. His remains were afterwards removed to Westminster Abbey. During his second exile he completed his *History of the Rebellion* in autobiographical form, wrote a biographical Continuation in defence of his administration, and sought to vindicate Lord Ormonde by a *History of the Rebellion in Ireland*.

**Clarendon, GEORGE WILLIAM FREDERICK VILLIERS, EARL OF**, eldest son of the Hon. George Villiers, was through his mother indirectly related to the Hydes, the family of the great Earl of Clarendon. He was educated at Cambridge, entered the civil service at an early age, and in 1820 was attached to the embassy at St. Petersburg. In 1823 he was appointed to a commissionership of the excise in Dublin. In 1831 he was sent to France to negotiate a commercial treaty, and in 1833, as minister plenipotentiary at Madrid, was instrumental in negotiating the Quadruple Alliance, signed in 1834. Having succeeded to his uncle's title in 1838 he returned home in the following year, and in Jan. 1840 was appointed lord privy-seal, and in October chancellor of the duchy of Lancaster. He supported the repeal of the corn-laws and the reduction of duties, and in 1846 was appointed president of the board of trade in Lord J. Russell's ministry, and in the following year Lord-lieutenant of Ireland. He resigned with his party in 1852, when the Earl of Derby took office, but soon after the formation of the Aberdeen ministry he was appointed to the foreign secretaryship, which he held until Jan. 1855. After a few weeks' interval he returned to the post under Lord Palmerston, and retained it until 1858, being one of the signatories of the Treaty of Paris. In 1861 Clarendon was sent as ambassador-extraordinary to the coronation of the King of Prussia, and in 1864 was appointed chancellor of the duchy of Lancaster. In the following administration, under Russell, he resumed the direction of the foreign office. He was sent in 1868 on a special mission to the pope and the King of Italy, and again occupied the post of foreign secretary in the Gladstone ministry till his death, in June, 1870.

**Clar'endon Press**, the press of the University of Oxford. In January, 1586, delegates *de impressione librorum* were appointed by the Convocation of the university, Joseph Barnes and others after him being styled 'Printer to the University.' In 1633 Archbishop Laud procured a large license in printing to the university, with a view to the publication of Bodleian MSS., the work being carried on first in hired premises; then from 1669 in the Sheldonian Theatre; from 1713 in premises built for the purpose; and from 1825 in new and larger offices. The management of the printing-office is committed to a delegacy consisting of the vice-

chancellor and ten other members of Convocation, nominated by the vice-chancellor and proctors, five for life and five for a term of seven years. From 1780 the university has received into partnership two or more skilled persons who superintend the concern. The north, called the 'learned' or classical side, is set apart for the printing of university documents and authorized books, the 'south' for the printing of Bibles and Prayer-books.

**Claret**, the name given in Britain, America, &c., to the red wines of Bordeaux. A large quantity of wine produced in California is also called by this name, and is of a very excellent quality. The name has become generic. See *Bordelais Wines*.

**Clar'ichord**, or CLAV'ICHORD, an old keyed instrument, somewhat in the form of a spinet. Sometimes called the *dumb spinet*.

**Clarifica'tion**, or the separation of the insoluble particles that prevent a liquid from being transparent, may be performed by *deuration*, in which the liquid is allowed to stand until the particles are precipitated, and then decanted; by *filtration*, or straining through wool, sand, charcoal, &c.; or by *coagulation*, in which the albumen contained in or added to the liquid is solidified and precipitated by the action either of heat or of acids, the extraneous substances being precipitated with it. See also *Fining*.

**Clar'inet**, or CLARINET, a wind-instrument of the reed kind, played by holes and keys. Its lowest note is E below the F clef, from which it is capable, in the hands of good performers, of ascending more than three octaves. The keys of C and F, however, are those in which it is heard to most advantage, though there are B flat, A, D, B, and G clarinets.

**Clar'ion**, a musical instrument of the trumpet kind, with a narrower tube and a higher and shriller tone than the common trumpet.

**Clark, SIR JAMES, BART.**, British physician, born in Banffshire in 1788. After taking his arts degree at Aberdeen he studied medicine at Edinburgh, served in the navy as surgeon from 1809 till 1815, when he returned to Edinburgh. He took his degree of M.D. in 1817, practised in Rome from 1818 to 1826, returned to England in 1826, became physician to the Duchess of Kent in 1835, and on the accession of Queen Victoria was appointed first physician in ordinary to the queen, and shortly afterwards made a

baronet. He died in 1870. His chief works were treatises on the Sanative Influence of Climate (1829), and on Pulmonary Consumption and Scrofula (1835).

**Clarke, ADAM**, Methodist divine and scholar, born in 1762 in county Londonderry, Ireland. He became an itinerant Methodist preacher, and continued to travel in various circuits till 1805, after which he resided chiefly in London, dying of cholera at Bayswater in 1832. He was learned in the Oriental languages, and published a commentary on the Scriptures (1810-26), a Bibliographical Dictionary, and other works.

**Clarke, CHARLES COWDEN**, English writer, born at Enfield, Middlesex, in 1787. He was one of the minor members of the Shelley, Keats, and Leigh Hunt group. His publications include his Hundred Wonders (1814), Adam the Gardener (1834), Shakespeare Characters (1863), and Molière Characters (1865). He is best known, however, by the edition of Shakespeare which he annotated in conjunction with his wife, and by the Shakespeare Key (1879). He died in 1877.

**Clarke, EDWARD DANIEL**, English traveller and mineralogist, born in Sussex in 1769, entered Jesus College, Cambridge, in 1786; and was made a fellow in 1798. In 1799 he set out on an extensive tour through Europe, Asia Minor, Syria, Egypt, &c., securing for English institutions many valuable objects, such as the celebrated manuscript of Plato's works, with nearly 100 others, a colossal statue of the Greek goddess Demeter (Ceres), and the famous sarcophagus of Alexander the Great. In 1807 he commenced a course of lectures on mineralogy at Cambridge, and in 1808 a professorship of mineralogy was instituted there in his favour. He died in 1822. A complete edition of his works appeared in 1819-24, under the title of Travels in Various Countries of Europe, Asia, and Africa.

**Clarke, SAMUEL, D.D.**, an English theological and philosophical writer, born in 1675 at Norwich, where his father was an alderman; educated at Caius College, Cambridge. He became chaplain to Dr. More, bishop of Norwich, and between 1699 and 1701 published Essays on Baptism, Confirmation, and Repentance, replied to Toland's Amyntor, and issued a paraphrase of the Gospels. He was then presented with two livings, and in 1704 and 1705 twice delivered the Boyle lectures at Oxford on The Being and Attributes of God, and on The Evi-

dences of Natural and Revealed Religion. In 1706 he published a letter to Mr. Dodwell on the Immortality of the Soul, and a Latin version of Newton's Optics. He was then appointed rector of St. Bennet's, London, and shortly afterwards rector of St. James's and chaplain to Queen Anne. In 1712 he edited Cæsar's Commentaries, and published his Scripture Doctrine of the Trinity, which became a subject of much controversy and of complaint in the Lower House of Convocation. His chief subsequent productions were his discussions with Leibnitz and Collins on the Freedom of the Will, his Latin version of part of the Iliad, and a considerable number of sermons. He died in 1729. His philosophic fame rests on his *a priori* argument for the existence of God, his theory of the nature and obligation of virtue as conformity to certain relations involved in the eternal fitness of things, and his opposition to Hobbes, Spinoza, Locke, Leibnitz, and others.

**Clarke's River**, a river of the United States, rising in the Rocky Mountains, and after a winding N.W. course of about 700 miles, falling into the Columbia, in Washington.

**Clarkson, THOMAS**, an English emancipationist, born in 1760 at Wisbeach, Cambridgeshire. He was originally intended for the church, and studied at St. John's College, Cambridge, where he gained the vice-chancellor's prize for a Latin essay on the theme, 'Anne liceat invitòs in servitutum dare?' (Is it lawful to make slaves of men against their will?) His researches for this dissertation roused in him a passionate antagonism to the slave-trade, and he allied himself with the Quakers and with Wilberforce. While the latter advocated the cause in parliament, Clarkson conducted the agitation throughout England, even crossing to France to obtain the co-operation of the National Convention. His labours went far to secure the prohibition of the slave-trade in 1807 and the emancipation act of 1833. His death took place in 1846. His literary works comprise: A Portraiture of Quakerism (1806); History of the Abolition of the Slave Trade (1808).

**Clarksville**, Montgomery co., Tenn., a prosperous town, has 3 banks, and tobacco warehouses, iron mines, etc. Pop. 7924.

**Clary** (*Salvia Sclarea*), a plant of the *Salvia* or sage genus, used for flavouring soups and confectionery. Its flowers were used with brandy, sugar, cinnamon, and a

little ambergris to make *clary water*, regarded as a cardiac to help digestion.

**Classic**, a term derived from L. *classici*, the name given to the citizens belonging to the first or highest of the six classes into which the Romans were divided. Hence the Greek and Roman authors have been in modern times called *classics*, that is, the excellent, the models. The Germans, however, soon gave the word *klassisch* (classical) a wider sense, making it embrace: 1, the standard works of any nation; and 2, ancient literature and art, in contradistinction to the modern; and their example was followed by both the British and the French. A third use of the term, in contradistinction to Romantic, is scarcely comprised under those cited, implying adherence to the established literary or artistic convention of some previous period, as opposed to the insurgence of new elements shaping a new convention. In this sense classic usually implies the predominance of form over emotion and thought, while its antonym Romantic implies the predominance of emotion and the departure from the old formal standards. From its vagueness in this regard many writers, such as G. H. Lewes, have vainly proposed to dispense with the term.

**Classification** is commonly defined as the arrangement of things, or of our notions of them, according to their resemblances or identities; and its general object is to provide that things shall be thought of in such groups, and the groups in such an order, as will best promote the remembrance and ascertainment of their laws. As any collection of objects may be classified in a variety of ways, no fixed method can be laid down; but it will be obvious that in correct classification the definition of any group must hold exactly true of all the members of that group and not of the members of any other group. The best classification again will be that which shall enable the greatest possible number of general assertions to be made; a criterion which distinguishes between a natural and an artificial system of classification. Classification is perhaps of most importance in natural history—for example, botany and zoology. In the former the artificial or Linnæan system long prevailed, in opposition to the modern or natural.

**Claude** (klōd), JEAN, a French Protestant preacher and professor of the college at Nîmes, born in 1619. He entered into controversy with Arnauld and Bossuet, and on the revocation of the Edict of Nantes took

refuge in the Hague, where he died in 1687. His chief work was the *Défense de la Réformation* (1673).

**Claude** (klōd), ST., a town, France, department of the Jura, at the confluence of the Bienne and Tacon. It is the see of a bishop, and has a handsome cathedral and communal college, and a fine promenade along the Bienne. It is celebrated for turnery, hardware, musical-boxes, &c. Pop. 8216.

**Claude Lorraine**, a landscape-painter whose real name was *Claude Gélée*, but who was called *Lorraine* from the province where he was born in 1600. When twelve years old he went to live with his brother, an engraver in wood at Friburg, went from him to study under Godfrey Waats at Naples, and was afterwards employed at Rome by the painter Agostino Tassi, to grind his colours and do the household drudgery. On leaving Tassi he travelled in Italy, France, and Germany, but settled in 1627 in Rome, where his works were greatly sought for, and where he lived much at his ease until 1682, when he died of the gout. The principal galleries of Italy, France, England, Spain, and Germany are adorned with his paintings; that on which he himself set the greatest value being the painting of a small wood belonging to the Villa Madama (Rome). He excelled in luminous atmospheric effects, of which he made loving and elaborate studies. His figure work, however, was inferior, and the figures in many of his paintings were supplied by Lauri and Francesco Allegrini. He made small copies of all his pictures in six books known as *Libri di Verità* (Books of Truth), which form a work of great value (usually called the *Liber Veritatis*), and much esteemed by students.

**Claudia'nus**, CLAUDIUS (commonly called Claudian), a Latin poet, native of Alexandria, lived at the end of the 4th and beginning of the 5th century after Christ, under the Emperor Theodosius and his sons. He did much to recall to dying Rome the splendours of the Augustan literature, ranking considerably above any other of the later poets. Besides several panegyric poems on Honorius, Stilicho, and others, we possess two of his epic poems, the Rape of Proserpine, and an unfinished War of the Giants, eclogues, epigrams, and occasional poems.

**Clau'dius**, often also called *Clodius*, the name of a distinguished Roman family of antiquity. See *Appius Claudius*.

**Clau'dius**, or, in full, TIBERIUS CLAUDIUS DRUSUS NERO GERMANICUS, a Roman em-

peror, son of Claudius Drusus Nero, stepson of Augustus and Antonia, the daughter of Augustus's sister; born at Lyons (10 B.C.). He lived in privacy, occupying himself with literature, the composition of a Roman history, and other works, until the murder of Caligula, when he was dragged from his hiding-place and proclaimed emperor (41 A.D.). The early years of his reign were marked by the restoration of the exiles, the embellishment of Rome, the addition of Mauritania to the Roman provinces, and successes in Germany and Britain. But latterly he became debauched, left the government to his wives, and in particular to Messalina, who with his freedmen committed the greatest enormities. He was poisoned by his fourth wife, Agrippina (mother of Nero), A.D. 54.

**Claudius, MATTHIAS**, a German poet, born in 1741 near Lübeck. His works, which are on a great variety of subjects, are all of a popular character, and many of his songs have become a part of the national melodies. In later life he became a convert to religious mysticism, and died at Hamburg in 1815, after having filled several public offices.

**Clausenburg.** See *Klausenburg*.

**Clausthal.** See *Klausthal*.

**Clava'ria**, a genus of fungi, some species of which are edible.

**Claverhouse.** See *Graham, John*.

**Clavichord.** See *Clarichord*.

**Clav'icle**, the collar-bone, a bone forming one of the elements of the shoulder girdle in vertebrate animals. In man and sundry quadrupeds there are two clavicles each joined at one end to the scapula or shoulder-bone, and at the other end to the sternum or breast-bone. In many quadrupeds the clavicles are absent or rudimentary, while in birds they are united in one piece popularly called the 'merry-thought.'

**Clavicorn Beetles** (*Clavicornes*), a large family of coleopterous insects, distinguished by the club-shaped character of the antennæ. Burying-beetles and bacon-beetles are typi-

cal examples, and there are aquatic as well as terrestrial species.

**Clavigero** (klä-vi-hä'rō), FRANCESCO SAVERIO, a Spanish historian, born at Vera Cruz, Mexico, about 1720. He was educated as an ecclesiastic, and resided thirty-six years in the provinces of New Spain, where he acquired the languages of the Mexicans and other indigenous nations, collected many of their traditions, and studied their historical paintings and other monuments of antiquity. On the suppression of the Jesuits by the Spanish government in 1767 Clavigero went to Italy, the pope assigning him a residence in Cesena, where he wrote his Mexican History, and died in 1793.



Tiberius Claudius.

**Clay**, the name of various earths, which consist of hydrated silicate of aluminium, with small proportions of the silicates of iron, calcium, magnesium, potassium, and sodium. All the varieties are characterized by being firmly coherent, weighty, compact, and hard when dry, but plastic when moist, smooth to touch, not readily diffusible in water, but when mixed not readily subsiding in it. Their tenacity and ductility when moist and their hardness when dry has made them from the earliest times the materials of bricks, tiles, pottery, &c. Of the chief varieties *porcelain-clay*, *kaolin*, or *china-clay*, a white clay with occasional gray and yellow tones, is the purest. *Potter's-clay* and *pipe-clay*, which are similar but less pure, are generally of a yellowish or grayish colour, from the presence of iron. *Fire-clay* is a very refractory variety, always found lying immediately below the coal; it is used for making fire-bricks, crucibles, &c. *Loam* is the same substance mixed with sand, oxide of iron, and various other foreign ingredients. The *boles*, which are of a red or yellow colour from the presence of oxide of iron, are distinguished by their conchoidal fracture. The *ochres* are similar to the boles, containing only more oxide of iron. Other varieties are *fuller's-earth*, *Tripoli*, and *boulder-clay*, the last a hard clay of a dark-brown colour, with rounded masses of rock of all sizes embedded in it, the result of glacial action. The distinctive property of clays as ingredients of the soil is their power of absorbing ammonia and other gases and vapours generated on fertile and manured lands; indeed no soil will long remain fertile unless it has a fair proportion of clay in its composition. The best wheats both in Britain and the European continent

are grown on calcareous clays, as also the finest fruits and flowers of the rosaceous kind. See the separate articles on the chief varieties.

**Clay, HENRY**, an American statesman, born in Hanover co., Va., in 1777. After acting as clerk in two or three state offices he commenced business in 1797 as a lawyer at Lexington, Kentucky. He soon became famous as a public speaker, and at the age of twenty-six was a member of the Kentucky legislature. In 1806 he was elected to the United States Senate; and in 1811 to the House of Representatives, where he was at once made speaker. In 1814 he proceeded to Europe and acted as one of the commissioners for adjusting the treaty of peace at Ghent between America and Great Britain. He was an unsuccessful candidate for the presidency in 1824, 1832, and 1844. He is best known for his endeavours to shut out European influences from America, and in connection with the 'Missouri Compromise of 1820,' restricting slavery to the states south of lat. 36° 30' N.; and another similar compromise of 1850 regarding the admission of California, and establishment of territorial governments in New Mexico, Utah, &c. He died at Washington in 1852. Clay was unquestionably one of the greatest orators America has produced; a splendid party chief, idolized by his followers.

**Claymore**, formerly the large two-handed, double-edged sword of the Scotch Highlanders; now a basket-hilted, double-edged broad-sword.

**Clay-slate**, in geology, a rock consisting of clay which has been hardened and otherwise changed, for the most part extremely fissile and often affording good roofing-slate. In colour it varies from greenish or bluish gray to lead colour.

**Clayton, JOHN MIDDLETON**, jurist, born in Sussex Co., Del., 1796, educated at Yale, studied law, became U. S. Senator, and Sec. of State 1850; negotiated treaty with England (see next article); died Nov., 1856.

**Clayton-Bulwer Treaty**, a treaty between Britain and the U. States concluded in 1850, and having reference to the construction of a ship canal across the Isthmus of Panamá. Both parties agreed not to erect fortifications here, nor to acquire any part of the Central American territory.

**Cleanthes**, a Greek Stoic philosopher, born at Assos about 300 B.C. He was a disciple of Zeno for nineteen years, and succeeded him in his school. He died of

voluntary starvation at the age of eighty. Only some fragments of his works are extant.

**Clear, CAPE**, a promontory 400 feet high at the southern extremity of Clear Island, and the most southern point of Ireland, about 7½ miles south-east of Baltimore, county Cork.—Clear Island is about 3¼ miles long and about 1 broad. It is wild and romantic, and has a fishing population of over 1000.

**Clearance of Vessels**, the examination of them by the proper custom-house officers, and the giving of a certificate that the regulations have been duly complied with. Vessels are said to clear inwards or outwards according as they arrive or set sail.

**Clearing-house**, an institution connected with banks and railways. In the former case it is an establishment in large cities where there are many banks, to which each bank connected with it sends every day in order to have its business with the other banks adjusted. The sums due by and to the banks among themselves are here set off against each other and the balance paid or received. In London the balance used to be settled in cash or Bank of England notes. Now, however, the various banking companies and the clearing-house itself have accounts at the Bank of England, and the balances are settled by transfers from one account to another. The clearing-house system was introduced by the London city private banking firms in 1775, but the joint-stock companies were in 1854 permitted to share its advantages, and it has been extended to the provincial banks through their London agents. The system has also been adopted in the larger provincial towns, and in New York and other large American cities it is also in full operation. In 1874 it was, by the formation of the London Stock Exchange clearing-house, extended to the clearance of quantities of stock; and the principle was also utilized by the Liverpool Cotton Brokers' Association for the settlement of business in connection with sales of cotton 'to arrive.'—The *Railway Clearing-house* is an association instituted to allow the various companies to carry on their traffic over different lines. Thus a passenger can purchase one single ticket which will carry him over lines belonging to several companies, and parcels are conveyed through without additional booking, fresh entries, and consequent delay, the claims of the different companies being adjusted in the clearing-



house, which is maintained at the common expense.

**Clearing-nut** (*Strychnos potatorum*), a small tree of the same genus as the nux vomica, common in Indian forests. Its seeds being rubbed on the inside of a vessel containing turbid water speedily precipitate the impurities, this result being due it is said to the clarifying effect of the albumin and casein they contain.

**Clear-story.** See *Clere-story*.

**Cleator Moor**, a town of England in Cumberland, 4 miles S.E. of Whitehaven, with coal-mines and iron furnaces. Pop. 9464.

**Cleavage**, the manner or direction in which substances regularly cleave or split. The regular structure of most crystallized bodies becomes manifest as soon as they are broken. Each fragment presents the form of a small polyhedron, and the very dust appears under the microscope an assemblage of minute solids, regularly terminated. The directions in which such bodies thus break up are called their planes of cleavage; and the cleavage is called *basal*, *cubic*, *diagonal*, or *lateral* (or *peritomous*), according as it is parallel to the base of a crystal, to the faces of a cube, to a diagonal plane, or to the lateral planes. In certain rocks again there is a tendency to split along planes which may coincide with the original plane of stratification, but which more frequently cross it at an angle. This tendency is the consequence of the readjustment by pressure and heat of the components of rocks, which is one of the phases of metamorphism.



**Clea'vers**, CLIV'ERS, or GOOSE-GRASS (*Galium Aparine*), a common species of the bed-straw genus of plants, with hispid stem, leaves, and fruit, common in hedges and among bushes. It is called cleavers from the readiness with which it adheres to one's clothes, and goose-grass because geese are said to be fond of it. An extract of this plant has been used in cutaneous diseases.

**Cleckhea'ton**, a township, England, county York, West Riding; pleasantly situate on a declivity in the Spen valley, 10 miles W. Leeds. The industries include the worsted and machine-card trades, machine-making, engineering works, &c. Pop. 11,826.

**Cleef** (kläf).—(1) JOSEPH VAN, surnamed *the Fool*, born at Antwerp in 1480, one of the most celebrated painters of his time, who in regard to beauty of colouring may challenge comparison with the Italian masters. He died insane in 1529.—(2) JOHN, a painter, born at Rome in 1646, belongs to

the Flemish school, of which he is one of the most eminent masters. His works show more breadth of style than skill in colouring. He died in 1716.

**Clef** (French for *key*), in music, a sign placed on a line of a staff, and which determines the pitch of the staff and the name of the note on its lines. There are three clefs

now in use: the *treble* or G clef,  written on the second line; the *mean* or C clef, 

which may be placed on the first, second, third, or fourth lines; and the *bass* or F clef,  seated on the fourth line. The mean clef is very seldom used in writing vocal music in England.

**Cleg**, a name applied to various insects which are troublesome to horses, cattle, and even to man from their blood-sucking propensities. Such are the great horse-fly, gad-fly, or breeze (*Tabanus bovinus*), the *Chrysops caxutiens*, and the *Hæmatopota pluvialis*.

**Clem'atis**, a genus of woody climbing plants of the order Ranunculaceæ. The most common species, *C. Vitalba*, virgin's bower or traveller's joy, is conspicuous in the hedges both of England and the south of Scotland, first by its copious clusters of white blossoms, and afterwards by its feather-tailed silky tufts attached to the fruits. Among the exotic species in greatest favour with horticulturists are *C. flammula*, which produces abundant panicles of small white flowers, and has a fine perfume; *C. cirrhosa*, remarkable for its large greenish-white flowers; and *C. viticella*, with its festooning branches adorned with pink or purple bells. *C. virginiana* is an American species, known by the same name as the English; *C. Jackmanni*, is a well-known garden hybrid. The fruit and leaves of the common clematis are acrid and vesicant.

**Clem'ens**, SAMUEL LANGHORNE, an American humorist, more generally known by his pseudonym 'Mark Twain,' born in Missouri in 1835. He worked for some time as a compositor in Philadelphia and New York, and then in 1851 learned the business of pilot on the Mississippi. Thence he went to the Nevada mines; became in 1862 local editor of a newspaper in Virginia City; went to San Francisco; was for some time a reporter, and worked in the Calaveras gold-diggings. In 1866 he went to the Sandwich Islands, and on his return com-

menced his lecturing career. He edited for a time a paper in Buffalo, and finally married and settled in Hartford, Conn. His chief books are *The Jumping Frog, &c.* (1867); *Roughing it* (1873); *The Innocents Abroad* (1869); *Tom Sawyer* (1876); *A Tramp Abroad* (1880); *The Prince and the Pauper* (1882); *Life on the Mississippi* (1883); and *Huckleberry Finn* (1885). In 1896-97, after the loss of his fortune, he made a tour of the world, giving lectures and readings, and by the results satisfied the full claims of his creditors (Feb. 7, 1898).

**Clem'ent**, properly **TITUS FLAVIUS CLEMENS**, commonly known as *Clement of Alexandria*, one of the most famous teachers of the Christian church in the 2d and at the beginning of the 3d century. He was converted from paganism to Christianity, and after travelling in Greece, Italy, and the East, became presbyter of the church of Alexandria, and teacher of the celebrated school in that city, in which place he succeeded Pantænus, his teacher, and was succeeded by Origen, his pupil. His chief remaining works are the *Protrepiticos*, *Paidagōgos*, and *Strōmateis* or *Strōmata* (Patchwork); the first an exhortation to the Greeks to turn to the one true God, the second a work on Christ, the last a collection of brief discussions in chronology, philosophy, poetry, &c. Few of the early Christians had so wide a knowledge of Greek philosophy and literature, and it is as a higher philosophic scheme that he mainly discusses Christianity. He was regarded as a saint until Benedict XIV. struck him off the calendar.

**Clement**, **CLEMENS ROMANUS**, or *Clement of Rome*, one of the 'Apostolic Fathers,' is said to have been the second or the third successor of Peter as bishop of Rome, and the first of the numerous popes named Clement. He is perhaps identical with Consul Flavius Clemens, put to death under Domitian A.D. 95. Various writings are attributed to him, but the only one that can be regarded as genuine is an Epistle to the Corinthians, first obtained in a complete form in 1875. It is of importance as exhibiting the first attempt of the Church of Rome to exercise ecclesiastical authority over other churches.

**Clément** (klā-män), **JACQUES**, the assassin of Henry III. of France, born in 1567, became a Dominican, and the fanatical tool of the Dukes of Mayenne and Aumale, and the Duchess Montpensier. Having fatally

stabbed the king, he was at once killed by the courtiers; but the populace, instigated by the priests, regarded him as a martyr; and Pope Sixtus V. even pronounced his panegyric.

**Clemen'ti**, **MUZIO**, pianist and composer, born in Rome in 1752. As early as his twelfth year he wrote a successful mass for four voices, and had made such progress in the pianoforte that an Englishman, Mr. Beckford, took him to England to complete his studies. He was then engaged as director of the orchestra of the opera in London, and his fame having rapidly increased he went in 1780 to Paris, and in 1781 to Vienna, where he played with Mozart before the emperor. In 1784 he repeated his visit to Paris, but after that remained in England till 1802, when he went back to the Continent. He returned in 1810 to England, where he settled down as superintendent of one of the principal musical establishments in London. He died in 1832, and was interred in Westminster Abbey. His most important compositions were his sixty sonatas for the pianoforte and the great collection of studies known as the *Gradus ad Parnassum*, a work of high educative value. He represented perhaps the highest point of technique of his day, and his influence upon modern execution has led to his being characterized as 'the father of pianoforte playing.'

**Cleobu'lus**, one of the *seven wise men* of ancient Greece, a native of Lindus, who travelled to Egypt to learn wisdom, and became King of Rhodes. He flourished B.C. 560.

**Cleom'enes** (-nēz), the name of three kings of Sparta, the most distinguished of whom is Cleomenes III., the last of the Heraclidæ, king from 236 to 220 B.C. He intended to reform Sparta and to restore the institutions of Lycurgus, and therefore put to death the ephori, made a new division of lands, introduced again the old Spartan system of education, made his brother his colleague, and extended the franchise. He was defeated by the allied Macedonians and Achæans at the battle of Sellasia (B.C. 222), and fled to Egypt, where he was supported by Ptolemy Euergetes, but was kept in confinement by the succeeding Ptolemy. He escaped and attempted to raise a revolt, but failing, committed suicide.

**Cle'on**, an Athenian demagogue, originally a tanner by trade. He was well known

in public before the death of Pericles, and in 427 B.C. distinguished himself by the proposal to put to death the adult males of the revolted Mytileneans and sell the women and children as slaves. In 425 he took Sphacteria from the Spartans; but in 423 and 422 he was violently attacked by Aristophanes in the Knights and in the Wasps. He was sent, however, in 422 against Brasidas, but allowed himself to be taken unawares, and was slain while attempting to flee.

**Cleopat'ra**, a Greek queen of Egypt, born B.C. 69, the eldest daughter of Ptolemy Aulētēs. When she was seventeen her father died, leaving her as joint-heir to the throne with his eldest son Ptolemy, whom she was to marry—such marriages being common among the Ptolemies. Being deprived of her part in the government (B.C. 49) she won Cæsar to her cause, and was reinstated by his influence. In a second disturbance Ptolemy lost his life, and Cæsar proclaimed Cleopatra queen of Egypt; though she was compelled to take her brother, the younger Ptolemy, then eleven years old, as husband and colleague. Cæsar continued some time at Cleopatra's court, had a son by her named Cæsarion (afterwards put to death by Augustus), and gave her a magnificent reception when she subsequently visited him at Rome. By poisoning her brother she remained sole possessor of the regal power, took the part of the triumvirs in the civil war at Rome, and after the battle of Philippi sailed to join Antony at Tarsus. Their meeting was celebrated by splendid festivals; she accompanied him to Tyre, and was followed by him on her return to Egypt. After his conquest of Armenia he again returned to her and made his three sons by her, and also Cæsarion, kings. On the commencement of the war between Augustus and Antony the latter lost a whole year in festivals and amusements with Cleopatra at Ephesus, Samos, and Athens, and when at last the fleets met at Actium, Cleopatra suddenly took to flight, with all her ships, and Antony, as if under the influence of frenzy, immediately followed her. They fled to Egypt, and declared to Augustus that if Egypt were left to Cleopatra's children they would thenceforth live in retirement. Augustus, however, demanded Antony's death and advanced on Alexandria. Believing Cleopatra, who had taken refuge in her mausoleum, to be treacherous and dead, Antony threw himself on his sword, and shortly

afterwards Cleopatra killed herself by applying an asp to her arm to escape the ignominy of being led in a Roman triumph (B.C. 30). With her the dynasty of the Ptolemies ended.

**Cleopatra's Needles**, the name given to two Egyptian obelisks, formerly at Alexandria, but one of which is now in London, the other in New York. They are made of the rose-red granite of Syene, and were originally erected by the Egyptian king Thothmes III. in front of the great temple of Heliopolis, the On of the Scriptures, where Moses was born and brought up. They were taken to Alexandria shortly before the commencement of the Christian era, and after the death of Cleopatra, but possibly in pursuance of a design originated by her. The London obelisk, which stands on the Thames Embankment, was presented to the British government in 1820, but was long left uncared for. In 1877-78, however, it was brought to London by the private munificence of Sir Erasmus Wilson, and erected in its place at a cost of some £10,000. The New York obelisk was presented to the U. States by the Khedive of Egypt, and was set up in the Central Park in 1881. Each is about 70 feet high and inscribed with numerous hieroglyphics.

**Clep'sydra**, or **WATER-CLOCK**, an ancient instrument for the measurement of time by the escape of water from a vessel through an orifice. In the older ones the hours were estimated simply by the sinking of the surface of the water, in others the water surface is connected with a dial-plate and hand by a system of weights and floats. In the accompanying figure the float A is attached to the end of a chain which is wound round the spindle B, and has at its other extremity the counter-weight C. On water being admitted from the cistern D the float rises, the counter-weight descends and turns the spindle, which again turns the hand that marks the hours.

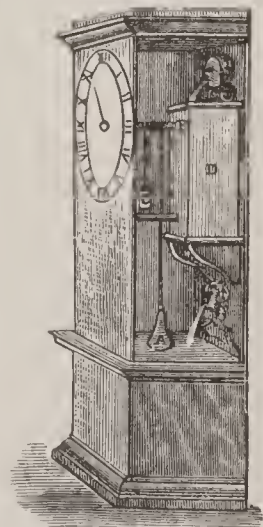

Clepsydra.

**Clere-story**, or **CLEAR-STORY**, the upper part of the nave in Gothic churches, above the triforium where a triforium is present,

and formed by walls supported on the arches of the nave, and rising above the roof of the side aisles. In these walls windows are in-

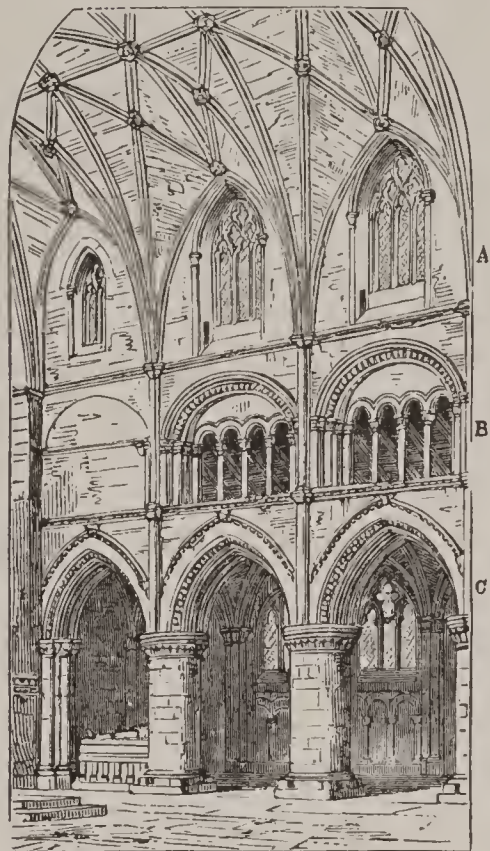

Part of Malmesbury Abbey.

A, Clear-story. B, Triforium. C, Arches of the Nave.

serted for the purpose of increasing the light in the nave.

**Clergy** (from Greek *klēros*, a lot, through the Latin *clericus* and Low Latin *clericia*), the body of ecclesiastical persons, in contradistinction to the *laity*. The Greek word came into use to indicate that this class was to be considered as the particular inheritance and property of God, or else, which is more probable, because it was customary to select by lot those set apart for special religious functions. At first there was no strongly-marked distinction between clergy and laity, but the former soon drew apart, consisting, after the apostolic age, of bishops, priests, and deacons, and in the 4th century of many additional inferior orders, such as sub-deacons, acolytes, &c. With the increased complexity of the hierarchy there was a steady accretion of privileges until the burden of these became intolerable to the laity. In England few of these now remain, the clergy being generally regarded as invested with no inherent claim to regard. A clergyman can not, however, be compelled to serve as jurymen, he is exempted from arrest while cele-

brating divine worship, from acting as bailiff, constable, or like office, from attendance at a court leet; but on the other hand he cannot accept a seat in the House of Commons, engage in trade, or farm lands of more than eighty acres without his bishop's consent. The Episcopalians recognize three classes of clergy—bishops, priests, and deacons; and generally hold the doctrine of the apostolic succession. Large numbers of Protestants however, reject this dogma, and believe in the ministry of only one order. The Catholic clergyman, according to the doctrine of the Roman Catholic Church, is endowed in his spiritual character with a supernatural power, which distinguishes him essentially from the layman. *Regular* clergy are those who live according to monastic rule, *secular* clergy those who do not.

**Clergy, BENEFIT OF.** See *Benefit of Clergy*.

**Clerk, JOHN**, of Eldin, near Edinburgh, born 1728, died 1812, a naval tactician, for whom is claimed the invention of the manœuvre of *breaking the enemy's line*, put forth in an *Essay on Naval Tactics* published in 1790, afterwards employed with signal effect by Howe, St. Vincent, Duncan, and Nelson. His son John, Lord Eldin, born 1757, died 1832, was a distinguished Scottish judge.

**Clerk, PARISH**, a lay officer of the Church of England, appointed either by the incumbent or the parishioners. It is his duty to lead the responses and assist in public worship, at funerals, &c.

**Clerk of the House of Commons**, an officer appointed by the crown, whose duty it is to make minutes of the decisions of the house (not of the debates); to see that these minutes are correctly printed and handed to the members; to read aloud all such papers as the house may order to be read; and to perform the office of president (without taking the chair) during the choice of a speaker.

**Clerks to the Signet.** See *Writers to the Signet*.

**Clermont-de-Lodève** (klār-mōŋ-d-lo-dāv), or *Clermont de l'Hérault* (-d-lā-rō), a town of France, dep. of Hérault, 23 miles west by north of Montpellier. Pop. 5191.

**Clermont-en-Beauvaisis** (klār-mōŋ-tāŋ-bō-vā-sē), or *Clermont de l'Oise* (d-lwäs), a town of France, dep. Oise, 17 miles east by south Beauvais. Pop. 5529.

**Clermont-Ferrand** (klār mōŋ-fā-rāŋ), a town of France, capital of department Puy-de-Dôme, on a hill at the foot of the volcanic

range in which the summit of the Puy is conspicuous. It possessed considerable importance under the Romans, and became a bishop's see at a very early period. It is an antique and gloomy town built of dark volcanic stone. The most remarkable edifices are the cathedral, a huge, irregular, gloomy pile, and the Church of Notre Dame, founded in 580. Pop. 1891, 50,119.

**Clermont-Tonnerre** (klār-mōŋ-ton-nār), the name of a noble French family of whom one of the most celebrated was Count Stanislas, born in 1747. At the breaking out of the revolution of 1789 he endeavoured to promote the establishment of a constitutional monarchy, founding with Malouet the Monarchical Club, and with Fontanes the Journal des Impartiaux. In 1791 he was charged with assisting the king in his attempt to escape, but was set free on swearing fidelity to the assembly. In 1792, however, he was murdered by the mob at the house of the Countess de Brissac.

**Cleveland**, a district in the N. Riding of Yorkshire, about 28 miles long and 15 broad, between the Tees and the coast at Whitby, also a parl. div. of the county. It has extensive deposits of iron ore, which is smelted chiefly at Middlesbrough.

**Cleveland**, a city of the U. States, the second of Ohio in population, capital of Cuyahoga county, on the south shore of Lake Erie, 255 miles north-east from Cincinnati. It is divided into two parts by the river Cuyahoga, and is beautifully situated, chiefly on an elevated plain above the lake, and for the most part handsomely laid out with streets crossing each other at right angles. The abundance of trees gives it the name of 'The Forest City.' The Cuyahoga is spanned by several bridges, and in particular by the Viaduct, an elevated street and bridge erected at great expense. Among the buildings are the U. States building, City Hall, Case Hall, Medical College, railway depôt, &c. Cleveland is an important railway centre, has an excellent harbour and extensive lake traffic, and large manufactures, especially in iron and steel; petroleum-refining and pork-packing being also important industries. There is a harbour of refuge constructed by government. Pop. 1890, 261,353.

**Cleveland**, STEPHEN GROVER, 22d president of the U. States, born at Caldwell, N. J., March 18, 1837. He settled in Buffalo, and having acquired an excellent position as a lawyer was elected mayor in

1881. Next year he was elected by the democrats governor of New York State, and in 1884, having been nominated for the presidency by the democratic national convention at Chicago, was elected on Nov. 4. Civil service reform and tariff reform were advocated by him during his tenure of office, which came to an end in 1889. In 1892 he was again placed in nomination for the presidency by the Democratic party and was elected. He married at the White House, June 2, 1886, Miss Frances Folsom. He now resides at Princeton, N. J.

**Cleves** (klēvz; in German *Kleve*), formerly the capital of the dukedom of Cleves, a town in Rhenish Prussia, 70 miles n.w. of Cologne, about a league from the Rhine, with which it is connected by a canal. It has manufactures of tobacco, leather, and cottons, and a mineral spring with baths, &c. Pop. 10,170.

**Clew Bay**, a bay on the west coast of Ireland, co. Mayo, containing a vast number of islets, many of them fertile and cultivated.

**Cliché** (klē-shā), an electrotype or a stereotype cast from an engraving, especially from a woodcut.

**Clichy** (klē-shē), a town about 4 miles n.w. of Paris, of which it now forms a suburb. Pop. 26,741.

**Click-beetle.** See *Elater*.

**Cli'ents**, in ancient Rome, were citizens of the lower ranks who chose a patron from the higher classes, whose duty it was to advise and assist them, particularly in legal cases, and in general to protect them. The clients, on the other hand, were obliged to portion the daughters of the patron if he had not sufficient fortune; to follow him to the wars; to vote for him if he was candidate for an office, &c. This relation continued till the time of the emperors.

**Clifford**, the name of a very old English family, several members of which have played an important part in history. The founder of the family, WALTER, son of Richard Fitz-Ponce, a Norman baron, acquired the castle of Clifford, in Herefordshire, under Henry II., and hence took the name of Clifford. In 1523 the Cliffords became Earls of Cumberland, but in 1643 this title became extinct. The male line of the Cliffords is at present represented by the baronial family Clifford of Chudleigh. The first Baron Clifford of Chudleigh was THOMAS CLIFFORD, one of the members of the Cabal (which see), who was raised to this dignity in 1672.

**Clifford**, WILLIAM KINGDON, English mathematician, born in 1845; educated at King's College, London, and at Trinity College, Cambridge, where he graduated as second wrangler. In 1871 he was appointed professor of applied mathematics at University College, London. In 1876 his health gave way, but was restored by a summer spent in Spain and Algiers, though not permanently, for two years later he again broke down, and died soon afterwards at Madeira, March 3, 1879. In mathematics his teaching and writings are regarded as marking an epoch in the history of the science in England. His Canonical Dissection of a Riemann's Surface and his theory of Biquaternions, are well-known works.

**Clifton**, a hamlet on the southern bank of the river Trent, near Nottingham, England. A handsome grove of trees, made famous by Henry Kirke White, overlooks the river.

**Clifton**, a handsome residential suburb of Bristol, England. A suspension-bridge here crosses the river Avon 245 feet above its bed, uniting the counties of Gloucester and Somerset. There is here a tepid mineral spring which formerly attracted visitors.

**Climac'teric** (*annus climactericus*), according to an old theory, a critical period in human life in which some great alteration is supposed to take place in the constitution. The first climacteric is, according to some, the seventh year; the others are multiples of the first, as 14, 21, &c.; 63 is called the grand climacteric.

**Climate**, the character of the weather or atmospheric phenomena peculiar to every country as respects heat and cold, humidity and dryness, the direction and force of the prevailing winds, the alternation of the seasons, &c., especially as such conditions affect animal and vegetable life. In general, geographical latitude is the principal circumstance to be taken into view in considering the climate of a country, and thus the torrid, temperate, and frigid zones may each be said roughly to have a climate of its own. The highest degree of heat is found in the equatorial regions, and the lowest, or the greatest degree of cold, at the poles. In the former the temperature continues practically the same all the year round, though there may be alternating rainy seasons and dry seasons. The variations in temperature are very considerable in the temperate zones, and increase as we approach the polar circles. The heat of the higher latitudes, especially about 59° or

60°, is, in July, greater than that of countries 10° nearer the equator, and at Tornea, in Lapland, where the sun's rays are very oblique even in summer, the heat is sometimes equal to that of the torrid zone, because the sun is almost always above the horizon. But even in the equatorial regions, and still more in intermediate regions, the temperature is affected by local configuration and circumstances. In the deserts of Africa, for instance, owing to the exceptional radiating power of sandy plains and the absence of aqueous vapour in the atmosphere, the heat is excessive, while in the corresponding latitudes of South America the mountainous character of the country makes the climate more moderate. Altitude above the sea indeed has everywhere the same effect as removal to a greater distance from the equator, and thus in the Andes we may have a tropical climate at the sea-level and an arctic one on the mountain summits. The winds to which a country is most exposed by its situation have also a great influence on the climate. In the northern hemisphere if north and east winds blow frequently in any region it will be colder, the latitude being the same, than another which is often swept by milder breezes from the south and west. The climate of Southern Europe, for instance, is decidedly affected by the warm south winds which blow from the hot deserts of Africa. The greater or lesser extent of coast-line a country possesses in proportion to its area has a decided influence on the climate. The almost unvarying temperature of the ocean equalizes in some degree the periodic distribution of heat among the different seasons of the year, and the proximity of a great mass of water moderates, by its action on the atmosphere, the heat of summer and the cold of winter. Hence the more equable temperature of islands and coasts as compared with that of places far inland, and hence the terms *insular climate* and *continental climate*. The British Isles, Tasmania, and New Zealand enjoy a mild or insular climate as compared with, say, Central Russia or Central Asia. Thus it happens that London has a milder winter and a cooler summer than Paris, though the latter is nearly 3° farther south. Similarly, though Warsaw and Amsterdam are almost in the same latitude, the mean annual temperature of the former is 46·48°, while it reaches at the latter 53·4° Fahr. The proximity of large masses of water involves also the presence of much aqueous

vapour in the atmosphere, which may be condensed in abundant rains so as to greatly influence the plant-life of a country. Direction of mountain chains, set of ocean currents, nature of soil, are other modifying elements. In exhibiting graphically the chief climatic facts of a region various methods may be adopted, but in all the use of *isothermal lines* is one of the most instructive features. These are lines drawn on a map or chart connecting those places which have the same mean annual temperature or same mean summer and mean winter temperature. In this way we may divide the earth into zones of temperature which by no means coincide with the limits of the zones into which the earth is astronomically divided, and when compared with these on a map show interesting and instructive divergences. Geology teaches that vast changes have taken place in the climate of most if not of all countries, the causes of which are not fully understood.

**Cli'max** (Greek, *klimax*, a ladder or stairs), a rhetorical figure in which a series of propositions or objects are presented in such a way that the least impressive comes first, and there is a regular gradation from this to the most impressive or final.

**Climbers**, a name applied to birds of the order Scansores from their climbing habits. They have two toes before and two behind, and are represented by parrots, cockatoos, &c.

**Climbing Perch** (*Anabas scandens*), a singular fish, type of the family Anabasidæ, remarkable for having the pharyngeal bones



Climbing Perch (*Anabas scandens*).

enlarged and modified into a series of cells and duplications so that they can retain sufficient water to keep the gills moist and enable the fish to live out of water six days. The climbing perch of India proceeds long distances overland in search of water when the pools in which it has been living have dried up. It is also credited with a power of climbing the rough stems of palm-trees, but as to this latter point authorities disagree.

**Climbing Plants** are plants of weak stems which naturally seek support from their surroundings to rise from the ground. Some

are twining plants, rising by winding themselves or their tendrils (*cirri*) round the trunks of trees, &c. Such are the honeysuckle and scarlet-runner. Others, like the ivy, attach themselves by small roots developed from the stem as they ascend. Some in climbing always twine spirally from right to left, others again always take the opposite direction.

**Clincher-built**, **CLINKER-BUILT**, a term in ship-building when the planks are so arranged that the lower edge of the plank above overlies the edge of that below it.

**Clin'ical Medicine** (from the Greek *klinē*, a bed), that department of medicine which teaches how to investigate, at the bedside of the sick, the nature of diseases, to note their course and termination, and to study the effects of the various modes of treatment to which they are subjected. A *clinical lecture* is the instruction which the teacher gives his pupil at the bedside of the patient.

**Clinton**, DE WITT, born in Orange Co., N. Y., 1769, died 1828, eminent as a lawyer, statesman, and organizer of the Erie Canal; was Governor of State of New York.

**Clinton**, Worcester Co., Mass., 45 miles N. W. of Boston; has 6 churches, a bank, manufactures of carpets, gingham cloths and wire cloth. Pop. 1890, 10,424.

**Clinton**, city; capital of Clinton co., Ia., on the Mississippi river; 42 miles above Davenport, and 138 miles by railroad W. of Chicago. The river is crossed by an iron bridge, about 4000 feet long and costing \$600,000. The cars of three lines of railroads pass over the bridge, making the city a considerable railroad centre. It contains large repair shops, foundries, sash and blind factories, sawmills, etc. Pop. (1895) 17,375.

**Clinton**, SIR HENRY, a British general who served in the Hanoverian war, and was sent to America in 1775 with the rank of major-general, where he distinguished himself in the battle of Bunker Hill. He died in 1795.

**Cli'o**, a genus of pteropodous molluscs of which one species, *C. borealis*, is extremely abundant in the northern seas, constituting the principal part of the food of the whale, and hence often called *whale's food*.

**Clipper**, a modern build of sailing ship, having a long sharp bow, the greatest beam abaft the centre, and a great rate of speed.

**Clith'eroe**, a municipal borough, England, county Lancaster, 28 miles N.N.W. of Man-

chester, giving name to a parl. div. of the county. It is the seat of some large cotton spinning and weaving establishments, paper manufactories, foundries, and large print-works. Pop. 1891, 10,815.

**Clito'ria**, a genus of tropical leguminous plants, mostly climbers, one of which, *C. Ternatea*, with beautiful blue flowers, has long been grown in England.

**Cli'tus**, the foster-brother of Alexander the Great. He saved Alexander's life at the Granicus, but was afterwards slain by him in a fit of intoxication, an act for which Alexander always showed the bitterest remorse.

**Clive**, ROBERT, Lord Clive and Baron of Plassey, English general and statesman, was born in 1725 in Shropshire. In his nineteenth year he entered the East India Company's service at Madras as a writer, but in 1747 quitted the civil for the military service. It was a perilous time for British interests in India. The French under Dupleix had gained important privileges and large grants of territory, and in alliance with Chunda Sahib, nabob of Arcot, were threatening the very existence of the British establishments. In 1751 Clive, who had already a reputation for skill and courage, marched on the large city of Arcot with 200 British troops and 300 Sepoys, and took it, although strongly garrisoned, without a blow, withstood a siege by Chunda Sahib for nearly two months, and at last routed the enemy, took possession of important posts, and returned to Madras completely victorious. In 1753 he sailed to England to recover his health, and was received with much honour. Two years later he was back in India, in his governorship of St. David's, from which he was soon summoned to command the expedition sent to Bengal, where the nabob Suraj-ud-Dowlah had attacked the British, destroyed their factories, taken Calcutta, and suffocated over 120 of his prisoners in the Black Hole. Clive soon took possession of Calcutta and brought Suraj-ud-Dowlah to terms, but having no trust in the loyal intentions of the nabob he resolved to dethrone him. With the help of Meer Jaffier, one of the nabob's officers, he effected his purpose, and in the battle of Plassey completely overthrew Suraj-ud-Dowlah's forces. Meer Jaffier now became the new nabob, and Clive was made governor of Calcutta. Here he was equally successful against the encroachments of the Dutch, defeating their forces both by sea and land, Clive now

visited England again, where his success was highly applauded without much inquiry as to the means; and in 1761 he was raised to the Irish peerage with the title of Lord Clive, Baron of Plassey. In 1764 fresh



Lord Clive.

troubles in India brought him back, but now as president of Bengal, with command of the troops there. Before his arrival, however, Major Adams had already defeated the Nabob of Oude, and Lord Clive had only the arranging of the treaty by which the Company obtained the disposal of all the revenues of Bengal, Bahar, and Orissa. In 1767 he finally returned to England. In 1773 a motion supported by the minister was made in the House of Commons, that 'Lord Clive had abused the powers with which he was intrusted;' but it was rejected for a resolution that 'Lord Clive had rendered great and meritorious services to his country.' His health was by this time broken, and in one of his habitual fits of melancholy he put an end to his life, November 22, 1774. Clive was of a reserved temper, although among his intimate friends he could be lively and pleasant. He was always self-directed and secret in his decisions, but inspired those under his command with the utmost confidence, owing to his bravery and presence of mind. In private life he was kind and exceedingly liberal. He married the sister of the astronomer-royal Dr. Maskelyne, by whom he had two sons and three daughters.

**Cliv'ers.** See *Cleavers*.

**Cloa'ca**, an underground conduit for drainage, of which the oldest known example



## CLOCK.

is the *Cloaca Maxima*, or great sewer at Rome, built some 2500 years ago. A portion of it is still standing. It is about 13 feet high and as many wide.—The term is also applied to the excrementory cavity in birds, reptiles, many fishes and lower mammalia (Monotremata), formed by the extremity of the intestinal canal, and conveying outwards the fæces, urine, &c.

**Clock**, an instrument for measuring time and indicating hours, minutes, and usually seconds, by means of hands moving on a dial-plate, and differing from a watch mainly in having the movement of its machinery

regulated by a pendulum, and in not being portable.

The largest and most typical clocks also differ in having their machinery set in motion by means of a falling weight or weights, the watch wheel-work being moved by the force of an uncoiling spring; but many clocks also have a spring setting their works in motion. The use of a *horologium*, or hour-teller, was common even amongst the ancients, but their time-pieces were nothing else than

sun-dials, hour-glasses, and clepsydræ. In the earlier half of our era we have accounts of several attempts at clock construction: that of Boethius in the 6th century, the clock sent by Harun al Rashid to Charlemagne in 809, that made by Pacificus, archdeacon of Verona, in the 9th century, and that of Pope Sylvester II. in the 10th century. It is doubtful, however, if any of these was a wheel-and-weight clock, and it is probably to the monks that we owe the invention of clocks set in motion by wheels and weights. In the 12th century clocks were made use of in the monasteries, which announced the end of every hour by the sound of a bell put in motion by means of wheels. From this time forward the expression, 'the clock has struck,' is often met

with. The hand for marking the time is also made mention of. In the 14th century there are stronger traces of the present system of clock-work. Dante particularly mentions clocks. Richard, abbot of St. Albans in England, made a clock in 1326, such as had never been heard of till then. It not only indicated the course of the sun and moon, but also the ebb and flood tide. Large clocks on steeples likewise were first made use of in the 14th century. Watches are a much later invention, although they have likewise been said to have been invented as early as the 14th century. A celebrated clock, the construction of which is well known, was set up in Paris for Charles V. in 1379, the maker being Henry de Vick, a German. It probably formed a model on which clocks were constructed for nearly 300 years, and until Huyghens applied the pendulum to clock-work as the regulating power, about 1657. The great advantage of the pendulum is that the beats or oscillations of a pendulum all occupy substantially the same time (the time depending on its length), hence its utility in imparting regularity to a time-measurer. The mechanism by which comparative regularity was previously attained, though ingenious and simple, was far less perfect; and the first pendulum *escapement*, that is, the contrivance by which the pendulum was connected with the clock-work, was also less perfect than others subsequently introduced, especially Graham's *dead-beat* escapement, invented in 1700. (See *Escapement*.) In a watch the balance-wheel and spring serves the same purpose as the pendulum, and the honour of being the inventor of the balance-spring was contested between Huyghens and the English philosopher Dr. Hooke. Various improvements followed, such as the chronometer escapement, and the addition of a compensation adjustment, by which two metals having unequal rates of expansion and contraction under variations of temperature are combined in the pendulum or the balance-wheel, so that, each metal counteracting the other, the vibrations are isochronous under any change of temperature. This arrangement was perfected by Harrison in 1726, and is especially useful in navigation. The accompanying cut shows the going part of a clock in its simplest form. A is a drum on which is wound the cord P, to which the weight is attached, the drum having a projecting axis with a square end to receive the key in

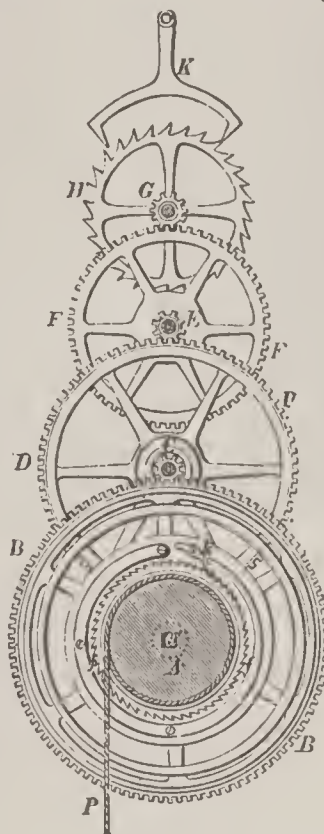

Clock-work.

winding up the clock. The drum is connected with B, the first wheel of the train, by means of the ratchet-wheel F, and catch R, which allow the clock to be wound up without turning B. The wheel B drives the pinion C and the wheel D, the latter called the minute wheel; and there is a similar connection between D, E, F, G, and H. The last is named the escapement wheel, and into its teeth work the pallets of the anchor K, which swings backward and forward with the pendulum. The wheel D turns once in an hour, the wheel H 60 times (the pendulum marking seconds), and by means of other wheels, and one axis working inside another, the clock hands and dial show hours, minutes, and seconds. The striking machinery of a clock, or that by which hours, quarters, &c., are sounded, is no necessary part of a clock, and forms indeed a separate portion of the works, usually driven by a separate falling weight, and coming into play at certain times, when there is a temporary connection between the two portions of the clock machinery. See also *Watch*.

**Clo'dius Pulcher**, PUBLIUS, a notorious public character of ancient Rome, son of Appius Claudius Pulcher, who was consul about 79 B.C. He served in the third Mithridatic war under Sullus, and filled different high posts in the provinces of the East, where his turbulence was the cause of serious disturbances. Returning to Rome, he became a popular demagogue, was elected tribune in 59 B.C., was the means of procuring Cicero's banishment, and continued to be a ringleader in all the seditions of the time till killed in an encounter between his followers and those of Titus Annius Milo. One of Cicero's orations was written in defence of Milo.

**Clog-almanac**, an almanac or calendar made by cutting notches or characters on a *clog* or block, generally of wood. The block had generally four sides, three months for each edge. The number of days is marked by notches, while various symbols are used

to denote saints' days, the golden number, &c.

**Clogher** (klō'gèr), a village and old episcopal see of Ireland in county Tyrone, with cathedral and bishop's palace. The see, of which St. Patrick is said to have been the first bishop, is united with that of Armagh. Pop. 225.

**Cloisonné** (klwà-son-ā). See *Enamel*.

**Clois'ter**, an arched way or gallery, often forming part of certain portions of monastic and collegiate buildings, usually having a wall of the building on one side, and an open colonnade, or a series of windows with piers and columns adjoining an interior yard or court on the other side. Such galleries were originally intended as places of exercise and recreation, the persons using them being under cover. The term is also used as equivalent to convent or monastery.



Part of the Cloister, Westminster Abbey.

**Clonakil'ty**, a seaport of Ireland, co. Cork, with a considerable trade in grain. Pop. 3676.

**Clonmel'**, a municipal and, until 1885, parliamentary borough of Ireland, partly in county Waterford and partly in county Tipperary. It lies in a beautiful valley on both sides of, and on two islands in, the river Suir, and has a jail, barracks, court-house, &c.; carries on tanning, brewing, and flour-milling, and has a trade in agricultural produce. Pop. 9325.

**Clontarf'**, a town of Ireland, county Dublin, on the northern shore of Dublin Bay. It is a much-frequented watering-place and is historically interesting as the scene of Brian Boromhe's victory over the Danes in 1014. Pop. 1891, 5105.

**Cloots** (klōts), JEAN BAPTISTE, BARON, a singular character well known during the revolutionary scenes in France under the appellation of *Anacharsis Cloots*. He was born at Cleves in 1755, and was brought up at Paris. He became possessed of a considerable fortune, which he partly dissipated in fantastic schemes for the union of all peoples and races in one democratic brotherhood. The outbreak of the French revolu-

tion afforded him the kind of career he sought. In 1790, Cloots presented himself at the bar of the national assembly, accompanied by a considerable number of enthusiastic followers of various nationalities, English, German, Italian, Spanish, Arabians—or Parisians dressed up as such. He described himself as the orator of the human race, and demanded the right of confederation, which was granted him. His enthusiasm for radical reforms, his hate of Christianity and of royalty, and a gift of 12,000 livres on behalf of the national defence, gained him in Sept. 1792 election to the national convention, in which he voted for the death of Louis XVI. in the name of the human race. But becoming an object of suspicion to Robespierre, he was arrested and guillotined 24th March, 1794. He met his fate with great indifference.

**Close Borough**, a borough the right of nominating a member of parliament for which was in the hands of a single person.

**Close Corporation**, a corporation which fills up its own vacancies, the election of members not being open to the public.

**Close-hauled**, in navigation, said of a ship when the general arrangement or trim of the sails is such as to enable her to sail as nearly against the wind as possible.

**Clo'sure**, a rule in British parliamentary procedure adopted in 1887 by which, at any time after a question has been proposed, a motion may be made with the speaker's or chairman's consent 'That the question be now put,' when the motion is immediately put and decided without debate or amendment. So also if a clause of a bill is under debate a motion that it stand or be added may be put and carried in the same way. The motion must be supported by more than 100 members and opposed by less than 40, or have the support of 200 members. The introduction of the closure was intended to prevent debates from being too much spun out.

**Cloth**, a fabric formed by interweaving threads or fibres of animal or vegetable origin, as wool, hair, cotton, flax, hemp, &c. Cloth may also be made by *felting* as well as by weaving. See *Cotton, Woollen, Silk, &c.*

**Clothes-moth**, the name common to several moths of the genus *Tinæa*, whose larvæ are destructive to woollen fabrics, feathers, furs, &c., upon which they feed, using at the same time the material for the construction of the cases in which they assume the chrysalis state.

**Clothing**, the clothes or dress, that is the artificial coverings collectively, which people wear. Nothing is more necessary to comfort than that the body should be kept in nearly a uniform temperature, thus preventing the disturbance of the important excretory functions of the skin by the influence of heat or cold. Hence in a changeable climate the question of clothing becomes of special importance. The chief end proposed by clothing ought to be protection from the cold. A degree of cold amounting to shivering cannot be felt without injury to the health, and the strongest constitution cannot resist the benumbing influence of a sensation of cold constantly present, even though it be so moderate as not to occasion immediate complaint, or to induce the sufferer to seek protection from it. This degree of cold often lays the foundation of the whole host of chronic diseases, foremost amongst which are found scrofula and consumption. The only kind of dress that can afford the protection required by the changes of temperature to which the cooler or temperate climates are liable, is *woollen*. Those who would receive the advantage which the wearing of woollen is capable of affording, must wear it next the skin; for it is in this situation only that its health-preserving power can be felt. The great advantages of woollen cloth are briefly these:—the readiness with which it allows the escape of sweat through its texture; its power of preserving the sensation of warmth to the skin under all circumstances; the slowness with which it conducts heat; the softness, lightness, and pliancy of its texture. *Cotton cloth*, though it differs but little from linen, approaches nearer to the nature of woollen, and on that account must be esteemed as the next best substance of which clothing may be made. *Silk* is the next in point of excellence, but it is very inferior to cotton in every respect. *Linen* possesses the contrary of most of the properties enumerated as excellencies in woollen. It retains the matter of perspiration in its texture, and speedily becomes imbued with it; it gives an unpleasant sensation of cold to the skin; it is very readily saturated with moisture, and it conducts heat too rapidly. Clothes should be so made as to allow the body the full exercise of all its motions. The neglect of this precaution is productive of more mischief than is generally believed, and the misery and suffering arising from it often begin while we are yet in the cradle.

**Clo'tho**, in Greek mythology, that one of the three Fates or Parcae whose duty it was to put the wool for the thread of life round the spindle, while that of Lachęsis was to spin it, and that of Atrępos to cut it when the time had come.

**Cloud**, a collection of visible vapour or watery particles suspended in the atmosphere at some altitude. They differ from fogs only by their height and less degree of

transparency. The average height of clouds is calculated to be  $2\frac{1}{2}$  miles, thin and light clouds being much higher than the highest mountains, while thick heavy clouds often touch low mountains, steeples, and even trees. Clouds differ much in form and character, but are generally classed (following Luke Howard, in his Essay on Clouds) into three simple or primary forms, viz.:—1. The *cirrus*, so called from its resemblance to a lock

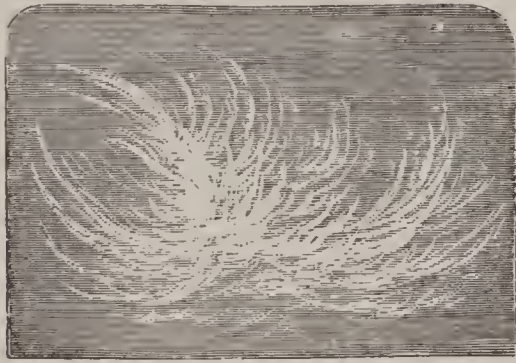

Cloud—Cirrus.



Cloud—Cumulus.



Cloud—Stratus.



Cloud—Nimbus.

of hair, and consisting of fibres which diverge in all directions. Clouds of this description float at a great height, usually from 3 to 5 miles above the earth's surface. 2. The *cumulus* or *heap*, a cloud which assumes the form of dense convex or conical heaps, resting on a flattish base, called also summer-cloud. Under ordinary circumstances these clouds accompany fine weather, especially in the heat of summer. They attain their greatest size early in the afternoon and gradually decrease towards sunset. 3. The *stratus*, so named from its spreading out uniformly in a horizontal layer, which receives all its augmentations of volume from below. It belongs essentially to the night, and is frequently seen on calm summer evenings after sunset ascending from the lower to the higher grounds, and dispersing in the form of a cumulus at sunrise. These three primary forms of clouds are subdivided as follows:—1. The *cirro-cumulus*, com-

posed of a collection of cirri, and spreading itself frequently over the sky in the form of beds of delicate snow-flakes. 2. The *cirro-stratus* or *wane-cloud*, so called from its being generally seen slowly sinking, and in a state of transformation; when seen in the distance, a collection of these clouds suggests the resemblance of a shoal of fish, and the sky, when thickly mottled with them, is called in popular language a *mackerel sky*. 3. The *cumulo stratus* or *twain-cloud*, one of the grandest and most beautiful of clouds, and consisting of a collection of large fleecy clouds overhanging a flat stratum or base. 4. The *nimbus, cumulo-cirro-stratus*, or *rain-cloud*, recognizable, according to Mr. Howard, by its fibrous border and uniformly gray aspect. It is a dense cloud spreading out into a crown of cirrus and passing beneath into a shower. It presents one of the least attractive appearances among clouds, but it is only when the dark surface of this

cloud forms its background that the splendid phenomenon of the rainbow is exhibited in perfection.

**Cloud** (klö), ST., a town, France, department Seine-et-Oise, 6 miles s.w. from Paris, charmingly situated on the slope of a hill overlooking the river Seine. It is celebrated for its château and its magnificent park, a favourite holiday resort of the Parisians. As the residence of the monarchs of France, St. Cloud is historically interesting. Louis XIV. bought the old château and presented it to his brother, the Duke of Orleans, who enlarged and transformed it into a splendid palace, which became the residence of Henrietta, queen of Charles I. of England, during her exile. It was sold by Louis-Philippe of Orleans to Marie-Antoinette, and after the revolution chosen by Napoleon for his residence. It was the summer residence of Napoleon III., and was greatly damaged in the Franco-German war. Pop. 4747.

**Cloudberry**, or MOUNTAIN BRAMBLE (*Rubus chamaemorus*), a fruit found plentifully in the north of Europe, Asia, and America, and common in some of the more elevated moors of Britain, of the same genus with the bramble or blackberry. The plant is from 4 to 8 or 10 inches high, with a rather large handsome leaf, indented and serrated at the edges. The flowers are large and white, and the berries, which have a very fine flavour, are orange-yellow in colour, and about the size of a bramble-berry.

**Clough** (kluff), ARTHUR HUGH, English poet, born at Liverpool 1st January, 1819. He studied under Dr. Arnold at Rugby, and then at Oxford, where he highly distinguished himself. On his return from a tour in America (1852) he was appointed an examiner attached to the educational branch of the privy-council office. He died 13th November, 1861, at Florence, while returning from a journey to Greece. His poems, of which the best known are *Bothie of Tober-na-Vuolich*, *Amours de Voyages*, and the *Tragedy of Dipsychus*, were published, along with a memoir, by Mr. F. T. Palgrave, in 1862.

**Clove Bark**, or CULILAWAN BARK, is furnished by a tree of the Molucca Islands (*Cinnamomum Culilawan*). It is in pieces more or less long, almost flat, thick, fibrous, covered with a white epidermis of a reddish-yellow inside, of a nutmeg and clove odour, and of an aromatic and sharp taste. In commerce the name is also given to the bark of the *Myrtus caryophyllata*. It is of

a deep brown colour, very thin and hard, and has similar properties to cinnamon.

**Clove-gillyflower**, the carnation, or a clove-scented variety of it.

**Clover**, or TREFOIL, a name of different species of plants of the genus *Trifolium*, nat. order Leguminosæ. There are about 150 species, of which 18 are natives of Britain. Some are weeds, but many species are valued as food for cattle. *T. pratense*, or common red clover, is a biennial, and sometimes, especially on chalky soils, a triennial plant. This is the kind most commonly cultivated, as it yields a larger product than any of the other sorts. *Trifolium repens*, or white clover, is a most valuable plant for pasturage over the whole of Europe, Central Asia, and North America, and has also been introduced into South America. The bee gathers much of its honey from the flowers of this species. *T. hybridum*, Alsike, hybrid, or Swedish clover, has been long cultivated in the south of Sweden, and for some time also in other countries; it is strongly recommended for cold, moist, stiff soils. It resembles the common red clover in duration, stature, and mode of growth. *T. medium*, perennial red or meadow clover, much resembles the common red, but differs somewhat in habit, and the bright red flowers are larger and form a less compact head. Its produce is less in quantity, and not so nutritive, as that of the common red. The name clover is often applied to plants like medick and melilot, cultivated for the same purpose and belonging to the same natural order, although not of the same genus.

**Clover-weevil**, a kind of weevil, genus *Apion*, different species of which, or their larvæ, feed on the leaves and seeds of the clover, as also on tares and other leguminous plants. *A. apricans*, of a bluish-black colour, and little more than a line in length, is especially destructive.

**Cloves**, a very pungent aromatic spice, the dried flower-buds of *Caryophyllus aromaticus*, a native of the Molucca Islands, belonging to the myrtle tribe, now cultivated in Sumatra, Mauritius, Malacca, Jamaica, &c. The tree is a handsome evergreen from 15 to 30 feet high, with large elliptic smooth leaves and numerous purplish flowers on jointed stalks. Every part of the plant abounds in the volatile oil for which the flower-buds are prized. The spice yields a very fragrant odour, and has a bitterish, pungent, and warm taste. It

is sometimes employed as a hot and stimulating medicine, but is more frequently used in culinary preparations.



Clove (*Caryophyllus aromaticus*).

**Clovis** (from old Ger. *Chlodwig*, mod. Ger. *Ludwig*, Fr. *Louis*) King of the Franks, born 465, succeeded his father Childeric in the year 481, as chief of the warlike tribe of Salian Franks, who inhabited Northern Gaul. In 486 he overthrew the Roman governor at Soissons and occupied the country between the Somme and the Loire. The influence of his wife Clotilda, a Burgundian princess, at length converted him to Christianity, and on Dec. 25, 496, he was baptized with several thousands of his Franks at Rheims, and was saluted by Pope Anastasius as 'most Christian king,' he being orthodox, while most of the western princes were Arians. It now became his object to rid himself by all means of all the other Frankish rulers, in order that he might leave the whole territory of the Franks to his children; and in this purpose he succeeded by treachery and cruelty. He died at Paris, which he had made his capital, on Nov. 27, 511, in the thirtieth year of his reign. In the last year of his reign Clovis had called a council at Orleans, from which are dated the peculiar privileges claimed by the kings of France in opposition to the pope.

**Clown**, the buffoon or practical jester in pantomime and circus performances. On the old English stage the clown was the privileged laughter-provoker, who, without taking any part in the dramatic development of the piece represented, carried on his improvised jokes and tricks with the actors, often indeed addressing himself directly to the audience instead of confining himself to what was going on on the stage. In Shakespeare's dramas, a distinct part is assigned to the clown, who no longer appears

as an extempore jester, although the part he plays is to a certain extent in keeping with his traditional functions. He is now confined to the pantomime and the circus, in the former of which he plays a part allied to that of the French *Pierrot*.

**Cloyne**, a town in Ireland, 16 miles E. by S. of Cork, the seat of a Roman Catholic bishop. From 1638 to 1833 it was the see of a bishop of the Established Church, but in the latter year it was united with Cork and Ross. Pop. 1126.

**Club**, a select number of persons in the habit of meeting for the promotion of some common object, as social intercourse, literature, politics, &c. It is a peculiarly English institution, which can scarcely be said to have taken root in any other country except America. The coffee-houses of the 17th and 18th centuries are the best representatives of what is meant by a modern club, while the clubs of that time were commonly nothing but a kind of restaurants or taverns where people resorted to take their meals. But while anybody was free to enter a coffee-house, it was absolutely necessary that a person should have been formerly received as a member of a club, according to its regulations, before he was at liberty to enter it. Among the earliest of the London clubs was the Kit-cat Club, formed in the reign of Queen Anne, among whose forty members were dukes, earls, and the leading authors of the day. Another club formed about the same time was the Beefsteak Club. Originally these two clubs had no pronounced political views, but in the end they began to occupy themselves with politics, the Kit-cat Club being Whig, and the Beefsteak Club Tory. Perhaps the most celebrated club of last century was that which was first called *The Club par excellence*, and numbered among its members Dr. Johnson, Sir Joshua Reynolds, Edmund Burke, Oliver Goldsmith, Edward Gibbon, and others. The most important London political clubs of the present day are the Carlton Club, a sort of headquarters for the Conservative party, and the Reform Club, the building belonging to which stands next to that of the Carlton Club, the great club of the Liberal party. Similar clubs exist also in Edinburgh, Glasgow, and other cities of the kingdom. Some of the London clubs are for ladies as well as gentlemen, and one or two for ladies alone. Clubs are often provided with reading-room and library, smoking-room, billiard-room, coffee-room, dining-

room, drawing-room, &c., and also may have a certain number of bed-rooms. Besides being convenient for social intercourse, members may obtain their meals in them, served in the best style and at moderate cost. New members are admitted by ballot, and pay a certain entrance fee as well as an annual subscription. The English clubs have been imitated in different countries in Europe, but not with great success. In France, where they were introduced at an early period, they soon became associations purely political in their nature, and had no uniform and regular form, as they were only tolerated during revolutionary epochs. The Club des Jacobins, the Club des Feuillants, the Club des Cordeliers, and the Club de Montrouge, were the most famous clubs of the time of the first French revolution. After the revolutions of 1848 hosts of clubs started into existence in France, Germany, and Italy; but the institution has always failed to take a deep hold on European continental society.

**Clubbing**, a diseased condition of plants of the cabbage family produced by the larvæ of insects, consisting in the lower part of the stem becoming swollen and misshapen. Plants on ground exhausted by over-cultivation suffer chiefly.

**Club-foot** (Lat., *Talipes*), a congenital distortion of the foot. There are several varieties. Sometimes the foot is twisted inwards (*T. varus*); sometimes the heel is raised and the toes only touch the ground (*T. equinus*); sometimes the foot is twisted outwards (*T. valgus*); or it rests only on the heel (*T. calcaneus*). In most cases the deformity is curable by modern surgery.

**Club-hauling**, a method of tacking a ship in dangerous situations by letting go the lee-anchor as soon as the wind is out of the sails, her head being thus brought to the wind, and then cutting the cable and trimming the sails as soon as she pays off.

**Club-moss**, the common name of the plants of the order Lycopodiaceæ, or more particularly of the genus *Lycopodium*. See *Lycopods*.

**Clue**, of a square sail, is the lower corner; and hence *clue-lines* and *clue-garnets*, tackles to truss the clues up to the yard.

**Clunes**, an important mining town in the Australian colony of Victoria, 120 miles north-west of Melbourne. Pop. 4717.

**Cluniacs**. See next article.

**Cluny** (klù-nē), a town of Eastern France, dep. Saône-et-Loire, 11 miles N.W. Macon,

pop. 4007. Here was a Benedictine abbey, founded in 910, at one time the most celebrated in France, having 2000 monastic communities directly under its sway in France, Italy, Spain, England, &c., the inmates of which formed the congregation of Cluniac monks. Most of it was destroyed in 1789, and the present town is to some extent built of its debris and occupies its site.

**Clupe'idæ**, the herring family, the typical genus being *Clupĕa*, the herring, a family of fishes which includes the herring, sprat, white-bait, pilchard, &c.

**Clusiaceæ**. See *Guttiferæ*.

**Clustered column**, in arch., a pier which appears to consist of several columns or shafts clustered together; they are sometimes attached to each other throughout their whole height, and sometimes only at the capital and base.

**Clu'tha**, the largest river in New Zealand, in the southern part of the South Island. It receives the waters of Lakes Hawea, Wanaka, and Wakatipu, and flows in a S.E. direction, having a length of 150 miles. It is called also Molyneux.

**Clyde** (klid), a river of Scotland, which has its sources amid the hills that separate Lanarkshire from the counties of Peebles and Dumfries, passes by Lanark, Hamilton, Glasgow, Renfrew, Dumbarton, Greenock, &c., and forms finally an extensive estuary or firth before it enters the Irish Sea, at the southern extremity of the island of Bute. From its source to Glasgow, where navigation begins, its length is 70 or 80 miles. Its principal tributaries are the Douglas Water, the Mouse, the Nethan, the Avon, the Calder, the North Calder, the Kelvin, the White and Black Cart, and the Leven. Near Lanark it has three celebrated falls — the uppermost, Bonniton Linn, about 30 feet high; the next, Cora Linn, where the water takes three distinct leaps, each about as high; and the lowest, Stonebyres, also three distinct falls, altogether about 80 feet. The Clyde, by artificial deepening, has been made navigable for large vessels up to Glasgow, and is the most valuable river in Scotland for commerce. See *Glasgow*.

**Clyde, LORD**, Sir Colin Campbell, was born in Glasgow, in 1792, where his father, John M'Liver, a native of Mull, worked as a cabinet-maker. His mother's maiden name was Campbell, and she was the daughter of a small proprietor in Islay. By the assistance of his mother's relations he

was educated at the High School of Glasgow, and afterwards at the Military Academy, Gosport. In 1808 he received an ensign's commission in the 9th Regiment of Foot, having previously changed his name to Campbell, at the suggestion of his maternal



Lord Clyde.

uncle, an officer in the army. He served in Spain under Sir John Moore and Wellington, being engaged in the battles of Barossa and Vittoria, and having displayed distinguished gallantry at the siege of San Sebastian, where, as well as at the Bidassoa, he was severely wounded. In 1819–25 he was in the West Indies. In 1835 he attained the rank of lieutenant-colonel. In 1842 he was in China in command of the 98th Regiment, and on the termination of the Chinese war took active service in India, where he acquired such reputation in the second Sikh war as to receive the thanks of parliament and the title of K.C.B. In 1854 he became major-general, with the command of the Highland Brigade in the Crinæan war. His services at the battles of Alma and Balaclava, and during the war generally, were conspicuous, so that on the outbreak of the Indian mutiny he was appointed to the chief command there. Landing at Calcutta on 29th August, 1857, he relieved Havelock and Outram at Lucknow, and crushed the rebellion entirely before the end of the year. For his services here Sir Colin received the thanks of both Houses of Parliament, was created a peer with the title of Baron Clyde, and had an income of £2000 a year allotted him. In 1862 he was made field-marshal. He died August 14,

1863, and was buried in Westminster Abbey.

**Clys'ter**, an injection or enema, a medicated substance introduced into the lower bowel, usually for the purpose of expelling its contents, but sometimes also for the purpose of being retained, as when opium is thus administered in cases of diarrhœa.

**Clytemnes'tra**, in Greek mythology, daughter of King Tyndareus and Leda, and half-sister of Helen. During the absence of Agamemnon in the war against Troy she bestowed her favours on Ægisthus, and, in connection with him, murdered Agamemnon on his return from Troy, and, together with her paramour, governed Mycenæ for seven years. Her son Orestes killed them both. See *Agamemnon* and *Orestes*.

**Cni'dus**, or **GNIDUS**, an ancient Greek town in Caria, a province of Asia Minor, a great seat of the worship of Aphroditê (Venus), who had three temples here, in one of which was a famous statue of the goddess by Praxiteles.

**Coach**, a general name for all covered carriages drawn by horses and intended for the rapid conveyance of passengers. The earliest carriages appear to have been all open, if we may judge from the figures of Assyrian and Babylonian chariots found on the monuments discovered amidst the ruins of Nineveh and Babylon. At Rome both covered and uncovered carriages were in use. After the fall of the Roman Empire they went out of use again, and during the feudal ages the custom was to ride on horseback, the use of carriages being considered effeminate. They do not appear to have become common till the 15th century, and even then were regarded exclusively as vehicles for women and invalids. Later on they became, especially in Germany, part of the appendages of royalty. They seem to have been introduced into England about the middle of the 16th century, but were for long confined to the aristocracy and the wealthy classes. Hackney-coaches were first used in London in 1625. They were then only twenty in number, and were kept at the hotels, where they had to be applied for when wanted. In 1634 coaches waiting to be hired at a particular stand were introduced, and had increased to 200 in 1652, to 800 in 1710, and to 1000 in 1771. Stage-coaches were introduced into England about the same time as hackney-coaches. The first stage-coach in London appears to have



run early in the 17th century, and before the end of the century they were started on three of the principal roads in England. Their speed was at first very moderate, about 3 or 4 miles an hour. They could only run in the summer, and even then their progress was often greatly hindered by floods and by the wretched state of the roads generally. In 1700 it took a week to travel from York to London; in 1754 a body of Manchester merchants started a conveyance, the Flying Coach, of an improved kind, which did the journey to London in the unusually short period of four days and a half, and thirty years later a Mr. Palmer of Bath, after a considerable amount of opposition, succeeded in inducing the government to put in practice certain suggestions which he made, by which he showed that great saving both of time and money in the conveyance of passengers and letters would be effected. The result was the establishment of the system of mail-coaches, which continued to be the means of travelling in England until their place was taken by the railways. The first mail-coach started between London and Bristol on the 8th of August, 1784.

The manufacture of elegant carriages is a proof of much wealth and mechanical skill in a place, many different workmen being employed in their construction, and both the materials and the workmanship requiring to be of the best. British-built carriages, especially those made in London, hold the first place for a combination of strength and elegance. The principal modern varieties of the coach are the following: the Barouche, Landau, Brougham, Coupé, Buggy, Brits' a, Berlin, Brake, &c., which see under their different heads.

**Coach-dog**, a short-haired dog of moderate size, and rather handsome shape, white with numerous black spots, kept as an attendant upon carriages, and of no use otherwise. Called also Dalmatian dog.

**Coadju'tor**, a Latin term, nearly synonymous in its original meaning with *assistant*. The term is especially applied to an assistant bishop appointed to act for and succeed one who is too old or infirm for duty.

**Coagula'tion**, the changing of a fluid into a more or less solid substance, or the separation of a substance from a solution, through the substance becoming more or less solid. Thus albumen of egg can be dissolved in cold water, but if the solution be warmed, the albumen undergoes a change, separates out in white flocky masses, and cannot

again be redissolved in the water. Coagulation is well exemplified by the 'curdling' of milk and 'clotting' of blood.

**Coahuila** (kō-â-wē'lâ), a state of Mexico, on the frontier of the United States, rich in woods and pastures, and having several silver-mines; area, 50,890 square miles; pop. 130,026.

**Coaita**, *Atles paniscus*, one of the largest of the S. American monkeys, belonging to those known as spider monkeys, black in colour, and very docile in captivity.

**Coal**, a solid, opaque, inflammable substance, mainly consisting of carbon, found in the earth, largely employed as fuel, and formed from vast masses of vegetable matter deposited through the luxuriant growth of plants in former epochs of the earth's history. In the varieties of coal in common use the combined effects of pressure, heat, and chemical action upon the substance have left few traces of its vegetable origin; but in the sandstones, clays, and shales accompanying the coal, the plants to which it principally owes its origin are presented in a fossil state in great profusion, and frequently with their structure so distinctly retained, although replaced by mineral substances, as to enable the microscopist to determine their botanical affinities with existing species. The sigillaria and stigmaria, the lepidodendron, the calamite, and tree-ferns are amongst the commoner forms of vegetable life in the rocks of the coal formation. Trees of considerable magnitude have also been brought to light, having a recognizable relation to the modern araucaria. The animal remains found in the coal-measures indicate that some of the rocks have been deposited in fresh water, probably in lakes, whilst others are obviously of estuarine origin, or have been deposited at the mouths of rivers alternately occupied by fresh and salt-water. The great system of strata in which coal is chiefly found is known as the Carboniferous. There are many varieties of coal, varying considerably in their composition, as *anthracite*, nearly pure carbon, and burning with little flame, much used for furnaces and malt kilns; *bituminous* (popularly so called) or 'household coal;' and *cannel* or 'gas coal,' which burns readily like a candle, and is much used in gas-making. The terms semi-anthracitic, semi-bituminous, caking-coal, splint coal, &c., are also applied according to peculiarities. All varieties agree in containing from 60 to over 90 per cent of carbon, the other elements

being chiefly oxygen and hydrogen, and frequently a small portion of nitrogen. *Lignite* or *brown coal* may contain only 50 per cent. carbon. For manufacturing purposes coals are generally considered to consist of two parts, the volatile or bituminous portion, which yields the gas used for lighting, and the substance, comparatively fixed, usually known as *coke*, which is obtained by heating the coals in ovens or other close arrangements. About 160,000,000 tons of coal are annually mined in Britain, the value being over £40,000,000. Large quantities are exported. The British coal-fields, though comparatively extensive (covering about 9000 sq. miles), are far surpassed by those of several other countries, as the U. States and China, the former having coal-fields estimated to cover over 190,000 sq. miles; the latter over 200,000 sq. miles. Britain still mines the largest quantity, however, though being fast approached by the U. States. Other countries in which coal is worked are Belgium, France, Germany, Russia, India, N. S. Wales, and Canada. The total production of anthracite coal in Pennsylvania in 1892 was 46,850,450 tons of 2240 pounds, valued at the mines at \$82,412,000. In census year there were produced of bituminous coal 36,174,089 short tons, valued at \$27,953,215; amount of coke manufactured, 20,190,588 short tons. In Alabama the production of bituminous coal was 3,378,484 tons, valued at \$3,707,426. Maryland produced 2,939,715 short tons, valued at \$2,517,474 at the mines; West Virginia, 6,231,880 short tons, valued at \$5,086,584; Kentucky, 2,399,755 short tons, valued at \$2,374,339; Tennessee, 1,925,689 short tons, valued at \$2,338,309; Virginia, 865,786 short tons, valued at \$804,475; Georgia and North Carolina, 226,156 short tons, valued at \$339,382. The coal product west of the Mississippi river was: North and South Dakota, 28,907 short tons, valued at \$41,431; Kansas, 2,230,763 short tons, valued at \$3,294,754; Indian Territory, 752,832 short tons, valued at \$1,323,806; Iowa, 4,061,704 short tons, valued at \$2,507,453; Missouri, 2,567,823 short tons, valued at \$3,478,058; Arkansas, 279,584 short tons, valued at \$395,836; Texas, 128,216 short tons, valued at \$340,617; California, 121,820 short tons, valued at \$288,232; Washington, 993,724 short tons, valued at \$2,203,755. The chief applications of coal are as fuel for domestic purposes, for heat-

ing steam-boilers, for making gas, and in metallurgy. The production of the U. States in 1892 was 179,000,000 tons.

**Coal Brass**, the iron pyrites found in coal-measures, so named on account of its brassy appearance. Coal containing much pyrites is bad for iron smelting, and it is unpleasant for domestic use on account of the sulphurous acid which it gives off on burning. Coal brass is useful in the manufacture of copperas, and in alkali works.

**Coalbrookdale**, an English coal and iron producing district in Salop, along the bank of the Severn.

**Coal-cutting Machine**, any machine for cutting out coal in the pit, the chief objects they are intended to serve being the cheapening of the work, the saving of a large quantity of coal, which in the ordinary process of holing by hand-labour with the pick is broken up into slack and dust, and the removal of the danger attending upon the employment of hand-labour. The instruments of excavation in these machines are constructed on various principles, some having an action like that of an ordinary pick, others a horizontal cutting-tool. There are usually arrangements for regulating the depth and force, and to a certain extent the direction of the blow, and the precision obtained is fully equal to that of hand-labour.

**Coal-fish**, a species of the cod genus (*Gadus carbonarius*), named from the colour of its back. It grows to the length of 2½ feet, and is found in great numbers about the Orkneys and the northern parts of Britain. In Scotland it is generally known as the *Sethe* or *Seath*.

**Coal Gas**, the variety of carburetted hydrogen which produces common gaslight.

**Coaling-stations**, stations established by the British government at various important points throughout the empire, where the ships, both of the navy and the mercantile marine, may obtain supplies of coal. The utility of such stations, when properly fortified, as points of refuge, defence, and repair for British ships in the event of war can hardly be over-estimated. The more important of these stations are Aden, at Trincomalee (Ceylon), Singapore, Hong Kong, Sierra Leone, St. Helena, Mauritius, Jamaica, and Simon's Town (Cape Colony).

**Coalition**, a term used in diplomacy and politics to denote a union between different parties not of the same opinions, but who agree to act together for a particular object. Amongst states it is understood to mean

theoretically something less general in its ends, and less deeply founded than an *alliance*.

**Coal-measures**, the upper division of the carboniferous system, consisting of beds of sandstone, shale, &c., between which are coal-seams.

**Coal-plants**, such plants as have by their remains formed coal, chiefly allied to the ferns, lycopods, and horse-tails. See *Coal*.

**Coal-tar**, or GAS-TAR, a substance obtained in the distillation of coal for the manufacture of illuminating gas, a dark-coloured more or less viscid mass, consisting principally of oily hydrocarbons. It passes over with the gas into the condensers along with ammonia liquor, but being heavier than the latter, it is easily separated from it when the whole is allowed to stand. It was formerly of comparatively little use; but in recent years a great number of valuable products have been derived from it by distillation, such as ammonia, naphtha, creosote, carbolic acid, and benzene, while it is also the source of the whole series of aniline colours, and other dyes, of alizarine, salicylic acid, &c.

**Coamings**, raised frames rather higher than the deck, about the edges of the hatch-openings of a ship, to prevent the water on deck from running down.

**Coan'za**, a large river of Southern Africa, Lower Guinea, entering the Atlantic near 9° 10' s.

**Coasting-trade**, trade carried on by sea between the ports of the same country. This trade in the U. States, owing to the enormous coast-line, is far more extensive than in any other country, especially on Atlantic Ocean and G. of Mexico. It is closed to all save citizens and U.S. shipping.

**Coast Survey**, a scientific department of the government of the U. States, for the purpose of making geodetic and hydrographic surveys to determine the coast-line; of making charts of harbors and tide-waters, and of the bottom of the ocean along the coast; of indicating positions for the erection of light-houses; and the making of various meteorological and other observations. It extends its observations to all parts of the globe, as serviceable to navigation.

**Coast Mountains**, COAST RANGE, a range or series of ranges extending along the west of California at no great distance from the Pacific coast, and rising to the height of 8500 feet.

**Coatbridge**, a town in Scotland, Lanarkshire, 9½ miles east of Glasgow. The district abounds in coal and ironstone, and the place has rapidly grown from a trifling village to a thriving town, supported chiefly by the iron-works, engineering establishments, &c., in the neighbourhood. Pop. 17,500.

**Co'ati**, or COATI-MONDI, a name of S. American plantigrade carnivorous mammals, of the genus *Nasua*, belonging to the Ursidæ or bears, but recalling rather the raccoon or civets, and having a long proboscis or snout. They feed on worms, insects, and the smaller quadrupeds, but chiefly on eggs and young birds.

**Coat of Arms**. See *Arms* and *Heraldry*.

**Coat of Mail**, a piece of armour in the form of a shirt, consisting of a net-work of iron or steel rings, or of small laminæ or plates, usually of tempered iron, laid over each other like the scales of a fish, and fastened to a strong linen or leather jacket.

**Co'balt** (G. *kobalt*, *kobolt*, the same word as *kobold*, a goblin, the demon of the mines, so called by miners because cobalt was troublesome to miners, and at first its value was not known), a metal with the symbol Co, specific gravity 8.5, of a grayish-white colour, very brittle, of a fine close grain, compact, but easily reducible to powder. It crystallizes in parallel bundles of needles. It is never found in a pure state, but usually as an oxide, or combined with arsenic or its acid, with sulphur, iron, &c. Its ores are arranged under the following species, viz. *arsenical cobalt*, of a white colour, passing to steel gray; its texture is granular, and when heated it exhales the odour of garlic; *gray cobalt*, a compound of cobalt, arsenic, iron, and sulphur, of a white colour, with a tinge of red; its structure is foliated, and its crystals have a cube for their primitive form; *sulphide of cobalt*, compact and massive in its structure; *oxide of cobalt*, brown or brownish black, generally friable and earthy; *sulphate* and *arsenate of cobalt*, both of a red colour, the former soluble in water. The great use of cobalt is to give a permanent blue colour to glass and enamels upon metals, porcelain, and earthenwares.

**Cobalt-blue**, a compound of alumina and oxide of cobalt, forming a beautiful pigment often used in the arts.

**Cobalt-green**, a permanent green pigment prepared by precipitating a mixture of the sulphates of zinc and cobalt with carbonate

of sodium and igniting the precipitate after thorough washing.

**Coban'**, or **VERA PAZ**, a cathedral city, state of and 90 miles north-east of Guatimala. Pop. 12,000.

**Cob'bett**, **WILLIAM**, English writer and politician, was the son of a farmer and publican at Farnham in Surrey, and born there on 9th March, 1762. In 1783 he sought his way to London and obtained a situation as copying-clerk to an attorney, but after nine months he enlisted into the 54th Foot, and shortly after went with the regiment to Nova Scotia. His regular habits and attention to his duties soon brought him promotion, and he was sergeant-major when the regiment four years after returned to England (1791). During his service in the army, Cobbett had employed all his spare time in improving his education. He now obtained his discharge, married, and proceeded to America to commence as a political writer. Under the signature of 'Peter Porcupine,' he wrote papers and pamphlets of a strongly anti-republican tendency. In June, 1800, he sailed for England, and on his arrival started first the *Porcupine*, a daily paper, which had small success, then the *Weekly Political Register*, which soon acquired a great circulation. The *Register* had started as a Tory paper in support of Pitt, but gradually changed its politics till it became known as the most daring and uncompromising of the government's opponents. Three times heavily fined for libel, Cobbett continued his attacks on the government, in consequence of which he deemed it prudent to retreat to the United States (1817), transmitting his articles regularly, however, for the *Register*. In 1819 he returned to England, and made an unsuccessful attempt to get into parliament for Coventry. About the same period he commenced a series of papers entitled *Rural Rides*, afterwards reprinted, which contain charming pictures of English country scenery, and are among the best of his productions. In 1824-7 appeared his *History of the Reformation*, in which he vilifies Queen Elizabeth and the leading reformers. On the passing of the Reform Bill in 1832 he was returned as member for Oldham, but was indifferently successful in the House. He died 18th June, 1835. Cobbett is also the author of a *Parliamentary History of England from the Conquest to 1803*; *Advice to Young Men and Women*; *Village Sermons*, &c. He wrote in a pure and

vigorous English style, and his writings contain much useful information, and show a sound judgment wherever the matter did not go beyond his strong practical sense.

**Cob'den**, **RICHARD**, English politician, the 'apostle of free trade,' born in Sussex 3d June, 1804, died in London 2d April, 1865. After receiving a very meagre education he was taken as an apprentice into a ware-



Richard Cobden.

house in London belonging to his uncle, and in this situation he rapidly made up for the defects of his education by his own diligence. In 1830, being left by the failure of his uncle to his own resources, along with some relatives he started a cotton manufactory in Manchester, which in a few years was very successful. His first political writing was a pamphlet on England, Ireland, and America, which was followed by another on Russia. In both of these he gave clear utterance to the political views to which he continued through his life rigidly to adhere, advocating non-intervention in the disputes of other nations, and maintaining it to be the only proper object of the foreign policy of England to increase and strengthen her connections with foreign countries in the way of trade and peaceful intercourse. Having joined the Anti-Corn-Law League, formed in 1838, it was chiefly the extraordinary activity of Cobden, together with Bright and other zealous fellow-workers, which won victory for the movement. In 1841 Cobden entered parliament as member for Stockport, and after several years of unwearied efforts at last induced Sir Robert Peel, then prime minister, to bring in a bill for the repeal of the corn

laws, a measure which became law in 1846. Next year he was chosen member for the W. Riding of York, a constituency which he represented for ten years. His business, once highly prosperous, had suffered while he devoted himself to the agitation, and as a compensation for the loss he had thus sustained a national subscription was made, and a sum of about £70,000 presented to him. Cobden continued his labours as an advocate of parliamentary reform, economy, and retrenchment, and a policy of non-intervention, in all of which he found a firm and ready ally in Bright, both being strong opponents of the Crimean war. In 1859 he was chosen member for Rochdale, and was offered, for the second time, a place in the government, but again preferred to keep his independent position. He refused also a baronetcy and several other dignities. His last great work was the commercial treaty which he was the means of bringing about between Britain and France in 1860. During his later years he lived a good deal in retirement.

**Cobden Club**, an association formed about a year after the death of Mr. Cobden, mainly by the influence of Mr. Bright and Mr. T. B. Potter, for the purpose of encouraging the growth and diffusion of those economical and political principles with which Mr. Cobden's name is associated. The Cobden Club has distributed a vast number of books and pamphlets.

**Cobija** (kō-bē'há), or Puerto La Mar, a seaport formerly belonging to Bolivia, now in the territory of Antofagasta, Chili. Pop. about 4000.

**Coble**, or COBBLE, a low flat-floored boat with a square stern, used in salmon-fishery.

**Cob'lentz** (anciently *Confluentes*, from its situation at the confluence of the Rhine and Moselle), a fortified town of Germany, capital of Rhenish Prussia, finely situated on the left bank of the Rhine in the angle between it and the Moselle, and connected by a pontoon-bridge over the Rhine with the fortress of Ehrenbreitstein, this, along with its other fortifications, rendering it one of the strongest places in Germany, and capable of accommodating 100,000 men. The new part of the town is well built with broad streets and fine squares. The palace of the Elector of Treves is now a Prussian royal residence. Its industries embrace cigars, machinery, champagne-wines, pianos, and it has an important trade in Rhine and Moselle wines. Pop. 31,669.

**Cob-nut**, a large variety of the hazel-nut.

**Cobourg**, a port of Canada, prov. Ontario, on Lake Ontario, 69 m. E. by N. of Toronto. It is well built, has sundry manufactures, a good harbour, and an increasing trade. Pop. 4957.

**Cobra de Capello** (that is, 'snake of the hood'), the Portuguese name of the hooded or spectacled snake *Naja tripudians*, which is found in Southern Asia, a closely allied species (*Naja haje*), also called cobra, or asp, being found in Egypt. It is called spectacled snake from a singular marking on the back of the neck, while its other name is given from the remarkable manner in which it spreads out the skin on the sides of the neck and head when disturbed or irritated, raising the anterior part of its body so as to appear to stand erect, and expanding its hood. So exceedingly poisonous is its bite, that in numerous instances death has followed within a few minutes, and under ordinary circumstances a few hours is the longest term where prompt measures have not been taken. But indeed recovery rarely takes place, though injection of potash into the veins is said to be a remedy. In India thousands of natives lose their lives yearly through cobra bites. Its food consists of small reptiles, birds, frogs, fishes (being an excellent swimmer), &c. Its great enemy is the ichneumon. It is one of the snakes that the snake-charmers perform tricks with.

**Co'burg**, a town, Germany, capital of the duchy of Saxe-Coburg-Gotha, finely situated on the left bank of the Itz, 106 miles E. by N. Frankfort-on-the-Main. The principal buildings are the palace of the Duke of Saxe-Coburg-Gotha, and on an eminence overhanging the town the ancient castle of the dukes of Coburg, in which are still shown the rooms occupied by Luther during his concealment here, with his bedstead and pulpit. The Duke of Edinburgh has a residence here. Coburg has various manufactures, also extensive breweries. Pop. 16,210.

**Co'burg**, a thin fabric of worsted and cotton, or worsted and silk, twilled on one side, for ladies' dresses, intended as a substitute for merino.

**Coburg Peninsula**, a peninsula on the north coast of Australia in the Northern Territory of S. Australia.

**Cobweb**, the web or network spun by spiders to catch their prey.

**Coca**, *Erythroxylon Coca*, a South American plant, nat. order Erythroxyleæ. The leaf is a stimulating narcotic, and is chewed

by the inhabitants of countries on the Pacific side of South America, mixed with finely-powdered chalk. It has effects somewhat similar to those of opium. A small quantity of it enables a person to bear up against fatigue even when receiving less food than usual; and it prevents the difficulty of respiration experienced in climbing high mountains. Used in excess it brings on various disorders, and the desire for it increases so much with indulgence that a confirmed coca-chewer is said never to have been reclaimed. Coca-leaves depend for their influence on a crystallizable alkaloid called *cocaine* ( $C_{17}H_{19}NO_4$ ), which, besides having effects similar to the leaf, possesses valuable anæsthetic properties, and in recent times has been especially employed to prevent suffering in operations on the eye, having also similar effects when applied to the tongue, larynx, ear, &c.

**Cocaine** (kō'ka-in). See *Coca*.

**Cocceji** (kok-sā'yē), HEINRICH FREIHERR VON, a German jurist, born 1644 at Bremen, studied at Leyden in 1667, and in 1670 in England, at Oxford; was professor of law in various German and Dutch universities. His system of German public law (*Juris Publici Prudentia*) was almost a universal academical text-book. He died in 1719.

**Coccinella**, the lady-bird genus of insects. See *Lady-bird*.

**Coccolite**. See *Augite*.

**Cocco Root**, the name for the corms of several plants of the genus *Colocasia* (order Araceæ), used as food in tropical America.

**Coccus'teus**, a genus of fossil fishes of the Old Red Sandstone, having small berry-like tubercles studding the plates of their cranial buckler and body. It differs from *Cephalaspis* in having its back and belly both covered with a cuirass.

**Cocculus**, a genus of East Indian menispermaceous plants, consisting of climbers with heart-shaped leaves and small flowers. The species are generally powerful bitter febrifuges. The fruit of the *Cocculus Indicus* forms a considerable article of commerce, and is sometimes added to malt liquors to give bitterness.

**Coccus**, a genus of insects of the order Hemiptera, family Coccidæ, or scale-insects. The males are elongated in their form, have large wings, and are destitute of any obvious means of suction; the females, on the contrary, are of a rounded or oval form, about an eighth of an inch in length, have no wings, but possess a beak or sucker, by which they

suck up the juices of the plants on which they live. At a certain period of their life the females attach themselves to the plant or tree which they inhabit, and remain thereon immovable during the rest of their existence. In this situation they are impregnated by the male; after which their body increases considerably, in many species losing its original form and assuming that of a gall, and, after depositing the eggs, drying up and forming a habitation for the young. Some of these insects are troublesome in gardens, plantations, and hot-houses, while others are of great value. For example, kermes, cochineal, lac-lake, lac-dye, and gum-lac are either the perfect insects dried, or the secretions which they form. Kermes consist of the dried females of *Coccus ilicis*, found in great abundance upon a species of oak (*Quercus coccifera*), a native of the Mediterranean basin, and gathered before the eggs are hatched. It was known as a dye-stuff in the earliest times, but has partly fallen into disuse since the introduction of cochineal. Cochineal consists of the bodies of the females of the *Coccus cacti*, a native of Mexico, which feeds on various species of cactus, particularly on one called *nopal* (*Opuntia cochinillifera*). See *Cochineal*, *Lac*, and *China Wax*.

**Coccyx** (kok'siks), in anatomy, an assemblage of small bones attached to the lower extremity of the backbone. It is the homologue in man of the tail in animals.

**Cochabamba** (koch-), a town in the interior of Bolivia, capital of the province of Cochabamba, situated in a fertile valley 8435 feet above the level of the sea, with a good trade and considerable manufactures. Pop. 15,000.—The province has an area of 26,810 sq. miles; pop. 352,392.

**Cochin**, a seaport, Hindustan, Malabar district, Madras Presidency, on a small island; a picturesque place with many quaint old Dutch buildings. Its harbour, although sometimes inaccessible during the s.w. monsoon, is the best on this coast. Its trade, however, has for some years been declining. Cochin was one of the first places in India visited by Europeans. In 1502 Vasco da Gama established a factory, and soon after Albuquerque built a fort; he also died here in 1524. In 1663 the Dutch took the place, in 1795 the British. Pop. 15,698. See also next article.

**Cochin**, a small native state of India, on the s.w. or Malabar coast, connected with the Presidency of Madras, intersected by

numerous rapid streams descending from the Western Ghauts, and having several shallow lakes or backwaters along the coast. Chief products: timber, rice. The rajah has to pay £20,000 annually to the Indian government. Area, 1361 sq. miles; pop. (1891), 722,906, of whom 136,361 were Christians, partly belonging to the Jacobite and Nestorian churches established here in early times. The capital is Ernakolam. Formerly Cochin was the capital, a town on the Travancore estuary, within half a mile of the British town of Cochin (which see). Pop. 13,775.

**Cochin-China**, a country forming part of the peninsula of South-eastern Asia, and generally regarded as comprising the whole of Anam (which see) and Lower or French Cochin-China. The latter belonged to Anam till, in 1863, a portion of it was finally ceded to France after a war occasioned by the persecution of French missionaries; another portion being declared French territory in 1867. The territory thus acquired covers 23,082 sq. miles, and in 1891 had a pop. of 2,034,453. It is now organized in departments, prefectures, sub-prefectures, and cantons. The northern and eastern parts are hilly, but the rest of the territory consists almost entirely of well-watered low alluvial land. In the low and wet grounds much rice is grown. In the more elevated districts are grown tobacco, sugar-cane, maize, indigo, and betel. Among the other products are tea, gums, cocoa-nut oil, silk, spices. The climate is hot and unsuited for Europeans. Industrial arts are as yet limited among the natives. But they excel in the use of wood, of which their temples, pagodas, and tombs are built, being ornamented with elaborate carving. They live in villages adjacent to the rivers, which form almost the only means of communication. The only roads at present existing are those connecting Saïgon, the capital, with the principal towns; a railway of 42 miles connects Saïgon and Mytho. The principal export is rice, mainly to China; cotton and silk are also exported. The export and import trade is mostly carried on by British vessels, while the local trade is chiefly in the hands of the Chinese. The French number only several hundreds. The majority of the inhabitants are Anamese. In their monosyllabic language, their religious tendencies towards Buddhism or the system of Confucius, and in their social customs they much resemble the Chinese.—**UPPER COCHIN-CHINA** is the name some-

times given to the narrow strip of land on the east coast of Anam between the mountains and the sea extending from Tonquin on the north to Champa on the south, or from about 18° to 11° N. See *Anam*.

**Cochin-China**, a term applied to a variety of the domestic fowl, imported from Cochin-China. It is a large ungainly bird, valuable chiefly owing to its fecundity, eggs being laid even during the winter.

**Cochineal** (koch'in-ēl), a dye-stuff consisting of the dried bodies of the females of a species of insect, the *Coccus Cacti* (see *Coccus*), a native of the warmer parts of America, particularly Mexico, and found living on a species of cactus called the cochineal-fig. The insects are brushed softly off, and killed by being placed in ovens or dried in the sun, having then the appearance of small berries or seeds. A pound of cochineal contains about 70,000 of them. The finest cochineal is prepared in Mexico, where it was first discovered, and Guatemala; but Peru, Brazil, Algiers, the East and West Indies, and the Canary Islands have also entered into this industry with more or less success. Cochineal produces crimson and scarlet colours, and is used in making carmine and lake.

**Cochineal-fig**, a name given to *Opuntia cochinillifera* and two other species of cacti, natives of Mexico and the West Indies, the plants on which the cochineal insect lives. See *Cochineal*.

**Cochlea** (kok'lē-a), an important part of the internal ear, so called from its shape, which resembles that of a snail-shell.

**Cochlearia** (kok-lē-ā'ri-a), a genus of cruciferous plants, including the horseradish and common scurvy-grass.

**Cock**. See *Fowl*.

**Cockade'**, a plume of cock's feathers, with which the Croats in the service of the French in the 17th century adorned their caps. A bow of coloured ribbons was adopted for the cockade in France, and during the French revolution the tricoloured cockade—red, white, and blue—became the national distinction. National cockades are now to be found over all Europe.

**Cockatoo'**, the name of a number of climbing birds belonging to the family of the parrots, or Psittacidæ, or regarded as forming a distinct family Plectolophidæ or Cacatuidæ. They have a large, hard bill; a crest, capable of being raised and lowered at the will of the bird, commonly white, but sometimes yellow, red, or blue; a tail somewhat longer than that

of the parrot, and square or rounded; long wings; and, for the most part, a white plumage, though in some genera the plumage is dark. They are found especially in the Eastern Archipelago and Australia. They live on roots, fruits, grain, insects, &c., and



Leadbeater's Cockatoo (*Ptilinopus leadbeateri*).

usually congregate in flocks. These birds are easily tamed, and when domesticated become very familiar. The sulphur-crested cockatoo (*Ptilinopus galerita*) of Australia and Tasmania is a favourite cage-bird. So are the white-crested cockatoo (*P. albus*) and Leadbeater's cockatoo (*P. leadbeateri*), the pink cockatoo, whose crest is barred with crimson, yellow, and white. The Kaka of New Zealand (*Nestor meridionalis*) belongs to this family.

**Cock'atrice**, a fabulous monster anciently believed to be hatched from a cock's egg. It is often simply another name for the basilisk. See *Basilisk*.

**Cockburn** (ko'burn), HENRY DUNDAS, LORD, a distinguished Scottish judge, was the son of Archibald Cockburn, one of the barons of the Court of Exchequer, and born in 1779. He studied for the Scottish bar, and was admitted a member of the Faculty of Advocates in 1800. He attached himself to the Liberal party, rose to eminence in his profession, and became, under Earl Grey, solicitor-general for Scotland. He was a good example of the blending of wit, law, and learning common enough at the old Scots bar. He died in 1854. His *Memorials of His Time* (published in 1856) is an invaluable record of the social history of Scotland. Not less interesting is his life of his friend Lord Jeffrey, published in 1854.

**Cock'chafer**, a species of lamellicorn

beetle, genus *Melolontha*, remarkable for the length of its life in the worm or larva state, as well as for the injury it does to vegetation after it has attained its perfect condition. The common cockchafer (*Melolontha vulgāris*) is hatched from an egg which the parent deposits in a hole about 6 inches deep, which she digs for the purpose. At the end of about three months the insect emerges as a small grub or maggot, and feeds on the roots of vegetables in the vicinity with great voracity. When full grown it is over an inch in length; it makes its way underground with ease, and commits great devastation on grass and corn crops. In the fourth year the insect appears as a perfect coleopterous insect—a beetle over an inch long, of a black colour, with a whitish down. It usually emerges from the ground about the beginning of May, from which circumstance the English name *may bug* or *beetle* has been given it. In its perfect state it is very destructive to the leaves of various trees.

**Cocker**, a dog of the spaniel kind, allied to the Blenheim dog, used for raising woodcocks and snipes from their haunts in woods and marshes.

**Cocker**, EDWARD, an English engraver and teacher of writing and arithmetic in the 17th century, born about 1631. His work, *Cocker's Arithmetic*, upon which many succeeding treatises were framed, was published in 1677.

**Cock'ermouth**, a town, till 1885 a parliamentary borough, in Cumberland, England, at the mouth of the Cocker, 24 miles s.w. of Carlisle, now giving name to a parl. div. of the county. It has an old ruined castle, supposed to have been built soon after the Conquest. Thread and tweeds are manufactured; and there are coal-mines in the neighbourhood. Cocker-mouth is the birthplace of the poet Wordsworth. Pop. 1891, 5464.

**Cock-fighting**, an amusement practised in various countries, first perhaps among the Greeks and Romans. At Athens there were annual cock-fights, and amongst the Romans quails and partridges were also used for this purpose. It was long a favourite sport with the British, and the training, dieting, and breeding of cocks for fighting was the subject of many treatises. It is a favourite sport in the island of Cuba and in some of the United States.

**Cock-Lane Ghost**, an impudent hoax by which many Londoners were deceived in



1762, consisting in certain knockings heard in the house of a Mr. Parsons, in Cock-Lane, Stockwell. Dr. Johnson was among those who believed in the supernatural character of the manifestations; but it was found out that the knockings were produced by a girl employed by Parsons.

**Cockle**, a name for the bivalve molluscs of the genus *Cardium*, especially *Cardium edule*, common on the sandy shores of the ocean, much used as food. The general characteristics are: shells nearly equilateral and equivalvular; hinge with two small teeth, one on each side near the beak, and two larger remote lateral teeth, one on each side; prominent ribs running from the hinge to the edge of the valve.

**Cockle.** See *Corn-cockle*.

**Cockle-stove**, a stove in which the fire-chamber is surrounded by air-currents, which, after being heated sufficiently, are admitted into the apartments to be warmed.

**Cock'ney**, a nickname for a London citizen, as to the origin of which there has been much dispute. The word is often, but not always, employed slightingly as implying a peculiar limitation of taste or judgment. The epithet is as old at least as the time of Henry II.

**Cock of the Plains** (*Centrocercus urophasianus*), a large North American species of grouse, inhabiting desolate plains in the western states.

**Cock of the Rock** (*Rupicola aurantia*), a South American bird of a rich orange colour with a beautiful crest, belonging to the manakin family.

**Cock of the Woods.** See *Capercailzie*.

**Cockpit**, in a man-of-war, the place where the wounded are dressed in battle or at other times, and where medicines are kept.

**Cock'roach** (*Blatta*), a genus of insects belonging to the Orthopterous or straight-winged order, characterized by an oval, elongated, depressed body, which is smooth on its superior surface. They have parchment-like elytra, and in the female the wings are imperfectly developed. They are nocturnal in their habits, exceedingly agile, and devour provisions of all kinds. Cockroaches, like other orthopterous insects, do not undergo a complete metamorphosis: the larvæ and nymphs resemble the perfect insect, except that they have merely rudiments of wings. The eggs are carried below the abdomen of the female for seven or eight days till she finally attaches them to some solid body by means of a gummy fluid. The species are numerous. The *Blatta orientalis*, or common

kitchen cockroach (in England commonly called *black beetle*), was originally brought from Asia to Europe, and thence to America, where it is now common. The *Blatta americana*, or American cockroach, grows to be 2 or 3 inches long, including the antennæ. Throughout the southern portion of N. America and in the West India Islands this species is very troublesome.

**Cocks'comb**, a name given to flowering plants of various genera. By gardeners it is properly confined to *Celosia cristata*; but it is popularly applied to *Pedicularis* or lousewort, *Rhinanthus crista-galli* or yellow-rattle, as also to *Erythrina crista-galli*.

**Cock's-foot**, COCK'S-FOOT GRASS, a perennial pasture-grass (*Dactylis glomerata*) of a coarse, harsh, wiry texture, but capable of growing on barren, sandy places, and yielding a valuable food for sheep very early in the spring. It is a native of Britain and Europe generally, also of Asia and America. The name has been given to it because of the resemblance of its three-branched panicle to the foot of a fowl.

**Cockspur-thorn**, the *Cratægus crus-galli*, a North American shrub which has long been cultivated in Britain as a shrubby ornament. There are several varieties, which are admired for their snowy blossoms in May.

**Cockswain** (colloquially *cok'sn*), the officer who manages and steers a boat and has the command of the boat's crew.

**Cocles.** See *Horatius*.

**Co'coa**, a name given to the ground kernels of the cacao or chocolate tree prepared to be made into a beverage. See *Cacao*.

**Co'coa-nut**, or COCO-NUT, a woody fruit of an oval shape, from 3 or 4 to 6 or 8 inches in length, covered with a fibrous husk, and lined internally with a white, firm, and fleshy kernel. The tree (*Cocos nucifera*) which produces the cocoa-nut is a palm, from 40 to 60 feet high. The trunk is straight and naked, and surmounted by a crown of feather-like leaves. The nuts hang from the summit of the tree in clusters of a dozen or more together. The external rind of the nuts has a smooth surface. This incloses an extremely fibrous substance, of considerable thickness, which immediately surrounds the nut. The latter has a thick and hard shell, with three black scars at one end, through one of which the embryo of the future tree pushes its way. This scar may be pierced with a pin; the others are as hard as the rest of the shell. The kernel incloses a con-

siderable quantity of sweet and watery liquid, of a whitish colour, which has the name of *milk*. This palm is a native of Africa, the East and West Indies, and South America, and is now grown almost everywhere in tropical countries. Food, clothing, and the means of shelter and protection are all afforded by the cocoa-nut tree. The kernels are used as food in various modes of dressing, and yield on pressure an oil which is largely imported into various countries. (See *Cocoa-nut Oil*.) When dried before the oil is expressed they are known as *copra*. The fibrous coat of the nut is made into the well-known cocoa-nut matting; the coarse yarn obtained from it is called *coir*, which is also used for cordage. The hard shell of the nut is polished and made into a cup or other domestic utensil. The fronds are wrought into baskets, brooms, mats, sacks, and many other useful articles; the trunks are made into boats or furnish timber for the construction of houses. By boring the tree a white sweetish liquor called *toddy* exudes from the wound, and yields by distillation one of the varieties of the spirit called *arack*. A kind of sugar called *jaggery* is also obtained from the juice by inspissation.

**Cocoa-nut Beetle** (*Batocœra rubus*), a large beetle of the family Longicornes, the larvæ of which inhabit cocoa-nut trees and eat into the stems.

**Cocoa-nut Oil**, a solid vegetable fat, largely used in candle-making and in the manufacture of soaps and pomatum. This fat is got by pressure from the albumen of the cocoa-nut kernel, and is as white as lard, and somewhat firmer. Manilla and Ceylon send large quantities of the oil to Britain.

**Cocoa-plum**, the fruit of *Chrysobalanus Icaco*, family Rosaceæ, which is eaten in the West Indies. It is about the size of a plum, with a sweet and pleasant though somewhat austere pulp.

**Cocoon'**, the name given to the web or ball spun by caterpillars before passing into the chrysalis state. The valuable product thus obtained from the silkworm is well known.

**Cocos Islands**. See *Keeling Islands*.

**Cocum-butter**, COCUM-OIL, a pale, greenish-yellow solid oil got from the seeds of *Garcinia purpuræa*, a tree of the same genus with mangosteen, used in India to adulterate ghee or fluid butter. It is sometimes mixed with bear's-grease in pomatums.

**Cocy'tus** (from Greek *kōkuein*, to lament),

a river of ancient Epirus. Also, among the ancient Greeks, one of the rivers of the lower world.

**Cod** (*Gadus*), a genus of well-known soft-finned fishes, of the same family as the had-dock, whiting, ling, &c., distinguished by the following characters:—A smooth, oblong, or fusiform body, covered with small soft scales; ventrals attached beneath the throat; gills large, seven-rayed, and opening laterally; a small beard at the tip of the lower jaw; generally two or three dorsal fins, one or two anal, and one distinct caudal fin. The most interesting species is the *common* or *Bank cod* (*G. morrhua*). Though found plentifully on the coasts of other northern regions, as Britain, Scandinavia, and Iceland, a stretch of sea near the coast of Newfoundland is the favourite annual resort of countless multitudes of cod, which visit the *Grand Banks* to feed upon the crustaceous and molluscous animals abundant in such situations, and thus attract fleets of fishermen. Few members of the animal creation are more universally serviceable to man than the codfish. Both in its fresh state and when salted and dried it is a substantial and wholesome article of diet; the tongue is considered a delicacy, and the swimming-bladders or *sounds*, besides being highly nutritious, supply, if rightly prepared, an isinglass equal to the best Russian. The oil extracted by heat and pressure from the liver is of great medicinal value, and contributes considerably to the high economic value of the cod. The cod is enormously prolific, the ovaries of each female containing more than 9,000,000 of eggs; but the numbers are kept down by a host of enemies. The spawning season, on the banks of Newfoundland, begins about the month of March and terminates in June; but the regular period of fishing does not commence before April on account of the storms, ice, and fogs. The season lasts till the end of June, when the cod commence their migrations. The average length of the common cod is about 2½ or 3 feet, and the weight between 30 and 50 lbs., though sometimes cod are caught weighing three times this. The colour is a yellowish-gray on the back, spotted with yellowish and brown; the belly white or reddish, with golden spots in young individuals. It is caught by lines and hooks.

**Cod, CAPE**. See *Cape Cod*.

**Co'da**, in music, an adjunct to the close of a composition, for the purpose of enforcing the final character of the movement.

**Code**, in jurisprudence, is a name given to a systematic collection or digest of laws. The following are the chief codes which have affected the laws of Europe: The Theodosian Code (*Codex Theodosianus*), a compilation executed in 429 by a commission on behalf of Theodosius the Younger, and promulgated as law throughout the eastern and western empires. The Justinian Code (*Codex Justinianus*), a code compiled in 528, in the reign of the Emperor Justinian, incorporating all the codes, rescripts, edicts previously in use (see *Civil Laws*). The *Code Napoléon*, or *Code Civil*, undertaken under the consulship of Napoleon by the most eminent jurists of France, and published in 1804. The Code Napoléon (under which name other four codes of commercial law, criminal law, penal law, and law of procedure, drawn up at the same time, are often included) was a code in the strictest sense, that is, not merely a collection of laws, but a complete and exclusive statement of the law, virtually amounting to a recasting of the laws of the country. The influence, in law reform, of the New York State Codes of Civil and Criminal Procedure, has been marked. Their origination started the inauguration of a widespread reform in jurisprudence, extending to England, India, Australia, and most of the American States. The principal reforms were the abolition of the distinction between legal and equitable practice, and the simplification of procedure in general.

**Codeine** (kō-dē'in; Gr. *kōdeia*, a poppy-head), a crystallizable alkaloid obtained from opium, in which it exists to the amount of 6 or 8 oz. per 100 lbs. It is used to produce sleep and to soothe irritable coughs; and is the chief remedy in diabetes; dose  $\frac{1}{4}$  grain and upwards. It is a poison in excessive doses.

**Codet'ta**, in music, a short passage which connects one section with another.

**Co'dex**, an ancient written book; an important ancient MS., as one of the Scriptures or of some classical writer. A collection of laws was also called *codex*, as *Codex Theodosianus*, *Codex Justinianus* (see *Code*).—*Codex Alexandrinus*. See *Alexandrian Version*.—*Codex Sinaiticus*, a very ancient and valuable manuscript of the Greek Septuagint version of the Old Testament (including the Apocrypha), the whole of the New Testament, the Epistle of Barnabas, and a part of the Shepherd of Hermas, discovered in the monastery of St. Catherine,

on Mount Sinai, by Tischendorf, in 1859, and now at St. Petersburg. It is written on parchment in four columns, in early uncial characters, and bears every mark of being of great antiquity, perhaps even older than the Vatican MS. It is assigned by Tischendorf to the 4th century. The Old Testament is defective, but the New Testament is complete, not a word being wanting, which is the more remarkable inasmuch as it is the only manuscript of the New Testament which is complete, being from this and its early date of the highest value. It has been published in facsimile.—*Codex Vaticanus*, an ancient Greek MS. of the Old and New Testaments, so-called from being contained in the Vatican Library at Rome. It is written on thin vellum, in small uncial characters. The manuscript is assigned to the 4th century, and until the discovery of the Sinaitic was regarded as the best manuscript of the Old and New Testaments. The greater part of Genesis in the Old Testament, and the whole of the pastoral epistles and the Revelation in the New Testament are wanting. A facsimile of it was published in 1868.

**Cod'icil**, in law, a supplement to a will, to be considered as a part of it, either for the purpose of explaining or altering, or of adding to or subtracting from the testator's former disposition. A codicil may not only be written on the same paper or affixed to or folded up with the will, but may be written on a different paper and deposited in a different place. In general the law relating to codicils is the same as that relating to wills, and the same proofs of genuineness must be furnished by signature, and attestation by witnesses. A man may make as many codicils as he pleases, and, if not contradictory, all are equally valid.

**Codil'la**, the coarsest part of hemp, which is sorted out by itself; also, the coarsest part of flax.

**Codlin**, CODLING, a name for several varieties of kitchen apple with large or medium-sized fruit.

**Codling-moth**, a small moth, the larva of which feeds on the codling apple.

**Cod-liver Oil**, an oil extracted from the livers of different kinds of cod—the *Gadus morrhua* (common cod) being specified in the pharmacopœia—and allied species. The finest and palest oil is got from fresh and carefully-cleaned liver, the oil being extracted either in the cold or by a gentle heat. The darker kinds are got at a higher tem-

perature, and often from the livers in a putrefying state. Only the pale oils are used in medicine; the dark oils are too rank and acrid, and they are only used in dressing leather. Cod liver oil is a somewhat complex substance, but the main ingredients appear to be olein and margarin. Acetic, butyric, and other acids are also present, and to these the oil may owe some of its odour. This oil is now a recognized agent in the treatment of rheumatism, gout, scrofula, and especially of consumption, being taken internally and containing a quantity of easily-assimilated nutritive matter.

**Codogno** (ko-dō'nyō), a town in North Italy, prov. Milan, in a fertile district between the Po and Adda, with a large trade in Parmesan cheese. Pop. 9632.

**Cod'rington**, SIR EDWARD, English admiral, born in Gloucestershire 1770. He entered the navy in 1783, obtained a gold medal for his services at the battle of Trafalgar, and was afterwards actively employed both in the Peninsular and second American wars. In 1827 he commanded the united squadron that overthrew the Turkish fleet in the battle of Navarino. From 1832 to 1837 he was member of parliament for Devonport. He died in London in 1851.

**Cod'rus**, according to Greek legend the last king of Athens. Having learned that the enemies of his country would be victorious, according to the declaration of an oracle, if they did not kill the Athenian king, he voluntarily entered their camp, provoked a quarrel, and was slain. The grateful Athenians abolished the royal dignity, substituting that of archon, esteeming no one worthy to be the successor of Codrus.

**Coeffic'ient**, in algebra, a multiplier of a quantity. Thus in the expression  $3ax$  we should understand as the coefficient of  $x$ ,  $3a$ , and as the coefficient of  $ax$ , 3.

**Coehorn** (kō'horn), MENNO, BARON VAN, a Dutch military engineer, born 1641, died 1704. Having entered the Dutch military service he distinguished himself by his invention of small mortars, called after him *coehorns*, but more by his eminence as a master of the art of fortification, whence he has been called the Dutch Vauban. He fortified almost all the strong places in Holland.

**Coel.** See *Aligarh*.

**Cœlentera'ta** (Gr. *koilos*, hollow, *enteron*, an intestine), a sub-kingdom of animals, including those whose alimentary canal communicates freely with the general cavity of

the body ('the somatic cavity'). The body is essentially composed of two layers or membranes, an outer layer or 'ectoderm' and an inner layer or 'endoderm.' No circulatory organs exist, and in most there are no traces of a nervous system. Peculiar stinging organs or 'thread-cells' are usually, if not always, present, and in most cases there is a radiate or starlike arrangement of the organs, which is especially perceptible in the tentacles, which are in most instances placed round the mouth. Distinct reproductive organs exist in all, but multiplication also takes place by fission and budding. The Cœlenterata are divided into two great sections, the Actinozoa and the Hydrozoa, and include the medusas, corals, sea-anemones, &c. They are nearly all marine animals.

**Cœ'lestin.** See *Celestine*.

**Cœle-Syria** (that is, 'Hollow-Syria'), the large valley lying between the Lebanon and Anti-Lebanon mountain ranges in Syria. Near its centre are the ruins of Baalbek.

**Cœnobite.** See *Anchorite*.

**Coethen**, or KÖTHEN (keu'ten), a town of Germany, formerly capital of the duchy of Anhalt-Coethen, now forming part of the duchy of Anhalt, 80 miles s.w. Berlin. The ducal castle is now occupied as a gymnasium and otherwise. Beet-root sugar is a staple article of manufacture and commerce. Pop. 17,473.

**Coffee** is the seed of an evergreen shrub which is cultivated in hot climates, and is a native of Abyssinia and of Arabia. This shrub (*Coffea arabica*) is from 15 to 20 feet in height, and belongs to the Rubiaceæ. The leaves are green, glossy on the upper surface, and the flowers are white and sweet-scented. The fruit is of an oval shape, about the size of a cherry, and of a dark-red colour when ripe. Each of these contains two cells, and each cell a single seed, which is the coffee as we see it before it undergoes the process of roasting. Great attention is paid to the culture of coffee in Arabia. The trees are raised from seed sown in nurseries and afterwards planted out in moist and shady situations, on sloping grounds or at the foot of mountains. Care is taken to conduct little rills of water to their roots, which at certain seasons require to be constantly surrounded with moisture. When the fruit has attained its maturity cloths are placed under the trees, and upon these the labourers shake it down. They afterwards spread the berries on mats, and ex-

pose them to the sun to dry. The husk is then broken off by large and heavy rollers of wood or iron. When the coffee has been thus cleared of its husk it is again dried in the sun, and, lastly, winnowed with a large fan, for the purpose of clearing it from the pieces of husks with which it is intermingled. A pound of coffee is generally more than the produce of one tree; but a tree in great vigour will produce 3 or 4 lbs. The best coffee is imported from Mocha, on the Red Sea. It is packed in large bales, each containing a number of smaller bales, and when good appears fresh and of a greenish-olive colour.

Coffee Plant (*Coffea arabica*).

Next in quality to the Mocha coffee may perhaps be ranked that of Southern India and that of Ceylon, which is strong and well flavoured, and is brought to Great Britain in large quantities. Java and Central America also produce large quantities of excellent coffee. Brazilian coffee, though produced more abundantly than any other, stands at the bottom of the list as regards quality. Liberian coffee may also be mentioned. Of the best Mocha coffee grown in the province of Yemen little or none is said to reach the Western markets. Arabia itself, Syria, and Egypt consume fully two-thirds, and the remainder is exclusively absorbed by Turkish or Armenian buyers. The only other coffee which holds a first rank in Eastern opinion is that of Abyssinia. Then comes the produce of India, which those accustomed to the Yemenite variety are said to consider hardly drinkable. American coffee holds in the judgment of all Orientals the very last rank. The Dutch were the first to extend the cultivation of coffee beyond the countries to which it is native. About 1690 some coffee seeds were brought to Java, where they were planted and produced fruit. By 1718 the Dutch planters of Surinam had entered on the cultivation of coffee with success, and ten years after it was introduced from that colony by the English into Jamaica, and by the French into Martinique. It was not till 1774 that the planters of

Brazil, now the greatest producers of coffee in the world, commenced its cultivation. Coffee as an article of diet is of but comparatively recent introduction. To the Greeks and Romans it was wholly unknown. From Arabia it passed to Egypt and Turkey, whence it was introduced into England by a Turkey merchant named Edwards in 1652, whose Greek servant, named Pasqua, first opened a coffee-house in London. In 1671 an Armenian named Pascal set up a coffee-house in Paris. In Great Britain much less is drunk than on the Continent of Europe or in the United States and Canada, tea being the British national beverage. The excellence of coffee depends in a great measure on the skill and attention exercised in roasting it. If it be too little roasted it is devoid of flavour, and if too much it becomes acrid, and has a disagreeable, burned taste. Coffee is used in the form either of an infusion or decoction, of which the former is decidedly preferable, both as regards flavour and strength. The fine aromatic oil which produces the flavour and strength of coffee is lost by boiling. The best mode is to pour boiling water through the coffee in a biggin or strainer, which is found to extract nearly all the strength; or to pour boiling water upon it and set it upon the fire, not to exceed ten minutes. Prepared in either way it is fine and strong. In the Asiatic mode of preparing coffee the beans are pounded, not ground; and though the Turks and Arabs boil the coffee, they boil each cup by itself and only for a moment, so that the effect is much the same as that of infusion. In Arabia some additional spicing, generally of saffron or some aromatic seeds, is considered indispensable; but neither Turks nor Arabians use sugar or cream with coffee. Since the middle of the eighteenth century both the culture and consumption of coffee have continually increased. The principal supply of the United States is derived from Brazil, which furnishes 75 per cent. of the whole import. It is known in commerce as "Rio." Coffee acts as a nervous stimulant, a property which it owes mainly to the alkaloid caffeine (which see). It thus promotes cheerfulness and removes languor, and also aids digestion; but in some constitutions it induces sleeplessness and nervous tremblings.

**Coffee-bug**, *Lecanium coffea*, an insect of the Coccus family, very destructive in coffee plantations.

**Coffer**, in architecture, a sunk panel or compartment in a ceiling of an ornamental character, and usually enriched with mouldings, and having a rose, pomegranate, &c., in the centre.

**Coffer-dam**, a temporary wooden inclosure formed in water in order to obtain a firm and dry foundation for bridges, piers, &c. It is usually formed of two or more rows of piles driven close together, with clay packed in between the rows.

**Coffin**, the chest or box in which a dead body is inclosed for burial. Coffins were used by the ancients mostly to receive the bodies of persons of distinction. Among the Romans it was latterly the almost universal custom to consume the bodies with fire, and deposit the ashes in urns. In Egypt coffins seem to have been used in ancient times universally. They were of stone, earthenware, glass, wood, &c. A sort of ancient coffin is known as a *sarcophagus*. Coffins among Christians were introduced with the custom of burying. (See *Burial*.) Modern coffins are usually made of wood, and are sometimes inclosed in a leaden case. It has been often proposed that they should be made with a hole opposite the place of the mouth of the body, so as to allow breathing in case of revival. Of course it would be necessary, at the same time, to let the coffin stand for some days in a convenient place, as is the custom in some parts of Germany. It has recently been proposed to employ coffins of wicker-work, while some strenuously advocate the burning of all dead bodies. See *Uremation*.

**Cognac** (kon-yák), a town in France, dep. Charente, and near the river Charente, 22 miles w. Angoulême, pleasantly situated on a hill, crowned by the remains of an old castle. It is famous for the brandy which bears its name, and which is exported to all parts of the world. Pop. 14,248.

**Cognates**, relations by the mother's side. See *Agnates*.

**Cog'nisance**, in heraldry, a crest, coat of arms, or similar badge of distinction appertaining to a person or family; in law, judicial or formal notice or acknowledgment of a fact.

**Cogno'men**, the hereditary family name (such as Cicero, Cato, &c.) among the ancient Romans. The other two names generally borne by every well-born Roman, viz. the *prænomen* and *nomen* (as in Marcus Tullius Cicero), served to denote the individual (Marcus), and the *gens* (Tullius) or clan to which his family belonged.

**Cogno'vit**, in law, is a written confession given by the defendant that the action of the plaintiff is just, or that he has no available defence.

**Cog-wheel**, a wheel with cogs or teeth.

**Coheir**, COHEIRESS, a joint heir or heiress, one who succeeds to an inheritance that is to be divided among two or more.

**Cohemoth**. See *Ecclesiastes*.

**Cohesion**, the force by which the various particles of the same material are kept in contact, forming one continuous mass. Its action is seen in a solid mass of matter, the parts of which cohere with a certain force which resists any mechanical action that would tend to separate them. In different bodies it is exerted with different degrees of strength, and it is measured by the force necessary to pull them asunder. Cohesion acts at insensible distances, or between particles in contact, and is thus distinguished from the attraction of gravitation. It unites particles into a single mass, and that without producing any change of properties, and is thus distinguished from *adhesion*, which takes place between different masses or substances; and from chemical attraction or affinity, which unites particles of a different kind together and produces a new substance. Hardness, softness, tenacity, elasticity, malleability, and ductility are to be considered as modifications of cohesion. The great antagonist of cohesion is heat.

**Cohesion Figures**, a class of figures produced by the attraction of liquids for other liquids or solids with which they are in contact, and divided into *surface*, *submersion*, *breath*, and *electric cohesion figures*. Thus a drop of an independent liquid, as oil or alcohol, will spread itself out on the surface of water always in a definite figure, but differing with each fluid dropped on the water. *Breath figures* are produced by putting a drop of the liquid to be examined on a slip of mica, and breathing on it, when each fluid takes a distinct characteristic shape. *Electric cohesion figures* are produced by electrifying drops of various liquids placed on a plate of glass.

**Cohoba'tion**, the repeated distillation of the same liquid from the same materials.

**Cohoes** (ko-hōz'), a city of Albany county, New York, U.S., on the west bank of the Hudson river, at the mouth of the Mohawk, with unlimited water-power derived from the Mohawk falls. There are large cotton and other mills. Pop. 1890, 22,509.

**Co'hort**. See *Legion*.

**Cohune Oil** (ko-hūn'), a product of the kernel of *Attalēa funifēra*, a palm-tree found in S. America. It resembles cocoa-nut oil, but is more oleaginous, burning, it is said, twice as long.

**Coif**, in England, the badge of serjeants-at-law, who are called serjeants of the coif, from the lawn coif or cap which they wore under their caps when created serjeants.

**Coimbatore** (ko-im-ba-tōr'), a town of Hindustan, Madras Presidency, capital of district to which it gives name, situated on the river Noyil, with wide streets, abundant water, and a healthy climate. Pop. 38,967. —The district has an area of 7842 square miles. It is fertile, producing sugar, cotton, rice, and tobacco; and well watered by several rivers. Pop. 1,657,690.

**Coimbra** (ko-im'brá), a city of Portugal, province of Beira, partly on a hill, partly on low ground, on the river Mondego, 115 miles N.N.E. Lisbon. It is a bishop's see, and contains an old and a new cathedral, a hospital, and a university, which is the only one in the kingdom (800–900 students). The city has also a college of arts. Manufactures: linen, pottery, articles of horn. The environs produce oil, wine, lemons, and oranges of excellent quality. Pop. 13,369.

**Coin** (ko in'), a town, Spain, Andalusia, province of, and 21 miles w. Malaga, on a gentle declivity facing the north. In the neighbourhood are quarries of marble. Pop. 10,065.

**Coinage, COINS.** See *Coining, Money, Numismatics, Currency.*

**Coining**, the art of converting pieces of metal into current coins for the purposes of commerce, usually performed in a government establishment called a *mint*. It is one of the prerogatives of the supreme power in all states, and counterfeiting or otherwise tampering with the coin is severely punished. In the United States the Bureau of the Mint was established as a division of the Treasury Department in 1873. It has charge of the coinage for the government and makes assays of precious metals for private owners. The rolling machines are four in number. The rollers are adjustable and the space between them is governed by the operator. About two hundred ingots are run through per hour on each pair of rollers. When the rolling is completed the strip is about six feet long. As it is impossible to roll perfectly true it is necessary to "draw" these strips, after being softened by annealing. The drawing

benches resemble long tables, with a bench on either side, at one end of which is an iron box secured to the table. In this are fastened two perpendicular steel cylinders. These are at the same distance apart that the thickness of the strip is required to be. It is drawn between the cylinders, which reduces the whole to an equal thickness. These strips are now taken to the cutting machines, each of which will cut 225 planchets per minute. The press now used consists of a vertical steel punch. From a strip worth \$1100 about \$800 of planchets will be cut. These are then removed to the adjusting room, where they are adjusted. After inspection they are weighed on very accurate scales. If a planchet is too heavy, but near the weight, it is filed off at the edges; if too heavy for filing, it is thrown aside with the light ones to be re-melted. The planchets, after being adjusted, are taken to the coining and milling rooms, and are passed through the milling machine. The planchets are fed to this machine through an upright tube, and as they descend are caught upon the edge of a revolving wheel and carried about a quarter of a revolution, during which the edge is compressed and forced up. By this apparatus 560 half-dimes can be milled in a minute; for large pieces the average is 120. The massive but delicate coining presses coin from 80 to 100 pieces a minute. These presses are attended by ladies and do their work in a perfect manner. After being stamped the coins are taken to the coiner's room. The light and heavy coins are kept separate in coining, and when delivered to the treasurer they are mixed in such proportions as to give him full weight in every delivery. By law, the deviation from the standard weight, in delivering to him, must not exceed three pennyweights in one thousand double eagles. The coinage for 1892 was—gold, \$35,506,988; silver, \$14,989,279; minor coins, \$1,296,710; total, \$51,792,977.

**Coir**, cocoa-nut fibre, fibre from the husk of the nut, from which are manufactured matting, bagging, ropes, and cables. Coir cordage, from lasting well in salt-water, as also from its lightness, strength, and elasticity, is preferable in many respects to ropes of hemp. Mats and matting are now largely made of coir, which is also used in coarse brushes, for stuffing purposes, &c.

**Coire** (kwär), or CHUR (*hör*), the capital of the Swiss canton of the Grisons, on the

rivers Plessur and Rhine. It is irregularly built, and possesses many houses in the ancient style of architecture. Not far from Coire the Rhine begins to be navigable for small vessels. Pop. 8889.

**Coix**, a genus of grasses. See *Job's Tears*.

**Coke**, the carbonaceous residue of coal which has been heated in an oven or retort, or in any way by which little air is admitted, until all volatile matter has been expelled. The simplest method of producing coke is based on the preparation of wood charcoal, the coal being arranged in heaps which are smothered with clay or coal-dust, and then set on fire, sufficient air being admitted to keep the mass at the proper temperature for decomposition without wasting the coke. After the volatile portions are got rid of, the heap is allowed to cool, or is extinguished with water, and the coke is then ready. Methods of heating the coal in close or open ovens until the gaseous and fluid products are driven off are also commonly used. Gas-coke is that which remains in the retorts after the gas has been given off. Good oven-coke has an iron-gray colour, sub-metallic lustre, is hard, and somewhat vesicular; but gas-coke has rather a slagged and cindery look, and is more porous. Coke contains about 90 per cent of carbon, and is used where a strong heat is wanted without smoke and flame, and it is accordingly largely consumed in drying malt and similar purposes. It used to be burned regularly in locomotive-engines, but raw coal is now commonly substituted. The largest quantities are consumed in smelting operations.

**Coke**, SIR EDWARD, an eminent English lawyer, was the son of a Norfolkshire gentleman and was born in 1551. After finishing his education at Cambridge he went to London, and entered the Inner Temple. His reputation and practice rapidly increased. He was chosen recorder of the cities of Norwich and of Coventry, knight of the shire for his county, and, in spite of the rivalry of Bacon, attorney-general. As such he conducted the prosecutions for the crown in all great state cases, notably those of Essex and Sir Walter Raleigh, which Coke conducted with great rancour and asperity. In 1613 he became Chief-justice of the Court of King's Bench; but his rough temper and staunch support of constitutional liberties brought him into disfavour with King James and his courtiers. In 1621 he was committed to the Tower, and soon after expelled from the privy-council. In 1628

he was chosen member for Buckinghamshire, and greatly distinguished himself by his vindication of the rights of the Commons, and by proposing and framing the famous Petition of Rights. This was the last of his public acts. On the dissolution of the



Sir Edward Coke.

parliament he retired to his seat in Buckinghamshire, where he died, September, 1634. His principal works are Reports, from 1600 to 1615; Institutes of the Laws of England, in four parts; the first of which contains the celebrated commentary on Littleton's Tenures ('Coke upon Littleton'); A Treatise of Bail and Mainprise, Complete Copyholder.

**Col** (French, *neck*), an elevated mountain pass between two higher summits. The name is used principally in those parts of the Alps where French is commonly spoken.

**Cola**. See *Kola*.

**Col'ander**, a vessel with a bottom perforated with little holes for straining liquors.

**Colberg**, or KOLBERG, a Prussian fortified seaport in Pomerania, on the river Persante, 1 mile from the sea, with a good shipping trade and well-frequented baths. Formerly a regular fortress, it has often been held against strong armies. Pop. 16,027.

**Colbert** (kol-bār), JEAN BAPTISTE, a celebrated French minister of finances, born at Rheims in 1619. After serving in various subordinate departments Colbert was made intendant, and at length comptroller-general of the finances. His task was a difficult one. He found disorder and corruption everywhere. The state was the prey of the farmers-general, and at the same time maintained only by their aid. The people were obliged to pay 90,000,000 livres



of taxes, of which the king received scarcely 35,000,000, the revenues were anticipated for two years, and the treasury empty. Colbert at once commenced a system of stringent reforms, abolishing useless offices, retracting burdensome privileges, diminishing salaries, and distributing and collecting the taxes by improved methods till he had reduced them almost to one-half. To his talents, activity, and enlarged views the development and rapid progress of industry and commerce in France were largely due. He constructed the Canal of Languedoc; declared Marseilles and Dunkirk free ports; granted premiums on goods exported and imported; regulated the tolls; established insurance offices; made uniform laws for the regulation of commerce, laboured to render the pursuit of it well esteemed, and invited the nobility to engage in it. The French colonies in Canada, Martinique, &c., showed new signs of life; new colonies were established in Cayenne and Madagascar, and to support these Colbert created a considerable naval force. Under the protection and in the house of the minister (1663) the Academy of Inscriptions was founded. Three years afterwards he founded the Academy of Sciences, and in 1671 the Academy of Architecture. He enlarged the Royal Library and the Garden of Plants, and built an observatory, in which he employed Huyghens and Cassini. He began the measurement of the meridian in France, and sent men of science to Cayenne. After having conferred the greatest benefits on his country he died in 1683, out of favour with the king and the people.

**Colburn**, ZERAH, 'the calculating boy,' born in Vermont, U.S., in 1804, died in 1840. Before his sixth year he began to manifest wonderful powers of arithmetical computation, and in public exhibitions astounded learned mathematicians by the rapidity and accuracy of his processes, but the faculty left him when he grew up. After acting as a teacher and itinerant preacher, he was latterly professor of languages at Norwich University, Vermont.

**Colchester**, a mun. and parl. borough and river-port, England, county Essex, 51 miles N.E. by E. London, mostly situate on the summit and sides of an eminence rising from the river Colne; well built and amply supplied with water. It has a good coasting trade and employs a great number of small craft in the oyster-fishery. It is a place of high antiquity, there being no place

in the kingdom where so great a quantity and variety of Roman remains have been found as here. It is supposed to be the *Camalodunum* of the Romans, and was called *Colne Cæster*, from its situation on the Colne, by the Anglo-Saxons. Has one member of parliament. Pop. 28,374.

**Colchester**, Chittenden co., Vt., 20 m. S. of St. Albans, has various manuf. Pop. 1890, 5143.

**Colchicin** (kol'chi-sin), an alkaloid obtained from colchicum, used for the alleviation or cure of gout and rheumatism. It acts as an emetic, diuretic, and cathartic, in large doses as a narcotico-acrid poison.

**Colchicum** (kol'chi-kum), a genus of plants, order Melanthaceæ, allied to the lilies. The *Colchicum autumnale*, or meadow saffron, is a bulbous rooted, stemless, perennial plant, which grows in various parts of Europe, and is common in pastures in parts of England. From a small corm or bulb buried about 6 inches deep, and covered with a brittle brown skin, there rises in the early autumn a tuft of flowers having much the appearance of crocuses, flesh-coloured, white, or even variegated. They soon wither, and the plant disappears till the succeeding spring, when some broad leaves are thrown up by each corm along with a triangular oblong seed-vessel. The plant is acrid and poisonous, and cattle are injured by eating it, but it yields a medicine valuable in gout and rheumatism. See *Colchicin*.

**Colchis** (kol'kis), the ancient name of a region at the eastern extremity of the Black Sea, resting on the Caucasus, famous in Greek mythology as the destination of the Argonauts, and the native country of Medea.

**Colcothar**, an impure brownish-red oxide of iron, which forms a durable colour, but is most used in polishing glass and metals.

**Cold**, the absence of sensible heat, especially such a want of heat as causes some discomfort or uneasiness. The temperature in which man and other animals live is generally below the natural heat of the body, but this is easily kept up in ordinary cases by means of the food taken in and digested. A high degree of cold, however, produces bodily depression, and is a frequent source of disease, or even of death. For the ailment called a *cold*, see *Catarrh*.

**Cold-blooded Animals**, a term applied to those animals, such as reptiles, the temperature of whose blood ranges from the freezing-point, or near it, to 90° Fahr., in accordance with that of the surrounding medium.

**Cold Cream**, a cooling ointment prepared in various ways. A good variety may be made by heating four parts of olive-oil with one of white wax. This ointment cools the skin, rendering it soft and pliable, and is successfully applied for the cure of chapped hands.

**Coldstream**, a village of Scotland in Berwickshire, on the Tweed. When General Monk quartered here in 1659-60 he raised an infantry regiment, which is called *the Coldstream Guards*.

**Coldwater**, a town in Branch Co., Mich. State school for orphans. Pop. 5247.

**Cold-water Cure.** See *Hydrophathy*.

**Cole, THOMAS**, a landscape-painter. He was born in England in 1801, but was taken quite young to America, where he died in 1848. Among his works are the *Voyage of Life*, *Course of Empire*, *Hunter's Return*, *Views in the White Mountains*, &c.

**Colebrooke, HENRY THOMAS**, Oriental scholar, born in London in 1765, died there 1837. He became professor of Sanskrit at Calcutta and director of the Bengal Asiatic Society. His translations from the Sanskrit and his essays on Hindu subjects are valuable contributions to Oriental scholarship.

**Colen'so, JOHN WILLIAM, D.D.**, Bishop of Natal, born in 1814; educated at Cambridge; assistant-master at Harrow till 1842; appointed in 1853 first bishop of Natal, South Africa. He published treatises on Algebra and Arithmetic which have been popular text-books in schools and colleges. His work on the Pentateuch and Book of Joshua, which called in question the historical accuracy of these books, involved the author in a conflict with his ecclesiastical superiors, and he was deposed by the Bishop of Cape Town.

But the decisions of the privy-council and Court of Chancery were in his favour, and he continued to officiate as bishop. He died in 1883.

**Coleoptera** (Greek *koleos*, a sheath, and

*pteron*, a wing), an order of insects, commonly known as *beetles*. They have four wings, of which the two superior (*elytra*) are not suited to flight, but form a covering and protection to the two inferior, and are

of a hard and horny or parchment-like nature. The inferior wings, when not in use, are folded transversely under the superior. The coleoptera undergo a perfect metamorphosis. The larva generally resembles a short thick worm with six legs and a scaly head and mouth.

**Coleraine** (kōl-rān'), a town, Ireland, county of Londonderry, on both sides of the river Bann, 47 miles n.w. of Belfast. Its trade, chiefly in linen, agricultural produce, and provisions, is considerable. Until 1885 it returned one member to the House of Commons. Pop. 6694.

**Coleridge** (kōl'rij), HARTLEY, eldest son of Samuel Coleridge, was born at Clevedon, near Bristol, on 19th September, 1796. In 1815 he went to Oxford, where, three years after, he took his degree with high honours. Unfortunately he had contracted a propensity for drinking, and was deprived, on account of his intemperate habits, of a fellowship he had obtained from Oriel College. He then left Oxford and took up his residence at London, but latterly he resided in the lake country where he occupied himself with literary composition. In verse, his sonnets, and in prose his biographies (*Worthies of Yorkshire and Lancashire* and *Life of Massinger*) are the most important of his works. He died 6th January, 1849. His life was written by his brother, DERWENT, born 1800, died 1883. In 1841-64 he was principal of St. Mark's College, Chelsea, in 1864-80 rector of Hanwell.

**Coleridge, HENRY NELSON**, was the son of Colonel Coleridge, a brother of the elder Coleridge, and born in 1800. A distinguished student at Cambridge, and a contributor along with Macaulay and Praed to *Knight's Quarterly Magazine*, he is best known as the editor of the *Literary Remains* and *Table Talk* of his uncle, Samuel Taylor Coleridge. He died 26th January, 1843. His wife, SARA COLERIDGE, a daughter of the great poet, aided her husband materially in his editorial work and continued it after his death. She died 3d May, 1852.

**Coleridge, SAMUEL TAYLOR**, a celebrated English poet and philosopher, was born on 21st October, 1772, at Ottery St. Mary, Devonshire, of which his father was vicar. Sent to school at Christ's Church Hospital, to which he had obtained a representation, young Coleridge took little interest in the ordinary sports of childhood, and was noted for a dreamy abstracted manner, though he made considerable progress in classical stu-



One of the Coleoptera (*Cicindela campestris*).

a, Head. b, Thorax. c, Abdomen. d d, Elytra. e e, Wings. f f, Antennæ.

dies, and was known even at that early age as a devourer of metaphysical and theological works. From Christ's Church he went with a scholarship to Jesus College, Cambridge, where he remained for two years, but without achieving much distinction. At this time, too, his ultra-radical and rationalistic opinions made the idea of academic preferment hopeless, and perhaps it was partly to escape the difficulties and perplexities gathering about his future that Coleridge suddenly quitted Cambridge and enlisted in the 15th Dragoons. Rescued by his friends from this position, he took up his residence at Bristol with two congenial spirits, Robert Southey, who had just been obliged to quit Oxford for his Unitarian opinions, and Lovell, a young Quaker. The three conceived the project of emigrating to America, and establishing a pantisocracy as they termed it, or community in which all should be equal, on the banks of the Susquehanna. This scheme, however, never became anything more than a theory, and was finally disposed of when, in 1795, the three friends married three sisters, the Misses Fricket of Bristol. Coleridge about this time started a periodical, the *Watchman*, which did not live beyond the ninth number. In 1796 he took a cottage at Nether Stowey, in Somersetshire, where, soothed and supported by the companionship of Wordsworth, who came to reside at Allfoxden, he wrote much of his best poetry, in particular the *Ancient Mariner* and the first part of *Christabel*. While residing at Nether Stowey he used to officiate in a Unitarian chapel at Taunton, and in 1798 received an invitation to take the charge of a congregation of this denomination at Shrewsbury, where, however, he did nothing further than preach the probation sermon. An annuity bestowed on him by some friends (the Wedgewoods) furnished him with the means of making a tour to Germany, where he studied at the University of Göttingen. In 1800 he returned to England and took up his residence beside Southey at Keswick, while Wordsworth lived at Grasmere in the same neighbourhood. From this fact, and a certain common vein in their poetry, arose the epithet of 'Lake School' applied to their works. About 1804 Coleridge went to Malta to re-establish his health, seriously impaired by opium-eating. In 1806 he returned to England, and after ten years of somewhat desultory literary work as lecturer, contributor to periodicals, &c., Cole-

ridge in a sort took refuge from the world in the house of his friend Mr. Gillman at Highgate, London. Here he passed the rest of his days, holding weekly conversaziones in which he poured himself forth in eloquent monologues, being by general consent one of the most wonderful talkers of the time. His views on religious and political subjects had now become mainly orthodox and conservative, and a great work on the *Logos*, which should reconcile reason and faith, was one of the dreams of his later years. But Coleridge had long been incapable of concentrating his energies on anything, and of the many years he spent in the leisure and quietness of Highgate nothing remains but the *Table Talk* and the fragmentary notes and criticism gathered together, and edited by his nephew, valuable enough of their kind, but less than might have been expected of Coleridge. He died July 25th, 1834. The dreamy and transcendental character of Coleridge's poetry eminently exhibits the man. In his best moments he has a fine sublimity of thought and expression not surpassed by Milton; but he is often turgid and verbose. As a critic, especially of Shakespeare, Coleridge's work is of the highest rank, combining a comprehensive grasp of large critical principles and a singularly subtle insight into details. Coleridge's poetical works include *The Ancient Mariner*, *Christabel* (incomplete), *Remorse*, a tragedy, *Kubla Khan*, a translation of Schiller's *Wallenstein*, &c.; his prose works, *Biographia Literaria*, *The Friend*, *The Statesman's Manual*, *Aids to Reflection*, *On the Constitution of Church and State*, &c. Posthumously were published specimens of his *Table Talk*, *Literary Remains*, &c.

**Coleseed**, a name for a variety of cabbage (*Brassica Napus*) and its seed, which is made into oil-cake for feeding cattle.

**Col'et**, DR. JOHN, an eminent divine, Dean of St. Paul's, and founder of St. Paul's School, London, born 1466, died 1519.

**Colfax**, SCHUYLER, born in New York City, 1823, died at Mankato, Minn., 1885. A Republican statesman, thrice Speaker of the House, Vice-President under Grant, was an accomplished lecturer.

**Colewort**. See *Cabbage*.

**Col'ibri**, a name for various species of humming-bird.

**Co'lic** (from *colon*, a portion of the large intestine), a painful disorder of the bowels, usually of a spasmodic character, unaccompanied by diarrhœa, and presenting itself

in various forms. When the pain is accompanied with a vomiting of bile or with obstinate costiveness it is called a *bilious colic*; if with windy distension, it takes the name of *flatulent* or *windy colic*; if with heat and inflammation, it takes the name of *inflammatory colic*, or *enteritis*. There are many other varieties of this complaint, some of which are peculiar to certain occupations or districts, as the *painters' colic* (see *Lead Poisoning*), the *Devonshire colic*.

**Coligny** (kol-in-yē), GASPARD DE, French admiral, born in 1517, distinguished himself under Francis I. and Henry II., who made him in 1552 Admiral of France. After the death of Henry II. Coligny took the Protestant side in the religious strifes of the time, and became the head of the Huguenot party. He was generally unfortunate in the battles he fought, but speedily repaired his defeats by prudence and good management. When peace was made Coligny was received with apparent favour at court. But this was only a blind; and on the night of St. Bartholomew's (Aug. 24, 1572) Coligny was basely slaughtered, and his corpse given up to the outrages of the mob.

**Colima** (kō-lē'mā), a town of Mexico, capital of the state of same name, situated in a fertile plain encircled by hills above which rises the lofty volcano of Colima. Pop. 1890, 25,124. On the coast about 30 m. s.s.w. of the city is the port, Puerto de Colima, or Manzanillo. The state has an area of 2272 miles; pop. 72,591.

**Colise'um.** See *Colosse'um*.

**Coll**, an island on the west coast of Scotland, off Mull, county Argyre, one of the Hebrides, about 12 miles long and from 3 to 3½ miles broad. A great portion of it is moor, incapable of cultivation; but there are some tracts of light and sandy soil which are tolerably productive. Gaelic is universally spoken. Pop. 643.

**Collat'eral Relations**, descendants of brothers or sisters, or the brothers or sisters of the ascending lines.

**Collateral Security**, additional security, such as a deed granted over other property besides that already mortgaged.

**Collation**, a comparison of one copy or thing of a like kind with another, especially manuscripts and editions of books.—In canon law, the presentation of a clergyman to a benefice by a bishop who has the right of patronage. In such a case the combination of the act of presentation and institution constitute *collation*.

**Col'lect**, a term applied to certain short prayers in the liturgies of various churches. Some of the collects of the English Church are taken from the old Roman Missal, and are supposed to have been written by St. Jerome. Others are still more ancient; while a few have been added after the Reformation. There is a collect for every Sunday in the year, and a corresponding epistle and gospel.

**Col'lege** (Latin, *collegium*), in a general sense, a body or society of persons invested with certain powers and rights, performing certain duties, or engaged in some common employment or pursuit. In Great Britain and America some societies of physicians are called colleges. So, also, there are colleges of surgeons, a college of heralds, &c. The most familiar application of the term college, however, is to a society of persons engaged in the pursuits of literature, including the professors, lecturers, or other officers, and the students. As applied to an educational institution the name is somewhat loosely used. The higher class of colleges are those in which the students engage in study for the purpose of taking a degree in arts, medicine, or other subjects, and are connected with, or have more or less the character of universities. The early history of these institutions is somewhat obscure; the probability is that they were originally founded in the various universities of the middle ages, with similar objects and from the same charitable motives. Hostels or boarding-houses were provided (principally by the religious orders, for the benefit of those of their own fraternity), in which the scholars lived under a certain superintendence, and the endowment of these hostels by charitable persons for the support of poor scholars completed the foundation of a college. Out of this has developed the modern English college as seen at Oxford and Cambridge, where each college, though a member or component part of the university, is a separate establishment whose fellows, tutors, and students live together under a particular head, called *master*, *principal*, *warden*, &c., of the college. In Scotland, America, and Germany the college is practically one with the university, the latter body performing all the functions alike, of teaching, examining, degree-conferring, &c.

**College Point**, Queens co., N. Y., on Long Island Sound, has factories of India-rubber goods, &c. Pop. 1890, 6127.

**College of Justice**, the supreme civil court of Scotland (that is, the Court of Session), composed of the lords of council and session (the judges), together with the advocates (= barristers), clerks of session, writers to the signet, &c.

**Collegiate Church**, in England, a religious house built and endowed for a society or body corporate, a dean or other president, and secular priests, as canons or prebendaries, independently of any cathedral.

**Collie**, a variety of dog especially common in Scotland, and from its intelligence of much use to shepherds. It is of medium size and varies much in colouring, black and white being common, and black with tan-coloured legs, muzzle, &c., being highly esteemed. The head is somewhat fox-shaped, the ears erect, but with drooping points, the tail rather long, bushy, and with a strong curl.

**Col'lier**, JEREMY, English divine and political writer, born in 1650. He was educated at Cambridge, and having entered into orders obtained the rectory of Ampton in Suffolk in 1659. He was a zealous opponent of the Revolution of 1688, and was repeatedly imprisoned for his political writings. He is chiefly remembered now for his *Short View of the Immorality and Profaneness of the English Stage* — a work of considerable merit which is said to have effected a decided reform in the sentiments and language of the theatre. He died in 1726.

**Collier**, JOHN PAYNE, English Shaksperian critic, born in London in 1789, died in 1883. He became known as a critical essayist on old English dramatic literature, and was editor of the new edition of Dodsley's *Old Plays* in 1825. In 1831 his best work, the *History of English Dramatic Poetry*, was published. In 1842–44 he published an annotated edition of Shakspeare in 8 vols.; in 1844 *Shakspeare's Library*. Subsequently he published several editions of Shakspeare, and an excellent edition of Spenser (5 vols. 1862). He made himself notorious by claiming that he possessed a copy of the 2d Folio Shakspeare, 1632, with many marginal emendations and annotations written in the middle of the 17th century, though, as was discovered, these notes were modern fabrications, probably by himself.

**Collimation**, LINE OF, in an astronomical instrument, such as a telescope or transit instrument, the straight line which passes through the centre of the object-glass and

intersects at right angles a system of spider-threads placed at the focus of the eye-piece. The proper adjustment of the line of collimation of the instrument is necessary to accurate observation of the time at which movements of the heavenly bodies take place.

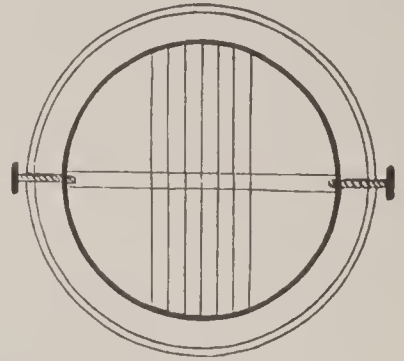

Collimation.

**Collima'tors**, two small subsidiary telescopes used for collimating astronomical instruments, that is, for adjusting the line of collimation, and for determining the collimation error.

**Collin'**. See *Kollin*.

**Col'lingwood**, CUTHBERT, ADMIRAL LORD, English naval commander, born at Newcastle-upon-Tyne in 1750. He entered the royal navy in 1761, and took part as flag-captain on board the *Barfleur* in Lord Howe's victory of June 1, 1794, commanded the *Excellent* during the battle off Cape St. Vincent on the 14th of February in that year, and was made rear-admiral of the white in 1799. But his most distinguished service was at Trafalgar, where his skill and resolution drew warm praise from Nelson. On the latter's death Collingwood as senior officer took command of the fleet, and gave proof of his judgment and nautical skill in his dispositions for the preservation of the captured vessels. For his services here he was elevated to the rank of baron. He died, while cruising off Minorca in the *Ville de Paris*, on 7th March, 1810. Collingwood was the model of a naval officer, combining daring courage with cool judgment, and firm discipline with much humanity. His *Memoirs* and *Correspondence* have been published.

**Col'lins**, ANTHONY, English deistical writer, born 1676, died 1729. He was a friend of Locke, who described him as a man who had 'an estate in the country, a library in town, and friends everywhere.' His chief works are *Discourse of Free Thinking*; *Philosophical Inquiry Concerning Human Liberty*; *Discourse on the Grounds and Reasons of the Christian Religion*; *Literal Scheme of Prophecy Considered*.

**Collins**, WILLIAM, English poet, was born in 1721 at Chichester. While studying at

Oxford he wrote his *Oriental Eclogues*, the moderate success of which encouraged him to try a literary career in London. In 1746 he published his *Odes*, containing pieces which now rank amongst the finest lyrics in the language. Disappointed with the reception his poems met with, and unstrung by irregular habits and excitement, he fell into a nervous melancholy, from which he never quite recovered. He died in 1759.

**Collins, WILLIAM**, an English painter, noted for his landscapes and domestic scenes, born in London Sept. 18, 1787; elected Royal Academician 1820, died 1847.

**Collins, WILLIAM WILKIE**, son of the preceding, born in London in 1824. He was educated for the bar, but turned aside to literature, in which he has specially distinguished himself as a novelist of great dramatic and constructive power. Among his best-known works are *Antonina* (1850), *Basil* (1852), *After Dark* (1856), *The Woman in White* (1860), *The New Magdalen* (1873), *The Evil Genius* (1886), &c. He died in 1889.

**Collision**, in maritime affairs, the shock of two ships coming into violent contact, whereby one or both may suffer more or less injury. Collision may happen without blame being imputable to either party, as where the loss is occasioned by a storm, in which case the misfortune must be borne by the party on whom it happens to light. Or a collision may arise where both parties are to blame—where there has been a want of due diligence or skill on both sides; in which case neither party has an action against the other. Thirdly, it may happen by the misconduct of the suffering party only, and then the rule is that the sufferer must bear his own burden. Lastly, it may have been the fault of the ship which ran the other down; and in that case the injured party would be entitled to an entire compensation from the other. Strict laws and regulations to prevent collisions have been laid down, which contain rules concerning lights, and sailing and steering rules. By the *rule of the road at sea*, if two sailing ships are approaching each other end on, or nearly so, the helms of both must be put to port, so that each may pass on the port side of the other; in crossing so as to involve risk of collision the sailing ship with the wind on the port side shall keep out of the way of the ship with the wind on the starboard, but if they have both the wind on the same side the ship which is to windward shall keep out of the way of the one that has it to leeward. If a

steam-ship and a sailing ship are approaching, so as to involve collision the former must keep out of the way of the latter. If one vessel is overtaking another she must keep out of the way of the last-named vessel.

**Collo'dion**, a substance prepared by dissolving pyroxiline (gun-cotton) in ether, or in a mixture of ether and alcohol, which forms a useful substitute for adhesive plaster in the case of slight wounds. When the fluid solution is applied to the cut or wound it immediately dries into a semi-transparent, tenacious film, which adheres firmly to the part, and under it the wound or abrasion heals without inflammation. In a slightly modified form collodion is also employed as the basis of a photographic process called the *collodion process*. See *Photography*.

**Col'loids**, non-crystallizable substances, such as gelatine, gum, &c. See *Dialysis*.

**Collot d'Herbois** (kol-ō-dār-bwä), JEAN MARIE, French revolutionary, born in 1750. On the outbreak of the revolution he soon became prominent as a leader of the Mountain or extreme party. After filling several missions he was sent by Robespierre along with Fouché to Lyons in 1793, with almost unlimited powers, and was guilty of the most flagrant enormities. Returning to Paris he became a determined opponent of Robespierre, and being chosen president of the Convention (19th July, 1794), contributed to his fall. A few weeks after he was banished to Cayenne, where he died in 1796.

**Collu'sion**, in law, a secret agreement between opposing litigants to obtain a particular judicial decision on a preconcerted statement of facts, whether true or false, to the injury of a third party. Collusion, when proved to exist, nullifies the judgment obtained through it.

**Collyrium** (kol-lir'i-um), an eye-salve or eye-wash, a remedy for disorders of the eyes.

**Col'man, GEORGE**, English dramatic writer and theatrical manager, born at Florence in 1733. Among his pieces are *Polly Honeycombe*, *The Jealous Wife*, and *The Clandestine Marriage*, which was written in conjunction with Garrick. From 1777 he conducted the little theatre in the Haymarket, London, till paralysis rendered him helpless in 1790. He died in 1794.

**Col'man, GEORGE** ('the Younger'), son of the preceding, was born in London in 1762, died there 1836. He was entered as a student in the Temple, but soon left legal studies for dramatic and general literature.

He assisted his father as director of the Haymarket Theatre, and succeeded him as its patentee. Most of his dramas were well received, and some of them still keep the stage, as *John Bull*, the *Heir-at-law*, *Poor Gentleman*, and *Love Laughs at Locksmiths*.

**Col'mar**, or **KOLMAR**, a city of Germany, in Upper Alsace, formerly in the French

department of Haut Rhin, 39 miles s.s.w. Strasburg. It has manufactures of printed goods, calicoes, silks, &c., besides cotton-mills, tanneries, &c. It was united to France in 1697 by the Peace of Ryswick, and surrendered to Germany by the Treaty of Versailles, 26th Feb. 1871. Pop. 26,106.

**Colne** (kōln), a town of England, in the county of and 31 miles s.e. of the town



Cologne, showing Cathedral and Church of St. Martin.

of Lancaster. The chief manufactures are cotton and woollen goods. Population, 1890, 16,774.

**Colne**, a small river in the W. Riding of Yorkshire, giving name to the Colne Valley parl. div.

**Coloca'sia**, a genus of plants, nat. order Araceæ, the leaves and tubers of which are acrid. The latter contain much starchy matter, and they are used as food in the south of Europe after the acrid matter is separated by washing or boiling. *C. esculenta*, *C. macrorhiza*; and others furnish the taro of the Pacific islands. See *Cocco Root*.

**Col'ocynth**, the fruit of *Cucumis* (or *Citrullus*) *Colocynthus*, a species of cucumber, the dried and powdered pulp of which is the colocynth of the shops. It is used in medi-

cine as an aperient. The essential principle, which is of an extremely bitter nature, is called *colocynthine*.

**Colocza**. See *Kalocsa*.

**Cologne** (ko-lōn'), German, *Köln* (kēuln), a city of Rhenish Prussia, on the left bank of the Rhine, forming, in connection with Deutz, which serves as a tête-du-pont on the opposite side of the river (across which is a bridge of boats and an iron railway and general traffic bridge), a fortress of the first rank. The old fortifications, dating from the middle ages, are being, or have been recently, swept away, new works being constructed in accordance with the principles of modern fortification. The town itself has been improved and extended, and streets once dark and filthy have been opened up

or otherwise improved, but Cologne is still irregularly built and largely in the antique style. There are many fine old buildings as well as excellent modern ones; the churches in particular are interesting. The most important edifice of all is the cathedral, begun in 1248, one of the finest and largest Gothic structures in Europe. It was only completed in the present century, there being expended on it in 1828-84 over \$5,000,000. It is in the form of a cross; its entire length is about 445 feet; breadth, 200 ft.; height to ridge of roof, 202 ft.; height of the two western towers, between which is a grand portal, 520 feet, being thus among the highest edifices in the world. The council-house, museum, and Gross St. Martin Church with its imposing tower should also be mentioned. The manufactures embrace sugar, tobacco, glue, carpets, leather, machinery, chemicals, pianos, and the celebrated *eau de Cologne*. The trade by river and railway is very great.—Cologne is of pre-Christian origin, and was originally called *Oppidum Ubiorum*, being the chief town of the Ubii, a German nation. The Romans made it a colony A.D. 51, and called it *Colonia Agrippina* (whence the name *Cologne*). It was annexed to the German Empire in 870, and became one of the most powerful and wealthy cities of the Hanseatic League, but latterly it declined. In 1792 it ceased to be a free city. It was taken by the French in 1794, ceded to them by the Treaty of Lunéville in 1801, and restored to Prussia in 1814. Pop. 281,273.

**Cologne Earth**, a kind of ochre, of a deep-brown colour, transparent, and durable in water-colour painting. It is an earthy variety of lignite or partially fossilized wood.

**Cologne Yellow**, a pigment consisting of 2 parts yellow chromate of lead, 1 of sulphate of lead, and 7 of sulphate of lime or gypsum. It is prepared by precipitating a mixture of nitrate of lead and nitrate of lime with sulphate of soda and chromate of potash.

**Colom'bia**, REPUBLIC OF, formerly called New Granada, a republic of South America, consisting of the nine departments or states of Antioquia, Bolivar, Boyacá, Cauca, Cundinamarca, Magdalena, Panamá (or Istmo), Santander, and Tolima. The population in 1881 was 3,878,600. The chief towns are Bogotá, the capital; Medellín, and Panamá. The territory of the republic includes the whole of the isthmus of Panamá, to the borders of Costa Rica, the Pacific coast

south to Ecuador, and that of the Caribbean Sea east to Venezuela; but there is much disputed boundary territory in the inland regions towards the south and east. The area is estimated officially at 504,773 square miles, but many consider this much too large. According to surface conformation the country may be divided into the elevated region of the Cordilleras in the west, and that of the low-lying lands in the east. The former occupies the greater portion of the country, and presents a richly-diversified surface, being formed chiefly of three mountain chains which stretch north and south in a nearly parallel direction, inclosing between them the valleys of the rivers Cauca and Magdalena. These, the two great navigable rivers of the country, flow northwards, joining their waters about 120 miles from their embouchure in the Caribbean Sea. In the central ridge is the culminating point of Colombia, the volcano of Tolima, 18,315 feet high. The low lands of the east form a transitionary region between the plains of North Brazil and the llanos of the Orinoco region, the drainage being carried to the Amazon and Orinoco. The chief coast indentations are the gulfs of Panamá and Darien. The climate is naturally as varied as the surface of the country, but over a great part of the republic is very hot. At Cartagena, on the Caribbean Sea, and on the Pacific coast, yellow fever is endemic at some places; while on the elevated country, as the plain of Bogotá, 8000 feet above the sea, the climate is perfectly salubrious, and the temperature seems that of eternal spring. The flora is rich and luxuriant. A great part of the country is still covered with virgin forests, which yield excellent building-wood, Peruvian bark, caoutchouc, vanilla, &c. The fauna includes the jaguar, puma, tapir, armadillo, sloth, various species of deer, and the gigantic condor. The mineral wealth is various and abundant, though still imperfectly explored. It comprises coal, gold, silver (both now largely worked by foreign companies), emeralds, and salt. Industry is at a very low stage. Maize, bananas, and plantains are the chief articles of food. Tobacco and coffee are cultivated and exported. Sugar is also grown. Manufactures can scarcely be said to exist, Panamá hats, mats, and coarse cotton cloths being almost the only articles that can be mentioned in this class. The chief ports are Barranquilla, Carthagena, Colon (Aspinwall), and Panamá. The possession of the Isthmus of Panamá



and the small line of railway (48 miles long) which runs between Panamá on the Pacific and Aspinwall on the Atlantic gives Colombia considerable commercial importance which is likely to be increased by the canalization of the isthmus, if this is ever completed. (See *Panamá*.) At present the transit trade across the isthmus is estimated at £17,000,000 per annum. The foreign trade is chiefly with Britain and the United States. The exports are chiefly precious metals, hides, coffee, tobacco, &c.; the imports, manufactured goods. The exports and imports together are usually about £4,000,000 to £5,000,000. There are several short lines of railway. The money standard is the *peso* or dollar, nominal value 4s.—By the constitution, as amended in 1886, the executive power is vested in a president elected for six years, the legislative power in a congress of two houses—the Senate and the House of Representatives. The former consists of 27 representatives, 3 from each department, and 6 members nominated by the president; the latter of representatives elected for four years, one for every 50,000 inhabitants. The revenue is generally under the expenditure and the finances are in an unsatisfactory state. New Granada was discovered by Alonso de Ojeda in 1499; it was visited by Columbus on his fourth voyage, in 1502. The first Spanish settlement was made in 1510 at Santa Maria in the Gulf of Darien, and the whole country was formed into a province under a captain-general in 1547. New Granada declared its independence of Spain in 1811, and after eleven years of warfare succeeded with the help of Venezuela in effecting its liberation. Both states then united with Ecuador, also freed from the Spanish domination, to form the first republic of Colombia; but internal dissensions arising, the three states again separated in 1831, forming three independent republics, which have had a very troubled existence. In 1861 the states forming New Granada by agreement adopted a new constitution, the republic henceforth to be called the United States of Colombia. This title was retained till, by the new constitution adopted in 1886, the state ceased to be a federal republic and became a unitary republic with the name of Republic of Colombia. Its recent history has presented a series of civil broils.

**Colom'bo**, a seaport town, the capital of Ceylon, on the south-west coast, and about 70 miles west by south of Kandy, with

which it is connected by railway. It is a pleasant town with an extensive fort, within which are some of the best houses, and which occupies a projecting point of land. On the north side of the fort, on the margin of the sea, is the Pettah or Black Town, inhabited chiefly by Singhalese, while in the environs are most of the houses occupied by the English. The public buildings comprise the government offices, government house, supreme court, museum, &c. Through the construction of a breakwater and other works there is now excellent harbour accommodation; and numerous vessels call here. Pop. in 1887, 120,000.

**Colom'bo**. See *Calumba*.

**Co'lon** (Gr. *kōlon*), the middle portion of the large intestine, or that which lies between the cæcum and the rectum or terminal portion. In man it is about 4½ feet long, and forms a series of pouches in which the digested food is for a time detained. It is itself believed to have some digestive power.

**Co'lon**, a punctuation mark, thus : used to mark a pause in the sense that might also be indicated by a full stop.

**Colon'**, or **ASPINWALL** (the former is the official name), a free port of Colombia, on Manzanillo Island, on the north side of the Isthmus of Panamá, at the Atlantic extremity of the interoceanic railway, and near that of the Panamá Canal. Established in connection with the railway, it had an important transit trade before the canal was begun, and since then the place has been entirely transformed, a new town with wide and regular streets having been built on a tract of land reclaimed by the Canal Company. There is extensive harbour accommodation. Pop. estimated at 8000 to 10,000.

**Colonel** (*kér'nel*), the commander of a regiment, whether of horse, foot, or artillery. Any rank above a colonel constitutes the bearer of it a general officer. In the British service the rank of colonel is honorary, except in the artillery and engineers, and is usually bestowed upon officers of superior rank and princes of the blood. In the United States army the chief commander of a regiment of troops below a brigadier-general, and above a lieutenant-colonel.

**Colon'na**, an Italian family that had become important as early as the 8th century. Its fame during the middle ages eclipsed that of every other Roman family except the great rival house of the Orsini. The

Colonna family is at present represented by several branches, the Colonna-Sciarra, Colonna-Stigliano, &c. It played an important part in the affairs of Europe, became allied to the greatest houses of Italy, Spain, and Germany, and has furnished many celebrated warriors, popes, and cardinals.

**Colon'na**, CAPE (ancient *Sunium*), the southern extremity of Attica, Greece. Its summit is crowned by the ruins of a temple of Athena 269 feet above the sea, of which sixteen columns of white marble are still standing.

**Colon'na**, VITTORIA, the most renowned poetess of Italy, was the daughter of Fabrizio Colonna, high-constable of Naples, and born in 1490. At the age of seventeen she was married to Ferdinand, Marquis of Pescara, the companion of her youth, who became one of the distinguished men of his age. They lived in the happiest union, and when her husband died of wounds received at the battle of Pavia (1525), Vittoria sought consolation in solitude and in poetry. All her poems were devoted to the memory of her husband. She died at Rome in 1547. Her most celebrated work is the *Rime Spirituali*, 1538. They are considered among the happiest imitations of Petrarca.

**Colonnade'**, in architecture, any series or range of columns placed at certain intervals from each other. When surrounding the building on the exterior the colonnade is called a *peristyle*; when projecting beyond the line of the building it is called a *portico*.

**Col'onsay** and **Or'onsay**, two islands off the west coast of Argyle, Scotland, united at low-water, and at high-water only about 100 yards apart; united length about 12 miles; breadth varying from 1 to 3 miles. Inhabitants engaged in fishing and rearing cattle and sheep. Pop. 387

**Col'ony**, a settlement formed in one country by the inhabitants of another. Colonies may either be formed in dependence on the mother country or in independence. In the latter case the name of colony is retained only in a historical sense. Properly, perhaps, the term should be limited to a settlement which carries on a direct cultivation of the soil, as in the Dominion of Canada or Australia; such settlements as those of the British in Hindustan or Malta being the mere superposition on the natives of a ruling race which takes little or no part in the general industry of the country. The motives which lead to the formation of

colonies, and the manner of their formation, are various. Sometimes the ambition of extending territory and the desire of increasing wealth have been the chief impulses in colonization; but colonies may now be said to have become a necessity for the redundant population of European states. Among ancient nations the principal promoters of colonization were the Phœnicians, the Greeks, and the Romans; the greatest colonizers in modern times have been the English and the Spaniards, next to whom may be reckoned the Portuguese, the Dutch, and the French. The Germans have latterly contributed largely to the tide of emigration, particularly in the direction of America; but they have done little directly as colonizers.

The Phœnician colonies were partly caused by political dissensions and redundant population, but were chiefly commercial, serving as entrepôts and ports of repair for Phœnician commerce along the coasts of Africa and Spain, in the latter of which they numbered, according to Strabo, more than two hundred. But it was in Africa that the most famous arose, Carthage, the greatest colonizing state of the ancient world. The Greek colonies, which were widely spread in Asia Minor and the islands of the Mediterranean, the coasts of Macedonia and Thrace, in South Italy and Sicily, were commonly independent, and frequently soon surpassed the mother states in power and importance. The colonies of Rome were chiefly military, and while the empire lasted were all in strict subordination to the central government. As the Roman power declined the remains of them amalgamated with the peoples among whom they were placed, thus forming in countries where they were sufficiently strong what are known as the Latin races, with languages (Spanish, Portuguese, French, and Italian) which are merely modifications of the old Roman tongue. Before America and the way by sea to the East Indies were discovered, the only colonies belonging to European states were those of the Genoese, Pisans, and Venetians in the Levant and the Black Sea, flourishing establishments on which the mercantile greatness of Italy in those days was largely built.

The *Portuguese* were the first great colonizers among modern states. In 1419 they discovered Madeira, the Azores, and the Cape Verd Islands; the Congo and the Cape of Good Hope followed; and before the cen-

## COLONY.

tury was out Vasco de Gama had landed at Calicut on the Malabar coast of India. The first Portuguese colonies were garrisons along the coasts where they traded: Mozambique and Sofala on the east coast of Africa, Ormuz and Muscat in the Persian Gulf, Goa and Damao on the west coast of India. Colonies were established in Ceylon in 1505, in the Moluccas in 1510. Brazil was discovered in 1499, and this magnificent possession fell to Portugal, and was colonized about 1530. Bad government at home and the subjection of the country to Spain caused the loss of most of the Portuguese colonies. The Portuguese now possess several territories in Asia, at Goa, Damao, and Diu, India; Macao, China; and some islands in the Indian Archipelago. In Africa they possess the Cape Verd and other islands; settlements in Senegambia, Guinea, Mozambique, Sofala, Angola, Benguela, Mossamedes, formally about 700,000 sq. miles.

Soon after the Portuguese the Spaniards commenced the work of colonization. In 1492 Columbus, on board of a Spanish vessel, discovered the island of San Salvador. Hayti, or San Domingo, Porto Rico, Jamaica, and Cuba were soon colonized, and before the middle of the 16th century Mexico, Ecuador, Venezuela, New Granada, Peru, and Chili were subdued, and Spain took the first rank amongst the colonizing powers of Europe. But the Spaniards never really attempted to develop the industrial resources of the subject countries. The pursuit of mining for gold or silver occupied the colonists almost exclusively, and the enslaved natives were driven to work themselves to death in the mines. Cities were founded, at first along the coasts, for the sake of commerce and as military posts; afterwards also in the interior, in particular in the vicinity of the mines, as Vera Cruz, Cumana, Porto Bello, Carthagena, Valencia, Caracas; Acapulco and Panamá, on the coast of the Pacific; Lima, Concepcion, and Buenos Ayres. The colonial intercourse with Spain was confined to the single port of Seville, afterwards to that of Cadiz, from which two squadrons started annually—the *galleons*, about twelve in number, for Porto Bello; and the fleet, of fifteen large vessels, for Vera Cruz. When the power of Spain declined, the colonies soon took the opportunity to declare their independence, and thus were formed the republics of Mexico, Venezuela, Colombia, Ecuador, Peru, Bolivia, Chili, &c. Cuba, Porto Rico, the Philippine Islands,

and the Ladrones were taken by the U. S. during the war of 1898. A portion may be restored, but undoubtedly Spain cannot retain them as formerly. A few small places in India and Africa are all that remain to her.

The hate of Philip II., who prohibited Dutch vessels from the port of Lisbon, forced the *Dutch* to import directly from India or lose the large carrying trade they had acquired. Several companies were soon formed, and in 1602 they were united into one, the Dutch East India Company, with a monopoly of the East India trade and sovereign powers over all conquests and colonies in India. The Dutch now rapidly deprived the Portuguese of nearly all their East Indian territories, settled a colony at the Cape of Good Hope (1650), established a West India Company, made extensive conquests in Brazil (1623-60), which were soon lost, and more permanent ones on some of the smaller West India Islands, as San Eustatia, Curaçoa, Saba, &c. The growing power of the British and the loss of Holland's independence during the Napoleonic wars were heavy blows to the colonial power of the nation. But the Dutch still possess numerous colonies in the East Indies, among which the more important are Java, Sumatra, Dutch Borneo, the Molucca Islands, and part of New Guinea, also several small islands in the West Indies, and Surinam.

No colonizing power of Europe has had a career of such uniform prosperity as *Great Britain*. The English attempts at colonization began nearly at the same time with the Dutch. After many fruitless attempts to find a north-east or north-west passage to the East Indies, English vessels found their way round the Cape of Good Hope to the East Indies in 1591. The East India Company was established in 1600. English commerce with India, however, was not at first important, and they possessed only single factories on the continent up till the beginning of the 18th century. The ruin of the Mogul Empire in India after the death of Aurengzebe (1707) afforded the opportunity for the growth of British power, as the British and French were compelled to interfere in the contentions of the native princes and governors. The French appeared at first to maintain the superiority; but the British in turn got the upper hand, and the victory of Clive at Plassey in 1756 laid the foundation of an exclusive British sovereignty in India.

## COLONY.

By the middle of the next century the British territory embraced, with the exception of a few dependent states, nearly the whole of India, and this vast territory was still under the government of the East India Company—a mercantile company, controlled indeed by parliament, but exercising many important functions of sovereignty.

The discoveries of the Cabots, following soon after the voyages of Columbus, gave the English crown a claim to North America, which, though allowed to lie dormant for nearly a century, was never relinquished, and which, in the reign of Elizabeth, led to colonization on a large scale. Raleigh's settlement on Roanoke Island (N. Carolina) in 1585 failed to become permanent, but in 1607 the colonists sent out by the London Company to Chesapeake Bay founded Jamestown, on the James River, in Virginia. The next great settlement was that of the Pilgrim Fathers, who landed 21st Dec. 1620, in Massachusetts Bay. The colonization of New Hampshire, Maine, New Jersey, Connecticut, Rhode Island, soon followed. In the State of New York and the Hudson River Territory the British found the Dutch already in possession; but in 1634 they seized the colony of New Amsterdam by force, changing its name to New York in honour of James, Duke of York. Pennsylvania was founded by William Penn, and colonized with Quakers in 1682; Maryland in 1631 by a party from Virginia; Carolina in 1670 and Georgia in 1732 by colonies from England. Colonies were early established in the West India Islands, including Barbadoes, half of St. Christopher's (1625), and soon after many smaller islands. Newfoundland was taken possession of in 1583, colonized in 1621 and 1633. Canada was surrendered to Britain at the Peace of Paris in 1763. In 1764 began the disputes between Britain and its North American colonies, which terminated with the acknowledgment of the independence of the United States, Canada still remaining a British dependency.

Australia was discovered in the beginning of the 17th century. The first Australasian settlements of Britain were penal colonies. New South Wales, discovered in 1770, was established as a penal colony in 1788; Tasmania (Van Diemen's Land), discovered by Tasman in 1642, followed in 1803; West Australia, also first used as a penal settlement, became a free colony in 1829; Victoria (Port Philip) was colonized in 1835,

and made an independent colony under its present name in 1851; South Australia was settled in 1836; New Zealand, discovered by Tasman in 1642, began to be used for whaling about 1790, was settled in 1839, and made a colony in 1840. In 1851 the discovery of the abundance of gold in Victoria gave a great impetus to the prosperity of the Australian colonies. In 1874 the Fiji Islands, and in 1884 part of New Guinea, were annexed as crown colonies. In South Africa Cape Colony, first settled by the Dutch in 1652, became an English colony in 1814. The latest annexations in this quarter are Griqualand West (1880), the Transkeian Territories (1875-84), Walfisch Bay (1884), and Bechuanaland (1885). Further north are the crown colonies—Lagos, the Niger Districts, the Gold Coast, Gambia, and Sierra Leone—all, except Lagos, which was acquired in 1861, ancient possessions of the British crown. In Europe Great Britain has a few colonies acquired for military reasons—Gibraltar in 1704, Malta and Gozzo 1800, Cyprus, 1871; and has practically made a colony of Egypt and is now (1898) taking final steps for the subjugation of the Soudan, having defeated the Mahdi at Berber and about to take Khartoum in Oct. '98.

It is estimated that the existing British colonies and dependencies embrace about one-sixth of the land surface of the globe and nearly the same proportion of its population. See *Britain*.

According to their government relations with the crown the colonies are arranged under three heads:—(1.) Crown colonies, in which the crown has the entire control of legislation, while the administration is carried on by public officers under the control of the home government. (2.) Colonies possessing representative institutions but not responsible government, in which the crown has no more than a veto on legislation, but the home government retains the control of public officers. (3.) Colonies possessing representative institutions and responsible government, in which the crown has only a veto on legislation, and the home government has no control over any officer except the governor. All colonies are, however, disabled from such acts of independent sovereignty as the initiative in war, alliances, and diplomacy generally.

France was somewhat late in establishing colonies. Between 1627 and 1636 the West Indian islands of St. Christopher's, Guadeloupe, and Martinique were colonized by

private persons. Champlain was the pioneer of the French in the exploration of the North American continent, and founded Quebec in 1608. Colbert purchased several West India islands, as Martinique, Guadeloupe, St. Lucia, &c., and sent out colonists in 1664 to Cayenne. In 1670 the East India Company formed by Colbert founded Pondicherry, which became the capital of extensive possessions in the East Indies. At the beginning of the 18th century France had extensive settlements in Canada, Nova Scotia, and Newfoundland, the most flourishing of the West India islands, and she seemed to have a prosperous career before her in India. Ere long, however, the rival interests of British and French colonists brought about a conflict which terminated in the loss of Canada and other North American possessions, as well as many of the West India Islands, while the dominion of India passed into the hands of the British. The chief colonial possessions of France at present are: in India, Pondicherry, and a few other small territories; Cochin China, Tonquin, and the protectorates of Annam and Cambodia in S. Eastern Asia; New Caledonia, the Loyalty and Marquesas Islands, &c., in Oceania; in Africa, Algeria, Tunis, Senegambia, island of Réunion, the protectorate of Madagascar, &c.; in America, Martinique, Guadeloupe, St. Bartholomew, and Guyana. Algeria is now officially a French department.

Of recent years *Germany* has made an effort to take rank as a colonial power, and has acquired in Africa the territories of Damaraland and Luderitzland to the northward of Cape Colony, the Cameroons District, a considerable portion of territory formerly claimed by the Sultan of Zanzibar, the Kilima-Njaro, the greater part of Somaliland, &c.; also in the Pacific a portion of New Guinea, now called Kaiser Wilhelm's Land, and the Bismarck Archipelago. *Denmark's* northern dependencies, Iceland, Greenland, and the Faroe Islands, though of considerable extent are of small value. In the West India Islands she has St. Thomas, settled in 1672; Santa Cruz, purchased from France in 1733; St. John; and some smaller islands.

**Col'ophon**, an ancient Ionian (Greek) city of Asia Minor about eight miles north of Ephesus, one of the places that claimed to be the birthplace of Homer, and the native city of Mimnermus, the elegiac poet, and of other eminent men.

**Col'ophon**, the device or imprint at the end of a published work, which in old books frequently stated the name of the author as well as the printer's name, along with the date and place of publication, most of which information is now put in the title-page.

**Col'ophony**, the dark resin obtained by distilling turpentine.

**Colorado** (kol-o-rä'dō), one of the United States of America, situated in the central belt of states in the Rocky Mountains, between lat. 37° and 41° N., and lon. 102° and 109° W., and containing an area of 103,925 sq. miles. The western and central portions of its area are occupied by an intricate plexus of wild and irregular ranges inclosing valleys known as 'parks,' most of which are fertile, well wooded, and of a mild climate. These 'parks' are apparently the basins of former lakes upheaved and deprived of their waters by volcanic agency, with their original shape and situation at the foot of high mountains undisturbed, while their lowest depths are from 6000 to 9000 feet above the level of the sea. A large number of the mountains are over 14,000 feet high, including Pike's Peak, Long's Peak, and others. The east of the state is a vast plain well adapted for pasture. The rivers include the Arkansas, S. Platte, Grand River, &c.; many of them remarkable for the grandeur of their cañons. Among wild animals are the grizzly, the black and brown bear, prairie-wolf, buffalo, several kinds of deer, big-horn sheep, &c. There are extensive forests. Of the arable lands in the state a great portion require irrigation. Grasshoppers sometimes commit great ravages. The climate is dry and healthy. The chief wealth of Colorado consists of its minerals, principally gold and silver. From the discovery of gold in 1858 up to 1887 the yield was about \$55,000,000, that of silver about half as much; but silver is now produced to a greater value than gold, over \$15,000,000 of silver having been raised in 1886. Iron is pretty widely diffused, and coal is found extensively. There is an extensive series of railways. The public school system is good, and there is a state university. Colorado was little known previous to 1859; it was organized as a territory in 1861, and admitted as a state in 1876. The state capital is Denver, which in 1870 had a population of 4759, and in 1890, 106,713. Leadville is the next in importance. Pop. of the state in 1870, 39,864; in 1880, 194,327; in 1885, 244,000; in 1890, 412,198.

**Colorado**, a name of two rivers of the U. States.—(1) The WESTERN COLORADO, or RIO COLORADO, formed by the junction of the Green and Grand Rivers, at about lat. 38° N.; lon. 110° W., in Utah. It flows south-west and south through Arizona, and between Arizona and Nevada and California, and after a total course, including Green River, of about 1200 miles, falls into the Gulf of California. Among the most wonderful natural objects in North America is the Big Cañon of the Colorado, between lon. 112° and 115° W. Here the river flows between walls of rock which are nearly vertical, and are in some places 6000 feet high. This cañon is more than 300 miles long. (2) A river in Texas which rises in the north-west part of the state, flows generally south-east, and after a course of about 900 miles falls into the Gulf of Mexico at the town of Matagordo.

**Colorado Beetle**, an American species of beetle (*Chrysomēla*, or *Polygramma*, or *Doryphōra decemlineāta*), nearly half an inch in length, almost oval, of a yellowish colour

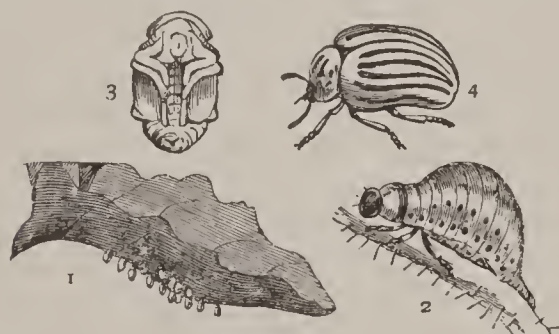

Colorado Beetle (*Chrysomēla decemlineāta*).

1, Part of leaf with eggs of the insect. 2, Caterpillar. 3, Pupa. 4, Perfect insect. (All nat. size.)

marked with black spots and blotches, and on the elytra with ten black longitudinal stripes. The wings are of a blood-red colour. It works great havoc among the potato crops.

**Colorado Springs**, El Paso co., Col., 75 m. S. of Denver; a delightful climate and a pleasant summer resort. Pop. 11,140.

**Colorim'eter**, an instrument for measuring the depth of colour in a liquid by comparison with a standard liquid of the same tint.

**Colos'sæ**, an ancient city of Asia Minor, in Phrygia, on the Lycus, a branch of the Mæander. It was the seat of one of the early churches of Asia to whom the apostle Paul wrote about 62 or 63 A.D. See *Colos'sians*.

**Colosse'um**, a name given to the Flavian Amphitheatre in Rome, a large edifice for

gladiatorial combats, fights of wild beasts, and similar sports. It was begun by Vespasian, and finished by Titus 80 A.D. The outline of the Colosseum is elliptic, the exterior length of the building being 620 and its breadth 513 feet; it is pierced with eighty openings or vomitaria in the ground story, over which are superimposed three other stories, the whole rising perpendicularly to the height of 160 feet. Although two-thirds of the original building have disappeared it is still a wonderful structure.

**Colos'sians**, EPISTLE TO THE, was written to the Colossians by the apostle Paul either from Rome or Cæsarea, at the same time that he wrote the epistles to the Ephesians and to Philemon. The epistle contains a summary of Christian doctrine, especially dwelling on the divine power and majesty of Christ, and a series of practical exhortations to specific duties of Christian morality.

**Colos'sus**, in sculpture, a statue of enormous magnitude. The Asiatics, the Egyptians, and in particular the Greeks, have excelled in these works. The most celebrated Egyptian colossus was the vocal statue of Memnon in the plain of Thebes, supposed to be identical with the most northerly of two existing colossi (60 ft. high) on the west bank of the Nile. Among the colossi of Greece the most celebrated was the Colossus of Rhodes, a brass statue of Apollo 70 cubits high, esteemed one of the wonders of the world, erected at the port of Rhodes by Chares, 290 or 288 B.C. It was thrown down by an earthquake about 224 B.C. The statue was in ruins for nearly nine centuries, when the Saracens, taking Rhodes, sold the metal, weighing 720,900 lbs., to a Jew, about 653. There is no authority for the popularly-received statement that it bestrode the harbour mouth, and that the Rhodian vessels could pass under its legs. Among the colossi of Phidias were the Olympian Zeus and the Athena of the Parthenon; the former 60 ft. high and the latter 40. The most famous of the Roman colossi were the Jupiter of the Capitol, the Apollo of the Palatine Library, and the statue of Nero, 110 or 120 ft. high, and from which the contiguous amphitheatre derived its name of Colosseum. Recently rock-cut statues have been measured at Bamian on the road between Cabul and Balkh, the largest being 173 ft. high and the second 120 ft.

Among modern works of this nature is the colossus of San Carlo Borromeo, at

Arona, in the Milanese territory, 60 ft. in height; the 'Bavaria' at Munich, 65 ft. high; the statue of Hermann or Arminius near Detmold, erected in 1875, 90 ft. in height to the point of the upraised sword, which itself is 24 ft. in length; the height of the figure to the point of the helmet being 55 ft.; the statue of Germania, erected in 1883 near Rudesheim, a figure 34 ft. high, placed on an elaborately-sculptured pedestal over 81 ft. high; and Bartholdi's statue of Liberty presented to the U. States by the French nation, and which measures 104 ft., or to the extremity of the torch in the hand of the figure 138 ft. It is erected at New York harbour on a pedestal 114 ft., is constructed for a lighthouse with one of the most powerful fixed lights in the world, and stands 317 ft. above mean tide.

**Colos'trum**, the first milk of mammalia secreted after giving birth to young. It differs in composition from ordinary milk; has a purgative action, and serves to clear the bowels of infants of the meconium or fæcal matter which they contain at birth.

**Colour** is the name given to distinguish the various sensations that lights of various rates of vibration give to the eye. As is the case with many of the words that denote our sensations, the word *colour* is also applied to the properties of bodies that cause them to emit the light that thus affects our senses. The molecular constitution of a body determines the character and number of the light vibrations it returns to the eye, and so gives to each body its own characteristic colour; hence the term colour is used to denote that in respect of which bodies have a different appearance to the eye independently of their form.

Ordinary white light (the light which comes from an incandescent solid or liquid) when transmitted through triangular prisms of glass or other media differing in dispersive power from the atmosphere, is shown to consist of a number of coloured lights, which, meeting the eye, together produce the sensation of white light. (See *Spectrum* and *Light*.) The colours thus shown are usually said to be seven—red, orange, yellow, green, blue, indigo, violet; although in reality there is an enormous, if not an infinite number of perfectly distinct colours in light. The seven colours are frequently called the primary colours, and other tints and shades are producible by mixing them; but in a stricter sense the primary colours are three in number, namely, red, green, and

violet (or blue). These three colours or kinds of light cannot be resolved into any others. In the scientific sense of the word white and black are not considered colours, a white body reflecting and a black body absorbing all the rays of light without separating them, whereas the colours proper are due to separation of the rays of light by partial absorption and reflection or by refraction. If a body absorbs every other kind of light and reflects or transmits red light only, it will appear of a red colour; if it absorbs every kind except blue rays, it will appear blue; and so on. If more than one kind of light be transmitted or reflected the object will appear of a colour compounded of these different rays of light.

In art the term colour is applied to that combination or modification of tints which produces a particular and desired effect in painting. The colours of the spectrum have to be distinguished from colour used in reference to *pigments*. The pigments red, blue, and yellow, regarded in the arts as the primary colours, produce effects, when mixed, very different from those produced by admixture of the corresponding spectrum colours. These three pigment colours form other colours thus: red and yellow make orange, yellow and blue make green, and red and blue make purple; but red, blue, and yellow cannot be produced by any combination of the other colours.—*Local colours* are those which are natural to a particular object in a picture, and by which it is distinguished from other objects.—*Neutral colours*, those in which the hue is broken by partaking of the reflected colours of the objects which surround them.—*Positive colours*, those which are unbroken by such accidents as affect neutral objects.—*Complementary colours*, colours which together make white; thus any of the primary colours is complementary to the other two.—*Subjective* or *accidental colours*, the imaginary complementary colours seen after fixing the eye for a short time on a bright-coloured object, and then turning it suddenly to a white or light-coloured surface.

Colours in heraldry are *azure*, blue; *gules*, red; *sable*, black; *vert*, green; *purpure*, purple; *tenné* or *tawny*, orange; and *murrey* or *sanguine*, dark crimson. (See *Heraldry*.) Military colours are the flags or ensigns of a regiment. See *Colours (Military)*.

**Colour-blindness**, total or partial incapability of distinguishing colours. Colour-blindness has been divided into three grades:

(a) Inability to discern any colour, so that light and shade, or black and white, are the only variations perceived. (b) Inability to distinguish the nicer shades of the more composite colours, as browns, grays, and neutral tints. (c) Inability to distinguish between the primary colours, red, blue, and yellow, or between them and their secondaries, green, purple, orange, and brown. Red is the colour which the colour-blind are most commonly unable to distinguish, while yellow is the most easily recognized. Colour-blindness occurs in eyes whose power of vision, as to form and distance, is quite perfect, and may exist unknown to the person affected by it. This defect is common especially among men. The cause of it in almost every case which has been carefully investigated, has been found to be seated in the sensorium, not in the visual apparatus. It will be easily understood that those whose eyesight is thus defective are disqualified for holding various positions.

**Colour Printing**, the art of producing pictures, designs, cards, &c., in various colours by means of lithography, printing from metal blocks, &c. The ordinary methods are: (1) the chromo-lithographic, in which a tracing of the original picture, or the like, is first made, and a copy transferred to as many stones as there are colours in the original, every colour requiring a fresh stone. The drawing on each stone is made to fit in, or *register*, with the preceding one, and as the paper passes through the machine an additional colour is added every time, and thus the picture is built up colour upon colour (each being allowed to dry before the next is put on) until it is completed. Some chromos or oleographs may have as many as 25 or 30 printings or colours. (2) Block or surface colour printing is specially adapted for book illustrations or similar work where nicety of detail or rapidity of production is required. As in chromo-lithography various printings are necessary; but these, while producing similar effects, are reduced in number by a method of printing several tints of the same colour at one operation. Each block, which is usually of zinc and prepared in the usual way, is capable of producing three or more gradations of the same colour; the darkest shade from the normal surface, lighter shades being got from parts which have been bitten or corroded in an almost imperceptible degree—the deeper corrosions giving, of course, the lightest shade. When all the tints of

one colour are thus printed from one block and at one operation, a second block with gradations, in the same way, is used, registering as in chromo-lithography, and so on until the picture is finished.

**Colours, MILITARY**, the banners or flags of regiments of infantry, on which are borne the devices, distinctions, badge and motto of the regiment, and its number, in gold characters. The colours of a regiment are always saluted with the utmost respect by a guard, and it is customary for officers on the staff to salute colours when they are borne past at a review. The banners of regiments of dragoons are called *guidons*, and those of other cavalry regiments *standards*. To capture the colours of a regiment in battle is regarded as an honourable feat.

**Colour-sergeant**, a non-commissioned officer who ranks higher and receives better pay than an ordinary sergeant, and who, in addition to discharging all the ordinary duties of a sergeant, attends the colours in the field or near head-quarters. There is one colour-sergeant to each regiment of infantry, or brigade of artillery.

**Colporteur** (*kol-por-teur'*), a French term now naturalized in U. States, and appropriated to a class of men always, or most commonly, subsidized by societies or associations with the view of disseminating religious literature by carrying about publications for sale, generally at reduced rates.

**Colton**, CHARLES CALEB, English writer, born 1780, died by his own hand at Fontainebleau 1832. He held the united living of Kew and Petersham, but was eccentric in his manners, extravagant in his habits, and irremediably addicted to gambling and its attendant vices. Bewildered by his pecuniary obligations he fled to the United States, and after a sojourn there of some years took up his abode in Paris, where he acquired a fortune of \$125,000 by gambling, which was soon dissipated. Through apprehension of a surgical operation he committed suicide. He wrote several satirical poems, Hypocrisy, Napoleon, &c.; but his most remarkable work is *Lacon*; or, *Many Things in Few Words*.

**Colt's-foot**, *Tussilāgo Farfāra*, a weed of the order Compositæ, the leaves of which were once much employed as a remedy for asthma and coughs. The name is given from the leaf somewhat resembling the foot of a colt, being broad and heart-shaped; the flowers are yellow.



## COLT'S REVOLVER — COLUMBIAN EXPOSITION.

**Colt's Revolver.** See *Revolver*.

**Col'uber**, a genus of non-venomous serpents, which includes, besides several N. American snakes, the *Coluber Æsculapii*, common in the neighbourhood of Rome, and regarded as the serpent which was sacred to Æsculapius, the god of medicine. To the same family belongs the common ringed snake of Britain (*Tropidonotus natrix*), which attains a length of 3 or 4 feet.

**Colum'ba.** See *Calumba*.

**Colum'ba, St.**, a native of Ireland (Gar-tan in Donegal), born 521, died at Iona 597. In 545 he founded the monastery of Derry, and subsequently established many churches in Ireland. About 563 he landed in the island of Hy, now called Iona, and founded his church. About 565 he went on a mission of conversion among the northern Picts, and traversed the whole of Northern Scotland preaching the Christian faith and founding monasteries, all of which he made subject to that which he had set up on the island of Hy. The Columban church was in some points of doctrine and ceremonial opposed to that of Rome, to which it owed no allegiance. Shortly before his death he revisited Ireland. There is a well-known life of St. Columba, *Vita Sancti Columbæ*, written by St. Adamnan, abbot of Iona.

**Columba'nus, SAINT, or SAINT COLUMBAN**, a missionary and reformer of monastic life, born in Ireland apparently about 540, became a monk in the Irish monastery of Benchor (Bangor), went through England to France with twelve other monks to preach Christianity, and founded the monasteries of Annegray, Luxeuil (590), and Fontaine in Burgundy. His rule, which was adopted in latter times by many monasteries in France, commands blind obedience, silence, fasting, prayers and labour, much more severe than the Benedictine rule, and punishes the smallest offences of the monks with stripes. He retained also the old ecclesiastical customs of the Irish, among which is the celebration of Easter at a different time from the Roman Church. He appears to have remained at Luxeuil for nearly twenty years. He then went among the heathen Alemanni, and preached Christianity in Switzerland. About 612 he passed into Lombardy, and founded the monastery of Bobbio, in which he died in 615. His writings comprise his monastic rule, sermons, some poems and ecclesiastical treatises. His Life was written by Abbot Jonas, a successor in the abbacy of Bobbio.

**Columba'rium**, in Roman antiquities, a place of sepulture for the ashes of the dead after the custom of burning the dead had been introduced. Columbaria consisted of arched and square-headed recesses formed in walls in which the cinerary urns were deposited, and were so named from the resemblance between these recesses and those formed for the doves to build their nests in in a dove-cot.

**Colum'bia**, the capital of South Carolina, situated on an elevated plain on the left bank of the Congaree. It is regularly laid out, and contains some fine public buildings, including the state-house. Among the educational institutions are the South Carolina University, founded in 1804, and a Presbyterian theological college. Pop. 1890, 15,353.

**Columbia**, a city of the U. States, in Pennsylvania, on the Susquehanna, a great mart for lumber. Pop. 1890, 10,597.

**Columbia**, Murray co., Tenn., on Duck River. Pop. 1890, 5370.

**Columbia, DISTRICT OF**, a small tract of country in the U. States, on the Potomac, about 120 miles from its mouth, surrounded on three sides by Maryland, forming a neutral district for the seat of the national government. It has an area of 64 square miles; was formed into a territory in 1871; and contains the cities of Washington and Georgetown, the former of which has been the national capital since 1800. The affairs of the district and of Washington are administered by three commissioners directly under Congress. Pop. 230,392.

**Columbia College**, a distinguished educational institution in New York, established in 1746, and giving a course of instruction in literature, divinity, science, medicine, law, and mining.

**Columbia River, or OREGON**, a river in N. America, flowing into the Pacific Ocean, and rising at the base of the Rocky Mountains in British Columbia. It has a very winding course partly in British Columbia but mainly in the U. States, where it receives two large tributaries, Clark's River and Snake River. Latterly it turns abruptly to the west and forms the boundary between the states of Washington and Oregon. It drains an area of 298,000 square miles, and has a length of about 1400 miles.

**Columbian Exposition**, created by act of Congress of April 25, 1890, providing for celebrating the 400th anniversary of the discovery of America by Columbus.

by holding an international exhibition of arts, industries, manufactures, &c., in Chicago, Ill. Oct. 12, 1892, the President and State Governors, and prominent civil and military dignitaries, participate in imposing ceremonials, dedicating the grounds and buildings. The estimated cost of the buildings, &c., was over \$33,000,000. An invitation to participate extended to foreign nations was responded to in a friendly way. There were special State exhibits.

**Columbus**, Bartholomew co., Indiana, in midst of a rich agricultural region; has various factories. Pop. 1890, 6719.

**Columbus**, a city of the U. States, the capital of Ohio, in Franklin county, on the east bank of the Scioto, near the centre of the state. It contains some notable public buildings. The capitol is second in size only to that of Washington, and is built of gray limestone in the simple Doric style. Other buildings are the deaf and dumb institution, institution for the blind, lunatic asylum, penitentiary, R. Catholic cathedral, &c. Educational institutions include the state university, Columbus medical college, Starling medical college, &c. There is a very extensive trade, and the manufactures are important and varied. Pop. 88,150.

**Columbus**, a town in the United States, in Georgia, on the Chattahoochee River, well built, with cotton and other manufactures. Pop. 1890, 17,303.

**Columbus**, CHRISTOPHER (in Spanish, *Christoval Colon*; in Italian, *Cristoforo Colombo*, which is his real name), was born in Genoese territory in 1435 or 1436, died at Valladolid, Spain, 1506. His father, Domenico Colombo, a poor wool-comber, gave him a careful education. He appears to have gone to sea at an early age and to have navigated all parts of the Mediterranean and some of the coasts beyond the Straits of Gibraltar. In 1470 we find him at Lisbon, where he married the daughter of Bartolommeo de Palestrello, a distinguished navigator. He had gradually come to the conclusion that there were unknown lands belonging to Eastern Asia separated from Europe by the Atlantic: whilst the Portuguese were seeking to reach India by a south-east course round Africa he was convinced that there must be a shorter way by the west. He applied in vain to Genoa for assistance, and equally fruitless were his endeavours to interest John II. of Portugal in the enterprise. He then determined to apply

to the Spanish court; and after many disappointments he induced Ferdinand and Isabella to equip and man three vessels for a voyage of discovery. It was early in the morning of Friday, on the 3d of August, 1492, that Columbus set sail from the port of Palos, and after sailing for two months



Columbus.

the expedition narrowly escaped failure. The variation of the needle so alarmed the crews that they were on the point of breaking out into open mutiny, and he was obliged to promise that he would turn back if three more days brought no discovery. On the third day (12th Oct. 1492) the island of Guanahani or San Salvador was sighted, which Columbus believed to belong to Eastern Asia and to be connected with India—a belief which he carried with him to his grave. Hence the mistaken name of *Indians* applied to the natives of America, and that of *West Indies* applied to the group of islands of which Guanahani forms one. On landing Columbus threw himself upon his knees and kissed the earth, returning thanks to God. The natives collected round him in silent astonishment, and his men, ashamed of their disobedience and distrust, threw themselves at his feet, begging his forgiveness. Columbus, drawing his sword, planted the royal standard, and in the name of his sovereigns took possession of the country, which, in memory of his preservation, he called *San Salvador*. He then sailed in search of other lands, and discovered Cuba, St. Domingo, and some other of the West India islands. Being so far successful, he built a fort at Hispaniola, Hayti, left some of his men there, and set out on his return to Europe, where he was received with almost royal honours. In 1493 he set out on his

second great voyage from Cadiz, with three large ships of heavy burden and fourteen caravels, carrying 1500 men. He discovered the island of Dominica, and afterwards Mariagalante, Guadeloupe, and Porto Rico, and at length arrived at Hispaniola. Finding the colony destroyed, he built a fortified town, which he called, in honour of the queen, *Isabella*. He then left the island in order to make new discoveries, visited Jamaica, and returning after a voyage of five months, worn down with fatigue, found to his great joy that his brother Bartolommeo had arrived at Isabella with provisions and other supplies for the colony. Meanwhile a general dissatisfaction had broken out among his companions, who, instead of the expected treasures, had found hardships and labour. This and news of calumnies being set on foot against him at home induced him to return to Spain, where his presence, and probably also the treasure he brought, silenced his enemies. In May, 1498, he sailed with six vessels on his third voyage. Three of his vessels he sent direct to Hispaniola; with the three others he took a more southerly direction, and having discovered Trinidad and the continent of America, returned to Hispaniola. His colony had now been removed from Isabella, according to his orders, to the other side of the island, and a new fortress erected called St. Domingo. Columbus found the colony in a state of confusion, but soon restored tranquillity. His enemies, in the meantime, endeavoured to convince his sovereigns that his plan was to make himself independent, and Columbus was not only displaced, but Francisco de Bobadilla, a new governor who had come from Spain, even sent him to that country in chains. On his arrival (in 1500) orders were sent directing him to be set at liberty and inviting him to court, but for this injurious treatment he never got redress, though great promises were made. After some time he was able to set out on his fourth and last voyage (1502) in four slender vessels supplied by the court. In this expedition he was accompanied by his brother Bartolommeo and his son Hernando. He encountered every imaginable disaster from storms and shipwreck, and returned to Spain, sick and exhausted, in 1504. The death of the queen soon followed, and he urged in vain on Ferdinand the fulfilment of his promises; but after two years of illness, humiliations, and despondency, Columbus died at Valladolid. His remains were transported, according to

his will, to the city of St. Domingo, but on the cession of Hispaniola to the French they were removed in January, 1796, to the cathedral of Havannah in Cuba.

**Columel'la**, LUCIUS JUNIUS MODERATUS, Roman writer on agriculture; born at Cadiz in Spain; lived about the middle of the first century after Christ, and wrote twelve books which are still extant, one of which, on gardening (*De Re Rustica*), is in verse.

**Column** (Latin, *columna*), in architecture,

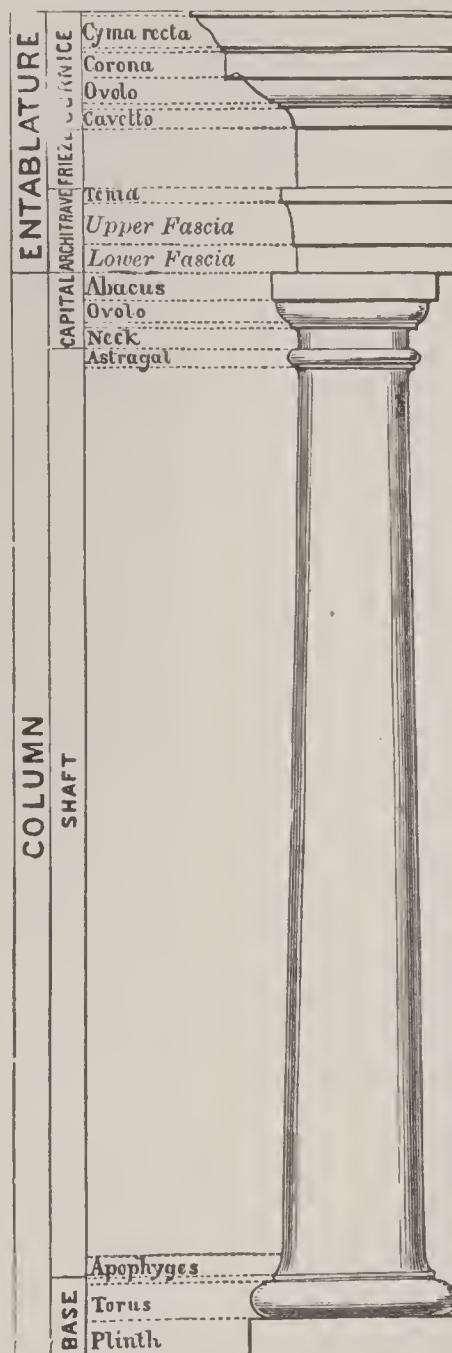

Column (Tuscan order), illustrating the terms applied to the several parts.

a round pillar, a cylindrical solid body set upright and primarily intended to support some superincumbent weight. A column has as its most essential portion a long solid

body, called a *shaft*, set vertically on a *stylobate*, or on a congeries of mouldings which forms its *base*, the shaft being surmounted by a more or less bulky mass which forms its *capital*. In classical architecture columns have commonly to support an *entablature* consisting of three divisions, the *architrave*, *frieze*, and *cornice*, adorned with mouldings, &c. The accompanying cut will illustrate these and other terms. Columns are distinguished by the names of the styles of architecture to which they belong; thus there are Hindu, Egyptian, Grecian, Roman, and Gothic columns. In classic architecture they are further distinguished by the name of the order to which they belong, as Doric, Ionic, Corinthian, Composite or Tuscan columns. They may also be characterized by some peculiarity of position, of construction, of form, or of ornament, as attached, twisted, cabled, &c., columns. Columns are chiefly used in the construction or adornment of buildings. They have also been used, however, singly for various purposes, especially for monuments. See *Corinthian*, *Doric*, *Ionic*, *Gothic*, &c.

**Column**, in military tactics, a formation of troops drawn up in deep files, showing a small front; as distinguished from *line*, which is extended in front and thin in depth. They are said to be close or open, according to the intervals between the battalions, regiments, &c., of which they are composed. Sometimes the name column is given to a small army, especially when actively engaged.

**Col'ure**, in astron., one of two great circles which divide the ecliptic into four equal parts. One passes through the solstitial and the other through the equinoctial points of the ecliptic.

**Colym'bus**, the diver genus of birds, giving name to the family Colymbidæ, which includes also the Grebes.

**Colza Oil**, an oil much employed for burning in lamps, and for many other purposes. It is expressed from the seeds of *Brassica campestris oleifera*, and from allied plants of the cabbage family. It is yellowish-brown, and has little or no smell. It becomes thick and solid only at very low temperatures.

**Coma**, in medicine, a state of complete insensibility, resulting from various diseases, as apoplexy; from narcotics, as opium; from accident or injury to the brain; or from excessive cold.

**Coma**, the luminous, nebulous, hairlike

substance surrounding the nucleus of a comet.

**Coma Berenices**, BERENICE'S HAIR, a small constellation of the northern hemisphere containing about forty stars visible to the naked eye, situated between Boötes and the tail of Leo.

**Comacchio** (ko-mak'ki-ō), a fortified town, Italy, province of Ferrara, amidst unhealthy marshes, about 2 miles from the Adriatic, with productive fisheries. It is the seat of a bishopric. Pop. 7630.

**Coma'na**, an ancient city of Cappadocia, celebrated in antiquity as the seat of the solemn worship of Ma (the moon goddess). Its site has not been identified.

**Comanches** (kō-man'chez), an American Indian tribe formerly roaming through Texas and part of Mexico. They were excellent horsemen, and extremely warlike, but their numbers are now insignificant. Some of them have been collected on a reservation in the western part of the U. States Indian Territory.

**Comayagua** (kō-mā-yä'gwá), a town of Central America, in Honduras, the capital of department of the same name, situated on the southern border of the plateau of Comayagua, about midway between the two oceans; a poor place. Pop. about 10,000.

**Comb**, an instrument with teeth, made of tortoise-shell, ivory, horn, wood, bone, metal, or other material, used for dressing the hair, and by women for keeping the hair in its place when dressed. Combs have been used from the earliest times by rude as well as by civilized races.

**Combaco'num**, a town of Hindustan, presidency of Madras, district of Tanjore. It was the ancient capital of the Chola dynasty, and is one of the most ancient and sacred towns in the presidency. It has a great many well-endowed Hindu temples, a government college, courts, &c. A brisk trade is carried on with visitors and pilgrims. Pop. 1891, 54,307.

**Combat**, TRIAL BY. See *Battle*, *Wager of*.

**Combe**, ANDREW, born at Edinburgh 1797, died 1847. He was educated at the Edinburgh High School, and afterwards for the medical profession at the university there. In 1822 he commenced practice at Edinburgh, and had considerable success. In 1838 he was appointed one of the physicians extraordinary to the queen in Scotland. His chief works are: *Observations on Mental Derangement* (1831), *Principles of Physiology* (1834), *Physiology of Digestion*

(1836), and *A Treatise on the Physiological and Moral Management of Infancy* (1840). Like his brother George he was a zealous phrenologist.

**Combe, GEORGE**, brother of the foregoing, was born 1788, at Edinburgh; died at Moore Park, Surrey, 1858. He was bred to the law, and in 1812 was admitted a member of the Society of Writers to the Signet. He was the first to introduce the doctrines of phrenology into Great Britain; and visited Germany and America lecturing on his favourite science. He was also a zealous promoter of the cause of popular education and social progress; and was among the first to advocate compulsory education and the establishment of a board of health. Besides the *Constitution of Man*, published in 1828, and which has had an enormous circulation, he is the author of *A System of Phrenology* (1825); *Lectures on Popular Education* (1833); *Moral Philosophy* (1840); *The Life and Correspondence of his brother, Dr. Andrew Combe* (1850); *Principles of Criminal Legislation and Prison Discipline Investigated* (1854); and *the Relation between Science and Religion* (1857).

**Combe, WILLIAM.** See *Coombe, William*.

**Combermere, SIR STAPLETON STAPLETON-COTTON, VISCOUNT**, English general, born in 1773, died 1865. He entered the army in 1790, and took part in the Mysore war against Tippoo Saib in 1798 and 1799. He served with distinction through the Peninsular war, and was commander of the allied cavalry after 1810. In 1814 he was created Baron Combermere. In 1825 he was appointed commander-in-chief in India. He was latterly Constable of the Tower, and a field-marshal.

**Combination.** See *Permutations and Combinations*.

**Combretaceæ**, an order of shrubby or arborescent polypetalous exogens, tropical shrubs or trees, with leaves destitute of stipules, and long slender stamens. Some of them are astringent and used for tanning (myrobolans), and the kernels of others are eatable. They are chiefly valued for their brightly-coloured showy flowers, especially in the genus *Combrētum*.

**Combustion**, the operation of fire on inflammable substances; or the union of an inflammable substance with oxygen or some other supporter of combustion, attended with heat and in most instances with light. In consequence of the combination of the carbon in fuel with the oxygen

of the air being the universal method of getting heat and light, and as when the action takes place the fuel is said to burn or undergo combustion, the latter term has been extended to those cases in which other bodies than carbon—for example, phosphorus, sulphur, metals, &c.—burn in the air or in other substances than air—for example, chlorine. Though the action between the gas and the more solid material, as coal, wood, charcoal, of whose combination combustion is the result, is mutual, the one having as much to do with the process as the other, yet the former, as oxygen, chlorine, iodine, and the compounds which they form with each other and with nitrogen, have received the name of supporters of combustion, while to the latter the term combustibles has been assigned.

*Spontaneous Combustion* is the ignition of a body by the internal development of heat without the application of fire. It not unfrequently takes place among heaps of rags, wool, and cotton when lubricated with oil; hay and straw when damp or moistened with water; and coal in the bunkers of vessels. In the first case the oil rapidly combines with the oxygen of the air, this being accompanied with great heat; in the second case the heat is produced by a kind of fermentation; in the third by the pyrites of the coal rapidly absorbing and combining with the oxygen of the air. The term is also applied to the extraordinary alleged phenomenon of the human body being reduced to ashes without the direct application of fire. It is said to have occurred in the aged and persons that were fat and hard drinkers; but most chemists reject the theory altogether, maintaining that none of the instances adduced are well authenticated.

**Comédie Française**, the national subsidized theatre of France, formed in 1680 by the fusion of the two bodies into which Molière's company of actors had split. It is at present managed by regulations made in 1812, modified by subsequent resolutions.

**Comédie Humaine.** The name of De Balzac's complete works. See *Balzac*.

**Comediet'ta**, a dramatic composition of the comedy class; not so much elaborated.

**Com'edy**, a dramatic composition of a light and amusing class, its characters being represented as in the circumstances or meeting with the incidents of ordinary life; distinguished from *tragedy* by its sprightliness, and the termination of its plot or intrigue being happy; and from *farce* by its greater

refinement and moderation, and by more of probability and less of burlesque. See *Drama*.

**Come'nus**, JOHANN AMOS, a Moravian educational reformer, born 1592, died 1671. He was chosen bishop of the Moravian Brethren, and suffered much in the persecutions of that body. He was the author of upwards of ninety works, the most important of which are *Janua Linguarum Reserata* (1631) and *Orbis Sensualium Pictus* (1658). His high reputation brought him invitations from England, Sweden, and Hungary to aid in organizing public instruction; and the above works have been frequently translated and imitated.

**Com'ets**, certain celestial bodies which appear at irregular intervals, moving through the heavens in paths which seem to correspond with parabolic curves, or in a few instances in elliptical orbits of great eccentricity. The former, after being visible from the earth for a shorter or longer time, disappear into space apparently never to return; the latter return to us periodically. Some comets are only visible by the aid of the telescope, while others can be seen by the naked eye. In the latter case they usually appear like stars accompanied with a train of light, sometimes short and sometimes extending over half the sky, mostly single and more or less curved, but sometimes forked. In a comet which appeared in 1744 the train was divided into several branches, spreading out from the head like a fan. The train is not stationary relatively to the head, but is subject to remarkable movements. The direction in which it points is always opposite to the sun, and as the comet passes its perihelion the train changes its apparent position with extraordinary velocity. The head of the comet is itself of different degrees of luminosity, there being usually a central core, called the *nucleus*, of greater brilliancy than the surrounding envelope, called the *coma*.

Comets were long regarded as supernatural objects, and usually as portents of impending calamity. Tycho Brahe was the first who expressed a rational opinion on the subject, coming to the conclusion that the comet of 1577 was a heavenly body at a greater distance from the earth than that of the moon. The general law of the motion of bodies, as well as his own observations on the comet of 1680, led Newton to conclude that the orbits of the comets must, like those of the planets, be ellipses, having the sun in one focus, but far more eccentric; and having

their *aphelions*, or greater distances from the sun, far remote in the regions of space. This idea was taken up by Halley, who collated the observations which had been made of all the twenty-four comets of which notice had been taken previous to 1680. The results were very interesting. With but few exceptions the comets had passed within less than the earth's shortest distance from the sun, some of them within less than one-third of it, and the average about one-half. Out of the number, too, nearly two-thirds had had their motions retrograde, or moved in the opposite direction to the planets. While Halley was engaged on these comparisons and deductions the comet of 1682 made its appearance, and he found that there was a wonderful resemblance between it and three other comets that he found recorded—the comets of 1456, of 1531, and of 1607. The times of the appearance of these comets had been at very nearly regular intervals, the average period being between seventy-five and seventy-six years. Their distances from the sun, when in *perihelion*, or when nearest to that luminary, had been nearly the same, being nearly six-tenths of that of the earth, and not varying more than one-sixtieth from each other. The inclination of their orbits to that of the earth had also been nearly the same, between  $17^{\circ}$  and  $18^{\circ}$ ; and their motions had all been retrograde. Putting these facts together, Halley concluded that the comets of 1456, 1531, 1607, and 1682 were reappearances of one and the same comet, which revolved in an elliptic orbit round the sun, performing its circuit in a period varying from a little more than seventy-six years to a little less than seventy-five; or having, as far as the observations had been carried, a variation of about fifteen months in the absolute duration of its year, measured according to that of the earth. For this variation in the time of its revolution Halley accounted upon the supposition that the form of its orbit had been altered by the attraction of the remote planets Jupiter and Saturn as it passed near to them; and thence he concluded that the period of its next appearance would be lengthened, but that it would certainly reappear in 1758 or early in 1759. As the time of its expected reappearance approached, Clairaut calculated that it would be retarded 100 days by the attraction of Saturn, and 518 by that of Jupiter, so that it would not come to the perihelion, or point of its orbit nearest the

## COMETS.

sun, till the 13th of April, 1759. It actually reached its perihelion on the 13th of March, 1759, being thirty days earlier than he had calculated. Along with the period of this comet and its perihelion distance, the magnitude and form of its path were also calculated. Estimating the mean distance of the earth from the sun at 95,000,000 miles (the number which was at that time considered as the true one), the mean distance of the comet was calculated to be 1,705,250,000 miles; its greatest distance from the sun, 3,355,400,000; its least distance, 55,100,000; and the transverse or largest diameter of its orbit, 3,410,500,000. This comet, therefore, is a body belonging to the solar system, and quite beyond the attraction of any body which does not belong to that system; and as this is determined of one comet, analogy points it out as being the case with them all. In 1835 it again returned, being first seen at Rome, August 5, and from that time continued to be observed till the end of the year in Europe, and through a great part of spring 1836 in the southern hemisphere.

The comet denominated *Encke's comet*, which has made repeated appearances, was first observed in 1818, and was identified with a comet observed in 1786, also with a comet discovered in 1795 by Miss Herschel in the constellation Cygnus, and with another seen in 1805. Its orbit is an ellipse of comparatively small dimensions, wholly within the orbit of Jupiter; its period is 1260 days, or about three years and three-tenths. It has been frequently observed since. Another comet, the history of which is of the utmost importance in the latest theories regarding the connection of these bodies and the periodic showers of shooting-stars, is one known as Biela's comet, discovered in 1826. It revolved about the sun in about  $6\frac{3}{4}$  years, and was identified as the same comet which was observed in 1772 and in 1806. Its returns were noted in 1832, 1839, and 1845. In 1846 it divided into two, returned double in 1852, but has not since been seen, the supposition being that it has been dissipated, and that it was represented by a great shower of meteors that were seen in Nov. 1872. One of the most remarkable comets of recent times was that known as Donati's, discovered by Dr. Donati of Florence in 1858. It was very brilliant in England in the autumn of that year, and on the 18th of October was near coming into collision with Venus. The year 1881 was remark-

able for the number of comets recorded. During that year no fewer than seven comets, including the well-known short-period comet Encke's, were observed.

The paths in which comets move are not, like those of the planets, all nearly in the same plane as the orbit of the earth, but are inclined to that orbit at all angles. Leaving out the small planets that have recently been discovered, all the others are contained within a zone extending only  $7^\circ$  on each side of the earth's orbit; and, with the exception of Mercury (by far the smallest of the *old* planets), they are within half that space. But the orbits of the comets are at all possible angles; and the number increases with the angle, so that they approximate to an equal distribution in all directions round the sun as a centre. Taking all the orbits of which the inclinations have been ascertained, it has been found that of every hundred the inclinations are as follows: from  $0^\circ$  to  $30^\circ$ , 26;  $30^\circ$  to  $50^\circ$ , 27;  $50^\circ$  to  $89^\circ$ , 39; and  $80^\circ$  to  $90^\circ$ , 8. The comets that have been observed have made their passages through very different parts of the solar system: 24 have passed within the orbit of Mercury, 47 within that of Venus, 58 within that of the Earth, 73 within that of Mars, and the whole within that of Jupiter. Of a hundred or thereabouts, mentioned by Lalande, about one-half have moved from west to east, in the same direction as the planets, and the other half in the opposite direction. The direct and retrograde ones do not appear to follow each other according to any law that has been discovered. From 1299 to 1532 all that are mentioned were retrograde; and five that were observed from 1771 to 1780 were all direct.

That the comets are formed of matter of some sort or other we know from the dense and opaque appearance of their nucleus, as well as from the action of the planets upon them; but as their action upon the planets has not been great, or even perceptible, we are led to the conclusion that they are not bodies of the same density or magnitude as even the smallest and rarest of the planets. One modern theory of the nature of comets is that these bodies were ejected millions of years ago from the interior of suns, or planets in a sunlike state. When a comet is viewed through a telescope of considerable power there appears a dense nucleus in the centre of the luminous and apparently vaporous matter of which the external parts

are composed; and the opacity of this nucleus varies in different comets. On its first appearance, and again when it recedes, the luminous part of the comet is faint and does not extend far from the nucleus; but as it moves on towards the perihelion the brightness increases, and the luminous matter lengthens into a train, which, in some cases, has extended across a fourth of the entire circumference of the heavens. The most remarkable discovery of recent times regarding comets is the identity of the course of some of them with the orbit of certain showers of shooting-stars. This was first demonstrated by the Italian astronomer Schiaparelli, who proved the agreement between the orbit of the great comet of 1862 and that of the star-shower seen annually about August 9, 10. It has since been demonstrated that every meteoric stream follows in the train of some comet large or small, which either exists now or has been dissipated, as Biela's comet was, leaving only its meteoric trail to show where it once travelled; and that every comet is followed or preceded by a train of meteors, extending over a greater or less portion of the comet's orbit according to the length of time during which the comet has existed.

**Com'frey**, a name given to several European and Asiatic plants of the genus *Symphytum*, nat. order Boraginaceæ. The common comfrey, *S. officināle*, is found on the banks of rivers and ditches. Its root abounds in mucilage, which is useful in irritations of the throat, intestines, and bladder.

**Comines**, PHILIPPE DE. See *Commines*.

**Comiso** (kō-mē'sō), a town of Sicily, prov. Syracuse. Pop. 19,333.

**Comitia**, with the Romans, the assemblies of the people in which such public business was transacted as the election of magistrates, the passing of laws, &c. These were of three kinds: (1) The *comitia curiata*, or assemblies of the patrician houses or *populus* in wards or *curiæ*. (2) The *comitia centuriata*, or assemblies of the whole Roman people, including patricians, clients, and plebeians in divisions called *centuries*. These assemblies are said to have been instituted by King Servius Tullius as a counterpoise to the powers of the *comitia curiata*. After the institution of the *centuriata* the functions of the *curiata* were almost confined to the election of priests, and the confirmation of dignities imposed by the people. The *centuriata* had the election of consuls, the

deciding on war, the acceptance or rejection of laws, &c. (3) The *comitia tributa*, or assemblies of the plebeian tribes only. The *tributa* were instituted not long after the expulsion of the kings, and originally transacted matters pertaining to the plebeians alone, but latterly had wider functions, electing the inferior magistrates, &c.

**Comity of Nations** (*comitas gentium*), a phrase adopted in international law to denote that kind of courtesy by which the laws and institutions of one state or country are recognized and given effect to by the government of another.

**Comma**, in punctuation, the point [, ] denoting the shortest pause in reading, and separating a sentence into divisions or members according to the construction.—In music, a comma is the smallest enharmonic interval, being the difference between a major and a minor tone, and expressed by the ratio 80:81.

**Comman'der**, a chief; the chief officer of an army or any division of it. The office of *Commander-in-chief* is the highest staff appointment in the British army. The title is sometimes not commander-in-chief, but field-marshal commanding-in-chief, the difference being that the former is appointed by patent for life, while the latter is appointed by a letter of service, and holds office only during the pleasure of the sovereign. In the United States the President is declared by the Constitution to be commander-in-chief of the army and navy. In the navy, a commander holds a definite rank above lieutenant and under captain. In matters of etiquette he ranks with a lieutenant-colonel in the army.

**Comman'dery**, a term used in several senses in connection with some of the military and religious orders. Among several orders of knights, as the Templars, Hospitalers, &c., it was a district under the control of a member of the order (called commander or preceptor), who received the income of estates belonging to knights within that district, and expended part for his own use and accounted for the rest; now more especially applied to a manor belonging to the priory of the Knights Hospitalers or Knights of St. John of Jerusalem. In certain religious orders, as those of St. Bernard and St. Anthony, it was the district under the authority of a dignitary called a commander.

**Commandite** (kom-mān-dēt), a term used in France, a partnership *en commandite* be-



ing one in which a person may advance capital without taking an active part in the management of the business, and be exempt from responsibility for more than he put into it; much the same as limited liability.

**Commandments.** See *Decalogue*.

**Commemoration**, at the University of Oxford, the day on which the annual solemnity in honour of the benefactors of the university is held, when orations are delivered, and prize compositions are read in the theatre, and honorary degrees conferred upon distinguished persons.

**Commencement**, in Cambridge University, and also in the universities of the United States, the day when masters of arts and doctors receive their degrees.

**Commen'dam**, the administrative or provisional management of a benefice during a vacancy. The person intrusted with the management was called *commendator*. The grant of ecclesiastical livings in this way gave rise to great abuses. In England the term was applied to a living retained by a bishop after he had ceased to be an incumbent. By 6 and 7 William IV. the holding of livings *in commendam* was, for the future, abolished.

**Commen'sal** (*L. con*, and *mensa*, a table), a messmate; applied in zoology to animals which live on or in other animals for part or the whole of their life, simply sharing the food of their host without being parasitic on him: thus the pea-crabs live within the cavity of shell-fish, and find their food in the water introduced for the benefit of their host.

**Commen'surable**, an appellation given to such quantities or magnitudes as can be measured by one and the same common measure. *Commensurable numbers* are such as can be measured or divided by some other number without any remainder; such are 12 and 18, as being measured by 6 or 3.

**Comm'entary**, a term used (1) in the same sense as *memoirs*, for a narrative of particular transactions or events, as the *Commentaries* of Cæsar. (2) A series or collection of comments or annotations. These may either be in the form of detached notes, or may be embodied in a series of remarks written and printed in a connected form.

**Commentry** (*kom-män-trē*), a town of France, dep. of Allier, 8 m. S.E. of Montluçon, in the midst of a vast coal-field, to which the town owes its prosperity. Pop. 12,416.

**Comm'erce**, the interchange of goods, merchandise, or property of any kind between countries or communities; trade; traffic.

**Commerce**, CHAMBER OF, a board chosen from among the merchants and traders of a city to protect the interests of commerce; to lay before the legislature the views of their members on matters affecting commerce; to furnish statistics as to the staple trade of the locality; and to attain by combination advantages which could not be reached by private enterprise, &c. These associations originated in France early in the 18th century. The first in Britain was that of Glasgow (1783); now all the great towns have their chamber. A system of international chambers of commerce for promoting relations with foreign countries has been largely adopted. Nearly all large cities in the United States have chambers of commerce. Some are incorporated.

**Commercial Law** (or the *law merchant*), the law which regulates commercial affairs among the merchants of different countries, or among merchants generally. It is derived from the different maritime codes of mediæval Europe, the imperial code of Rome, international law, and the custom of merchants. Lord Mansfield (1704-93) was the first great exponent of commercial law in Britain. In this country the term is applied to that system of laws which refers to mercantile contracts, and is based upon the custom of merchants. The principal subjects embraced within it are the laws of shipping, including that of marine insurance; the law of negotiable bills of exchange and promissory notes; and the law of sales.

**Commercial Treaties**, treaties entered into between two countries for the purpose of improving and extending their commercial relations; each country engaging to abolish or to reduce to an agreed rate or otherwise modify the duties on articles of production and manufacture imported from the one country into the other. They are usually for a limited period, but may be renewed and modified according to altering conditions. In these treaties the phrase, 'most favoured nation,' implies concessions equal to the most favourable granted under any similar treaty. The first treaty of commerce made by England with any foreign nation was entered into with the Flemings in 1272; the second was with Portugal and Spain, 1308. A treaty establishing reci-

procuity of trade between the United States and Canada has been under discussion for some years. A treaty of like nature has been negotiated with Brazil and Spain, Germany, Austria-Hungary, British West Indies, Cuba, Porto Rico, San Domingo, Salvador, Guatemala, Honduras, Guiana, and the South American republics.

**Commercy**, a town, France, dep. Meuse, on the Meuse, 21 miles E. of Bar-le-Duc. Pop. 5262.

**Commination**, an office in the liturgy of the Church of England, appointed to be read on Ash Wednesday or on the first day of Lent, containing a recital of God's anger and threatenings towards sinners.

**Communes**, or **COMINES** (ko-mēn), two towns, one in France, the other in Belgium, on opposite sides of the Lys, 8 miles N. of Lille. Anciently they formed a single town, which was fortified and had a castle, in which Philip de Communes was born. Pop. of French Communes, 6637; of Belgian Communes, 3480.

**Communes** (ko-mēn), **PHILIPPE DE**, French writer and statesman, born 1445 at Communes, died 1509. He became confidential adviser of Charles the Bold, duke of Burgundy, but in 1472 he passed into the service of Louis XI., who loaded him with marks of favour. After the death of Charles the Bold Louis took possession of the duchy of Burgundy, sent Communes there, and soon after appointed him ambassador to Florence. He was afterwards sent by Louis to Savoy, for the purpose of seizing the young Duke Philibert, and of placing him entirely under the guardianship of the king, his uncle. In 1483 Louis XI. died, and next year Communes attended Charles VIII. in his invasion of Italy, and served him in a diplomatic capacity. Soon after that date he began to write his Memoirs, valuable as contributions to the history of his times. The first edition was published at Paris between 1523 and 1528. He relates in them the events which occurred during his life, and in most of which he had an active share, in lively natural language, and displays everywhere a correct judgment, acute observation, and a profound knowledge of men and things.

**Commissariat**, the department of an army whose duties consist in supplying transport, provisions, forage, camp equipage, &c., to the troops; also, the body of officers in that department. In the British army the commissariat and transport are under the Ordnance Store Dept. with two commis-

saries-general and a number of deputy-commissaries-general, assistant commissaries-general, &c. In the United States army the Subsistence Department has one brigadier-general (commissary-general of subsistence), two colonels, three lieutenant-colonels, eight majors, and twelve captains.

**Com'missary**.—1. As an ecclesiastical term, an officer of a bishop who exercises spiritual jurisdiction in remote parts of a diocese, or one intrusted with the performance of the duties in the bishop's absence. 2. In the army a term applied to officers charged with furnishing provisions, &c., for its use.

**Com'missary-court**, in Scotland, a sheriff or county court which decrees and confirms executors to deceased persons leaving personal property in Scotland, and discharges relative incidental functions.

**Commis'sion**, a formal act of trust; a warrant by which any trust is held or authority exercised.—A written document, investing a person with an office or certain authority.—A certificate issued by authority by which a military officer is constituted; as, a captain's *commission*.—A body of persons joined in an office of trust, or their appointment; as, a building *commission*.—Brokerage, allowance, or compensation made to a factor, agent, &c., for transacting the business of another; as one per cent. *commission* on sales.—*Commission of bankruptcy*, a commission appointed to investigate the facts relative to an alleged bankruptcy, and to secure all available assets and effects for the creditors concerned.—

A *commission merchant* is one who sells goods on behalf of another, being paid by a certain percentage which is called his *commission*.—*Putting a ship in commission*, is fitting her out for service after she has been laid up.

**Commissionaire**, one of a body of public messengers in Britain originally selected from the wounded soldiers of the Crimean and Indian wars. They receive their appointment from a society established by Capt. Walter in 1859, which is now under the patronage of the queen and the commander-in-chief. They are established in most of the great cities, and their charges are regulated by a tariff.

**Commissioners of Highways**, officers having certain powers and duties concerning the highways within the limits of their jurisdiction. In some of the States they are county officers, and their jurisdiction

is co-extensive with the county. In others they are town or township officers. They have power to establish, repair or vacate highways, and it is their duty to cause them to be kept in good order.

**Com'missure**, in anatomy, a joining or union of two parts, as the sutures of the skull; or a part joining others, as the *corpus callosum* or *great commissure* of the brain.

**Commit'tee**, one or more persons elected or appointed to attend to any matter or business referred to them either by a legislative body, or by a court, or by any corporation, or by any society or collective body of men acting together. In parliament, when a committee consists of the whole members of the body acting in a different capacity from that which usually belongs to them it is called a *committee of the whole house*, the business of which is conducted under somewhat different regulations from those under which the business of the house when not in committee is carried on. Familiar examples are *committees of supply* and *committees of ways and means*.—*Standing committees* are such as continue during the existence of parliament, and to these are committed all matters that fall within the purposes of their appointment, as the committee of elections or of privileges, &c.—*Select committees* are appointed to consider and report on particular subjects.—When the House of Representatives resolves itself into the Committee of the whole House the Speaker leaves the chair, which is occupied by one of the members, denominated the Chairman of Committee.

**Committee of Public Safety** (*Comité du Salut Public*), a body elected by the French Convention (6th April, 1793) from among its own members, at first having very limited powers conferred upon it—that of supervising the executive and of accelerating its actions. Subsequently, however, its powers became extended; all the executive authority passed into its hands, and the ministers became merely its scribes. It was at first composed of nine, but was increased to twelve members, viz.: Robespierre, Danton, Couthon, St.-Just, Prieur, Robert-Lindet, Héroult de Séchelles, Jean-Bon St.-André, Barrère, Carnot, Collot d'Herbois, and Billaud Varennes. The severe government of this body is known as the Reign of Terror, which ended with the execution of Robespierre and his associates in July, 1794. During the commune (March

to May, 1871) a similar committee was established in Paris.

**Com'modore**, in the British navy, an officer, generally a captain, holding a temporary commission with a rank between that of captain and admiral, who commands a ship or detachment of ships in the absence of an admiral. They are of two kinds—one having a captain under him in the same ship, and the other without a captain. The former has the rank, pay, and allowance of a rear-admiral, the latter the pay and allowance of a captain, with a special allowance as the admiralty may direct. They both carry distinguishing pennants. There is a similar rank in the U. S. navy. The title is also given to the senior captain of a line of merchant vessels, and also to the president of a yachting club.

**Com'modus**, L. ÆLIUS AURELIUS, a Roman emperor, son of Marcus Aurelius, was born A.D. 161, killed 192. He succeeded his father 180, and gave early proofs of his cruel and voluptuous character. He gave himself up to the lowest society and the most shameless habits. He used to fight in the circus like a gladiator, and caused himself to be worshipped as Hercules. One of his concubines, whom he intended to put to death, administered poison to him; but it operated too slowly, and he was strangled by a favourite athlete.

**Com'mon**, in law, 'a profit which a man hath in the land of another.' There are certain rights of common which are recognized by the common law, namely, of *pasture*, of *piscary* or fishing, of *estovers* or cutting wood, and of *turbary* or of digging turf. But the phrase usually means the right of pasturing cattle, horses, &c., in a certain field, or within a certain territory. These rights, in England, have been mostly determined by prescription or innemorial usage. In Scotland a common is a piece of ground of which there is no superior, but the land is the land of the community generally.

**Common Carriers.** See *Carriers*.

**Common Council**, the council of a city or corporate town, empowered to make by-laws for the government of the citizens. The common councils sometimes consist of two houses, chambers, or courts, and sometimes form only one. In our American cities the city council is generally composed of two branches, called, respectively, select and common. They are elected by the people.

**Com'moner**, in Britain, a term applied to all citizens except the hereditary nobility.

**Common Law**, the unwritten law, the law that receives its binding force from immemorial usage and universal reception, in distinction from the written or statute law; sometimes from the civil or canon law; and occasionally from the *lex mercatoria*, or commercial and maritime jurisprudence. It consists of that body of rules, principles, and customs which have been received from former times, and by which courts have been guided in their judicial decisions. The evidence of this law is to be found in the reports of those decisions and the records of the courts. Some of these rules may have originated in edicts or statutes which are now lost, or in the terms and conditions of particular grants or charters; but it is quite certain that many of them originated in judicial decisions founded on natural justice and equity, or on local customs. It is contrasted with (1) the statute law contained in acts of parliament; (2) equity, which is also an accretion of judicial decisions, but formed by a new tribunal, which first appeared when the common law had reached its full growth; and (3) the civil law inherited by modern Europe from the Roman Empire. Wherever statute law, however, runs counter to common law, the latter is entirely overruled; but common law, on the other hand, asserts its pre-eminence where equity is opposed to it.

**Common Pleas**, in law, pleas brought by private persons against private persons, or by the government, when the cause of action is of a civil nature. In many States of the United States a court having jurisdiction generally in civil actions. In England the Court of Common Pleas is now merged in the High Court of Justice.

**Common Prayer, Book of**, the liturgy or public form of prayer prescribed by the Church of England to be used in all churches and chapels, and which the clergy are to use under a certain penalty. The Book of Common Prayer is used also by the English-speaking Episcopal churches in Scotland, Ireland, America, and the colonies, as well as by some non-episcopal bodies, with or without certain alterations. It dates from the reign of Edward VI.; was published in 1549, and again with some changes in 1552. Some slight alterations were made upon it when it was adopted in the reign of Elizabeth. In the reign of James I., and finally

soon after the Restoration, it underwent new revisions. The Book of Common Prayer of the Protestant Episcopal Church in America was ratified, after several revisions of the English book, in 1789, and was in general use until the adoption of the "Standard" at the General Convention, Baltimore, Md., October, 1892. It was published Easter, 1893, and is now in general use.

**Commons, HOUSE OF.** See *Britain and Parliament*.

**Common Schools**, a term used in the U. States as equivalent to primary or elementary schools. Supported by taxation and the rent or sale of school-lands.

**Common Sense**, the philosophy of the so-called Scotch school of philosophy founded by Thos. Reid (1710-96), who aimed to establish a series of fundamental truths indisputable as primitive facts of consciousness.

**Common Serjeant**, a judicial officer of the London corporation, who assists the recorder in criminal affairs.

**Common Time**, in music, is that in which every bar contains an even number of subdivisions, such as two minims, four quavers, or their equivalents. It is of two kinds simple and compound. Simple common time is that which includes four beats in a bar, or any division of that number, or square of the number or its divisions. Compound common time includes two or four beats of three crochets or quavers to each beat.

**Com'monwealth**, the whole body of people in a state; the body politic. In Eng. hist. the name given to the form of government established after the death of Charles I., and which lasted until the restoration of Charles II. (1649-59).

**Com'munalism**, the theory of government by communes or corporations of towns and districts, adopted by the advanced republicans of France and elsewhere. The doctrine is that every commune, or at least every important city commune, as Paris, Marseilles, Lyons, &c., should be a kind of independent state in itself, and France merely a federation of such states. This system must not be confounded with *Communism*, with which, however, it is naturally and historically allied, though the two are perfectly distinct in principle.

**Com'mune**, a small territorial district in France, being one of the subordinate divisions into which that country is parcelled out; the name is also given to similar divi-

sions in some other countries, as Belgium. In the country a commune sometimes embraces a number of villages, while some large cities are divided into a number of communes. In either case each commune is governed by an officer called a mayor.

**Commune of Paris.**—1. A revolutionary committee which took the place of the municipality of Paris in the French revolution of 1789, and soon usurped the supreme authority in the state. Among its chiefs were some of the most violent of the demagogues, such as Hébert, Danton, and Robespierre. 2. The name adopted by the ultra-radical party in Paris brought once more into prominence by the events of the Franco-German war, more immediately by the siege of Paris (Oct. 1870 to Jan. 1871). They ruled over Paris for a brief period after the evacuation of the German troops, and had to be suppressed by troops collected by the National Assembly of France. The rising was entirely political and confined to Paris; it was based on no well-defined dogmas, only a fractional part of the communal government being communists in the economic sense, and these were soon thrust aside by their more violent and unscrupulous comrades. Much bloodshed and wanton destruction of property took place before the rising was put down by M. Thiers' government.

**Communion**, the act of partaking with others of the sacramental symbols in the Lord's Supper. See *Lord's Supper*.

**Communism**, the economic system or theory which upholds the absorption of all proprietary rights in a common interest, an equitable division of labour, and the formation of a common fund for the supply of all the wants of the community; the doctrine of a community of property, or the negation of individual rights in property. No communistic society has as yet been successful. Robert Owen made several experiments in modified communism, but they failed. St. Simon, Fourier, and Proudhon have been the chief exponents of the system in France; and under the names of socialism, nihilism, &c., it seems to be working as a great unseen force in several countries.

**Commutator**, a piece of apparatus used in connection with many electrical instruments for reversing the current from the battery, without the necessity of changing the arrangement of the conductors from the poles.

**Comneni**, an extinct family of sovereigns,

statesmen, generals, and authors, said to be of Italian origin, to which belonged, from 1057 to 1185, six emperors of the East—Isaac I., Alexis I., John II., Manuel I., Alexis II., and Andronicus I. When the Crusaders had overturned the throne of the Comneni in Constantinople a prince of that house founded an independent state at Trebizond in Asia Minor, where he was governor (1204). The last sovereign of this house was David Comnenus (1461). A remarkable member of the family was the Princess Anna Comnena. See *Anna Comnena*.

**Como** (anc. *Comum*), capital of the province of Como, in the north of Italy (Lombardy), 24 miles N.N.W. of Milan, in a delightful valley at the S.W. extremity of Lake Como. It has a splendid marble cathedral dating from the 14th century, the old church of S. Fedele of the 10th century, the town-hall finished in 1215, the fine theatre built in 1813. Here were born Pliny the elder and younger, and Volta the natural philosopher. Pop. 25,560.—The province of Como has an area of 1049 square miles, and a pop. 1891. of 555,682.

**Como**, LAKE OF (*Lago di Como*, anciently *Lacus Larius*), a lake in the north of Italy, at the foot of the Alps, fed and drained by the river Adda, which carries its surplus waters to the Po. It extends from south-west to north-east 30 miles, giving off towards the middle, at the promontory where stands Bellaggio, a branch running for about 13 miles south-east to Lecco, called the Lake of Lecco; greatest width  $2\frac{1}{2}$  miles, greatest depth 1929 feet. It is celebrated for the beautiful scenery of its shores, which are covered with handsome villas, gardens, and vineyards, mountains rising behind to the height of 7000 feet. Trout and other fish abound in the lake.

**Comorin**, a cape forming the south extremity of Hindustan (lat.  $8^{\circ} 4' N.$ , lon.  $77^{\circ} 35' E.$ ) and consisting of a low sandy point.

**Comoro Islands**, a volcanic group in the Indian Ocean, between the northern extremity of Madagascar and the continent of Africa. They are four in number: Great Comoro, Mohilla, Johanna, and Mayotta; total area, 1050 sq. miles; pop. 65,000. The people are nominally Mohammedans, and are akin to the mixed races of Zanzibar. They have large flocks and herds; and the coast lands are very fertile, abounding in tropical grains and fruits. Mayotta belonged to France since 1843, and in 1886 the others became a French possession.

**Companies, JOINT-STOCK.** See *Joint-stock Companies* and *Partnership*.

**Compan'ion**, a raised hatch or cover to the cabin stair of a merchant vessel.—*Companion Ladder*, the steps or ladder by which persons ascend to and descend from the quarter-deck.

**Com'pany**, in military language, a subdivision of an infantry regiment or battalion, corresponding to a troop of cavalry or a battery of artillery, consisting of from 60 to 100 men and commanded by a captain.

**Comparative Anatomy.** See *Anatomy*.

**Comparison, DEGREES OF**, in grammar, inflections of adjectives or adverbs to express degrees of the original quality, usually divided into positive, comparative, and superlative; as *strong, stronger, strongest, glorious, more glorious, most glorious*.

**Compass**, an instrument used to indicate the magnetic meridian or the position of objects with respect to that meridian, and employed especially on ships, and by sur-

middle of the 13th century. As now generally used it consists of three parts: namely, the box, the card or fly, and the needle—the



Compass Card.

latter being the really essential part, and consisting of a small magnet so suspended that it may be able to move freely in a horizontal direction. The box, which contains the card and needle, is, in the case of the common *mariner's compass*, a circular brass receptacle hung within a wooden one by two concentric rings called gimbals, so fixed by the cross centres to the box that the inner one, or compass-box, shall retain a horizontal position in all motions of the ship. The circular card is divided into thirty-two equal parts by lines drawn from the centre to the circumference, called points or rhumbs; the intervals between the points are also divided into halves and quarters, and the whole circumference into equal parts or degrees, 360 of which complete the circle; and, consequently, the distance or angle comprehended between any two rhumbs is equal to  $11\frac{1}{4}^{\circ}$ . The four principal are called cardinal points: viz. North, South, East, and West. The names of the rest are compounded of these. The needle is a small bar of magnetized steel. It is fixed on the under side of the card, and in the centre is placed a conical socket, which is poised on an upright pointed pin fixed in the bottom of the box; so that the card, hanging on the pin, turns freely round its centre, and one of the points, by the property of the needle, will always be directed towards the north pole. The needle, however, is liable to a certain deviation owing to the magnetism of the ship itself, and this is especially strong in iron ships. (See *Deviation*.) To obviate this defect Sir W. Thomson has invented a compass, having a number of

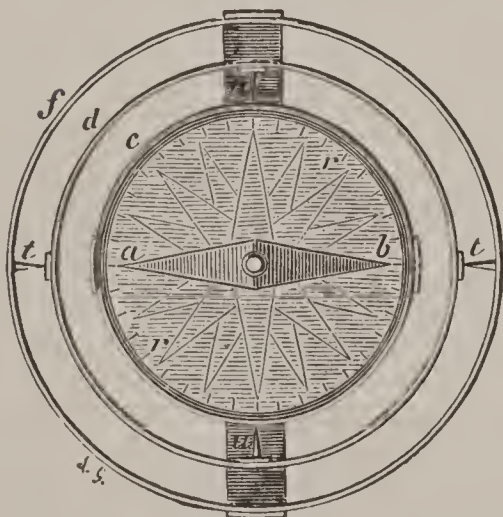
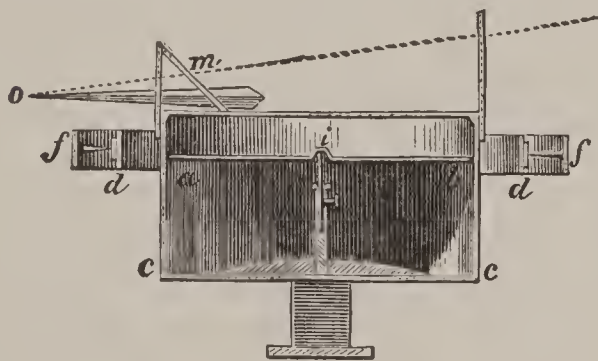

Ship's Compass.

*ab*, Needle. *cc*, Box. *dd*, Inner gimbal. *ff*, Outer gimbal. *i*, Pivot upon which the card is placed. *m*, Reflector. *rr*, Card. *tt*, *uu*, Supporting pivots.

veyors and travellers. Its origin is unknown, but it is supposed to have been brought from China to Europe about the

needles arranged in a particular manner instead of one. In this compass quadrantal errors are corrected by means of two iron globes fixed on opposite sides of the binnacle; while the various components of the ship's magnetic force are neutralized by a series of bar-magnets so arranged as to act as correctors. In the compass used by land-surveyors and others the needle is not fixed to the card, but plays alone, the card being drawn on the bottom of the box.

**Compasses**, or PAIR OF COMPASSES, a mathematical instrument used for the describing of circles, measuring lines, &c. They consist simply of two pointed legs, movable on a joint or pivot, and are used for measuring and transferring distances. For describing circles the lower end of one of the legs is removed and its place supplied by a holder for a pencil or pen.—*Hair Compasses* are compasses having a spring tending to keep the legs apart, and a finely-threaded screw by which the spring can be compressed or relaxed with the utmost nicety, and the distance of the legs regulated to a hair's-breadth.—*Bow Compasses* are compasses having the two legs united by a bow passing through one of them, the distance between the legs being adjusted by means of a screw and nut.—*Proportional Compasses* are compasses used for reducing or enlarging drawings, having the legs crossing so as to present a pair on each side of a common pivot. By means of a slit in the legs, and the movable pivot, the relative distances between the points at the respective ends may be adjusted at pleasure in the required proportion.

**Compass Plant** (*Silphium laciniatum*), a composite plant growing in the prairies of the Mississippi valley, and remarkable from the fact that its erect radical leaves stand so that their edges point almost exactly north and south, especially in midsummer. This is said to be due to the action of light, and to depend on the leaves having an equal number of stomata on either face.

**Compensation Balance**, PENDULUM, a balance-wheel or a pendulum so constructed as to counteract the tendency of variations of temperature to produce variations in the rate of vibration or oscillation. This may be accomplished in various ways, as by bars formed of two or more metals of different expansibilities, so that the expansion of one counteracts the expansion of another. They are used to produce perfect equality of motion in the balances of watches

and chronometers and the pendulums of clocks.

**Compiègne** (kōn-pyāny), a French town, dep. Oise, on the left bank of the Oise, 45 miles N.N.E. of Paris. It has a splendid château, built by St. Louis, rebuilt by Louis XIV., and improved by Louis XV., Louis XVI., and Napoleon I. It was the autumn resort of the court of Napoleon III. In 1430 Joan of Arc was taken prisoner here by the English. Pop. 11,453.

**Complexion**, the colour or hue of the skin, particularly of the face. The colour depends partly on pigment in the deep cells of the epidermis and partly on the blood supply. The nature and colour of the hair seems closely connected with the complexion, and these combined are important distinguishing marks of different races. See *Ethnology*.

**Com'pline**, the last of the daily canonical hours in the Roman Catholic breviary; the complement of the Vespers or evening office.

**Complutensian Polyglot**, a celebrated polyglot edition of the Bible published at Complutum, the ancient name of Alcalá de Henares, in Spain, 1514–17, by Cardinal Ximenes. See *Polyglot*.

**Compos'itæ**, the largest known nat. order of plants, containing over 12,000 described species of herbs or shrubs distributed all over the world. The flowers (generally called *florets*) are numerous (with few exceptions) and sessile, forming a close head on the dilated top of the receptacle, and surrounded by an involucre of whorled bracts. The flowers are monopetalous, and the order is divided into three natural groups from the form of the corolla: (1) *Tubulifloræ*, in which it is tubular, with five, rarely four, teeth; (2) *Labiatiflora*, in which it is divided into two lips; and (3) *Ligulifloræ*, in which it is slit or ligulate. The stamens are inserted on the corolla, and their anthers are united into a tube (syngenesious). The style is two-cleft at the apex. The fruit is dry and seed-like. The head of numerous florets was called by the older botanists a compound flower, hence the name. Many are common weeds, like the daisy, dandelion, thistle, &c.; many are cultivated in gardens, such as the asters, marigold, &c.; others have some economic or medicinal value, as chicory, artichoke, chamomile, lettuce, wormwood, arnica, &c.

**Composite Order**, in arch. the last of the five orders; so called because the capital belonging to it is composed out of those of the

other orders, borrowing a quarter-round from the Tuscan and Doric, a row of leaves from the Corinthian, and volutes from the Ionic. Its cornice has simple modillions or dentils. It is called also the *Roman* or the *Italic* order.

**Composition**, an arrangement which a bankrupt or person in pecuniary difficulties makes with his creditors, and by which he arranges to pay them a certain proportion only of the debts due. See *Bankruptcy*.

**Composition of Forces and Motions**, in mechanics, the union or assemblage of several forces or motions that are oblique to one another, into an equivalent force or motion in another direction. Thus two forces acting in the directions of the adjacent sides of a parallelogram, compose one force acting in the direction of the diagonal, and if the lengths of the adjacent sides represent also the magnitudes of the forces, the diagonal will represent the magnitude of the compound force or *resultant*.

**Compostella**. See *Santiago-de-Compostella*.

**Compostel'la**, ORDER OF ST. JAMES OF, an order of Spanish knights formed in the 12th century to protect the Christian pilgrims who flocked in vast numbers to Santiago-de-Compostella, where the relics of St. James were preserved. In time they attained great wealth, thereby exciting the jealousy of the crown, which succeeded in securing the grand-mastership in 1522, whereupon the order rapidly declined.

**Composts**, in agriculture, are mixtures of various fertilizing substances. See *Manure*.

**Compound Animals**, animals, many of which by no means belong to the lowest types, in which individuals, distinct as regards many of the functions of life, are yet connected by some part of their frame so as to form a united whole. Such are the *polyzoa* and some of the *ascidia*.

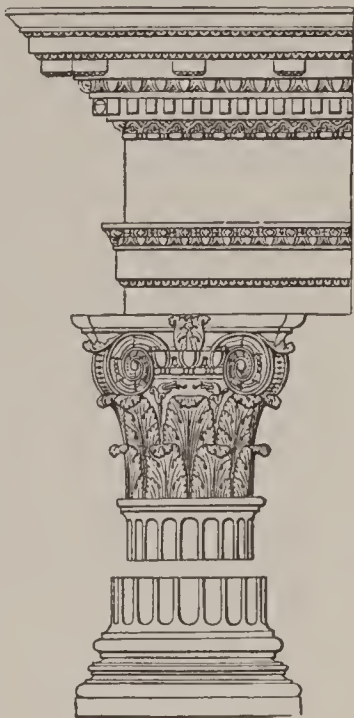

Composite Order.

**Compound Blow-pipe**, or OXYHYDROGEN BLOW-PIPE. See *Blow-pipe*.

**Compounding of Felony**, the accepting of a consideration for forbearing to prosecute; or the agreeing to receive one's goods again from a thief on condition of not prosecuting. This is an offence punishable by fine and imprisonment.

**Compound Radical**. See *Chemistry*.

**Compressed Air**, atmospheric air compressed by means of pumps, &c., and used in driving stationary and locomotive engines, and excavating machines; as also in working pneumatic despatch-tubes, railway-brakes, &c.

**Compressibility**, the property of bodies in virtue of which they may be pressed into smaller bulk. All bodies are probably compressible, though the liquids are but slightly so. The gases are exceedingly compressible, and may be liquefied by pressure and cold combined. Those bodies which occupy their former space when the pressure is removed, are called elastic.

**Compurga'tion**, a mode of defence allowed by the Anglo-Saxon law in England, and common to most of the Teutonic tribes. The accused was permitted to call a certain number (usually twelve) of men, called compurgators, who joined their oaths to his in testimony to his innocence. They were persons taken from the neighbourhood, or otherwise known to the accused, and acted rather in the character of jurymen than that of witnesses, for they swore to their belief, not to what they knew; that is, on the accused making oath of his innocence they swore that they believed he was speaking the truth. Compurgation in the ecclesiastical courts was not abolished till the reign of Elizabeth.

**Com'stock Lode**, a large and extremely rich metallic lode in the western part of Nevada, U. States, on the eastern slope of the Virginia Mountains. To it belong the Big Bonanza and other mines, which have yielded gold and silver to the value of over \$300,000,000.

**Comte** (kont), ISIDORE AUGUSTE MARIE FRANÇOIS XAVIER, founder of the 'positive' system of philosophy, was born at Montpellier on 12th January, 1798, died at Paris 1857. His family were zealous Catholics and royalists. He was educated at the École Polytechnique, and embraced enthusiastically the socialist tenets of St. Simon. As one of his most distinguished pupils he was employed, in 1820, to draw up a for-



mula of the doctrines professed by the St. Simonian school, which he accordingly accomplished in his *Système de Politique Positive*. This work did not, however, meet with the approbation of St. Simon, who asserted that Comte had made a very important omission by overlooking the religious or sentimental part of human nature. In 1826 Comte commenced a course of lectures on positive philosophy, but only four lectures were given when he became deranged in mind, and did not recover till the end of 1827. In 1830 he commenced the publication of his *Cours de Philosophie Positive*, which was completed in six volumes in 1842, and was freely translated into English and condensed by Harriet Martineau (two vols. 1853). (See *Positive Philosophy*.) Some aspersions on his superiors at the *École Polytechnique*, where he held the posts of teacher and examiner, cost him his dismissal, and some English friends subscribed a temporary subsidy; and at a later period M. Littré organized a general subsidy, which afforded him a moderate degree of comfort in his later years. In 1845 he made the acquaintance of Clotilde de Vaux, who seems to have inspired him with a depth and tenderness of moral and æsthetic feeling before unknown in him. This appears in his second great work, *Positive Polity* (1851-54); the *Positivist Catechism* (1852); and his last work, *Subjective Synthesis* (1855). In his *Religion of Humanity* he himself assumed the office of high-priest, performing marriage and funeral rites on behalf of the disciples who had been induced to adopt his system. These, however, were never very numerous; and as a practical faith his system is now stationary, though as a philosophy of knowledge it is widely accepted. His works have been made known to English readers mainly by Mr. G. H. Lewes' *Comte's Philosophy of the Sciences* and Miss Martineau's translation above mentioned.

**Co'mus**, in the later Greek mythology, the god of revelry, feasting, and nocturnal entertainments, generally represented as a drunken youth. Milton's *Comus* is a creation of his own.

**Com'yn**, JOHN, Lord of Badenoch, was one of the commissioners sent to confer about the marriage of the Maid of Norway to Prince Edward of England. On the competition for the Scotch throne in 1291 Comyn put in a claim as a descendant of Donald Bane. The date of his death is

uncertain, but he was alive in 1299. His son, JOHN COMYN, called the 'Red Comyn,' was chosen one of the three guardians of Scotland, and defeated the English at Roslin in 1302. He submitted to Edward I. in 1314, and was killed by Bruce in the Convent of the Minorites at Dumfries in 1306.

**Con**, an Italian preposition signifying *with*, and of frequent occurrence in musical phraseology: *con amore*, with feeling; *con brio*, brilliantly; *con gusto*, with taste; &c.

**Cona'cre**, a term applied to a system common in Ireland, of underletting a portion of a farm for a single crop, the rent being paid to the farmer in money or in labour.

**Concan**, a maritime subdivision of Hindustan, in the presidency of Bombay. It consists of a long belt of sea-coast, stretching from north to south for about 220 miles, with an average breadth of 35 miles, and bounded on the east by the Western Ghauts. It includes the town and island of Bombay. Area about 12,500 sq. m.; pop. about 3,800,000.

**Concarneau** (kōn-kär-nō), a seaport, France, dep. Finistère, on an island in the bay of La Forêt. Sardine fishing; large piscicultural establishment. Pop. 4614.

**Concave**, hollow and curved or rounded, as the inner surface of a spherical body. A surface is *concave* when straight lines drawn from point to point in it fall between the surface and the spectator; and *convex* when the surface comes between him and such lines.

**Concentra'tion**, in chemistry, the act of increasing the strength of solutions. This is effected in different ways: by evaporating off the solvent, as is done in the separation of salt from sea-water; by distilling off the more volatile liquid, as in the rectification of spirit of wine; by the use of low temperatures, as in the purification of benzol; by difference of fusibility, as in Pattinson's process for desilvering lead.

**Concepcion'**, a seaport of Chili, capital of a province of the same name, on the right bank of the Biobio, 7½ miles from its mouth, a well-built town, with a cathedral. Its port at Talcahuano, a small town on the Bay of Concepcion, about 8 miles distant, is one of the best in Chili. Concepcion was founded in 1550, and has suffered much from earthquakes and attacks by the Araucanians. Pop. 19,000.

**Concep'tion**, the act or power of conceiving in the mind; in philosophy, that mental

act or combination of acts by which an absent object of perception is brought before the mind by the imagination.

**Conception**, **IMMACULATE**, in the Roman Catholic Church, the doctrine that the Virgin Mary was born without the stain of original sin. This doctrine came into favour in the 12th century, when, however, it was opposed by St. Bernard, and it afterwards became a subject of vehement controversy between the Scotists, who supported, and the Thomists, who opposed it. In 1708 Clement XI. appointed a festival to be celebrated throughout the church in honour of the immaculate conception. Since that time it was received in the Roman Church as an opinion, but not as an article of faith until the year 1854, when the pope issued a bull which makes the immaculate conception a point of faith.

**Concep'tualism**, in metaphysics, a doctrine in some sense intermediate between realism and nominalism. Conceptualism assigns to universals an existence which may be called logical or psychological, that is, independent of single objects, but dependent upon the mind of the thinking subject, in which they are as notions or conceptions.

**Con'cert**, a public or private musical entertainment, at which a number of vocalists or instrumentalists, or both, perform singly or combined.

**Concerti'na**, a musical instrument invented by Professor Wheatstone, the principle of which is similar to that of the accordion. It is composed of a bellows, with two faces or ends, generally polygonal in shape, on which are placed the various stops or studs, by the action of which air is admitted to the free metallic reeds which produce the sounds. In the English concertina the compass is three octaves and three notes. The German concertina is an inferior instrument.

**Concerto** (kon-cher'tō), in music, a kind of composition, usually in a symphonic form, written for one principal instrument, with accompaniments for a full orchestra.

**Concert Pitch.** See *Pitch*.

**Concession**, a permission conceded by a government to a person or company to do certain things; specially applied to grants of land, or privileges or immunities in connection with certain enterprises, such as mining, the construction of railways, canals, or the like, usually subject to fixed conditions and limitations.

**Conch** (kongk), a marine shell, especially

a large spiral shell of a trumpet shape, and which may be blown as a trumpet, as is the practice in Hindustan and some of the Pacific Islands.

**Conchifera** (kon-kif'è-ra), Lamarck's name for that large class of acephalous molluscs which have shells consisting of two pieces, commonly known as *bivalves* (oyster, mussel, &c.).

**Conchol'ogy**, the science of shells, that department of zoology which treats of the nature, formation, and classification of the shells with which the bodies of many mollusca are protected; or the word may be used also to include a knowledge of the animals themselves, in which case it is equivalent to *malacology*. In systems of conchology shells are usually divided into three orders, Univalves, Bivalves, and Multivalves, according to the number of pieces of which they are composed. See *Mollusca*.

**Con'clave**, the place where the cardinals assemble for the election of the pope; also the electoral assembly of the cardinals themselves. Pope Gregory X., whose election had been delayed for three years, established in the council at Lyons (1274) the regulations of the conclave. The cardinals are shut up together in a particular suite of apartments in the palace where the pontiff dies, and they are supposed to have no communication with the outside world during the period of the election. The companion, either lay or clerical, whom the cardinal is allowed to take with him into the conclave during the election of a pope is called a *conclavist*. The office is one of great delicacy and trust.

**Con'cord**, in music, the combination of two or more sounds pleasing to the ear. Concords are the octave, the fifth, third, and sixth. The two first are called *perfect*, because as concords they are not liable to any alteration by sharps or flats. The two last are called *imperfect*, as being alterable.

**Concord**, several places in the U. States, particularly the capital of New Hampshire, on the Merrimack, 60 miles N.N.W. Boston, one of the largest railway centres in New England. It has manufactures of carriages, hardware, cutlery, woollen fabrics, paper, &c. Pop. 1890, 17,004.

**Concor'dance**, a book in which the principal words used in any work or number of works, as the Scriptures, Shakspeare, Milton, Tennyson, Homer, &c., are arranged alphabetically, and the book, chapter, and verse, or act, scene, line, or other subdivision in

which each word occurs, are noted; designed to assist an inquirer in finding any passage by means of any leading word which he can recollect, or to show the character of the language and style of any writer. Some of the most approved concordances in English are those of the Bible by Cruden, Butterworth, Brown, and Taylor. Of non-biblical concordances, that of Mary Cowden Clarke to Shakspeare deserves especially to be mentioned.

**Concor'dat**, a convention between the pope, as head of the R. Catholic Church, and any secular government, for the settling of ecclesiastical relations. One of the most important of the earlier concordats, that of Worms, called also the *Calixtine Concordat*, made in 1122, between Pope Calixtus II. and the Emperor Henry V., has been regarded as the fundamental law of the church in Germany. Another celebrated concordat was that agreed upon between Cardinal Gonsalvi, in the name of Pius VII., and Napoleon in July, 1801. By it the head of the state had the nomination of bishops to the vacant sees; the clergy became subject in temporal matters to the civil power; all immunities, ecclesiastical courts, and jurisdictions were abolished in France, and even the regulations of the public worship and religious ceremonies and the pastoral addresses of the clergy, were placed under the control of the secular authorities. Most of these provisions remain in France at the present day. Since the middle of the 18th century concordats have generally been adverse to the power of the popes.

**Con'crete**, a technical term in logic, applied to an object as it exists in nature, invested with all its attributes, or to the notion of such an object. Concrete is opposite to abstract. The names of individuals are concrete; those of classes, abstract. A concrete name is a name which stands for a thing; an abstract name is a name which stands for the attribute of a thing.

**Con'crete**, a composition used in building, consisting of hydraulic or other mortar mixed with gravel or stone chippings about the size of a nut. It is used extensively in building under water, for example, to form the bottom of a canal or sluice, or the foundation of any structures raised in the sea; and it is also frequently used to make a bed for asphalt pavements, or to form foundations for buildings of any kind. It is sometimes even used as the material with which the walls of houses are built,

the concrete being firmly rammed into moulds of the requisite shape, and then allowed to set.

**Concre'tions**, MORBID, in animal economy, hard substances that occasionally make their appearance in different parts of the body, as well in the solids as in those cavities destined to contain fluids. They are usually named according to the parts of the body in which they occur, as *pineal, salivary, pancreatic, hepatic, pulmonary, urinary* concretions, &c. Their composition is equally various, but the most common constituents are phosphates, urates, or other salts, in combination with mucus, albumen, fibrin, and other organic matter. See *Calculus*.

**Concu'binage**, sexual cohabitation of a man without legal marriage. It was permitted among the ancient Hebrews and the Greeks without limitation; but among the Romans in the case of unmarried men concubinage was limited by the *Lex Julia* and *Lex Papia Poppæa* to a single concubine of mean descent.

**Concurrent Jurisdiction**, the jurisdiction of different courts authorized to take cognizance of the same kind of case. In criminal cases the court which first takes up a case has the right of prevention, that is, of deciding upon that case exclusive of the other courts which but for that right would have been equally entitled to take cognizance of it. In civil cases it lies with the suitor to bring his cause before any court he pleases, which is competent to take it up.

**Concussion of the Brain**, a term applied to certain injuries of the brain resulting from blows and falls, though unattended with fracture of the skull. Stupor or insensibility, sickness, impeded respiration, and irregular pulse are the first symptoms, and though these may subside there is always for a time more or less risk of serious inflammation of the brain setting in.

**Condamine**, CHARLES MARIE DE LA. See *La Condamine*.

**Condé** (kōn-dā), town and fortress of France, dep. Nord, at the confluence of the Hayne and Scheldt. It gave their title to the Condé family. Pop. 3382.—For another Condé see *Condé-sur-Noireau*.

**Condé**, LOUIS DE BOURBON, founder of the house of, born 1530; killed after battle of Jarmac, 1569. See *Bourbon*.

**Condé**, LOUIS DE BOURBON, PRINCE OF (the *Great Condé*), a famous general, born in 1621. In 1641 he married a niece of

Cardinal Richelieu. His defeat of the Spanish at Rocroi, in 1643, was followed, in 1645, by his defeat of Mercy at Nordlingen, and by his capture of Dunkirk in 1646, the year in which he inherited his father's title. During the troubles of the Fronde he at first took the side of the court; but believing himself to be ill requited by Mazarin, he put himself at the head of the faction of the *Petits Maîtres*, and was imprisoned for a year by Mazarin (1650). On his release he at once put himself at the head of a new Fronde, entered upon negotiations with Spain, and, his attack on Paris being indecisive, retired to the Netherlands, where he was appointed generalissimo of the Spanish armies. In this capacity he unsuccessfully besieged Arras in 1654; but he was more fortunate at Valenciennes in 1656, and at Cambrai in 1657. In 1658 he was defeated before Dunkirk by Turenne, but was restored to his rank in France after the peace of 1659. In 1668 he accomplished the reduction of Franche Comté in three weeks; and in 1674 he defeated the Prince of Orange at Senef. His successes over Montecuculi in Alsace in 1675 closed his military career. Four years later he retired to Chantilly, near Paris, and died at Fontainebleau in 1687.

**Condé**, LOUIS JOSEPH DE BOURBON, PRINCE OF, born at Chantilly in 1736; only son of the Duke of Bourbon and the Princess of Hesse-Rheinfels. He distinguished himself in the Seven Years' war, and in 1762 defeated the Prince of Brunswick at Johnnisberg. On the outbreak of the revolution in 1789 he emigrated, and in 1792 formed, at Worms, a corps of emigrant nobility, which first joined the Austrian, and in 1795 the English service. In 1797 he entered the Russian service, but in 1800, after the separation of Russia from the coalition, re-entered for a time the English army. He lived in England till 1813, returned to Paris in 1814, received various honours, and attended the king in his flight to Ghent. On his return he was appointed president of a bureau of the chamber of peers, but soon after retired to Chantilly. He died at Paris in 1818.

**Condensa'tion**, in chemistry and physics, the act of reducing a gas or vapour to a liquid or solid form. *Surface condensation*, a mode of condensing steam by bringing it in contact with cold metallic surfaces in place of by injecting cold water.

**Condensed Milk**, milk preserved by eva-

porating part of its moisture, mixing with refined powdered sugar, and packing in airtight cans hermetically sealed: the sugar may also be omitted.

**Condens'er**, a syringe by which air is compressed into a receiver. Also a vessel in which aqueous or other vapours are condensed by cooling into the liquid form.

**Condensing Steam-engine**. See *Steam-engine*.

**Condescen'dence**, in Scots law, one of the written pleadings in a process put in by the pursuer, and containing a distinct statement of the facts and allegations, together with the pleas in law on which his case is founded.

**Condé-sur-Noireau** (kōñ-dā-sūr-nwä-rō), a town, France, dep. Calvados, at the confluence of the Noireau and Drouance. Chief manufacture, cotton. Pop. 7279.

**Condillac** (kōñ-dē-yāk), ÉTIENNE BONNOT DE, French philosopher, born in 1715. His *Essai sur l'Origine des Connaissances Humaines* (1746), in large part a polemic against abstract methods of philosophizing, struck the key-note of his system, and his *Traité des Systèmes* (1749) continued the condemnation of all systems not evolved from experience, from sensation. In 1754 appeared his *Traité des Sensations*, and in 1755 his *Traité des Animaux*, a criticism on Buffon. The sagacity and clearness of his writings led to his appointment as tutor to the nephew of Louis XV., the infant Duke of Parma, for whom he wrote in 1755 his *Cours d'Études*, including a grammar, an *Art d'Écrire*, an *Art de Reasonner*, an *Art de Penser*, and a general history. His work *Le Commerce et le Gouvernement* appeared in the same year as the *Wealth of Nations* (1776), and was no unworthy companion to it. In 1768 he was elected to the Academy. He died shortly after the publication of his *Logic* in 1780, his *Langue des Calculs* being published posthumously in 1798.

**Conditioned and Unconditioned**, in philosophy, terms introduced by Sir William Hamilton. The Unconditioned is regarded by Sir William Hamilton as a genus including two species: the Infinite, or the unconditionally unlimited, and the Absolute, or the unconditionally limited; and the thesis which he maintains and expounds, and which forms one of the leading doctrines of his philosophical system, is that the Unconditioned, as thus explained, is entirely unthinkable. The mind is confined, in point of knowledge though not of faith to the limited and conditioned—the Conditioned being the mean be-

tween two unconditionates, mutually exclusive and equally inconceivable, but of which, on the principles of contradiction and excluded middle, *one must be admitted as necessary*. Thus infinite space is inconceivable by us, while at the same time it is equally impossible to us to conceive of space as finite; yet one of these must be admitted necessary, and our conception is in some sense a mean between the inconceivables. The doctrine was applied by Mansel to determine the limits of religious thought.

**Condom** (koŋ-dōŋ), a town of S.W. France, dep. Gers, on a height above the Baïse. It has a dilapidated cathedral, now the parish church. A considerable trade is carried on. Pop. 8553.

**Condonation**, in law, forgiveness of injury. In an action for divorce on the ground of adultery it is a legal plea in defence.

**Con'dor** (Spanish name, from Peruvian *cuntur*), a South American bird, the *Sarcorhamphus gryphus*, one of the largest of the Vulturidæ or vulturine birds. In its essential features it resembles the common vultures, differing from them mainly in the



Condor (*Sarcorhamphus gryphus*).

large cartilaginous caruncle which surmounts its beak, and in the large size of its oval and longitudinal nostrils placed almost at the extremity of the cere. Despite the many stories of its gigantic proportions, Humboldt met with no specimens whose wings exceeded 9 feet in expanse, though it has occasionally been known to attain an expanse of 14 feet. It is found in greatest numbers in the Andes chain, frequenting regions from 10,000 to 15,000 feet above the level of the sea, where they breed, depositing their two white eggs on the bare rock. They are generally to be seen in groups of three or four, and only descend to

the plains under stress of hunger, when they will successfully attack sheep, goats, deer, and bullocks. They prefer carrion, however, and, when they have opportunity, gorge themselves until they become incapable of rising from the ground, and so become a prey to the Indians. The king-vulture (*S. Papa*) is another bird of the same genus.

**Condorcet** (koŋ-dor-sā), MARIE JEAN ANTOINE NICOLAS DE CARITAT, MARQUIS DE, an eminent French writer, born in 1743. At the age of twenty-one he presented to the Academy of Sciences an *Essai sur le Calcul Intégral*, and in 1767 his *Mémoire sur le Problème des Trois Points* appeared, both being afterwards united under the title of *Essais d'Analyse*. The merit of this work gained for him in 1769 a seat in the Academy of Sciences, of which, after the publication of his *Éloges des Académiciens morts avant 1689* (1773), he was appointed perpetual secretary (1777). In 1777 his *Theory of Comets* gained the prize offered by the Academy of Berlin; he enriched the *Transactions* of many learned societies; and took an active part in the *Encyclopédie*. During the troubles of the first French revolution his sympathies were strongly engaged on the side of the people. By the city of Paris he was elected deputy to the legislative assembly, of which he was soon appointed secretary, and in February, 1792, president. On the trial of Louis he was in favour of the severest sentence not capital; at the same time he proposed to abolish capital punishments, except in case of crimes against the state. The fall of the Girondist party, May 31, 1793, prevented the constitution which Condorcet had drawn up from being accepted, and as he freely criticised the constitution which took its place he was denounced as being an accomplice of Brissot. Madame Verney, a woman of noble feelings, secreted him for eight months, during which he wrote his *Esquisse d'un Tableau Historique des Progrès de l'Esprit Humain*. Lest he should endanger her safety, however, he left the house secretly in opposition to her wishes, fled from Paris, and wandered about till arrested and thrown into prison, where, March 28, 1794, he was found dead on the floor, having apparently swallowed poison.

**Condottieri** ('on-dot-tē ā'rē), an Italian name given to the captains of those bands of mercenary soldiers who, in the 14th and 15th centuries, hired themselves out to carry

on the petty wars of the Italian states. Montreal d'Albarno, a gentleman of Provence, was the first to give definite organization to a lawless band of this kind, and many of them attained a considerable size and power. One of the most noted was the company of Sforza Attendolo, whose son made himself duke of Milan. For the most part these mercenaries were good soldiers and splendidly equipped, but rapacious and cruel to all but their own class.

**Conduction.** See *Heat*.

**Conduc'tor**, or LIGHTNING CONDUCTOR, an instrument by means of which either the

adoption, the first conductor in England being erected in 1762. It usually consists of a stout iron rod with one or more points at the top, the lower end being metallically connected with thick strips of copper which are carried into the ground to a considerable depth and terminated, if possible, in water or in wet earth. Various other forms of conductors have been introduced, such as are shown in the accompanying cut, where *a* is a conductor consisting of metallic strips joined together, *b* a conductor of copper wires intertwined with iron rods, *e* a conductor consisting of a metallic strip forming a tube with spiral flanges. Various kinds of tips are also in use, as will be seen in the cut, *d* being formed of several metals inclosed the one within the other, the most fusible being outside; *g, h, i* show how in some cases successive sections of rods are connected.

**Conduit** (kun'dit), a line of pipes or an underground channel of some kind for the conveyance of water.

**Con'dyle** (Gr. *kondylos*), in anat. a protuberance on the end of a bone serving to form an articulation with another bone: more especially applied to the prominence of the occipital bone for articulation with the spine.

**Condy's Fluid**, a preparation of permanganate of potash which is largely used as a deodorizer and disinfectant in fevers, &c. It is also employed as a gargle in diphtheria and other throat affections, and is especially valuable for cleansing ulcers and sores.

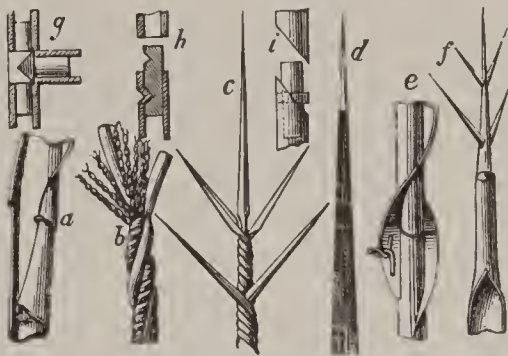

Lightning-conductor.

*abe*, Various forms of Rods. *cdf*, Various forms of Tips.  
*ghi*, Various forms of Attachments.

electricity of the clouds, the cause of lightning, is conducted without explosion into the earth, or the lightning itself is received and conducted quietly into the earth or water without injuring buildings, ships, &c. It was invented by Benjamin Franklin about 1752, and met with speedy general













LIBRARY OF CONGRESS

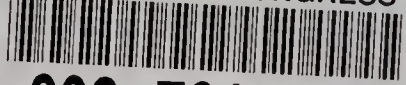

0 038 701 439 1