

4-18-94  
Vol. 59 No. 74

Monday  
April 18, 1994

# Federal Register

United States  
Government  
Printing Office

SUPERINTENDENT  
OF DOCUMENTS  
Washington, DC 20402

\*\*\*\*\*3-DIGIT

481

SECOND CLASS NEWSPAPER

Postage and Fees Paid  
U.S. Government Printing Office  
(ISSN 0097-6326)

OFFICIAL BUSINESS  
Penalty for private use, \$300

A FR UMISE346U DEC 94 R  
UMI SERIALS ACQUISITIONS  
300 N ZEEB RD  
PO BOX 1346  
ANN ARBOR MI 48106

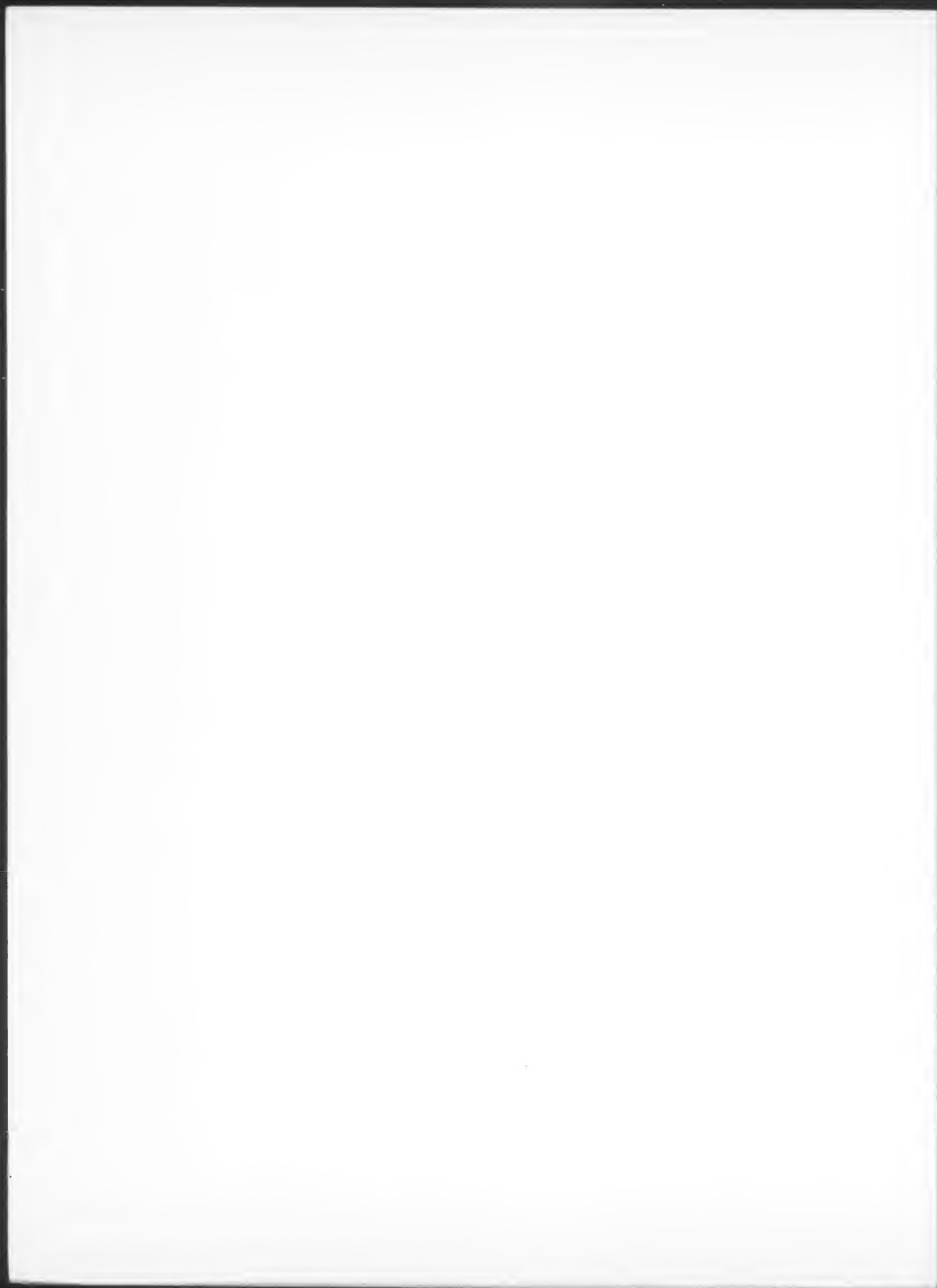

4-18-94  
Vol. 59 No. 74  
Pages 18291-18470

---

---

Monday  
April 18, 1994

# Federal Register

**Briefings on How To Use the Federal Register**  
For information on briefings in Washington, DC and Boston, MA, see announcement on the inside cover of this issue.



**FEDERAL REGISTER** Published daily, Monday through Friday, (not published on Saturdays, Sundays, or on official holidays), by the Office of the Federal Register, National Archives and Records Administration, Washington, DC 20408, under the Federal Register Act (49 Stat. 500, as amended; 44 U.S.C. Ch. 15) and the regulations of the Administrative Committee of the Federal Register (1 CFR Ch. I). Distribution is made only by the Superintendent of Documents, U.S. Government Printing Office, Washington, DC 20402.

The **Federal Register** provides a uniform system for making available to the public regulations and legal notices issued by Federal agencies. These include Presidential proclamations and Executive Orders and Federal agency documents having general applicability and legal effect, documents required to be published by act of Congress and other Federal agency documents of public interest. Documents are on file for public inspection in the Office of the Federal Register the day before they are published, unless earlier filing is requested by the issuing agency.

The seal of the National Archives and Records Administration authenticates this issue of the **Federal Register** as the official serial publication established under the Federal Register Act. 44 U.S.C. 1507 provides that the contents of the **Federal Register** shall be judicially noticed.

The **Federal Register** is published in paper and 24x microfiche format. The annual subscription price for the **Federal Register** paper edition is \$444, or \$490 for a combined **Federal Register**, Federal Register Index and List of CFR Sections Affected (LSA) subscription; the microfiche edition of the **Federal Register** including the Federal Register Index and LSA is \$403. Six month subscriptions are available for one-half the annual rate. The charge for individual copies in paper form is \$6.00 for each issue, or \$6.00 for each group of pages as actually bound; or \$1.50 for each issue in microfiche form. All prices include regular domestic postage and handling. International customers please add 25% for foreign handling. Remit check or money order, made payable to the Superintendent of Documents, or charge to your GPO Deposit Account, VISA or MasterCard. Mail to: New Orders, Superintendent of Documents, P.O. Box 371954, Pittsburgh, PA 15250-7954.

There are no restrictions on the republication of material appearing in the **Federal Register**.

**How To Cite This Publication:** Use the volume number and the page number. Example: 59 FR 12345.

## SUBSCRIPTIONS AND COPIES

### PUBLIC

#### Subscriptions:

Paper or fiche 202-783-3238  
Assistance with public subscriptions 512-2303

#### Single copies/back copies:

Paper or fiche 783-3238  
Assistance with public single copies 512-2457

### FEDERAL AGENCIES

#### Subscriptions:

Paper or fiche 523-5243  
Assistance with Federal agency subscriptions 523-5243

For other telephone numbers, see the Reader Aids section at the end of this issue.

## THE FEDERAL REGISTER WHAT IT IS AND HOW TO USE IT

- FOR:** Any person who uses the Federal Register and Code of Federal Regulations.
- WHO:** The Office of the Federal Register.
- WHAT:** Free public briefings (approximately 3 hours) to present:
1. The regulatory process, with a focus on the Federal Register system and the public's role in the development of regulations.
  2. The relationship between the Federal Register and Code of Federal Regulations.
  3. The important elements of typical Federal Register documents.
  4. An introduction to the finding aids of the FR/CFR system.
- WHY:** To provide the public with access to information necessary to research Federal agency regulations which directly affect them. There will be no discussion of specific agency regulations.

### WASHINGTON, DC

- WHEN:** April 20 at 9:00 am  
**WHERE:** Office of the Federal Register, 7th Floor Conference Room, 800 North Capitol Street NW, Washington, DC (3 blocks north of Union Station Metro)
- RESERVATIONS:** 202-523-4538

### BOSTON, MA

- WHEN:** May 3 at 9:00 am  
**WHERE:** Room 419 Barnes Federal Building 495 Summer Street Boston, MA
- RESERVATIONS:** Call the Federal Information Center 1-800-347-1997



# Contents

Federal Register

Vol. 59, No. 74

Monday, April 18, 1994

## Administration on Aging

See Aging Administration

## Agency for Health Care Policy and Research

### NOTICES

#### Meetings:

Health Care Policy, Research, and Evaluation National Advisory Council, 18411-18412

## Aging Administration

### NOTICES

Agency information collection activities under OMB review, 18412

## Agriculture Department

See Rural Electrification Administration

## Army Department

See Engineers Corps

### NOTICES

#### Meetings:

Science Board, 18372-18373

## Arts and Humanities, National Foundation

See National Foundation on the Arts and the Humanities

## Bonneville Power Administration

### NOTICES

Non-Federal participation capacity ownership record of decision; availability, 18374-18375

## Civil Rights Commission

### NOTICES

Meetings; State advisory committees:

Michigan, 18356

Minnesota, 18356

## Coast Guard

### RULES

Drawbridge operations:  
Illinois, 18298-18300

## Commerce Department

See Export Administration Bureau

See International Trade Administration

See National Oceanic and Atmospheric Administration

See Patent and Trademark Office

## Committee for the Implementation of Textile Agreements

### NOTICES

Export visa requirements; certification, waivers, etc.:

Philippines; correction, 18372

## Comptroller of the Currency

### PROPOSED RULES

Capital adequacy; net unrealized holding gains and losses on available-for-sale securities, 18328-18329

## Defense Department

See Army Department

See Engineers Corps

## Employment and Training Administration

### NOTICES

Grants and cooperative agreements; availability, etc.:

Job Training Partnership Act--

Learning consortia project, 18416-18421

## Energy Department

See Bonneville Power Administration

See Energy Efficiency and Renewable Energy Office

See Federal Energy Regulatory Commission

See Hearings and Appeals Office, Energy Department

## Energy Efficiency and Renewable Energy Office

### RULES

Energy conservation:

New Federally-owned buildings energy performance standards; standby loss criteria, minimum performance loss for electric, gas, and oil storage water heaters, 18293-18294

## Engineers Corps

### NOTICES

Environmental statements; availability, etc.:

Pierce County, WA; municipal solid-waste landfill, 18373-18374

Meetings:

Coastal Engineering Research Board, 18374

## Environmental Protection Agency

### RULES

Air quality implementation plans; approval and promulgation; various States:

Tennessee, 18310-18317

Virgin Islands, 18307-18310

Air quality implementation plans; approval and promulgation; various States; and air quality planning purposes; designation of areas:

North Carolina, 18300-18307

### PROPOSED RULES

Air quality implementation plans; approval and promulgation; various States:

Arizona, 18346-18348

Utah, 18341-18346

Hazardous waste:

Identification and listing--

Carbamate production, 18348

### NOTICES

Agency information collection activities under OMB review, 18392-18393

Meetings:

Environmental Policy and Technology National Advisory Council, 18393

Superfund; response and remedial actions, proposed settlements, etc.:

Lee Chemical Co. Site, MO, 18398-18399

Toxic and hazardous substances control:

Ethyl tert-butyl ether and tertiary-amyl methyl ether; testing negotiations participation opportunity, 18399-18400

Premanufacture notices receipts, 18393-18398, 18400-18409

**Executive Office of the President**

See Presidential Documents

**Export Administration Bureau****NOTICES**

## Meetings:

Regulations and Procedures Technical Advisory Committee, 18357

**Federal Aviation Administration****RULES**

## Airworthiness directives:

Boeing, 18294-18296

Jet routes, 18296

**PROPOSED RULES**

## Air carrier certification and operations:

Operator flight attendant English language program, 18456-18457

Offshore airspace areas, 18329-18830

**NOTICES**

## Advisory circulars; availability, etc.:

Aircraft—

Flight attendant seat and torso restraint system installations, 18438

Smoke detection, penetration, and evacuation tests and related flight manual emergency procedures, 18438

Transport category airplanes—

Cargo service modification, 18438

**Federal Communications Commission****RULES**

## Common carrier services:

Calling number identification (caller ID); interstate calls, 18318-18320

**PROPOSED RULES**

## Common carrier services:

Calling number identification (caller ID); interstate calls, 18349-18350

**NOTICES**

Meetings; Sunshine Act, 18442

Rulemaking proceedings; petitions filed, granted, denied, etc., 18409

**Federal Deposit Insurance Corporation****NOTICES**

## Privacy Act:

Systems of records, 18409

**Federal Energy Regulatory Commission****NOTICES**

## Electric rate and corporate regulation filings:

Florida Municipal Power Agency et al., 18375-18377  
PacifiCorp et al., 18377-18379

## Environmental statements; availability, etc.:

Mojave Pipeline Co., 18379-18381

Hydroelectric applications, 18381-18387

Meetings; Sunshine Act, 18442

## Natural gas certificate filings:

K N Wattenberg Transmission Ltd. Liability Co. et al., 18387-18388

TCP Gathering Co. et al., 18388-18389

*Applications, hearings, determinations, etc.:*

ANR Pipeline Co., 18389

Entergy Services, Inc., 18390

National Fuel Gas Supply Corp., 18390

Questar Pipeline Co., 18390

Williams Natural Gas Co., 18390

**Federal Maritime Commission****PROPOSED RULES**

Ocean freight forwarders, marine terminal operations, and passenger vessels:

Financial responsibility requirements for transportation nonperformance

Correction, 18443

**Federal Mine Safety and Health Review Commission****NOTICES**

Meetings; Sunshine Act, 18442

**Federal Reserve System****NOTICES***Applications, hearings, determinations, etc.:*

First Midwest Corp. of Delaware, 18409-18410

Keystone Finance, Inc., et al., 18410

Marantz, Jack A., et al., 18410-18411

Mellon Bank Corp., 18411

**Fish and Wildlife Service****RULES**

## Endangered and threatened species:

Saint Francis' satyr, 18324-18327

**PROPOSED RULES**

## Endangered and threatened species:

Findings on petitions, etc., 18353-18354

Saint Francis' satyr, 18350-18353

**Food and Drug Administration****RULES**

## Animal drugs, feeds, and related products:

Laidlomycin propionate potassium, 18296-18297

**NOTICES**

## Food additive petitions:

Shell Oil Co., 18412

## Medical devices; premarket approval:

Jersey LCS Total Knee System Rotating Platform

Configuration, 18412-18413

NDS System, 18413-18414

**Health and Human Services Department**

See Agency for Health Care Policy and Research

See Aging Administration

See Food and Drug Administration

See Health Care Financing Administration

See Health Resources and Services Administration

**NOTICES**

## Organization, functions, and authority delegations:

Assistant Secretary for Health; order of succession, 18414

**Health Care Financing Administration****RULES**

## Medicare program:

Rehabilitation program; condition of participation; CFR correction, 18318

**Health Resources and Services Administration****NOTICES**

## Meetings; advisory committees:

May, 18414

June, 18414

**Hearings and Appeals Office, Energy Department****NOTICES**

Cases filed, 18391-18392

**Indian Affairs Bureau****PROPOSED RULES****Education:**

Higher education grant program, 18460-18463

**Interior Department**

See Fish and Wildlife Service

See Indian Affairs Bureau

See Land Management Bureau

See Surface Mining Reclamation and Enforcement Office

**Internal Revenue Service****NOTICES****Taxable substances, imported:**

Acrylonitrile-butadiene-styrene (ABS) pellets; withdrawn, 18439

Alpha methyl styrene polymer, etc.; withdrawn, 18439

Di-2 ethyl hexyl phthalate, 18439-18440

Polycarbonate, 18440

Sodium nitriolotriacetate monohydrate, etc., 18440-18441

**International Trade Administration****NOTICES****Countervailing duties:**

Grain-oriented electrical steel from—

Italy, 18357-18370

**Applications, hearings, determinations, etc.:**

California Institute of Technology, 18370

LSU and A&M College et al., 18370-18371

**Interstate Commerce Commission****NOTICES****Agency information collection activities under OMB**

review, 18416

**Agreements under sections 5a and 5b; applications for approval, etc.:**

EC-MAC Motor Carriers Service Association, Inc., 18416

**Labor Department**

See Employment and Training Administration

See Occupational Safety and Health Administration

**NOTICES****Future of Worker-Management Relations Commission; public record closure, 18416****Land Management Bureau****NOTICES****Realty actions; sales, leases, etc.:**

California, 18415

Nevada, 18415

**Resource management plans, etc.:**

Grand Resource Area, UT, 18415-18416

**Mine Safety and Health Federal Review Commission**

See Federal Mine Safety and Health Review Commission

**National Archives and Records Administration****NOTICES****Committees; establishment, renewal, termination, etc.:**

Presidential Libraries Advisory Committee, 18422-18423

**National Foundation on the Arts and the Humanities****NOTICES****Meetings:**

International Exhibitions Federal Advisory Committee, 18423

**National Highway Traffic Safety Administration****RULES****Motor vehicle safety standards:**

Air and hydraulic brake systems—

Automatic brake adjusters, 18320-18323

**National Oceanic and Atmospheric Administration****NOTICES****Meetings:**

Gulf of Mexico Fishery Management Council, 18371

Mid-Atlantic Fishery Management Council, 18371-18372

Monterey Bay National Marine Sanctuary Advisory Council, 18372

**National Science Foundation****NOTICES****Meetings:**

Biological and Critical Systems Special Emphasis Panel, 18423

Engineering Education and Centers Special Emphasis Panel, 18423

Social, Behavioral, and Economic Research Special Emphasis Panel, 18423

**Nuclear Regulatory Commission****NOTICES****Agency information collection activities under OMB review, 18424****Environmental statements; availability, etc.:**

Florida Power & Light Co., 18424-18426

**Meetings:**

Constraint effects in fracture mechanics, 18426

**Operating licenses, amendments; no significant hazards considerations; biweekly notices; correction, 18426****Uranium mill tailing sites, reclamation plans; license amendment requests:**

Umetco Minerals Corp., 18426

**Occupational Safety and Health Administration****PROPOSED RULES****Safety and health standards, etc.:**

Indoor air quality; occupational exposure to pollutants, including tobacco smoke

Correction, 18443

**NOTICES****State plans; standards approval, etc.:**

Utah, 18422

**Panama Canal Commission****PROPOSED RULES****Shipping and navigation:**

Canal tolls and vessel measurement rules, 18332-18341

**Patent and Trademark Office****RULES****Patent cases:**

Reissue oath or declaration; CFR correction, 18300

**Physician Payment Review Commission****NOTICES****Meetings, 18426-18427****Postal Service****RULES**

Board of Governors bylaws; amendments, 18446-18454

**Presidential Documents****PROCLAMATIONS**

Death of passengers aboard helicopters shot down by friendly fire in Iraq (Proc. 6671), 18469

**Special observances:**

National Park Week (Proc. 6670), 18467

**EXECUTIVE ORDERS**

Committees; establishment, renewal, terminations, etc.:  
Science and Technology, President's Committee of Advisors on; membership addition (EO 12907), 18291

**Public Health Service**

See Agency for Health Care Policy and Research  
See Food and Drug Administration  
See Health Resources and Services Administration

**Rural Electrification Administration****NOTICES**

Grants and cooperative agreements; availability, etc.:  
Distance learning and medical link program, 18355-18356

**Securities and Exchange Commission****NOTICES**

Self-regulatory organizations; proposed rule changes:  
American Stock Exchange, Inc., 18429-18433  
Chicago Board Options Exchange, Inc.; correction, 18443  
National Association of Securities Dealers, Inc., 18433-18437  
Options Clearing Corp., 18427-18429  
Self-regulatory organizations; unlisted trading privileges:  
Pacific Stock Exchange, Inc., 18437-18438  
Philadelphia Stock Exchange, Inc., 18438

**Surface Mining Reclamation and Enforcement Office****PROPOSED RULES**

Permanent program and abandoned mine land reclamation plan submissions:  
Indiana, 18330-18332

**Textile Agreements Implementation Committee**

See Committee for the Implementation of Textile Agreements

**Transportation Department**

See Coast Guard

See Federal Aviation Administration

See National Highway Traffic Safety Administration

**Treasury Department**

See Comptroller of the Currency  
See Internal Revenue Service

**NOTICES**

Boycotts, international:  
Countries requiring cooperation; list, 18439

**Veterans Affairs Department****NOTICES**

Real property; enhanced-use leases:  
Minneapolis, MN; Veterans Affairs Medical Center, 18441

**Separate Parts In This Issue****Part II**

Postal Service, 18446-18454

**Part III**

Department of Transportation, Federal Aviation Administration, 18456-18457

**Part IV**

Department of the Interior, Bureau of Indian Affairs, 18460-18463

**Part V**

The President, 18465-18470

**Reader Aids**

Additional information, including a list of public laws, telephone numbers, and finding aids, appears in the Reader Aids section at the end of this issue.

**Electronic Bulletin Board**

Free **Electronic Bulletin Board** service for Public Law numbers and **Federal Register** finding aids is available on 202-275-1538 or 275-0920.



**CFR PARTS AFFECTED IN THIS ISSUE**

A cumulative list of the parts affected this month can be found in the Reader Aids section at the end of this issue.

<b>3 CFR</b>		<b>47 CFR</b>	
Executive Orders:		64.....	18318
12907.....	18291	Proposed Rules:	
Proclamations:		64.....	18349
6670.....	18467	<b>49 CFR</b>	
6671.....	18469	571.....	18320
<b>10 CFR</b>		<b>50 CFR</b>	
435.....	18293	17.....	18324
<b>12 CFR</b>		Proposed Rules:	
Proposed Rules:		17 (2 documents).....	18350, 18353
3.....	18328		
<b>14 CFR</b>			
39.....	18294		
71.....	18296		
Proposed Rules:			
71.....	18329		
121.....	18456		
125.....	18456		
135.....	18456		
<b>21 CFR</b>			
558.....	18296		
<b>25 CFR</b>			
Proposed Rules:			
40.....	18460		
<b>29 CFR</b>			
Proposed Rules:			
1910.....	18443		
1915.....	18443		
1926.....	18443		
1928.....	18443		
<b>30 CFR</b>			
Proposed Rules:			
914.....	18330		
<b>33 CFR</b>			
117.....	18298		
<b>35 CFR</b>			
Proposed Rules:			
133.....	18332		
135.....	18332		
<b>37 CFR</b>			
1.....	18300		
<b>39 CFR</b>			
1.....	18446		
2.....	18446		
3.....	18446		
3.....	18446		
4.....	18446		
5.....	18446		
6.....	18446		
7.....	18446		
8.....	18446		
11.....	18446		
221.....	18446		
<b>40 CFR</b>			
52 (3 documents).....	18300, 18307, 18310		
81.....	18300		
Proposed Rules:			
52.....	18341, 18346		
261.....	18348		
271.....	18348		
302.....	18348		
<b>42 CFR</b>			
405.....	18318		
<b>46 CFR</b>			
Proposed Rules:			
540.....	18443		

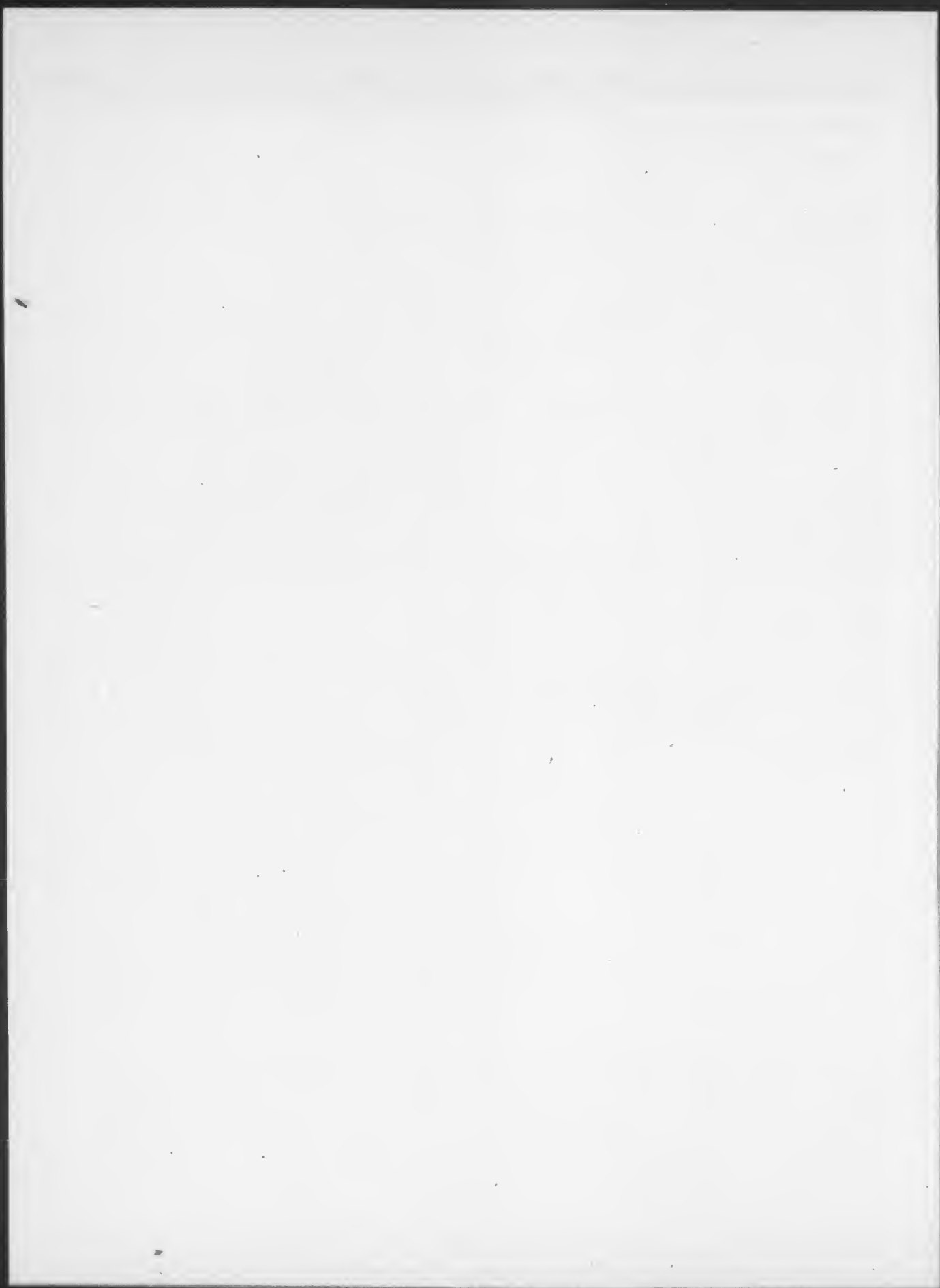

---

Federal Register

Vol. 59, No. 74

Monday, April 18, 1994

---

## Presidential Documents

Title 3—

Executive Order 12907 of April 14, 1994

The President

Amending Executive Order No. 12882

By the authority vested in me as President by the Constitution and the laws of the United States of America, and in order to add three members to the President's Committee of Advisors on Science and Technology, it is hereby ordered that the number "16" in the second sentence of section 1 of Executive Order No. 12882 is deleted and the number "19" is inserted in lieu thereof, and that the number "15" in the second sentence of section 1 of Executive Order No. 12882 is deleted and the number "18" is inserted in lieu thereof.

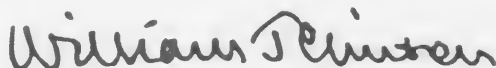

THE WHITE HOUSE,  
April 14, 1994.

[FR Doc. 94-9419

Filed 4-14-94; 2:03 pm]

Billing code 3195-01-P

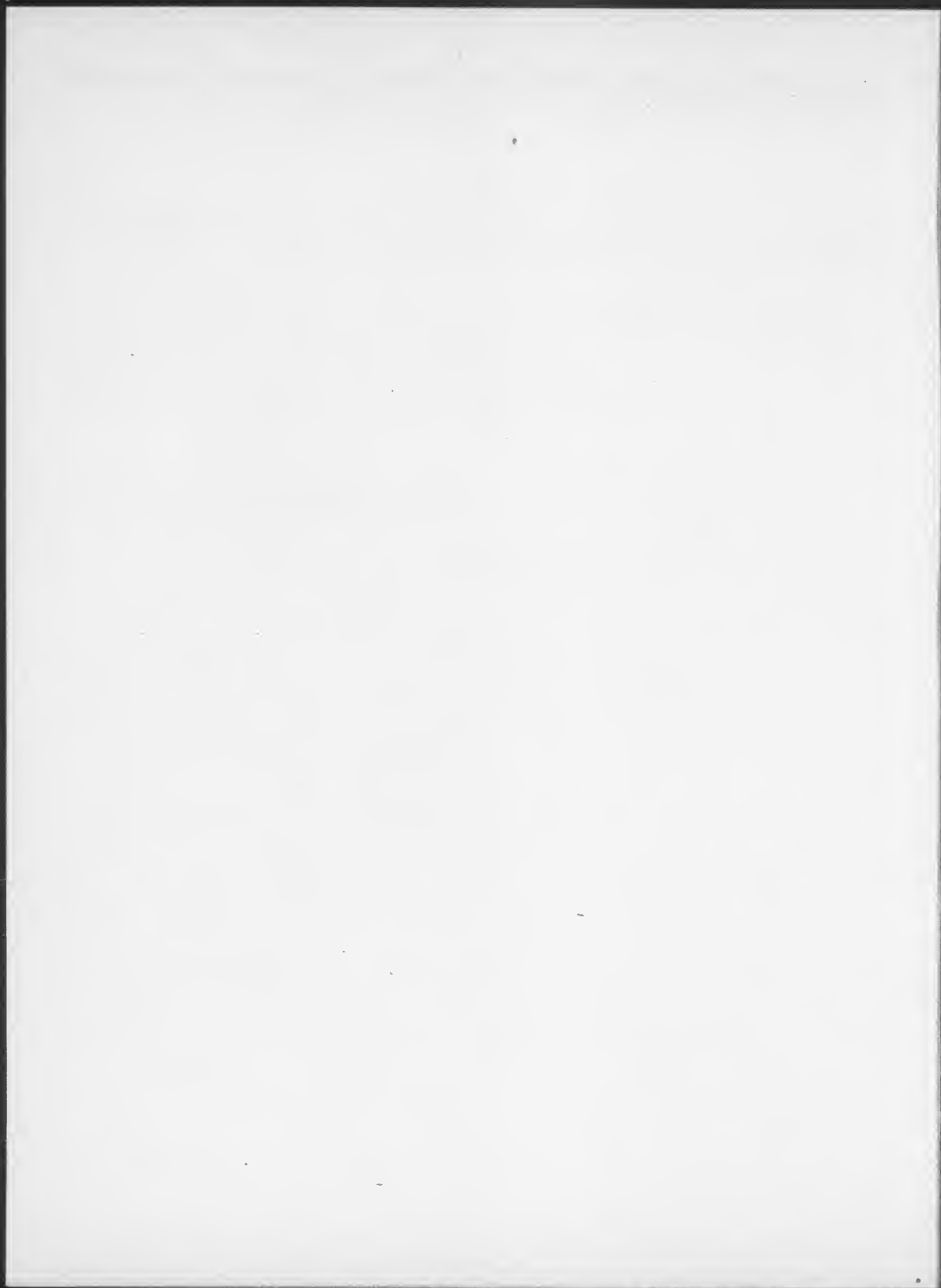

# Rules and Regulations

Federal Register

Vol. 59, No. 74

Monday, April 18, 1994

This section of the FEDERAL REGISTER contains regulatory documents having general applicability and legal effect, most of which are keyed to and codified in the Code of Federal Regulations, which is published under 50 titles pursuant to 44 U.S.C. 1510.

The Code of Federal Regulations is sold by the Superintendent of Documents. Prices of new books are listed in the first FEDERAL REGISTER issue of each week.

## DEPARTMENT OF ENERGY

### Office of Energy Efficiency and Renewable Energy

#### 10 CFR Part 435

[Docket No. CAS-RM-79-112-C]

#### Energy Conservation Voluntary Performance Standards for New Commercial and Multi-Family High Rise Residential Buildings; Mandatory for New Federal Buildings

AGENCY: Office of Energy Efficiency and Renewable Energy, DOE.

ACTION: Final rules; Removal.

SUMMARY: Pursuant to a court order, the Department of Energy today removes a portion of the interim commercial building energy performance standards from new Federally-owned buildings which set forth Standby Loss Criteria, Minimum Performance "Loss" for electric, gas and oil storage water heaters.

EFFECTIVE DATE: May 18, 1994.

ADDRESSES: Written comments and statements shall be sent to: Department of Energy, Office of Energy Efficiency and Renewable Energy, Mail Stop EE-432, room 5E-066, Forrestal Building, 1000 Independence Avenue, SW., Washington, DC 20585, (202) 586-7935.

FOR FURTHER INFORMATION CONTACT: Ronald B. Majette, U.S. Department of Energy, Office of Energy Efficiency and

Renewable Energy, Room 5E-066, 1000 Independence Avenue, SW., Washington, DC 20585, (202) 586-7935.

Eugene Margolis, Esq., Office of General Counsel, GC-72, U.S. Department of Energy, Room 6B-256, 1000 Independence Avenue, SW., Washington, DC 20585, (202) 586-9507.

SUPPLEMENTARY INFORMATION: Under the Energy Conservation Standards for New Buildings Act of 1976, 42 U.S.C. 6831-40 (1988), the Department of Energy issued interim energy performance standards that were binding for the design of new Federally-owned buildings. 10 CFR part 435. A portion of the interim standards set forth "standby loss" rules to limit those losses in water heaters installed in new federal construction projects.

Following publication of the interim standards, the Gas Appliance Manufacturers Association filed a lawsuit challenging the "Standby Loss" criteria in the United States District Court for the District of Columbia.

In *Gas Appliance Manufacturers Ass'n v. Secretary of Energy*, 722 F. Supp. 792 (D.D.C. 1989), the court set the standards aside. It enjoined enforcement of the "Standby Loss" rules and remanded the case for the Department to develop a statement of reasons and then to issue its final rule.

On remand, the Department published a "Preliminary Statement of Reasons for Adoption of Standby Loss Criteria," 54 FR 49,724, November 30, 1989, as corrected, 54 FR 50,341, December 6, 1989. The Association then filed a second lawsuit against the Department. The District Court upheld the "Standby Loss" criteria. 773 F. Supp. 461 (D.D.C. 1991). The Association appealed. The Court of Appeals reversed and remanded the matter to the District Court. *Gas Appliance Manufacturers Ass'n, vs. Department of Energy*, 998 F. 2d 1041 (D.C. Cir 1993). With that decision

having now become final, the Department is removing the "Standby Loss" rules from the Code of Federal Regulations.

The Storage Water Heater Standby Loss Criteria in question are part of § 435.109 of the interim standards, entitled "Service Water Heating Systems," published at 54 FR 4689, January 30, 1989. This section identifies the scope, design principles, minimum requirements, and a prescriptive compliance method for service water heating systems and equipment.

#### List of Subjects in 10 CFR Part 435

Architects, Building code officials, Buildings, Energy conservation, Energy conservation building performance standards, Engineers, Federal buildings and facilities, Housing water heaters, Insulation, Voluntary performance standards.

Issued in Washington, DC, April 1, 1994.

Christine A. Ervin,

Assistant Secretary, Energy Efficiency and Renewable Energy.

In consideration of the foregoing, part 435 of chapter II of title 10, Code of Federal Regulations, is amended as set forth below.

#### PART 435—ENERGY CONSERVATION VOLUNTARY PERFORMANCE STANDARDS FOR NEW BUILDINGS; MANDATORY FOR FEDERAL BUILDINGS

1. The authority citation for part 435 continues to read as follows:

Authority: 42 U.S.C. 6831-6870; 42 U.S.C. 8254; 42 U.S.C. 7101, et seq.

#### § 435.109 [Amended]

2. In § 435.109, Table 9.3-1 is revised and paragraph 9.3.2.1.1 is amended by removing the words "standby loss (SL) or", to read as follows:

TABLE 9.3-1.—STANDARD RATING CONDITIONS AND MINIMUM PERFORMANCE OF WATER HEATING EQUIPMENT  
[January 30, 1989]

Type	Fuel	Storage capacity (gal)	Input rating	Applicable test procedure	Minimum performance	
					DOE rating	Eff.
Storage water heaters.	Electric ...	<120 .....	<12 kW .....	DOE Test Procedures, 1985 Code of Federal Regulations Title 10, Part 430.	EF .....	
	.....	>120 (or)	>12 kW .....	ANSI C72.1-1972 .....	>0.95-0.00132V ...	
	Gas .....	<100 .....	<75,000 Btu/h .....	DOE Test Procedures, 1985 Code of Federal Regulations Title 10, Part 30.	EF .....	
					>0.62-0.0019V .....	

TABLE 9.3-1.—STANDARD RATING CONDITIONS AND MINIMUM PERFORMANCE OF WATER HEATING EQUIPMENT—  
Continued  
[January 30, 1989]

Type	Fuel	Storage capacity (gal)	Input rating	Applicable test procedure	Minimum performance	
					DOE rating	Eff.
	Oil	>100 (or) ..... <50 ..... ..... >50 (or) ..	>75,000 Btu/h ..... ..... <75,000 Btu/h ..... ..... <105,000 Btu/h ..... ..... >105,000 Btu/h .....	ANSI Z21.10.3-198 Gas Water Heaters w/Ad- denda Z21.10.3a-1985. DOE Test Procedures, 1985 Code of Federal Regulations Title 10, Part 430. ..... .....	..... EF ..... >0.59-0.0019V ..... >0.59-0.0019V .....	E <sub>t</sub> 77% ..... E <sub>c</sub> 83%

TABLE 9.3-1.—STANDARD RATING CONDITIONS AND MINIMUM PERFORMANCE OF WATER HEATING EQUIPMENT (CONT.)  
[January 30, 1989]

Class	Fuel	Type		Applicable test procedure	Minimum performance	
		Capacity	Input rating			
Unfired Storage .....	1 .....	All Volume ...	All Inputs .....	.....	.....	HL <6.5 Btu/h ft <sup>2</sup>
Instantaneous .....	Gas .....	.....	All Inputs .....	ANSI Z21.10.3-1984 .....	E <sub>t</sub> ..... 80% ...	
	Distill Oil .....	.....	All Inputs .....	.....	E <sub>c</sub> ..... 83% ...	
Pool Heaters .....	Gas/Oil .....	.....	All Inputs .....	ANSI Z21.56-1986 .....	E <sub>t</sub> ..... 78% ..	

Notes for Table 9.3-1:  
Terms Defined:

1. EF = Energy factor, overall heater efficiency by DOE Test Procedure E<sub>t</sub> = Thermal efficiency with 70°F, eT E<sub>c</sub> = Combustion efficiency, 100 percent—flue loss when smoke = 0 (trace is permitted) HL = Heat loss of tank surface area V = Storage volume in gallons

[FR Doc. 94-8748 Filed 4-15-94; 8:45 am]  
BILLING CODE 6450-01-P

**DEPARTMENT OF TRANSPORTATION**

**Federal Aviation Administration**

**14 CFR Part 39**

[Docket No. 93-NM-170-AD; Amendment 39-8876; AD 91-09-14 R1]

**Airworthiness Directives; Boeing Model 737-100, -200, and -200C Series Airplanes**

**AGENCY:** Federal Aviation Administration, DOT.

**ACTION:** Final rule.

**SUMMARY:** This amendment revises an existing airworthiness directive (AD), applicable to all Boeing Model 737-100, -200, and -200C series airplanes, that currently requires periodic inspections to detect missing nuts and/or damaged secondary support hardware adjacent to the engine aft mount, and replacement, if necessary. This amendment provides for the optional installation of a new,

modified support, which, if accomplished, constitutes terminating action for certain required inspections. This amendment is prompted by the development of a modification that will prevent wearing of the secondary support. The actions specified by this AD are intended to prevent failure of the secondary support to sustain engine loads in the event of failure of the aft engine mount cone bolt, which could result in the separation of the engine from the wing.

**DATES:** Effective May 18, 1994.

The incorporation by reference of certain publications listed in the regulations is approved by the Director of the Federal Register as of May 18, 1994.

**ADDRESSES:** The service information referenced in this AD may be obtained from Boeing Commercial Airplane Group, P.O. Box 3707, Seattle, Washington 98124-2207. This information may be examined at the Federal Aviation Administration (FAA), Transport Airplane Directorate, Rules Docket, 1601 Lind Avenue SW., Renton, Washington; or at the Office of the Federal Register, 800 North Capitol Street NW., suite 700, Washington, DC.

**FOR FURTHER INFORMATION CONTACT:** - Thomas Rodriguez, Aerospace Engineer, Airframe Branch, ANM-120S, FAA, Transport Airplane Directorate, Seattle Aircraft Certification Office (ACO), 1601 Lind Avenue SW., Renton, Washington 98055-4056; telephone (206) 227-2779; fax (206) 227-1181.

**SUPPLEMENTARY INFORMATION:** A proposal to amend part 39 of the Federal Aviation Regulations by revising AD 91-09-14, Amendment 39-6972 (56 FR 18696, April 24, 1991), which is applicable to all Boeing Model 737-100, -200, and -200C series airplanes, was published in the Federal Register on December 29, 1993 (58 FR 68787). Among other things, AD 91-09-14 currently requires periodic inspections to detect missing nuts and/or damaged secondary support hardware, and replacement, if necessary. The notice proposed to revise AD 91-09-14 to provide for the optional replacement of the existing aft engine mount secondary support with a new, modified secondary support. If accomplished, such replacement would constitute terminating action for certain of the currently required inspections.

Interested persons have been afforded an opportunity to participate in the making of this amendment. Due consideration has been given to the comments received.

All of the commenters support the proposal.

One commenter, Boeing, notes that the number of work hours necessary to accomplish the optional modification is closer to 60 work hours rather than 30 work hours, as was indicated in the cost impact information presented in the preamble to the notice. The FAA acknowledges this updated figure and has revised the cost impact information, below, to reflect it.

After careful review of the available data, including the comments noted above, the FAA has determined that air safety and the public interest require the adoption of the rule as proposed.

There are approximately 1,144 Model 737 series airplanes of the affected design in the worldwide fleet. The FAA estimates that 432 airplanes of U.S. registry will be affected by this AD.

The actions currently required by AD 91-09-14 take approximately 3 work hours per airplane to accomplish, at an average labor rate of \$55 per work hour. Based on these figures, the total cost impact of the currently required actions on U.S. operators is estimated to be \$71,280, or \$165 per airplane, per inspection cycle.

This revision of AD 91-09-14 adds no new additional costs to operators, since it merely provides for an optional installation that would provide terminating action for certain requirements. Should an operator elect to accomplish the installation, the associated actions will take approximately 60 work hours per airplane to accomplish, at an average labor rate of \$55 per work hour. Required parts will cost approximately \$6,818 per airplane. Based on these figures, the total cost of accomplishing the optional installation is estimated to be \$10,118 per airplane.

The regulations adopted herein will not have substantial direct effects on the States, on the relationship between the national government and the States, or on the distribution of power and responsibilities among the various levels of government. Therefore, in accordance with Executive Order 12612, it is determined that this final rule does not have sufficient federalism implications to warrant the preparation of a Federalism Assessment.

For the reasons discussed above, I certify that this action (1) is not a "significant regulatory action" under Executive Order 12866; (2) is not a "significant rule" under DOT

Regulatory Policies and Procedures (44 FR 11034, February 26, 1979); and (3) will not have a significant economic impact, positive or negative, on a substantial number of small entities under the criteria of the Regulatory Flexibility Act. A final evaluation has been prepared for this action and it is contained in the Rules Docket. A copy of it may be obtained from the Rules Docket at the location provided under the caption ADDRESSES.

#### List of Subjects in 14 CFR Part 39

Air transportation, Aircraft, Aviation safety, Incorporation by reference, Safety. Adoption of the Amendment.

Accordingly, pursuant to the authority delegated to me by the Administrator, the Federal Aviation Administration amends 14 CFR part 39 of the Federal Aviation Regulations as follows:

#### PART 39—AIRWORTHINESS DIRECTIVES

1. The authority citation for part 39 continues to read as follows:

**Authority:** 49 U.S.C. App. 1354(a), 1421 and 1423; 49 U.S.C. 106(g); and 14 CFR 11.89.

##### § 39.13 [Amended]

2. Section 39.13 is amended by removing amendment 39-6972 (56 FR 18696, April 24, 1991), and by adding a new airworthiness directive (AD), amendment 39-8876, to read as follows:

**91-09-14 R1 Boeing:** Amendment 39-8876. Docket 93-NM-170-AD. Revises AD 91-09-14, Amendment 39-6972.

**Applicability:** All Model 737-100, -200, and -200C series airplanes, certificated in any category.

**Compliance:** Required as indicated, unless accomplished previously.

To prevent failure of the secondary support to sustain engine loads, in the event of failure of the aft engine mount cone bolt, which could result in engine separation from the wing, accomplish the following:

(a) Within the next 45 landings after May 20, 1991 (the effective date of AD 91-09-14, amendment 39-6972), accomplish the following:

(1) Inspect the aft mount cone bolt indicator for proper alignment. Improper alignment indicates a broken aft cone bolt. Broken cone bolts must be replaced, prior to further flight, with bolts that have been inspected in accordance with Boeing Alert Service Bulletin 737-71A1212, dated December 22, 1987, using magnetic particle inspection techniques. Repeat the inspection of the indicator at intervals thereafter not to exceed 45 landings.

(2) Unless previously accomplished within the last 255 landings, inspect the aft mount cone bolt improved secondary support for missing nuts, evidence of bolt wear, and disbonded honeycomb core in accordance

with Boeing Service Bulletin 737-71-1250, dated June 14, 1990. Except as provided in paragraph (b) of this AD, missing nuts, bolts worn outside the limits specified in the service bulletin, or disbonded honeycomb core must be replaced, prior to further flight, with new or repaired identical parts. Repeat the inspection at intervals not to exceed 300 landings.

(b) Perform the following inspections if discrepant hardware is found during the inspections required by paragraph (a)(2) of this AD, and replacement hardware is not immediately available:

(1) Prior to further flight, and thereafter at intervals not to exceed 300 landings, inspect for cracks in the aft engine mount cone bolt, in accordance with Boeing Alert Service Bulletin 737-71A1212, dated December 22, 1987, using ultrasonic inspection techniques. Replace cracked cone bolts, prior to further flight, with bolts that have been inspected in accordance with the above service bulletin, using magnetic particle inspection techniques. Replacement (newly installed) cone bolts must be ultrasonically inspected for internal cracking in accordance with the provisions of this paragraph at intervals not to exceed 300 landings.

(2) At the next ultrasonic inspection, as required by paragraph (b)(1) of this AD, unless previously accomplished within 150 to 300 landings after cone bolt installation, accomplish a torque check to verify that the cone bolt is torqued to the proper torque limit specified in the appropriate Boeing maintenance manual. This check is to be accomplished without loosening the bolt. After every cone bolt installation, accomplish the torque check procedure required by this paragraph, between 150 landings and 300 landings following installation. Replacement of discrepant hardware in accordance with paragraph (a)(2) of this AD constitutes terminating action for the requirements of this paragraph.

(i) If the cone bolt torque is below one-half the specified torque, remove the cone bolt and replace it with a serviceable bolt.

(ii) If the cone bolt torque is equal to, or above one-half the specified torque, but below the specified torque, re-torque to the specified level and re-check the torque within the next 150 to 300 landings. If, at that time, the torque is below 90 percent of the specified torque, replace the cone bolt with a serviceable bolt.

(c) Replacement of the existing aft engine mount secondary support with a new, modified secondary support, Kit Number 65C37057-1, in accordance with Boeing Service Bulletin 737-71-1289, dated August 19, 1993, constitutes terminating action for the inspections required by paragraphs (a)(2), (b), (b)(1), and (b)(2) of this AD.

(d) An alternative method of compliance or adjustment of the compliance time that provides an acceptable level of safety may be used if approved by the Manager, Seattle Aircraft Certification Office (ACO), FAA, Transport Airplane Directorate. Operators shall submit their requests through an appropriate FAA Principal Maintenance Inspector, who may add comments and then send it to the Manager, Seattle ACO.

**Note 2:** Information concerning the existence of approved alternative methods of

compliance with this AD, if any, may be obtained from the Seattle ACO.

(e) Special flight permits may be issued in accordance with Federal Aviation Regulations (FAR) 21.197 and 21.199 to operate the airplane to a location where the requirements of this AD can be accomplished.

(f) The optional replacement shall be done in accordance with Boeing Service Bulletin 737-71-1289, dated August 19, 1993. This incorporation by reference was approved by the Director of the Federal Register in accordance with 5 U.S.C. 552(a) and 1 CFR Part 51. Copies may be obtained from Boeing Commercial Airplane Group, P.O. Box 3707, Seattle, Washington 98124-2207. Copies may be inspected at the FAA, Transport Airplane Directorate, 1601 Lind Avenue SW., Renton, Washington; or at the Office of the Federal Register, 800 North Capitol Street NW., suite 700, Washington, DC.

(g) This amendment becomes effective on May 18, 1994.

Issued in Renton, Washington, on April 4, 1994.

Darrell M. Pederson,

Acting Manager, Transport Airplane Directorate, Aircraft Certification Service.

[FR Doc. 94-8418 Filed 4-15-94; 8:45 am]

BILLING CODE 4910-13-U

#### 14 CFR Part 71

[Airspace Docket No. 93-AGL-13]

#### Alteration of Jet Route J-34

AGENCY: Federal Aviation Administration (FAA), DOT.  
ACTION: Final rule.

**SUMMARY:** This action changes the description of Jet Route J-34 located between the Badger, WI, Very High Frequency Omnidirectional Range/Tactical Air Navigation (VORTAC) facility, the Grand Rapids, MI, Very High Frequency Omnidirectional Range/Distance Measuring Equipment (VOR/DME) facility, and the Carleton, MI, VORTAC. This change removes the reference to the radials from the navigational aids (NAVAIDS), and designates the Grand Rapids, MI, (GRR) VOR/DME as the turning point for aircraft transiting from the Badger, WI, (BAE) VORTAC to the Carleton, MI, (CRL) VORTAC.

**EFFECTIVE DATE:** 0901 U.T.C., June 23, 1994.

**FOR FURTHER INFORMATION CONTACT:** Patricia P. Crawford, Airspace and Obstruction Evaluation Branch (ATP-240), Airspace-Rules and Aeronautical Information Division, Air Traffic Rules and Procedures Service, Federal Aviation Administration, 800 Independence Avenue, SW., Washington, DC 20591; telephone: (202) 267-9255.

#### SUPPLEMENTARY INFORMATION:

##### History

On September 15, 1993, the FAA proposed to amend part 71 of the Federal Aviation Regulations (14 CFR part 71) to alter the description of Jet Route J-34 (58 FR 48331). Interested parties were invited to participate in this rulemaking proceeding by submitting written comments on the proposal to the FAA. No comments objecting to the proposal were received. Except for editorial changes, this amendment is the same as that proposed in the notice. Jet routes are published in paragraph 2004 of FAA Order 7400.9A dated June 17, 1993, and effective September 16, 1993, which is incorporated by reference in 14 CFR 71.1 (58 FR 36298; July 6, 1993). The jet route listed in this document will be published subsequently in the Order.

##### The Rule

This amendment to part 71 of the Federal Aviation Regulations amends the description of Jet Route J-34 by removing the reference to the radials from the NAVAIDS and designates the Grand Rapids, MI, (GRR) VOR/DME as the turning point for aircraft transiting from the Badger, WI, (BAE) VORTAC to the Carleton, MI, (CRL) VORTAC.

The FAA has determined that this regulation only involves an established body of technical regulations for which frequent and routine amendments are necessary to keep them operationally current. It, therefore—(1) is not a "significant regulatory action" under Executive Order 12866; (2) is not a "significant rule" under DOT Regulatory Policies and Procedures (44 FR 11034; February 26, 1979); and (3) does not warrant preparation of a regulatory evaluation as the anticipated impact is so minimal. Since this is a routine matter that will only affect air traffic procedures and air navigation, it is certified that this rule will not have a significant economic impact on a substantial number of small entities under the criteria of the Regulatory Flexibility Act.

##### List of Subjects in 14 CFR Part 71

Airspace, Incorporation by reference, Navigation (air).

##### Adoption of the Amendment

In consideration of the foregoing, the Federal Aviation Administration amends 14 CFR part 71 as follows:

##### PART 71—[AMENDED]

1. The authority citation for part 71 continues to read as follows:

Authority: 49 U.S.C. app. 1348(a), 1354(a), 1510; E.O. 10854, 24 FR 9565, 3 CFR, 1959-1963 Comp., p. 389; 49 U.S.C. 106(g); 14 CFR 11.69.

##### § 71.1 [Amended]

2. The incorporation by reference in 14 CFR 71.1 of the Federal Aviation Administration Order 7400.9A, Airspace Designations and Reporting Points, dated June 17, 1993, and effective September 16, 1993, is amended as follows:

Paragraph 2004—Jet Routes

\* \* \* \* \*

##### J-34 [Revised]

From Hoquiam, WA, via Olympia, WA; Moses Lake, WA; Helena, MT; Billings, MT; Dupree, SD; Redwood Falls, MN; Nodine, MN; Dells, WI; Badger, WI; Grand Rapids, MI; Carleton, MI; DRYER, OH; Bellaire, OH; INT Bellaire 133° and Kessel, WV, 276° radials; Kessel; to INT Kessel 097° and Armel, VA, 292° radials.

\* \* \* \* \*

Issued in Washington, DC, on April 7, 1994.

Harold W. Becker,

Manager, Airspace-Rules and Aeronautical Information Division.

[FR Doc. 94-9220 Filed 4-15-94; 8:45 am]

BILLING CODE 4910-13-M

#### DEPARTMENT OF HEALTH AND HUMAN SERVICES

#### Food and Drug Administration

#### 21 CFR Part 558

#### New Animal Drugs for Use in Animal Feeds; Laidlomycin Propionate Potassium

AGENCY: Food and Drug Administration, HHS.

ACTION: Final rule.

**SUMMARY:** The Food and Drug Administration (FDA) is amending the animal drug regulations to reflect the approval of a new animal drug application (NADA) filed by Syntex Animal Health, Division of Syntex Agribusiness, Inc. The NADA provides for the use of laidlomycin propionate potassium (CATTLYST®) Type A medicated article to make Type B and Type C medicated feeds for improved feed efficiency and increased rate of weight gain in cattle fed in confinement for slaughter.

**EFFECTIVE DATE:** April 18, 1994.

**FOR FURTHER INFORMATION CONTACT:** Daniel A. Benz, Center for Veterinary Medicine (HFV-126), Food and Drug Administration, 7500 Standish Pl., Rockville, MD 20855, 301-594-1638.



**SUPPLEMENTARY INFORMATION:** Syntex Animal Health, Division of Syntex Agribusiness, Inc., 3401 Hillview Ave., Palo Alto, CA 94304, filed NADA 141-025 which provides for the use of 50 grams (g) per pound of laidlomycin propionate potassium (CATTLYST®) Type A medicated article to make Type B and Type C medicated feeds for improved feed efficiency and increased rate of weight gain in cattle fed in confinement for slaughter. The Type C feed contains 5 g of laidlomycin propionate potassium per ton of feed to provide not less than 30 milligrams (mg) and not more than 75 mg per head per day for improved feed efficiency and increased rate of weight gain, and 5 to 10 g of laidlomycin propionate potassium per ton of feed to provide not less than 30 mg and not more than 150 mg per head per day for improved feed efficiency.

The NADA is approved as of March 4, 1994, and the regulations are amended in part 558 (21 CFR part 558) by adding laidlomycin propionate potassium to the Category I table in § 558.4(d) and by adding new § 558.305 to reflect the approval. The basis for approval is discussed in the freedom of information summary.

In accordance with the freedom of information provisions of part 20 (21 CFR part 20) and § 514.11(e)(2)(ii) (21 CFR 514.11(e)(2)(ii)), a summary of safety and effectiveness data and information submitted to support approval of this application may be seen in the Dockets Management Branch (HFA-305), Food and Drug Administration, rm. 1-23, 12420 Parklawn Dr., Rockville, MD 20857, between 9 a.m. and 4 p.m., Monday through Friday.

Section 512(c)(2)(F)(i) of the Federal Food, Drug, and Cosmetic Act (the act) (21 U.S.C. 360b(c)(2)(F)(i) provides a 5-year period of exclusivity to this original NADA beginning March 4, 1994, because no active ingredient (including any ester or salt of the active ingredient) has been approved in any other application under section 512(b)(1) of the act.

The agency has carefully considered the potential environmental effects of this action. FDA has concluded that the action will not have a significant impact on the human environment, and that an environmental impact statement is not required. The agency's finding of no significant impact and the evidence supporting that finding, contained in an

environmental assessment, may be seen in the Dockets Management Branch (address above) between 9 a.m. and 4 p.m., Monday through Friday.

**List of Subjects 21 CFR Part 558**

Animal drugs, Animal feeds. Therefore, under the Federal Food, Drug, and Cosmetic Act and under authority delegated to the Commissioner of Food and Drugs and redelegated to the Center for Veterinary Medicine, 21 CFR part 558 is amended as follows:

**PART 558—NEW ANIMAL DRUGS FOR USE IN ANIMAL FEEDS**

1. The authority citation for 21 CFR part 558 continues to read as follows:

**Authority:** Secs. 512, 701 of the Federal Food, Drug, and Cosmetic Act (21 U.S.C. 360b, 371).

2. Section 558.4 is amended in paragraph (d) in the "Category I" table by alphabetically adding a new entry for "Laidlomycin propionate potassium" to read as follows:

**§ 558.4 Medicated feed applications.**

```
* * * * *
(d) * * *
* * * * *
```

**CATEGORY I**

Drug	Assay limits percent <sup>1</sup> type A	Type B maximum (200x)	Assay limits percent <sup>1</sup> type B/C <sup>2</sup>
Laidlomycin propionate potassium .....	90-110	1 g/pound (0.22%) .....	90-115/85-115

<sup>1</sup> Percent of labeled amount.

<sup>2</sup> Values given represent ranges for either Type B or Type C medicated feeds. For those drugs that have two range limits, the first set is for a Type B medicated feed and the second set is for a Type C medicated feed. These values (ranges) have been assigned in order to provide for the possibility of dilution of a Type B medicated feed with lower assay limits to make Type C medicated feed.

\* \* \* \* \*  
3. New § 558.305 is added to subpart B to read as follows:

**§ 558.305 Laidlomycin propionate potassium.**

(a) *Approvals.* Type A medicated articles: 50 grams per pound to 000033 in § 510.600(c) of this chapter.

(b) *Conditions of use.* Used in cattle feed as follows:

(1) *Amount.* Laidlomycin propionate potassium, 5 grams per ton.

(i) *Indications for use.* For improved feed efficiency and increased rate of weight gain.

(ii) *Limitations.* Feed only to cattle being fed in confinement for slaughter. Feed continuously in a Type C feed at

a rate of 30 to 75 milligrams per head per day.

(2) *Amount.* Laidlomycin propionate potassium, 5 to 10 grams per ton.

(i) *Indications for use.* For improved feed efficiency.

(ii) *Limitations.* Feed only to cattle being fed in confinement for slaughter. Feed continuously in a Type C feed at a rate of 30 to 150 milligrams per head per day.

(3) *Special considerations*—(i) Do not allow horses or other equines access to feeds containing laidlomycin propionate potassium.

(ii) The safety of laidlomycin propionate potassium in unapproved species has not been established.

(iii) Not for use in animals intended for breeding.

Dated: April 8, 1994.

**Richard H. Teske,**  
*Acting Director, Center for Veterinary Medicine.*

[FR Doc. 94-9189 Filed 4-15-94; 8:45 am]

BILLING CODE 4160-01-F

**DEPARTMENT OF TRANSPORTATION****Coast Guard****33 CFR Part 117**

[CGD09-93-036]

**Drawbridge Operation Regulations; Chicago River, IL**

AGENCY: Coast Guard, DOT.

ACTION: Final rule.

**SUMMARY:** The Coast Guard is changing the operating regulations governing bridges over the Chicago River System which are owned and operated by the City of Chicago. This final rule expands the periods of time when Chicago's highway bridges need not open for the passage of recreational vessels, establishes a specific number of recreational vessels that will be required to gather in order for the bridges to open, and requires recreational vessel owner/operators or their representatives to give notice in advance of a vessel's time of intended passage through the draws. Additionally, the period of time during the winter months when the bridges need open only after receiving an advance notice is expanded. This final rule also adds a Wednesday opening for the passage of recreational vessels during the Spring break-out period (April 15-June 15). This final rule also adds the Madison Street bridge to the bridge list for the South Branch. The Madison Street Bridge was inadvertently left out of the Notice of Proposed Rulemaking. This action will accommodate the needs of vehicle traffic while providing for the reasonable needs of navigation.

**EFFECTIVE DATE:** This rule is effective on April 18, 1994.

**ADDRESSES:** Unless otherwise indicated, documents referenced in this preamble are available for inspection and copying at the office of the Commander (obr), Ninth Coast Guard District, 1240 East Ninth Street, Cleveland, Ohio 44199-2060, between 6:30 a.m. and 3 p.m., Monday through Friday, except Federal holidays. The telephone number is (216) 522-3993 for information.

**FOR FURTHER INFORMATION CONTACT:** Mr. Robert W. Bloom, Jr., Bridge Program Manager, Ninth Coast Guard District, (212) 522-3993.

**SUPPLEMENTARY INFORMATION:****Drafting Information**

The principal persons involved in drafting this document are Mr. Robert W. Bloom, Jr., Project Manager, and Commander J.M. Collin, Project Counsel.

**Regulatory History**

On May 12, 1993, the Coast Guard published 58 FR 27933, a deviation from the permanent rule to allow the City of Chicago to reduce the periods during which the draws must be opened for recreational vessels, to require advance notice for opening and to require the recreational vessels to be organized in flotillas of five to twenty-five vessels for passage. Subsequent deviations were published on June 16 (58 FR 33191), August 12 (58 FR 42856), October 21 (58 FR 54289) and November 29 (58 FR 62532).

On Wednesday, December 22, 1993, the Coast Guard published a notice of proposed rulemaking and notice of public hearing entitled Drawbridge Operation Regulations: Chicago River, IL. (58 FR 67745). The comment period ended February 7, 1994. The Commander, Ninth Coast Guard District, also published the proposed regulation change as a Public Notice on December 17, 1993, with a comment period ending January 22, 1994. The Coast Guard received 132 letters commenting on the proposal. Additionally, the Commander, Ninth Coast Guard District held a public hearing on January 20, 1994, in Chicago, Illinois. There were 107 persons in attendance at the public hearing, of whom 32 made oral statements and/or furnished data on the proposed regulations.

**Background and Purpose**

Presently, the bridges owned and operated by the City of Chicago are governed in accordance with 33 CFR 117.391 which allows draws to remain closed through the peak vehicle traffic periods during the morning and afternoon rush hours. In addition, certain bridges need not open for the passage of vessels unless notice is given in advance of a vessel's intended time of passage through the draws. The City of Chicago has requested that, from April 1 through November 30, the bridges which cross the Chicago River and the Chicago River Branches not be required to open for the passage of recreational vessels except between the hours of 6:30 p.m. and 12 midnight on Tuesdays and Thursdays, and between the hours of 7 a.m. and 7 p.m. on Saturdays and Sundays. During these times, the bridges would not be required to open unless there are no fewer than five recreational vessels and not more than twenty-five recreational vessels available to transit during the opening and these vessels have given at least twenty-four hours advance notice of their requested time of passage through the draws. From December 1 through

March 31, the draws of the highway bridges across the Chicago River, the North Branch of the Chicago River, North Branch Canal, and the South Branch of the Chicago River shall open on signal for all vessels if notice is given at least 12 hours in advance of a vessel's time of intended passage through the draws. On December 22, 1993, the Coast Guard issued a Notice of Proposed Rulemaking to change the permanent operating schedules for the Chicago River bridges. This NPRM contained no weekday daytime openings, but did provide a 12-hour opening period on Saturdays and Sundays, as well as a 6:30 p.m. to midnight opening period on Tuesdays and Thursdays.

**Discussion of Comments and Changes**

From the 132 comments received from the Public Notice, 35 commenters were in support of limiting the openings of the Chicago bridges for recreational vessels, and 97 were opposed to limiting the openings of bridges for recreational vessels. The comments in support of the proposal were from managers of businesses, building managers and officials from various Departments of the City of Chicago. Reasons for support of the proposed regulations change submitted were: A proposal to build a Chicago Central Area Circulator, a light rail system, that will be used to transport people within the Chicago Loop; disruption of vehicle and pedestrian traffic when bridges open for the passage of vessels during the day; the movement of emergency vehicles (fire, ambulance, police) that could allow response time when a bridge is open for the passage of vessels; the cost of manpower to open the bridges; additional air pollution caused while vehicles are stopped during bridge openings; and the disruption of deliveries made to and from various business interests within the loop during business hours.

The comments opposing the proposed bridge operating regulations were concerned with unsafe conditions because the two weekday openings begin when there are but a few hours of daylight left. Boaters do not reach Lake Michigan and do not reach their respective marinas along the Lake Michigan Coast until late at night or early morning hours when there is total darkness. In addition, these comments are concerned with unsafe conditions associated with the mass of vessels that are required to gather in order to have the bridge open. The large number of vessels during periods of darkness has caused some minor accidents among boaters on previous trips and they feel, should a serious accident occur, or

someone fall overboard, the night trips would cause a loss of life because it is more difficult to locate a person in the water and conduct rescue operations when it is dark. Other comments received in opposition of the proposed regulations showed concerns with the inability of bridgetenders to see when all vessels have cleared the bridge, the loss of accessibility to the boatyards for normal and emergency vessel repairs, floating debris, unsafe seawalls and submerged pilings in the water that are not visible during periods of darkness, the additional cost, and the availability of professional help when a vessel needs towing or is in need of emergency repairs during late evening or early morning hours.

Commenters were also opposed to the proposal stating the inability of the City of Chicago, and the lack of personnel available, to move the mass of boaters in or out of the Chicago River System in a timely manner. Many of the commenters requested that the Coast Guard, when considering a final regulation, protect their right to navigate on a federally controlled waterway in a safe and timely manner, and develop a regulation that meets the interests of all parties, both land and waterborne traffic.

From the comments and data received in support of not opening the City of Chicago bridges for the passage of recreational vessels on weekdays during the day, the proposed Central Area Circulator was a point considered for not opening the bridges during this period of time. However, this light rail system is still in the planning and funding stages and, at this point in time, daytime bridge openings will have no effect on a transportation system not yet in place.

Of the 32 oral statements and data submitted at the Public Hearing, 8 were in support of limiting the openings of the Chicago bridges for recreational vessels, and 23 were opposed to limiting the openings of bridges for recreational vessels.

After a review of the comments, the Coast Guard, to maintain safety on a navigable water of the United States, and to protect the economic benefit of the river infrastructure, has added a Wednesday daytime opening period (11 a.m.-2 p.m.), 117.391(b)(1) during the Spring Breakout (April 15 through June 15). The Wednesday daytime opening will give recreational boaters the opportunity to transit through the Chicago River System during daylight during the week. Also, the Wednesday daytime opening will give the mariner the alternative to transit the river during the week if a scheduled daytime trip on Saturday or Sunday is delayed or

postponed due to a special event bridge closure, bridge failure, or bad weather.

One of the primary concerns of this rulemaking is the regulation on the draws during the Spring Breakout period, from April 15 through June 15. The Coast Guard has determined that delay in implementing this rule would be contrary to the public interest, and that good cause exists to make this rule effective in fewer than 30 days after publication in the *Federal Register*. In order that the new regulations be fully implemented during the 1994 Spring Breakout, this rule is being made effective on April 18, 1994.

#### Regulatory Evaluation

This rule is not major under Executive Order 12886 and not significant under the Department of Transportation Regulatory Policies and Procedures (44 FR 11040; February 26, 1979). The Coast Guard expects the economic impact of this rule to be so minimal that a Regulatory Evaluation is unnecessary. This change to the operating regulations for bridges over the Chicago River System allows recreational vessels to navigate the Chicago River System during the times specified by these regulations, after having given an advance notice to the City of Chicago.

#### Small Entities

This rule will provide boaters with adequate windows of time to transit to and from their respective boatyards while providing the City of Chicago with relief during times when there is more than normal activity in the City. Therefore, the Coast Guard certifies under 605(b) of the Regulatory Flexibility Act (5 U.S.C. 601 *et seq.*) that this proposal will not have a significant economic impact on a substantial number of small entities.

#### Collection of Information

This proposal contains no collection of information requirements under the Paperwork Reduction Act (44 U.S.C. 3501 *et seq.*).

#### Federalism

The Coast Guard has analyzed this final rule under the principles and criteria contained in Executive Order 12612 and has determined that this rule does not have sufficient federalism implications to warrant the preparation of a Federalism Assessment.

#### Environment

The Coast Guard considered the environmental impact of this rule and concluded that, under section 2.B.2.g.5 of Commandant Instruction M16475.1B, this rule is categorically excluded from

further environmental documentation. A Categorical Exclusion Determination statement has been prepared and placed in the docket.

#### List of Subjects in 33 CFR Part 117

##### Bridges.

For reasons set out in the preamble, the Coast Guard amends 33 CFR 117 as follows:

#### PART 117—DRAWBRIDGE OPERATION REGULATIONS

1. The authority citation for part 117 continues to read as follows:

**Authority:** 33 U.S.C. 499; 49 CFR 1.46; 33 CFR 1.05-1(g).

2. Section 117.391 is revised to read as follows:

##### § 117.391 Chicago River.

The draws of bridges operated by the City of Chicago shall operate as follows:

- (a) For commercial vessels:
  - (1) From April 1 through November 30—
    - (i) The draws of the bridges across the Chicago River from its mouth to the junction of the North and South Branches, across the South Branch from the junction to and including the West Roosevelt Road, and across the North Branch to and including North Kinzie Street and the Ohio Street bridge shall open on signal; except that, from Monday through Friday from 7:30 a.m. to 10 a.m., and 4 p.m. to 6:30 p.m., the draws need not be opened for the passage of vessels.
    - (ii) The draws of the bridges across the North Branch of the Chicago River at Grand Avenue, the bridges across the North Branch of the Chicago River north of the Ohio Street bridge to and including North Halsted Street, and bridges across the South Branch of the Chicago River above South Halsted Street to and including West Roosevelt Road, shall open on signal; except that, from Monday through Friday from 7 a.m. to 8 a.m. and 5:30 p.m. to 6:30 p.m., the draws need not open for the passage of vessels.
    - (iii) The draws of the bridges across the North Branch of the Chicago River north of North Halsted Street and the South Branch of the Chicago River south of South Halsted Street shall open on signal; except that, from 7 a.m. to 8 a.m. and 5:30 p.m. to 6:30 p.m. the draws need not be opened for the passage of vessels.
    - (iv) The draws of the Randolph Street, Cermak Road, Throop Street, and Loomis Street bridges across the South Branch of the Chicago River, the North Halsted Street bridge across the North Branch Canal, and the West Kinzie

Street bridge across the North Branch of the Chicago River shall open on signal.

(v) The draws of the following bridges in Chicago shall open on signal if tended or within 30 minutes after notice is given to the City of Chicago Bridge Desk:

*South Branch*

Washington Street  
Madison Street  
Monroe Street  
Adams Street  
Jackson Boulevard  
Van Buren Street  
Congress Street (Eisenhower Expressway)  
Harrison Street  
Roosevelt Road  
Eighteenth Street  
Canal Street  
South Halsted Street

*West Fork of the South Branch*

South Ashland Avenue  
South Damen Avenue

*Chicago River, North Branch*

Grand Avenue  
Chicago Avenue  
North Halsted Street  
Ogden Avenue  
Division Street

*North Branch Canal*

Ogden Avenue  
Division Street

(vi) The draws of bridges across the North Branch Canal that have a vertical Clearance of less than 17 feet above Low Water Datum for Lake Michigan shall open at any time to permit the passage of tugs and barges.

(2) From December 1 through March 31, the draws of the highway bridges across the Chicago River, the North Branch of the Chicago River, North Branch Canal, and the South Branch of the Chicago River shall open on signal if at least 12 hours notice is given. However, the bridges need not open during those periods of time specified in (a)(1)(i), (ii) and (iii) of this section.

(b) For recreational vessels, the draws of the City of Chicago owned bridges shall operate as follows:

*Main Branch*

Lake Shore Drive  
Columbus Drive  
Michigan Avenue  
Wabash Avenue  
State Street  
Dearborn Street  
Clark Street  
LaSalle Street  
Wells Street  
Franklin-Orleans Street

*South Branch*

Lake Street  
Randolph Street  
Washington Street  
Monroe Street  
Madison Street

Adams Street  
Jackson Boulevard  
Van Buren Street  
Eisenhower Expressway  
Harrison Street  
Roosevelt Road  
18th Street  
Canal Street  
South Halsted Street  
South Loomis Street  
South Ashland Avenue

*North Branch*

Grand Avenue  
Ohio Street  
Chicago Avenue  
N Halsted Street

(1) From April 1 through November 30—

(i) The draws need to open only between the hours of 6:30 p.m. and 12 midnight on Tuesdays and Thursdays.

(ii) The draws need to open only between the hours of 7 a.m. and 7 p.m. on Saturdays and on Sundays.

(iii) From April 15 through June 15, the draws need to open on Wednesdays, only from 11 a.m. to 2 p.m.

(iv) The draws need to open only after notice has been given at least 24 hours in advance of their requested time of passage and only during the periods of times specified in (b)(1) (i), (ii), (iii) and (iv) of this section when no fewer than five vessels and not more than 25 vessels are available to transit through the draws during one scheduled opening. However, when circumstances preclude being able to assemble the minimum number of vessels, requests shall be made to the Chicago Bridge Desk to establish a scheduled time for bridge openings. Circumstances include vessels returning for repair and vessels in distress.

(2) From December 1 through March 31, the draws of the highway bridges across the Chicago River, the North Branch of the Chicago River, North Branch Canal, and the South Branch of the Chicago River shall open on signal if at least 12 hours notice is given.

(c) The draws on the Lake Shore Drive bridge across Ogden Slip need not be opened for the passage of vessels.

(d) The draws of the North Avenue, Cortland Street, Webster Avenue, North Ashland Avenue, Chicago and Northwestern railroad, North Damen Avenue, and Belmont Avenue bridges across the North Branch of the Chicago River need not open for the passage of vessels.

(e) The draw of the Chicago, Milwaukee, St. Paul and Pacific railroad bridge across the North Branch Canal need not open for the passage of vessels.

(f) The opening signal for all Chicago River bridges is three short blasts or by shouting; except that, four short blasts is

the opening signal for the Chicago and Northwestern railroad bridge near West Kinzie Street and the Milwaukee Road bridge near West North Avenue and five short blasts is the opening signal for the Lake Shore Bridge when approaching from the north.

Dated: April 13, 1994.

Rudy K. Peschel,

Rear Admiral, U.S. Coast Guard, Commander, Ninth Coast Guard District.

[FR Doc. 94-9408 Filed 4-14-94; 1:46 pm]

BILLING CODE 4910-14-M

**DEPARTMENT OF COMMERCE**

**Patent and Trademark Office**

**37 CFR Part 1**

**Duty of Disclosure**

*CFR Correction*

In title 37 of the Code of Federal Regulations, revised as of July 1, 1993, on page 63, in § 1.175, paragraph (b) was inadvertently removed. As reinstated, the text of paragraph (b) reads as follows:

**§ 1.175 Reissue oath or declaration.**

(b) Corroborating affidavits or declarations of others may be filed and the examiner may, in any case, require additional information or affidavits or declarations concerning the application for reissue and its object.

BILLING CODE 1505-01-D

**ENVIRONMENTAL PROTECTION AGENCY**

**40 CFR Parts 52 and 81**

[NC58-2-6082; FRL-4856-1]

**Approval and Promulgation of Implementation Plans and Designation of Areas for Air Quality Planning Purposes; State of North Carolina**

AGENCY: Environmental Protection Agency (EPA).

ACTION: Final rule.

**SUMMARY:** On November 13, 1992, the State of North Carolina, through the North Carolina Department of Environment, Health, and Natural Resources (NCDEHNR), submitted a maintenance plan and a request to redesignate the Raleigh/Durham area (classified as a moderate nonattainment area) from nonattainment to attainment for ozone (O<sub>3</sub>). The O<sub>3</sub> nonattainment

area includes the following counties: Durham, Wake, and the Dutchville Township portion of Granville. Under the Clean Air Act, designations can be changed if sufficient data are available to warrant such changes. In this action, EPA is approving the State of North Carolina's submittal because it meets the maintenance plan and redesignation requirements. The approved maintenance plan will become a federally enforceable part of the SIP for the Raleigh/Durham area.

On January 15, 1993, in a letter from Patrick Tobin to Governor James Hunt, the EPA notified the State of North Carolina that the EPA had made a finding of failure to submit required programs for the nonattainment area. EPA's redesignation of the Raleigh/Durham area to attainment abrogates those requirements for this area. Therefore, the sanctions and federal implementation plan clocks begun by those findings are stopped at the time of the redesignation.

**EFFECTIVE DATE:** This final rule will be effective June 17, 1994, unless notice is received by May 18, 1994, that someone wishes to submit adverse or critical comments. If the effective date is delayed, timely notice will be published in the Federal Register.

**ADDRESSES:** Written comments should be sent to Bill Eckert at the EPA address in Atlanta, Georgia listed below. Copies of the redesignation request and the State of North Carolina's submittal are available for public review during normal business hours at the addresses listed below. EPA's technical support document (TSD) is available for public review during normal business hours at the EPA addresses listed below.

Air and Radiation Docket and Information Center (Air Docket 6102), U.S. Environmental Protection Agency, 401 M Street SW., Washington, DC 20460

Environmental Protection Agency, Region IV, Air Programs Branch, 345 Courtland Street NE., Atlanta, GA 30365

North Carolina Department of Environment, Health, and Natural Resources, Division of Environmental Management, 512 North Salisbury Street, Raleigh, NC 27604

**FOR FURTHER INFORMATION CONTACT:** Bill Eckert of the EPA Region IV Air Programs Branch at (404) 347-2864 and at the Region IV address.

**SUPPLEMENTARY INFORMATION:** On November 15, 1990, the Clean Air Act Amendments of 1990 (CAA) were enacted. (Pub. L. 101-549, 104 Stat. 2399, codified at 42 U.S.C. 7401-7671q.) Under section 107(d)(1), in conjunction

with the Governor of North Carolina, EPA designated the Raleigh/Durham area as nonattainment because the area violated the O<sub>3</sub> standard during the period from 1987 through 1989. Furthermore, upon designation, the Raleigh/Durham area was classified as moderate under section 181(a)(1). (See 56 FR 56694 (November 6, 1991) and 57 FR 56762 (November 30, 1992), codified at 40 CFR 81.334.)

The Raleigh/Durham area more recently has ambient monitoring data that show no violations of the O<sub>3</sub> National Ambient Air Quality Standards (NAAQS), during the period from 1989 through 1992. Therefore, in an effort to comply with the CAA and to ensure continued attainment of the NAAQS, on November 13, 1992, the State of North Carolina submitted for parallel processing an O<sub>3</sub> maintenance SIP for the Raleigh/Durham area and requested redesignation of the area to attainment with respect to the O<sub>3</sub> NAAQS. On January 13, 1993, the NCDEHNR submitted evidence that a public hearing was held on the maintenance plan and on July 8, 1993, the maintenance plan became State effective. In addition, there have been no violations reported for the 1993 O<sub>3</sub> season.

On August 11, 1993, Region IV determined that the information received from the NCDEHNR constituted a complete redesignation request under the general completeness criteria of 40 CFR part 51, appendix V, sections 2.1 and 2.2. However, for purposes of determining what requirements are applicable for redesignation purposes, EPA believes it is necessary to identify when NCDEHNR first submitted a redesignation request that meets the completeness criteria. EPA noted in a previous policy memorandum that parallel processing requests for submittals under the CAA, including redesignation submittals, would not be determined complete. See the memorandum entitled "State Implementation Plan (SIP) Actions Submitted in Response to Clean Air Act (Act) Deadlines" from John Calcagni to Air Programs Division Directors, Regions I-X, dated October 28, 1992 (Memorandum). The rationale for this conclusion was that the parallel processing exception to the completeness criteria (40 CFR part 51, appendix V, section 2.3) was not intended to extend statutory due dates for mandatory submittals. (See Memorandum at 3-4.) However, since requests for redesignation are not mandatory submittals under the CAA, EPA believes that it must change its policy with respect to redesignation

submittals to conform to the existing completeness criteria. Therefore, EPA believes, the parallel processing exception to the completeness criteria may be applied to redesignation request submittals, at least until such time as the EPA decides to revise that exception. NCDEHNR submitted a redesignation request on November 13, 1992. In the November 13 submittal, NCDEHNR submitted the maintenance plan, thereby including the final element to make the November 13, 1992, request for parallel processing complete under the parallel processing exception to the completeness criteria. When the maintenance plan became state effective on July 8, 1993, the State of North Carolina no longer needed parallel processing for the redesignation request and maintenance plan. Therefore, the EPA informed the State of North Carolina on August 11, 1993, that the redesignation request and maintenance plan submittals were complete under the general completeness criteria.

The North Carolina redesignation request for the Raleigh/Durham area meets the five requirements of section 107(d)(3)(E) for redesignation to attainment. The following is a brief description of how the State of North Carolina has fulfilled each of these requirements. Because the maintenance plan is a critical element of the redesignation request, EPA will discuss its evaluation of the maintenance plan under its analysis of the redesignation request.

#### 1. The Area Must Have Attained the O<sub>3</sub> NAAQS

The State of North Carolina's request is based on an analysis of quality assured ambient air quality monitoring data which is relevant to the maintenance plan and to the redesignation request. Most recent ambient air quality monitoring data for calendar year 1989 through calendar year 1992 show an expected exceedence rate of less than 1.0 per year of the O<sub>3</sub> NAAQS in the Raleigh/Durham area. (See 40 CFR 50.9 and appendix H.) Because the Raleigh/Durham area has complete quality-assured data showing no violations of the standard over the most recent consecutive three calendar year period, the Raleigh/Durham area has met the first statutory criterion of attainment of the O<sub>3</sub> NAAQS. In addition, there were no violations reported for the 1993 O<sub>3</sub> season. The State of North Carolina has committed to continue monitoring in this area in accordance with 40 CFR part 58.

## 2. The Area Has Met All Applicable Requirements Under Section 110 and Part D of the Act

On April 17, 1980, and on September 10, 1980, EPA fully approved North Carolina's SIP as meeting the requirements of section 110(a)(2) and part D of the 1977 CAA (45 FR 26038 and 45 FR 59578). The amended CAA, however, revised section 110(a)(2) and, under part D, revised section 172 and added new requirements for all nonattainment areas. Therefore, for purposes of redesignation, to meet the requirement that the SIP contain all applicable requirements under the CAA, EPA reviewed the North Carolina SIP to ensure that it contained all measures due under the amended CAA prior to or at the time the State of North Carolina submitted its redesignation request.

### A. Section 110 Requirements

Although section 110 was amended, the Raleigh/Durham area SIP meets the requirements of amended section 110(a)(2). A number of the requirements did not change in substance and, therefore, EPA believes that the pre-amendment SIP met these requirements. As to those requirements that were amended, see 57 FR 27936 and 57 FR 27939 (June 23, 1992), many are duplicative of other requirements of the CAA. EPA has analyzed the SIP and determined that it is consistent with the requirements of amended section 110(a)(2).

### B. Part D Requirements

Before the Raleigh/Durham area may be redesignated to attainment, it also must have fulfilled the applicable requirements of part D. Under part D, an area's classification indicates the requirements to which it will be subject. Subpart 1 of part D sets forth the basic nonattainment requirements applicable to all nonattainment areas, classified as well as nonclassifiable. Subpart 2 of part D establishes additional requirements for O<sub>3</sub> nonattainment areas classified under table 1 of section 181(a). The Raleigh/Durham area is classified as moderate (See 56 FR 56694, codified at 40 CFR 81.334). The State of North Carolina submitted their request for redesignation of the Raleigh/Durham area prior to November 15, 1992. Therefore, in order to be redesignated to attainment, the State of North Carolina must meet the applicable requirements of subpart 1 of part D, specifically sections 172(c) and 176, and the requirements of subpart 2 of part D, which became due on or before November 13, 1992, the date the State

submitted a complete redesignation request.

### B1. Subpart 1 of Part D—Section 172

Section 172(c) sets forth general requirements applicable to all nonattainment areas. Under section 172(b), the section 172(c) requirements are applicable as determined by the Administrator but no later than three years after an area is designated as nonattainment. EPA had not determined that these requirements were applicable to classified O<sub>3</sub> nonattainment areas on or before November 13, 1992, the date that the State of North Carolina submitted a complete redesignation request for the Raleigh/Durham area. Therefore, the State of North Carolina was not required to meet these requirements for purposes of redesignation.

Upon redesignation of this area to attainment, the Prevention of Significant Deterioration (PSD) provisions contained in part C of title I are applicable. On December 30, 1976, and on February 23, 1982, the EPA approved the State of North Carolina's PSD program (41 FR 56805 and 47 FR 78376).

### B2. Subpart 1 of Part D—Section 176 Conformity Plan Provisions

Section 176 of the CAA requires States to develop transportation/air quality conformity procedures which are consistent with federal conformity regulations. Section 176 provides that EPA must develop federal conformity regulations, requiring states to submit these procedures as a SIP revision by November 15, 1992. EPA promulgated final conformity regulations on November 24, 1993 (transportation conformity) and November 30, 1993 (general conformity). Since it was impossible to establish a SIP revision date of November 15, 1992, in these regulations, EPA established a regulatory submittal date of one year after promulgation of the conformity regulations. The State of North Carolina has committed in their maintenance plan to revise the SIP to be consistent with the final federal regulations. In addition, the State Air Quality Section will work closely with the State Department of Transportation (DOT) and local transportation agencies to assure that Transportation Improvement Programs (TIPs) in the maintenance areas are consistent with and conform to the SIP and meet federal requirements on conformity. This review process is being extended to include all major projects regardless of source of funding, as well as all federally funded projects. A complete description of the

conformity review process is included in the TSD prepared for this notice.

### B3. Subpart 2 of Part D

Under section 182(a)(2)(A) areas that retained a designation of nonattainment for O<sub>3</sub> under the amended CAA and that are classified as marginal or above were required to fix their pre-amendment VOC RACT SIPs. North Carolina was not required to submit VOC RACT fixups for purposes of redesignating the Raleigh/Durham area because the Raleigh/Durham area was not nonattainment before the 1990 amendments to the CAA.

Under section 182(b), several requirements were due for moderate O<sub>3</sub> nonattainment areas on November 15, 1992, such as VOC RACT catch-ups, Gasoline Vapor Recovery, New Source Review, and Emission Statements. North Carolina failed to submit these measures for the Raleigh/Durham area. On January 15, 1993, EPA made a finding of failure to submit these measures by letter from Patrick M. Tobin, Acting Regional Administrator, to James B. Hunt, Jr., Governor of North Carolina. However these requirements are not applicable for purposes of considering the State's redesignation request. For purposes of redesignation, EPA must consider whether the State has met all requirements that were applicable prior to the time the state submitted the redesignation request. Since North Carolina submitted the redesignation request for Raleigh/Durham on November 13, 1992, these measures are not relevant for purposes of redesignation. Therefore, all subpart 2 requirements that were applicable at the time the State submitted its redesignation request have been met.

## 3. The Area Has a Fully Approved SIP Under Section 110(k) of the CAA

Based on the approval of provisions under the pre-amended CAA and EPA's prior approval of SIP revisions under the amended CAA, EPA has determined that the Raleigh/Durham area has a fully approved SIP under section 110(k), which also meets the applicable requirements of section 110 and part D as discussed above.

## 4. The Air Quality Improvement Must Be Permanent and Enforceable

Several control measures have come into place since the Raleigh/Durham area violated the O<sub>3</sub> NAAQS. Of these control measures, two control measures produced the most significant decreases in VOC and NO<sub>x</sub> emissions. One control measure is a reduction of fuel volatility, as measured by the Reid Vapor Pressure (RVP), from 10.1 psi in 1988 to 9.0 psi

in 1990 and then to 7.8 psi in the summer of 1992. As a result of the RVP reductions, there has been a reduction of emissions of VOCs of more than 25% from 1988 to 1992 from gasoline powered vehicles of all classes. The other control measure is the improvement in tailpipe emissions associated with the Federal Motor Vehicle Control Program (FMVCP). This program reduces VOC and NO<sub>x</sub> emissions as newer, cleaner vehicles replace older, high emitting vehicles. VOC emissions reductions are 20.9% from 1988 to 1990 and NO<sub>x</sub> emissions reductions are 2.7% from 1988 to 1990.

In association with its emission inventory discussed below, the State of North Carolina has demonstrated that actual enforceable emission reductions are responsible for the recent air quality improvement and that the VOC emissions in the base year are not artificially low due to local economic downturn.

**5. The Area Must Have a Fully Approved Maintenance Plan Pursuant to Section 175A of the Act**

Section 175A of the CAA sets forth the elements of a maintenance plan for

areas seeking redesignation from nonattainment to attainment. The plan must demonstrate continued attainment of the applicable NAAQS for at least ten years after the Administrator approves a redesignation to attainment. Eight years after the redesignation, the state must submit a revised maintenance plan which demonstrates attainment for the ten years following the initial ten-year period. To provide for the possibility of future NAAQS violations, the maintenance plan must contain contingency measures, with a schedule for implementation, adequate to assure prompt correction of any air quality problems.

In this notice, EPA is approving the State of North Carolina's maintenance plan for the Raleigh/Durham area because EPA finds that the State of North Carolina's submittal meets the requirements of section 175A.

**A. Emissions Inventory—Base Year Inventory**

On November 13, 1992, the State of North Carolina submitted comprehensive inventories of VOC, NO<sub>x</sub>, and CO emissions from the Raleigh/Durham area. The inventories

included biogenic, area, stationary, and mobile sources using 1990 as the base year for calculations to demonstrate maintenance. The 1990 inventory is considered representative of attainment conditions because the NAAQS was not violated during 1990. The 1990 Base Year Emission Inventory for the Raleigh/Durham area has been submitted to EPA in SIP Air Pollutant Inventory Management Subsystem (SAMS) format.

The State of North Carolina submittal contains the detailed inventory data and summaries by county and source category. This comprehensive base year emissions inventory was submitted in the SAMS format. Finally, this inventory was prepared in accordance with EPA guidance. A summary of the base year and projected maintenance year inventories are shown in the following three tables. Refer to the TSD prepared for this notice for more in-depth details regarding the base year inventory for the Raleigh/Durham area.

VOC EMISSION INVENTORY SUMMARY

[Tons per day]

	1990	1993	1996	1999	2002	2004
Point .....	12.46	10.05	10.15	10.57	11.03	10.67
Area .....	164.50	162.68	164.10	165.37	167.86	169.74
Mobile .....	85.03	65.37	68.40	72.70	76.39	79.18
<b>Total .....</b>	<b>261.99</b>	<b>238.10</b>	<b>242.65</b>	<b>248.64</b>	<b>255.28</b>	<b>259.59</b>

NO<sub>x</sub> EMISSION INVENTORY SUMMARY

[Tons per day]

	1990	1993	1996	1999	2002	2004
Point .....	3.55	3.74	3.93	4.15	4.28	4.39
Area .....	0.18	0.18	0.18	0.18	0.18	0.18
Mobile .....	89.22	78.86	83.60	83.83	81.35	82.24
<b>Total .....</b>	<b>92.95</b>	<b>82.78</b>	<b>87.71</b>	<b>88.16</b>	<b>85.81</b>	<b>86.81</b>

CO EMISSION INVENTORY SUMMARY

[Tons per day]

	1990	1993	1996	1999	2002	2004
Point .....	1.00	1.05	1.10	1.15	1.20	1.22
Area .....	32.54	32.58	32.61	32.65	32.68	32.70
Mobile .....	624.97	497.74	514.10	531.51	560.27	583.27
<b>Total .....</b>	<b>658.51</b>	<b>531.37</b>	<b>547.81</b>	<b>565.31</b>	<b>594.15</b>	<b>617.19</b>

#### B. Demonstration of Maintenance— Projected Inventories

Total VOC, NO<sub>x</sub>, and CO emissions were projected from the 1990 base year out to 2004. These projected inventories were prepared in accordance with EPA guidance. Refer to EPA's TSD prepared for this notice for more in-depth details regarding the projected inventory for the Raleigh/Durham area.

On January 12, 1994, the State of North Carolina submitted supplemental projection inventories. The State recalculated growth rates to include 1992 Vehicle Miles Traveled (VMT) data received in late 1993 from the North Carolina Department of Transportation. The projections indicate that VOC, NO<sub>x</sub>, and CO emissions remain under the 1990 baseline emission inventory from 1990 through 2004. EPA believes that the emissions projections demonstrate that the area will continue to maintain the O<sub>3</sub> NAAQS because this area achieved attainment through VOC controls and reductions. The projected emission inventories were submitted in the SAMS format.

#### C. Verification of Continued Attainment

Continued attainment of the O<sub>3</sub> NAAQS in the Raleigh/Durham area depends, in part, on the State of North Carolina's efforts toward tracking indicators of continued attainment during the maintenance period. The State of North Carolina's contingency plan is triggered by two indicators, an air quality violation or the periodic emissions inventory exceeding the baseline emission inventory by more than 10%. As stated in the maintenance plan, the NCDEHNR will be developing these periodic emissions inventories every three years beginning in 1996. These periodic inventories will help to verify continued attainment. Refer to the TSD prepared for this notice for a more complete discussion of the indicators the State is tracking and the contingency measures.

#### D. Contingency Plan

The level of VOC and NO<sub>x</sub> emissions in the Raleigh/Durham area will largely determine its ability to stay in compliance with the O<sub>3</sub> NAAQS in the future. Despite the State's best efforts to demonstrate continued compliance with the NAAQS, the ambient air pollutant concentrations may exceed or violate the NAAQS. Therefore, the State of North Carolina has provided contingency measures with a schedule for implementation in the event of a future O<sub>3</sub> air quality problem. The plan contains a contingency to implement pre-adopted additional control measures

such as Reasonable Available Control Technology (RACT) level control for not previously controlled VOC sources, Stage II vapor control for gasoline dispensing facilities, and new source permit requirements for VOC and NO<sub>x</sub> emissions to include emission offsets, Lowest Achievable Emission Rate (LAER) level control, and permit applicability. These pre-adopted additional measures will be implemented within 45 days of the date the State certifies to EPA that the air quality data which demonstrates a violation of the O<sub>3</sub> NAAQS is quality assured. The plan also contains a secondary trigger that will apply where no actual violation of the NAAQS has occurred. The secondary trigger is an exceedance of the baseline emissions inventory by more than 10%. On the occurrence of the secondary trigger, the State will commence, within 60 days of the trigger, regulation development and adoption of measures amending the State vehicle inspection and maintenance (I/M) program, extending coverage of the I/M program, extending and/or lowering vapor pressure limits for gasoline, extending geographic coverage of RACT controls, transportation control measures, and RACT level control for NO<sub>x</sub>. A complete description of these contingency measures and their triggers can be found in the TSD prepared for this notice. EPA finds that the contingency measures provided in the State of North Carolina submittal meet the requirements of section 175A(d) of the CAA.

#### E. Subsequent Maintenance Plan Revisions

In accordance with section 175A(b) of the CAA, the State of North Carolina has agreed to submit a revised maintenance SIP eight years after the area is redesignated to attainment. Such revised SIP will provide for maintenance for an additional ten years.

#### Final Action

In this final action, EPA is approving the Raleigh/Durham O<sub>3</sub> maintenance plan, including the 1990 base year emission inventory, because it meets the requirements of section 175A. In addition, the EPA is redesignating the Raleigh/Durham area to attainment for O<sub>3</sub> because the State of North Carolina has demonstrated compliance with the requirements of section 107(d)(3)(E) for redesignation. This action stops the sanctions and federal implementation plan clocks that were triggered for the Raleigh/Durham area by the January 15, 1993, findings letter. Nothing in this action should be construed as permitting or allowing or establishing a

precedent for any future request for revision to any SIP. Each request for revision to the SIP shall be considered separately in light of specific technical, economic, and environmental factors and in relation to relevant statutory and regulatory requirements.

The O<sub>3</sub> SIP is designed to satisfy the requirements of part D of the CAA and to provide for attainment and maintenance of the O<sub>3</sub> NAAQS. This final redesignation should not be interpreted as authorizing the State of North Carolina to delete, alter, or rescind any of the VOC or NO<sub>x</sub> emission limitations and restrictions contained in the approved O<sub>3</sub> SIP. Changes to O<sub>3</sub> SIP VOC regulations rendering them less stringent than those contained in the EPA approved plan cannot be made unless a revised plan for attainment and maintenance is submitted to and approved by EPA. Unauthorized relaxations, deletions, and changes could result in a finding of nonimplementation (section 173(b) of the CAA) or in a SIP deficiency call made pursuant to section 110(a)(2)(H) of the CAA.

Under the Regulatory Flexibility Act, 5 U.S.C. 600 et seq., EPA must prepare a regulatory flexibility analysis assessing the impact of any proposed or final rule on small entities. 5 U.S.C. 603 and 604. Alternatively, EPA may certify that the rule will not have a significant impact on a substantial number of small entities. Small entities include small businesses, small not-for-profit enterprises, and government entities with jurisdiction over populations of less than 50,000.

Redesignation of an area to attainment under section 107(d)(3)(E) of the CAA does not impose any new requirements on small entities. Redesignation is an action that affects the status of a geographical area and does not impose any regulatory requirements on sources. The Administrator certifies that the approval of the redesignation request will not affect a substantial number of small entities.

This action is being taken without prior proposal because the changes are noncontroversial and EPA anticipates no significant comments on them. The public should be advised that this action will be effective June 17, 1994. If, however, notice is received by May 18, 1994 that someone wishes to submit adverse or critical comments, this action will be withdrawn and two subsequent notices will be published before the effective date. One will withdraw the final action and the other will begin a new rulemaking by announcing a comment period.



Under section 307(b)(1) of the CAA, 42 U.S.C. 7607 (b)(1), petitions for judicial review of this action must be filed in the United States Court of Appeals for the appropriate circuit by June 17, 1994. Filing a petition for reconsideration by the Administrator of this final rule does not affect the finality of this rule for purposes of judicial review nor does it extend the time within which a petition for judicial review may be filed, and shall not postpone the effectiveness of such rule or action. This action may not be challenged later in proceedings to enforce its requirements. (See section 307(b)(2) of the CAA, 42 U.S.C. 7607 (b)(2).)

This action has been classified as a Table 2 action by the Regional Administrator under the procedures published in the Federal Register on January 19, 1989, (54 FR 2214-2225) as revised by a Memorandum from Michael H. Shapiro to Regional Administrators, dated October 4, 1993. On January 6, 1989, the Office of Management and Budget (OMB) waived Table 2 and 3 SIP revisions (54 FR 2222) from the requirements of section 3 of Executive Order 12291 for two years. The U.S. EPA has submitted a request for a permanent waiver for Table 2 and Table 3 SIP revisions. OMB has agreed to continue the temporary waiver until such time as it rules on EPA's request. This request continues in effect under Executive Order 12866 which superseded Executive Order 12291 on September 30, 1993.

Nothing in this action shall be construed as permitting or allowing or establishing a precedent for any future request for a revision to any state

implementation plan. Each request for revision to the state implementation plan shall be considered separately in light of specific technical, economic, and environmental factors and in relation to relevant statutory and regulatory requirements.

**List of Subjects**

**40 CFR Part 52**

Air pollution control, Hydrocarbons, Incorporation by reference, Intergovernmental relations, and Ozone.

**40 CFR Part 81**

Air pollution control, National parks, and Wilderness areas.

Dated: March 11, 1994.

**Patrick M. Tobin,**  
*Acting Regional Administrator.*

Part 52 of chapter I, title 40, Code of Federal Regulations, is amended as follows:

**Part 52—[AMENDED]**

1. The authority citation for part 52 continues to read as follows:

**Authority:** 42 U.S.C. 7401-7671q.

2. Section 52.1770 is amended by adding paragraph (c)(67) to read as follows:

**§ 52.1770 Identification of plan.**

\* \* \* \* \*

(c) \* \* \*

(67) The maintenance plan and emission inventory for the Raleigh/Durham Area which includes Durham County, Wake County, and the Dutchville Township portion of Granville County submitted by the North Carolina Department of Environment, Health, and Natural

Resources on November 13, 1992, and June 1, 1993, as part of the North Carolina SIP.

(i) Incorporation by reference.

(A) Supplement to the Redesignation Demonstration and Maintenance Plan for the Greensboro/Winston-Salem/High Point and Raleigh/Durham Ozone Attainment Areas submitted June 1, 1993, and Prepared by the North Carolina Department of Environment, Health, and Natural Resources, Division of Environmental Management, Air Quality Section. The effective date is July 8, 1993.

(1) Section 2—Discussion of Attainment.

(2) Section 3—Maintenance Plan.

(3) Raleigh/Durham Nonattainment Area Emission Summary for 1990.

(4) Raleigh/Durham Nonattainment Area Emission Summary for 1993.

(5) Raleigh/Durham Nonattainment Area Emission Summary for 1996.

(6) Raleigh/Durham Nonattainment Area Emission Summary for 1999.

(7) Raleigh/Durham Nonattainment Area Emission Summary for 2002.

(8) Raleigh/Durham Nonattainment Area Emission Summary for 2004.

(ii) Other material. None

**Part 81—[AMENDED]**

1. The authority citation for part 81 continues to read as follows:

**Authority:** 42 U.S.C. 7401-7671q.

2. Section 81.334, is amended by revising the attainment status designation table for ozone to read as follows:

**§ 81.334 North Carolina.**

\* \* \* \* \*

**NORTH CAROLINA—OZONE**

	Designation		Classification	
	Date <sup>1</sup>	Type	Date <sup>1</sup>	
Charlotte-Gastonia Area:				
Gaston County .....		Nonattainment .....		Moderate.
Mecklenburg County .....		Nonattainment .....		Moderate.
Rest of State .....		Unclassifiable/Attainment.		
Alamance County.				
Alexander County.				
Alleghany County.				
Anson County.				
Ashe County.				
Avery County.				
Beaufort County.				
Bertie County.				
Bladen County.				
Brunswick County.				
Buncombe County.				
Burke County.				
Cabarrus County.				
Caldwell County.				
Camden County.				
Carteret County.				

NORTH CAROLINA—OZONE—Continued

	Designation		Classification	
	Date <sup>1</sup>	Type	Date <sup>1</sup>	
Caswell County.				
Catawba County.				
Chatham County.				
Cherokee County.				
Chowan County.				
Clay County.				
Cleveland County.				
Columbus County.				
Craven County.				
Cumberland County.				
Currituck County.				
Dare County.				
Davidson County .....	September 9, 1993.			
Davie County .....	September 9, 1993.			
Durham County .....	June 17, 1994.			
Duplin County.				
Edgecombe County.				
Forsyth County .....	September 9, 1993.			
Franklin County.				
Gates County.				
Graham County.				
Granville County .....	June 17, 1994.			
Greene County.				
Guilford County .....	September 9, 1993.			
Halifax County.				
Harnett County.				
Haywood County.				
Henderson County.				
Hertford County.				
Hoke County.				
Hyde County.				
Iredell County.				
Jackson County.				
Johnston County.				
Jones County.				
Lee County.				
Lenoir County.				
Lincoln County.				
McDowell County.				
Macon County.				
Madison County.				
Martin County.				
Mitchell County.				
Montgomery County.				
Moore County.				
Nash County.				
New Hanover County.				
Northhampton County.				
Onslow County.				
Orange County.				
Pamlico County.				
Pasquotank County.				
Pender County.				
Perquimans County.				
Person County.				
Pitt County.				
Polk County.				
Randolph County.				
Richmond County.				
Robeson County.				
Rockingham County.				
Rowan County.				
Rutherford County.				
Sampson County.				
Scotland County.				
Stanly County.				
Stokes County.				
Surry County.				
Swain County.				
Transylvania County.				

NORTH CAROLINA—OZONE—Continued

	Designation		Classification	
	Date <sup>1</sup>	Type	Date <sup>1</sup>	
Tyrrell County. Union County. Vance County. Wake County ..... Warren County. Washington County. Watauga County. Wayne County. Wilkes County. Wilson County. Yadkin County. Yancey County.	June 17, 1994.			

<sup>1</sup> This date is November 15, 1990, unless otherwise noted.

\* \* \* \* \*

[FR Doc. 94-8967 Filed 4-15-94; 8:45 am]  
BILLING CODE 6560-50-P

40 CFR Part 52

[Region II Docket No. 104, VI1-1-5096;  
FRL-4827-6]

Approval and Promulgation of  
Implementation Plans; Revision to the  
U.S. Virgin Islands Implementation  
Plan

AGENCY: Environmental Protection  
Agency.

ACTION: Final rule.

**SUMMARY:** With one exception, the Environmental Protection Agency (EPA) is approving a request from the U.S. Virgin Islands to revise its air pollution control plan prepared under the Clean Air Act to include a comprehensive revision to the Virgin Islands' air pollution control regulations.

EPA is approving a special 1.5 percent sulfur content limit for residual fuel oil used by two specific sources, however, EPA is disapproving this special limit for Martin Marietta, St. Croix (now known as Virgin Islands Alumina Corporation).

EPA is approving subsections 204-40(e) of "Reports, Sampling and Analysis of Waste Fuels A and B," and 206-25(c) of "Test Methods." However, these provisions permit the Commissioner to approve alternate requirements that are not incorporated in the Virgin Islands Implementation Plan. Any variances adopted pursuant to these subsections become applicable only if approved by EPA.

**EFFECTIVE DATE:** This action will be effective May 18, 1994.

**ADDRESSES:** Copies of the materials submitted by the Virgin Islands may be

examined during normal business hours at the following locations:

U.S. Environmental Protection Agency,  
Library, 26 Federal Plaza, room 402,  
New York, New York 10278  
Government of the Virgin Islands,  
Department of Planning and Natural  
Resources, Building 111, Apartment  
114, Water Gut Homes, Christiansted,  
St. Croix 00820  
Government of the Virgin Islands,  
Department of Planning and Natural  
Resources, 45A Estate Nisky, Nisky  
Center, suite 231, St. Thomas 00820  
Environmental Protection Agency, Air  
Docket, 6102, 401 M Street, SW.,  
Washington, DC 20460.

**FOR FURTHER INFORMATION CONTACT:**  
William Baker, Chief, Air Programs  
Branch, U.S. Environmental Protection  
Agency, 26 Federal Plaza, room 1034B,  
New York, New York 10278, (212) 264-  
2517.

**SUPPLEMENTARY INFORMATION:** On March 20, 1987, the Virgin Islands Department of Planning and Natural Resources (DPNR) submitted revisions to title 12, chapter 9, subchapters 204 and 206 of the Virgin Islands Code, effective January 15, 1987, to the Environmental Protection Agency (EPA) for incorporation into the Virgin Islands Implementation Plan. Specific revisions to Subchapter 204 included the amending of sections 204-20 through 204-23, 204-25, 26, 28, 29 and the addition of new sections 204-33, 35, 36, 37, 38, 39, 40, 41 and 45. Specific revisions to subchapter 206 include amending and redesignating sections 206-23 through 206-30 as sections 206-24 through 206-31, and the addition of a new section 206-23. The DPNR held public hearings on these revisions in St. Thomas on September 8 and 9, 1986.

On December 14, 1989 (54 FR 51303), EPA published a **Federal Register** notice proposing to approve all but one of the comprehensive revisions to the Virgin

Islands' submittal. Specifically, EPA proposed to disapprove subsection 204-26(a)(2), which allowed a special 1.5 percent sulfur in residual fuel limit for Martin Marietta, now known as Virgin Islands Alumina Corporation. The December 14, 1989 **Federal Register** notice solicited comments on the revised regulations and EPA's proposed action in response to the revisions. No comments were received.

EPA is approving the revised regulations as part of the Virgin Islands Implementation Plan except for the disapproval of subsection 204-26(a)(2) as it relates to Martin Marietta (VI Alumina Corporation). In subsection 204-26(a)(2) the maximum allowable sulfur content of distillate and residual oil expressed in percent by weight are now 0.3 and 0.5, respectively, for all of the Virgin Islands except for the special 1.5 percent sulfur content limit for residual fuel oil used by two specific sources (Hess Oil in St. Croix and Virgin Islands Water and Power Authority in St. Thomas).

It should be noted that EPA also is taking action at this time to approve a control strategy demonstration for sulfur dioxide as it relates to the Virgin Islands Water and Power Authority (VIWAPA) plant in St. Croix, based on the attainment demonstration included in its Prevention of Significant Deterioration of Air Quality (PSD) permit application. EPA has received and approved the PSD permit attainment demonstration, which conforms to EPA's "Guideline on Air Quality Models (Revised 1986)."

On December 28, 1992, EPA approved a PSD permit for four units at VIWAPA's north shore facility in St. Croix. A revised attainment demonstration required to be included in the permit application specified a 0.33 percent sulfur content limit in No. 6 residual fuel oil for the two existing

boilers and a 0.2 percent sulfur content limit in No. 2 distillate fuel oil in the remaining units. Although a 0.5 percent sulfur content limit in residual fuel oil and a 0.3 percent sulfur content limit in distillate fuel oil for the VIWAPA plant in St. Croix are included in subsection 204-26(a)(2) and approved under this action, this limit has been superseded by the limits contained in VIWAPA's PSD permit. The PSD permit meets all applicable requirements of the PSD regulations codified in 40 CFR 52.21 and the Clean Air Act.

On August 12, 1986 EPA sent a letter to the Governor of the Virgin Islands notifying him that the Virgin Island Implementation Plan was substantially inadequate to achieve and maintain the National Ambient Air Quality Standards (NAAQS) for sulfur dioxide as it relates to VIWAPA's north shore facility in St. Croix. EPA's approval of the lower sulfur in fuel oil limitations included in the PSD permit for VIWAPA and the State Implementation Plan (SIP) revision rectify this inadequacy and is consistent with the Clean Air Act Amendments (Act), enacted on November 15, 1990, requirements of attaining and maintaining the NAAQS for sulfur dioxide.

EPA also is approving section 204-28, which establishes new opacity limits for internal combustion engines, and section 204-37, which provides for the regulated use of waste fuel oils. These approvals are based on certain understandings which were described in EPA's proposal. Approval of section 204-25, which regulates sources of fugitive emissions, is based upon EPA's definition of the term "fugitive emissions," since the existing and revised regulations did not include a definition of this term.

EPA is approving subsections 204-40(e) and 206-25(c) where methods other than the Reference Methods contained in parts 60 and 61 of title 40 of the Code of Federal Regulations (40 CFR) are used to demonstrate compliance. These subsections permit the Commissioner to approve alternate requirements in those instances where the source is unable to make use of the reference methods. They are intended to allow the Commissioner to respond to situations which were not envisioned when the specific requirements were adopted, yet insure that the source complies with the intent of the regulation. While EPA understands the need for such provisions, any changes which affect the SIP approved emission limits used to demonstrate attainment and maintenance of the NAAQS must be federally enforceable and, therefore, must be addressed through revisions to

the SIP. EPA can only accept alternate requirements if these changes are approved by EPA.

EPA also is revising the Table at 40 CFR 52.2773, "EPA-approved Virgin Islands regulations," to reflect these newly adopted regulations. The Table previously referenced the date the regulation was submitted, but has now been changed to refer to the date when the regulation became effective.

Sections 206-30 and 206-31 have been renumbered to Sections 206-31 and 206-32, respectively. EPA's previous determination concerning their approvability remains, along with the previous effective and approved dates.

This SIP revision is intended to strengthen the Virgin Islands Implementation Plan, (especially with regard to sulfur dioxide and particulates), by incorporating revised and new regulations which are consistent with the Act as interpreted in current EPA guidance. Although this SIP revision was not intended to fulfill any specific provision of the Act, EPA is approving the revision under section 110 of the Act, because it serves to strengthen the Virgin Islands Implementation Plan and it is consistent with the Act's requirements for attaining and maintaining the NAAQS for sulfur dioxide and particulate matter.

#### Conclusion

EPA is approving a special 1.5 percent sulfur content limit for residual fuel oil used by two specific sources, however, EPA is disapproving this special limit for Martin Marietta, St. Croix (VI Alumina Corporation). Martin Marietta, St. Croix (VI Alumina Corporation) is required to burn the maximum allowable sulfur content of distillate and residual oil expressed in percent by weight of 0.3 and 0.5, respectively, in order to meet the PSD requirements specified in part C of the Act.

EPA is approving subsections 204-40(e) of "Reports, Sampling and Analysis of Waste Fuels A and B," and 206-25(c) of "Test Methods." However, these provisions permit the Commissioner to approve alternate requirements that are not incorporated in the SIP. Any variances adopted pursuant to these subsections become applicable only if approved by EPA.

EPA's approval of the SIP revision, specifically the lower sulfur in fuel oil limitations and modeling demonstration for St. Croix included in the PSD permit for VIWAPA, rectify the SIP inadequacy to achieve and maintain the primary NAAQS for sulfur dioxide identified in the August 12, 1986 letter sent to the Governor of the Virgin Islands.

This notice is issued as required by section 110 of the Act. The Regional Administrator's decision regarding the approval of this plan revision is based on its meeting the requirements of section 110 of the Act and 40 CFR part 51.

Nothing in this rule should be construed as permitting, allowing or establishing a precedent for any future request for revision to any SIP. Each request for a revision to the SIP shall be considered separately in light of specific technical, economic, and environmental factors and in relation to relevant statutory and regulatory requirements.

This rule makes final the action proposed at 54 FR 51303, December 14, 1989. As noted elsewhere in this notice, EPA received no adverse public comments on the proposed rule. As a direct result, the Regional Administrator has reclassified this rule from Table 1 to Table 2 under the processing procedures established at 54 FR 2214, January 19, 1989. EPA has submitted a request for a permanent waiver for Table 2 and Table 3 SIP revisions. The Office of Management and Budget has agreed to continue the temporary waiver until such time as it rules on EPA's request.

Under section 307(b)(1) of the Act, petitions for judicial review of this rule must be filed in the United States Court of Appeals for the appropriate circuit within 60 days from date of publication. Filing a petition for reconsideration by the Administrator of this final rule does not affect the finality of this rule for the purposes of judicial review nor does it extend the time within which a petition for judicial review may be filed, and shall not postpone the effectiveness of such rule or action. This rule may not be challenged later in proceedings to enforce its requirements. (See 307(b)(2).)

#### List of Subjects in 40 CFR Part 52

Air pollution control, Hydrocarbons, Particulate matter, Reporting and recordkeeping requirements, Sulfur oxides, Nitrogen dioxide.

**Editorial Note:** This document was received by the Office of the Federal Register on April 8, 1994.

Dated: December 30, 1993.

**William J. Muszynski,**  
*Acting Regional Administrator.*

Title 40, chapter I, part 52, Code of Federal Regulations is amended as follows:

#### PART 52—APPROVAL AND PROMULGATION OF IMPLEMENTATION PLANS

1. The authority citation for part 52 continues to read as follows:

**Authority:** 42 U.S.C. 7401-7671q.

**Subpart CCC—Virgin Islands**

2. Section 52.2770 is amended by adding new paragraph (c)(17) as follows:

**§ 52.2770 Identification of plan.**

\* \* \* \* \*  
(C) \* \* \*  
\* \* \* \* \*

(17) Comprehensive revisions to Virgin Islands air pollution control regulations submitted on March 20,

1987 by the Virgin Islands Department of Planning and Natural Resources.

(i) Incorporation by reference:  
(A) Revised sections 20 through 23, 25, 26, 28, 29, 33, 35 through 41, and 45 of subchapter 204, chapter 9, title 12 of the Virgin Islands Code, effective January 15, 1987.

(B) Revised sections 20 through 31 of subchapter 206, chapter 9, title 12 of the Virgin Islands Code, effective January 15, 1987.

(ii) Additional material:

(A) July 1988 Modeling Analysis for CEC Energy Co., Inc.

(B) July 11, 1989 letter from Ted Helgott, Amerada Hess Corporation to Raymond Werner, U.S. Environmental Protection Agency, Region II, New York.

(C) December 28, 1992 Prevention of Significant Deterioration of Air Quality permit for Virgin Islands Water and Power Authority at St. Croix's north shore facility.

3. Section 52.2773 is revised to read as follows:

**§ 52.2773 EPA-APPROVED VIRGIN ISLANDS REGULATIONS**

Territory regulation	Effective date	EPA approval date	Comments
Section 204-20, "Definitions" .....	1/15/87	[Date and citation of this notice] .....	"Fugitive emissions" will be defined as at 40 CFR 52.21(b)(20).
Section 204-21, "Regulations to Control Open Burning".	1/15/87	[Date and citation of this notice].	
Section 204-22, "Regulations to Control Emission of Visible Air Contaminants".	1/15/87	[Date and citation of this notice].	
Section 204-23, "Regulations Governing Emission of Particulate Matter".	1/15/87	[Date and citation of this notice].	
Section 204-24, "Storage of Petroleum or Other Volatile Products".	3/2/71	5/31/72, 37 FR 10905.	
Section 204-25, "Fugitive Emissions" .....	1/15/87	[Date and citation of this notice].	
Section 204-26, "Sulfur Compounds Emission Control".	1/15/87	[Date and citation of this notice] .....	Subsection 204-26(a)(2) is disapproved for three Martin Marietta (VI Alumina Corp), St. Croix, sources. For applicable limits, refer to PSD permit for the facility.
Section 204-27, "Air Pollution Nuisances Prohibited".	3/2/71	5/31/72, 37 FR 10905.	
Section 204-28, "Internal Combustion Engine Limits".	1/15/87	[Date and citation of this notice].	
Section 204-29, "Upset, Breakdown or Scheduled Maintenance".	1/15/87	[Date and citation of this notice].	
Section 204-30, "Circumvention" .....	3/2/71	5/31/72, 37 FR 10905.	
Section 204-31, "Duty to Report Discontinuation or Dismantlement".	3/2/71	5/31/72, 37 FR 10905.	
Section 204-32, "Variance Clauses" .....	3/2/71	5/31/72, 37 FR 10905.	
Section 204-33, "Air Pollution Emergencies".	1/15/87	[Date and citation of this notice].	
Section 204-35, "Continuous Emission Monitoring".	1/15/87	[Date and citation of this notice].	
Section 204-36, "Eligibility to Burn Waste Fuel A".	1/15/87	[Date and citation of this notice].	
Section 204-37, "Eligibility to Burn Waste Fuels A and B".	1/15/87	[Date and citation of this notice].	
Section 204-38, "Permit and/or Certificate Requirement for Waste Oil Facilities".	1/15/87	[Date and citation of this notice].	
Section 204-39, "Sale or Use of Waste Fuels A and B".	1/15/87	[Date and citation of this notice] .....	Reference to Table 1 in this subsection refers to Table 1 found in Section 204-20.
Section 204-40, "Reports, Sampling and Analysis of Waste Fuels A and B".	1/15/87	[Date and citation of this notice] .....	Variances adopted pursuant to subsection 204-40(e) become applicable only if approved by EPA as SIP revisions.
Section 204-41, "Existing Air Contamination Sources for Waste Fuel".	1/15/87	[Date and citation of this notice].	
Section 204-45, "Standards of Performance for Sulfur Recovery Units at Petroleum Refineries".	1/15/87	[Date and citation of this notice].	
Section 206-20, "Permits Required" .....	1/15/87	[Date and citation of this notice].	
Section 206-21, "Transfer" .....	1/15/87	[Date and citation of this notice].	
Section 206-22, "Applications" .....	1/15/87	[Date and citation of this notice].	
Section 206-23, "Application and Permit Fees".	1/15/87	[Date and citation of this notice].	
Section 206-24, "Cancellation of Applications".	1/15/87	[Date and citation of this notice].	

## § 52.2773 EPA-APPROVED VIRGIN ISLANDS REGULATIONS—Continued

Territory regulation	Effective date	EPA approval date	Comments	
Section 206-25, "Test Methods" .....	1/15/87	[Date and citation of this notice] .....	Variances adopted pursuant to subsection 206-25(c) become applicable only if approved by EPA as SIP revisions.	
Section 206-26, "Permits to Construct" ...	1/15/87	[Date and citation of this notice].		
Section 206-27, "Permits to Operate" .....	1/15/87	[Date and citation of this notice].		
Section 206-28, "Permit Modifications, Suspensions or Revocations and Denials".	1/15/87	[Date and citation of this notice].		
Section 206-29, "Further Information" .....	1/15/87	[Date and citation of this notice].		
Section 206-30, "Appeals" .....	1/15/87	[Date and citation of this notice].	Subsection 206-30(f)(6) is disapproved since sources of minor significance are not identified in Section 206-30. A federally promulgated regulation (40 CFR 52.2775(g)), correcting this deficiency and a public participation deficiency, is applicable.	
Section 206-30, "Review of New Sources and Modifications".	10/11/73	8/10/75, 40 FR 42013 .....		Two separate subsections are numbered 206-30 and are listed here with their separate titles.
Section 206-31, "Review of New or Modified Indirect Sources".	10/11/73	8/10/75, 40 FR 42013.		

[FR Doc. 94-8972 Filed 4-15-94; 8:45 am]  
BILLING CODE 6560-50-P

## 40 CFR Part 52

[TN-98-1-5644; TN-103-1-6087; TN-108-1-6088; TN-109-1-6089; FRL-4860-5]

**Approval and Promulgation of Implementation Plans Tennessee: Approval of Revisions to the Portion of the State Implementation Plan Regulating Volatile Organic Compounds and Determining General Alternate Emission Standards**

**AGENCY:** Environmental Protection Agency (EPA).

**ACTION:** Final rule.

**SUMMARY:** On June 25, 1992, and March 22, 1993, the State of Tennessee through the Department of Environment and Conservation submitted revisions to its State Implementation Plan (SIP) regarding general definitions, control of volatile organic compounds (VOCs), and general alternate emission standards.

On November 5, 1992, and April 22, 1993, the State submitted revisions to the VOC regulations and general alternate emission standards in the Memphis-Shelby County portion of the Tennessee SIP on behalf of Memphis-Shelby County. Since Memphis-Shelby County adopts the State's regulations by reference, the submitted SIP revisions were essentially identical to the regulations in the State's submittal.

EPA is approving or conditionally approving revisions to the Tennessee

SIP and the Memphis-Shelby County portion of the Tennessee SIP as meeting the requirements of the Clean Air Act as amended in 1990 (CAA). The State and Memphis submittals addressed, or committed to address, all of the deficiencies identified in the State's VOC regulations and documented by EPA in letters to the State dated November 9, 1987, June 10, 1987, and January 25, 1990, and to Memphis-Shelby County dated November 9, 1987. EPA is disapproving the deletion of rule 1200-3-18-.03 Standard for New Sources.

**DATES:** This final rule will be effective June 17, 1994 unless notice is received by May 18, 1994 that someone wishes to submit adverse or critical comments. If the effective date is delayed, timely notice will be published in the Federal Register.

**ADDRESSES:** Copies of the material submitted by the State of Tennessee may be examined during normal business hours at the following locations:

Air and Radiation Docket and Information Center (Air Docket 6102), U.S. Environmental Protection Agency, 401 M Street, SW., Washington, DC 20460.

Region IV, Air Programs Branch, Environmental Protection Agency, 345 Courtland Street, Atlanta, Georgia 30365.

Division of Air Pollution Control, Tennessee Department of Environment and Conservation, L & C Annex, 9th Floor, 401 Church Street, Nashville, Tennessee 37243-1531.

Air Pollution Control Section, Memphis-Shelby County Health Department, 814 Jefferson Avenue, room 437, Memphis, Tennessee 38105.

**FOR FURTHER INFORMATION CONTACT:** William Denman, Air Programs Branch, United States Environmental Protection Agency, 345 Courtland Street, Atlanta, Georgia 30365, (404) 347-2864.

**SUPPLEMENTARY INFORMATION:** In May 1988, EPA released 1987 air quality data which established the degree to which areas throughout the Nation attained, or failed to attain, the ozone National Ambient Air Quality Standard (NAAQS) and issued SIP calls for areas that failed to attain. The Memphis and Nashville areas in Tennessee failed to attain the ozone NAAQS. On September 7, 1988, at 53 FR 34500, EPA gave notice that SIP calls were made to the nonattainment areas.

The SIP call letters, which were sent to Governors and State Air Pollution Control Directors, requested that the states respond to the SIP calls in two phases. The response to Phase I was due approximately one year following the issuance of final EPA policy program requirements for ozone and carbon monoxide nonattainment areas and/or reauthorization of the CAA. As part of the first phase, states were asked to upgrade SIPs to correct discrepancies in existing SIPs as compared with EPA's existing guidance under section 108 and part D (related to reasonably available control technology (RACT) for VOC emissions) and to adopt control measures to satisfy any commitments in

the part D SIP's to adopt RACT measures.

In 1990, Congress amended the CAA to address, among other things, continued nonattainment of the ozone NAAQS (Public Law 101-549, 104 Stat. 2399, codified at 42 U.S.C. 7401-7671q). Section 182(a)(2)(A) of the CAA requires states with existing areas designated nonattainment for ozone and classified as at least marginal, to submit, by May 15, 1991, revisions to the SIP that correct or add requirements concerning RACT in accordance with pre-amendment guidance.<sup>1</sup> The SIP call letters interpreted that guidance and indicated the corrections necessary for specific nonattainment areas.

The Memphis area is classified as marginal nonattainment and the Nashville area is classified as moderate nonattainment<sup>2</sup> for the ozone NAAQS. Therefore, these areas are subject to the RACT fix-up requirement and the May 15, 1991, deadline.

Tennessee failed to meet the May 15, 1991, deadline for the submittal of corrections to the State (including the State's portion of the Nashville nonattainment area), Memphis-Shelby County, and some of the Nashville-Davidson County regulations<sup>3</sup>. EPA notified the State on June 25, 1991, that a finding of failure to submit had been made for the Memphis-Shelby County and Nashville nonattainment areas. This finding of failure to submit was published at 56 FR 54557 on October 22, 1991. The finding triggered the 18-month time clock for mandatory application of sanctions under section 179(a) of the CAA and the 2-year time clock for promulgation of Federal VOC regulations for nonattainment areas as required by section 110(c)(1).

The State submitted revisions to the Tennessee SIP, including Nashville, to EPA on June 25, 1992, and on March 22, 1993. The State submitted SIP revisions to meet the section 182(a)(2)(A) requirement on behalf of Memphis-Shelby County on November 5, 1992,

and on April 22, 1993. EPA found these submittals to be complete on October 6, 1993, and June 9, 1993, respectively. This finding of completeness stopped the sanctions clock started on October 22, 1991, for the Memphis-Shelby County and Nashville nonattainment areas. However, the Federal Implementation Plan (FIP) clock continued to run. EPA's final approval action relieves EPA of the FIP obligation for those portions of the submittal that are being fully approved. EPA is approving the following revisions except where it is specifically noted that the revision is being conditionally approved or disapproved.

#### Chapter 1200-3-2 General Definitions

The following changes were made only to the Tennessee portion of the SIP, and not to the Memphis portion.

##### Rule 1200-3-2-.01 General Definitions

The definition of "air contaminant source" was revised to correct a typographical error. The revision added the phrase "portable fuel-burning equipment, and incinerators of all types, indoor and," to the definition of "air contaminant source."

The definitions of "air curtain destructor," "open burning," "Ringelmann chart," "soiling index," "silicon carbide plant," and "magnetite processing plant" were deleted.

Minor changes were made to the definitions of "modification" and "reasonably available control technology" to correct typographical errors and for clarification.

The definition of "malfunction" was revised to correct a typographical error. The revision added failures that are caused by poor maintenance, careless operation, or any other preventable upset condition to the definition of "malfunction."

The definition of "startup" was revised to specify that "startup is the setting in operation of an air contaminant source for the production of product for sale or use as raw materials or steam or heat production."

Definitions of "continuous emission monitor," "nonattainment area," "PM-10," and "total suspended particulate (TSP)" were added.

Minor revisions to the definitions of "air pollution," "board," and "cupola" were withdrawn by the State via letter dated January 11, 1993, from Mr. John W. Walton, Technical Secretary of the Tennessee Air Pollution Control Board.

#### Chapter 1200-3-18 Volatile Organic Compounds

*Applicability*—The applicability requirements have been revised to state

that the rules apply to facilities having potential VOC emissions of 25 tons per year or greater in Davidson, Hamilton, and Shelby Counties, and 100 tons per year or greater in all other counties in the State. The applicability requirements have been revised in the following rules.

- Rule 1200-3-18-.05 Automobile and Light Duty Truck Manufacturing;
- Rule 1200-3-18-.12 Can Coating;
- Rule 1200-3-18-.13 Coil Coating;
- Rule 1200-3-18-.14 Fabric and Vinyl Coating;
- Rule 1200-3-18-.15 Metal Furniture Coating;
- Rule 1200-3-18-.16 Surface Coating of Large Appliances;
- Rule 1200-3-18-.17 Magnet Wire Coating;
- Rule 1200-3-18-.18 Solvent Metal Cleaning;
- Rule 1200-3-18-.20 Flat Wood Paneling Coating;
- Rule 1200-3-18-.21 Surface Coating of Miscellaneous Metal Parts and Products;
- Rule 1200-3-18-.26 Manufacture of Pneumatic Rubber Tires;
- Rule 1200-3-18-.27 Manufacture of Synthesized Pharmaceutical Products; and
- Rule 1200-3-18-.28 Perchloroethylene Dry Cleaning.

*Compliance*—The following rules have been revised to reference the compliance provisions in paragraph 1200-3-18-.01(3) and rule 1200-3-18-.22. Paragraph 1200-3-18-.01(3) contains provisions for standards that limit the pounds of VOCs per gallon of material and rule 1200-3-18-.22 concerns leaks from gasoline tank trucks and vapor collection systems.

- Rule 1200-3-18-.08 Bulk Gasoline Plants;
- Rule 1200-3-18-.09 Bulk Gasoline Terminals; and
- Rule 1200-3-18-.10 Gasoline Service Stations Stage I.

The following rules have been revised to reference the compliance provisions in paragraph 1200-3-18-.01(3).

- Rule 1200-3-18-.12 Can Coating;
- Rule 1200-3-18-.14 Fabric and Vinyl Coating;
- Rule 1200-3-18-.20 Flat Wood Paneling Coating;
- Rule 1200-3-18-.21 Surface Coating of Miscellaneous Metal Parts and Products;
- Rule 1200-3-18-.22 Leaks from Gasoline Tank Trucks and Vapor Collection Systems;
- Rule 1200-3-18-.23 Petroleum Refinery Equipment Leaks;
- Rule 1200-3-18-.25 Petroleum Liquid Storage in External Floating Roof Tanks;
- Rule 1200-3-18-.26 Manufacture of Pneumatic Rubber Tires;
- Rule 1200-3-18-.27 Manufacture of Synthesized Pharmaceutical Products;
- Rule 1200-3-18-.28 Perchloroethylene Dry Cleaning; and
- Rule 1200-3-18-.29 Graphic Arts-Rotogravure and Flexography.

<sup>1</sup> Among other things, the pre-amendment guidance consists of the Post-87 Policy, 52 FR 45044 (November 24, 1987); the Blue Book, "Issues relating to VOC Regulation Cutpoints, Deficiencies, and Deviations, Clarification to Appendix D of November 24, 1987, Federal Register Notice;" and the existing Control Techniques Guidelines (CTGs).

<sup>2</sup> The Memphis and Nashville areas retained the designations of nonattainment and were classified by operation of law pursuant to sections 107(d) and 181 (a) upon enactment of the Amendments. 56 FR 56694 (November 6, 1991).

<sup>3</sup> On February 16, 1990, July 3, 1991, October 4, 1991, and January 2, 1992, the State submitted certain corrections to the VOC RACT rules for Nashville-Davidson County. EPA approved the February 16, 1990; revisions at 56 FR 10171 on March 11, 1991, and the rest of the amendments at 57 FR 28625 on June 26, 1992.

**Rule 1200-3-18-.01 Purpose and General Provisions**

The following changes were made to both the Tennessee and Memphis portions of the SIP.

Paragraph (1) was revised to change the applicability of emission standards and requirements from "new and existing" sources to "certain" sources of VOCs for which applicability is specified in this chapter or other chapters of division 1200-3. This paragraph was also revised to state that "[i]n determining whether the source category at a facility satisfies the applicability standard of a specific rule, the potential emissions from all sources of the source category shall be totaled."

Paragraph (3) was added to describe the standards that limit the pounds of VOCs per gallon of material. These standards must now specify the allowable VOC content per gallon of material less water. Demonstration of compliance with the VOC content standards of chapter 1200-3-18 was also addressed in paragraph (3). This paragraph states that compliance "other than by use of complying materials, shall be demonstrated by the limitation of volatile organic compound emissions to a level equivalent to the quantities which theoretically would be emitted if complying materials would be used."

Paragraph (4) describing methods for proof of compliance with the standards in chapter 1200-3-18 was also added to this rule. EPA is conditionally approving subparagraph 1200-3-18-.01(4)(b) in the Memphis submittal because it provides for determination of the VOC content, water content, densities, volume solids, and weight solids by certification from the manufacturer, if supported by batch formulation records and approved by the Technical Secretary. Based on Attachment 4 to the May 25, 1988, "Blue Book," the reference to batch formulation data must be changed to batch analytical data. In a letter dated January 25, 1994, the State committed for Memphis to correct this deficiency by February 1, 1995. EPA is not approving this revision for the area of Tennessee outside of the Memphis-Shelby county area because the State of Tennessee revised this rule in a subsequent submittal on May 18, 1993, which will be acted on by EPA in a later notice.

Subparagraph 1200-3-18-.01(4)(c), which refers to the procedure for the determination of capture efficiency, was withdrawn by the State via letter dated August 26, 1992, from Mr. John W. Walton, Technical Secretary of the Tennessee Air Pollution Control Board.

Subparagraph 1200-3-18-.01(4)(c) was not included in the Memphis-Shelby County submittal.

Paragraph (5) describing monitoring to confirm continuing compliance and daily recordkeeping procedures was added. Paragraph (6) providing for a nonrenewable exemption from the standards in chapter 1200-3-18 was also added.

**Rule 1200-3-18-.02 Definitions**

The definitions of "urban county," "rural county," and "approved" were deleted. The definitions of "volatile organic compound" and "coating line" were revised to correct deficiencies. Definitions of "exempt solvent," "operation," "potential VOC emissions," "potential emissions," and "legally enforceable" were added. A minor revision was made to the definition of "existing source" to change the word "process(es)" to "process."

**Rule 1200-3-18-.03 Standard for New Sources**

Tennessee proposed to delete this rule in its entirety. EPA is disapproving the deletion of this rule for the Tennessee submittal because Tennessee does not have federally approved New Source Review (NSR) regulations which apply to some of the sources in this chapter. EPA is approving the deletion of this rule for the Memphis submittal because the federally approved Tennessee NSR applies to the Memphis-Shelby County area. Section 110(l) of the CAA provides that EPA shall not approve a SIP revision if the revision interferes with any applicable requirements concerning attainment and reasonable further progress, or any other applicable requirements of the CAA. Section 110(k) of the CAA addresses the situation in which an entire submittal, or a separable portion of a submittal, meets all applicable requirements of the CAA. In the case where a separable portion of the submittal meets all of the applicable requirements, partial approval may be used to approve that part of the submittal and disapprove the remainder. EPA has determined that the proposed deletion of this rule is separable from the submittal because the other revisions apply to existing sources and this proposed revision applies only to new sources.

Tennessee may submit the deletion of this rule with the submittal of their revised NSR regulations. For the deletion to be approvable, the revised NSR regulation must meet the provisions of part D of title I of the CAA, must contain requirements that will apply to the sources under this chapter

and must be at least as stringent as the rule they propose to delete.

**Rule 1200-3-18-.04 Alternate Emission Standard**

This rule was deleted in its entirety. Alternate emission standards for VOCs were added to chapter 1200-3-21.

**Rule 1200-3-18-.05 Automobile and Light Duty Truck Manufacturing**

This rule was deleted in its entirety because there were no sources subject to the rule as contained in the Tennessee SIP and the Memphis portion of the Tennessee SIP. A new regulation for such sources consistent with EPA guidance has been submitted by the State and EPA will act on this submittal in a subsequent document.

**Rule 1200-3-18-.06 Paper Coating**

The definition of "Paper coating" in subparagraph (1)(b) was revised to include "decorative, functional, and protective coatings." Paragraph (2) was revised to make saturation operations subject to the provisions of this rule.

Paragraph (3) was revised to clarify the discharge limitation for the owner or operator of a paper coating line subject to this rule. The limitation disallows "the discharge into the atmosphere of any volatile organic compound in excess of 0.35 kilograms per liter (2.9 pounds per gallon) of coating as applied (or as delivered to the applicator), excluding water and exempt solvents, except as provided in 1200-3-18-.01(3)."

**Rule 1200-3-18-.07 Petroleum Liquid Storage**

The reference to rule 1200-3-18-.41 was deleted in paragraph (4) because the rule was changed and the exemption is no longer applicable.

**Rule 1200-3-18-.08 Bulk Gasoline Plants**

Minor revisions were made to the exemptions in paragraph (3) for purposes of correction and clarification.

**Rule 1200-3-18-.09 Bulk Gasoline Terminals**

A condition was added to the loading restrictions in paragraph (3). This condition states that no person may load gasoline into any tank trucks or trailers from any bulk gasoline terminal unless all loading and vapor lines are equipped with fittings which are vapor-tight.

Paragraph (6) was added to specify the applicable test method for determining VOC emissions from bulk gasoline terminals. This paragraph included subparagraphs which describe the principle, method summary,



applicability, apparatus, test requirements, basic measurements required, test procedure, calculations, and calibrations of the test method.

**Rule 1200-3-18-.10 Gasoline Service Stations Stage I**

The exemptions in paragraph (3) were revised. EPA is conditionally approving the exemption in subparagraph (3)(a) of the Memphis submittal because it provides for director's discretion and therefore is not approvable. The exemption specifies that gasoline dispensing facilities equipped with control devices which have been approved by the Technical Secretary as providing emission reductions equivalent to that provided by floating roofs are exempt from this rule. In a letter dated January 25, 1994, the State committed for Memphis to correct this deficiency by February 1, 1995. EPA is not approving this revision for the area of Tennessee outside of the Memphis-Shelby county area because the State of Tennessee revised this rule in a subsequent submittal on May 18, 1993, which will be acted on by EPA in a later document.

Subparagraph (3)(b) was revised to change the exemption from "stationary gasoline storage containers of less than 7,570 liters (2,000 gallons)" to "stationary gasoline storage containers of less than 2,085 liters (550 gallons) capacity used exclusively in agriculture." Subparagraph (3)(c) was revised to change the exemption to facilities in counties other than Davidson and Shelby Counties. Subparagraph (3)(d) was revised to change the exemption from "gasoline dispensing facilities with an annual throughput of less than 260,000 gallons which is serviced with a tank truck with a capacity of 4,200 gallons or less" to "gasoline dispensing facilities with an annual throughput of less than 120,000 gallons."

Conditions were added to the limitations on the transfer of gasoline described in paragraph (4). These conditions specify that, "[e]xcept as provided under paragraph (3) of this rule, no owner or operator may transfer or cause or allow the transfer of gasoline from any delivery vessel into any stationary storage tank as described in subparagraphs (a) and (b) of this paragraph, unless the tank is equipped with a submerged fill pipe and the vapors displaced from the storage tank during filling are processed by a vapor control system in accordance with paragraph (5) of this rule." Subparagraph (a) specifies "any stationary storage tank located at a gasoline dispensing facility, with a

capacity of 7,580 liters (2,000 gallons) or more, which is in place before January 1, 1979." Subparagraph (b) specifies "any stationary storage tank located at a gasoline dispensing facility, with a capacity of 948 liters (250 gallons) or more, which is installed after December 31, 1978." Minor changes were made to the phrasing in paragraph (6) to clarify the conditions on the owner or operator of a gasoline dispensing facility regarding design, maintenance, and refilling of a vapor-laden delivery vessel.

**Rule 1200-3-18-.11 Petroleum Refinery Sources**

The reference to rule 1200-3-18-.41 was deleted in paragraph (2) because this rule was changed and is no longer applicable.

**Rule 1200-3-18-.12 Can Coating**

Minor revisions were made in subparagraphs (3)(a), (b), (c), and (d) to clarify the limitations on the discharge of VOCs into the atmosphere.

**Rule 1200-3-18-.13 Coil Coating**

This rule was added to chapter 1200-3-18. Paragraph (1) contains definitions of "Coil coating" and "Quench area." Paragraph (2) applies the rule, in accordance with 1200-3-18-.13 (3), to the coating applicator(s), oven(s), and quench area(s) of coil coating lines involved in prime and top coat or single coat operations.

Paragraph (3) disallows the discharge of VOCs from a coil coating line into the atmosphere "in excess of 0.31 kilograms per liter (2.6 pounds per gallon) of prime and topcoat or single coat as applied (or as delivered to the applicator), excluding water and exempt solvents, except as provided in 1200-3-18-.01(3)." In the Memphis submittal, EPA is conditionally approving paragraph (3) because to meet RACT, the emission limits must apply to any coating, not just prime and topcoat or single coat. In a letter dated January 25, 1994, the State committed for Memphis to correct this deficiency by February 1, 1995. EPA is not approving this revision for the area of Tennessee outside of the Memphis-Shelby county area because the State of Tennessee revised this rule in a subsequent submittal on May 18, 1993, which will be acted on by EPA in a later notice.

**Rule 1200-3-18-.14 Fabric and Vinyl Coating**

The definition of "Vinyl coating" in subparagraph (1)(b) was revised to exempt the application of plastisol coatings. The qualification that plastisol coatings cannot be used to bubble

emissions from vinyl printing and topcoating was also added to subparagraph (1)(b).

The applicability provision in paragraph (2) was revised to include saturation operations. Minor revisions were made to the phrasing in subparagraphs (3)(a) and (b) to clarify the VOC emission limitations.

**Rule 1200-3-18-.15 Metal Furniture Coating**

Minor revisions were made to the phrasing in paragraph (3) to clarify the VOC emission limitations.

**Rule 1200-3-18-.16 Surface Coating of Large Appliances**

A minor revision was made in paragraph (3) to correctly reference the VOC emissions limitations in paragraph (4). Minor revisions were made to the phrasing in paragraph (4) to clarify the VOC emission limitations.

**Rule 1200-3-18-.17 Magnet Wire Coating**

Minor revisions were made to the phrasing in paragraph (2) to clarify the VOC emission limitations.

**Rule 1200-3-18-.18 Solvent Metal Cleaning**

The reference to rule 1200-3-18-.41 was deleted in paragraph (2) because this rule was changed and is no longer applicable.

**Rule 1200-3-18-.20 Flat Wood Panelling Coating**

Paragraphs (5) and (6), providing for increments of progress and proof of compliance respectively, were deleted because the dates for demonstration of compliance had expired.

**Rule 1200-3-18-.21 Surface Coating of Miscellaneous Metal Parts and Products**

Definitions of "High performance architectural coating" and "Refinishing" were added to paragraph (1). The definition of "High performance architectural coating" specifies that it is a coating "[a]ppplied at a facility located in a county which is attainment for ozone and had a population of less than 15000 according to the 1980 census." An emission limitation of 0.75 kg/l (6.2 lb/gal) for high performance architectural coating as applied (or as delivered to the applicator), excluding water and exempt solvents, was added as subparagraph (2)(a). The emission limitation of 0.52 kg/l (4.3 lb/gal) for clear coating as applied was clarified and moved from subparagraph (2)(a) to (2)(b). The emission limitation of 0.42 kg/l (3.5 lb/gal) for air dried coating as applied was clarified and moved from

subparagraph (2)(b) to (2)(c). The emission limitation of 0.42 kg/l (3.5 lb/gal) for extreme performance coating as applied was clarified and moved from subparagraph (2)(c) to (2)(d). The emission limitation of 0.36 kg/l (3.0 lb/gal) for all other coating as applied was clarified and moved from subparagraph (2)(d) to (2)(e).

The exemptions for the exterior of marine vessels and for bicycles in subparagraphs (5)(j) and (5)(m) were withdrawn by the State via letter dated March 9, 1993, from Mr. John W. Walton, Technical Secretary of the Tennessee Air Pollution Control Board. On August 30, 1993, the State sent another letter to EPA withdrawing these exemptions from the Memphis submittal. The exemption in subparagraph (5)(1) for prime and top coating aerospace components was deleted. Paragraphs (7) and (8), providing for increments of progress and proof of compliance respectively, were deleted.

#### **Rule 1200-3-18-.22 Leaks From Gasoline Tank Trucks and Vapor Collection Systems**

The limitation in subparagraph (2)(a) on loading and unloading conditions for a gasoline tank truck was further specified by the addition of the phrase "when pressurized to gauge pressure of 4,500 pascals (18 in. of H<sub>2</sub>O)." Paragraph (3) was amended by the addition of the requirement that testing of gasoline tank trucks for leak tightness be accomplished during or before the twelfth month after the month of the last test in which compliance with the standards of (2)(a) was demonstrated.

Paragraph (4) was revised to state that the rule is also applicable to gasoline tank trucks which load or unload at applicable plants, terminals, or gasoline dispensing facilities in Shelby County. The requirement in paragraph (4) that gasoline tank trucks be equipped for gasoline vapor collection for this rule to be applicable was deleted. Paragraph (4) was also reorganized into subparagraphs for clarity.

Paragraph (5) requiring initial testing was deleted. The reference to rule 1200-3-18-.42 was deleted in paragraph (6) because this rule was changed and is no longer applicable.

Subparagraphs (6)(a) and (b) were revised to provide for EPA's approval of equivalent test procedures for proof of compliance.

#### **Rule 1200-3-18-.23 Petroleum Refinery Equipment Leaks**

Subparagraph (2)(a) was revised so that pressure relief devices which are connected to inaccessible valves are no

longer exempt from inclusion in the inspection program. Paragraph (4), providing for the institution of an approved inspection program, was deleted.

#### **Rule 1200-3-18-.25 Petroleum Liquid Storage in External Floating Roof Tanks**

Paragraph (5), providing for increments of progress, was deleted.

#### **Rule 1200-3-18-.26 Manufacture of Pneumatic Rubber Tires**

Paragraphs (5) and (6), providing for increments of progress and proof of compliance respectively, were deleted.

#### **Rule 1200-3-18-.27 Manufacture of Synthesized Pharmaceutical Products**

Paragraphs (4) and (5), providing for increments of progress and proof of compliance respectively, were deleted.

#### **Rule 1200-3-18-.28 Perchloroethylene Dry Cleaning**

Paragraph (5), providing for increments of progress, was deleted. Subparagraph (6)(d), providing for consistency with the test methods and procedures in rule 1200-3-18-.43, was also deleted. The test methods for proof of compliance are now provided for in paragraph 1200-3-18-.01(4).

#### **Rule 1200-3-18-.29 Graphic Arts—Rotogravure and Flexography**

Subparagraph (2)(b) was revised to add the requirement that the ink in flexographic and packaging rotogravure contain no more than 0.5 pound VOC per pound of solids. Subparagraph (2)(b) was also reorganized into subparagraphs for clarity. Paragraphs (5) and (6), providing for increments of progress and proof of compliance respectively, were deleted.

#### **Rule 1200-3-18-.30 Surface Coating of Aerospace Components**

This rule was deleted in its entirety because aerospace sources are subject to Rule 1200-3-18-.21 Surface Coating of Miscellaneous Metal Parts and Products.

#### **Rule 1200-3-18-.40 Regulations Required Only in Metropolitan Davidson County**

This rule was renamed "Regulations Required in Nonattainment Areas." Paragraph (1) was deleted and reserved for future use. Paragraph (2) was completely revised to state that "[a]ny plant within a county designated in Part 1200-3-2-.01(1)(ffff)3 as nonattainment for ozone having sources with potential volatile organic compound emissions totaling more than 100 tons/year in the aggregate shall utilize reasonably available control technology (RACT) for

volatile organic compound emission from those sources." This changes the emission requirement for implementing RACT from 1000 tons/year or greater only in the Metropolitan Davidson county to 100 tons/year or greater in the entire ozone nonattainment area which makes the rule more stringent. The State has submitted further revisions to meet the non-CTG requirements for the Nashville area and these will be addressed in a subsequent action by EPA. EPA is approving this revision for its strengthening effect.

#### **Rule 1200-3-18-.41 Compliance Schedules**

This rule was deleted and replaced with the requirement that the owner or operator of a source in existence or having a State or local agency's construction permit before June 7, 1992, and subject to a standard in chapter 1200-3-18 shall satisfy the applicable increments of progress specified in subparagraphs (a), (b), and (c). This rule also includes a certification requirement and an exemption provision.

#### **Rule 1200-3-18-.42 Individual Compliance Schedules**

Paragraph (1) was revised to state that a facility with a source satisfying the applicability provisions of rule 1200-3-18-.41 may petition for a specific compliance schedule differing from the schedules contained in 1200-3-18-.41 and other rules in chapter 18 only if one or more of the conditions specified in subparagraphs (a) and (b) are satisfied. The condition in subparagraph (1)(c) was deleted.

Paragraph (2) was revised to delete the word "alphabetical," which was a typographical error, and to require final compliance with the specified emission standard as expeditiously as possible, consistent with the limiting conditions specified in paragraph (1) of this rule. Paragraph (3) was revised to state that individual compliance schedules approved under this rule must be submitted to EPA for approval. Paragraph (4) was revised to delete the reference to Hamilton County.

**Rule 1200-3-18-.43 General Provisions for Test Methods and Procedures****Rule 1200-3-18-.44 Determination of Volatile Content of Surface Coatings****Rule 1200-3-18-.45 Test Methods for Determination of Volatile Organic Compound Emissions Control Systems Efficiency****Rule 1200-3-18-.46 Test Method for Determination of Solvent Metal Cleaning Organic Compound Emissions****Rule 1200-3-18-.47 Test Procedure for Determination of VOC Emissions From Bulk Gasoline Terminals**

The above listed rules were deleted in their entirety. The test methods and procedures for proof of compliance are now provided for in paragraph 1200-3-18-.01(4).

**Rule 1200-3-18-.48 Capture Efficiency Test Procedures**

This rule was withdrawn by the State via letter dated August 26, 1992, from Mr. John W. Walton, Technical Secretary of the Tennessee Air Pollution Control Board. On August 30, 1993, the State sent another letter withdrawing this rule from the Memphis submittal.

The State intends to adopt capture efficiency (CE) test procedures after EPA publishes its revised CE test procedures. The study to evaluate the cost and technical aspects of alternative CE methods has been completed. EPA issued a draft document on October 6, 1993. This document is currently undergoing review and comment. Where states have not yet adopted CE regulations, EPA is allowing them to defer adoption of CE test requirements while the study is underway.

**Chapter 1200-3-21 General Alternate Emission Standards****Rule 1200-3-21-.01 General Alternate Emission Standard**

The following changes were made to both the Tennessee and Memphis portions of the SIP.

Paragraph (1) was revised to state that in lieu of satisfying the standards and requirements of other chapters of division 1200-3, air contaminant sources with a certificate of alternate control shall not emit particulate matter, sulfur dioxide, carbon monoxide, nitrogen dioxide, or volatile organic compounds in excess of the respective limits of said certificate.

Paragraph (2) was revised to allow sources of VOCs regulated by other rules in the State's regulations to apply for a Certificate of Alternate Control. Paragraph (2) was also revised to change the word "source" to "source(s)," and to

change the word "must" to "may" with regard to the Technical Secretary granting a request for a Certificate of Alternate Control. In addition, the requirement that these standards and conditions be submitted to EPA for approval was included in paragraph (3).

The condition in subparagraph (2)(a) was revised to include VOCs and to replace the language regarding determination of equivalent emissions. Subparagraph (2)(b) was revised to state that if a schedule of compliance is required, it must be included as a condition on the certificate. The phrase "this date" was changed to "the final compliance date."

Subparagraph (2)(c) was revised to require the air contaminant source to use modeling consistent with *Guideline on Air Quality Models (Revised)*, EPA-450/2-78-027R, with the 1988 revisions, to verify that the alternate emission standard will yield equivalent or improved air quality for the pollutant involved. Minor revisions were also made in subparagraph (2)(c) to correct typographical errors.

Subparagraph (2)(d) was revised to correct the reference to another rule and to replace the word "old" with "existing" in reference to sources. Subparagraph (2)(d) was also revised to require compliance with all applicable standards and requirements established under paragraph 1200-3-9-.01(4), under chapters 1200-3-11 and 16, and according to a lowest achievable emission rate (LAER) determination under paragraph 1200-3-9-.01(5). These standards and requirements will not be superseded or replaced by the alternate emission standard.

Subparagraph (2)(e), providing that sources must establish a specific emission limit for each emission point, was deleted. Subparagraph (2)(f) was renamed (2)(e) and revised to increase the certificate fee for each source.

Subparagraph (2)(g) was renamed (2)(f) and a phrase was deleted for clarification. A new subparagraph, (2)(g) was added to state that the provisions of the Emissions Trading Policy Statement, 51 FR 43850, dated December 4, 1986, are being satisfied. This policy statement is more stringent than subparagraph (2)(e) which was deleted.

Paragraph (3) was revised so that alternate emission standards and certificate conditions are no longer considered to be an addition to the existing standards. In addition, the requirement that these standards and conditions be submitted to EPA for approval was included in paragraph (3).

Paragraph (4) was revised to state that "[g]ood engineering practice stack heights shall be utilized on all stack

changes associated with the alternate control standards for particulate matter, sulfur dioxide, carbon monoxide, and nitrogen dioxide." Paragraph (9) was revised to delete the reference to each emission point.

**Rule 1200-3-21-.02 Applicability**

This rule was added to make chapter 1200-3-21 applicable "only to those air contaminant sources which apply for a certificate of alternate control or a revision to a certificate of alternate control after March 18, 1993."

**Final Action**

EPA is fully approving the submitted revisions to the Tennessee State Implementation Plan (SIP) and the Memphis portion of the Tennessee SIP with the exception of the proposed revisions to Rules 1200-3-18-.01 (subparagraph (4)(b)), 1200-3-18-.10 (subparagraph (3)(a)), and 1200-3-18-13 (paragraph (3)) of the Memphis portion of the Tennessee SIP for which we are issuing a conditional approval and Rule 1200-3-18-.03 Standard for New Sources of the Tennessee SIP for which we are disapproving the proposed deletion.

In addition, EPA is not approving the proposed revisions to rules 1200-3-18-.01 (subparagraph (4)(b)), 1200-3-18-.10 (subparagraph (3)(a)), and 1200-3-18-13 (paragraph (3)) of the Tennessee SIP. These rules were revised in a subsequent submittal by Tennessee on May 18, 1993. Therefore, since these revisions are not approvable as submitted in this action, EPA will act on these rules in the action on the May 18, 1993, submittal.

Because Tennessee has made a commitment for the Memphis nonattainment area that EPA believes meets the requirements necessary for EPA to grant conditional approval, EPA is conditionally approving under section 110(k)(4) of the CAA. In order for EPA to take final action on the commitment, the State must meet their commitment for the Memphis nonattainment area to adopt the identified provisions by February 1, 1995, and submit them to EPA within the time specified in this schedule. If the State fails to adopt or submit these rules for Memphis-Shelby County to EPA within this time frame, this approval will become a disapproval on that date. EPA will notify the area by letter that this action has occurred. At that time, this commitment will no longer be a part of the approved Memphis-Shelby County portion of the Tennessee SIP. EPA subsequently will publish a notice in the notice section of the Federal Register. If Tennessee

adopts and submits these rules for Memphis-Shelby County to EPA within the applicable time frame, the conditionally approved submission will remain a part of the SIP until EPA takes final action approving or disapproving the new submittal. If EPA disapproves the new submittal, the conditionally approved submittal will also be removed from the SIP. Moreover, the rules on which the conditional approval was based will also be disapproved at that time. If EPA approves the submittal, those newly approved rules will become a part of the SIP and will modify or replace the commitment and the rules on which the conditional approval is based.

If EPA determines that it cannot issue a final, conditional approval or if the conditional approval is converted to a disapproval, the sanctions clock under section 179(a) will begin. This clock will begin at the time EPA issues the final disapproval or on the date Tennessee fails to meet its commitment. In the latter case, EPA will notify the area by letter that the conditional approval has been converted to a disapproval and that the sanctions clock has begun. If the State does not submit and EPA does not approve the rule on which the disapproval was based within 18 months of the disapproval, EPA must impose one of the sanctions under section 179(b)—highway funding restrictions or the offset sanction. In addition, the final disapproval triggers the Federal implementation plan (FIP) requirement under section 110(c).

This action is being taken without prior proposal because the changes are noncontroversial and EPA anticipates no significant comments on them. The public should be advised that this action will be effective June 17, 1994. However, if notice is received by May 18, 1994 that someone wished to submit adverse or critical comments, this action will be withdrawn and two subsequent documents will be published before the effective date. One document will withdraw the final action and another will begin a new rulemaking by announcing a proposal of the action and establishing a comment period.

Under section 307(b)(1) of the CAA, 42 U.S.C. 7607 (b)(1), petitions for judicial review of this action must be filed in the United States Court of Appeals for the appropriate circuit by June 17, 1994. Filing a petition for reconsideration by the Administrator of this final rule does not affect the finality of this rule for purposes of judicial review nor does it extend the time within which a petition for judicial review may be filed, and shall not postpone the effectiveness of such rule

or action. This action may not be challenged later in proceedings to enforce its requirements. (see section 307(b)(2) of the CAA, 42 U.S.C. 7607 (b)(2)).

This action has been classified as a Table 2 action by the Regional Administrator under the procedures published in the Federal Register on January 19, 1989 (54 FR 2214-2225), as revised by an October 26, 1993, memorandum from Michael H. Shapiro, Acting Assistant Administrator for Air and Radiation. A future document will inform the general public of these tables. On January 6, 1989, the Office of Management and Budget (OMB) waived Table 2 and 3 SIP revisions (54 FR 2222) from the requirements of section 3 of Executive Order 12291 for two years. The EPA has submitted a request for a permanent waiver for Table 2 and Table 3 SIP revisions. The OMB has agreed to continue the waiver until such time as it rules on EPA's request. This request continues in effect under Executive Order 12866 which superseded Executive Order 12291 on September 30, 1993.

Nothing in this action shall be construed as permitting or allowing or establishing a precedent for any future request for a revision to any SIP. Each request for revision to the SIP shall be considered separately in light of specific technical, economic, and environmental factors and in relation to relevant statutory and regulatory requirements.

Under the Regulatory Flexibility Act, 5 U.S.C. 600 *et seq.*, EPA must prepare a regulatory flexibility analysis assessing the impact of any proposed or final rule on small entities. 5 U.S.C. 603 and 604. Alternatively, EPA may certify that the rule will not have a significant impact on a substantial number of small entities. Small entities include small businesses, small not-for-profit enterprises, and government entities with jurisdiction over populations of less than 50,000.

SIP approvals and conditional approvals under section 110 and subchapter I, part D of the CAA do not create any new requirements, but simply approve requirements that the State is already imposing. Therefore, because the Federal SIP-approval does not impose any new requirements, EPA certifies that it does not have a significant impact on any small entities affected. Moreover, due to the nature of the Federal-state relationship under the CAA, preparation of a regulatory flexibility analysis would constitute Federal inquiry into the economic reasonableness of State action. The CAA forbids EPA to base its actions concerning SIPs on such grounds.

*Union Electric Co. v. U.S. EPA*, 427 U.S. 246, 256-66 (S. Ct. 1976); 42 U.S.C. 7410(a)(2).

#### List of Subjects in 40 CFR Part 52

Environmental protection, Air pollution control, Carbon monoxide, Hydrocarbons, Incorporation by reference, Intergovernmental relations, Nitrogen dioxide, Ozone, Particulate matter, Reporting and recordkeeping requirements, Sulfur dioxide, Volatile organic compounds.

Dated: March 22, 1994.

Patrick M. Tobin,

Acting Regional Administrator.

Part 52, chapter I, title 40 of the Code of Federal Regulations, is amended as follows:

#### PART 52—[AMENDED]

1. The authority citation for part 52 continues to read as follows:

Authority: 42 U.S.C. 7401-7671q.

#### Subpart RR—Tennessee

2. Section 52.2219 is added to subpart RR to read as follows:

##### § 52.2219 Identification of plan—conditional approval.

EPA is conditionally approving the following revisions to the Memphis-Shelby County portion of the Tennessee SIP contingent on Memphis meeting the schedule which was committed to for Memphis by Tennessee in a letter dated December 20, 1993, and amended on January 25, 1994, from the State of Tennessee to EPA Region IV.

(a) Rule 1200-3-18-.01 Purpose and General Provisions: Subparagraph (4)(b) effective October 23, 1993.

(b) Rule 1200-3-18-.10 Gasoline Service Stations Stage I: Subparagraph (3)(a) effective October 23, 1993.

(c) Rule 1200-3-18-.13 Coil Coating: Paragraph (3) effective October 23, 1993.

3. Section 52.2220 is amended by adding paragraph (c)(115) to read as follows:

##### § 52.2220 Identification of plan.

\* \* \* \* \*

(c) \* \* \*

(115) Revisions to the rules in the State's portion of the Tennessee State Implementation Plan (SIP) regarding control of volatile organic compounds (VOCs) were submitted on June 25, 1992, and March 22, 1993, by the Tennessee Department of Environment and Conservation. Revisions to the rules in the Memphis-Shelby County portion of the Tennessee SIP regarding control of VOCs were submitted on November 5, 1992, and April 22, 1993, by the State

on behalf of Memphis-Shelby County. In these submittals, Memphis-Shelby County adopted State regulations by reference.

(i) Incorporation by reference.

(A) Revisions to the following State of Tennessee regulations were effective on June 7, 1992.

(1) Rule 1200-3-2-.01 General Definitions: Subparagraphs (1)(b), (c), (z), (aa), (gg), (vv), (zz), (ccc), (lll), (mmm), (nnn), (eee), (fff), (ggg), and (iiii).

(2) Rule 1200-3-18-.01 Purposes and General Provisions: Paragraphs (1), (3), (4) introductory paragraph and (4)(a), (5), and (6).

(3) Rule 1200-3-18-.02 Definitions: Subparagraphs (1)(a), (b), (c), (f), (m), (ii), and (jj).

(4) Rule 1200-3-18-.04 Alternate Emission Standard.

(5) Rule 1200-3-18-.05 Automobile and Light Duty Truck Manufacturing.

(6) Rule 1200-3-18-.06 Paper Coating: Subparagraph (1)(b) and paragraphs (2), (3), and (4).

(7) Rule 1200-3-18-.07 Petroleum Liquid Storage: Introductory paragraph of paragraph (4).

(8) Rule 1200-3-18-.08 Bulk Gasoline Plants: Paragraphs (2) and (3).

(9) Rule 1200-3-18-.09 Bulk Gasoline Plants: Paragraph (2), subparagraph (3)(d), and paragraph (6).

(10) Rule 1200-3-18-.10 Gasoline Service Stations Stage I: Paragraphs (2), (3) (except subparagraph (3)(a)), (4), and (6).

(11) Rule 1200-3-18-.11 Petroleum Refinery Sources: Paragraph (2).

(12) Rule 1200-3-18-.12 Can Coating: Paragraphs (3) and (4).

(13) Rule 1200-3-18-.13 Coil Coating: Paragraphs (1), (2), and (4).

(14) Rule 1200-3-18-.14 Fabric and Vinyl Coating: Subparagraph (1)(b) and paragraphs (2), (3), and (4).

(15) Rule 1200-3-18-.15 Metal Furniture Coating: Paragraphs (3) and (4).

(16) Rule 1200-3-18-.16 Surface Coating of Large Appliances: Paragraphs (3), (4), and (5).

(17) Rule 1200-3-18-.17 Magnet Wire Coating: Paragraphs (2) and (3).

(18) Rule 1200-3-18-.18 Solvent Metal Cleaning: Paragraphs (2) and (3).

(19) Rule 1200-3-18-.20 Flat Wood Paneling Coating: Introductory paragraph of paragraph (2), paragraphs (4), (5), and (6).

(20) Rule 1200-3-18-.21 Surface Coating of Miscellaneous Metal Parts and Products: Subparagraphs (1)(g) and (h), paragraph (2), subparagraph (5)(1), and paragraphs (6), (7), and (8).

(21) Rule 1200-3-18-.22 Leaks from Gasoline Tank Trucks and Vapor

Collection Systems: Introductory paragraph of paragraph (2), subparagraph (2)(a), paragraphs (3), (4), (5), and (6).

(22) Rule 1200-3-18-.23 Petroleum Refinery Equipment Leaks: Introductory paragraph of paragraph (2), subparagraph (2)(a), and paragraph (4).

(23) Rule 1200-3-18-.25 Petroleum Liquid Storage in External Floating Roof Tanks: Introductory paragraph of paragraph (2), and paragraph (5).

(24) Rule 1200-3-18-.26 Manufacture of Pneumatic Rubber Tires: Introductory paragraph of paragraph (2), paragraphs (4), (5), and (6).

(25) Rule 1200-3-18-.27 Manufacture of Synthesized Pharmaceutical Products: Introductory paragraph of paragraph (2), paragraphs (3), (4), and (5).

(26) Rule 1200-3-18-.28 Perchloroethylene Dry Cleaning: Introductory paragraph of paragraph (2), paragraphs (4) and (5), and subparagraph (6)(d).

(27) Rule 1200-3-18-.29 Graphic Arts—Rotogravure and Flexography: Introductory paragraph of paragraph (2), subparagraph (2)(b), paragraphs (5) and (6).

(28) Rule 1200-3-18-.30 Surface Coating of Aerospace Components.

(29) Rule 1200-3-18-.40 Regulations Required in Nonattainment Areas.

(30) Rule 1200-3-18-.41 Compliance Schedules.

(31) Rule 1200-3-18-.42 Individual Compliance Schedules: Paragraphs (1), (2), (3), and (4).

(32) Rule 1200-3-18-.43 General Provisions for Test Methods and Procedures.

(33) Rule 1200-3-18-.44 Determination of Volatile Content of Surface Coatings.

(34) Rule 1200-3-18-.45 Test Method for Determination of Volatile Organic Compound Emissions Control Systems Efficiency.

(35) Rule 1200-3-18-.46 Test Method for Determination of Solvent Metal Cleaning Organic Compound Emissions.

(36) Rule 1200-3-18-.47 Test Procedure for Determination of VOC Emissions from Bulk Gasoline Terminals.

(B) Revisions to the following State of Tennessee regulations were effective on March 18, 1993.

(1) Rule 1200-3-21-.01 General Alternate Emission Standard: Paragraphs (1), (2), (3), (4), and (9).

(2) Rule 1200-3-21-.02 Applicability.

(ii) Additional material—none.

4. Section 52.2225 is amended by redesignating paragraph (b) as paragraph (c) and adding a new paragraph (b) to read as follows:

**§ 52.2225 VOC rule deficiency correction.**

\* \* \* \* \*

(b) Revisions to sections 1200-3-2 "Definitions", 1200-3-18 "Volatile Organic Compounds" and 1200-3-21 "General Alternate Emission Standards" of the Tennessee SIP and the Memphis portion of the Tennessee SIP were submitted to correct deficiencies pursuant to the SIP call letter for ozone from Greer Tidwell, the EPA Regional Administrator, to Governor McWhorter on May 26, 1988, and clarified in a letter dated June 10, 1988, from Winston Smith, Air, Pesticides & Toxics Management Division Director, to Harold Hodges, Director of the Tennessee Division of Air Pollution. These revisions are approved with the exception of the following which remain as deficiencies and must be corrected by Tennessee and Memphis and the deletion of section 1200-3-18-.03 "Standard for New Sources" in the Tennessee SIP which was disapproved. The deficiencies are common to both Tennessee and Memphis because Memphis adopts the Tennessee regulations by reference.

(1) Rule 1200-3-18-.01 subparagraph (4)(b) must be changed to provide for EPA Administrator approval and the reference to batch formulation data must be changed to batch analytical data.

(2) Rule 1200-3-18-.10 subparagraph (3)(a) must be changed to provide for EPA Administrator approval.

(3) Rule 1200-3-18-.13 paragraph (3) must be changed to apply to any coating, not just prime and topcoat or single coat for this rule to meet the RACT emission limits.

\* \* \* \* \*

5. Section 52.2228 is amended by adding paragraph (e) to read as follows:

**§ 52.2228 Review of new sources and modifications.**

\* \* \* \* \*

(e) The State of Tennessee proposed to delete section 1200-3-18-.03 "Standard for New Sources" from the Tennessee State Implementation Plan (SIP) and the Memphis-Shelby County portion of the Tennessee SIP. EPA is disapproving the deletion of this rule for the Tennessee SIP because Tennessee does not have federally approved New Source Review (NSR) regulations which apply to some of the sources in this chapter. EPA is approving the deletion of this rule for the Memphis submittal because the federally approved TN NSR applies to the Memphis-Shelby County area.

[FR Doc. 94-8969 Filed 4-15-94; 8:45 am]  
BILLING CODE 6560-50-F

## DEPARTMENT OF HEALTH AND HUMAN SERVICES

## Health Care Financing Administration

## 42 CFR Part 405

## Medicare Program; Review of Information Collection and Recordkeeping Requirements for Providers of Outpatient Physical Therapy and/or Speech Pathology

## CFR Correction

In Title 42 of the Code of Federal Regulations, parts 400 to 429, revised as of October 1, 1993, on page 104, the introductory text of § 405.1720 should read as follows:

## § 405.1720 Condition of participation—rehabilitation program.

At a minimum, a rehabilitation agency provides physical therapy or speech pathology services, and a rehabilitation program that in addition to physical therapy or speech pathology services, includes social or vocational adjustment services by making provision for special, qualified staff to evaluate the social or vocational factors involved in a patient's rehabilitation, to counsel and advise on social or vocational problems arising from the patient's illness or injury, and to make appropriate referrals for required services. When hospitals, skilled nursing facilities, or Medicaid nursing facilities obtain services for their patients from the agency this requirement does not apply to those patients.

\* \* \* \* \*

BILLING CODE 1505-01-0

## FEDERAL COMMUNICATIONS COMMISSION

## 47 CFR Part 64

[CC Docket No. 91-281; FCC 94-59]

## Calling Number Identification

AGENCY: Federal Communications Commission.

ACTION: Final rule.

**SUMMARY:** On March 8, 1994, the Commission adopted a Report and Order (R&O) and Further Notice of Proposed Rulemaking (FNPM) in CC Docket 91-281. The R&O amends the rules regarding common carriers to establish federal policies and rules concerning interstate calling number identification service (caller ID). The R&O finds that a federal model for interstate delivery of calling party numbers is in the public interest, that

calling party privacy must be protected, and that certain state regulation of interstate calling party number (CPN) based services, including interstate caller ID, must be preempted.

EFFECTIVE DATE: April 12, 1995.

**FOR FURTHER INFORMATION CONTACT:** Suzanne Hutchings, Domestic Services Branch, Domestic Facilities Division, (202) 634-1802, or Olga Madruga-Forti, Chief, Domestic Services Branch, Domestic Facilities Division, (202) 634-1816.

**SUPPLEMENTARY INFORMATION:** This summarizes the Commission's R&O in the matter of Policies and Rules Concerning Calling Number Identification Service—Caller ID (CC Docket 91-281, FCC 94-59, adopted March 8, 1994 and released March 29, 1994). The R&O and supporting file may be examined in the Commission's Public Reference Room, room 239, 1919 M Street, NW., Washington, DC, during business hours or purchased from the duplicating contractor, International Transcription Service, 2100 M Street, NW., suite 140, Washington, DC 20037, (202) 857-3800. The R&O also will be published in the FCC Record.

## Analysis of Proceeding

This proceeding was initiated by the Commission's Notice of Proposed Rulemaking (NPRM) in CC Docket 91-281, FCC 91-300, 6 FCC Rcd 6752 (1991), (56 FR 57300, November 8, 1991), to establish federal policies and rules governing calling number identification service on an interstate basis.

In its NPRM, the Commission tentatively concluded that a federal model for interstate caller ID should be established; that the federal model should recognize privacy interests of both the called and the calling party; that it should do so efficiently and without interfering with other services (such as 911); that the costs of the service should be recovered from the beneficiaries, the users of the service; and that carriers should pass on the calling party number from the originating carrier to the terminating carriers. The Commission tentatively concluded that it was not necessary to propose to preempt any intrastate caller ID offerings. After reviewing the comments and/or reply comments submitted by interested parties, the Commission has adopted rules which require common carriers using Common Channel Signalling System 7 (SS7) and subscribing to or offering any service based on SS7 functionality must transmit calling party number and its associated privacy indicator on

interstate calls. The rules require that carriers offering CPN based service provided automatic per call blocking at no charge to interstate callers, and that the privacy indicator be honored by terminating carriers. The Report and Order finds that the costs of interstate transmission of CPN are *de minimis*, and that the CPN should be transmitted among carriers without additional charge. The rules require that carriers participating in the offering of any service that delivers CPN on interstate calls must inform telephone subscribers regarding the availability of identification services and how to invoke the privacy protection mechanism. The rules restrict the reuse or sale of telephone numbers by subscribers to automatic number identification (ANI) or charge number services, absent affirmative subscriber consent. The rules are made a part of this publication.

## Request for Comments

The Commission affirmed the tentative conclusion reached in the NPRM that deployment of interstate calling party number services should be accompanied by consumer education regarding the availability of identification services and how to invoke the privacy protection mechanism. For ANI or charge number services for which such privacy is not provided, the rules require that the notification inform telephone customers of the restrictions on the reuse or sale of subscriber information. The Commission seeks further comment on whether it should prescribe detailed instructions regarding what form education should take or prescribe more precisely responsibilities of various carriers. The Commission is also particularly interested in specific joint industry education proposals. The Commission tentatively concludes that its policies for calling party number delivery should apply equally to services delivering calling party name, and seeks comment on its tentative conclusion. The Commission also seeks comment on whether the policies for subscriber privacy should extend to other services. All proposals and other comments must reference CC Docket No. 91-281. In particular, parties should address any differences in privacy considerations that apply to calling party name delivery as opposed to calling party number delivery.

## Final Regulatory Flexibility Analysis

Pursuant to the Regulatory Flexibility Act of 1980, 5 U.S.C. section 601, *et seq.*, the Commission's final analysis in this Report and Order is as follows:

### I. Need and Purpose of This Action

This Report and Order adopts policies governing the transmission of the calling party number parameter and its associated privacy indicator on interstate calls. Several commenters to the NPRM in this proceeding have identified a number of potential uses for interstate calling party number based services, including caller ID, and have indicated that it also will improve certain existing communication service offerings. We find that the potential benefits of interstate passage of calling party number far exceed any negative effects. We thus adopt the conclusion reached in the NPRM that interstate caller ID and other calling party number based services are in the public interest and should be available to interstate subscribers nationwide pursuant to the policies and rules set forth in this order.

### II. Summary of Issues Raised by the Public Comments in Response to the Initial Regulatory Flexibility Analysis

No comments were submitted in direct response to the Initial Regulatory Flexibility Analysis.

### III. Significant Alternatives Considered

The Notice of Proposed Rulemaking in this proceeding requested comments on several proposals as well as the views of commenters on other possibilities. The Commission has considered all comments and has proposed regulations which require the passage of calling party number where SS7 is deployed, facilitate interstate calling party number based services, including caller ID, and implement federal policy on privacy.

#### Ordering Clauses

Accordingly, It is Ordered, That, pursuant to sections 1, 4(i), 4(j), 201-205, 218 of the Communications Act of 1934, as amended, 47 U.S.C. Sections 151, 154(i), 154(j), 201-205, and 218, Part 64 of the Commission's Rules and Regulations are amended as set forth below, effective April 12, 1995.

It is Further Ordered, that pursuant to authority contained in sections 1, 4(i), 4(j), 201-205, and 218 of the Communications Act of 1934, as amended, 47 U.S.C. sections 151, 154(i), 154(j), 201-205, and 218, Further Notice of Proposed Rulemaking<sup>1</sup> is hereby provided as indicated above.

It is Further Ordered, that, the Secretary shall cause a summary of this Report and Order and Further Notice of Proposed Rulemaking to be published in

the **Federal Register** which shall include a statement describing how members of the public may obtain the complete text of this Commission decision. The Secretary shall also provide a copy of this Report and Order and Further Notice of Proposed Rulemaking to each state utility commission.

#### List of Subjects in 47 CFR Part 64

Communications common carriers.

#### Amended Rules

Part 64 of Chapter I of Title 47 of the Code of Federal Regulations is amended as follows:

#### PART 64—MISCELLANEOUS RULES RELATING TO COMMON CARRIERS

1. The authority citation for part 64 continues to read as follows:

**Authority:** Section 4, 48 Stat. 1066, as amended; 47 U.S.C. 154, unless otherwise noted. Interpret or apply secs. 201, 218, 225, 226, 227, 48 Stat. 1070, as amended, 1077; 47 U.S.C. 201, 218, 225, 226, 227, unless otherwise noted.

2. Part 64 is amended by adding a new subpart P to read as follows:

#### Subpart P—Calling Party Telephone Number; Privacy

§ 64.1600 Definitions.

§ 64.1601 Delivery requirements and privacy restrictions.

§ 64.1602 Restrictions on use and sale of telephone subscriber information provided pursuant to automatic number identification or charge number services.

§ 64.1603 Customer notification.

§ 64.1604 Effective date.

#### § 64.1600 Definitions.

(a) **Aggregate Information.** The term 'aggregate information' means collective data that relate to a group or category of services or customers, from which individual customer identities or characteristics have been removed.

(b) **ANI.** The term 'ANI' (automatic number identification) refers to the delivery of the calling party's billing number by a local exchange carrier to any interconnecting carrier for billing or routing purposes, and to the subsequent delivery of such number to end users.

(c) **Calling Party Number.** The term Calling Party Number refers to the subscriber line number or the directory number contained in the calling party number parameter of the call set-up message associated with an interstate call on a Signalling System 7 network.

(d) **Charge Number.** The term "charge number" refers to the delivery of the calling party's billing number in a Signalling System 7 environment by a local exchange carrier to any interconnecting carrier for billing or

routing purposes, and to the subsequent delivery of such number to end users.

(e) **Privacy Indicator.** The term Privacy Indicator refers to information, contained in the calling party number parameter of the call set-up message associated with an interstate call on a Signalling System 7 network, that indicates whether the calling party authorizes presentation of the calling party number to the called party.

(f) **Signalling System 7.** The term Signalling System 7 (SS7) refers to a carrier to carrier out-of-band signalling network used for call routing, billing and management.

#### § 64.1601 Delivery requirements and privacy restrictions.

(a) **Delivery.** Common carriers using Signalling System 7 and offering or subscribing to any service based on Signalling System 7 functionality are required to transmit the calling party number associated with an interstate call to interconnecting carriers.

(b) **Privacy.** Originating carriers using Signalling System 7 and offering or subscribing to any service based on Signalling System 7 functionality will only recognize \*67 dialed as the first three digits of a call (or 1167 for rotary or pulse-dialing phones) as a caller's request for privacy on an interstate call. No common carrier subscribing to or offering any service that delivers calling party number may override the privacy indicator associated with an interstate call. The terminating carrier must act in accordance with the privacy indicator unless the call is made to a called party that subscribes to an ANI or charge number based service and the call is paid for by the called party.

(c) **Charges.** No common carrier subscribing to or offering any service that delivers calling party number may:

(1) Impose on the calling party charges associated with per call blocking of the calling party's telephone number, or

(2) Impose charges upon connecting carriers for the delivery of the calling party number parameter or its associated privacy indicator.

(d) **Exemptions.** Section 64.1601 shall not apply to calling party number delivery services:

(1) Used solely in connection with calls within the same limited system, including (but not limited to) a Centrex, virtual private network, or private branch exchange system;

(2) Used on a public agency's emergency telephone line or in conjunction with 911 emergency services, or on any entity's emergency assistance poison control telephone line; or

<sup>1</sup> The further notice of proposed rulemaking is published elsewhere in this issue of the **Federal Register**.

(3) Provided in connection with legally authorized call tracing or trapping procedures specifically requested by a law enforcement agency.

**§ 64.1602 Restrictions on use and sale of telephone subscriber information provided pursuant to automatic number identification or charge number services.**

(a) Any common carrier providing Automatic Number Identification or charge number services on interstate calls to any person shall provide such services under a contract or tariff containing telephone subscriber information requirements that comply with this subpart. Such requirements shall:

(1) Permit such person to use the telephone number and billing information for billing and collection, routing, screening, and completion of the originating telephone subscriber's call or transaction, or for services directly related to the originating telephone subscriber's call or transaction;

(2) Prohibit such person from reusing or selling the telephone number or billing information without first: (i) Notifying the originating telephone subscriber and

(ii) Obtaining the affirmative consent of such subscriber for such reuse or sale; and

(3) Prohibit such person from disclosing, except as permitted by paragraphs (a) (1) and (2) of this section, any information derived from the automatic number identification or charge number service for any purpose other than:

(i) Performing the services or transactions that are the subject of the originating telephone subscriber's call,

(ii) Ensuring network performance security, and the effectiveness of call delivery,

(iii) Compiling, using, and disclosing aggregate information, and

(iv) Complying with applicable law or legal process.

(b) The requirements imposed under paragraph (a) shall not prevent a person to whom automatic number identification or charge number services are provided from using the telephone number and billing information provided pursuant to such service, and any information derived from the automatic number identification or charge number service, or from the analysis of the characteristics of a telecommunications transmission, to offer a product or service that is directly related to the products or services previously acquired by that customer from such person. Use of such information is subject to the

requirements of 47 CFR 64.1200 and 64.1504(c).

**§ 64.1603 Customer notification.**

Any common carrier participating in the offering of services providing calling party number, ANI, or charge number on interstate calls must notify its subscribers, individually or in conjunction with other carriers, that their telephone numbers may be identified to a called party. Such notification must be made not later than April 12, 1995, and at such times thereafter as to ensure notice to subscribers. The notification shall inform subscribers how to maintain privacy by dialing \*67 (or 1167 for rotary or pulse-dialing phones) on interstate calls. For ANI or charge number services for which such privacy is not provided, the notification shall inform subscribers of the restrictions on the reuse or sale of subscriber information.

**§ 64.1604 Effective date.**

The provisions of §§ 64.1601 through 64.1603 shall be effective as of April 12, 1995.

Federal Communications Commission.

**William F. Caton,**

*Acting Secretary.*

[FR Doc. 94-9358 Filed 4-15-94; 8:45 am]

BILLING CODE 6712-01-M

**DEPARTMENT OF TRANSPORTATION**

**National Highway Traffic Safety Administration**

**49 CFR Part 571**

[Docket No. 91-21; Notice 3]

RIN 2127-AE76

**Federal Motor Vehicle Safety Standards; Air Brake Systems; Automatic Brake Adjusters**

**AGENCY:** National Highway Traffic Safety Administration (NHTSA), Department of Transportation (DOT).

**ACTION:** Final rule, response to petitions for reconsideration.

**SUMMARY:** This notice responds to petitions for reconsideration of a final rule amending Standard No. 121, *Air Brake Systems*, (49 CFR 571.121). The rule amended the standard by requiring, *inter alia*, automatic brake adjusters on all medium and heavy vehicles and establishing readjustment limits for the performance of the adjusters. NHTSA received several petitions requesting the agency to reconsider the limits on the adjusters. This document grants those petitions.

**DATES: Effective Date:** The amendment to § 571.121 becomes effective October 20, 1994.

**Petitions for reconsideration:** Any petitions for reconsideration of this rule must be received by NHTSA no later than May 18, 1994.

**ADDRESSES:** Any petition for reconsideration should refer to the docket and notice number set forth in the heading of this notice and be submitted to: Administrator, NHTSA, 400 Seventh Street SW., Washington, DC 20590.

**FOR FURTHER INFORMATION CONTACT:** Richard C. Carter, Crash Avoidance Division, National Highway Traffic Safety Administration, 400 Seventh Street SW., Washington, DC 20590 (202-366-5274).

**SUPPLEMENTARY INFORMATION:** On October 20, 1992, NHTSA published a final rule that amended Federal Motor Vehicle Safety Standard No. 121, *Air Brake Systems*, to require, *inter alia*, automatic brake adjusters on all air-braked vehicles. (57 FR 47793.) That amendment improves the braking performance of vehicles by ensuring that each vehicle has a device that automatically maintains proper brake adjustment, thus eliminating the need for frequent inspection and manual adjustment of the brakes. To provide for a specific performance requirement for the adjusters, the rule also specified that the adjuster would have to perform such that "the readjustment limits shall be in accordance with those specified in" a regulation of the Federal Highway Administration (FHWA).<sup>1</sup> (See, S5.1.8(a) of Standard No. 121.) The readjustment limits relate to the distance that a part of the brake (the pushrod) must travel, or stroke, before engaging the brake. The readjustment limits specify maximum distances for pushrod stroke.

NHTSA received timely petitions for reconsideration of the rule from Rockwell International (Rockwell) and White GM/Volvo. Petitioners asked for reconsideration of the requirements for the readjustment limits for the adjuster. Mr. John Kourik submitted a late petition to reconsider various aspects of the rule, including the readjustment limits. NHTSA is treating Mr. Kourik's petition as a petition for rulemaking, pursuant to the agency's regulations (see 49 CFR 553.35). However, NHTSA is responding in today's document to the issues raised by Mr. Kourik about the readjustment limits, since they are

<sup>1</sup> Appendix G to subchapter B of Chapter III— "Minimum Periodic Inspection Standards," 49 CFR parts 200 to 399.



almost identical to those of Rockwell and White GM/Volvo.

Each petitioner was concerned about the readjustment limit. Among the petitioners' criticisms were that the requirement is not objective, is inappropriate for certain air brake systems, and is likely to restrict new brake designs. Petitioners also believed that NHTSA did not provide adequate notice about the specification in the final rule for the FHWA readjustment limits.

The concern about the adequacy of notice resulted from the development of the requirement from the original proposal in the NPRM. In the NPRM, NHTSA proposed that a brake adjuster perform so that it "maintains brake adjustment within the manufacturer's recommended adjustment limits." 56 FR 20396, 20401, May 3, 1991. Several commenters, including White GM/Volvo, GM, Ford, and Midland-Grau, believed that the proposal would not provide any significant safety benefits and might cause unnecessary complications and confusion. For example, some commenters argued that, since there is no objective criteria as to what constitutes "maintains brake adjustment," the requirement would be vague. Also, White GM/Volvo, GM and Ford believed that the proposal might be misinterpreted as requiring the manufacturer to be responsible for brake adjustment throughout the vehicle's life, even though under the National Traffic and Motor Vehicle Safety Act the manufacturer is responsible for the compliance of the new vehicle only until the first consumer purchase. One commenter, Midland-Grau, recommended that NHTSA incorporate the FHWA's requirements for brake adjustment, set forth in the Minimum Periodic Inspection Standards.

After reviewing the comments, NHTSA agreed that the proposed requirement for readjustment limits was potentially vague and misleading. However, NHTSA believed Midland-Grau's recommendation about the FHWA alternative had merit. NHTSA stated:

As for Midland-Grau's recommendation to use FHWA's regulations for "Driver Out-of-Service Criteria" for brake adjustment, NHTSA has decided to reference these provisions in Standard No. 121 because they are relevant to in-use heavy truck operation regulated by FHWA. Because amendments to Standard No. 121 require the use of brake adjustment indicators which require the display of underadjustment, a reference to adjustment limits is necessary.

57 FR at 47796.

### Petitions for Reconsideration

All the petitioners raised identical concerns about the incorporation of the FHWA requirements.

#### 1. Design Specific Requirements

Rockwell stated that the FHWA adjustment criteria that NHTSA incorporated would eliminate most air disc brakes from the market. The petitioner said that until 1988, FHWA's readjustment limits for the brake adjuster were in the form of guidelines. These guidelines provided separate requirements for air disc brakes, recognizing that air disc brakes need a slightly longer maximum stroke limit for each chamber size than that specified for drum brakes. For example, Rockwell said, for a type 30 chamber, the old FHWA "minimum criteria" provided for a maximum stroke of 2 inches for drum brakes and 2¼ inches for air disc brakes.

Rockwell stated there are fundamental differences between air disc brakes and drum brakes that account for why the FHWA guidelines permitted air disc brakes to have a slightly longer pushrod stroke limit than drum brakes. The petitioner explained:

In both types of systems, the pushrod stroke length is proportionate to the clearance between the brake lining and the rubbing surface (the drum or the disc). On drum brakes, the clearance and therefore the pushrod stroke gets longer as the brakes become hot and the circular drum wall expands in diameter by as much as one-eighth inch at 800 degrees F. By contrast, a disc brake pushrod stroke gets shorter as the brake gets hotter, because the expansion of the hot rotor brings it closer to the pads which are also expanding in the direction of the rotors.

Rockwell said that when FHWA adopted its rule for readjustment limits (53 FR 49402, December 7, 1988), the rule did not continue to provide separate specifications for air disc brakes, as it had previously done in its guidelines. Rockwell argued that "by omitting the separate table for disc brakes, and requiring drum brakes and air disc brakes to meet the same adjustment criteria, the FHWA Final Rule had the effect of imposing a more stringent requirement on the air disc brakes than it imposed on drum brakes."

Rockwell said that it has asked FHWA to reconsider the agency's 1988 rule and that FHWA has agreed to reopen Docket MC-90-7 for additional comment on the issue of the appropriate requirements for air disc brakes. FHWA anticipates that a notice will be issued in the near future.

Rockwell stated that the effect of incorporating the FHWA readjustment limits would be to prohibit future sales of the air disc brake in certain applications. The petitioner argued that this would be anomalous in view of what Rockwell believes is an excellent safety record for the air disc brake system. Rockwell said that the system has been in use on the road for over 10 years, and,

[S]ince 1985, Rockwell has been the sole North American manufacturer of air disc brakes. Many using customers have purposefully selected the air disc brake because of its unique performance features. High performance requirements of fire service vehicles, frequent braking requirements of refuse vehicles and minimal brake fade requirements desired by tractor/trailer operators hauling hazardous and flammable cargos are typical air disc brake applications.

The National Transportation Safety Board in their April 1992 Heavy Vehicle Airbrake Performance Safety Study noted:

Air disc brakes have several advantages over drum brakes. When subjected to intense braking demands, disc brakes do not suffer the same performance degradations as do drum brakes. Disc brakes also reduce down hill runaways as well as brake imbalances caused by varied brake adjustments on the same vehicle.

#### 2. Design Restrictions

The petitioners raised concerns that the incorporation of the FHWA requirements could hinder technological development, such as that of long stroke brake chambers. (On August 2, 1993, NHTSA published an NPRM to facilitate the use of long stroke brake chambers. 58 FR 41078). Rockwell stated:

By referencing the FHWA readjustment criteria in FMVSS 121, NHTSA has "frozen" the FHWA criteria in their current form as of October 20, 1992, for purposes of FMVSS 121. Even if FHWA later amends its criteria in response to Rockwell's petition or to accommodate new technology, NHTSA will have to take affirmative action to update its cross-reference. \* \* \* The time consuming process of adopting future changes to FMVSS 121 will deter air brake technology or, at least, prevent its rapid introduction into the marketplace. Rockwell believes that NHTSA did not intend this result.

#### Agency's Decision

After reviewing the petitions, NHTSA has decided to delete reference to the FHWA's regulations at issue. It appears that the FHWA readjustment limits are suitable for conventional drum brakes, but do not account for differences between conventional drum brakes and new types of air brake systems. When the agency adopted the readjustment

limits, NHTSA did not intend to impede the development of brake systems that could provide comparable performance to conventional drum brakes, such as piston-type brakes. The FHWA requirements appear to be not fully appropriate for piston-type brakes because of substantially longer stroke length air brake chambers, which are fully developed and are undergoing fleet testing. Additional air brake chamber categories will have to be added to the FHWA Schedule A inspection tables as technology moves forward. Moreover, when NHTSA adopted the readjustment limits, the agency did not intend to prevent or hinder the development of brake designs that may offer *potentially* superior performance over drum brakes in specific applications, such as the air disc brake system.

The air disc brake system is subject to the same readjustment limits in the FHWA requirements as conventional drum brakes, which does not seem appropriate, given differences between the two types of air brake systems. Rockwell's air disc brake system has a stroking distance that is about 1/4 inch longer than that permitted by the current FHWA requirement. However, Rockwell submitted test data to NHTSA that show that, with this stroking distance, the air disc brake system performs well when tested to the specifications and requirements of Standard No. 121. (These data have been placed in docket 91-21, Notice 3.)

Available information indicates that the air disc brake system appears to perform to Standard 121 specifications and may perform better than conventional drum brakes in some situations. There does not appear to be any data to support the need to impose a shorter stroke limit on air disc brake systems such as Rockwell's, that would impede the development of those systems. NHTSA believes the development of alternative, potentially superior brake systems, such as the air disc brake systems, should be facilitated to the extent possible. NHTSA believes there is an alternative requirement that would address the need for readjustment limits, yet avoid the problems the petitioners addressed.

#### Alternative Approach

Rockwell recommended that NHTSA require that the automatic adjuster's readjustment limits "be in accordance with the manufacturer's recommended limits." It commented that this language would be sufficiently objective because NHTSA could confirm the compliance of a brake system by comparing the actual readjustment limits of a brake system with those recommended by the

manufacturer. These manufacturer recommendations are routinely provided by the manufacturer with each vehicle. The petitioner stated that NHTSA has taken this approach in other circumstances, such as with respect to testing safety belts for permissible levels of slack. (See, Standard No. 208, section S7.4.2.)

The agency adopted the FHWA readjustment limits to provide a clear means of determining whether a brake adjuster was performing properly. However, as explained above, the agency now believes that the FHWA requirement is inappropriate for use by NHTSA given the differences among air brake systems. As mentioned above, FHWA's in-use inspection requirements were developed primarily with drum brake systems in mind, and thus place disc brake systems, long stroke brake chambers and piston-type systems at a competitive disadvantage.

After reviewing the petitions, NHTSA has decided to delete reference to the FHWA requirements and to adopt a requirement that "the adjustment of the service brakes shall be within the limits recommended by the vehicle manufacturer." This language is similar to that of the NPRM (which would have required air brake adjusters to "maintain brake adjustment within the manufacturer's recommended adjustment limits"), in that the adjuster would be required to perform as intended by the vehicle manufacturer. However, NHTSA believes that the language adopted in this document avoids the concerns about objectivity and vagueness engendered by the NPRM.

Those concerns about the NPRM stemmed from the word "maintain" in the language quoted above. Since there was no objective criteria specified for determining whether a particular brake adjuster would "maintain adjustment" of the brakes, manufacturers were concerned that questions could arise between a manufacturer and NHTSA as to whether a particular system complied with the standard, particularly when it was unclear when exactly the determination of compliance would be made. Manufacturers were concerned that the proposed language implied that Standard 121 requires a vehicle to "maintain" conformance to the FMVSS's throughout the life of the vehicle, which is incorrect and confusing.

NHTSA concurred with the commenters that the proposed language was inappropriate (57 FR at 47796):

The agency notes that there is no objective criteria as to what constitutes "maintains

adjustment." In addition, as a general rule, the agency does not establish extended durability testing. The agency believes that to require that the adjustment be maintained throughout the lifetime of the vehicle is unrealistic, dependent upon the vehicle's exposure, and beyond the scope of NHTSA's authority.

The requirement adopted today provides an objective requirement that allows the vehicle manufacturer to evaluate conformance to the standard. As Rockwell stated, NHTSA can readily confirm the compliance of a brake system by comparing the actual readjustment limits of the system with those recommended by the manufacturer. Further, the requirement does not use "maintain" and therefore avoids the implication that compliance with Standard 121 must be maintained through a vehicle's lifetime. However, as explained below, since NHTSA is specifying a requisite level of performance for the brake adjusters, the agency must also specify when, during compliance testing, NHTSA will evaluate the brake adjusters to determine if they are performing according to the recommendations of the vehicle manufacturer.

#### Inspection

During NHTSA's review of the petitions for reconsideration, the agency realized that the standard had no express requirement for when the adjustment indicators are to be inspected. However, the brake adjuster amendment implicitly required that the brakes be inspected, because the amendment states that the readjustment limits must be in accordance with the FHWA inspection standards. Also implicit in this amendment is that inspection will occur at the end of the Standard No. 121 test procedures, since the need for readjustment will only occur after the vehicle has been driven. In addition, inspection of the vehicle at the end of testing for conformance with the braking standard is consistent with the specifications for hydraulic brake systems (Standard No. 105). Accordingly, in this document, NHTSA is including a "final inspection provision" at the end of the test procedures to require that the service brake system be inspected at the end of the test sequence.

#### Procedural Concerns

NHTSA notes that the petitioners' concerns about the adequacy of notice for the FHWA provisions are now moot. Therefore, these concerns are not further addressed.

The amendment to § 571.121 becomes effective October 20, 1994, the effective date for the automatic brake adjusters.

**Regulatory Impacts**

**A. Executive Order 12866 and DOT Regulatory Policies and Procedures**

This notice has not been reviewed under E.O. 12866, "Regulatory Planning and Review." This rulemaking has been determined to be not "significant" under the Department of Transportation regulatory policies and procedures. The amendment will not result in any additional cost impacts beyond those resulting from the initial final rule. The agency further concludes that, because the cost impacts are minimal, a full regulatory evaluation is not required.

**B. Regulatory Flexibility Act**

NHTSA has also considered the impacts of this rulemaking under the Regulatory Flexibility Act. I hereby certify that it will not have a significant economic impact on a substantial number of small entities. Any impact on small entities from this action will be minimal since the amendments make minimal changes to the Standard that will not impose additional costs or result in any savings. Accordingly, the agency has determined that preparation of a regulatory flexibility analysis is unnecessary.

**C. Environmental Impacts**

In accordance with the National Environmental Policy Act of 1969, NHTSA has considered the environmental impacts of this rule. The agency has determined that this rule will not have a significant impact on the quality of the human environment.

**D. Federalism Assessment**

This action has been analyzed in accordance with the principles and criteria contained in Executive Order 12612. NHTSA has determined that the rulemaking does not have sufficient federalism implications to warrant the preparation of a Federalism Assessment. No state laws will be affected.

**E. Civil Justice Reform**

This final rule does not have any retroactive effect. Under section 103(d) of the National Traffic and Motor Vehicle Safety Act (15 U.S.C. 1392(d)), whenever a Federal motor vehicle safety standard is in effect, a state may not adopt or maintain a safety standard applicable to the same aspect of performance which is not identical to the Federal standard. Section 105 of the Act (15 U.S.C. 1394) sets forth a procedure for judicial review of final rules establishing, amending or revoking

Federal motor vehicle safety standards. That section does not require submission of a petition for reconsideration or other administrative proceedings before parties may file suit in court.

**List of Subjects in 49 CFR Part 571**

Imports, Motor vehicle safety, Motor vehicles.

**PART 571—[AMENDED]**

In consideration of the foregoing, 49 CFR Part 571 is amended as follows:

1. The authority citation for Part 571 continues to read as follows:

**Authority:** 15 U.S.C. 1392, 1401, 1403, 1407; delegation of authority at 49 CFR 1.50.

**§ 571.121 [Amended]**

2. Section 571.121 is amended by revising S5.1.8, S5.2.2, and Table I to read as follows and by adding S5.9:

**§ 571.121 Standard No. 121; Air brake systems.**

\* \* \* \* \*

S5.1.8 *Brake distribution and automatic adjustment.* Each vehicle shall be equipped with a service brake system acting on all wheels.

(a) *Brake adjuster.* Wear of the service brakes shall be compensated for by means of a system of automatic adjustment. When inspected pursuant to S5.9, the adjustment of the service brakes shall be within the limits recommended by the vehicle manufacturer.

(b) *Brake indicator.* For each brake equipped with an external automatic adjustment mechanism and having an exposed pushrod, the condition of service brake under-adjustment shall be displayed by a brake adjustment indicator that is discernible when viewed with 20/40 vision from a location adjacent to or underneath the vehicle, when inspected pursuant to S5.9.

\* \* \* \* \*

S5.2.2 *Brake distribution and automatic adjustment.* Each vehicle shall be equipped with a service brake system acting on all wheels.

(a) *Brake Adjuster.* Wear of the service brakes shall be compensated for by means of a system of automatic adjustment. When inspected pursuant to S5.9, the adjustment of the service brakes shall be within the limits recommended by the vehicle manufacturer.

(b) *Brake Indicator.* For each brake equipped with an external automatic adjustment mechanism and having an exposed pushrod, the condition of service brake under-adjustment shall be

displayed by a brake adjustment indicator in a manner that is discernible when viewed with 20/40 vision from a location adjacent to or underneath the vehicle, when inspected pursuant to S5.9.

\* \* \* \* \*

**Table I—Stopping Sequence**

1. Burnish.
2. Control trailer service brake stops at 60 mph (for truck-tractors tested with a control trailer in accordance with S6.1.10.)
3. Control trailer emergency brake stops at 60 mph (for truck-tractors tested with a control trailer in accordance with S6.1.10.7.)
4. Stops with vehicle at gross vehicle weight rating:
  - (a) 20 mph service brake stops on skid number of 81.
  - (b) 60 mph service brake stops on skid number of 81.
  - (c) 20 mph service brake stops on skid number range 30.
  - (d) 20 mph emergency brake stops on skid number of 81.
  - (e) 60 mph emergency brake stops on skid number of 81.
5. Parking brake test with vehicle loaded to GVWR.
6. Stops with vehicle at unloaded weight plus 500 lbs.
  - (a) 20 mph service brake stops on skid number of 81.
  - (b) 60 mph service brake stops on skid number of 81.
  - (c) 20 mph service brake stops on skid number range 30.
  - (d) 20 mph emergency brake stops on skid number of 81.
  - (e) 60 mph emergency brake stops on skid number of 81.
7. Parking brake test with vehicle at unloaded weight plus 500 lbs.
8. Final inspection of service brake system for condition of adjustment.

\* \* \* \* \*

S5.9 *Final Inspection.* Inspect the service brake system for the condition of adjustment and for the brake indicator display in accordance with S5.1.8 and S5.2.2.

\* \* \* \* \*

Issued on April 12, 1994.

**Christopher A. Hart,**  
*Deputy Administrator.*

[FR Doc. 94-9226 Filed 4-15-94; 8:45 am]

BILLING CODE: 4810-69-P

## DEPARTMENT OF THE INTERIOR

## Fish and Wildlife Service

## 50 CFR Part 17

RIN 1018-AC44

## Endangered and Threatened Wildlife and Plants; Emergency Rule To List the Saint Francis' Satyr as Endangered

AGENCY: Fish and Wildlife Service, Interior.

ACTION: Emergency rule.

**SUMMARY:** The Service exercises its emergency authority to determine the Saint Francis' satyr (*Neonympha mitchellii francisci*) to be an endangered species pursuant to the Endangered Species Act of 1973 (Act), as amended. This butterfly is known from a single locality in North Carolina. Recent heavy collecting pressure has resulted in a reduction of the only known population and is believed to pose an imminent threat to the butterfly's existence. Protection from collecting is needed during the species' 1994 flight season while the Service proceeds with adopting permanent protection in accordance with the Act's requirements. This emergency rule will implement Federal protection for 240 days. A proposed rule to list the Saint Francis' satyr as endangered is published elsewhere in today's Federal Register. The proposed rule provides for public comment and a hearing (if requested).

**EFFECTIVE DATE:** This emergency determination is effective on April 18, 1994 and expires on December 14, 1994. Due to the need for protecting the St. Francis' satyr from the effects of collecting, the Service finds that good cause exists for making this rule effective upon publication, as provided by 50 CFR 424.18(b)(1) and the Administrative Procedure Act (5 U.S.C. 553(d)(3)).

**ADDRESSES:** The complete file for this rule is available for inspection, by appointment, during normal business hours at the Asheville Field Office, U.S. Fish and Wildlife Service, 330 Ridgefield Court, Asheville, North Carolina 28806.

**FOR FURTHER INFORMATION CONTACT:** Ms. Nora Murdock at the above address (704/665-1195, Ext. 231).

**SUPPLEMENTARY INFORMATION:****Background**

*Neonympha mitchellii francisci* is a subspecies of one of two North American species of *Neonympha*. One of the rarest butterflies in eastern North America, it was described by Parshall

and Kral in 1989 from material collected in North Carolina. These authors estimated that the single known population probably produced less than 100 adults per year. Shortly thereafter, Saint Francis' satyr was reported to have been collected to extinction (Refsnider 1991, Schweitzer 1989). The subspecies was rediscovered at the type locality in 1992 during the course of a Service-funded status survey. The Act defines "species" to include "any subspecies of fish or wildlife or plants, and any distinct population segment of any species of vertebrate fish or wildlife \* \* \*." Therefore, although *N. m. francisci* is recognized taxonomically as a subspecies, it will be referred to as a "species" throughout the remainder of this emergency rule.

Saint Francis' satyr is a fairly small, dark brown butterfly and is a typical member of the *Satyrinae*, a subfamily of the *Nymphalidae* family, which includes many species commonly called satyrs and wood nymphs. The wingspan for the species ranges from 34 to 44 mm (Opler and Malikus 1992). Saint Francis' satyr and Mitchell's satyr, the northern subspecies (*N. m. mitchellii*), which was classified as endangered on May 20, 1992 (57 FR 21569), are nearly identical in size and show only a slight degree of sexual size dimorphism (Hall 1993, Parshall and Kral 1989). Like most species in the wood nymph group, Saint Francis' satyr has conspicuous "eyespot" on the lower surfaces of the wings. These eyespots are dark maroon brown in the center, reflecting a silver cast in certain lights. The border of these dark eyespots is straw yellow in color, with an outermost border of dark brown. The eyespots are usually round to slightly oval and are well-developed on the fore wing as well as on the hind wing. The spots are accented by two bright orange bands along the posterior wing edges and two darker brown bands across the central portion of each wing. Saint Francis' satyr, like the nominate subspecies, can be distinguished from its North American congener, *N. areolata*, by the latter's well-marked eyespots on the upper wing surfaces and brighter orange bands on the hind wing, as well by its lighter coloration and stronger flight (Refsnider 1991, McAlpine et al. 1960, Wilsman and Schweitzer 1991, Hall 1993).

Saint Francis' satyr is extremely restricted geographically. Mitchell's satyr, the nominate subspecies, has been eliminated from approximately half its known range, primarily due to collecting (Refsnider 1991). Saint Francis' satyr is now known to exist as only a single population in North Carolina.

The annual life cycle of *N. m. francisci*, unlike that of its northern relative, is bivoltine. That is, it has two adult flights or generations per year. Larval host plants are believed to be graminoids such as grasses, sedges, and rushes. Little else is known about the life history of this butterfly. The habitat occupied by this satyr consists primarily of wide, wet meadows dominated by sedges and other wetland graminoids. In the North Carolina sandhills, such meadows are often relicts of beaver activity. Unlike the habitat of Mitchell's satyr, the North Carolina species' habitat cannot be properly called a fen because the waters of this sandhills region are extremely poor in inorganic nutrients. Hall (1993) states:

Whereas true fens—apparently the habitat of the northern form of *N. mitchellii* (Wilsman and Schweitzer 1991)—are circumneutral to basic in pH and are long-lasting features of the landscape, the boggy areas of the sandhills are quite acidic as well as ephemeral, succeeding either to pocosin or swamp forest if not kept open by frequent fire or beaver activity.

Hall (1993) further states:

Under the natural regime of frequent fires ignited by summer thunderstorms, the sandhills were once covered with a much more open type of woodland, dominated by longleaf pine, wiregrass, and other fire-tolerant species. The type of forest that currently exists along [the creek inhabited by Saint Francis' satyr] can only grow up under a long period of fire suppression. The dominance on this site of loblolly pine, moreover, is due primarily to past forestry management practices, not any form of natural succession.

Parshall and Kral speculated that *N. m. francisci* is a relict from a more widespread northern distribution during the Pleistocene period. Hall (1993) presents the following alternative hypothesis:

The current narrow distribution of *francisci* could also be a result of the enormous environmental changes that have occurred in the southern coastal plain just within the past 100 years. Only the discovery of additional populations or fossil remains can clarify this situation.

Extensive searches have been made of suitable habitat in North Carolina and South Carolina, but no other populations of this butterfly have been found (Hall 1993, Schweitzer 1989).

Federal government actions on this species began when it was included as a category 2 species in the November 21, 1991, animal notice of review (56 FR 58804). Category 2 species are those for which the Service believes that Federal listing as endangered or threatened is possibly appropriate but for which conclusive data on biological

vulnerability and threat are not currently available to support proposed rules. Recent surveys have been conducted by Service and State personnel, and the Service now believes sufficient information exists to proceed with an emergency rule to list *Neonympha mitchellii francisci* as endangered.

#### Summary of Factors Affecting the Species

Section 4(a)(1) of the Act (16 U.S.C. 1531 *et seq.*) and regulations (50 CFR part 224) promulgated to implement the listing provisions of the Act set forth the procedures for adding species to the Federal lists. A species may be determined to be an endangered or threatened species due to one or more of the five factors described in section 4(a)(1). These factors and their application to Saint Francis' satyr (*Neonympha mitchellii francisci*) are as follows:

A. *The present or threatened destruction, modification, or curtailment of its habitat or range.* Because of its relatively recent discovery, it is impossible to determine what the original range of Saint Francis' satyr might have been. However, based upon its demonstrated dependency on periodic fires and the general trend of fire suppression on private lands, it seems reasonable to assume that it once occupied a more extensive area. As stated by Hall (1993):

In order for *francisci* to have survived over the past 10,000 years, there must surely have been more populations and greater numbers of individuals than apparently now exist \* \* \* As is true for many species that were once widespread in the sandhills, massive habitat alteration must also be a major factor in the diminution of the range of *francisci* \* \* \* reductions in *francisci*'s range would have accompanied the extensive loss of wetland habitats in the coastal plain. Again, the draining of swamps, pocosins, Carolina bays, savannas, flatwoods, and bogs for conversion to agriculture and silviculture is well known. In the case of *francisci*, however, the extirpation of beavers from the Carolinas may have been the greatest factor.

Beavers had been virtually eliminated from North Carolina by the turn of the century. Reintroductions began in 1939, but it was several decades before they again became an agent for creation of the sedge meadow habitats favored by Saint Francis' satyr (Hall 1993, Woodward and Hazel 1991). Hall further states:

As the landscape mosaic of open woodlands and wetlands of the coastal plain declined throughout the past two centuries, the range of *francisci* must have become increasingly fragmented. Although isolated populations may have persisted as long as

suitable habitat remained, the structure of their meta-populations would have been destroyed. Opportunistic colonization of newly available habitats as well as the repopulation of sites wiped clean by fire or other catastrophe would have become eventually impossible; one by one, the isolated remnants would have blinked out of existence. Although again speculative, the fracturing of meta-populations has been used to explain the decline of the argos skipper and a number of butterflies associated with the tall-grass prairies (Panzer, 1988, D. Schweitzer, pers. comm.). That *francisci* was a relict to begin with only exacerbated this problem; the overall effect was to bring it as close to extinction as any butterfly in the country.

The sole surviving population of this species is now fragmented into less than half a dozen small colonies that occupy a total area no larger than a few square miles.

B. *Overutilization for commercial, recreational, scientific, or educational purposes.* Both subspecies of the Saint Francis' satyr are highly prized by collectors, including commercial collectors who often systematically collect every individual available. Several populations of the nominate subspecies are known to have been obliterated by collectors, and others are believed extremely vulnerable to this threat (Refsnider 1991). As mentioned in the "Background" section, the single known population of Saint Francis' satyr was so hard-hit by collectors in the 3 years following its initial discovery that it was believed to have been collected to extinction. Subsequent to the emergency listing of the nominate subspecies and prior to the publication of this rule, the North Carolina population was the last where *Neonympha mitchellii* could legally be collected. Following the emergency listing of Mitchell's satyr, the North Carolina Heritage Program received several inquiries from collectors about access to the last available population. Several expressed apprehension about any restriction on collecting of this rare and much-sought-after satyr. Collectors reportedly visited the known site every day throughout the flight periods, taking every adult they saw (Hall 1993). After this first wave of over-collection, many unsuccessful searches for the butterfly were made before it was eventually rediscovered. Numbers of individuals then seen were much lower than those reported by Parshall and Kral (1989), with the highest single count consisting of only 11 butterflies (Hall 1993). Even though part of this population is protected from collectors by virtue of being within dangerous artillery impact areas, intensive collecting from the periphery of these areas could reduce

total population numbers below levels needed for long-term survival. Very little is known about this species' life history and ecological requirements, but it appears to be a more vagile species than its northern relative. It may well be dependent upon a large meta-population structure in order to colonize new sites or recolonize those from which it has been extirpated.

C. *Disease or predation.* This butterfly, like others, is undoubtedly consumed by predators, but there is no evidence that predation is a threat to the species at this point. Disease is not known to be a factor in its decline.

D. *The inadequacy of existing regulatory mechanisms.* Insects are not protected from collection under North Carolina law. There are also no Department of Defense regulations that would restrict collecting of Saint Francis' satyr in North Carolina. Federal listing of this species will provide legal protection against indiscriminate taking and illegal trade.

E. *Other natural or manmade factors affecting its continued existence.* Although the habitat occupied by this species is dependent upon some form of disturbance to set back succession (e.g., periodic fire and/or beaver impoundments), intense fires at critical times during the life cycle of the species can eliminate small colonies. Historically, this did not present a problem since there were undoubtedly other adjacent populations that could recolonize extirpated sites. However, the fact that only one population of this species now remains makes it more vulnerable to such threats as catastrophic climatic events, inbreeding depression, disease, and parasitism. Part of the occupied area is adjacent to regularly traveled roads, where there is the threat of toxic chemical spills into the species' wetland habitat. Current military use of the impact areas is favorable to this species; the frequent fires associated with shelling are undoubtedly a principal reason why the species is surviving on military lands and not on surrounding private lands. Department of Defense personnel are aware of the species' plight and have been cooperative in protection efforts. However, heavy siltation is a potential problem that could threaten the small drainages occupied by the species. Although troop movements directly through an area occupied by the satyr could have negative impacts, this has not occurred to date; these activities have now been directed away from areas where the satyr occurs. Other potential threats to the species include pest control programs (for mosquitoes or gypsy moths) and beaver control.

**Reasons for Emergency Determination**

In developing this rule the Service has carefully assessed the best scientific and commercial information available regarding the past, present, and future threats faced by this species. Based on this evaluation, the preferred action is to list Saint Francis' satyr as endangered on an emergency basis. With only one population remaining (and this one having already been diminished by intensive collecting) and with the other subspecies having been completely eliminated from half the States where it historically occurred, the threat of over-collection cannot be denied. The Service has concluded that conducting the normal listing process will delay protection of the species until after the 1994 flight period, thus subjecting the species to an additional year of excessive collecting pressure. The resulting potential for further reduction of this last population could severely reduce the probability of the species' survival. Therefore, the Service is listing the species on an emergency basis to provide maximum protection to the known population during the 1994 flight period.

**Critical Habitat**

Section 4(a)(3) of the Act, as amended, requires that, to the maximum extent prudent and determinable, the Secretary designate critical habitat at the time a species is determined to be endangered or threatened. At this time the Service has made a preliminary finding that designation of critical habitat is not prudent for this species. As discussed under Factor B in the "Summary of Factors Affecting the Species" section, Saint Francis' satyr has already been impacted by over-collecting and continues to be threatened by collecting pressure. Publication of critical habitat descriptions and maps would make the satyr more vulnerable to collection and would increase enforcement problems and the likelihood of extinction. Protection of this species' habitat will be addressed through the recovery process and through the Section 7 jeopardy standard. The single remaining population is located on military lands, where the Department of Defense is aware of its occurrence. Comments regarding the designation of critical habitat will be accepted and reviewed during the comment period established by the proposed rule, which is published in this issue of the **Federal Register**.

**Available Conservation Measures**

Conservation measures provided to species listed as endangered or threatened under the Endangered Species Act include recognition, recovery actions, requirements for Federal protection, and prohibitions against certain practices. Recognition through listing encourages and results in conservation actions by Federal, State, and private agencies, groups, and individuals. The Endangered Species Act provides for possible land acquisition and cooperation with the States and requires that recovery actions be carried out for all listed species. The protection required of Federal agencies and the prohibitions against certain activities involving listed animals are discussed, in part, below.

Section 7(a) of the Act, as amended, requires Federal agencies to evaluate their actions with respect to any species that is proposed or listed as endangered or threatened and with respect to its critical habitat, if any is being designated. Regulations implementing this interagency cooperation provision of the Act are codified at 50 CFR part 402. Section 7(a)(4) requires Federal agencies to confer informally with the Service on any action that is likely to jeopardize the continued existence of a proposed species or result in the destruction or adverse modification of proposed critical habitat. If the species is listed subsequently, Section 7(a)(2) requires Federal agencies to ensure that activities they authorize, fund, or carry out are not likely to jeopardize the continued existence of such a species or to destroy or adversely modify its critical habitat. If a Federal action may affect a listed species or its critical habitat, the responsible Federal agency must enter into formal consultation with the Service. Federal activities that could impact Saint Francis' satyr and its habitat in the future include, but are not limited to, the following: road and firebreak construction, pesticide application, beaver control, troop movements, prescribed burning and fire suppression, and facilities construction. The only known population is located on military lands, where the Department of Defense is already working with the Service to secure the protection and proper management of Saint Francis' satyr while accommodating military activities to the extent possible. Conservation of this butterfly is consistent with most ongoing military operations at the occupied site, and the listing of the species is not expected to result in significant restrictions on military use of the land.

The Act and implementing regulations found at 50 CFR 17.21 set forth a series of general prohibitions and exceptions that apply to all endangered wildlife. These prohibitions, in part, make it illegal for any person subject to the jurisdiction of the United States to take (includes harass, harm, pursue, hunt, shoot, wound, kill, trap, or collect; or to attempt any of these), import or export, ship in interstate commerce in the course of a commercial activity, or sell or offer for sale in interstate or foreign commerce and listed species. It also is illegal to possess, sell, deliver, carry, transport, or ship any such wildlife that has been taken illegally. Certain exceptions apply to agents of the Service and State conservation agencies.

Permits may be issued to carry out otherwise prohibited activities involving endangered wildlife species under certain circumstances. Regulations governing permits are at 50 CFR 17.22 and 17.23. Such permits are available for scientific purposes, to enhance the propagation or survival of the species, and/or for incidental take in connection with otherwise lawful activities.

**References Cited**

- Hall, S. 1993. A rangewide status survey of Saint Francis' satyr *Neonympha mitchellii francisci* (Lepidoptera: Nymphalidae). Report to U.S. Fish and Wildlife Service, Endangered Species Field Office, Asheville, NC. 44 pp.
- McAlpine, W., S. Hubble, and T. Pliske. 1960. The distribution, habits, and life history of *Euptychia mitchellii* (Satyriinae). *J. Lep. Soc.* 14:209-225.
- Opler, P., and V. Malikul. 1992. A field guide to eastern butterflies. Houghton Mifflin Co., New York.
- Parshall, D. K., and T. W. Kral. 1989. A new subspecies of *Neonympha mitchellii* (French) (Satyriinae) from North Carolina. *J. Lep. Soc.* 43:114-119.
- Refsnider, R. 1991. Emergency rule to list the Mitchell's satyr as endangered. *Federal Register* 56(122):28825.
- Schweitzer, D. 1989. A review of category 2 insects in the U.S. Fish and Wildlife Service's Regions 3, 4, and 5. Report to the U.S. Fish and Wildlife Service, Newton Corner, MA. Pp. 132-133.
- Wilsman, L., and D. Schweitzer. 1991. A rangewide status survey of Mitchell's satyr, *Neonympha mitchellii mitchellii* (Lepidoptera: Nymphalidae). Report to the U.S. Fish and Wildlife Service, Region 3, Endangered Species Office, Twin Cities, MN.
- Woodward, D., and R. Hazel. 1991. Beavers in North Carolina; ecology, utilization, and management. Cooperative Extension Service Publication No. AG-434, North Carolina State University, Raleigh, NC.

**Author**

The primary author of this proposed rule is Ms. Nora Murdock (see

ADDRESSES section) (704/665-1195, Ext. 231).

**List of Subjects in 50 CFR Part 17**

Endangered and threatened species, Exports, Imports, Reporting and recordkeeping requirements, and Transportation.

**Regulation Promulgation**

Accordingly, effective April 18, 1994 until December 14, 1994, part 17,

subchapter B of chapter I, title 50 of the Code of Federal Regulations, is amended as set forth below:

**PART 17—[AMENDED]**

(1) The authority citation for part 17 continues to read as follows:

**Authority:** 16 U.S.C. 1361-1407; 16 U.S.C. 1531-1544; 16 U.S.C. 4201-4245; Pub. L. 99-625, 100 Stat. 3500; unless otherwise noted.

(2) Section 17.11(h) is amended by adding the following, in alphabetical order under "Insects," to the List of Endangered and Threatened Wildlife to read as follows:

**§ 17.11 Endangered and threatened wildlife.**

\* \* \* \* \*

(h) \* \* \*

Species		Historic range	Vertebrate population where endangered or threatened	Status	When listed	Critical habitat	Special rules
Common name	Scientific name						
Insects:							
Butterfly, Saint-Francis' satyr.	<i>Neonympha mitchellii francisci</i>	U.S.A. (NC) .....	NA .....	E	539	NA	NA

Dated: April 8, 1994.  
**Mollie H. Beattie,**  
 Director, Fish and Wildlife Service.  
 [FR Doc. 94-9218 Filed 4-17-94; 8:45 am]  
 BILLING CODE 4310-55-M

## Proposed Rules

Federal Register

Vol. 59, No. 74

Monday, April 18, 1994

This section of the FEDERAL REGISTER contains notices to the public of the proposed issuance of rules and regulations. The purpose of these notices is to give interested persons an opportunity to participate in the rule making prior to the adoption of the final rules.

### DEPARTMENT OF THE TREASURY

Office of the Comptroller of the Currency

12 CFR Part 3

[Docket No. 94-05]

RIN 1557-AB14

#### Capital Adequacy; Net Unrealized Holding Gains and Losses on Available-for-Sale Securities

AGENCY: Office of the Comptroller of the Currency, Treasury.

ACTION: Notice of proposed rulemaking.

**SUMMARY:** The Office of the Comptroller of the Currency (OCC) is proposing to amend its capital adequacy rules to revise the definition of common stockholders' equity to include unrealized holding gains and losses on available-for-sale securities, net of applicable tax effects. Inclusion of such unrealized gains and losses as a separate component of stockholders' equity is consistent with Statement of Financial Accounting Standards No. 115, "Accounting for Certain Investments in Debt and Equity Securities," and would keep the OCC's definition of common stockholders' equity consistent with generally accepted accounting principles (GAAP). As Tier 1 capital under the OCC's capital adequacy rules is defined to include common stockholders' equity, this proposal, if adopted, would require these net unrealized holding gains and losses to be considered in determining the amount of an institution's Tier 1 capital.

**DATES:** Comments should be submitted on or before May 18, 1994.

**ADDRESSES:** Comments on the OCC's proposal may be submitted to Docket No. 94-05, Communications Division, Ninth floor, Office of the Comptroller of the Currency, 250 E Street, SW., Washington, DC 20219. Comments will be available for inspection and photocopying at that address.

**FOR FURTHER INFORMATION CONTACT:** Zane D. Blackburn, Chief Accountant,

(202) 874-5180; Roger Tufts, Senior Economic Advisor, Office of the Chief National Bank Examiner, (202) 874-5070; Ronald Shimabukuro, Senior Attorney, Bank Operations and Assets Division, (202) 874-4460, Office of the Comptroller of the Currency.

#### SUPPLEMENTARY INFORMATION:

##### Background

Under the current OCC minimum capital requirements (leverage ratio) and the risk-based capital guidelines set forth at 12 CFR part 3, a major component of Tier 1 capital is common stockholders' equity. Common stockholders' equity is defined to include (1) common stock, (2) common stock surplus, (3) undivided profits, (4) capital reserves, (5) adjustments for the cumulative effect of foreign currency translation, and (6) net unrealized losses on non-current marketable equity securities. The net unrealized losses are those recorded under Statement of Financial Accounting Standards No. 12, "Accounting for Certain Marketable Securities" (SFAS 12).

In May 1993, the Financial Accounting Standards Board issued Statement of Financial Accounting Standards No. 115, "Accounting for Certain Investments in Debt and Equity Securities," (SFAS 115). This statement supersedes SFAS 12 and establishes a new component of common stockholders' equity consisting of net unrealized holding gains and losses on available-for-sale securities. Under SFAS 115, available-for-sale securities are those securities which a bank does not have the positive intent and ability to hold to maturity, but does not intend to trade actively as part of its trading account.

In August 1993, the OCC, the Federal Reserve Board, The Federal Deposit Insurance Corporation, and the Office of Thrift Supervision, announced the adoption of SFAS 115 for regulatory reporting purposes. The OCC now proposes to adopt SFAS 115 for regulatory capital purposes as well.

##### SFAS 115

SFAS 115 applies for all debt securities and certain equity securities that have readily determinable fair values. The statement establishes new accounting and reporting requirements for such securities effective for fiscal years beginning after December 15,

1993, but banks have the option of adopting the statement as of the end of an earlier fiscal year. For most banks, that would be as of December 31, 1993.

SFAS 115 requires banks to divide their securities holdings among three categories: securities held-to-maturity, trading securities, and available-for-sale securities. Each category of security is accounted for differently.

##### Held-to-Maturity

The held-to-maturity category replaces the existing held for investment category. Presently, securities held for investment are recorded at amortized cost. Under SFAS 115, securities in the held-to-maturity category will be recorded at amortized cost. However, only those securities that a bank has both the positive intent and ability to hold to maturity may be included in this account.

This change will restrict a bank's ability to carry securities at amortized cost. For example, if a bank has the intent to hold a security for only an indefinite period, the security cannot be classified as held-to-maturity. Consequently, if a security would be sold in response to (1) changes in market interest rates and related changes in the security's prepayment risk, (2) liquidity needs, (3) changes in the availability of and yield on alternative investments, (4) changes in funding sources and terms, or (5) changes in foreign currency risk, then it must be assigned to either the available-for-sale or trading categories.

Nonetheless, changes in circumstances may occur that cause a bank to change its intent to hold a security to maturity. SFAS 115 notes that a sale or transfer of a security from the held-to-maturity account in response to events that are isolated, nonrecurring, and unusual and that could not have been anticipated, would not necessarily call into question the bank's intent to hold other securities to maturity.

##### Trading Securities

The accounting for trading securities has not changed. Trading securities are those debt and equity securities that a bank buys and holds principally for the purpose of selling in the near term. Trading securities will continue to be recorded at fair value with unrealized changes in fair value reported directly



in the income statement as part of the bank's earnings.

#### Available-for-Sale

All securities that are not classified as either held-to-maturity or trading will be considered available-for-sale securities. The available-for-sale category replaces the existing held-for-sale category. However, it is likely to include some securities previously considered held for investment. The accounting treatment also has changed. Under existing accounting requirements, held-for-sale securities are carried at the lower of cost or fair value, with the offsetting entry reported directly in the income statement. Under SFAS 115, available-for-sale securities will be recorded at fair value and any unrealized appreciation or depreciation will be excluded from earnings and reported, net of applicable tax effects, as a separate component of common stockholders' equity.

#### Impact of SFAS 115 on Regulatory Capital

This proposed rule would amend the OCC's capital adequacy rules by revising the definition of common stockholders' equity. Specifically, the proposed rule would remove the adjustment for net unrealized losses on non-current marketable equity securities and replace it with the net unrealized holding gains and losses on available-for-sale securities under SFAS 115. Since common stockholders' equity is a component of Tier 1 capital, the proposed rule would affect the calculation of an institution's Tier 1 capital under the OCC's capital adequacy rules. This amendment is intended to adopt SFAS 115 for regulatory capital purposes and to ensure greater consistency with GAAP.

As discussed earlier, SFAS 115 restricts the circumstances in which securities may be reported at amortized cost. Thus, a greater proportion of a national bank's securities will be carried at fair value. While this proposed rule to adopt SFAS 115 for regulatory capital purposes will not affect reported earnings, it could result in an increase in the volatility of regulatory capital. Under the current interest rate environment, the precise impact of this proposed rule is difficult to predict. Until recently, interest rates were declining. Consequently, the fair value for most banks' securities portfolios generally exceeded their book value. Therefore, the impact of this proposal likely would have resulted in an increase in the regulatory capital of national banks. However, with the recent upturn in interest rates, it is not

possible to generalize the impact of this proposed rule on regulatory capital. Over time, as the interest rate environment changes, the proposed rule could result in periods of lower regulatory capital for some national banks and possibly subject a bank to regulatory action under the OCC's prompt corrective action rules. See 12 CFR part 6. Nonetheless, while the amount of regulatory capital may vary with changes in interest rates, banks can exercise some control over the volatility through effective interest rate risk management techniques.

#### Issues for Comment

The OCC invites comments on all aspects of this proposal regarding the regulatory capital treatment of net unrealized holding gains and losses on available-for-sale securities. However, the OCC specifically seeks comment on (1) the costs and benefits of adopting SFAS 115 for regulatory capital purposes, and (2) the extent to which banks will adjust their behavior to manage the potential volatility in regulatory capital if the OCC adopts the proposed rule.

#### Regulatory Flexibility Act

Pursuant to section 605(b) of the Regulatory Flexibility Act, it is hereby certified that this regulation will not have a significant economic impact on a substantial number of small entities. Accordingly, a regulatory flexibility analysis is not required.

This rule may increase the volatility of small banks' regulatory capital. However, it should not lead to a significant increase in the number of small banks that do not meet regulatory capital standards because most small banks operate with capital levels well above regulatory capital standards. Even if there were a significant decline in the market value of banks' available-for-sale securities, most banks would still meet regulatory standards.

#### Executive Order 12866

It has been determined that this document is not a significant regulatory action under Executive Order 12866. This proposed rule affects the method of calculating regulatory capital. This proposed rule is intended to amend the capital adequacy rules to make the definition of common stockholders' equity for regulatory capital consistent with GAAP. This proposed rule should not have a material impact upon national banks.

#### List of Subjects in 12 CFR Part 3

Administrative practice and procedure, National banks, Reporting and recordkeeping requirements.

#### Authority and Issuance

For the reasons set out in the preamble, title 12, chapter I, part 3 of the Code of Federal Regulations is proposed to be amended as set forth below.

#### PART 3—MINIMUM CAPITAL RATIOS; ISSUANCE OF DIRECTIVES

1. The authority citation for part 3 is revised to read as follows:

**Authority:** 12 U.S.C. 93a, 161, 1818, 1828(n), 1828 note, 1831n note, 3907, and 3909.

2. In appendix A, section 1, paragraph (c)(7) is revised to read as follows:

#### Appendix A to Part 3—Risk-Based Capital Guidelines

*Section 1. Purpose, Applicability of Guidelines, and Definitions.*

\* \* \* \* \*

(c) \* \* \*

(7) *Common stockholders' equity* means common stock, common stock surplus, undivided profits, capital reserves, adjustments for the cumulative effect of foreign currency translation and net of unrealized holding gains or losses on available-for-sale securities.

\* \* \* \* \*

**Editorial Note:** This document was received by the Office of the Federal Register on April 13, 1994.

Dated: October 25, 1993.

Eugene A. Ludwig,

Comptroller of the Currency.

[FR Doc. 94-9271 Filed 4-15-94; 8:45 am]

BILLING CODE 4810-33-P

#### DEPARTMENT OF TRANSPORTATION

#### Federal Aviation Administration

#### 14 CFR Part 71

[Airspace Docket No. 94-ASO-3]

#### Proposed Amendment of Offshore Airspace Area, San Juan, PR

AGENCY: Federal Aviation Administration (FAA), DOT.

ACTION: Notice of proposed rulemaking.

**SUMMARY:** This notice proposes to amend the Offshore Airspace Area at Puerto Rico. This action would lower the base of the San Juan Offshore Airspace Area from 5500 feet MSL to 2500 feet MSL. The intended effect is to lower the base of the Offshore Airspace Area to provide sufficient controlled

airspace for instrument flight rule (IFR) operations, and to create a uniform base of controlled airspace in the area.

**DATES:** Comments must be received on or before: May 25, 1994.

**ADDRESSES:** Send comments on the proposal in triplicate to: Federal Aviation Administration, Docket No. 94-ASO-3, Manager, System Management Branch, ASO-530, P.O. Box 20636, Atlanta, Georgia 30320.

The official docket may be examined in the Office of the Assistant Chief Counsel for Southern Region, room 530, 1701 Columbia Avenue, College Park, Georgia 30337, telephone (404) 305-5200.

**FOR FURTHER INFORMATION CONTACT:** Kenneth R. Patterson, Airspace Section, System Management Branch, Air Traffic Division, Federal Aviation Administration, P.O. Box 20636, Atlanta, Georgia 30320; telephone (404) 305-5585.

**SUPPLEMENTARY INFORMATION:**

**Comments Invited**

Interested parties are invited to participate in this proposed rulemaking by submitting such written data, views or arguments as they may desire. Comments that provide the factual basis supporting the views and suggestions presented are particularly helpful in developing reasoned regulatory decisions on the proposal. Comments are specifically invited on the overall regulatory, aeronautical, economic, environmental, and energy aspects of the proposal. Communications should identify the airspace docket and be submitted in triplicate to the address listed above. Commenters wishing the FAA to acknowledge receipt of their comments on this notice must submit with those comments a self-addressed, stamped postcard on which the following statement is made: "Comments to Airspace Docket No. 94-ASP-3." The postcard will be date/time stamped and returned to the commenter. All communications received before the specified closing date for comments will be considered before taking action on the proposed rule. The proposal contained in this notice may be changed in the light of comments received. All comments submitted will be available for examination in the Office of the Assistant Chief Counsel for Southern Region, room 530, 1701 Columbia Avenue, College Park, Georgia 30337, both before and after the closing date for comments. A report summarizing each substantive public contact with FAA personnel concerned with this rulemaking will be filed in the docket.

**Availability of NPRM's**

Any person may obtain a copy of this Notice of Proposed Rulemaking (NPRM) by submitting a request to the Federal Aviation Administration, Manager, System Management Branch (ASO-530), Air Traffic Division, P.O. Box 20636, Atlanta, Georgia 30320.

Communications must identify the notice number of this NPRM. Persons interested in being placed on a mailing list for future NPRM's should also request a copy of Advisory Circular No. 11-2A, which describes the application procedure.

**The Proposal**

The FAA is considering an amendment to part 71 of the Federal Aviation Regulations (14 CFR part 71) to amend the Offshore Airspace Area at San Juan, PR. The intended effect is to lower the base of the Offshore Airspace Area from 5500 feet MSL to 2500 feet MSL, to contain IFR operations in controlled airspace, and to create a uniform base of controlled airspace in the area. The base of this controlled airspace was increased to 5500 feet during the airspace reclassification for the purpose of creating a standard 5500 ft. base of controlled airspace in all the surrounding areas, however, the base of all airspace surrounding the San Juan Offshore Airspace was never increased to 5500 ft. and remains at 2500 feet MSL. It has also been found with the base at 5500 feet, air traffic control does not have sufficient airspace for IFR traffic arriving and departing Rafael Hernandez Airport. The coordinates for this airspace docket are based on North American Datum 83. Designations for Offshore Airspace Areas are published in Paragraph 6007 of FAA Order 7400.9A dated June 17, 1993 and effective September 16, 1993 which is incorporated by reference in CFR 71.1. The Offshore Airspace Area designation listed in this document would be published subsequently in the Order.

The FAA has determined that this proposed regulation only involves an established body of technical regulations for which frequent and routine amendments are necessary to keep them operationally current. It, therefore, (1) is not a "significant regulatory action" under Executive Order 12866; (2) is not a "significant rule" under DOT Regulatory Policies and Procedures (44 FR 11034; February 26, 1979); and (3) does not warrant preparation of a regulatory evaluation as the anticipated impact is so minimal. Since this is a routine matter that will only affect air traffic procedures and air navigation, it is certified that this rule,

when promulgated, will not have a significant economic impact on a substantial number of small entities under the criteria of the Regulatory Flexibility Act.

**List of Subjects in 14 CFR Part 71**

Aviation safety, Incorporation by reference, Navigation (Air).

**The Proposed Amendment**

In consideration of the foregoing, the Federal Aviation Administration proposes to amend 14 CFR part 71 as follows:

**PART 71—[AMENDED]**

1. The authority citation for 14 CFR part 71 continues to read as follows:

**Authority:** 49 U.S.C. app. 1348(a), 1510; E.O. 10854, 24 FR 9565, 3 CFR, 1959-1963 Comp., p. 389; 49 U.S.C. 106(g); 14 CFR 11.69.

**§ 71.1 [Amended]**

2. The incorporation by reference in 14 CFR 71.1 of the Federal Aviation Administration Order 7400.9A, Airspace Designations and Reporting Points, dated June 17, 1993 and effective September 16, 1993, is amended as follows:

*Para. 6007 Offshore Airspace Areas*  
\* \* \* \* \*

**San Juan Low, PR [Amended]**

Fernando Luis Ribas Dominicci Airport, PR (lat. 18°27'25" N, long. 66°05'53" W)

That airspace extending upward from 2,500 feet MSL within a 100-mile radius of the Fernando Luis Ribas Dominicci Airport.  
\* \* \* \* \*

Issued in College Park, Georgia, on March 30, 1994.

**Michael J. Powderly,**

*Acting Manager, Air Traffic Division, Southern Region.*

[FR Doc. 94-9222 Filed 4-15-94; 8:45 am]

**BILLING CODE 4910-13-M**

**DEPARTMENT OF THE INTERIOR**

**Office of Surface Mining Reclamation and Enforcement**

**30 CFR Part 914**

**Indiana Regulatory Program Amendment**

**AGENCY:** Office of Surface Mining Reclamation and Enforcement (OSM), Interior.

**ACTION:** Proposed rule.

**SUMMARY:** OSM is announcing receipt of a proposed amendment to the Indiana regulatory program (hereinafter referred

to as the "Indiana program") under the Surface Mining Control and Reclamation Act of 1977 (SMCRA). The proposed amendment (#94-1) consists of revisions to the Indiana statutes as may be the Indiana General Assembly and contained in Senate Enrolled Act (SEA) 408, SEA 319, and House Enrolled Act (HEA) 1516. The amendment is intended to revise the Indiana program to be consistent with SMCRA and to incorporate State initiatives.

**DATES:** Written comments must be received by 4:00 p.m., e.s.t. May 18, 1994. If requested, a public hearing on the proposed amendment will be held on May 13, 1994. Requests to speak at the hearing must be received by 4:00 p.m., e.s.t. on May 3, 1994. Any disabled individual who has need for a special accommodation to attend a public hearing should contact the individual listed under "FOR FURTHER INFORMATION CONTACT."

**ADDRESSES:** Written comments and requests to speak at the hearing should be mailed or hand delivered to Roger W. Calhoun, Director, Indianapolis Field Office at the first address listed below.

Copies of the Indiana program the proposed amendment, a listing of any scheduled public hearings, and all written comments received in response to this document will be available for public review at the addresses listed below during normal business hours, Monday through Friday, excluding holidays. Each requester may receive one free copy of the proposed amendment by contacting OSM's Indianapolis Field Office.

Roger W. Calhoun, Director,  
Indianapolis Field Office,  
Office of Surface Mining Reclamation  
and Enforcement,  
Minton-Capehart Federal Building,  
Room 301,  
Indianapolis, Indiana 46204,  
Telephone: (317) 226-6166  
Indiana Department of Natural  
Resources, 402 West Washington  
Street, Room C256, Indianapolis,  
Indiana 46204, Telephone: (317) 232-  
1547

**FOR FURTHER INFORMATION CONTACT:**  
Roger W. Calhoun, Director,  
Indianapolis Field Office, Telephone:  
(317) 226-6166.

**SUPPLEMENTARY INFORMATION:**

- I. Background on the Indiana Program
- II. Discussion of the Proposed Amendment
- III. Public Comment Procedures
- IV. Procedure Determinations

**I. Background on the Indiana Program**

On July 29, 1982, the Secretary of the Interior conditionally approved the

Indiana program. Background information on the Indiana program, including the Secretary's findings, the disposition of comments, and the conditions of approval can be found in the July 26, 1982, *Federal Register* (47 FR 32071). Subsequent actions concerning the conditions of approval and program amendments can be found at 30 CFR 914.10, 914.15, and 914.16.

**II. Discussion of the Proposed Amendment**

By letter dated March 21, 1994, (Administrative Record No. IND-1341) Indiana submitted a proposed amendment to its program pursuant to SMCRA. The amendment consists of numerous program changes in the form of three sets of legislative changes.

The first set of amended legislative provisions are contained in the 1994 SEA 408. These provisions concern bond forfeiture procedures, underground mine subsidence control, and permit revocation procedures. The provisions being amended by SEA 408 are:

IC 13-4.1-6-9 Forfeiture of bond; use of funds collected [Amend]

IC 13-4.1-9-2.5 Underground mining; subsidence; repair or compensation for damage [New]

IC 13-4.1-11-6 Suspension or revocation of permit [Amend]

The second set of amended provisions is contained in the 1987 SEA 319 (Pub. L. 7-1987). These provisions are intended primarily to substitute the then-repealed IC 4-22-1 with IC 4-21.5 concerning administrative orders and procedures. The provisions amended by SEA 319 are:

IC 13-4.1-2-4 Petition to adopt, amend or repeal rule; procedure [Amend]

IC 13-4.1-4-3 Burden of establishing compliance; prime farmland [Amend]

IC 13-4.1-4-5 Issuance of permit; hearing on final determination [Amend]

IC 13-4.1-6-7 Release of bond or deposit [Amend]

IC 13-4.1-11-6 Suspension or revocation of permit [Amend]

IC 13-4.1-11-8 Review of notice or order; hearing; final decision; temporary relief [Amend]

IC 13-4.1-12-1 Civil penalties [Amend]

IC 13-4.1-13-1 Action of the director or commission subject to review [Amend]

IC 13-4.1-15-9 Hearings; use or disposition of acquired lands [Amend]

The third set of amended provisions is contained in the 1987 HEA 1516 (Pub.

L. 13-1987). This provision amends the conflict of interest provisions to require members of the Indiana Natural Resources Commission to file financial interest reports with the Indiana State Board of Accounts. The specific provision being amended by HEA 1516 is:

IC 13-4.1-2-3 Conflict of interest; offense [Amend]

**III. Public Comment Procedures**

In accordance with the provisions of 30 CFR 732.17(h), OSM is seeking comments on whether the proposed amendment satisfies the applicable program approval criteria of 30 CFR 732.15. If the amendment is deemed adequate, it will become part of the Indiana program.

*Written Comments*

Written comments should be specific, pertain only to the issues proposed in this rulemaking, and include explanations in support of the commenter's recommendations. Comments received after the time indicated under "DATES" or at locations other than the Indianapolis Field Office will not necessarily be considered in the final rulemaking or included in the Administrative Record.

*Public Hearing*

Persons wishing to speak at the public hearing should contact the person listed under "FOR FURTHER INFORMATION CONTACT" by 4:00 p.m., e.s.t. on May 3, 1994. The location and time of the hearing will be arranged with those persons requesting the hearing. If no one requests an opportunity to testify at the public hearing, the hearing will not be held.

Filing of a written statement at the time of the hearing is requested as it will greatly assist the transcriber. Submission of written statements in advance of the hearing will allow OSM officials to prepare adequate responses and appropriate questions.

The public hearing will continue on the specified date until all persons scheduled to speak have been heard. Persons in the audience who have not been scheduled to speak, and who wish to do so, will be heard following those who have been scheduled. The hearing will end after all persons scheduled to speak and persons present in the audience who wish to speak have been heard.

*Public Meeting*

If only one person requests an opportunity to speak at a hearing, a public meeting, rather than a public hearing, may be held. Persons wishing

to meet with OSM representatives to discuss the proposed amendment may request a meeting by contacting the person listed under "FOR FURTHER INFORMATION CONTACT." All such meetings will be open to the public and, if possible, notices of meetings will be posted in advance at the locations listed under "ADDRESSES." A written summary of each meeting will be made a part of the Administrative Record.

#### IV. Procedural Determinations

##### Executive Order 12866

This proposed rule is exempted from review by the Office of Management and Budget (OMB) under Executive Order 12866 (Regulatory Planning and Review).

##### Executive Order 12778

The Department of the Interior has conducted the reviews required by section 2 of Executive Order 12778 (Civil Justice Reform) and has determined that, to the extent allowed by law, this rule meets the applicable standards of subsections (a) and (b) of that section. However, these standards are not applicable to the actual language of State regulatory programs and program amendments since each such program is drafted and promulgated by a specific State, not by OSM. Under sections 503 and 505 of SMCRA (30 U.S.C. 1253 and 1255) and 30 CFR 730.11, 732.15, and 732.17(h)(10), decisions on proposed State regulatory programs and program amendments submitted by the States must be based solely on a determination of whether the submittal is consistent with SMCRA and its implementing Federal regulations and whether the other requirements of 30 CFR Parts 730, 731, and 732 have been met.

##### National Environmental Policy Act

No environmental impact statement is required for this rule since section 702(d) of SMCRA (30 U.S.C. 1292(d)) provides that agency decisions on proposed State regulatory program provisions do not constitute major Federal actions within the meaning of section 102(2)(C) of the National Environmental Policy Act (42 U.S.C. 4332(2)(C)).

##### Paperwork Reduction Act

This rule does not contain information collection requirements that require approval by OMB under the Paperwork Reduction Act (44 U.S.C. 3507 *et seq.*).

##### Regulatory Flexibility Act

The Department of the Interior has determined that this rule will not have

a significant economic impact on a substantial number of small entities under the Regulatory Flexibility Act (5 U.S.C. 601 *et seq.*). The State submittal which is the subject of this rule is based upon counterpart Federal regulations for which an economic analysis was prepared and certification made that such regulations would not have a significant economic effect upon a substantial number of small entities. Accordingly, this rule will ensure that existing requirements previously promulgated by OSM will be implemented by the State. In making the determination as to whether this rule would have a significant economic impact, the Department relied upon the data and assumptions for the counterpart Federal regulations.

##### List of Subjects in 30 CFR Part 914

Intergovernmental relations, Surface mining, Underground mining.

Dated: April 12, 1994.

Robert J. Biggi,

Acting Assistant Director, Eastern Support Center.

[FR Doc. 94-9261 Filed 4-15-94; 8:45 am]

BILLING CODE 4310-05-M

#### PANAMA CANAL COMMISSION

##### 35 CFR Parts 133 and 135

RIN 3207-AA23

##### Tolls for Use of Canal and Rules for Measurement of Vessels

AGENCY: Panama Canal Commission.

ACTION: Advance notice of proposed rulemaking; request for comments; notice of hearing.

SUMMARY: The Panama Canal Commission proposes a major revision of the rules for measurement of vessels using the Panama Canal to become effective October 1, 1994. The existing rules of measurement will be replaced with a simplified, objective approach which brings the Commission's system in line with an international practice which will enter into full application worldwide on July 18, 1994. The proposed rules apply a mathematical formula to the vessel's total volume to produce the basis for assessing tolls. The tonnage values computed under the proposed system are comparable to those calculated under the Commission's existing rules and, in the aggregate, are equal to existing tonnages; accordingly, no changes are proposed to the rates of toll for use of the Canal; however, certain administrative changes to the regulations dealing with Canal

tolls are necessary to ensure their consistency with the revised rules of measurement.

This advance notice of proposed rulemaking announces the availability from the Commission of an analysis showing the basis of and justification for the proposed changes, solicits written data and comments from interested parties, and sets the time and place for a public hearing.

DATES: Written comments and requests to present oral testimony must be received on or before May 19, 1994; a public hearing will be held on May 25, 1994 at 9:30 a.m.

ADDRESSES: Comments and requests to testify at the hearing may be mailed to: Michael Rhode, Jr., Secretary, Panama Canal Commission, 1825 I Street NW., suite 1050, Washington, DC 20006-5402, (Telephone: (202) 634-6441) (Facsimile: (202) 634-6439); copies of the Commission's analysis showing the basis of and justification for the proposed changes are available from the Commission (at the above address) or from the Office of Financial Management, Panama Canal Commission, Balboa Heights, Republic of Panama (Telephone: 011-507-52-3194) (Facsimile: 011-507-52-3040).

The hearing will be held in the ANA Hotel, 2401 M Street NW., Washington, DC 20037. Oral presentations should be limited to 20 minutes. Regulations governing the content of the notice of appearance or intention to present supplementary data at the hearing appear in 35 CFR 70.8 and 70.10.

FOR FURTHER INFORMATION CONTACT: Michael Rhode, Jr. at the above address and telephone.

SUPPLEMENTARY INFORMATION: A complete revision to the Rules for Measurement of Vessels for the Panama Canal contained in 35 CFR part 135 is proposed. The proposed revision is designed to simplify the Commission's measurement procedures which since the Canal's inception have been based on the Moorsom system. The change is designed to bring measurement rules at the Canal in line with the worldwide standard of tonnage measurement and achieve compatibility with the 1969 International Convention on Tonnage Measurement of Ships (Convention). The Convention, which establishes a universal system of measurement for vessels engaged on an international voyage, came into effect in the United States on February 10, 1983.

This new 35 CFR part 135 would provide for:

a. Establishment of measurement rules for the Panama Canal Commission

which are based on Annex 1 of the Convention;

b. Transitional relief measures for certain vessels, provided they do not have a structural change which results in an alteration of 10 percent or more in their total volume;

c. Continued use of foreign tonnage authorities, and for acceptance of reasonably accurate volumes provided by them;

d. Correction of tonnage values as necessary to satisfy the Commission's desire for accuracy; and

e. Calculation of volumes for vessels without an International Tonnage Certificate 1969 (ITC 69) through an alternative tonnage estimating formula.

Subpart A contains general provisions concerning the uses of the Panama Canal Universal Measurement System (PC/UMS) Net Tonnage for the purpose of calculating tolls and admeasurement fees. It provides for the presentation of an ITC 69 or suitable substitute or the application of alternative measurement procedures. It retains provision for Commission control over the measurement determination, verification of tonnage certificates and the administration of these rules.

Subpart B establishes the PC/UMS. Under it, tolls will be assessed on the basis of the PC/UMS Net Ton. The Commission will apply a mathematical formula to the total volume in order to determine the PC/UMS Net Tonnage. This formula has been established so as to produce tonnage and, hence, revenues that in the aggregate are equal to those produced under the current system annually. Relevant definitions are set forth in this subpart. The subpart also establishes the rules concerning measurement and calculations. Finally, the subpart addresses measurement rules in the event of a total volume change.

Subpart C continues without substantive change the present rules for the measurement of warships, dredges and floating drydocks. Tolls for these vessels will continue to be based on their tonnage of actual displacement.

Subpart D provides transitional relief measures for vessels which previously transited the Canal and have not had a significant structural change.

Subpart E sets forth the measurement procedures the Commission will use when it becomes necessary for the Commission to determine the total volume of a vessel.

In addition to the changes to 35 CFR part 135, certain administrative changes to 35 CFR part 133 (Tolls for Use of Canal) are required. These changes will reconcile the language of part 133 with new part 135 by allowing for the use of

the ITC 69 to obtain the required total volume information.

Section 1604 of the Panama Canal Act of 1979, as amended, 22 U.S.C. 3794, establishes the procedures that the Commission must follow in proposing changes in the rules for measurement of vessels. Those procedures have been supplemented by regulations in 35 CFR part 70, which provide interested parties with instructions for participating in the process governing changes in the measurement rules. The statute and regulations require this advance notice of proposed rulemaking in order for the Commission to announce the proposed changes and afford interested parties an opportunity to submit written data or comments and to participate in the public hearing on May 25, 1994. A written analysis is also made available to the public showing the basis of and justification for the revision.

All pertinent data or comments presented in writing, or orally at the hearing, will be considered, along with other relevant information, before the Commission publishes a notice of proposed rulemaking in the *Federal Register* and forwards a complete record and its final recommendation to the President of the United States. In considering the proposal, the President has the authority to approve, disapprove, or modify any recommendation of the Commission. The final rule, approved and published by the President, shall be effective October 1, 1994, or 30 days from the date of publication in the *Federal Register*, whichever occurs later.

The Commission has been exempted from Executive Order 12866 and, accordingly, the provisions of that directive do not apply to this proposed rule. Even if the Order were applicable, the proposed regulation, which concerns "rates" and "practices relating" thereto, would not constitute a "rule" as that term is defined in the Regulatory Flexibility Act (5 U.S.C. 601(2)) and would not have a significant impact on a substantial number of small entities under that Act.

A review of the environmental effect of the proposed measurement rule changes concludes that the proposed change will not have a significant effect on the quality of the human environment. An environmental impact statement is not required under the National Environmental Policy Act of 1969.

Finally, the Administrator of the Panama Canal Commission certifies that these proposed regulations meet the applicable standards provided in

sections 2(a) and 2(b)(2) of Executive Order No. 12778.

#### List of Subjects in 35 CFR Parts 133 and 135

Measurement, Navigation, Panama Canal, Vessels.

Accordingly, it is proposed that 35 CFR parts 133 and 135 be amended as follows:

#### PART 133—TOLLS FOR USE OF CANAL

3. The authority citation for part 133 continues to read as follows:

**Authority:** Issued under authority of the President by 22 U.S.C. 3791, E.O. 12215, 45 FR 36043.

4. Section 133.1 is amended by revising the introductory text and paragraphs (a) and (b) to read as follows:

##### § 133.1 Rates of toll.

The following rates of toll shall be paid by vessels using the Panama Canal:

(a) On merchant vessels, yachts, army and navy transports, colliers, hospital ships, and supply ships, when carrying passengers or cargo, \$2.21 per PC/UMS Net Ton—that is, the net tonnage determined in accordance with part 135 of this chapter.

(b) On vessels in ballast without passengers or cargo, \$1.76 per PC/UMS Net Ton.

\* \* \* \* \*

5. Section 133.31 is revised to read as follows:

##### § 133.31 Measurement of vessels; vessels to secure tonnage certificate.

The rules for the measurement of vessels are fixed by part 135 of this chapter. Vessels desiring to transit the Canal shall provide themselves with a tonnage certificate in accordance with § 133.32.

6. Section 133.32 is revised to read as follows:

##### § 133.32 Measurement of vessels; making and correction of measurements; plans and copies.

Measurements may be made by the admeasurers of the Canal or certain other officials worldwide as designated by the Panama Canal Commission. Each transiting vessel should have aboard and available to Canal authorities a full set of plans and a copy of the measurements which were made at the time of issue of its International Tonnage Certificate (1969), as well as the tonnage certificate itself. A copy of the International Tonnage Certificate (1969) shall be provided to Canal authorities. The Commission reserves the right to check and correct the total

volume that is to be used in the calculation of the Panama Canal Universal Measurement System Net Tonnage.

7. Section 133.33 is revised to read as follows:

**§ 133.33 Measurement of vessels; temporary retention of certificate at Canal.**

The official Panama Canal Universal Measurement System Net Tonnage certificate will be delivered by the Canal authorities to the vessel or to the owner or agent of the vessel after transit completion. This certificate will be retained on board the vessel and will be used to certify that the vessel has been inspected and its Panama Canal Universal Measurement System Net Tonnage has been determined by the Commission.

**PART 135—RULES FOR MEASUREMENT OF VESSELS**

8. Part 135 is revised to read as follows:

**Subpart A—General Provisions**

Sec.

135.1 Scope.

135.2 Vessels generally to present tonnage certificate or be measured.

135.3 Determination of total volume.

135.4 Administration and interpretation of rules.

**Subpart B—PC/UMS Net Tonnage Measurement**

135.11 Tonnage.

135.12 Definitions.

135.13 Determination of PC/UMS net tonnage.

135.14 Change of PC/UMS net tonnage.

135.15 Calculation of volumes.

135.16 Measurement and calculation.

**Subpart C—Warships, Dredges and Floating Drydocks**

135.21 Warships, dredges and floating drydocks to present documents stating displacement tonnage.

135.22 Tolls on warships, dredges and floating drydocks levied on actual displacement.

**Subpart D—Transitional Relief Measures**

135.31 Vessels eligible for transitional relief measures.

**Subpart E—Alternative Method for Measurement of Vessels**

135.41 Measurement of ships when volume information is not available.

135.42 Measurement of ships when tonnage cannot be otherwise ascertained.

**Authority:** Issued under authority of the President by 22 U.S.C. 3791, E.O. 12215, 45 FR 36043.

**Subpart A—General Provisions**

**§ 135.1 Scope.**

This part establishes the procedures for determining the Panama Canal Universal Measurement System (hereinafter PC/UMS) Net Tonnage. The tonnage will be used to assess tolls for use of the Panama Canal. Also, the tonnage may be used, when adequate volume information is not provided, to assess the charge for admeasurement services.

**§ 135.2 Vessels generally to present tonnage certificate or be measured.**

All vessels except warships, floating drydocks, dredges, and vessels eligible for transitional relief measures, applying for passage through the Panama Canal shall present a duly authenticated International Tonnage Certificate (1969) (hereinafter ITC 69), or suitable substitute (i.e., a certificate derived from a system which is substantially similar to that which was provided for in the 1969 International Convention on Tonnage Measurement of Ships, and which contains the total volume or allows for the direct mathematical determination of total volume). Vessels without such total volume information shall be inspected by Canal authorities who will determine an appropriate volume for use in the calculation of a PC/UMS Net Tonnage of such vessels.

**§ 135.3 Determination of total volume.**

(a) The determination of total volume used in the calculation of PC/UMS Net Tonnage shall be carried out by the Panama Canal Commission. In so doing, however, the Commission may rely upon total volume information provided by such officials as are authorized by national governments to undertake surveys and issue national tonnage certificates. Total volume information presented at the Panama Canal shall be subject to verification, and if necessary, correction insofar as may be necessary to ensure accuracy to a degree acceptable to the Panama Canal Commission.

(b) The Commission may, when it is deemed necessary to verify information contained on the ITC 69, require the submission of additional documents. Failure to submit the requested documentation may result in the Commission's developing a figure that accurately reflects the vessel's volume.

**§ 135.4 Administration and interpretation of rules.**

The rules of measurement provided in this part shall be administered and interpreted by the Administrator of the Panama Canal Commission.

**Subpart B—PC/UMS Net Tonnage Measurement**

**§ 135.11 Tonnage.**

(a) The tonnage of a ship shall consist of PC/UMS Net Tonnage.

(b) The net tonnage shall be determined in accordance with the provisions of the regulations in this subpart.

(c) The net tonnage of novel types of craft whose constructional features are such as to render the application of the provisions of the regulations in this subpart unreasonable or impracticable shall be determined in a manner which is acceptable to the Panama Canal Commission.

**§ 135.12 Definitions.**

(a) *Upper Deck* means the uppermost complete deck exposed to weather and sea, which has permanent means of weathertight closing of all openings in the weather part thereof, and below which all openings in the sides of the ship are fitted with permanent means of watertight closing. In a ship having a stepped upper deck, the lowest line of the exposed deck and the continuation of that line parallel to the upper part of the deck is taken as the upper deck.

(b) *Moulded Depth* means the vertical distance measured from the top of the keel to the underside of the upper deck at side.

(1) In wood and composite ships the distance is measured from the lower edge of the keel rabbet. Where the form at the lower part of the midship section is of a hollow character, or where thick garboards are fitted, the distance is measured from the point where the line of the flat of the bottom continued inwards cuts the side of the keel.

(2) In ships having rounded gunwales, the moulded depth shall be measured to the point of intersection of the moulded lines of the deck and side shell plating, the lines extending as though the gunwales were of angular design.

(3) Where the upper deck is stepped and the raised part of the deck extends over the point at which the moulded depth is to be determined, the moulded depth shall be measured to a line of reference extending from the lower part of the deck along a line parallel with the raised part.

(c) *Breadth or moulded breadth* means the maximum breadth of the ship, measured amidships to the moulded line of the frame in a ship with a metal shell and to the outer surface of the hull in a ship with a shell of any other material.

(d) *Enclosed spaces* mean all spaces which are bounded by the ship's hull, by fixed or portable partitions or

bulkheads, by decks or coverings other than permanent or movable awnings. No break in a deck, nor any opening in the ship's hull, in a deck or in a covering of a space, or in the partitions or bulkheads of a space, nor the absence of a partition or bulkhead, shall preclude a space from being included in the enclosed space.

(e) *Excluded spaces* mean, notwithstanding the provisions of paragraph (d) of this section, the spaces referred to in paragraphs (e)(1) to (e)(5) of this section. Excluded spaces shall not be included in the volume of enclosed spaces, except that any such space which fulfills at least one of the following three conditions shall be treated as an enclosed space:

- The space is fitted with shelves or other means for securing cargo or stores;
- The openings are fitted with any means of closure;
- The construction provides any possibility of such openings being closed.

(1)(i) A space within an erection opposite an end opening extending from deck to deck except for a curtain plate of a depth not exceeding by more than 25 millimeters (one inch) the depth of the adjoining deck beams, such opening having a breadth equal to or greater than 90 percent of the breadth of the deck at the line of the opening of the space. This provision shall be applied so as to exclude from the enclosed spaces only

the space between the actual end opening and a line drawn parallel to the line or face of the opening at a distance from the opening equal to one-half of the width of the deck at the line of the opening (Figure 1).

In the figure:

O = excluded space

C = enclosed space

I = space to be considered as an enclosed space

Hatched in parts to be included as enclosed spaces.

B = breadth of the deck in way of the opening.

In ships with rounded gunwales the breadth is measured as indicated in Figure 11 in paragraph (e)(5).

BILLING CODE 3640-04-P

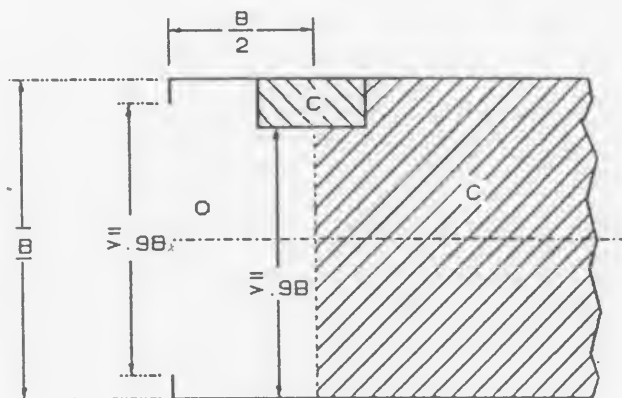

Fig. 1

BILLING CODE 3640-04-C

(1)(ii) Should the width of the space because of any arrangement except by convergence of the outside plating, become less than 90 percent of the breadth of the deck, only the space between the line of the opening and a parallel line drawn through the point where the athwartships width of the

space becomes equal to, or less than, 90 percent of the breadth of the deck shall be excluded from the volume of enclosed spaces. (Figures 2, 3 and 4).

In the figures:

O = excluded space

C = enclosed space

I = space to be considered as an enclosed space

Hatched in parts to be included as enclosed spaces.

B = breadth of the deck in way of the opening.

In ships with rounded gunwales the breadth is measured as indicated in Figure 11 in paragraph (e)(5).

BILLING CODE 3640-04-P

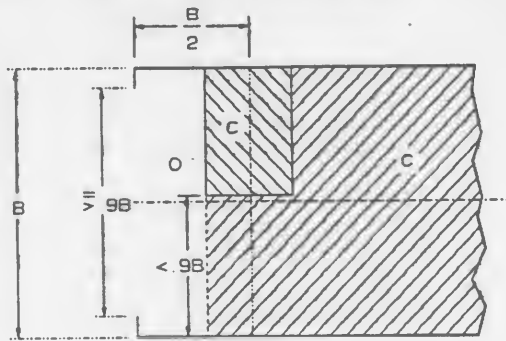

Fig. 2

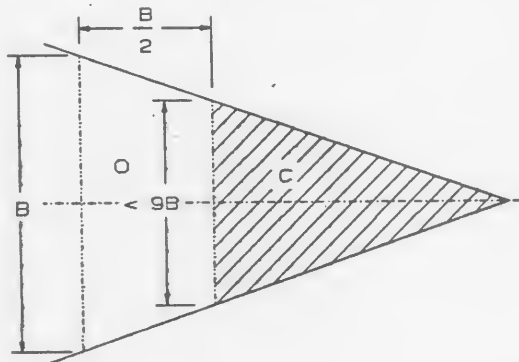

Fig. 3

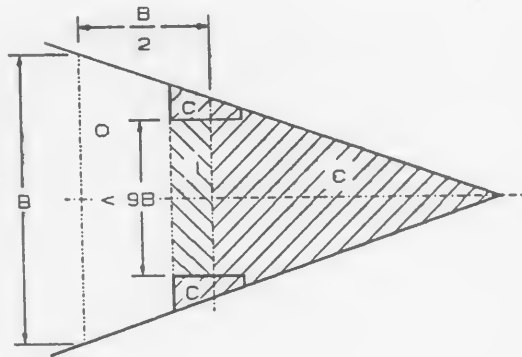

Fig 4



(1)(iii) Where an interval which is completely open except for bulwarks or open rails separates any two spaces, the exclusion of one or both of which is permitted under paragraphs (e)(1)(i) and/or (e)(1)(ii) of this section, such exclusion shall not apply if the separation between the two spaces is

less than the least half breadth of the deck in way of the separation. (Figures 5 and 6).

In the figures:

O = excluded space

C = enclosed space

I = space to be considered as an enclosed space

Hatched in parts to be included as enclosed spaces.

B = breadth of the deck in way of the opening.

In ships with rounded gunwales the breadth is measured as indicated in Figure 11 in paragraph (e)(5).

BILLING CODE 3640-04-P

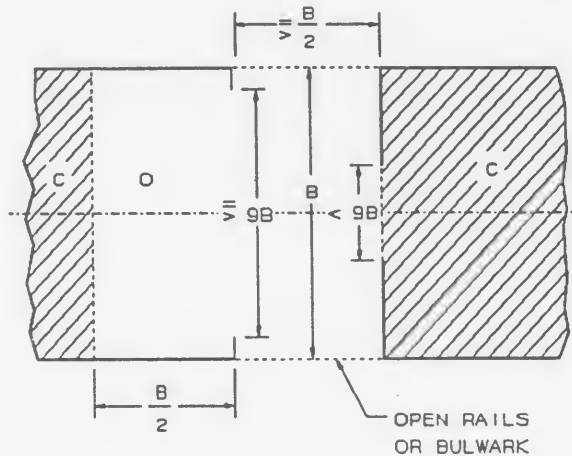

Fig. 5

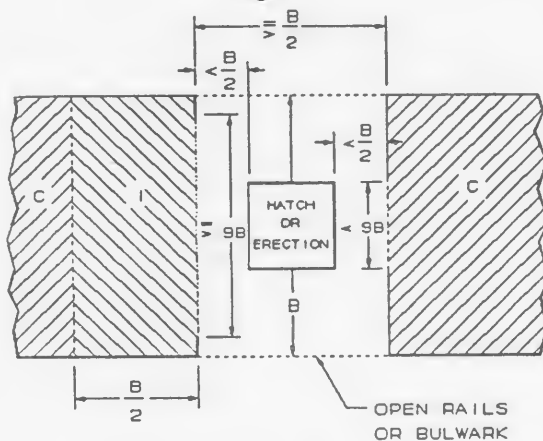

FIG. 6

BILLING CODE 3640-04-C

(2) A space under an overhead deck covering open to the sea and weather, having no other connection on the exposed sides with the body of the ship than the stanchions necessary for its

support. In such a space, open rails or a bulwark and curtain plate may be fitted or stanchions fitted at the ship's side, provided that the distance between the top of the rails or the bulwark and

the curtain plate is not less than 0.75 meters (2.5 feet) or one-third of the height of the space, whichever is the greater. (Figure 7).

BILLING CODE 3640-04-P

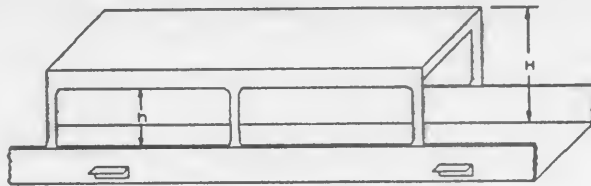

FIG. 7

$h = \text{AT LEAST } \frac{H}{3} \text{ OR } 0.75 \text{ m (2.5 FEET)}$   
WHICHEVER IS THE GREATER

BILLING CODE 3640-04-C

(3) A space in a side-to-side erection directly in way of opposite side openings not less in height than 0.75 meters (2.5 feet) or one-third of the height of the erection, whichever is the greater. If the opening in such an erection is provided on one side only, the space to be excluded from the

volume of enclosed spaces shall be limited inboard from the opening to a maximum of one-half of the breadth of the deck in way of the opening. (Figure 8).

In the figures:  
O = excluded space  
C = enclosed space  
I = space to be considered as an

enclosed space  
Hatched in parts to be included as enclosed spaces.  
B = breadth of the deck in way of the opening.  
In ships with rounded gunwales the breadth is measured as indicated in Figure 11 in paragraph (e)(5).

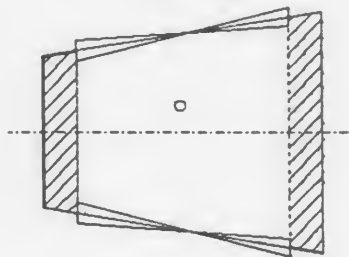
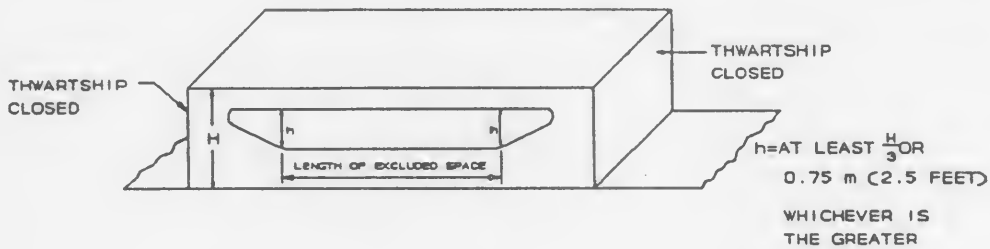

OPPOSITE SIDE OPENINGS

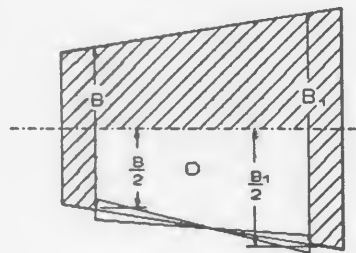

OPENING ON ONE SIDE ONLY

FIG. 8

BILLING CODE 3640-04-C

(4) A space in an erection immediately below an uncovered opening in the deck overhead, provided that such an opening is exposed to the

weather and the space excluded from enclosed spaces is limited to the area of the opening. (Figure 9).

BILLING CODE 3640-04-P

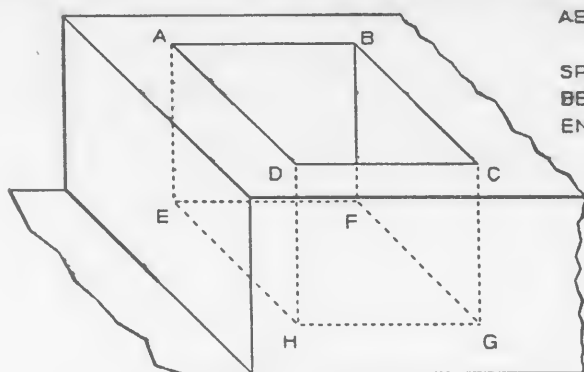

ABCD=OPENING IN THE DECK

SPACE ABCDEFGH SHALL  
BE EXCLUDED FROM  
ENCLOSED SPACE

Fig. 9

BILLING CODE 3640-04-P

(5) A recess in the boundary bulkhead of an erection which is exposed to the weather and the opening of which extends from deck to deck without means of closing, provided that the interior width is not greater than the

width at the entrance and its extension into the erection is not greater than twice the width of its entrance. (Figure 10).

In the figure:  
O = excluded space  
C = enclosed space

I = space to be considered as an enclosed space  
Hatched in parts to be included as enclosed spaces.

BILLING CODE 3640-04-P

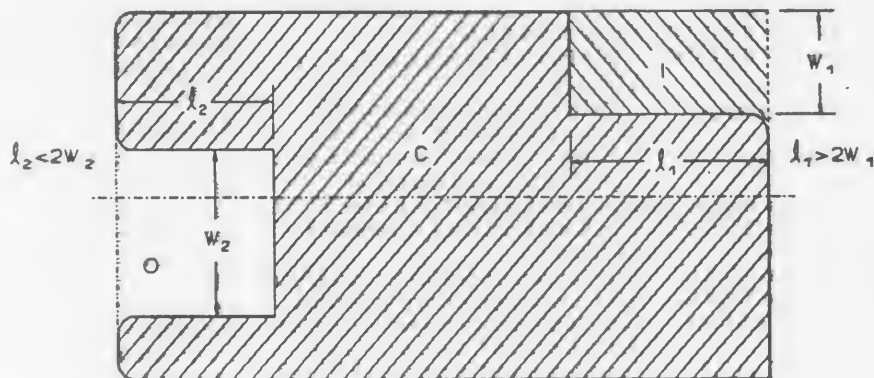

Fig 10

## SHIPS WITH ROUNDED GUNWALES

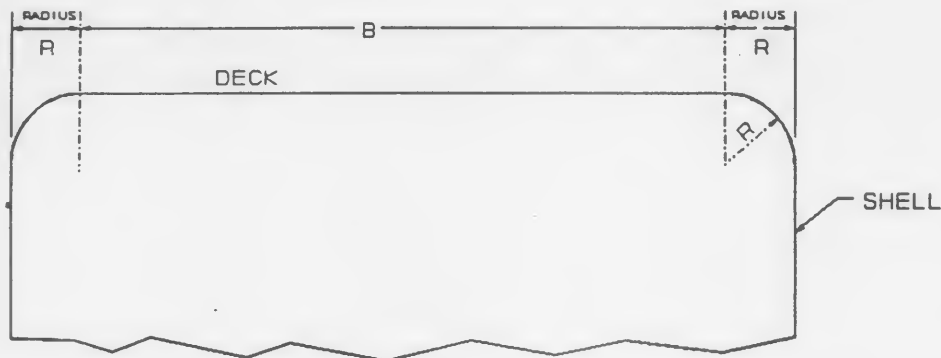

Fig. 11

## BILLING CODE 3640-04-C

(f) *Passenger* means every person other than:

(1) The master and the members of the crew or other persons employed or engaged in any capacity on board a ship on the business of that ship; and

(2) A child under one year of age.

(g) *Weathertight* means that in any sea conditions water will not penetrate into the ship.

#### § 135.13 Determination of PC/UMS net tonnage.

PC/UMS Net Tonnage will be determined as follows:

(a) For all vessels with tolls fixed in accordance with § 133.1 (a) or (b) of this chapter, unless eligible for the transitional relief measures established in § 135.31 of this chapter, the formula for determining PC/UMS Net Tonnage is:

PC/UMS Net Tonnage =  $K_4(V) + K_5(V)$   
in which formula:

(1) " $K_4$ " =  $[0.25 + (0.01 \times \text{Log}_{10}(V))]$   
 $\times 0.830$

(2) " $K_5$ " =  $[\text{Log}_{10}(\text{DA}-19)] / \{[\text{Log}_{10}(\text{DA}-16)] \times 17\}$ . If the number of passengers ( $N_1 + N_2$ ) is greater than 100 or DA is equal to or less than 20.0 meters then  $K_5$  is equal to zero.

(3) " $V$ " = Total volume of all enclosed spaces of the ship in cubic meters and is identical to  $V$  as specified in the 1969 International Convention on Tonnage Measurement of Ships.

(4) " $\text{DA}$ " (Average depth) = The result of the division of the Total Volume by the product of the length in meters multiplied by the molded breadth in meters.  $\text{DA} = V/(L \times \text{MB})$ .

(5) " $L$ " (Length) is defined as 96 percent of the total length on a waterline

at 85 percent of the least moulded depth measured from the top of the keel, or the length from the fore side of the stem to the axis of the rudder stock on that waterline, if that be greater. In ships designed with a rake of keel, the waterline on which this length is measured shall be parallel to the designed waterline.

(6) Moulded breadth is defined in § 135.12(c).

(7)  $N_1$  = number of passengers in cabins with not more than 8 berths.

(8)  $N_2$  = number of other passengers.

(9)  $N_1 + N_2$  = total number of passengers the ship is permitted to carry as indicated in the ship's passenger certificate.

(b) For vessels eligible for transitional relief measures, the existing Panama Canal Net Tonnage as specified on the certificate issued by Panama Canal Commission will become the PC/UMS Net Tonnage. In such case, the formula for determining PC/UMS Net Tonnage is: PC/UMS Net Tonnage = Panama Canal Net Tonnage.

#### § 135.14 Change of PC/UMS net tonnage.

(a) Vessels whose PC/UMS Net Tonnage is determined in accordance with section § 135.13(a) will have a new PC/UMS Net Tonnage issued if " $V$ " changes.

(b) A vessel whose PC/UMS Net Tonnage is determined in accordance with § 135.13(b) will retain that tonnage until the vessel undergoes a significant structural change as defined in § 135.14(c). In the event of a significant structural change, the vessel's PC/UMS Net Tonnage will be determined in accordance with § 135.13(a).

(c) For the purposes of paragraph (b), significant structural change means an actual change of at least 10 percent in the total volume of the vessel. Vessels without comparative ITC 69 total volumes, or other suitable sources of total volume comparison, will have a fair and equitable volume comparison made by the Commission to determine if a significant structural change has occurred.

#### § 135.15 Calculation of volumes.

(a) All volumes included in the calculation of PC/UMS net tonnage shall be measured, irrespective of the fitting of insulation or the like, to the inner side of the shell or structural boundary plating in ships constructed of metal, and to the outer surface of the shell or to the inner side of structural boundary surfaces in ships constructed of any other material.

(b) Volumes of appendages shall be included in the total volume.

(c) Volumes of spaces open to the sea may be excluded from the total volume.

#### § 135.16 Measurement and calculation.

(a) All measurements used in the calculation of volumes shall be taken to the nearest centimeter or one-twentieth of a foot.

(b) The volumes shall be calculated by generally accepted methods for the space concerned and with an accuracy acceptable to the Commission.

(c) The calculation shall be sufficiently detailed to permit easy checking.

**Subpart C—Warships, Dredges and Floating Drydocks****§ 135.21 Warships, dredges and floating drydocks to present documents stating displacement tonnage.**

All warships, floating drydocks, and dredges shall present documents stating accurately the tonnage of displacement at each possible mean draft. The term "warship" means any vessel of government ownership that is being employed by its owners for military or naval purposes and shall include armed coast guard vessels and vessels devoted to naval training purposes, but shall not include naval auxiliary vessels such as tankers, ammunition ships, refrigerator ships, repair ships, tenders or vessels used to transport general military supplies.

**§ 135.22 Tolls on warships, dredges and floating drydocks levied on actual displacement.**

The toll on warships, dredges, and floating drydocks shall be based upon their tonnage of actual displacement at the time of their application for passage through the Canal. The actual displacement of these vessels shall be determined in a manner acceptable to the Commission and shall be expressed in tons of 2240 pounds. Should any of these vessels not have on board documents from which the displacement can be determined, Commission officials may use any practicable method to determine the displacement tonnage for assessment of tolls.

**Subpart D—Transitional Relief Measures****§ 135.31 Vessels eligible for transitional relief measures.**

To be eligible for the transitional relief measures as specified in § 135.13(b), a vessel must have made a transit of the Panama Canal between March 23, 1976 and September 30, 1994, inclusive, and not have had a significant structural change as defined in § 135.14(c) since the last transit during the above period. Any significant structural change made after the granting of transitional relief measures will disqualify a vessel for further relief, and the vessel will be handled in accordance with the provisions of § 135.13(a). Transitional relief measures are applied to the vessel during its entire active service life as long as the vessel does not undergo a significant structural change. Vessels eligible for transitional relief measures will present their existing Panama Canal Tonnage Certificate on their first transit after October 1, 1994. Vessels eligible for

relief measures will not be required to present an ITC 69 or any other total volume certification.

**Subpart E—Alternative Method for Measurement of Vessels****§ 135.41 Measurement of vessels when volume information is not available.**

When an ITC 69 or suitable substitute is not presented or the certificate or substitute presented does not have an accuracy acceptable to the Commission, vessels will be measured in a manner that will include the entire cubical contents as required by the definition of total volume and enclosed spaces. The Commission will endeavor to determine an accurate total volume of the vessel using the best information available at the time of the determination. The total volume shall be calculated by generally accepted methods for the space concerned and with an accuracy acceptable to the Commission.

**§ 135.42 Measurement of ships when tonnage cannot be otherwise ascertained.**

(a) Vessels without an ITC 69, a suitable substitute or documentation from which to calculate total volume shall be measured as follows.

(1) The volume of structures above the upper deck may be determined by any accepted method or combination of methods. These methods include but are not limited to simple geometric formulas, Simpson's rules, and other standard mathematical formulas. If special procedures are used, they should be identified. In all cases, measurements and calculations should be sufficiently detailed to permit easy review.

(2) The volume of the hull below the upper deck (UDV) shall be determined as follows:

(i) The formula:

$$UDV = (0.91 \times ((LOA \times MB) \times (D - SLD))) + (SLDISP/1.025)$$

Where:

UDV = Total volume of all enclosed spaces below the upper deck in cubic meters.

LOA = The Length overall, i.e., the length of the ship in meters from the foremost to the aftermost points, including a bulbous bow if present.

MB = Moulded breadth in meters as defined in § 135.12(c).

D = Moulded depth in meters as defined in § 135.12(b).

SLD = Summer loaded draft (in meters) i.e., the maximum depth to which the vessel's hull may be immersed when in a summer zone.

SLDISP = Summer loaded displacement, i.e., the actual weight in metric tons of the water displaced by the vessel when immersed to her SLD.

(ii) If § 135.42(a)(2)(i) proves unworkable, the total volume of the hull below the upper deck will be determined by multiplying the product of the LOA, MD and D by the appropriate coefficient listed in the following table:

LOA in meters	Coefficient
0 to 30 .....	.7150
> 30 to 60 .....	.7250
> 60 to 90 .....	.7360
> 90 to 120 .....	.7453
> 120 to 150 .....	.7328
> 150 to 180 .....	.7870
> 180 to 210 .....	.8202
> 210 to 240 .....	.7870
> 240 to 270 .....	.7328
> 270 .....	.7453

(3) The total volume of a vessel is the sum of the volume of the structures above the upper deck as determined in accordance with § 135.42(a)(1) and the volume of the hull below the upper deck as determined in accordance with § 135.42(a)(2)(i) or (ii).

(b) Vessels which have had their total volume determined in accordance with § 135.41 or this section may apply for readmeasurement when they have a new or corrected ITC 69, a suitable substitute or present documentation sufficient to calculate total volume.

Dated: April 6, 1994.

Gilberto Guardia F.,

Administrator, Panama Canal Commission.

[FRC Doc. 94-9301 Filed 4-15-94; 8:45 am]

BILLING CODE 3640-04-P

**ENVIRONMENTAL PROTECTION AGENCY****40 CFR Part 52**

[UT4-1-5628 and UT2-1-5441; FRL-4875-1]

**Approval and Promulgation of State Implementation Plans; Utah Stack Height Analyses and Regulations**

AGENCY: Environmental Protection Agency (EPA).

ACTION: Proposed rule.

**SUMMARY:** The Governor of Utah submitted two revisions to the Utah State Implementation Plan (SIP): Section 16, Stack Height Demonstration, and Section 9, Part B, Sulfur Dioxide. Sections 16 and 9 were submitted in letters dated December 23, 1991, and May 15, 1992, respectively. The revisions to Section 16 were to address the stack-height demonstration requirements for the Kennecott Minerals Company Smelter near Magna, Utah. Minor corrections to the other stacks in

the State were also made. Section 9, Part B was revised to be consistent with Section 16. Prior to the revision, the SO<sub>2</sub> attainment demonstration for Salt Lake County and portions of Tooele County was based on multipoint rollback emission rates at the Kennecott smelter. The PM<sub>10</sub> SIP adopted for Salt Lake County in 1991 established significantly lower emission rates (which would meet the 24-hour National Ambient Air Quality Standard (NAAQS) for the smelter based on reasonable available control technology (RACT). Section 16 and Section 9, Part B needed to be consistent with the PM<sub>10</sub> SIP (the PM<sub>10</sub> SIP is located in Section 9, Part A). In addition, Section 9 Part B was revised to include an analysis and the emission limitation that would demonstrate attainment of the 3-hour secondary NAAQS.

**DATES:** Comments must be received on or before May 18, 1994.

**ADDRESSES:** Written comments should be addressed to: Douglas Skie (ART—AP) Air Programs Branch, EPA Region VIII, 999 18th St., suite 500, Denver, Colorado 80202-2466.

Copies of the documents relevant to this proposed action are available for public inspection between 8 a.m. and 4 p.m., Monday through Friday, at the following office: Environmental Protection Agency, Region VIII, Air Programs Branch, 999-18th Street, suite 500, Denver, Colorado 80202-2466.

**FOR FURTHER INFORMATION CONTACT:** Lee Hanley, Air Programs Branch, Environmental Protection Agency, Region VIII, 999-18th Street, suite 500, Denver, Colorado 80202-2466, (303) 293-1760.

#### SUPPLEMENTARY INFORMATION:

##### I. Background

###### A. Regulatory History

On February 8, 1982 (47 FR 5864), EPA promulgated final regulations limiting stack height credits and other dispersion techniques as required by section 123 of the Clean Air Act (CAA). These regulations were challenged in the U.S. Court of Appeals for the D.C. Circuit by the Sierra Club Legal Defense Fund, Inc., the Natural Resources Defense Council, Inc., and the Commonwealth of Pennsylvania in *Sierra Club v. EPA*, 719 F.2d 436 (DC Cir. 1983). On October 11, 1983, the court issued its decision ordering EPA to reconsider portions of the stack height regulations, while upholding other portions. As a result, EPA promulgated revisions to the stack height regulations on July 8, 1985 (50 FR 27892). The revisions redefined a

number of specific terms including "excessive concentrations," "dispersion techniques," "nearby," and other important concepts, and modified some of the bases for determining good engineering practice (GEP) stack height credit.

Pursuant to Section 406(d)(2) as amended in the 1977 CAA, each state was required to: (1) Review and revise its SIP, as necessary, to include provisions that limit stack height credit and other dispersion techniques in accordance with the revised regulations; and (2) review all existing emission limitations to determine whether any of these limitations have been affected by stack height credits greater than GEP, or any other dispersion techniques. For any limitations so affected, each state was to prepare revised limitations consistent with the revised stack height regulation.

Subsequently, EPA issued detailed guidance on carrying out the necessary reviews. For the review of emission limitations, each state was to prepare an inventory of stacks greater than 65 meters in height and sources with emissions of sulfur dioxide (SO<sub>2</sub>) in excess of 5,000 tons per year (tpy). These limits correspond with the *de minimis* stack height and the *de minimis* SO<sub>2</sub> emission level provisions in the regulations. These sources were then subjected to detailed review for conformance with the revised federal regulations. State submissions were to contain an evaluation of each stack and source in the inventory.

Subsequent to the July 8, 1985 promulgation, the stack height regulations were again challenged in *NRDC v. Thomas*, 838 F.2d 1224 (D.C. Cir. 1988). On January 22, 1988, the U.S. Court of Appeals for the D.C. Circuit issued its decision affirming the regulations, for the most part, but remanding three provisions to the EPA for reconsideration. These are:

1. Grandfathering pre-October 11, 1983 within-formula stack height increases from demonstration requirements [40 CFR 51.100(kk)(2)];
2. Dispersion credit for sources originally designed and constructed with merged or multiflue stacks [40 CFR 51.100(hh)(2)(ii)(A)]; and
3. Grandfathering pre-1979 use of the refined H + 1.5L formula [40 CFR 51.100(ii)(2)].

However, none of these provisions is at issue here.

###### B. Regulatory Requirement for Stacks Greater Than GEP

GEP has been established by the regulations to be the greater of: (1) 65 meters, (2) the height derived through application of one of two formulas

which base GEP on the dimensions of nearby buildings, or (3) the height demonstration through a field study or fluid modeling demonstration to be necessary to avoid excessive concentrations of any air pollutant due to downwash, eddies, or wakes caused by the source itself or nearby buildings or terrain obstacles (40 CFR 51.100(ii)). Where EPA or a State finds that a source emission limit is affected by dispersion from a stack in excess of GEP, the State must then model to establish an emission limit which will provide for attainment of the NAAQS when stack height credit is restricted to GEP.

The term "excessive concentration" is defined in the regulations to be a 40% increase in concentrations of an air pollutant due to downwash which also results in an exceedance of an applicable NAAQS or prevention of significant deterioration (PSD) increment. In order to demonstrate that stack height in excess of the GEP formulas is needed, a source owner must show through the use of fluid modeling that, when meeting emission rates equivalent to the new source performance standard applicable to the source category, excessive concentrations would result from the use of a shorter stack height. However, a source may demonstrate that the NSPS emission limit is infeasible, establishing an alternative emission limit that represents the most stringent degree of emissions control feasible for the particular source. In making this demonstration, source owners may generally rely on EPA's Guidelines for the Determination of Best Available Retrofit Technology for Coal-Fired Power Plants and Other Existing Stationary Facilities, EPA 450/3-80-009b, November 1980 (BART Guideline).

###### C. The 1981 and 1986 SIP Submittals

###### 1. The 1981 SO<sub>2</sub> SIP Submittal

A Utah SO<sub>2</sub> SIP revision was submitted with a letter dated August 17, 1981, by the Governor of Utah to address the attainment of the SO<sub>2</sub> NAAQS in Salt Lake County and portions of the nonattainment area in Tooele County. Additional information was submitted by the State on December 7, 1981 and January 25, 1983. On February 7, 1983, the Governor submitted a request to redesignate all of Salt Lake County and the nonattainment portion of Tooele County to attainment. On March 23, 1984 (49 FR 10926), EPA proposed to delay any action on the request to redesignate the area to attainment until final resolution of several issues. A detailed discussion of

this SIP revision is contained in the March 23, 1984 Notice of Proposed Rulemaking and should be used as a reference for additional information.

This SIP revision contained several complex national issues, such as what constitutes ambient air and whether attainment demonstration is sufficient without dispersion modeling or monitoring. Section 50.1 of Title 40 Code of Federal Regulations (CFR) defines "ambient air" simply as "that portion of the atmosphere, external to buildings, to which the general public has access." Application of that regulatory provision is based on an evaluation of where public lands are involved, where private lands are subject to little restriction on access, or conversely, where lands adjacent to a source are clearly restricted for the public. Kennecott has maintained for some years, that public access to the property (and therefore, the atmosphere) in question has been and is precluded. The cumulative effect of Kennecott's property holding, property exchanges, installation of fences, posts, no-trespassing signs, and security patrolling, supports the Company's claim to control use of the relevant property. There was information on termination of limited elk hunting practices in the area. Kennecott's man-made barriers, and other security measures, together with the inherently rugged nature of the mountainous terrain involved, were believed to effectively preclude access.

The control strategy for the 1981 SIP has several parts: (1) Emission limitations on several low-level stacks at the smelter (e.g., boilers and heat treaters); (2) reasonably available measures to control or eliminate fugitive emissions; and (3) cumulative emission limits for the main stack (see additional discussion on these emission limits in 2.b. below). The State's strategy was based upon measured ambient data in the lower elevation near the smelter. EPA identified the major deficiencies of the State analysis: (1) The State made no attempt to demonstrate the effects in the upper elevation (above 5600 feet in the Oquirrh Mountains); and (2) the database at the smelter was insufficient to be used reliably with the established emission limits, given the assumption in the development of the emission limits technique. Modeling analyses performed by the State and EPA to demonstrate attainment in the upper elevation were screening analyses only. EPA concluded that dispersion modeling in this complex terrain was unreliable and that the only method that could be used for this determination was monitoring. The 1981 SO<sub>2</sub> SIP was

conditionally approved on the assumption that the emission limits were consistent with federal 1985 stack height rules and, therefore, adequate for attainment of the SO<sub>2</sub> NAAQS. The redesignation of the area to attainment was denied. (50 FR 7059, February 20, 1985)

## 2. The May 2, 1986 GEP SIP Submittal

The Utah Stack Height SIP was submitted by the Governor with a letter dated May 2, 1986. The submittal included regulations to address (1) GEP stack height credit and dispersion techniques, (2) a new Section 17 of the SIP that listed all existing stacks in Utah greater than 65 meters, and (3) a technical support document for Section 17 of the SIP. The Kennecott Magna stack analyses were part of this submittal. Subsequent submittals to support the Kennecott analyses were received in letters dated October 6, 1986, December 3, 1986, November 13, 1987, and May 17, 1988.

The Kennecott smelter stack height credit was a significant component of the Utah SO<sub>2</sub> SIP emission limits conditionally approved on February 20, 1985. Briefly, a condition in that approval required the State to determine whether the 1215-foot stack would be GEP once the revised stack height regulations were promulgated. If not, the emission limits would then be revised as necessary.

a. *Applicability of the NSPS Regulation.* The federal NSPS regulation for primary copper smelters applies to any such facility that commences construction or modification after October 16, 1974 (42 FR 37937, July 25, 1977 and 40 CFR 60.160). Modification generally means any physical or operational change which results in an increase in the emission rate to the atmosphere. NSPS require, among other things, control of the strong gas streams with a double contact acid plant (i.e., a stack gas of 650 ppm or less SO<sub>2</sub>, based on a 6-hour average (EPA 450/3-83-018a)).

The Kennecott Magna smelter expansion/modification began in the early 1970s, with a commitment to the 1215-foot stack in 1973 and completion of the project in 1977. The modification of the acid plant system resulted in an increase from 60% sulfur capture to 86%, approximately a 65% reduction of sulfur emissions. Based on this information, EPA concluded that the 1970's Kennecott expansion/modification did not subject the smelter to NSPS requirements.

b. *Analyses on the 1986 Submittal.* The Kennecott stack height analyses were undertaken to comply with the

July 8, 1985 stack height regulation, as well as the condition specified in the approval of the Utah SO<sub>2</sub> SIP. The reader should refer to the February 2, 1985 final conditional approval (50 FR 7056) and March 23, 1984 proposed approval (49 FR 10946) Federal Register actions for additional information on the Utah SO<sub>2</sub> SIP.

Kennecott originally had two 400-foot stacks (grandfathered stack heights) from which SO<sub>2</sub> emissions from the smelter were vented. The 1970's modification/expansion included the replacement of the 400-foot stacks with a single 1215-foot stack. The GEP formula height (H+1.5 L), considering the nearby buildings, is 212.5 feet. The federal regulation established the policy that sources faced with excessive concentrations, due to downwash, should be required to attempt to reduce those concentrations by reducing emissions to the degree feasible before seeking credit above the GEP formula. The benchmark for this requirement is the NSPS or the alternative level of control established through the application of BART if the NSPS is found to be infeasible. The demonstration that the NSPS is infeasible can be done through a fluid modeling analyses.

The initial Kennecott GEP demonstration was submitted on May 2, 1986, with subsequent submittals on October 6, 1986, December 3, 1986, November 13, 1987, and May 11, 1988. There are two basic parts to the Kennecott analyses: the GEP demonstration and BART analysis. The GEP demonstration consists of three subparts: the fluid modeling protocol, the fluid modeling results, and an evaluation of the fluid modeling results with respect to the stack height regulations. The BART analysis is performed if the source contends that the NSPS emission limits are infeasible. Relevant factors for this analysis include: high cost-effectiveness ratio, excessive local community impact, excessive plant impact, and technological infeasibility.

Since the Kennecott emissions, as established through Multi-point Rollback (MPR), were used in the 1981 SO<sub>2</sub> SIP, EPA's primary concern, with the use of any emission rate in the demonstration of GEP, is ensuring protection of the NAAQS (i.e., to protect health and welfare). The basic concept behind GEP is to prevent sources from using illegal dispersion techniques to avoid emissions controls.

Kennecott provided extensive data on its GEP analyses. The reader is referred to 53 FR 48942 for information on the GEP demonstration and BART analysis.

To summarize, the GEP demonstration showed that the existing stack height of 1215-foot (370.4m) met the 40% criterion due to terrain effects and an exceedance of the NAAQS at MPR emission rates. (Discussion of the MPR emission rates for Kennecott can be found in 49 FR 10948, March 12, 1983, proposed rulemaking). MPR is a technique designed for sources with variable emission rates (e.g., smelters). MPR allows for a frequency distribution of emission rates which will permit extremely high emissions on rare occasions. The MPR methodology is constructed around the recognition that any control strategy will have a predictable probability of allowing a violation of the NAAQS. The MPR is based upon allowing a 26% probability of recording a violation (Additional information on MPR is found in Appendix A). The GEP demonstration satisfies the excessive concentration criteria in EPA's regulation if MPR reflects the proper emission rates. After review, EPA concluded that Kennecott's analyses were acceptable, since Kennecott performed a fluid modeling study consistent with existing guidance and the study was approved by EPA.

The purpose of establishing a BART emission rate in the 1985 stack height regulations was to prevent source owners from using unreasonably high emission rates to justify credit for excessive stack heights. The regulation requires that sources faced with excessive concentrations due to downwash should be required to attempt to reduce those concentrations by reducing those emissions to the degree feasible before seeking credit above the GEP formula. The benchmark for this requirement is the NSPS, or an alternative level of control established through the application of BART if NSPS is found to be infeasible. Kennecott provided responses to all the BART factors mentioned above. The cost-effectiveness ratio and technical infeasibility issues, however, were determined critical to this review because of their relationship to the emission limitations used in the GEP analyses.

Application of the level of control required by NSPS would reduce the emissions of SO<sub>2</sub> at Kennecott during the stable process phase, but would not affect emission rates under startup, shutdown, malfunction, and upset conditions. This is because the NSPS emission rate is for normal operations and excludes such process conditions. MPR includes startup, shutdown, malfunction, and upset conditions. From the Kennecott assessment, considering only long-term averages, the

cost portion is consistent with the tons of SO<sub>2</sub> reduction expected from similar NSPS applications. In the Kennecott BART analysis, the controlling emissions for the determination of GEP appear to be those under upset, start-up, shutdown, and malfunction. Therefore, while there would be no difference in the emission rates under these conditions as a result of meeting NSPS, there would be a substantial additional cost to control these emissions.

In summary, the emissions at the smelter from startups, shutdowns, upsets, and malfunctions are included in the MPR emission limits and could be considered in the NAAQS attainment and GEP analyses. Application of NSPS technology will not affect these emission rates and will, therefore, result in no change in demonstrating GEP. It may be possible to reduce annual emissions by requiring additional controls on the smelter, but such reduction would have no relevance to the limiting case for determination of GEP.

Given the above discussion, EPA proposed to approve (53 FR 48942, December 5, 1988) the Kennecott analysis in the Utah GEP SIP submitted on May 2, 1986, with subsequent submittals on October 6, 1986, December 3, 1986, November 13, 1987, and May 17, 1988. However, EPA's review was conducted under a specific assumption: that the emission rate(s) in the SO<sub>2</sub> SIP were sufficient to demonstrate attainment. That assumption followed another critical assumption: that Kennecott owned or controlled the lands in the upper elevation for which no monitoring data exist to demonstrate attainment of the NAAQS.

Only one comment was received in response to the December 5, 1988 Federal Register proposed approval of the Kennecott GEP demonstration. The comment was from Kennecott in support of this action. However, prior to publication of the proposed approval Federal Register, EPA did receive a letter from a landowner in the Oquirrh Mountains expressing concerns due to the lack of ambient monitoring in the nonattainment area. This was EPA's first documented information on public access in the nonattainment area other than the Kennecott operation. EPA proceeded to continue its evaluation of the State submittal and to publish its position on the GEP demonstration based on the State submittal, but initiated a reevaluation on land ownership above the 5600-ft. elevation in the Oquirrh Mountains. Documentation on the claim of land ownership, other than that of the

Kennecott operations, was provided by Howard Haynes, Jr. in March 1989.

### 3. Utah 1981 SO<sub>2</sub> and 1986 GEP SIP Reassessment

Data from the Salt Lake County and Tooele County Assessor offices showed over 80 landowners in this nonattainment area. Kennecott, in its land ownership research, verified the list of landowners.

As stated above, one of the critical assumptions of the conditional approval of the 1981 SO<sub>2</sub> SIP and the emission rate was Kennecott's ownership or control of those lands in the potential nonattainment area in the Oquirrh Mountains. The land ownership research revised the EPA's earlier assumptions on the adequacy of the 1981 SO<sub>2</sub> and the 1986 GEP Stack SIPs.

EPA entered into discussions with Kennecott and the State for resolution of these issues and attempted to outline the procedures for addressing the SO<sub>2</sub> and GEP SIPs. Documentation of these meetings and discussions is found in EPA letters to the State dated July 12, 1989, and August 14, 1989. Since monitoring has been stated as the only method to conclusively determine the attainment status of lands in the Oquirrh Mountain, the State and Kennecott proceeded to develop a monitoring program. Maximum ambient concentration location of the monitors, access to the monitors, and operational logistics of the monitor(s) were key problems identified.

During these negotiations, the State was developing the PM<sub>10</sub> SIP for Salt Lake County. The Salt Lake County PM<sub>10</sub> SIP development process identified SO<sub>2</sub> as a precursor for PM<sub>10</sub>. (Precursors are secondary particles which are formed in the atmosphere from gases which are directly emitted by the source. Sulfates are one of the most common secondary particles in a PM<sub>10</sub> nonattainment area and result from sulfur dioxide emissions.) The Kennecott smelter SO<sub>2</sub> emissions comprised ~56% of the total (primary and secondary) PM<sub>10</sub> emissions in Salt Lake County.

The PM<sub>10</sub> SIP was adopted by the State in August 1991 and submitted to EPA in November 1991. The reader is referred to 57 FR 60149, December 18, 1992, for information on the PM<sub>10</sub> SIP. The PM<sub>10</sub> SIP required significant emission reduction for the Kennecott operations (refinery, concentrator, mine, power plant and smelter). The Kennecott smelter emission limits were reduced from 76,000 tpy or 18,000 lb/hr annual average (as allowed in the 1981 SO<sub>2</sub> and 1986 GEP SIPs) to ~18,500 tpy (which includes fugitive emissions,



and applies to the entire smelter). (The 1981 SO<sub>2</sub> and 1986 GEP SIPs addressed emissions from smelter processing units and SO<sub>2</sub> collection and removal equipment vented to the smelter tall stack. They did not include fugitive emissions. For clarification, the 76,000 tpy was reduced to the 14,191 tpy limit on the 1215-foot stack for emissions from the smelter processing units and SO<sub>2</sub> collection and removal equipment).

**D. The 1991 GEP and 1992 SO<sub>2</sub> SIP Submittals**

Prior to the State's adoption of the PM<sub>10</sub> SIP, EPA discussed the uncertainties of finalizing the 1986 GEP SIP with the State and Kennecott. EPA clarified its position on the need for consistency within the Utah SIP with respect to emission limitations at the Kennecott smelter. In a letter dated July 18, 1991, EPA outlined the SIP Revisions that must occur to address the inconsistencies between the 1981 SO<sub>2</sub> SIP, the 1986 GEP SIP, and 1991 PM<sub>10</sub> SIP. To summarize, EPA stated that it could not knowingly and legally proceed to approve a regulation and emission limitation that were no longer applicable, or a stack height demonstration analysis based on an obsolete regulation or emissions limitation.

In a letter dated December 23, 1991, the Governor of Utah submitted a revision to Section 16, Demonstration of GEP Stack Height, of the Utah SIP. The 1991 submittal was received on December 30, 1991. On February 28, 1992, EPA advised the Governor of Utah that this submittal was administratively and technically complete in accordance with the Federal SIP completeness criteria.

The revisions to Section 16 specify the allowable emission limit for the 1215-foot main stack at 14,191 tons/year as derived in the PM<sub>10</sub> SIP. This emission limit is based on double contact acid plant technology (which is considered NSPS for the smelter acid plant tail gas), significant capture improvement of fugitive emissions, and improved operation and maintenance. The 1991 submittal also contained a reanalysis of other sources in the State for which stack heights above the de minimus level (65m) were previously reported. (These sources' stack heights were published in 54 FR 24334, June 7, 1989.)

EPA found minor changes between the June 7, 1989 Federal Register and the 1991 revision to Section 16 for the "actual" stack height of some sources. EPA is not concerned with these minor changes since they could be attributed to errors in rounding and the stack

height changes are less than one foot. Listed below are the differences between the June 7, 1989 Federal Register and the 1991 submittal:

Source	June 7, 1989 FR	1991 revision
Desert Units 1 and 2	182.9 m	182 m
UP&L Hunter Units 1 and 2.	183.08 m	183 m
UP&L Hunter Unit 3 ..	183.1 m	183 m <sup>1</sup>
UP&L Huntington Units 1 and 2. .	182.93 m	183 m
IPP Units 1 and 2 .....	216.46 m	216 m
Chevron USA HCC cracker.	1946 <sup>1</sup>	1950 <sup>2</sup>

<sup>1</sup>The State indicated very insignificant changes to these sources "calculated" GEP stack heights; the State has indicated that the "actual" height will be the enforceable stack height.

<sup>2</sup>Correction of grandfathered date.

The State's revised analyses are presented in the table below. Detailed documentation for these analyses and the corresponding EPA review is contained in the EPA technical support document and air compliance files, and the State files.

Source name	Stack height (M)	Allowable SO <sub>2</sub> emissions (ton/year)
Deseret Units 1&2	182	1,512
U.P.&L. Hunter Units 1&2 .....	183	4,347
U.P.&L. Hunter Unit 3 .....	183	1,283
U.P.&L. Huntington Units 1&2 .....	183	9,448
I.P.P. Units 1&2 ....	216	17,870
U.P.&L. Gadsby Units 1,2&3 .....	76.2	+67.7
Geneva Steel blast furnaces 1&2 ....	79.2	+*12.5
Geneva Steel Coke blast furnace .....	68.6	.....
Geneva Steel Coke Combustion 1-4 .....	76.2	+102.8
Kennecott Utah Copper Smelter Main Stack .....	370	+*14,191
Chevron USA HCC Cracker Cat. Dis .....	88.4	+66.7
Chevron Research Air Heater .....	69.8	0
Chevron Research Retort .....	69.8	+0
Amax melt reactor	76.22	0
Amax electrolytics	76.22	0
Amax emergency off gas .....	76.22	0
Amax spray dryers 1-3 .....	76.22	83
Phillips thermal cat. cracking .....	80.8	+3.5
White River Shale Lift Pipes .....	76.2	.....

Source name	Stack height (M)	Allowable SO <sub>2</sub> emissions (ton/year)
White River Elutriators .....	76.2	.....
White River Hydrogen Plant .....	76.2	.....
White River Power Plants .....	76.2	.....
White River Ball Heaters .....	76.2	*1,180.8
Tosco Preheat Stacks .....	95	-
Tosco Warm Ball Elutriators .....	95	-
Tosco Process Shale Wetters ...	95	*1,166.6

+ SO<sub>2</sub> emissions derived from the PM<sub>10</sub> SIP adopted August 14, 1991.

\*The total SO<sub>2</sub> emissions are given for these sources.

On May 15, 1992, the Governor of Utah submitted a revision to Section 9, Part B, Sulfur Dioxide, Utah SIP. The revision was to address the 1990 CAA requirement that a SIP revision be submitted by May 15, 1992, for any area that did not have a fully approved SIP (the 1981 SO<sub>2</sub> SIP was only conditionally approved). The significant change in this SIP revision from that of the 1981 submittal is as follows:

a. The MPR emission limitations and assumptions are removed and replaced with the emission limitation which can be achieved using the NSPS technology, double contact acid plant, or the equivalent of NSPS. (NSPS is the presumptive norm for RACT for this facility.) The SO<sub>2</sub> SIP now references the same emission limitations as those stated in PM<sub>10</sub> SIP.

b. The SO<sub>2</sub> NAAQS are the 0.14ppm, 24-hour primary standard, and the 0.5ppm, 3-hour secondary standard. The 24-hour impact analysis was a rollback analysis which compared the smelter emissions in 1991 (PM<sub>10</sub> SIP emission limitation) with 1979 emissions. The State had monitoring data showing attainment at Lake Point (an area originally defined as ambient air and owned by the Bureau of Land Management, but now owned by Kennecott) where exceedances were recorded. The Lake Point site could be considered representative of the closest point in the elevated terrain that would be impacted by the tall stack emissions. Demonstrating attainment at Lake Point would technically support the attainment elsewhere in the elevated terrain that is considered ambient air. The area considered ambient air in the elevated terrain is a significant distance downwind from Lake Point.

c. The PM<sub>10</sub> SIP addressed, to some degree, the 3-hour impact. The PM<sub>10</sub> SIP

emission limitation was based on a 24-hour SO<sub>2</sub> limit; this emission limitation would be achieved through a given lb/hr calculated on a 6-hour average. The 24-hour limit was considered "controlling" for PM<sub>10</sub> and SO<sub>2</sub> (i.e., the 24-hour limitation was believed to be the level of control necessary for PM<sub>10</sub> attainment, as well as for the SO<sub>2</sub> attainment demonstration). The SO<sub>2</sub> SIP established a 3-hour limitation and verified that such limitation would protect the 3-hour NAAQS.

d. Section 4.2 of the Utah Air Conservation Regulations was revised to include a 24-hour averaging period for the sulfur content of coal, fuel oil, and fuel mixtures, and to specify the ASTM methods to be used to demonstrate compliance with the limitation and reporting requirement. (The previous rule specified a limit for the sulfur content of fuels, but did not specify an averaging time or specific ASTM methods.) Section 4.6 was also revised to include a 3-hour averaging time for Sulfur Burning Production Sulfuric Acid Plants.

e. Specific regulations which provided for special consideration (including malfunction provisions) on the smelter fluctuating operation are removed. Malfunction provisions for the Kennecott smelter operation are now the same as for any stationary source in Utah. This issue was addressed during the PM<sub>10</sub> SIP development and is being approved under the PM<sub>10</sub> SIP federal approval process. These regulation impacts were clarified in this SIP revision.

## II. This Action

The December 23, 1991 Section 16, Stack Height revision and the May 15, 1992 Section 9, Part B, SO<sub>2</sub> revision are consistent with other provisions in the State-wide SIP. EPA is proposing to approve these revisions because they are consistent with EPA guidance for GEP stack height demonstration and the attainment demonstration for the SO<sub>2</sub> NAAQS.

These revisions resolve EPA's concerns regarding ambient air, attainment demonstration in the elevated terrain, and the enforceability issues related to the smelter operations. The previous emission limitations have been the subject of litigation filed by the Environmental Defense Fund. The legal actions have been stayed pending EPA final action on the past SIP revisions. The 1991 and 1992 revisions are believed to have settled the litigants' concerns about applying reasonable control technology and demonstrating attainment per the traditionally accepted federal requirements (i.e.,

application of RACT (double contact acid plant or the equivalent), monitoring demonstration, etc).

### Request for Public Comment

The EPA is requesting comments on all aspects of today's proposal. As indicated at the outset of this document, EPA will consider any comments received by May 18, 1994.

Nothing in this action should be construed as permitting or allowing or establishing a precedent for any future request for revision to any State Implementation Plan. Each request for revision to any State Implementation Plan shall be considered separately in light of specific technical, economic, and environmental factors and in relation to relevant statutory and regulatory requirements.

### Regulatory Flexibility

Under the Regulatory Flexibility Act, 5 U.S.C. 600 *et seq.*, EPA must prepare a regulatory flexibility analysis assessing the impact of any proposed or final rule on small entities. 5 U.S.C. 603 and 604. Alternatively, EPA may certify that the rule will not have a significant impact on a substantial number of small entities. Small entities include small businesses, small not-for-profit enterprises, and government entities with jurisdiction over population of less than 50,000.

SIP approvals under section 110 and subchapter I, part D of the CAA do not create any new requirements, but simply approve requirements that the State is already imposing. Therefore, because the federal SIP-approval does not impose any new requirements, I certify that it does not have a significant impact on any small entities affected. Moreover, due to the nature of the federal-state relationship under the CAA, preparation of a regulatory flexibility analysis would constitute federal inquiry into the economic reasonableness of state action. The CAA forbids EPA to base its actions concerning SIPs on such grounds. *Union Electric Co. v. U.S. E.P.A.* 427 U.S. 246, 256-66 (S.Ct. 1976); 42 U.S.C. 7410(a)(2).

### Executive Order 12866

The Office of Management and Budget has exempted this rule from the requirement of section 6 of Executive Order 12866.

This action has been classified as a Table 2 action by the Regional Administrator under the procedures published in the Federal Register on January 19, 1989 (54 FR 2214-2225), as revised by an October 4, 1993, memorandum from Michael H. Shapiro,

Acting Assistant Administrator for Air and Radiation. A future document will inform the general public of these tables. On January 6, 1989, the Office of Management and Budget (OMB) waived Table 2 and Table 3 SIP revisions (54 FR 222) from the requirements of section 3 of Executive Order 12291 for 2 years. The EPA has submitted a request for a permanent waiver for Table 2 and Table 3 SIP revisions. The OMB has agreed to continue the waiver until such time as it rules on EPA's request. This request continues in effect under Executive Order 12866 which superseded Executive Order 12291 on September 30, 1993.

### List of Subjects in 40 CFR Part 52

Environmental protection, Air pollution control, Reporting and recordkeeping requirements, and Sulfur dioxide.

Authority: 42 U.S.C. 7401-7671q.

Dated: March 31, 1994.

Jack W. McGraw,

Acting Regional Administrator.

[FR Doc. 94-9292 Filed 4-15-94; 8:45 am]

BILLING CODE 6560-50-P

### 40 CFR Part 52

[FRL-4875-2]

### Redesignation of the Yavapai-Apache Reservation to a PSD Class I Area; State of Arizona

AGENCY: Environmental Protection Agency (EPA).

ACTION: Notice of proposed rulemaking (NPR).

**SUMMARY:** The purpose of this action is to propose approval and seek public comment on the request by the Yavapai-Apache Tribal Council to redesignate the Yavapai-Apache Reservation ("the Reservation") in the State of Arizona to Class I under EPA's regulations for prevention of significant deterioration of air quality. The Class I designation will result in lowering the allowable increases in ambient concentrations of particulate matter, sulfur dioxide, and nitrogen dioxide on the Reservation. **DATES:** Comments and requests for a public hearing must be received on or before May 18, 1994.

**ADDRESSES:** Written comments should be addressed to: Kelly Fortin, Air and Toxics Division (A-5-1), U.S. Environmental Protection Agency, 75 Hawthorne Street, San Francisco, CA 94105-3901. Requests for a public hearing shall be in writing to the above address and shall state the nature of the issues proposed to be raised in the

hearing. Any hearing will be strictly limited to the subject matter of the proposal.

Supporting information used in developing the proposed rule and materials submitted to EPA relevant to the proposed action are available for public inspection and copying at the docket address listed above during normal business hours. A reasonable fee may be charged for copying.

**FOR FURTHER INFORMATION CONTACT:** Kelly Fortin, Air and Toxics Division (A-5-1), USEPA, Region 9, 75 Hawthorne Street, San Francisco, CA 94105-3901, (415) 744-1259.

**SUPPLEMENTARY INFORMATION:** Part C of the Clean Air Act ("the Act") provides for the prevention of significant deterioration (PSD) of air quality. The intent of this part is to prevent deterioration of existing air quality, particularly in areas considered to be pristine. The Act provides for three basic classifications applicable to all lands of the United States. Associated with each classification are increments which represent the maximum allowable increase in ambient air pollutant concentrations above a baseline concentration. A Class I designation applies to areas of special national or regional value from a natural, scenic, recreational, or historic perspective. The PSD regulations provide special protection for such areas. Class II applies to areas in which pollutant increases accompanying moderate growth would be allowed. Class III applies to those areas in which considerably more air quality deterioration would be considered acceptable.

Under the 1977 amendments to the Act, all areas of the country that met the National ambient air quality standards were initially designated Class II, except for certain international parks, wilderness areas, national memorial parks, national parks, and any other areas previously designated Class I. Section 164 of the Act allows States and Indian governing bodies to reclassify areas under their jurisdiction to accommodate the social, economic, and environmental needs and desires of the local population. Reservations that have previously been reclassified as Class I areas include the Northern Cheyenne, Fort Peck, and Flathead Reservations in Montana and the Spokane Reservation in Washington.

A Class I redesignation will result in lowering the allowable increases in

ambient concentrations of particulate matter, sulfur dioxide, and nitrogen dioxide on the Reservation. Only facilities defined by the PSD regulations, 40 CFR 52.21, as major stationary sources or major modifications are required to perform an air quality impact analysis for Class I and Class II areas. These facilities are typically large industrial sources such as refineries and electric utilities.

It is important to note that no new permits and no new substantive requirements are applicable as a result of a redesignation to Class I. The same analyses and control technology requirements apply as if the area was designated as Class II. The difference between the two designations, in this case, is that the maximum increase in ambient concentration of a given pollutant<sup>2</sup> allowed over a baseline concentration is lower in a Class I area. This affords a Class I area greater protection from the cumulative impacts of many facilities locating in and around the Class I area.

Typically a facility must be upwind of and quite close to a Class I area for it to have a significant impact (greater than 1 microgram per cubic meter). Facilities that are not found to have a significant impact may usually construct without performing a "full" (detailed) air quality analysis. Those facilities that may have a significant impact on a Class I area must perform a more detailed air quality analysis and may be required to propose and apply mitigation measures to reduce emissions to a level that will have an insignificant impact on the Class I area.

#### **Yavapai-Apache Request for Redesignation**

On December 17, 1993, the Yavapai-Apache Tribal Council (herein referred to as "the Tribal Council") submitted to EPA a proposal to redesignate the Yavapai-Apache Reservation from Class II to Class I. With their request, the Tribal Council submitted an Air Quality Redesignation Plan, documentation of public notification, a record of the public hearing held on October 21, 1993, and comments received by the Tribal Council on the proposed redesignation.

The Yavapai-Apache Reservation is located in the Verde Valley of Central Arizona about 90 miles north of Phoenix and 55 miles south of Flagstaff. The Reservation was established by Executive Order in 1871 and is composed of five land parcels, totalling

635 acres, held by the Federal Government as trust lands.

The main parcel, the Middle Verde Reservation, is approximately 458 acres and is located two miles west of Interstate 17. A second parcel, the Camp Verde Reservation, is located approximately five miles southeast of the main parcel, adjacent to the town of Camp Verde, and is forty acres. The Clark Reservation, a parcel of 58.5 acres, is located in Clarkdale, 25 miles northwest of the Middle Verde Reservation. A fourth parcel, the Rimrock Reservation, is located in Rimrock about 10 miles east of the main parcel and consists of 3.75 acres. The fifth parcel, approximately 75 acres, is located on Interstate 17 near the entrance to the Montezuma Castle National Monument and is intended for commercial development.

#### **Statutory and Regulatory Requirements for Redesignation**

Section 164 of the Clean Air Act and Federal regulations set forth at 40 CFR 52.21(g) outline the requirements for redesignation of areas under the PSD program. The Act provides that lands within the exterior boundaries of reservations of federally recognized Indian tribes may be redesignated only by the appropriate Indian Governing Body. Under section 164(b)(2) and 40 CFR 52.21(g)(5), EPA may disapprove a redesignation only if it finds, after notice and opportunity for hearing, that the redesignation does not meet the procedural requirements of section 164 or is a mandatory Class I area that may not be redesignated. The latter does not apply to the area proposed for redesignation. In addition, the Indian Governing Body may resubmit the proposal after correcting any deficiencies noted by the Administrator.

The procedural requirements for a Class I redesignation by an Indian Governing Body are as follows: (1) At least one public hearing must be conducted in accordance with the requirements set forth at 40 CFR 51.102; (2) other States, Indian Governing Bodies, and Federal Land Managers whose lands may be affected by the proposed redesignation must be notified at least 30 days prior to the public hearing; (3) at least 30 days prior to the public hearing, a satisfactory description and analysis of the health, environmental, economic, social and energy effects of the proposed redesignation must be prepared and made available for public inspection and be referenced in the public hearing notice; (4) if any Federal lands are included in the redesignation, the redesignating authorities must provide

<sup>1</sup> The 1990 CAA Amendments included provisions to allow the boundaries of existing Federal Class I areas to be expanded, but no new Class I areas were created.

<sup>2</sup> There are currently PSD increments established for nitrogen dioxide, sulfur dioxide, and particulate matter. 40 CFR 52.21(c).

written notice to the appropriate Federal Land Managers and an opportunity to confer and submit written comments and recommendations; (5) the Indian Governing Body must consult with the State(s) in which the Reservation is located and that border the Reservation.

#### Tribal Council Submittal

The December 17, 1993 request for redesignation includes evidence that all of the statutory and regulatory requirements for redesignation of the Yavapai-Apache Reservation from Class II to Class I have been met by the Yavapai-Apache Tribal Council. The Yavapai-Apache Tribal Council is the Indian Governing Body for the Yavapai-Apache Reservation, and only lands within the exterior boundaries of the Reservation are proposed for redesignation.

Pursuant to 40 CFR 51.102, the Tribal Council conducted a public hearing on October 21, 1993 at the Clarkdale Community Building in Clarkdale, Arizona. Notice of the hearing was provided to the required parties and numerous other public agencies and interested parties, was posted in public locations, and was provided to national and local media. A description and analysis of the health, environmental, economic, social, and energy effects of the proposed redesignation entitled, "Yavapai-Apache Tribe Air Quality Redesignation Plan," was completed in September 1993, and its availability was announced in the public hearing notices. Evidence that the Tribe consulted with State officials prior to proposing the redesignation is also included in the submittal. Therefore, the documentation submitted by the Tribal Council shows that all statutory and regulatory procedural requirements for redesignation have been met.

#### Summary of Action

Since EPA's review has not revealed any procedural deficiencies, the redesignation is hereby proposed for approval. The public is invited to comment on whether the Tribal Council has met all the procedural requirements of section 164 of the Act. Comments should be submitted to the address listed in the front of this document. Public comments received by May 18, 1994 will be considered in the final rulemaking action taken by EPA.

#### Administrative Review

The Office of Management and Budget has exempted this rule from the requirements of section 6 of Executive Order 12866.

Under the Regulatory Flexibility Act, 5 U.S.C. 600 *et seq.*, EPA must prepare

a regulatory flexibility analysis assessing the impact of any proposed or final rule on small entities. 5 U.S.C. 603 and 604. Alternatively, EPA may certify that the rule will not have a significant impact on a substantial number of small entities. Small entities include small businesses, small not-for-profit enterprises and government entities with jurisdiction over populations of less than 50,000. The proposed action affects only major stationary sources, as defined by 40 CFR 52.21, will not result in any additional requirements for small entities. Therefore, I certify that this action does not have a significant impact on a substantial number of small entities.

#### List of Subjects in 40 CFR Part 52

Air pollution control, Carbon monoxide, Hydrocarbons, Intergovernmental relations, Nitrogen dioxide, Ozone, Particulate matter, Reporting and recordkeeping requirements, Sulfur oxides.

Authority: 42 U.S.C. 7401-7642.

Dated: April 4, 1994.

John Wise,

Acting Regional Administrator.

[FR Doc. 94-9293 Filed 4-15-94; 8:45 am]

BILLING CODE 6560-50-F

#### 40 CFR Parts 261, 271, and 302

[FRL-4863-5]

RIN 2050-AD59

#### Extension of Comment Period for Proposed Rule; Hazardous Waste Management System; Carbamate Production Identification and Listing of Hazardous Waste; and CERCLA Hazardous Substance Designation and Reportable Quantities

AGENCY: Environmental Protection Agency.

ACTION: Notice of proposed rulemaking; extension of comment period.

SUMMARY: The U.S. Environmental Protection Agency (EPA) is extending the comment period for a proposed rule published on March 1, 1994 [59 FR 9808] which proposed to amend the regulations for hazardous waste management under the Resource Conservation and Recovery Act (RCRA) by proposing to list as hazardous certain wastes from the production of carbamate chemicals. The original deadline for comments is being extended, and comments must now be submitted by May 16, 1994. The Agency recognizes that the docket for this proposed listing contains many technical documents. In addition,

several members of the public have specifically requested additional time to submit comments to properly address areas of concern. In light of these circumstances, the Agency is extending the comment period on the proposed rule by two weeks. Because the Agency has committed to make its final listing determination for the wastes proposed in the notice of March 1, 1994 on or before January 31, 1995, this two week extension is the maximum that the Agency can reasonably grant.

DATES: Comments for this proposed rule should be submitted in writing to the address shown below on or before May 16, 1994 to be considered in the formulation of the final rule.

ADDRESSES: The official record of this rule-making is identified by Docket Number F-94-CPLP-FFFFF and is located at the following address: EPA RCRA Docket Clerk, room 2616 (5305), U.S. Environmental Protection Agency, 401 M Street SW., Washington, DC 20460.

The docket is open from 9 a.m. to 4 p.m., Monday through Friday, excluding Federal holidays. The public must make an appointment to review docket materials by calling (202) 260-9327. The public may copy 100 pages from the docket at no charge; additional copies are \$0.15 per page.

FOR FURTHER INFORMATION CONTACT: The RCRA/Superfund Hotline, at (800) 424-9346 (toll-free) or (703) 412-9810, in the Washington, DC metropolitan area. The TDD Hotline number is (800) 553-7672 (toll-free) or (703) 486-3323, locally. For technical information on the proposed listing, contact Mr. John J. Austin at (202) 260-4789, Office of Solid Waste (5304), U.S. Environmental Protection Agency, 401 M Street SW., Washington, DC 20460.

For technical information on the CERCLA aspects of this rule, contact: Ms. Gerain H. Perry, Response Standards and Criteria Branch, Emergency Response Division (5202G), U.S. Environmental Protection Agency, 401 M Street, SW., Washington, DC 20460, (703) 603-8760.

Dated: April 7, 1994.

Walter W. Kovalick, Jr.,

Acting Assistant Administrator.

[FR Doc. 94-9286 Filed 4-15-94; 8:45 am]

BILLING CODE 6560-50-P

**FEDERAL COMMUNICATIONS COMMISSIONS**
**47 CFR PART 64**
**[CC Docket No. 91-281; FCC 94-59]**
**Calling Number Identification Service—Caller ID**
**AGENCY:** Federal Communications Commission.

**ACTION:** Proposed rules.

**SUMMARY:** In a Report and Order and Further Notice of Proposed Rulemaking adopted March 8, 1994, the Commission required that carriers participating in the offering of calling party number based services must inform telephone customers regarding the availability of identification services and how to invoke the privacy protection mechanism. For ANI or charge number services for which such privacy is not provided, the rules require that the notification inform telephone customers of the restrictions on the reuse or sale of subscriber information.

In the Further Notice of Proposed Rulemaking adopted March 8, 1994, the Commission seeks comments on whether the Commission should prescribe more detailed instructions regarding subscriber education requirements, and on whether the policies for calling party number delivery adopted in the Report and Order should extend to other services.

**DATES:** Comments are due May 18, 1994, and reply comments due June 21, 1994.

**ADDRESSES:** Federal Communications Commission, 1919 M Street, NW., Washington, DC 20554.

**FOR FURTHER INFORMATION CONTACT:** Suzanne Hutchings, Domestic Services Branch, Domestic Facilities Division, Common Carrier Bureau, (202) 634-1802, or Olga Madruga-Forti, Domestic Services Branch, Domestic Facilities Division, Common Carrier Bureau, (202) 634-1816.

**SUPPLEMENTARY INFORMATION:** This summarizes the Commission's Further Notice of Proposed Rulemaking in the matter of Rules and Policies Regarding Calling Number Identification Service. The item was adopted by the Commission on March 8, 1994, and released March 29, 1994, and bears the title of "Rules and Policies Regarding Calling Number Identification Services—Caller ID", Report and Order (R&O) and Further Notice of Proposed Rulemaking (Further NPRM) (CC Docket 91-281, FCC 94-59). The R&O is summarized elsewhere in this issue.

The Further NPRM and supporting file are available for inspection and

copying during the weekday hours of 9 a.m. to 4:30 p.m. in the FCC Reference Center, room 239, 1919 M St., NW., Washington, DC, or copies may be purchased from the Commission's duplicating contractor, ITS, 2100 M St., NW., Suite 140, Washington, DC 20037, phone (202) 857-3800. The Further NPRM will be published in the FCC Record.

**Analysis of Proceeding**

This summarizes the Commission's Further NPRM in the matter of Rules and Policies Regarding Calling Number Identification Services—Caller ID, Report and Order and Further Notice of Proposed Rulemaking (CC Docket 91-281, FCC 94-59, adopted March 8, 1994, and released March 29, 1994). In the Notice of Proposed Rulemaking, adopted October 23, 1991, (56 FR 53700, November 8, 1991), the Commission proposed to establish federal policies and rules concerning interstate calling number identification service (caller ID). On March 8, 1994, the Commission adopted a Report and Order which found that a federal model for interstate delivery of calling party number is in the public interest, that calling party privacy must be protected, and that certain state regulation of interstate calling party number (CPN) based services, including interstate caller ID, must be preempted.

Specially, the Commission's rules require that common carriers using Common Channel Signalling System 7 (SS7) and subscribing to or offering any service based on SS7 functionality must transmit the calling party number parameter and its associated privacy indicator on an interstate call to connecting carriers. The rules also require that carriers offering CPN delivery services provide, at no charge to the caller, an automatic per call blocking mechanism for interstate callers. The rules require that terminating carriers providing calling party based services, including caller ID, honor the privacy indicator. The Commission found that the costs of interstate transmission of CPN are *de minimis*, and that the CPN should be transmitted among carriers without additional charge. The rules adopted in the R&O require that carriers participating in the offering of any service that delivers CPN on interstate calls inform telephone subscribers that the subscriber's number may be revealed to called parties and describe what steps subscribers can take to avoid revealing their numbers. Further, the Commission adopts rules restricting the reuse or sale of information generated by automatic number identification

(ANI) or charge number services, absent affirmative subscriber consent.

In the Further Notice of Proposed Rulemaking (Further NPRM) adopted March 8, 1994, the Commission seeks comment on whether it should prescribe detailed instructions regarding what form education should take or prescribe more precisely responsibilities of various carriers. The Commission stated a particular interest in specific joint industry education proposals.

In the Further NPRM, the Commission tentatively concludes that its policies for calling party number delivery should apply equally to services delivering calling party name, and seeks comment on this tentative conclusion. It also seeks comment on whether the policies adopted in the Report and Order should be extended to other services that might identify the calling party.

**Further Notice of Proposed Rulemaking**

This is a nonrestricted notice and comment rulemaking proceeding. *Ex Parte* presentations are permitted, except during the Sunshine Agenda period, provided they are disclosed as provided in Commission rules. See generally 37 CFR 1.1202, 1.1203 and 1.1206(a).

We certify that the Regulatory Flexibility Act of 1980 does not apply to this rulemaking proceeding because if the proposed rule amendment is promulgated, there will not be a significant economic impact on a substantial number of small business entities, as defined in section 601(3) of the Regulatory Flexibility Act. The Secretary shall send a copy of this Report and Order and Further Notice of Proposed Rulemaking, including the Initial Regulatory Flexibility Analysis, to the Chief Counsel for Advocacy of the Small Business Administration in accordance with paragraph 603(A) Regulatory Flexibility Act. Public Law 96-354, 94 Stat. 1164, 5 U.S.C. section 601 *et seq.* (1981).

Pursuant to applicable procedures set forth in §§ 1.415 and 1.419 of the Commission's rules, 47 CFR 1.415 and 1.419, interested parties may file comments on or before May 18, 1994, and reply comments on or before June 21, 1994. To file formally in this proceeding, interested parties must file an original and four copies of all comments, reply comments, and supporting documents with the reference number "CC Docket 91-281" on each document. If interested parties want each Commissioner to receive a personal copy of comments, interested parties must file an original plus nine copies. Interested parties should send comments and reply comments to the

Office of the Secretary, Federal Communications Commission, Washington, DC 20554. Comments and reply comments will be available for public inspection during regular business hours in the FCC Reference Center, room 239, Federal Communications Commission, 1919 M Street, NW., Washington, DC. Copies of comments and reply comments are available through the Commission's duplicating contractor: International Transcription Service, Inc. (ITS, Inc), 2100 M Street, NW., suite 140, Washington, DC 20037, (202) 857-3800.

Federal Communications Commission.

William F. Caton,

Acting Secretary.

[FR Doc. 94-9359 Filed 4-15-94; 8:45 am]

BILLING CODE 6712-01-M

## DEPARTMENT OF THE INTERIOR

### Fish and Wildlife Service

#### 50 CFR Part 17

#### RIN 1018-AC44

### Endangered and Threatened Wildlife and Plants; Proposed Rule To List the Saint Francis' Satyr as Endangered

AGENCY: Fish and Wildlife Service, Interior.

ACTION: Proposed rule.

**SUMMARY:** The Fish and Wildlife Service (Service) proposes to list a butterfly, the Saint Francis' satyr (*Neonympha mitchellii francisci*) as an endangered species pursuant to the Endangered Species Act of 1973 (Act), as amended. This butterfly is known from a single locality in North Carolina. Recent heavy collecting pressure has resulted in a reduction of the only known population of this subspecies and is believed to pose an imminent threat to the species' survival. Due to the need to reduce or eliminate the likelihood of further collection, an emergency rule is published elsewhere in today's Federal Register to provide this butterfly with immediate protection under the Act for a period of 240 days. Proposed listing, if made final, would implement long-term Federal protection and allow for recovery measures in accordance with the Act's provisions.

**DATES:** Comments from all interested parties must be received by June 17, 1994. Public hearing requests must be received by June 2, 1994.

**ADDRESSES:** Comments and material concerning this proposal should be sent to the Field Supervisor, Asheville Field Office, U.S. Fish and Wildlife Service,

330 Ridgefield Court, Asheville, North Carolina 28806. Comments and material received will be available for public inspection, by appointment, during normal business hours at the above address.

**FOR FURTHER INFORMATION CONTACT:** Ms. Nora Murdock at the above address (704/665-1195, Ext. 231).

#### SUPPLEMENTARY INFORMATION:

##### Background

Saint Francis' satyr (*Neonympha mitchellii francisci*), one of the rarest butterflies in eastern North America, was described by Parshall and Kral (1989) from materials collected in North Carolina.

The authors estimate that the single known population probably produces less than 100 adults annually. Shortly after its discovery in 1989, Saint Francis' Satyr was reported to have been collected to extinction (Refsnider 1991, Schweitzer 1989). In 1992, the subspecies was rediscovered at its type locality during the course of a Service-funded status survey. The Act defines "species" to include any subspecies of fish or wildlife or plants, and any distinct population segment of any species of vertebrate fish and wildlife. Although *N. m. francisci* is recognized taxonomically as a subspecies, it will be referred to as a "species" throughout the remainder of this rule.

Saint Francis' satyr is a fairly small, dark brown butterfly of the subfamily Satyrinae and the family Nymphalidae, which include many species of butterflies commonly called satyrs and wood nymphs. *Neonympha m. francisci* and *N. m. mitchellii*, the northern subspecies which is listed as endangered (May 20, 1992: 57 FR 21569), are nearly identical in size and show only a slight degree of sexual size dimorphism (Hall 1993, Parshall and Kral 1989). Saint Francis' satyr has conspicuous "eyespot" (like most members in the wood nymph group) on the lower surfaces of the wings, and these eyespots are a dark maroon brown in the center—reflecting a silver cast in certain light. The border of the eyespots is straw yellow with an outermost border of dark brown. These eyespots, usually round to slightly oval, are well developed on the fore and hind wings. The spots are accentuated by two bright orange bands along the edges of the posterior wing and by two darker brown bands across the central portion of each wing. Saint Francis' satyr, as well as the nominate subspecies *mitchellii*, can be distinguished from its congener, *N. areolata*, by the latter's well-marked eyespots on the upper wings and

brighter orange bands on the hind wings (Refsnider 1991, McAlpine *et al.* 1960, Wilsman and Schweitzer 1991, Hall 1993).

Saint Francis' satyr is extremely restricted geographically and it is presently known to exist only from a single population in North Carolina. The annual life cycle of *francisci* unlike that of its northern relative *mitchellii*, is bivoltine. It has two adult flights or generations annually. Little is known about its life history, and larval host plants are thought to be graminoids such as grasses, sedges, and rushes. The habitat occupied by *francisci* consists primarily of wide, wet meadows dominated by sedges and other wetland graminoids. In the North Carolina sandhills, these wet meadows are often relicts of beaver activity. These boggy areas are quite acidic and ephemeral, succeeding to either pocosin or swamp forest if not kept open by frequent fires or beaver activity.

The sandhills were once covered with an open type of woodland, dominated by longleaf pine, wire grass, and other fire-tolerant species. The type of forest that presently exists along the creek inhabited by *francisci* can only mature under a long period of fire suppression. Parshall and Kral (1988) speculate that *francisci* is a relict from a more widespread southern distribution, and its current limited distribution could also be a result of the enormous environment changes that have taken place in the past 100 years within the southern coastal plain. Extensive searches of other suitable habitat in North Carolina and South Carolina have turned up no additional populations of this butterfly (Hall 1993, Schweitzer 1989).

Federal actions on this species began on November 21, 1991 when it was included as a Category 2 species in the Animal Notice of Review (56 FR 58804). Category 2 species are those species for which the Service believes that Federal listing as endangered or threatened is possibly appropriate, but for which conclusive data on biological vulnerability and threat are currently not available to support a proposed rule. Based on recent surveys conducted by Service and State personnel, the Service now concludes that sufficient information exists to propose listing *Neonympha mitchellii francisci* as endangered.

#### Summary of Factors Affecting the Species

Section 4(a)(1) of the Act (16 U.S.C. 1531 *et seq.*) and regulations (50 CFR part 424) promulgated to implement the listing provisions of the Act set forth the

procedures for adding species to the Federal list. A species may be determined to be an endangered or threatened species due to one or more of the five factors described in section 4(a)(1). These factors and their application to Saint Francis' satyr (*Neonympha mitchellii francisci*) are as follows:

**A. The Present or Threatened Destruction, Modification, or Curtailment of Its Habitat or Range**

Due to its recent discovery, it is impossible to determine what the original range of this butterfly was. Based upon its demonstrated dependency on periodic fires to create new habitat and the present trend of fire suppression on private lands, it is assumed that *francisci* once occupied a more extensive area with a greater number of populations and individuals. Massive habitat alterations are a major factor in the reduction of the range of *francisci*. The extensive loss of wetland habitats in the Carolina Coastal plains and the draining of swamps, pocosins, bays, savannas, flatwoods, and bogs for conversion to agriculture and silviculture is well documented.

The extirpation of beavers from the Carolinas at the turn of the century may have played an important role in the reduction of this butterfly's range. Beavers play an active role in the creation of sedge meadow habitats which are favored by Saint Francis' satyr (Hall 1993, Woodward and Hazel 1991). The open woodlands and wetlands of the coastal plain have declined drastically during the past two centuries; thus the range of *francisci* has become increasingly fragmented and the structure of their meta-populations may have been destroyed. The fracturing of meta-populations is cited in the decline of the aragos skipper and a number of other butterflies associated with tall grass prairies (Panzer 1988, D. Schweitzer pers. comm.)

Since *francisci* may be a relict population already, the further destruction and fragmentation of its existing habitat has brought it close to extinction. The sole remaining population is now fragmented into less than 5 or 6 small colonies of individuals which occupy a total area of a few square miles.

**B. Overutilization for Commercial, Recreational, Scientific, or Educational Purposes**

Both subspecies of *Neonympha mitchellii* are highly prized by collectors, including commercial collectors, who often collect every available individual. Several

populations of the nominate subspecies, *mitchellii*, have been destroyed by collectors and other populations are extremely vulnerable to this threat (Refsnider 1991). The single known population of *francisci* was extremely over-collected following its initial discovery and it is believed to have been extirpated from the wild. Since the emergency listing of the nominate subspecies, *mitchellii*, in 1991, North Carolina was the only place where *Neonympha mitchellii* could be legally collected in the wild. Following the emergency listing of the northern subspecies (Mitchell's satyr), the North Carolina Heritage Program received several inquiries from collectors concerning the location of the North Carolina population (Saint Francis' satyr). These collectors expressed apprehension about placing any restrictions on the collecting of this rare and much sought after satyr—*francisci*. Collectors have reportedly visited the known site of *francisci* on a daily basis during the flight period, taking every available adult (Hall 1993). After this initial wave of over-collecting, many unsuccessful searches were made for Saint Francis' satyr before it was eventually rediscovered. Little is known about this butterfly's ecological requirements and life history, but it appears to be more vulnerable than its northern relative. It may be more dependent upon a longer meta-population structure than its northern cousin in order to colonize new sites or to recolonize old sites from which it has been extirpated.

**C. Disease or Predation**

There is no available evidence at this time that predation or disease are factors in this butterfly's decline or threaten its continued existence in the wild.

**D. The Inadequacy of Existing Regulatory Mechanisms**

Presently, insects are not protected from taking under North Carolina law. Also the Department of Defense regulations do not prohibit the take of butterflies on military lands (Saint Francis' satyr occurs on Fort Bragg). Federal listing of this butterfly will provide legal protection against taking and illegal trade in the species.

**E. Other Natural or Manmade Factors Affecting Its Continued Existence**

This species is dependent upon some form of disturbance (e.g., periodic fires and/or beaver impoundments) to create the desired habitat needed for survival. But intense fires at critical stages during its life cycle could eliminate small colonies of this butterfly. Since only one

population of *francisci* remains and there are no other known adjacent populations to recolonize extirpated sites, this species is extremely vulnerable to catastrophic climatic events, inbreeding depression, disease and parasitism. Part of its habitat is adjacent to a well-traveled road where there is the possible threat of toxic chemical spills into its wetland habitat. Current military use of the lands favor this species, due to the frequent fires associated with shelling. The Department of Defense personnel are aware of the species' plight and have limited troop movement through the area. Heavy siltation of the small drainage areas occupied by *francisci* could pose a potential threat to the species. Other potential threats to this butterfly include pest control programs for mosquitoes and/or gypsy moths and beaver eradication.

In developing this proposal the Service has carefully assessed the best scientific and commercial information available regarding the past, present, and future threats faced by this species. Based on this evaluation, the preferred action is to list Saint Francis' satyr as endangered. With only one population remaining (already diminished by intensive collecting) and with the other subspecies (*mitchellii*) having been eliminated from half of the States where it historically occurred, the threat of over-collecting is well documented.

The potential for further reduction of this last known remaining population of *francisci* could severely reduce the likelihood of this butterfly's survival. Therefore, the Service is listing the species as endangered on an emergency basis to provide maximum protection to the remaining population during the 1994 flight period. At the same time, the Service is initiating the normal listing process by proposing the species for endangered status.

**Critical Habitat**

Section 4(a)(3) of the Act, as amended, requires that, to the maximum extent prudent and determinable, the Secretary designate critical habitat at the time a species is determined to be endangered or threatened. At this time, the Service has made a preliminary finding that designation of critical habitat is not prudent for this species. As discussed under Factor B in the "Summary of Factors Affecting the Species" section, Saint Francis' satyr has already been impacted by over-collecting and continues to be threatened by collecting pressure. Publication of critical habitat descriptions and maps would make this satyr even more vulnerable to

collection, and would increase enforcement problems and the likelihood of extinction. Protection of this species' habitat will be addressed through the recovery process and through the section 7 jeopardy standard. The single remaining population is located on military lands, where the Department of Defense is aware of its occurrence. Comments regarding the designation of critical habitat will be accepted and reviewed during the comment period established by this proposed rule.

#### Available Conservation Measures

Conservation measures provided to species listed as endangered or threatened under the Endangered Species Act include recognition, recovery actions, requirements for Federal protection, and prohibitions against certain practices. Recognition through listing encourages and results in conservation actions by Federal, State, and private agencies, groups, and individuals. The Endangered Species Act provides for possible land acquisition and cooperation with the States and requires that recovery actions be carried out for all listed species. The protection required of Federal agencies and the prohibitions against certain activities involving listed animals are discussed, in part, below.

Section 7(a) of the Act, as amended, requires Federal agencies to evaluate their actions with respect to any species that is proposed or listed as endangered or threatened and with respect to its critical habitat, if any is being designated. Regulations implementing this interagency cooperation provision of the Act are codified at 50 CFR part 402. Section 7(a)(4) requires Federal agencies to confer informally with the Service on any action that is likely to jeopardize the continued existence of a proposed species or result in the destruction or adverse modification of proposed critical habitat. If the species is listed subsequently, section 7(a)(2) requires Federal agencies to ensure that activities they authorize, fund, or carry out are not likely to jeopardize the continued existence of such a species or to destroy or adversely modify its critical habitat. If a Federal action may affect a listed species or its critical habitat, the responsible Federal agency must enter into formal consultation with the Service. Federal activities that could impact Saint Francis' satyr and its habitat in the future include, but are not limited to, the following: Road and firebreak construction, pesticide application, beaver control, troop movements, prescribed burning, the fire suppression, and facilities construction.

The only known population of Saint Francis' satyr is located on military lands, where the Department of Defense is already working with the Service to secure the protection and proper management of this butterfly, while accommodating military activities to the extent possible. Conservation of this butterfly is consistent with most ongoing military operations at the occupied site, and the listing of the species is not expected to result in significant restrictions on military use of the land.

The Act and implementing regulations found at 50 CFR 17.21 set forth a series of general prohibitions and exceptions that apply to all endangered wildlife. These prohibitions, in part, make it illegal for any person subject to the jurisdiction of the United States to take (includes harass, harm, pursue, hunt, shoot, wound, kill, trap, or collect; or to attempt any of these), import or export, ship in interstate commerce in the course of a commercial activity, or sell or offer for sale in interstate or foreign commerce any listed species. It also is illegal to possess, sell, deliver, carry, transport, or ship any such wildlife that has been taken illegally. Certain exceptions apply to agents of the Service and State conservation agencies.

Permits may be issued to carry out otherwise prohibitions activities involving endangered wildlife species under certain circumstances. Regulations governing permits are found at 50 CFR 17.22 and 17.23. Such permits are available for scientific purposes, to enhance the propagation or survival of the species, and/or for incidental take in connection with otherwise lawful activities.

#### Public Comments Solicited

The Service intends that any final action resulting from this proposal will be as accurate and as effective as possible. Therefore, comments or suggestions from the public, other concerned governmental agencies, the scientific community, industry, or any other interested party concerning this proposed rule are hereby solicited. Comments particularly are sought concerning:

- (1) Biological, commercial trade or other relevant data concerning any threat (or lack thereof) of this species;
- (2) The location of any additional populations of this species and the reasons why any habitat should or should not be determined to be critical habitat as provided by section 4 of the Act;
- (3) Additional information concerning the range, distribution, and population size of this species; and

(4) Current or planned activities in the subject area and their possible impacts on this species.

Final promulgation of the regulation on this species will take into consideration the comments and any additional information received by the Service, and such communications may lead to a final regulation that differs from this proposal.

The Endangered Species Act provides for a public hearing on this proposal, if requested. Requests must be received within 45 days of the date of publication of the proposal. Such requests must be made in writing and addressed to the Field Supervisor, Asheville Field Office (see ADDRESSES section).

#### National Environmental Policy Act

This Fish and Wildlife Service has determined that an Environmental Assessment, as defined under the authority of the National Environmental Policy Act of 1969, need not be prepared in connection with regulations adopted pursuant to Section 4(a) of the Endangered Species Act of 1973, as amended. A notice outlining the Service's reasons for this determination was published in the Federal Register on October 25, 1983 (49 FR 49244).

#### References Cited

Refer to the accompanying emergency rule for this section.

#### Author

The primary author of this proposed rule is Ms. Nora Murdock (see ADDRESSES section) (704/665-1195, Ext. 231).

#### List of Subjects in 50 CFR Part 17

Endangered and threatened species, Exports, Imports, Reporting and recordkeeping requirements, and Transportation.

#### Regulation Promulgation

#### PART 17—[AMENDED]

Accordingly, it is hereby proposed to amend part 17, subchapter B of chapter 1, title 50 of the Code of Federal Regulations, as set forth below:

(1) The authority citation for part 17 continues to read as follows:

**Authority:** 16 U.S.C. 1361-1407; 16 U.S.C. 1531-1544; 16 U.S.C. 4201-4245; Pub. L. 99-625, 100 Stat. 3500; unless otherwise noted.

(2) Amend § 17.11(h) by adding the following, in alphabetical order under "Insects" to the List of Endangered and Threatened Wildlife, to read as follows:

#### § 17.11 Endangered and threatened wildlife.

\* \* \* \* \*



(h) \* \* \*

Species		Historic range	Vertebrate population where endangered or threatened	Status	When listed	Critical habitat	Special rules
Common name	Scientific name						
Insects:							
Butterfly, Saint Francis' satyr.	<i>Neonympha mitchellii francisci</i> .	U.S.A. (NC) .....	NA .....	E	.....	NA .....	.....

Dated: April 8, 1994.

Mollie H. Beattie,

Director, Fish and Wildlife Service.

[FR Doc. 94-9219 Filed 4-15-94; 8:45 am]

BILLING CODE 4310-55-M

**50 CFR Part 17****Endangered and Threatened Wildlife and Plants; 12-Month Petition Finding for the California Tiger Salamander**

AGENCY: Fish and Wildlife Service, Interior.

ACTION: Notice of petition finding.

**SUMMARY:** The Fish and Wildlife Service (Service) announces a 12-month finding on a petition to list the California tiger salamander (*Ambystoma californiense*) pursuant to the Endangered Species Act of 1973, as amended (Act). The petition has been found to be warranted but precluded by pending listing actions on higher priority species. The Service continues to seek data and comments from the public on the status and threats to this animal.

**DATES:** The finding reported in this document was made on April 12, 1994. Comments and information may be submitted until further notice.

**ADDRESSES:** Comments and materials concerning this petition may be sent to the Field Supervisor, Sacramento Field Office, U.S. Fish and Wildlife Service, 2800 Cottage Way, Room E-1803, Sacramento, California 95825-1846. The petition, finding, supporting data, comments, and materials received will be available for public inspection, by appointment, during normal business hours at the above address.

**FOR FURTHER INFORMATION CONTACT:** Peter Sorensen, Sacramento Field Office (see ADDRESSES section) at 916/978-4866.

**SUPPLEMENTARY INFORMATION:****Background**

Section 4(b)(3)(B) of the Endangered Species Act of 1973, as amended (16

U.S.C. 1531 *et seq.*), requires that for any petition to revise the Lists of Endangered and Threatened Wildlife and Plants that presents substantial scientific and commercial information a finding be made within 12 months of the date of receipt of the petition on whether the petitioned action is (a) not warranted, (b) warranted, or (c) warranted but precluded from immediate proposal by other pending proposals to list, delist, or reclassify species. Such 12-month findings are to be published promptly in the *Federal Register*. If the finding is warranted but precluded, the Service shall, within 12 months of such finding, again make one of the three findings described above with regard to the petition.

The California tiger salamander was designated as a category 2 candidate for listing in the November 21, 1991, Animal Notice of Review (56 FR 58804). A category 2 candidate is a species for which data in the Service's possession indicate listing is possibly appropriate, but for which substantial information on biological vulnerability and threats is not currently available to support proposals for listing. In a petition dated February 20, 1992, and received on February 26, 1992, Dr. H. Bradley Shaffer of the University of California, Davis, requested the Service list the California tiger salamander as an endangered species. The petition cited numerous threats to the species, including habitat loss and fragmentation, predation by introduced species, and other anthropogenic factors. The Service announced its 90-day petition finding in the *Federal Register* on November 19, 1992 (57 FR 54545), which concluded that the petition presented substantial information indicating that the petitioned action may be warranted.

The Service has carefully assessed the best scientific and commercial information available regarding the present and future threats facing the California tiger salamander. Most of the remaining range of the California tiger

salamander is imminently threatened by urban development, conversion of natural habitat to agriculture, introduction of exotic predatory animals, and/or other anthropogenic factors (e.g., rodent control programs, vehicular-related mortality). However, several populations inhabiting refuges, parks, and other public lands are threatened only by exotic predators and stochastic events that may, in time, result in local extirpation. Moreover, tiger salamander localities in portions of the Diablo Range, inner Coast Ranges, and Sierra Nevada foothills are not significantly threatened at the present time. Coupled with the species' wide-ranging distribution (i.e., infrequently scattered population localities over 250 miles in 24 California counties) and relatively large number of remaining breeding localities, the species will not face extinction if recovery is temporarily postponed. Therefore, the Service concludes that the threats facing the species are moderate.

The Service concludes as a result of its status review that sufficient information is currently available to support a proposed rule to classify the species as endangered or threatened. According to Service policy announced in the *Federal Register* on May 12, 1993 (58 FR 28034), such species are placed in category 1 and assigned a listing priority number. Guidelines for assigning proper listing priorities were published in the *Federal Register* on September 21, 1983 (48 FR 43098). Consequently, given the moderate yet imminent threats facing the California tiger salamander throughout its range, the Service hereby assigns the California tiger salamander a listing priority number of 8.

For the current fiscal year that began on October 1, 1993, the Service in central and northern California is making expeditious progress to propose and list at least 49 high priority taxa (38 species in eight listing packages with a listing priority of 2, 9 species in four listing packages with a listing priority of

3, and 2 species in a listing package with a listing priority of 6). In light of these ongoing listing efforts involving plants and animals that are imminently and highly threatened, the Service finds the petition to be warranted but precluded by pending listing actions on higher priority species.

**Author**

The primary author of this document is Peter C. Sorensen (see ADDRESSES section).

**Authority**

The authority for this action is the Endangered Species Act of 1973, as amended (16 U.S.C. 1531-1544).

Dated: April 12, 1994.

**Mollie H. Beattie,**

*Director, Fish and Wildlife Service.*

[FR Doc. 94-9278 Filed 4-15-94; 8:45 am]

BILLING CODE 4310-55-P

# Notices

Federal Register

Vol. 59, No. 74

Monday, April 18, 1994

This section of the FEDERAL REGISTER contains documents other than rules or proposed rules that are applicable to the public. Notices of hearings and investigations, committee meetings, agency decisions and rulings, delegations of authority, filing of petitions and applications and agency statements of organization and functions are examples of documents appearing in this section.

## DEPARTMENT OF AGRICULTURE

### Rural Electrification Administration

#### Announcement of Applications Received Under the Distance Learning and Medical Link Grant Program

**AGENCY:** Rural Electrification Administration, USDA.

**ACTION:** Notice of applications received.

**SUMMARY:** The Administrator of the Rural Electrification Administration

(REA) is hereby announcing the applications received during the January 31, 1994; application filing deadline for the Distance Learning and Medical Link Grant Program.

**FOR FURTHER INFORMATION CONTACT:** Lawrence L. Bryant, Jr., Chief, Planning Branch, or Mark B. Wyatt, Chief, Finance Branch, Rural Development Assistance Staff, Rural Electrification Administration, telephone number (202) 720-1400.

**SUPPLEMENTARY INFORMATION:** REA is hereby publishing the names of the organizations which applied for grants under 7 CFR 1703 Subpart D, Distance Learning and Medical Link Grant Program.

These applications contained herein will be considered for funding during fiscal year (FY) 1994. Also to be considered for FY 1994 funding are applications submitted under the July

and October 1993 application filing periods, and those applications submitted under the April 1993 filing period which were previously considered for FY 1993 funding, but not selected. The notices which contain the lists of other applicants were published on December 21, 1993, and June 15, 1993, at 58 FR 67391 and 58 FR 33067, respectively. The total number of applications to be considered for funding during FY 1994 is 281. The total grant funds requested by the 281 applicants are \$88,359,205.

The amount awarded to any application selected for FY 1994 will not exceed \$500,000, as previously published on December 21, 1993, at 58 FR 67306.

The following information is being published in accordance with § 1703.115, Public notice of applications received. The applicants are as follows:

State	Applicant	Total grant \$ requested
AK	Copper Valley Economic Development Council	487,776
AL	Faulkner State Community College	500,000
AL	Troy State University at Troy	561,356
AR	Ozarks Unlimited Resources Educ. Cooperative	500,000
AR	St. Edward Mercy Medical Center	373,949
AR	University of Arkansas Cooperative Extension	480,286
AZ	Coconino County Superintendent of Schools	491,000
AZ	Kayenta Unified School District No. 27	497,100
CA	Chico Unified School District	22,500
CA	Redwoods Community College District	389,600
CA	Riverside County Department of Mental Health	77,363
CA	Siskiyou County Office of Education	53,415
FL	Dept. of Health & Rehabilitative Services	500,000
FL	Nemours Children's Clinic	159,700
FL	Okeechobee County School District	423,796
FL	University of South Florida	447,572
GA	Lowndes County Board of Health	496,726
HI	Hilo Family Practice Residency Program	500,000
HI	University of Hawaii	500,000
IL	Illinois Eastern Community Colleges	426,720
IL	Lee Center C.U.S.D. #271	500,000
IN	Indiana University	144,819
IN	Purdue University	499,853
IN	Saint Meinrad Archabbey	13,865
KS	Pittsburg State University	487,570
KS	Unified School District #281	282,930
KS	U.S.D. 481 Rural Vista	109,708
KS	Western Kansas Community Services Consortium	480,462
KY	The Life Connection, Inc	60,777
KY	Univ. of KY/Kentucky Cooperative Extension	46,800
KY	Warren County Board of Education	169,986
KY	Whitley County School System	500,000
ME	Eastern Maine Medical Center	442,313
MI	Baldwin Family Health Care, Inc	500,000
MI	District Health Department No. 3	135,035
MI	Munson Medical Center	115,680
MI	Southwest Michigan Pilot Network	500,000
MN	Mesabi Regional Medical Center	116,270
MO	Northwest Health Services, Inc	34,723

State	Applicant	Total grant \$ requested
MO	Rock Port R-II School	100,000
MO	Sparta R-III School District	223,965
MO	The Curators of the University of Missouri	494,214
MS	Coahoma County Board of Supervisors	500,000
MT	Montana State University	385,146
NE	Cambridge Memorial Hospital Association, Inc	478,000
NE	Educational Service Unit 15	480,426
NE	Nebraska Rural Development Commission	332,880
NH	NH Fiber Optic Network Cooperative	484,655
NH	University of New Hampshire	500,000
NM	Springer Municipal School District	239,988
NY	Herkimer County BOCES	458,640
OH	Hocking Technical College	247,230
OK	Southwest Educational Network (SW-EDNET)	500,000
OK	St. John Medical Center	500,000
OR	Central Linn School District	298,725
PA	Regional Development Corporation	116,250
SC	Richland Memorial Hospital	465,296
SD	South Dakota State University	31,880
TN	Johnson City Medical Center Hospital, Inc	410,197
TX	Dell City Independent School District	171,500
TX	Edgar B. Davis Memorial Hospital	12,120
TX	Kopperl I.S.D	144,000
UT	Northeastern Utah Education Services (NUES)	500,000
VA	SW Virginia Education & Training Network	476,400
VA	Tidewater Community College	488,268
WA	Eastern Washington University	487,844
WA	Orondo School District #13	208,384
WA	Republic School District #309	59,707
WI	Cambria-Friesland School District	32,000
WI	Randolph School District	31,440
WI	Southwest Wisconsin Library System	500,000
WI	Tri-County Memorial Hospital	63,711
WV	WV University Research Corporation	204,144
WY	Campbell County School District	383,229
WY	Community Hospital	164,309
WY	Northwest College	480,925

Authority: 7 U.S.C. 901 *et seq.* and 950aaa *et seq.*

Dated: April 12, 1994.

Wally Beyer,  
Administrator.

[FR Doc 94-9270 Filed 4-15-94; 8:45 am]

BILLING CODE 3410-15-F

#### COMMISSION ON CIVIL RIGHTS

##### Agenda and Notice of Public Meeting of the Michigan Advisory Committee

Notice is hereby given, pursuant to the provisions of the rules and regulations of the U.S. Commission on Civil Rights, that a meeting of the Michigan Advisory Committee to the Commission will be held from 9 a.m. until 5 p.m. on Tuesday, May 10, 1994, at the Westin Hotel, Renaissance Center, Detroit, Michigan 48243. The purpose of the meeting is to discuss current issues and plan future activities.

Persons desiring additional information, or planning a presentation to the Committee, should contact Committee Chairperson Janice G. Frazier at 312-259-8180 or Constance

M. Davis, Director of the Midwestern Regional Office, 312-353-8311 (TDD 312-353-8326). Hearing-impaired persons who will attend the meeting and require the services of a sign language interpreter should contact the Regional Office at least five (5) working days before the scheduled date of the meeting.

The meeting will be conducted pursuant to the provisions of the rules and regulations of the Commission.

Dated at Washington, DC, April 11, 1994.

Carol-Lee Hurley,

Chief, Regional Programs Coordination Unit.

[FR Doc. 94-9261 Filed 4-15-94; 8:45 am]

BILLING CODE 6335-01-P

##### Agenda and Notice of Public Meeting of the Minnesota Advisory Committee

Notice is hereby given, pursuant to the provisions of the rules and regulations of the U.S. Commission on Civil Rights, that a meeting of the Minnesota Advisory Committee to the Commission will be held from 9 a.m. until 5 p.m. on Friday, May 13, 1994, at the Crown Sterling Suites, 425 So. 7th

Street, Minneapolis, Minnesota 55415. The purpose of the meeting is to discuss current issues and plan future activities.

Persons desiring additional information, or planning a presentation to the Committee, should contact Committee Chairperson Karon Rogers at 612-661-4713, or Constance M. Davis, Director of the Midwestern Regional Office, 312-353-8311 (TDD 312-353-8326). Hearing-impaired persons who will attend the meeting and require the services of a sign language interpreter should contact the Regional Office at least five (5) working days before the scheduled date of the meeting.

The meeting will be conducted pursuant to the provisions of the rules and regulations of the Commission.

Dated at Washington, DC, April 11, 1994.

Carol-Lee Hurley,

Chief, Regional Programs Coordination Unit.

[FR Doc. 94-9262 Filed 4-15-94; 8:45 am]

BILLING CODE 6335-01-P

**DEPARTMENT OF COMMERCE****Bureau of Export Administration****Regulations and Procedures Technical Advisory Committee; Partially Closed Meeting**

A meeting of the Regulations and Procedures Technical Advisory Committee will be held May 5, 1994, at 9 a.m., in the Herbert C. Hoover Building, room 1617M(2), 14th Street and Pennsylvania Avenue NW., Washington, DC. The Committee advises the Office of Technology and Policy Analysis on implementation of the Export Administration Regulations (EARS), and provides for continuing review to update the EARS as needed.

**Agenda****General Session**

1. Opening remarks by the Chairman
2. Presentation of papers or comments by the public
3. State Department update on COCOM and other issues
4. BXA general update on major issues and reorganization
5. Export Administration Act status report
6. Enhanced Proliferation Control Initiative clarification
7. Regulations simplification (advisory opinions)

**Executive Session**

8. Discussion of matters properly classified under Executive Order 12356, dealing with the U.S. and COCOM control program and strategic criteria related thereto

The General Session of the meeting will be open to the public and a limited number of seats will be available. To the extent that time permits, members of the public may present oral statements to the Committee. Written statements may be submitted at any time before or after the meeting. However, to facilitate the distribution of public presentation materials to the Committee members, the Committee suggests that presenters forward the public presentation materials two weeks prior to the meeting date to the following address: Ms. Lee Ann Carpenter, TAC Unit/OAS/EA, Room 3886C, Bureau of Export Administration, U.S. Department of Commerce, Washington, DC 20230.

The Assistant Secretary for Administration, with the concurrence of the delegate of the General Counsel, formally determined on January 18, 1993, pursuant to section 10(d) of the Federal Advisory Committee Act, as amended, that the series of meetings or portions of meetings of the Committee

and of any Subcommittees thereof, dealing with the classified materials listed in 5 U.S.C. 552b(c)(1) shall be exempt from the provisions relating to public meetings found in section 10 (a)(1) and (a)(3), of the Federal Advisory Committee Act. The remaining series of meetings or portions thereof will be open to the public.

A copy of the Notice of Determination to close meetings or portions of meetings of the Committee is available for public inspection and copying in the Central Reference and Records Inspection facility, room 6020, U.S. Department of Commerce, Washington, DC. For further information, call Lee Ann Carpenter at (202) 482-2583.

Dated: April 13, 1994.

Lee Ann Carpenter,  
Acting Director, Technical Advisory  
Committee Unit.

[FR Doc. 94-9303 Filed 4-15-94; 8:45 am]

BILLING CODE 3510-07-M

**International Trade Administration**

[C-475-812]

**Final Affirmative Countervailing Duty Determination: Grain-Oriented Electrical Steel From Italy**

AGENCY: Import Administration, International Trade Administration, Department of Commerce.

EFFECTIVE DATE: March 18, 1994.

FOR FURTHER INFORMATION CONTACT: Annika L. O'Hara or David R. Boyland, Office of Countervailing Investigations, Import Administration, U.S. Department of Commerce, room 3099, 14th Street and Constitution Avenue NW., Washington, DC 20230; telephone (202) 482-4198 and (202) 482-0588, respectively.

FINAL DETERMINATION: The Department determines that benefits which constitute subsidies within the meaning of section 701 of the Tariff Act of 1930, as amended ("the Act"), are being provided to manufacturers, producers, or exporters in Italy of grain-oriented electrical steel. For information on the estimated net subsidy, please see the *Suspension of Liquidation* section of this notice.

**Case History**

Since the publication of the preliminary determination in the *Federal Register* on February 1, 1994 (59 FR 4682), the following events have occurred.

We conducted verification of the responses submitted on behalf of the Government of Italy ("GOI"), ILVA S.p.A. ("ILVA"), and the European

Community ("EC") from February 7 through February 21, 1994.

On March 22 and March 28, 1994, we received case and rebuttal briefs, respectively, from petitioners and respondents. Neither petitioners nor respondents requested a hearing in this investigation.

On March 29, 1994, we returned to petitioners certain factual information submitted in their briefs because it was untimely pursuant to § 355.31(a)(i) of the Department's regulations.

**Scope of Investigation**

This investigation concerns the following class or kind of merchandise: grain-oriented electrical steel ("electrical steel") from Italy.

The product covered by this investigation is grain-oriented silicon electrical steel, which is a flat-rolled alloy steel product containing by weight at least 0.6 percent of silicon, not more than 0.08 percent of carbon, not more than 1.0 percent of aluminum, and no other element in an amount that would give the steel the characteristics of another alloy steel, of a thickness of no more than 0.56 millimeter, in coils of any width, or in straight lengths which are of a width measuring at least 10 times the thickness, as currently classifiable in the Harmonized Tariff Schedule ("HTS") under item numbers 7225.10.0030, 7226.10.1030, 7226.10.5015, and 7226.10.5065. Although the HTS subheadings are provided for convenience and Customs purposes, our written description of the scope of this proceeding is dispositive.

**Injury Test**

Because Italy is a "country under the Agreement" within the meaning of section 701(b) of the Act, the U.S. International Trade Commission ("ITC") is required to determine whether imports of electrical steel from Italy materially injure, or threaten material injury to, a U.S. industry. On October 12, 1993, the ITC preliminarily determined that there is a reasonable indication that an industry in the United States is being materially injured or threatened with material injury by reason of imports from Italy of the subject merchandise (58 FR 54168, October 20, 1993).

**Corporate History of Respondent ILVA**

Prior to 1987, electrical steel in Italy was produced by Terni S.p.A. ("Terni"), a main operating company of Finsider. Finsider was a government-owned holding company which controlled all state-owned steel companies in Italy. In a restructuring of the Italian steel industry in 1982, Terni took over two

plants, Lovere and Trieste, from Nuova Italsider, another Finsider-owned steel producer.

As part of a subsequent restructuring in 1987, Terni transferred its assets to a new company, Terni Acciai Speciali ("TAS") which thereafter held all the assets for electrical steel production in Italy. As part of the restructuring, Lovere and Trieste became TAS' two principal subsidiaries.

In 1988, another restructuring took place in which Finsider and its main operating companies (TAS, Italsider, and Nuova Deltasider) entered into liquidation and a new company, ILVA, was formed. ILVA took over some of the assets and liabilities of the liquidating companies. With respect to TAS, part of its liabilities and the majority of its viable assets, including all the assets associated with the production of electrical steel, were transferred to ILVA on January 1, 1989. ILVA itself became operational on that same day. Part of TAS' remaining assets and liabilities were transferred to ILVA on April 1, 1990. After that date, TAS no longer had any manufacturing activities. Only certain non-operating assets (e.g., land, buildings, inventories), remained in TAS.

From 1989 to 1994, ILVA consisted of several operating divisions. The Specialty Steels Division, located in Terni, produced the subject merchandise. ILVA was also the majority owner of a large number of separately incorporated subsidiaries. The subsidiaries produced various types of steel products and also included service centers, trading companies, an electric power company, etc. ILVA together with its subsidiaries constituted the ILVA Group. The ILVA Group was owned by the Istituto per la Ricostruzione Industriale ("IRI"), a holding company wholly-owned by the GOI.

As of January 1, 1994, ILVA entered into liquidation and its divisions formed three companies. ILVA's former Specialty Steels Division is now a separately incorporated company, Acciai Speciali Terni, which produces electrical steel.

#### Spin-Offs

ILVA sold several "productive units," as defined in the General Issues Appendix to the Final Affirmative Countervailing Duty Determination: Certain Steel Products from Austria ("GIA"), 58 FR 37225, 37265-8 (July 9, 1993), from 1990 through 1992. At verification, we established that one of the companies had been sold to a government entity and one other company had been sold by Italsider

rather than ILVA. Our spin-off methodology does not apply in these situations. For the other companies, *i.e.*, those sold to private parties, we have applied the pass-through methodology described in the GIA to calculate the proportion of subsidies received by ILVA that "left" the company as a result of the sales of these productive units.

#### Period of Investigation

For purposes of this final determination, the period for which we are measuring subsidies (the period of investigation ("POI")) is calendar year 1992. We have calculated the amount of subsidies bestowed on the subject merchandise by cumulating benefits provided to Terni, TAS and ILVA from 1978 through 1992.

#### Analysis of Programs

Based on our analysis of the petition, the responses to our questionnaires, verification, and comments by interested parties, we determine the following.

#### Equityworthiness

Pursuant to section 355.44(e)(1) of the Proposed Regulations (Countervailing Duties; Notice of Proposed Rulemaking and Request for Public Comments ("Proposed Regulations"), 54 FR 23366, May 31, 1989), we preliminarily determined that Terni, TAS, and ILVA were unequityworthy from 1978 through 1992, except in 1979, 1983, 1988, and 1989 when equity infusions were not an issue. From the perspective of a reasonable private investor examining the firm at the time of the equity infusions, neither Terni, TAS, nor ILVA showed an ability to earn a reasonable rate of return over a reasonable period of time. We did not learn anything at verification that would lead us to reverse this finding.

As we stated in the preliminary determination, the companies which were restructured to form ILVA sustained losses from 1978 onward. Although ILVA had a brief period of operating profits for 1989 through 1991, its return on equity during this period declined until there was a negative return. Terni and ILVA's debt to equity ratios were relatively high. Read in conjunction with other financial indicators, such as net losses for numerous years, negative rates of return on equity and sales, the companies' financial performance was weak. Given this, we continue to find that Terni, TAS, and ILVA were unequityworthy from 1978 through 1992. Because the companies received no equity infusions during 1979, 1983, 1989, and 1990, we did not determine equityworthiness for

those years. (See also Memorandum to Director of Accounting dated April 11, 1994 on file in Room B-099 of the Main Commerce Building concerning the Department's evaluation of Terni's, TAS', and ILVA's equityworthiness.)

For the preliminary determination, we did not include 1988 in our equityworthy analysis because petitioners did not allege an infusion had occurred in that year and we were not aware of any such investment. However, in our review of ILVA's annual reports at verification, we learned that IRI contributed capital to ILVA in 1988 in the form of an equity infusion. Therefore, in accordance with § 355.44(e)(2) of the Proposed Regulations, we have considered whether ILVA was equityworthy in that year to determine whether the equity infusion was made on terms inconsistent with commercial considerations. As explained below, we have determined that ILVA was not equityworthy in that year.

#### Creditworthiness

Pursuant to section 355.44(b)(6)(i) of the Proposed Regulations, we preliminarily determined that Terni, TAS, and ILVA were uncreditworthy, *i.e.*, that they did not have sufficient revenues or resources to meet their costs and fixed financial obligations, from 1978 through 1992. In making that determination, we examined Terni's, TAS', and ILVA's current, quick, times interest earned and debt to equity ratios. We determined, for example, that the companies' times interest earned ratios were anemic for approximately 16 years, indicating a weak long-term solvency. Furthermore, the debt to equity ratios for both Terni and ILVA were relatively high.

We did not learn anything at verification that would lead us to reconsider our preliminary determination. Therefore, we continue to find that Terni, TAS, and ILVA were uncreditworthy from 1978 through 1992. (See also Memorandum to Director of Accounting dated April 11, 1994, on file in Room B-099 of the Main Commerce Building concerning the Department's evaluation of Terni's, TAS', and ILVA's creditworthiness.)

#### Benchmarks and Discount Rates

For uncreditworthy companies, § 355.44(b)(6)(iv)(A)(1) of the Proposed Regulations directs us to use, as the benchmark interest rate, the highest long-term fixed interest rate commonly available to firms in the country plus an amount equal to 12 percent of the prime rate. Because we were unable to obtain information on the highest long-term

interest rate commonly available in the country, we used the Bank of Italy reference rate which is the highest average long-term fixed interest rate we were able to verify. We then added to this rate an amount equal to 12 percent of the Italian Bankers Association ("ABI") prime rate. We have used the resulting interest rate as the benchmark for our long-term loans. In calculations where we have not used this rate, we have otherwise indicated. We have also used this amount as the discount rate for allocating over time the benefit from equity infusions and non-recurring grants for the same reasons explained in Final Affirmative Countervailing Duty Determination: Certain Steel Products From Spain, 58 FR 37374, 37376 (July 9, 1993).

#### Calculation Methodology

In determining the benefits to the subject merchandise from the programs described below, we used the following calculation methodology. We first calculated the benefit attributable to the POI for each countervailable program, using the methodologies described in each program section below. For those subsidies received by ILVA that were allocated over time, we then performed the pass-through analysis discussed in the GIA at 37269. The pass-through analysis accounts for any reduction in ILVA's subsidies that resulted from the sale of several productive units.

For the subsidies remaining with ILVA, we divided the benefit allocable to the POI by the sales of ILVA or the sales of the Specialty Steels Division of ILVA, depending on which company had received the benefit. (The program sections below indicate which denominator has been used for each program.) Next, we added the benefits for all programs, including the benefits for programs which were not allocated over time, to arrive at ILVA's total subsidy rate. Because ILVA is the only respondent company in this investigation, this rate equals the country-wide rate.

#### I. Programs Determined To Be Countervailable

##### A. Benefits Associated With the 1988-90 Restructuring

As discussed above under the "Corporate History" section of this notice, the GOI liquidated Finsider and its main operating companies in 1988 and assembled the group's most productive assets into a new operating company, ILVA. In 1990, additional assets and liabilities of TAS, Italsider, and Finsider went to ILVA.

In the preliminary determination, we found that a countervailable benefit was provided to ILVA through the 1988-1990 restructuring. In reaching this determination, we did not look at the transformation of Finsider as a whole into ILVA. Instead, we focused on the restructuring of TAS into the Specialty Steels Division of ILVA. We found that although TAS' net worth was negative prior to the restructuring, ILVA received a division with assets in excess of liabilities. In effect, TAS' balance sheet was rewritten so as to change its equity from negative 99,886 million lire to positive 317,836 million lire. For the preliminary determination, we treated the difference (417,722 million lire) as a countervailable benefit to ILVA.

We have reconsidered the methodology employed in the preliminary determination and have revised it for the final determination. We now believe that the approach taken in the preliminary determination understated the benefit to ILVA from the restructuring. It failed to take into account a portion of the liabilities not assumed by ILVA, that would otherwise have had to be repaid, and the losses incurred by TAS in connection with a write down of its assets in the restructuring process.

The purpose of the 1988-90 restructuring was to create a new, viable steel company (ILVA) by having it take over most of the productive assets of Finsider's operating companies like TAS, but only some of the liabilities. In April 1990, after all of TAS' manufacturing activities had either been transferred or shut down, TAS was nothing but a shell company in the process of liquidation, with liabilities exceeding its assets. ILVA, on the other hand, had received most of TAS' assets without being burdened by TAS' liabilities.

The liabilities remaining with TAS through the restructuring process had to be repaid, assumed, or forgiven. We have identified one specific instance of forgiveness. This occurred in 1989 when Finsider forgave 99,886 million lire of debt owed to it by TAS. Even with this forgiveness, TAS retained a substantial amount of liabilities after the 1990 transfer of assets and liabilities to ILVA. While no specific act eliminated this debt—indeed some of it is still outstanding—we believe that ILVA (and consequently the subject merchandise) received a benefit as a result of the debt being left behind in TAS.

In addition, we learned at verification that losses had been left behind in TAS, because the value of the assets transferred to ILVA had been written down. TAS gave up assets whose book

value was higher than their appraised value. As a result, TAS was forced to absorb losses. The loss from the first transfer was reflected as an extraordinary loss in TAS' 1988 Annual Report. With respect to the 1990 transfer, TAS had created a reserve in 1989 for the anticipated loss. At verification, we found that this loss was included in the liabilities that were left in TAS after the 1990 transfer.

In summary, in restructuring TAS into the Specialty Steels Division of ILVA, liabilities and losses due to asset write downs were left behind in TAS, a shell company. Although there was only one specific act of debt forgiveness, which only covered a portion of the liabilities in TAS, we believe that ILVA received a benefit when it was able to leave the debt and losses remaining in TAS. Because this benefit was specific to ILVA, we find a countervailable subsidy to ILVA in the amount of the debt and losses that should have been taken by ILVA when it took on the assets of TAS.

Treating these liabilities and losses as a subsidy to ILVA is consistent with the Department's determination in Certain Steel from Austria at 37221. In that case, we examined a government-owned operating company (VAAG) which was split up into numerous operating companies, one of which was subject to the investigation. In order to effect this split-up, the assets and liabilities of the original company were divided among the new companies. We determined that the creation of the new companies was merely a redistribution of existing assets which, in and of itself, did not give rise to any benefits. However, we also determined that a benefit arose because losses that had been incurred by VAAG were not distributed to the new companies. Therefore, we determined that the company under investigation effectively received a grant in the amount of the losses that should have been distributed to it.

Similarly, in the case of TAS and ILVA, the transfer of assets to ILVA is, in itself, a redistribution of assets which does not give rise to subsidies. However, a substantial portion of the liabilities and the losses associated with the assets were not distributed to ILVA. Instead, they remained behind in TAS. We are countervailing these amounts as grants to ILVA.

To calculate the benefit during the POI, we used our standard grant methodology (see section 355.49(b) of the Proposed Regulations). Finsider's 1989 forgiveness of TAS' debt and the loss resulting from the 1989 write down were treated as grants received in 1989. The second asset write down and the debt outstanding after the 1990 transfer

(adjusted as described below) were treated as grants received in 1990.

After the 1990 transfer, certain non-operating assets (e.g., land, buildings, inventories), remained in TAS. These assets are being disposed of in the liquidation process and the proceeds from the sale of the assets are available to pay off TAS' remaining liabilities.

In order to account for the fact that certain assets were left behind in TAS, we have adjusted the amount of liabilities outstanding after the 1990 transfer. We did this by writing down the value of the assets by taking a weighted average of the earlier write downs and subtracted this amount from the outstanding liabilities.

We then divided the benefits by ILVA's sales in the POI. On this basis, we determine the estimated net subsidy to be 12.10 *ad valorem* for all manufacturers, producers, and exporters in Italy of the subject merchandise.

#### B. Interest-Free Loans to ILVA

In 1992, ILVA received a 300 billion lire payment from IRI. At verification, we reviewed documents which established this payment as a "provisional" or "anticipated" capital increase. The reason that the payment was provisional was that before it could be considered as an equity infusion, authorization was needed from: (1) The shareholders, and (2) the EC.

IRI clearly intended that the money become share capital, as there were no arrangements for repayment (e.g., a repayment schedule), nor was interest to be paid. Therefore, as IRI was the sole shareholder in ILVA, its approval was a formality and the only real condition was the EC approval. If the EC approval was not received, the amount would have to be repaid to IRI. Although the GOI asked for the EC's approval, it was not granted during the POI.

ILVA's 1992 Annual Report shows that the company received a similar payment from IRI in 1991 which was entered in its accounting records in the same way as the 300 billion payment received in 1992. At verification, we learned that the background to the 1991 payment was the same as for the 1992 payment.

Because these payments were not converted to equity prior to the end of the POI, we cannot find the payments to be equity infusions. Thus, we have determined to treat the payments as short-term interest-free loans, which are being rolled over until such time as they are repaid or converted to equity upon EC approval.

The typical maturity in Italy for short-term loans is at most six months and roll-overs are common. In accordance

with § 355.44(b)(3)(i) of the Proposed Regulations, we used the 1992 International Monetary Fund's annualized "lending rate," converted to a semi-annual interest rate as the short-term benchmark interest rate. Since ILVA paid zero interest, the benefit to ILVA was the interest it would have owed on both payments. These benefits were then divided by ILVA's sales in the POI. On this basis, we determine the estimated net subsidy to be 0.49 percent *ad valorem* for all manufacturers, producers, and exporters in Italy of the subject merchandise.

#### C. Equity Infusions

The GOI, through IRI, provided new equity capital to Terni, TAS, or ILVA in every year from 1978 through 1991, except in 1979, 1983, 1989, and 1990. Respondents have not provided any argument refuting our preliminary determination that the GOI's equity investments were provided specifically to the steel industry.

As discussed above, we have determined that Terni, TAS, and ILVA were unequityworthy in each year that they received new equity capital. Therefore, these provisions of equity were inconsistent with commercial considerations and are countervailable.

To calculate the benefit for the POI, we treated each of the equity amounts as a grant and allocated the benefits over a 15-year period. (Our treatment of equity as grants and our choice of allocation period is discussed in the GIA, at 37239 and 37225, respectively.)

In the preliminary determination, we treated a capital increase received by ILVA in the amount of 205,097 million lire in 1990 as a countervailable equity infusion because ILVA reported it as an equity infusion in its responses. At verification, we established that the amount reported as an equity infusion was, in fact, due to the transfer of residual assets from Italsider, TAS, and Finsider, which were all in liquidation. As explained in connection with the 1988-1990 restructuring, we do not consider the transfer of assets in connection with a restructuring to be an "equity infusion" since the transfer merely redistributes existing assets. Therefore, we have excluded the amount of this capital contribution from our calculations.

For the equity infusions provided to Terni and TAS, we have divided the benefit allocated to the POI by the sales of the Specialty Steels Division of ILVA. We chose this sales denominator because this division most closely resembles the former companies, Terni and TAS. For equity infusions into ILVA, we used ILVA's sales as our

denominator, as benefits from these investments are not tied to any division of ILVA. On this basis, we find the estimated net subsidy to be 9.71 percent *ad valorem* for all manufacturers, producers, and exporters in Italy of the subject merchandise.

#### D. The Transfer of Lovere and Trieste to Terni in 1982

As discussed in the "Corporate History" section of this notice, Lovere and Trieste were transferred from Italsider to Terni as part of a 1982 restructuring.

We have determined that this transaction is correctly characterized as an internal corporate restructuring. No new equity capital was provided to Terni through the transfer of these assets. However, just as subsidies given to Terni and TAS continued to bestow a benefit on ILVA when ILVA received TAS' assets, subsidies received by Italsider flowed to Terni when Terni received Lovere and Trieste.

We determined the amount of Italsider's subsidies attributable to Lovere and Trieste by calculating the percentage of assets these two companies represented of the total Italsider assets. We applied this percentage to the "untied" subsidies received by Italsider to calculate the portion of the benefit that flowed to Terni when it received Lovere and Trieste.

The benefit allocated to the POI was divided by the total sales of the Specialty Steels Division of ILVA. On this basis, we find the estimated net subsidy to be 0.41 percent *ad valorem* for all manufacturers, producers, and exporters in Italy of the subject merchandise.

#### E. Law 675/77 Preferential Financing

Law 675/77 was designed to bring industrial assistance measures from the GOI under a single system. The program had at its core three main objectives: (1) the reorganization and development of the industrial sector as a whole; (2) the increase of employment in the South; and (3) the promotion of employment in depressed areas. To achieve these goals, Law 675/77 provided six types of benefits: (1) grants to pay interest on bank loans; (2) mortgage loans provided by the Ministry of Industry ("MOI") at subsidized interest rates; (3) other grants to pay interest on loans financed by IRI bond issues; (4) capital grants for the South; (5) VAT reductions on capital good purchases for companies in the South; and (6) personnel retraining grants. (The fourth, fifth, and sixth components of Law 675/77 are discussed below.)



As we stated in our preliminary determination, the GOI identified a number of different sectors as having received benefits under Law 675/77. These sectors were: (1) Electronic technology; (2) the mechanical instruments industry; (3) the agro-food industry; (4) the chemical industry; (5) the steel industry; (6) the pulp and paper industry; (7) the fashion sector; (8) the automobile industry; and (9) the aviation sector. Law 675/77 also sought to promote optimal exploitation of energy resources, and ecological and environmental recovery.

Despite the fact that Law 675/77 benefits were available to and used by numerous and varied industries, we preliminarily determined Law 675/77 benefits specific within the meaning of section 771(5)(A)(ii) of the Act, and therefore, countervailable because the steel industry was a dominant user pursuant to section 355.43(b)(2)(iii) of the Proposed Regulations. It received 34 percent of the benefits provided under the interest subsidy and capital grant components of the program.

The GOI has argued that the steel and automobile industries did not receive a disproportionate share of benefits when the extent of investment in those industries is compared to the extent of investment in other industries.

We did not consider the level of investment in the industries receiving benefits under Law 675/77. Instead, we followed the policy explained in Final Affirmative Countervailing Duty Determination: Certain Steel Products from Brazil, 58 FR 37295, 37295 (July 9, 1993), of comparing the share of benefits received by the steel industry to the collective share of benefits provided to other users of the program. Consistent with our determination in Final Affirmative Countervailing Duty Determination: Certain Steel Products from Italy ("Certain Steel from Italy"), 58 FR 37327 (July 9, 1993), we found that the steel industry accounted for 34 percent of the benefits and the auto industry accounted for 33 percent of the benefits. Thus, these two industries represented 77 percent of the assistance while the remainder was spread among the other seven industries.

On this basis, we determine that the steel industry was a dominant user of programs under Law 675/77 and, therefore, that benefits received by ILVA under this law are being provided to a specific enterprise or industry or group of enterprises or industries. Therefore, we find Law 675/77 financing to be countervailable to the extent that it is provided on terms inconsistent with commercial considerations.

#### 1. Grants to Pay Interest on Bank Loans

Italian commercial banks provided long-term loans at market interest rates to industries designated under Law 675/77. The interest owed by the recipient companies on these loans was offset by contributions from the GOI. Terni received bank loans with Law 675/77 interest contributions which were outstanding in the POI.

To determine whether this assistance conferred a benefit, we compared the effective interest rate paid on these loans to the benchmark interest rate, described above. Based on this comparison, we determine that the financing provided under this program is inconsistent with commercial considerations, *i.e.*, on terms more favorable than the benchmark financing.

Because Terni knew that it would receive the interest contributions when it obtained the loans, we consider the contributions to constitute reductions in the interest rates charged rather than grants (see Certain Steel from Italy at 37331).

Therefore, to calculate the benefit, we used our standard long-term loan methodology as described in § 355.49(c)(1) of the Proposed Regulations. We divided the benefit allocated to the POI by the sales of the Specialty Steels Division of ILVA. On this basis, we determine the estimated net subsidy to be 0.03 percent *ad valorem* for all manufacturers, producers, and exporters in Italy of the subject merchandise.

#### 2. Mortgage Loans from the Ministry of Industry Under Law 675/77,

companies could obtain long-term low-interest mortgage loans from the Ministry of Industry. Terni received several loans which were still outstanding in the POI.

To determine whether these loans were provided on terms inconsistent with commercial considerations, we used the benchmark interest rates described above. Because the interest rates paid on the Law 675/77 loans were below the benchmark interest rates, we determine that loans provided under this program are countervailable.

We calculated the benefit using our standard long-term loan methodology. We then divided the benefit allocated to the POI by the sales of the Specialty Steels Division of ILVA. On this basis, we determine the estimated net subsidy from this program to be 0.30 percent *ad valorem* for all manufacturers, producers, and exporters in Italy of the subject merchandise.

#### 3. Interest Contributions on IRI Loans/Bond Issues

Under Law 675/77, IRI was allowed to issue bonds to finance restructuring measures of companies within the IRI Group. The proceeds from the sale of the bonds were then re-lent to IRI companies. The effective interest rate on such loans was reduced by interest contributions made by the GOI. Terni had two of these loans outstanding during the POI. Both loans had variable interest rates.

To determine whether these loans were countervailable, the Department used a long-term variable rate benchmark as described in § 355.44(B) of the Proposed Regulations. We compared this benchmark rate to the effective rates paid by Terni in the years these loans were taken out and found that these loans were provided on terms inconsistent with commercial considerations.

To determine the benefit, we first calculated the difference between what was paid on these loans during the POI and what would have been paid during the POI had the loans been provided on commercial terms. We divided the resulting difference by the sales of the Specialty Steels Division of ILVA. On this basis, we determine the estimated net subsidy from this program to be 0.26 percent *ad valorem* for all manufacturers, producers, and exporters in Italy of the subject merchandise.

#### F. Urban Redevelopment Financing Under Law 181/89

Law 181/89 was implemented to ease the impact of employment reductions in the steel crisis areas of Naples, Taranto, Terni, and Genoa. The program had four main components: (1) reindustrialization projects; (2) job promotion; (3) training; and (4) early retirement. (Early retirement under Law 181/89 was not used by ILVA and the job promotion component has been found not countervailable (see relevant sections below).

Because benefits under this program are limited to specific regions, we determine that assistance under this program is limited to a group of industries in accordance with section 355.43(b)(3).

#### 1. Reindustrialization Under Law 181/89

Under the reindustrialization component of Law 181/89, the GOI partially subsidized certain investments. ILVA received payments under Law 181/89 for a training center to update the technical skills of its workers. Training also took place at this center to

improve workers' skills for employment outside the steel industry.

Since the information provided to the Department indicates that the center supported the training of steel workers who continued to be employed by ILVA, we determine that ILVA received a benefit from reindustrialization payments under Law 181/89.

In addition, we established that ILVA received payments under Law 181/89 for service centers. However, these service centers were involved in steel processing unrelated to electrical steel. Therefore, payments to these service centers were not included in our calculations.

To calculate the benefit to ILVA during the POI, we used our standard grant methodology (see § 355.49(b) of the Proposed Regulations) and the discount rate described above. It is the Department's practice to treat training benefits as recurring grants (see GIA at 37226).

Accordingly, we divided the amount received in the POI by the 1992 sales of the ILVA. On this basis, we determine the estimated net subsidy to be 0.00 percent *ad valorem* for all manufacturers, producers, and exporters on Italy of the subject merchandise.

## 2. Worker Training

Retraining grants were provided to ILVA under Law 181/89. These funds constituted the GOI's matching contribution to ECSC Article 56(2)(b) training grants (see ECSC Article 56 Redeployment Aid section below).

Since information provided at verification indicates that these funds were used to train workers remaining at ILVA, we determine that the GOI's training contribution under Law 181/89 constitutes a benefit to ILVA.

It is the Department's practice to treat training benefits as recurring grants (see GIA at 37226). Accordingly, we divided the amount received by the sales of the Specialty Steels Division of ILVA. On this basis, we determine the estimated net subsidy from this program to be 0.10 percent *ad valorem* for all manufacturers, producers, and exporters in Italy of the subject merchandise.

## G. ECSC Article 54 Loans

Under Article 54 of the 1951 ECSC Treaty, the European Commission can provide loans directly to iron and steel companies for modernization and the purchase of new equipment. The loans finance up to 50 percent of an investment project. The remaining financing needs must be met from other sources. The Article 54 loan program is financed by loans taken by the Commission, which are then re-lent to

iron and steel companies in the member states at a slightly higher interest rate than that at which the Commission obtained them.

ILVA had outstanding Article 54 loans in the POI. These loans were transferred to ILVA as part of the partial transfer of Terni's assets and liabilities in 1989. Two of these loans were denominated in U.S. dollars and two in European Currency Units ("ECU").

Because Article 54 loans are limited to iron and steel companies, we find these loans to be specific and, therefore, countervailable to the extent that they were provided on terms inconsistent with commercial considerations.

Because these loans were denominated in foreign currencies, we used foreign currency benchmarks for our preliminary determination.

However, the Article 54 loans had exchange rate guarantees that allowed Terni to calculate the maximum lire amount payable (see Law 796/76 Exchange Rate Guarantee Program described below). Since these loans were effectively insulated from any future changes in the exchange rate, we are not using foreign currency benchmark interest rates as we did in the preliminary determination. Rather we are using the uncreditworthy benchmark discussed in the *Benchmark and Discount Rate* section above.

At verification we found that one of the U.S. dollar loans had been assumed by Terni when it became the parent company of the original debtor. We are using the uncreditworthy benchmark interest rate for the year in which the loan was assumed by Terni in order to calculate the benefit from this loan, as that was the year in which Terni incurred the liability.

Because the interest rates paid on all the Article 54 loans were below the benchmark interest rates, we determine that the loans provided under this program are countervailable. We calculated the benefit using our standard long-term loan methodology. We then divided the benefit allocated to the POI by the sales made by the Specialty Steels Division of ILVA. On this basis, we determine the estimated net subsidy to be 1.02 percent *ad valorem* for all manufacturers, producers, and exporters in Italy of the subject merchandise.

## II. Programs Determined To Be Not Countervailable

### A. Early Retirement

In Certain Steel from Italy, we determined that the threat of strikes and social unrest prevented Italian steel companies from laying off surplus labor.

As a result, these companies were effectively obligated to retain their workers until the workers reached retirement age. Given this obligation, when the GOI created a program to allow for early retirement, we determined that the steel companies had been relieved of the burden of retaining these employees at full salary until the normal retirement age.

In the preliminary determination of this investigation, we relied on Certain Steel from Italy and determined that early retirement provided a countervailable benefit which we measured as the savings to ILVA arising from not having to pay wages to the workers who took early retirement in the POI.

At verification in this case, the GOI provided evidence showing that companies in Italy have the legal right to fire workers. Small companies (those with less than 15 employees) could simply eliminate surplus workers. Large companies, however, go through certain steps and procedures before they can lay workers off (other than for cause). The procedures and the benefits paid to employees laid off by these companies are provided for in Law 223/91.

Law 223/91 provides two means of removing surplus workers: early retirement and lay-offs under CIG-S.

### 1. Early Retirement

Early retirement is regulated in two separate articles of Law 223/91, both of which were used by ILVA workers in the POI. Each article has different eligibility criteria, but essentially the program is available to companies in high-technologies and competitive industries that are undergoing restructuring. Under both articles, the companies pay 30 percent of the early retirement benefits, while the GOI pays the rest. The GOI sets an annual cap on the number of workers that can be retired under this provision. In 1992, 21 percent of the quota was set aside for steel workers.

### 2. CIG-S

CIG-S (the extraordinary compensation fund) is also regulated by Law 223/91. CIG-S provides for lay-offs by companies that (1) are undergoing restructuring, (2) have more than 15 employees, and (3) belong to a wide range of industries. The GOI must approve use of this program, under which laid-off workers receive a certain percentage of their wages for three years. Thereafter, they may receive further compensation under a follow-up program (mobility). The GOI pays 80 percent and the companies 20 percent of the benefits.

In a meeting with a U.S. Embassy official at verification, we learned that approximately 25 percent of the Italian workforce is employed in companies eligible for the provisions under Law 223/91. The remaining 75 percent work for companies that do not have to offer their employees any benefits upon separation except the obligatory severance payment that is also paid to workers who take early retirement or are placed on the CIG-S. Employees in these smaller companies who are laid off receive only government-provided unemployment compensation.

ILVA, on the other hand, belongs to that category of companies (larger companies in structural and economic crisis), that have to undertake certain specific steps before actually getting rid of surplus labor. Therefore, the alternatives facing ILVA are early retirement and the permanent lay offs under CIG-S, provided under Law 223/91.

In determining whether worker benefits such as early retirement confer a subsidy on the company, we look to whether the company has been relieved of an obligation it would otherwise incur. (See section 355.44(j) of the Proposed Regulations.) In this instance, we find that, in the absence of the early retirement program, the obligation that would be incurred is that imposed by the alternative available to ILVA, the CIG-S program. We have found that large companies in a wide variety of industries that are undergoing restructuring can use the CIG-S program to lay off workers. Therefore, we believe that this program establishes the benchmark for the obligations ILVA would otherwise have towards the workers it retires early.

Based on the information we have received, we have not been able to make an exact comparison of the financial obligations ILVA would incur under CIG-S as opposed to the early retirement scheme. Because the benefits paid to a worker under early retirement can extend from one to more than ten years (whereas CIG-S payments are limited to three years) and because the percentage paid by the company is based on different amounts (the worker's pension, which varies from worker to worker, for early retirement and the worker's salary for CIG-S), we are doubtful that exact comparisons can be made. However, we have used the information we have and made certain limited assumptions to calculate the financial obligations on ILVA imposed by early retirement exceed the financial obligations that would be imposed by CIG-S. (See Memorandum from Team to Barbara R. Stafford dated April 11, 1994

on file in room B-099 of the main Commerce Building.) Therefore, we find that the early retirement program is not countervailable.

#### *B. Law 796/76 Exchange Rate Guarantee Program*

This program applies to foreign currency loans taken out by Italian companies. Under the program, repayment amounts are calculated by reference to the exchange rate in effect at the time the loan is taken out. If the exchange rate changes over time, the program sets a ceiling and a floor to limit the effect of the exchange rate change on the borrower. For example, if the lire depreciates five percent against the DM (the currency in which the loan is taken out), borrowers would normally find that they would have to repay five percent more (in lire terms). However, under the Exchange Rate Guarantee Program, the ceiling would act to limit the increased repayment amount to two percent. There is also a floor in the program which would apply if the lire appreciated against the DM. The floor would limit any windfall to the borrower.

In the preliminary determination (as in Certain Steel), we found this program to be *de jure* specific because we believed the program was limited to ECSC loans. However, we discovered at the verification in this investigation that we had overlooked information in the response which indicated that guarantees under this program were also available for loans made by the Council of Europe Resettlement Fund ("CER"). We attempted to learn more about the program's *de facto* specificity at verification as it became clear that the program was not *de jure* specific.

We established that exchange rate guarantees for CER loans are provided for in Law 796, the same law that provides guarantees for ECSC loans. We learned that CER loans are designed to improve social conditions in the weakest sectors of society by providing loans to small- and medium-sized businesses to create employment opportunities. Officials named the following examples of areas/activities that receive funds from the CER: agriculture, handicraft, tourism. We examined certain loan documents and established that guarantees were in effect on CER loans. However, given the limited time and the manner in which the data were organized, Italian officials were not able to provide information regarding the distribution of benefits provided to CER and ECSC borrowers.

Based on the information we have, the exchange risk guarantees may be non-specific. Moreover, we cannot draw

adverse inferences regarding the distribution of benefits under the program because the GOI was not uncooperative or otherwise remiss in providing the requested data. Therefore, we determine that the program is not countervailable.

Given the circumstances under which we have reached this determination, *i.e.*, lacking certain important information, this finding of non-countervailability will not carry over to future investigations. Therefore, until a fuller record is developed which allows us to undertake a thorough analysis, petitioners will not have to provide new evidence in order for us to investigate this program. In addition, we intend to reinvestigate this program in the first administrative review requested should this investigation result in a countervailing duty order.

#### *C. Finsider Loan Guarantees*

Certain loans made to Terni were assumed by ILVA, and were still outstanding during the POI. At the time the loans were taken out they were guaranteed by Finsider, the holding company of Terni and then TAS. Finsider entered into liquidation in 1988. Nevertheless, ILVA continued to pay the guarantee fees for these loans to Finsider until 1991. At that time, ILVA ceased to pay guarantee fees to Finsider and, in essence, "self-guaranteed" these loans.

Petitioners argue that the Department should countervail these loan guarantees because: (1) The fees paid for the guarantees were less than what would have been paid to a commercial guarantor; and (2) guarantees to Terni, an uncreditworthy company, constitute government intervention ensuring the extension of the loans.

Although information obtained at verification indicates that ILVA paid Finsider less than it would have paid a commercial guarantor, we have concluded that ILVA received no benefit. Given that Finsider was in liquidation and presumably could not have carried out the guarantee, ILVA was receiving nothing in exchange for its payments. Therefore, we find that these loan guarantees are not countervailable.

#### *D. Interest Grants for "Indirect Debts" Under Law 750/81*

At verification, we established that Law 750/81 was passed as a result of the 1981 Iron and Steel plan to provide interest grants to sectors within the steel industry which were designated as strategic sectors. The program was in place from 1981 through 1983.

One of the sectors designated as a strategic sector was forgings and castings, as these steel products were used in the construction of electrical power plants. Since Terni was the only producer of this type of forgings and castings, the GOI provided assistance to Terni to allow it to reach full production capacity.

Because these benefits were provided for the production of forgings and castings, we determine that they do not provide a benefit to the subject merchandise.

#### E. ECSC Article 56 Redeployment Aid

Under Article 56(2)(b) of the ECSC Treaty, redeployment assistance is provided to workers affected by the restructuring of the coal and steel industries in the ECSC member states. The assistance consists of the following types of grants: (1) Income support grants for workers affected by unemployment, re-employment at a lower salary or early retirement; (2) grants to enable companies to continue paying workers who have been laid off temporarily; (3) vocational training grants; and (4) resettlement grants. The decision to grant Article 56 assistance is contingent upon a matching contribution from the member state.

The portion of Article 56 redeployment grants funded by the ECSC comes from the European Commission's operational budget for the ECSC steel program. This budget is funded by (1) levies imposed on coal and steel producers in the member countries; (2) income from ECSC's investments; (3) guarantee fees and fines paid to the ECSC; and (4) interest received from companies that have obtained loans from the ECSC.

Because payments from the ECSC under Article 56 are sourced from producer levies, we find them to be not countervailable (see *Certain Steel from Italy* at 37336). (The matching contributions from the GOI for the training elements of Article 56 were discussed above under Law 181/89.)

#### F. European Social Fund ("ESF") Grants

The ESF was established by the 1957 European Economic Community Treaty to increase employment and help raise the living standards of workers.

We find in *Certain Steel from Italy* that the ESF receives its funds from the EC's general budget, whose main revenue sources are customs duties, agricultural levies, value-added taxes collected by the member states, and other member state contributions.

The member states are responsible for selecting the projects to be funded by the EC. The EC then disburses the grants

to the member states which manage the funds and implement the projects. According to the EC, ESF grants are available to (1) people over 25 who have been unemployed for more than 12 months; (2) people under 25 who have reached the minimum school-leaving age and who are seeking a job; and (3) certain workers in rural areas and regions characterized by industrial decline or lagging development.

ESF grants received by Italy were used for two purposes: (1) training laid-off employees for jobs outside the sector in which they had previously been working; and (2) training of workers to perform new jobs within the same company.

Every region in Italy has received ESF funds. Therefore, we determine that this program is not regionally specific within the meaning of § 355.43(b)(3) of the Proposed Regulations. Furthermore, we note that to the extent there is any disproportionality in the regional distribution of ESF benefits (i.e., to the regions of southern Italy), it has not resulted in a countervailable benefit to the production of the subject merchandise, which is produced in northern Italy.

#### G. Aid Under the National Research Plan

In 1985, the Ministry for University, Technology and Scientific Research assigned 19 billion lire to Terni under the National Research Plan for steel. The research funds covered costs of personnel assigned to specific research projects in research laboratories. The research under this plan was contracted out to Terni as the result of a competitive bidding process.

At verification, we established that the assistance under the National Research Plan was provided under Law 46/82. Under the same law, the GOI has supported similar research plans for 17 other industries or sectors. Moreover, documentation provided by the GOI showed that the steel industry did not receive a disproportionate share of the funds provided for research plans.

Thus, we determine that benefits under the program are not limited to a specific enterprise or industry or group of enterprises or industries. Therefore, we find this program to be not countervailable.

#### H. Job Promotion Under Law 181/89

The job promotion component of Law 181/89 involved a number of measures designed to promote self-employment among workers in Naples, Taranto, Terni, and Genoa. These measures included, among others, assisting former workers in starting their own

businesses, providing specialized management training, and increasing the level of financing available to new businesses. In general, these measures were coordinated by an IRI-owned company, *Societa Finanziaria di Promozione e Sviluppo Imprenditoriale*.

Based on the information provided at verification, we determine that the "job promotion" component of Law 181/89 provides for workers leaving the steel industry. Moreover, there is no indication that ILVA (or other companies in Italy) had an obligation, legal or otherwise, to provide assistance to workers leaving the steel industry. Therefore, we determine that ILVA did not receive a benefit from assistance provided under the job promotion component of Law 181/89.

#### III. Programs Which Were Not Used or Which Did Not Benefit the Subject Merchandise in the POI

A. We established at verification that the following programs were not used during the POI.

1. *Subsidized Export Financing Under Law 227/77*
2. *Early Retirement Provision under Law 181/89*
3. *Personnel Retraining Grants under Law 675/77*

B. We established at verification that loans provided under the following programs were not outstanding in the POI.

1. *Finsider Loans*
2. *Interest Subsidies under Law 617/81*
3. *Financing under Law 464/72*

C. We established at verification that the following programs were directed to the South of Italy. Since production of the subject merchandise takes place outside the South, we determine that these programs did not benefit the subject merchandise.

1. *Law 675/77 Capital Grants*
2. *Reductions of the Value Added Tax ("VAT") under Law 675/77*
3. *Interest Contributions under the Sabatini Law (Law 1329/65)*
4. *Social Security Exemptions*
5. *ILOR and IRPEG Exemptions*

#### Interested Party Comments

##### Comment 1

Petitioners argue that the Department's preliminary decision to measure subsidization by a comparison of TAS' equity before and after restructuring, which they labeled the "snapshot" approach, was improperly substituted for, and contrasts sharply with, the cash flow approach the Department has historically used to measure subsidies. Petitioners allege

that by focusing only on the differences in TAS' balance sheet at two different points in time, to the exclusion of a review of the intermediate activities undertaken by the GOI to bestow funds on ILVA, the Department ignored the full measure of debt forgiveness and other assistance provided to ILVA.

Petitioners also argue that the problem with the Department's approach is that it ignored the sizeable liabilities and negative equity position left behind in the "empty shell" of TAS which were brought about by the restructuring as a result of the artificial separation of TAS' assets and liabilities. Petitioners maintain the Department's approach focuses exclusively on net changes in equity, regardless of the individual transactions that caused the changes which would have been captured in a cash flow analysis. According to petitioners, the only way to accurately measure the subsidies provided to Terni/TAS is to identify and measure the value of each individual transaction, be it a grant, equity infusion, debt forgiveness, or loss coverage.

Respondents contend that the Department should exclude from the calculation of any countervailable subsidy any of the TAS assets transferred to ILVA or assets remaining in TAS. In addition, respondents argue that changes in TAS' equity position resulting from the official appraisal of assets and liabilities conferred no countervailable benefit to ILVA. Furthermore, according to respondents, assets and liabilities remaining in TAS could not have conferred a countervailable benefit to ILVA. Finally, respondents argue that § 355.48 of the Proposed Regulations explicitly provides for a departure from the cash flow methodology in "unusual circumstances." Respondents argue that it would be unreasonable to review each of the transactions as suggested by petitioners because of the extreme complexity of the transactions involved in this case. Respondents maintain the Department has performed a transaction-specific analysis wherever practicable.

#### *DOC Position*

Insofar as our preliminary determination focused on the change in the net equity position of TAS, it failed to account for certain liabilities and losses left behind in TAS. In this final determination, we have addressed this shortcoming. We recognize that the restructuring resulted in TAS holding liabilities and absorbing losses, and that those liabilities and losses would somehow have to be covered. As ILVA

would not be covering them, ILVA received a benefit in that amount.

However, we disagree with petitioners that the so-called snapshot approach cannot be substituted for the cash flow approach traditionally used by the Department. First, our approach in this final determination is consistent with the methodology used to assess countervailable benefits arising out of restructuring in Certain Steel from Austria. Second, it fully and accurately measures the benefits conferred on the production of the subject merchandise. Finally, petitioners misuse the concept of the cash flow effect.

As explained above, in Certain Steel from Austria, when the company producing steel was restructured, we found that a benefit to the new company arose because the new company did not receive any of the losses accumulated by the former company. There was no specific act of payment or loss coverage undertaken by the Government of Austria to eliminate those losses as part of the restructuring. Instead, the losses were simply left behind in the former company. In Certain Steel from Austria, these losses left in the "shell" company were determined to be countervailable.

Similarly, in the case of restructuring TAS into the Specialty Steels Division of ILVA, the liabilities and losses left behind in TAS have been found to give rise to a benefit to ILVA. There was one specific act of debt forgiveness between Finsider and TAS. That was accounted for in our calculations, but only as a part of the totality of the restructuring action.

We further believe that the snapshot approach has fully captured the benefit to the subject merchandise. Based primarily on the annual reports of IRI, Finsider and TAS, petitioners have developed a long list of "subsidies" that include IRI's forgiveness of Finsider's debt and numerous and varied forms of payments to TAS throughout and subsequent to the restructuring. We have concluded that countervailing subsidies from IRI to Finsider and from Finsider to TAS would lead to an overstatement of the benefit. (See DOC response to Comment 2.)

With respect to the subsidies received by TAS after the second asset transfer to ILVA (e.g., interest paid to TAS on its shares in ILVA, capital gain on real estate received by TAS, etc.), we recognize that these payments did, in fact, reduce the liabilities in TAS. However, because we included in the restructuring benefit the amount of liabilities remaining in TAS after the second transfer, we have already captured the benefits from these subsidies.

This is similar to the situation that occurred in Certain Steel from Austria. As discussed above, we treated as a subsidy the amount of losses left behind in the former company, without regard to whether there was a specific act by the government to cover those losses. In fact, the Government of Austria did make a payment a few years later to that company. Recognizing that the second transaction was basically to clean up the company's books for an event that had occurred earlier (the failure to transfer losses), we did not countervail the payment by the Government of Austria as it would have amounted to double-counting.

Finally, petitioners misuse the concept of cash flow effect when they argue that this concept prohibits us from using a snapshot approach. Cash flow effects do not identify subsidies. Instead, the cash flow concept tells us when to assign the benefit from a particular subsidy. For example, the cash flow concept tells us to assign the benefits received from a subsidized loan to the point in time when the company would have made the interest payment because this is when the company's cash flow is affected. In this case, the effect on ILVA of not assuming TAS' liabilities and losses occurred when the assets were transferred, in 1989 and 1990, and we have assigned the benefits to these years.

#### *Comment 2*

Petitioners argue that the Department did not directly address the question of the benefit to the Finsider group as a whole, and through the Finsider group to TAS, of a multi-billion lire debt forgiveness provided in connection with the 1988/90 steel industry restructuring. The only debt forgiveness that was included in the Department's preliminary calculations was the 99.9 billion lire in debt forgiveness provided to TAS.

Petitioners claim that the Department should countervail a debt forgiveness in the amount of 6.2 trillion lire to the Finsider Group in 1988 and allocate the resulting benefit over a sales denominator reflecting the scope of operations of the Finsider companies that were liquidated and merged into ILVA. Moreover, petitioners argue that the Department should countervail the 99.9 billion lire debt forgiveness provided specifically to TAS in 1989 as a separate benefit.

Respondents argue that petitioners have failed to establish that the forgiveness of Finsider's debt is tied to the subject merchandise. Respondents argue that the 1988 debt forgiveness to Finsider pre-dates the restructuring of

Finsider into ILVA by nearly one year. Thus, Finsider at the time of the debt forgiveness was not the same company as it was when its assets were transferred into ILVA. Respondents maintain that Finsider and TAS existed and functioned as two separate corporate entities and, therefore, argue that TAS was never potentially responsible for the assumption of Finsider's debt. Respondents assert that only the 99.9 billion lire debt forgiveness provided directly to TAS should be treated as a countervailable debt forgiveness.

#### DOC Position

In the early stages of this investigation, it became clear to us that there were two alternative approaches to addressing the allegations in the petition regarding subsidies to the producers of electrical steel. One approach would have been to analyze the restructuring of the entire Finsider group into ILVA and to examine all subsidies provided to Finsider by IRI and the GOI. Using this approach we would, in essence, be measuring subsidies provided to the Finsider group as a whole. Therefore, we would not have allocated subsidies to any of the group's operating companies, such as TAS.

The second approach would measure the subsidies provided to the producer of the subject merchandise. In other words, our analysis would focus on subsidies such as equity infusions, loans, and grants specifically provided to the producer of the subject merchandise, *i.e.*, Terni/TAS and the Specialty Steels Division of ILVA.

We chose the second approach for several reasons. First, it is the Department's policy to try to "tie" subsidies to the subject merchandise whenever possible (see GIA at 37267). Second, since the Finsider group was very large, consisting of numerous state-owned steel producers, only one of which produced the subject merchandise, we believed it would be more appropriate to focus our analysis on the producer of the subject merchandise. Finally, due to the extremely complex restructuring which occurred at the Finsider group level, we felt we would be able to more accurately measure the subsidies provided to the producer of the subject merchandise by following the second approach.

Petitioners have argued that the Department should countervail the subsidies emanating from the debt forgiveness provided to Finsider. Petitioners also argue that we should countervail the 99.9 billion lire debt forgiveness provided to TAS as well.

However, countervailing both instances of debt forgiveness would overstate the benefit to TAS because we would then be looking at the forgiveness from two different levels of analysis at the same time. As stated in the verification reports, the 99.9 billion debt forgiveness to TAS was part of the larger debt forgiveness provided to Finsider. Therefore, in order to be consistent with the approach chosen in this investigation, *i.e.*, to focus on the producer of the subject merchandise, we are countervailing only the debt and loss forgiveness provided to TAS.

#### Comment 3

Petitioners argue that the 300 billion lire payment from IRI to ILVA in 1992 should be countervailed as an equity infusion and not as an interest-free loan. Petitioners maintain that this capital contribution in 1992 was called an "interest free loan" because, at that time, it had not been expressly approved as an equity infusion. Also, petitioners point to the fact that there was no loan agreement. Petitioners maintain that the Department should not base its decision on "technicalities" such as the EC's delayed approval and the continued absence of a shareholders' decision approving a capital increase. Petitioners conclude that since the Department determined at verification that the EC has recently sanctioned this amount as an equity infusion, the Department should treat it as such.

Petitioners also argue that the 10,900 million lire "payment on capital account" to ILVA in 1991, which the Department found at verification, should be countervailed as an equity infusion. The nature of this payment was identical to that of the 1992 payment. Respondents argue that the Department's verification confirmed that this 1992 infusion was a liability as opposed to an equity infusion. Additionally, respondents state that there were two conditions which had to be met before the 1992 capital contribution could be considered an equity infusion: (1) Authorization from the EC; and (2) authorization from the company's shareholder. Neither of these two conditions was met during the POI and the amount was considered a "provisional capital increase." Thus, the Department properly recognized the legal limitations placed on this fund and, treated it as a short-term loan.

Respondents state that EC's preliminary approval of the capital contribution in 1993 did not occur until nearly a year and a half after the POI. Citing Countervailing Duty Determinations: Certain Steel Products from France ("Certain Steel from

France"), 58 FR 37313 (July 9, 1993), respondents argue that it is the reclassification of debt into equity which itself constitutes the potentially countervailable event in this case. According to respondents, since the potentially countervailable event took place after the POI, it is not subject to analysis in this investigation.

#### DOC Position

Based on an analysis of the primary features of the 1991 and 1992 provisional capital contributions, we find that the potential obligation to repay IRI (in the event that the EC did not approve the capital contribution) effectively makes these contributions contingent liabilities. To reflect their contingent nature, we have modelled the provisional capital contributions as short-term zero-interest loans which are rolled over every six months until such time as they are repaid or the EC approves their conversion to equity.

We disagree with respondents that Certain Steel from France is applicable in this instance. In the French case, we were looking at the year the debt-to-equity conversion occurred and decided that the equity infusion was the potentially countervailable event rather than the loan. In this case, the provisional capital increase is being treated as a loan throughout the POI. Therefore, there is no other potentially countervailable event in the POI.

We disagree with petitioners that there must be a loan repayment schedule or payment of interest in order for the Department to consider these payments to represent liabilities. The possibility of repayment was real. Therefore, the provisional capital increase is properly treated as a loan.

#### Comment 4

Petitioners argue that the scope of operations of the various entities that produce(d) electrical steel (*i.e.*, Terni, TAS, and the Specialty Steels Division of ILVA) has changed significantly over the years as a result of a series of restructurings. Petitioners argue that since TAS was created during the 1987 restructuring out of the assets of Terni, I.A.I. and Terminoss, Terni between 1978 and 1986 was not the same as the Specialty Steels Division of ILVA after 1989, which includes the assets of I.A.I. and Terminoss. According to petitioners, the Department must use a denominator which represents the ability to generate sales at the time a subsidy was given.

According to petitioners, the significant difference between 1986 sales of Terni and 1992 sales of ILVA's Specialty Steels Division indicates that these two entities are similar in name

only. Petitioners note that, in cases involving a merger, it is the Department's practice to perform a "tying analysis" in order to measure the benefits to the entity originally receiving the subsidy. Petitioners argue that since the 1987 restructuring of Terni cannot be separated from the overall Finsider restructuring, the Department, as it did in the preliminary determination of Certain Steel from Italy, should adjust ILVA's sales denominator in order to "reflect steel activities prior its restructuring." According to petitioners, the Department should use the sales of ILVA's Specialty Steels Divisions Terni plant (plus its share of intercompany sales) as the denominator for Terni-specific loans and grants, thereby excluding the stainless steel activities of ILVA's Specialty Steels Division.

Respondents argue that, since Terni's stainless steel producing subsidiaries (I.A.I. and Terminoss), and other Terni assets were merely merged into a new entity, TAS, which subsequently became the Specialty Steels Division of ILVA, the restructurings did not dramatically alter the entity producing the subject merchandise. As such, according to respondents, the Department should reject suggestions that stainless steel sales be subtracted from the denominator.

Respondents further argue that the difference between Terni sales in 1986 and ILVA's Specialty Steels Division sales in 1992 can be explained by increased activity in areas whose production capability was enhanced pursuant to restructuring. Moreover, respondents argue that a company's sales cannot be expected to remain "static" as petitioners suggest. Finally, respondents also argue that, according to the Department's "pass-through" methodology, the Department should find that the price paid by TAS for I.A.I. and Terminoss represented the exchange of one "subsidized" asset for another asset.

#### DOC Position

We disagree with petitioners that the 1987 restructuring was so fundamental that a comparison cannot be made between Terni and the Specialty Steels Division of ILVA. We believe that it is incorrect to characterize the merger of I.A.I. and Terminoss into TAS as the introduction of unrelated assets to the producer of the subject merchandise. Since I.A.I. and Terminoss were both subsidiaries of Terni prior to the 1987 restructuring, we find no reason to eliminate stainless steel sales from the Terni-specific denominator.

We do not disagree with petitioners that ILVA's sales have to be adjusted to

properly measure subsidies given to Terni/TAS. As noted by petitioners, in Certain Steel from Italy the Department adjusted ILVA sales to calculate subsidy margins for benefits accruing to Italsider and/or Nuova Italsider. To accomplish the same results in this investigation, we have used the sales of the Specialty Steels Division of ILVA to calculate the subsidy margin for Terni-specific benefits, rather than the sales of ILVA.

Finally, we agree with respondents that a company's sales cannot be expected to remain the same over time; *i.e.*, a comparison of nominal sales values separated by six years does not take into consideration inflation or the internal economies of scale resulting from restructuring.

#### Comment 5

Petitioners state that the Department did not use the highest interest rate on the record of the investigation for calculating the benchmark in its preliminary determination. Petitioners note that the IMF interest rates that it submitted in the petition are higher in some instances than the interest rate used by the Department.

The GOI, on the other hand, argues that petitioners' suggestion that the Department use the Italian "lending rate," as provided by the IMF, should be rejected since this is a short-term interest rate. Therefore, according to the GOI, this interest rate should not be considered representative of the highest long-term interest rate in Italy. Respondents state that the Department, as it did in the final determination of Certain Steel, correctly used the reference rate provided by the Bank of Italy to calculate benchmark rates.

#### DOC Comment

We note that the Bank of Italy's reference rate is the highest average long-term fixed interest rate on the record of this investigation. Because section 355.44(b)(6)(iv)(A) of the Proposed Regulations lists short-term interest rates as the least preferred choice for an uncreditworthy long-term interest rate benchmark, we cannot use the IMF "lending rate" as suggested by petitioners. Accordingly, the Department has continued to use the reference rate plus 12 percent of the ABI prime rate for purposes of constructing benchmark and discount rates.

#### Comment 6

Respondents argue that in cases involving companies experiencing a major restructuring or expansion, the Department recognizes that a reasonable private investor's analysis may depend on the company's prospects, rather than

its past financial experience. Respondents cite to Certain Carbon Steel Products from Sweden, 58 FR 37385 (July 9, 1993) in support of their argument.

According to respondents, the ECSC Treaty permits government investment in a state-owned steel company only in cases where the EC determines that such investment is provided "under circumstances acceptable to a private investor operating under normal market economy conditions." Because of this requirement, a team of independent experts examined the GOI's proposed restructuring plan and concluded that the implementation of the plan afforded ILVA reasonable chances of achieving financial viability under normal market conditions.

Respondents further argue that the Department has considered the EC's approval of government equity investments as evidence that the transaction confers no countervailable benefits. Respondents cite to the administrative review of Industrial Nitrocellulose from France, 52 FR 833 (January 9, 1987), which involved the French nitrocellulose industry.

Petitioners argue that ILVA's claim of equityworthiness in 1988 is without merit. ILVA's predecessor companies, including Terni, incurred losses in every year examined by the Department. In addition, petitioners argue that nothing on the record suggests that ILVA's prospects after 1988 were so optimistic as to overcome years of poor financial performance and justify commercial investment by a private investment company.

#### DOC Position

We agree with respondents that where a major restructuring or expansion occurs, it may be appropriate to place greater reliance on the future prospects of the company than would be the case where an equity investment is made in an established enterprise (see GIA at 37244). For example, in the Swedish Steel case cited by respondents, we considered such factors as: (1) The anticipated rate of return on equity; (2) the extended length of time before the company was projected to be profitable; (3) the prospects of the world steel industry; (4) the cost structure of the company.

In this instance, the 1988 equity investment was made in ILVA, a company which would differ from the operating companies that went into it principally because of the substantial debt forgiveness that occurred as part of the 1988-90 restructuring. Relieved of this debt, ILVA's balance sheet, when it began operations in 1989, would be

much improved over that of its predecessor, Finsider.

Beyond this, however, we have little indication of ILVA's future prospects. There is no information on expected rates of return, the time frame for achieving profitability, or developments in the steel market that would allow us to reach a conclusion that ILVA would yield a reasonable rate of return in a reasonable period of time.

Respondents have discussed two indicators of the future prospects of ILVA, the independent study undertaken by the EC and the EC's decision allowing the investment. With respect to the study, it was not placed on the record and we have had no opportunity to analyze it. Without such analysis, we cannot simply accept respondents' characterization of the study's conclusion.

We also disagree with respondents that the EC's finding on this investment is dispositive. Our determinations of equityworthiness are made in accordance with the Department's standards, not the EC's. In Final Affirmative Countervailing Duty Determination: Certain Hot Rolled Lead and Bismuth Carbon Steel Products from France, 58 FR 6221, 6232 (January 27, 1993), we explicitly rejected the EC approval of the investment as not relevant. In Industrial Nitrocellulose from France, cited by respondents, the Department performed its own analysis and, contrary to respondents' assertion, did not rely on an EC finding. Respondents' reliance on "principles of comity" (citing the Restatement (Third) of Foreign Relations Law of the United States (ALI) section 481, is also inapposite, because comity involves respecting foreign judgments regarding the disposition of property and the status of persons.

Finally, while indicators of past performance may be less important, we do not believe that a private investor would ignore them entirely. As explained in our discussion of Terni's equityworthiness above, that company had performed poorly. Similarly, Italsider, another company that was restructured into ILVA, had performed poorly (see Certain Steel from Italy). Therefore, the past performance of companies that became ILVA offered no basis to believe that the 1988 investment in ILVA was consistent with commercial considerations.

#### Comment 7

Respondents argue that the Department only countervails worker assistance when a company is relieved of an obligation it would otherwise incur. According to respondents,

because it confirmed at verification that Italian companies have no obligation to retrain their workers, the Department should conclude that ECSC Article 56 worker training is not countervailable.

#### DOC Position

First, it should be noted that we did not countervail the portion of Article 56 retraining grants funded by the ECSC. With respect to the portion funded by the GOI under Law 181/89, we disagree that the workers assistance provision of the Proposed Regulations is applicable in this situation. There is a distinction between funds which cover the cost of upgrading the skills of workers remaining at ILVA (which is a cost normally born by the company to improve the efficiency of its work force), and funds provided to train workers leaving ILVA, which we consider a benefit solely to the worker. Only the former is properly categorized as countervailable "worker assistance" under section 355.44(j) of the Proposed Regulations, to the extent that it relieves the company of the cost of improving its workers' skills.

Since the GOI's contributions to match the ECSC Article 56 payments were only available to steel companies and these funds were used to cover part of ILVA's costs of training workers who remained at ILVA, we find that a countervailable benefit is being provided.

#### Comment 8

The GOI states that, based on the clearer understanding gained by the Department at verification regarding the types of loans eligible for Law 796/76 exchange rate guarantees, this program should be found not countervailable.

#### DOC Position

We note that the Department failed to send the GOI a deficiency questionnaire indicating that more information was needed to demonstrate the *de facto* use of Law 796/76. When it became evident at verification that such information was needed, we attempted to gather it. However, the information could not be provided in the form necessary in the limited time available during verification.

Accordingly, we have not made the adverse inference that this program is *de facto* specific to the steel industry. However, we note that this finding of non-countervailability only relates to this investigation and is subject to revision at the first administrative review if a countervailing duty order is issued.

#### Comment 9

The GOI notes that exports of the subject merchandise to the U.S. were not financed using Law 227/77. According to the GOI, this financing should not be considered countervailable because it is not limited to a particular industry and is also consistent with the Organization for Economic Cooperation and Development Understanding on official export credits. The GOI argues that since this financing is permitted by a multilateral agreement binding both the U.S. and Italy, it should not be considered countervailable.

#### DOC Position

We found no countervailable benefits under this program because ILVA did not use this financing for exports to the United States. With respect to the other arguments raised by the GOI, since this program provided export financing, its availability to a large number of industries is not relevant. For export subsidies, we need only find, pursuant to 355.43(a)(1) of the Proposed Regulations, that the financing for exports is provided at preferential rates. Second, although the U.S. and Italy participate in the OECD arrangement which establishes the interest rates that can be charged on export loans, nothing in that arrangement would preclude the application of countervailing duties on merchandise entering the U.S. which received subsidized financing.

#### Comment 10

Respondents note that at verification, the Department determined that Law 181/89 actually had three components: (1) the creation of alternative employment opportunities; (2) the development of new industrial initiatives ("reindustrialization"); and (3) worker retraining. Respondents state that the Department further determined that ILVA only received funds under the reindustrialization provision of Law 181/89.

Of the three reindustrialization projects, respondents claim that two were tied to non-subject merchandise. Therefore, they are not countervailable pursuant to section 355.47 of the Proposed Regulations. The third reindustrialization project was a "retraining center." Respondents argue that the Proposed Regulations state that "worker assistance" is only countervailable to the extent that it relieves a company of an obligation that it would otherwise incur (see section 355.44(j) of the Proposed Regulations). Since there is no obligation in Italy to



retrain workers, this project does not provide a countervailable benefit.

#### *DOC Position*

As a matter of clarification, we found that Law 181/89 has four components, the fourth being early retirement. However, the early retirement component expired prior to the POI. Since early retirement is typically considered a recurring benefit and, therefore, allocable to the year in which received, we did not establish the extent to which it had or had not been used by ILVA.

Regarding the reindustrialization component, we agree that two of the projects involved the further processing of non-subject merchandise. Therefore, we have found them not countervailable.

However, with respect to the training center, we disagree that this amounted to worker assistance within the meaning of the Proposed Regulations. As discussed in Comment 7 above, there is a distinction between worker assistance and funds that are being used to cover the costs that ILVA would incur to train its work force. Although not exclusively, the training center in question is used to upgrade the technical skills of ILVA workers. Therefore, we have determined that the GOI payments to cover part of the cost of building a training center provide a countervailable benefit to ILVA.

#### *Comment 11*

The GOI argues that the early retirement program would only be countervailable if companies had no choice but to keep surplus workers on the payroll. However, companies can carry out large-scale lay-offs under Italian law. Thus, the GOI contends that early retirement is an alternative to lay-offs and not an alternative to maintaining excess workers. The GOI contends that because companies are required to contribute to the costs for early retirement, the program is a burden, not a benefit, to them. The only beneficiaries under the early retirement program are the workers.

Moreover, according to respondents, early retirement is available to workers in a broad range of industries. The Department should, therefore, find that there is no selective treatment under the program.

According to petitioners, verification confirmed that early retirement is only available to a limited group of industries. Moreover, because use of early retirement under Article 27 is contingent upon approval from a government committee, the GOI exercises discretion in determining

which industries can use the program. Petitioners also argue that Italian companies have an obligation to provide early retirement benefits once the workers have opted for the program. The benefit should, therefore, be calculated as the GOI's contribution to the program because if government funds had not been provided, ILVA would have been legally responsible for the entire cost, according to petitioners.

#### *DOC Position*

We agree with the GOI that, by law, companies in Italy can carry out large-scale lay-offs. Moreover, we have no evidence that Italian companies have a legal obligation to keep workers on the payroll until they reach normal retirement age. However, based on verification, we have found that some companies, including ILVA, belong to a category of firms that must go through certain "steps and procedures," in the form of the provisions under Law 223/91 before they actually can reduce the workforce. In practice, therefore, large companies are obligated to use Law 223/91 to deal with surplus workers.

Regarding the general availability of early retirement, the structure of Law 223/91 is such that the early retirement option is available to a smaller group of companies than the lay-off option, CIG-S. Because the GOI was not able to provide evidence showing that the steel producers did not receive a disproportionate share of the quota granted under the early retirement option, we have used CIG-S as our "benchmark." Since the financial obligations imposed on the company under early retirement are more onerous than the obligations under CIG-S, we have determined that ILVA did not receive a benefit under the early retirement program.

#### *Comment 12*

Petitioners argue that the shares in ILVA owned by Italsider (in liquidation) were transferred to TAS free-of-charge in 1990. Respondents argue that ILVA did provide an invoice from Italsider requesting payment from TAS but that ILVA was unable to locate the payment record during verification. Moreover, respondents argue that the Department never posed the question of payment to TAS (in liquidation), nor did the Department verify the records of TAS (in liquidation). Therefore, respondents argue, ILVA should not be penalized for any missing information over which it has no control.

#### *DOC Position*

As discussed above in connection with the 1988-90 restructuring,

petitioners alleged several subsidies to TAS after the second asset transfer and receipt of Italsider's shares by TAS was among them. As we explained, we believe that we have captured the full benefit to the subject merchandise from the restructuring without analyzing these individual transactions. Therefore, TAS' payment or non-payment to Italsider is irrelevant to our analysis.

However, although we did not verify that TAS (in liquidation) paid Italsider for the shares, we do not believe that TAS kept the proceeds from the sale. This is because the proceeds were so large (1,563 billion lire) that they would have been more than enough to pay off all of TAS' outstanding liabilities and to return the company to a positive equity position. However, as TAS' books indicate, this did not happen.

#### *Comment 13*

Petitioners maintain that although evidence presented at verification may demonstrate that Terni received Law 750/81 funds based on its identity as a producer of forgings and castings, the Department nevertheless found that Terni's accounting records did not reflect that these grants were designated only for the production of forgings and castings. Therefore, petitioners argue that Terni treated and accounted for these grants as general funds, and did not specifically allocate them to its forgings and castings operations.

#### *DOC Position*

We find these grants to be not countervailable since they applied to merchandise not subject to this investigation. We disagree with petitioners' argument that Terni's treatment of these funds as "general funds" demonstrates that they were not specifically allocated to the production of forgings and castings. We stated in the *GIA* that when a company receives a general subsidy, the Department does not attempt to "trace" or establish how the subsidy was used. Conversely, if the subsidy is tied to the production of merchandise other than the merchandise under investigation, the Department also does not attempt to trace or establish how the subsidy was ultimately used. Furthermore, we believe that respondents provided sufficient documentation, which is fully discussed in the ILVA verification report, that grants under this program specifically applied to the production of forgings and castings. As stated in the *GIA* at 37267, if the benefit is tied to a product other than the merchandise under investigation, the Department will not find a countervailable subsidy on the subject merchandise.

### Verification

In accordance with section 776(b) of the Act, we verified the information used in making our final determination. We followed standard verification procedures, including meeting with government and company officials, examination of relevant accounting records and examination of original source documents. Our verification results are outlined in detail in the public versions of the verification reports, which are on file in the Central Records Unit (room B-099 of the Main Commerce Building).

### Suspension of Liquidation

In accordance with our affirmative preliminary determination, we instructed the U.S. Customs Service to suspend liquidation of all entries of electrical steel from Italy, which were entered or withdrawn from warehouse for consumption, on or after February 1, 1994, the date our preliminary determination was published in the *Federal Register*. If the ITC issues a final affirmative injury determination, we will instruct Customs to require a cash deposit for entries of the merchandise after that date in the amounts indicated below.

	Percent
Electrical Steel Country-Wide Ad Valorem Rate .....	24.42

### ITC Notification

In accordance with section 705(d) of the Act, we will notify the ITC of our determination. In addition, we are making available to the ITC all nonprivileged and nonproprietary information relating to this investigation. We will allow the ITC access to all privileged and business proprietary information in our files, provided the ITC confirms that it will not disclose such information, either publicly or under an administrative protective order, without the written consent of the Deputy Assistant Secretary for Investigations, Import Administration.

If the ITC determines that material injury, or threat of material injury, does not exist, these proceedings will be terminated and all estimated duties deposited or securities posted as a result of the suspension of liquidation will be refunded or cancelled. If, however, the ITC determines that such injury does exist, we will issue a countervailing duty order directing Customs officers to assess countervailing duties on electrical steel from Italy.

### Return of Destruction of Proprietary Information

This notice serves as the only reminder to parties subject to Administrative Protective Order (APO) of their responsibility concerning the return or destruction of proprietary information disclosed under APO in accordance with 19 CFR 355.34(d). Failure to comply is a violation of the APO.

This determination is published pursuant to section 705(d) of the Act and 19 CFR 355.20(a)(4).

Dated: April 11, 1994.

Susan G. Esserman,

Assistant Secretary for Import Administration.

[FR Doc. 94-9313 Filed 04-15-94; 8:45 am]

BILLING CODE 3510-05-P

### California Institute of Technology; Notice of Decision on Application for Duty-Free Entry of Scientific Instrument

This decision is made pursuant to Section 6(c) of the Educational, Scientific, and Cultural Materials Importation Act of 1966 (Pub. L. 89-651, 80 Stat. 897; 15 CFR 301). Related records can be viewed between 8:30 A.M. and 5:00 P.M. in Room 4211, U.S. Department of Commerce, 14th and Constitution Avenue, N.W., Washington, D.C.

**Comments:** None received. **Decision:** Approved. No instrument of equivalent scientific value to the foreign instrument, for such purposes as it is intended to be used, is being manufactured in the United States.

**Docket Number:** 94-006. **Applicant:** California Institute of Technology, Pasadena, CA 91125. **Instrument:** Mass Spectrometer, Model 215-50. **Manufacturer:** Mass Analyser Products, Ltd., United Kingdom. **Intended Use:** See notice at 59 FR 6621, February 11, 1994. **Reasons:** The foreign instrument provides (1) an abundance sensitivity of less than 1 ppm of <sup>40</sup>Ar detected at <sup>39</sup>Ar with an analyzer pressure of 10<sup>-7</sup> torr and (2) a background for M/e 36 less than 5x10<sup>-14</sup> cm<sup>3</sup> STP and M/e 132 less than 10<sup>-15</sup> cm<sup>3</sup> STP.

This capability is pertinent to the applicant's intended purposes and we know of no other instrument or apparatus of equivalent scientific value to the foreign instrument which is being manufactured in the United States.

Pamela Woods

Acting Director, Statutory Import Programs Staff

[FR Doc. 94-9304 Filed 4-15-94; 8:45 am]

BILLING CODE 3510-05-F

### Applications for Duty-Free Entry of Scientific Instruments

Pursuant to Section 6(c) of the Educational, Scientific and Cultural Materials Importation Act of 1966 (Pub. L. 89-651; 80 Stat. 897; 15 CFR 301), we invite comments on the question of whether instruments of equivalent scientific value, for the purposes for which the instruments shown below are intended to be used, are being manufactured in the United States.

Comments must comply with Subsections 301.5(a)(3) and (4) of the regulations and be filed within 20 days with the Statutory Import Programs Staff, U.S. Department of Commerce, Washington, D.C. 20230. Applications may be examined between 8:30 A.M. and 5:00 P.M. in Room 4211, U.S. Department of Commerce, 14th Street and Constitution Avenue, N.W., Washington, D.C.

**Docket Number:** 94-009. **Applicant:** LSU and A&M College, c/o IRM, 1419 CEBA Bldg., Baton Rouge, LA 70803.

**Instrument:** Pavement Materials Testing Apparatus. **Manufacturer:** Industrial Process Controls Ltd., Australia.

**Intended Use:** The instrument will be used to study the behavior of soil, rock, industrial by-products and recycled construction materials under repeated loading. In addition, the instrument will be used in post graduate level civil engineering courses in the Transportation Program to educate a new generation of transportation professionals to design, build and maintain vital facilities into the 21st century. **Application Accepted by Commissioner of Customs:** March 24, 1994.

**Docket Number:** 94-037. **Applicant:** University of Delaware, College of Marine Studies, Robinson Hall, Room 114, Newark, DE 19716. **Instrument:** Used Mass Spectrometer, Model VG Prism Series II. **Manufacturer:** VG Isogas/Fisons Instruments, United Kingdom. **Intended Use:** The instrument will be used extensively for the analysis of the stable oxygen and carbon isotopic composition (<sup>18</sup>O/<sup>16</sup>O and <sup>13</sup>C/<sup>12</sup>C, respectively) of biogenic carbonates such as clam and scallop shells, foraminifera, and ostracodes to obtain data which will allow detailed interpretations of environmental conditions (temperature, salinity, carbon cycling) in the geologic past. Other uses include research on the physiological response of plants to water stress (i.e. drought conditions) and controlled experiments in a growth chamber fitted with a gas-permeable membrane to quantify the response of marine phytoplankton to variable

nutrient and light conditions. In addition the instrument will be used for educational purposes in the course Stable Isotope Geochemistry (MAST 667). *Application Accepted by Commissioner of Customs:* March 29, 1994.

*Docket Number:* 94-039. *Applicant:* VA Medical Center (Atlanta), 1670 Clairmont Road, Decatur, GA 30033. *Instrument:* Electron Microscope, Model JEM 1210. *Manufacturer:* JEOL Ltd., Japan. *Intended Use:* The instrument will be used to generate and support research projects underway in the Research Service of the medical center. A variety of specimens including animal tissue samples, cell cultures and other materials will be studied. In addition, the instrument will be important in the training of medical and graduate students, resident physicians and fellows and staff. *Application Accepted by Commissioner of Customs:* March 24, 1994.

*Docket Number:* 94-040. *Applicant:* University of Wisconsin-Madison, Integrated Microscopy Resource, 1525 Linden Drive, Madison, WI 53706. *Instrument:* Laser System. *Manufacturer:* Microlase Optical Systems Ltd., United Kingdom. *Intended Use:* The instrument will be used as a fluorescence excitation source for the study of the dynamics of the internal cellular architecture of living biological specimens in order to understand how the internal machinery of a cell functions during development. In addition, the instrument will be used in courses on advanced microscopy techniques for undergraduates, graduate students and visiting academic research workers. *Application Accepted by Commissioner of Customs:* March 25, 1994.

*Docket Number:* 94-041. *Applicant:* The University of Michigan, 1150 W. Medical Center Drive, Ann Arbor, MI 48109-0626. *Instrument:* Rapid Kinetic Spectrofluorimeter, Model SX.17MV. *Manufacturer:* Applied Photophysics Ltd., United Kingdom. *Intended Use:* The instrument will be used for fluorescence studies of biological molecules present at low concentrations (nM). Experiments will be conducted to identify the mechanism of nucleotide binding to and activation of G proteins. *Application Accepted by Commissioner of Customs:* March 28, 1994.

*Docket Number:* 94-042. *Applicant:* U.S. Environmental Protection Agency, Office of Research & Development, P.O. Box 93478, Las Vegas, NV 89193-3478. *Instrument:* ICP Mass Spectrometer, Model VG PlasmaQuad. *Manufacturer:* Fisons Instruments, United Kingdom. *Intended Use:* The instrument will be

used for studies of synthetic and natural environmental samples (water, soils, plant materials, etc.). The materials, or extracts of the materials, will be injected into a liquid chromatograph that will be interfaced with the instrument. The extremely high sensitivity of the instrument should allow the detection of very small concentrations of individual chemical forms of trace metals. *Application Accepted by Commissioner of Customs:* March 31, 1994.

**Pamela Woods**

*Acting Director, Statutory Import Programs Staff*

[FR Doc. 94-9305 Filed 4-15-94; 8:45 am]

BILLING CODE 3510-DS-F

**National Oceanic and Atmospheric Administration**

[I.D. 041194B]

**Gulf of Mexico Fishery Management Council; Meeting**

**AGENCY:** National Marine Fisheries Service (NMFS), National Oceanic and Atmospheric Administration (NOAA), Commerce.

**ACTION:** Notice of public meeting.

**SUMMARY:** The Gulf of Mexico Fishery Management Council's Mackerel Advisory Panel (AP) and Reef Fish, Mackerel, Spiny Lobster, and Stone Crab Scientific and Statistical Committees (SSC) will hold public meetings on May 2-4, 1994, to review, and advise the Council on, amendments to Federal rules affecting mackerel, reef fish, stone crab and spiny lobster.

The meetings will be held at the Radisson Inn, New Orleans Airport, 2150 Veterans Memorial Boulevard, Kenner, LA; telephone: (504) 467-3111.

On May 2, beginning at 2:30 p.m., the SSC will develop recommendations on an amendment that proposes to allow certain fishermen landing reef fish with traps, or investing in traps prior to February 7, 1994, to be granted permits to use fish traps during the current 3-year moratorium on issuance of such permits.

On May 3, beginning at 8 a.m., the SSC will review and make recommendations on an amendment to the stone crab regulations which proposes a 4-year moratorium on issuance of commercial vessel registrations to participate in the fishery and a procedure for implementing state rules in the Federal waters. The SSC will also develop recommendations on a generic amendment that contains proposals for defining traps used in the reef fish, spiny lobster, stone crab and

other fisheries, as well as areal and seasonal limitations on trap use. Beginning at noon, the SSC will review the mackerel and cobia information and formulate its recommendations to the Council.

The Mackerel AP will meet on May 4 beginning at 10 a.m., to review stock assessment and social and economic information on king mackerel, Spanish mackerel, and cobia (ling). Based on this review, it will recommend to the Council levels for setting total allowable catch (TAC), commercial vessel trip limits, bag limits, and commercial quotas for these species for the 1994-95 season.

**FOR FURTHER INFORMATION CONTACT:**

(Mackerel) Terrance R. Leary, Fishery Biologist, (Reef Fish) Steven M. Atran, Population Dynamics Statistician, or (Stone Crab and Spiny Lobster) Wayne E. Swingle, Executive Director, Gulf of Mexico Fishery Management Council, 5401 West Kennedy Boulevard, Suite 331, Tampa, FL; telephone: (813) 228-2815.

**SUPPLEMENTARY INFORMATION:** The meeting is physically accessible to people with disabilities. Requests for sign language interpretation or other auxiliary aids should be directed to the above address by April 25, 1994.

Dated: April 12, 1994.

**David S. Crestin,**

*Acting Director, Office of Fisheries Conservation and Management, National Marine Fisheries Service.*

[FR Doc. 94-9198 Filed 4-15-94; 8:45 am]

BILLING CODE 3510-22-P

[I.D. 040894E]

**Mid-Atlantic Fishery Management Council; Meeting**

**AGENCY:** National Marine Fisheries Service (NMFS), National Oceanic and Atmospheric Administration (NOAA), Commerce.

**ACTION:** Notice of public meeting.

**SUMMARY:** The Mid-Atlantic Fishery Management Council's Squid, Mackerel, and Butterfish Committee and its Squid, Mackerel, and Butterfish Industry Advisory Subcommittee will meet on May 9, 1994, at the Ramada Inn (1776 Room), 76 Industrial Highway, Essington, PA. The meeting will begin at 10:00 a.m.

The following topics will be discussed:

- (1) Problems to be addressed in Amendment 5; and
- (2) Alternative management strategies.

**FOR FURTHER INFORMATION CONTACT:**

David R. Keifer, Executive Director, Mid-

Atlantic Fishery Management Council,  
300 S. New Street, Dover, DE 19901;  
telephone: (302) 674092331.

**SUPPLEMENTARY INFORMATION:** This meeting is physically accessible to people with disabilities. Requests for sign language interpretation or other auxiliary aids should be directed to Joanna Davis at (302) 674092331 at least 5 days prior to the meeting date.

Dated: April 11, 1994

**David S. Crestin,**

*Acting Director, Office of Fisheries Conservation and Management, National Marine Fisheries Service.*

[FR Doc. 94-9199 Filed 4-15-94; 8:45a.m.]

**BILLING CODE 3510-22-F**

### Monterey Bay National Marine Sanctuary Advisory Council; Meeting

**AGENCY:** Sanctuaries and Reserves Division (SDR), Office of Ocean and Coastal Resource Management (OCRM), National Ocean Service (NOS), National Oceanic and Atmospheric Administration (NOAA), Department of Commerce.

**ACTION:** Monterey Bay National Marine Sanctuary Advisory Council open meeting.

**SUMMARY:** The Advisory Council was established in December 1993 to advise and assist the Secretary of Commerce in the implementation of the management plan for the Monterey Bay National Marine Sanctuary.

**TIME AND PLACE:** April 29, 1994 from 9 until 3:30. The meeting location will be at the Monterey Conference Center, Serra Ballroom Number One, Monterey, California.

**AGENDA:** General issues related to the Monterey Bay National Marine Sanctuary are expected to be discussed.

**PUBLIC PARTICIPATION:** The meeting will be open to the public.

Seats will be available on a first-come, first-served basis.

**FOR FURTHER INFORMATION CONTACT:** Aaron King at (408) 647-4257 or Elizabeth Moore at (301) 713-3141.

Federal Domestic Assistance Catalog Number 11.429 Marine Sanctuary Program.

Dated: April 13, 1994.

**W. Stanley Wilson,**

*Assistant Administrator for Ocean Services and Coastal Zone Management.*

[FR Doc. 94-9299 Filed 4-15-94; 8:45 am]

**BILLING CODE 3510-08-M**

### COMMITTEE FOR THE IMPLEMENTATION OF TEXTILE AGREEMENTS

#### Amendment of Export Visa Requirements for Certain Cotton and Man-Made Fiber Textile Products Produced or Manufactured in the Philippines; Correction

April 12, 1994.

In a notice published in the *Federal Register* on March 24, 1994 (59 FR 13933), make the following changes:

1. Column 2, under "Supplementary Information," replace paragraph 2 with the following: The existing visa arrangement between the Governments of the United States and the Philippines is being amended to eliminate part-category designations 340-Y, 340-O, 640-Y, 640-O, 340-Y/640-Y and 340-O/640-O for goods produced or manufactured in the Philippines and exported from the Philippines on and after January 26, 1994. For the period January 26, 1994 through April 30, 1994, merchandise in Categories 340 and 640 may be visaed either as 340, 340-Y, 340-O, 340/640, 340-Y/640-Y, 340-O/640-O, 640, 640-Y or 640-O. Goods exported on or after May 1, 1994 must be visaed as Category 340 or 640 or merged Categories 340/640.

2. Column 3, in the letter to the Commissioner of Customs, replace paragraphs 2, 3 and 4 with the following: Effective on March 23, 1994, you are directed to amend further the April 3, 1987 directive to eliminate part-category designations 340-Y, 340-O, 640-Y, 640-O, 340-Y/640-Y and 340-O/640-O for goods produced or manufactured in the Philippines and exported from the Philippines on and after January 26, 1994. For the period January 26, 1994 through April 30, 1994, merchandise in Categories 340 and 640 may be visaed either as 340, 340-Y, 340-O, 340/640, 340-Y/640-Y, 340-O/640-O, 640, 640-Y or 640-O. Goods exported on and after May 1, 1994 must be visaed as Category 340 or 640 or merged Categories 340/640.

**Rita D. Hayes,**

*Chairman, Committee for the Implementation of Textile Agreements.*

[FR Doc. 94-9302 Filed 4-15-94; 8:45 am]

**BILLING CODE 3510-DR-F**

### DEPARTMENT OF DEFENSE

#### Department of the Army

#### Army Science Board; Notice of Closed Meeting

In accordance with section 10(a)(2) of the Federal Advisory Committee Act

(Pub. L. 92-463), announcement is made of the following Committee Meeting:

*Name of Committee:* Army Science Board (ASB).

*Date of Meeting:* 3-4 May 1994.

*Time of Meeting:* 0800-1700 and 0800-1500, respectively.

*Place:* The Pentagon, Washington, DC.

*Agenda:* The Army Science Board's Summer Study Panel on "Capabilities Required to Counter Current & Evolving Threats" will meet to hear briefings on and discuss advanced and novel technology forecasts, operational enhancements and future force structure/doctrinal implications. This meeting will be closed to the public in accordance with Section 552(b)(c) of Title 5, U.S.C., specifically subparagraph (1) thereof, and Title 5, U.S.C., Appendix 2, subsection 10(d). The classified and unclassified matters to be discussed are so inextricably intertwined so as to preclude opening all portions of the meeting. The ASB Administrative Officer Sally Warner, may be contacted for further information at (703) 695-0781.

**Herbert J. Gallagher,**

*COL, GS, Executive Secretary.*

[FR Doc. 94-9272 Filed 4-15-94; 8:45 am]

**BILLING CODE 3710-08-M**

#### Army Science Board; Notice of Open Meeting

In accordance with section 10(a)(2) of the Federal Advisory Committee Act (Pub. L. 92-463), announcement is made of the following Committee Meeting:

*Name of Committee:* Army Science Board (ASB)

*Date of Meeting:* 4, 5 & 6 May 1994.

*Time of Meeting:* 0800-1700.

*Place:* TRADOC, Ft. Monroe.

*Agenda:* The Army Science Board's Summer Study Panel on "Technical Architecture for C4I" will meet to hear briefings from the user community on C4I program, systems, & architecture. This meeting will be open to the public. Any interested person may attend, appear before, or file statements with the committee at the time and in the manner permitted by the committee. The ASB Administrative Officer, Sally Warner, may be contacted for further information at (703) 695-0781.

**Herbert J. Gallagher,**

*COL, GS, Executive Secretary.*

[FR Doc. 94-9273 Filed 4-15-94; 8:45 am]

**BILLING CODE 3710-08-M**

#### Army Science Board; Notice of Closed Meeting

In accordance with section 10(a)(2) of the Federal Advisory Committee Act (Pub. L. 92-463), announcement is made of the following Committee Meeting:

*Name of Committee:* Army Science Board (ASB).

*Date of Meeting:* 10 May 1994.

*Time of Meeting:* 0800-1700.

*Place:* Fort Sill, Oklahoma.

*Agenda:* The Army Science Board's Ad Hoc Study on "Innovations in Artillery Force Structure" will hold a meeting of the Panel Members. This meeting will be hosted by the Commanding General and Director of Combat Developments, U.S. Army Field Artillery Center, Fort Sill, Oklahoma. The intent of the meeting is to conduct a review of progress in the study following the fact finding phase. Discussions will be mostly in a round table format with topics relating to force structure development within the US Army Field Artillery. This meeting will be closed to the public in accordance with section 552b(c) of Title 5, U.S.C., specifically subparagraph (1) thereof, and Title 5, U.S.C., appendix 2, subsection 10(f). The classified and unclassified matters to be discussed are so inextricably intertwined so as to preclude opening all portions of the meeting. The ASB Administrative Officer Sally Warner, may be contacted for further information at (703) 695-0781.

Herbert J. Gallagher,

COL, GS, Executive Secretary.

[FR Doc. 94-9274 Filed 4-15-94; 8:45 am]

BILLING CODE 3710-08-M

### Army Science Board; Notice of Closed Meeting

In accordance with section 10(a)(2) of the Federal Advisory Committee Act (Pub.L. 92-463), announcement is made of the following Committee Meeting:

*Name of Committee:* Army Science Board (ASB).

*Date of Meeting:* 11 May 1994.

*Time of Meeting:* 0800-1730.

*Place:* The Pentagon, Washington, DC.

*Agenda:* The Army Science Board's Summer Study Panel on "Capabilities Required to Counter Current & Evolving Threats" will meet to hear briefings on and discuss advanced and novel technology forecasts, operational enhancements and future force structure/doctrinal implications. This meeting will be closed to the public in accordance with Section 552b(c) of Title 5, U.S.C., specifically subparagraph (1) thereof, and Title 5, U.S.C., appendix 2, subsection 10(d). The classified and unclassified matters to be discussed are so inextricably intertwined so as to preclude opening all portions of the meeting. The ASB Administrative Officer Sally Warner, may be contacted for further information at (703) 695-0781.

Herbert J. Gallagher,

COL, GS, Executive Secretary.

[FR Doc. 94-9275 Filed 4-15-94; 8:45 am]

BILLING CODE 3710-08-M

### Corps of Engineers

#### Intent To Prepare a Draft Environmental Impact Statement (DEIS) for a Municipal Solid-Waste Landfill Proposed by Resource Investments, Inc. in Pierce County, WA

**AGENCY:** U.S. Army Corps of Engineers, Seattle District, DOD.

**ACTION:** Notice of intent.

**SUMMARY:** Resource Investments, Inc. (RII) of Puyallup, Washington is proposing construction and operation of a private solid-waste landfill on a 320-acre site in central Pierce County, Washington. The project site is located at the intersection of State Route (SR) 161 (Meridian) and 304th Street East (Kapowsin Highway), approximately 15 miles south of Puyallup, Washington. Construction of the landfill's cells and support facilities will impact approximately 33 acres of wetlands, including palustrine emergent, scrub-shrub, and forested wetlands. The proposed project may also require relocating 2,600 linear feet of the South Fork of Muck Creek (South Creek) which flows through the northwest corner of the site. South Creek is a seasonal tributary to Much Creek, which is a tributary of the Nisqually River. The proposed site is located over the Clovers-Chambers Creek Sole Source Aquifer which has been designated by the Environmental Protection Agency as a "Sole Source Aquifer." Work in wetlands and South Creek will require a Department of the Army Permit under section 404 of the Clean Water Act. **FOR FURTHER INFORMATION CONTACT:** Questions about the proposed action and DEIS can be answered by: Dr. Stephen Martin, Planning Branch, Environmental Resources Section, Seattle District, U.S. Army Corps of Engineers, Seattle, Washington 98124-2255, telephone (206) 764-3631.

#### SUPPLEMENTARY INFORMATION:

##### Proposed Action

RII has proposed the facility because the existing landfill in Pierce County (Hidden Valley, owned and operated by an affiliated company, Land Recovery, Incorporated) has nearly reached maximum capacity and is scheduled for closure sometime between January and September 1996. To extend the life of the existing Hidden Valley Landfill, Pierce County has opted to use this existing facility for approximately 80 percent of Pierce County's solid-waste disposal needs. The remaining 20 percent is long-hauled to the Rabanco Landfill (located in eastern Washington) via truck and rail.

The proposed project site is located in central Pierce County, approximately 15 miles south of Puyallup, Washington and approximately 12 miles north of Eatonville, Washington, adjacent to SR 161. The site is bounded by SR 161 (Meridian) to the west and 304th Street East (Kapowsin Highway) to the north. The landfill facility will occupy up to 177 acres of the relatively level 320-acre site. Fill in wetlands and in South Creek is necessary under the proposed action to construct the landfill's cells and support facilities.

The landfill design includes a bottom liner, temporary and permanent cover cap systems, a leachate collection system, a leak detection and collection system, a gas collection and combustion system, and a storm drainage system. The landfill would be constructed in a series of seven cells (one cell constructed and filled at a time) over approximately 20 years. The life of the proposed project would depend upon the waste stream volume and any fluctuations (i.e., increases or decreases from established 20-year projections).

RII's project purpose is to provide the unincorporated areas and the incorporated cities in Pierce County that participated in the 1989 Tacoma-Pierce County Solid Waste Management Plan and specifically not the military bases located within Pierce County with a viable, affordable, environmentally sound solid waste project to meet projected needs for the next 20 years.

#### Alternatives

a. The Corps of Engineers has three alternative courses of action available: (1) The section 404 permit could be issued with standard conditions for the proposed action as described above.

(2) The section 404 permit could be issued with standard and special conditions that would mitigate impacts resulting from the proposed action.

(3) The section 404 permit could be denied. This option would prohibit all proposed work impacting the wetlands and the stream on the project site as well as prevent environmental impacts associated with the proposed action in these areas. The economic and social benefits of the project to Pierce County residents would also be foregone.

b. Alternatives to be examined in the EIS include:

- (1) No action.
- (2) Off-site alternatives.
- (3) On-site alternatives.

#### Scoping and Public Involvement

An EIS was prepared under the Washington State Environmental Policy Act (SEPA) regarding this proposal. A public scoping meeting and public

hearings were held by Pierce County during development of the Draft SEPA EIS. After receiving extensive comments on the Draft, Pierce County issued a Final SEPA EIS in November 1990. In addition, over 200 comments have been submitted to the Corps of Engineers in response to the Corps' public notice for the permit application. Public involvement will be sought during scoping and conduct of the EIS in accordance with National Environmental Policy Act (NEPA) procedures. This Notice of Intent formally commences the scoping process under NEPA. As part of the scoping process, all affected Federal, State and local agencies, Indian Tribes, and other interested private organizations and citizens, including environmental groups, are invited to comment on issues of major concern and to identify any additional studies that might be needed in order to analyze and evaluate impacts. Comments are requested concerning project alternatives, probable significant environmental impacts, mitigation measures, and permits or other approvals that may be required. The following key areas have been identified to be analyzed in depth in the draft EIS:

1. Alternative Sites
2. Project Design
3. Potential for Surface and Groundwater Contamination
4. Wetlands
5. Water Quality
6. Amphibians and Reptiles
7. Waterfowl and Fisheries
8. Cultural Resources
9. Aesthetics
10. Transportation/Traffic
11. Social and Economic Characteristics
12. Cumulative Impacts
13. Endangered Species
14. Air Quality
15. Noise
16. Land Use/Zoning
17. Human Health and Safety
18. Earth/Geologic Resources
19. Wildlife and Plants

#### Scoping Meeting

Because over 200 comments have been submitted in response to a Corps of Engineer's public notice for the permit application covering a wide variety of issues, a formal scoping meeting pursuant to NEPA is not planned at this time. To assist the Corps in developing the scope of the EIS and in identifying important issues, comments are invited to be submitted in writing and should be forwarded to Seattle District, Corps of Engineers, before 15 May 1994. Previous comments provided to the Corps of Engineers on this project are on file and will be addressed in the NEPA EIS.

#### Other Environmental Review, Coordination, and Permit Requirements

Other environmental review, coordination, and permit requirements include preparation of a section 404(b)(1) evaluation by the Corps of Engineers; consultation among the Corps, the U.S. Fish and Wildlife Service, and the State of Washington per section 7 of the Endangered Species Act; acquisition by the applicant of a Conditional Use Permit and a Solid Waste Handling Permit from Pierce County, a Water Quality Certification and Hydraulics Project Approval from Washington State, and State concurrence with consistency pursuant to the Washington State Coastal Zone Management Program.

#### Availability of Draft EIS

The draft EIS is scheduled for release in December 1994.

Dated: March 30, 1994.

**ReX N. Osborne,**

*Lt. Colonel, Corps of Engineers, District Engineer.*

[FR Doc. 94-9058 Filed 4-15-94; 8:45 am]

BILLING CODE 3710-ER-M

#### Corps of Engineers

##### Coastal Engineering Research Board (CERB)

**AGENCY:** Coastal Engineering Research Board, U.S. Army Engineer Waterways Experiment Station, DOD.

**ACTION:** Notice.

In accordance with section 10(a)(2) of the Federal Advisory Committee Act (Pub. L. 92-463), announcement is made of the following committee meeting:

*Name of Committee:* Coastal Engineering Research Board (CERB).

*Date of Meeting:* June 7-9, 1994.

*Place:* U.S. Army Engineer Waterways Experiment Station's Coastal Engineering Research Center, Vicksburg, Mississippi.

*Time:* 8:30 a.m. to 5:30 p.m. on June 7; 8 a.m. to 5:30 p.m. on June 8; 8:30 a.m. to 10:15 a.m. on June 9.

*Theme:* Coastal Research and Development (R&D).

*Proposed Agenda:* The morning session on June 7 will consist of a report of Chief of Engineers' initiatives and action items from the previous meeting; a presentation on the history of CERB/CERC/CERC Today and CERC 21; and a presentation on the Civil Works R&D Programs. Immediately after lunch, there will be a tour of models in the J.V. Hall Building. After the tour, the meeting will reconvene and presentations will include CERC Programs; Coastal R&D Programs; Duck 94; Sandy Duck; Coastal Inlets Research Program; and Monitoring Completed Coastal Projects, Coastal Field

Data Collection Program. A tour of the Prototype Measurement and Analysis Branch Building will conclude the first day's activities. The morning of June 8 will consist of presentations including Military Coastal Work, Scanning Hydrographic Operational Airborne Lidar Survey, Dredging Research Programs and Dredging Operations and Environmental Research, Coastal Environmentally Related Work, and Civil Reimbursable Work. A tour of hydraulic models will follow lunch. After the tour, the meeting will reconvene, and presentations will include Numerical Modeling and a Summary and Future Directions. June 9 will be devoted to the recommendations of the CERB.

This meeting is open to the public; participation by the public is scheduled for 9:40 a.m. on June 9.

The entire meeting is open to the public subject to the following:

1. Since seating capacity of the meeting room is limited, advance notice of intent to attend, although not required, is requested in order to assure adequate arrangements.
2. Oral participation by public attendees is encouraged during the time scheduled on the agenda; written statements may be submitted prior to the meeting or up to 30 days after the meeting.

Inquiries and notice of intent to attend the meeting may be addressed to Colonel Bruce K. Howard, Executive Secretary, Coastal Engineering Research Board, U.S. Army Engineering Waterways Experiment Station, 3909 Halls Ferry Road, Vicksburg, Mississippi 39180-6199.

**Kenneth L. Denton,**

*Army Federal Register Liaison Officer.*

[FR Doc. 94-9263 Filed 4-15-94; 8:45 am]

BILLING CODE 3710-08-M

#### DEPARTMENT OF ENERGY

##### Bonneville Power Administration

##### Availability of the Non-Federal Participation Capacity Ownership Record of Decision

**AGENCY:** Bonneville Power Administration (BPA), Department of Energy (DOE).

**ACTION:** Record of decision (ROD) on non-federal participation capacity ownership.

**SUMMARY:** The ROD documents the Administrator's decision to proceed with Capacity Ownership for Non-Federal parties. Capacity Ownership allows non-Federal utilities to collectively purchase 725 megawatts (MW) of contract rights to use BPA's share of alternating current (AC) Intertie capacity, which was increased upon completion of the Third AC Intertie transmission project. The Third AC Intertie project increased Pacific Northwest/Pacific Southwest AC Intertie transmission capacity by 1600

MW bringing the total capacity to 4800 MW, north to south. BPA owns and/or controls about 1350 MW of this increased capacity.

**DOCUMENTS AVAILABLE:** If you would like a copy of the Non-Federal Participation Capacity Ownership ROD, please call our document request line: toll-free 800-622-4520 and ask for the Non-Federal Participation Capacity Ownership Record of Decision.

**FOR FURTHER INFORMATION CONTACT:** Ms. Cathy Ehli at 503-230-5173, or the Public Involvement Office in Portland. Telephone numbers, voice/TTY, for the Public Involvement office are: 503-230-3478 in Portland, and toll-free 800-622-4519 for the rest of the United States.

Issued in Portland, Oregon on March 25, 1994.

Stephen J. Wright,  
Assistant Administrator, Washington DC  
Liaison Bonneville Power Administration.  
[FR Doc. 94-9283 Filed 4-15-94; 8:45 am]  
BILLING CODE 6450-01-P

#### Federal Energy Regulatory Commission

[Docket No. EL94-47-000, et al.]

#### Florida Municipal Power Agency, et al. Electric Rate and Corporate Regulation Filings

April 8, 1994.

Take notice that the following filings have been made with the Commission:

##### 1. Florida Municipal Power Agency v. Florida Power & Light Company

Docket No. EL94-47-000; Docket Nos. ER93-465-000 [Not yet Consolidated]

Take notice that on March 17, 1994, Florida Municipal Power Agency (FMPA) tendered for filing a complaint against Florida Power & Light Company (FP&L) and a Motion to Consolidate with Florida Power & Light Company, Docket Nos. ER93-465-000, et al.

In its complaint FMPA seeks an order from the Commission: (1) Finding that the rate currently charged by FP&L for partial requirements (PR) service under its Wholesale Service Tariff may be unjust and unreasonable, may produce excessive revenues from FMPA, and should be subject to reduction and refund consistent with the complaint; (2) establishing a refund-effective date 60 days after the date of filing of this complaint; (3) consolidating of the consideration of the matters raised by this complaint with the ongoing proceedings in Docket Nos. ER93-465-000, et al.; and (4) affording FMPA such other relief as may be deemed appropriate.

*Comment date:* May 9, 1994, in accordance with Standard Paragraph E at the end of this notice.

##### 2. Portland General Electric Company

[Docket No. ER94-963-000]

Take notice that on February 22, 1994, Portland General Electric Company tendered for filing a Certificate of Concurrence in the above-referenced docket.

*Comment date:* April 22, 1994, in accordance with Standard Paragraph E at the end of this notice.

##### 3. Massachusetts Electric Company

[Docket No. ER94-798-000]

Take notice that Massachusetts Electric Company (Mass. Electric) on April 4, 1994, tendered an amendment to its filing in this proceeding. Mass. Electric's proposed amendment includes a Petition for Waiver of the Fuel Adjustment Clause Regulations.

*Comment date:* April 22, 1994, in accordance with Standard Paragraph E at the end of this notice.

##### 4. Montaup Electric Company

[Docket No. ER94-1062-000]

Take notice that Montaup Electric Company on March 31, 1994 tendered for filing additional information to its March 21, 1994 filing in the above-referenced docket.

*Comment date:* April 22, 1994, in accordance with Standard Paragraph E at the end of this notice.

##### 5. Ocean State Power II

[Docket No. ER94-1067-000]

Take notice that on March 21, 1994, Ocean State Power II (Ocean State II) tendered for filing the following supplement (the Supplement) to its rate schedules with the Federal Energy Regulatory Commission (FERC or the Commission).

##### Supplement No. 16 to Rate Schedule FERC No. 8

This filing requests approval of the assignment, and Ocean State II's acceptance thereof, by Newport Electric Corporation (Newport) of all of its rights and obligations under its unit power agreement (the Agreement) with Ocean State II to Montaup Electric Company (Montaup). On March 27, 1990, Newport became a wholly-owned subsidiary of Eastern Utilities Associates (EUA), a registered public utility holding company. Newport intends to become an all-requirements customer of Montaup, the bulk-power supply entity of the EUA system, and has, therefore, assigned all of its rights and obligations under the Agreement to

Montaup, such assignment to become effective on the FERC-allowed effective date for Montaup's modified all-requirements wholesale tariff, filed on March 21, 1994.

Ocean State, pursuant to Section 10.6 of the Agreement, has consented to the assignment by Newport of its rights and obligations under the Agreement to Montaup.

*Comment date:* April 22, 1994, in accordance with Standard Paragraph E at the end of this notice.

##### 6. Kansas City Power & Light Company

[Docket No. ER94-1108-000]

Take notice that on March 31, 1994, Kansas City Power & Light Company (KCPL) tendered for filing an Amendment and Associated Service Schedule as an additional service pursuant to an Interchange Agreement dated July 15, 1988, between KCPL and the Union Electric Company (UE).

In its filing, KCPL states that this Amendment and Associated Service Schedule provides for replacement of an existing tap structure and the addition of a second structure to modify an existing interconnection between KCPL and UE.

*Comment date:* April 21, 1994, in accordance with Standard Paragraph E at the end of this notice.

##### 7. Wisconsin Public Service Corporation

[Docket No. ER94-1109-000]

Take notice that on March 31, 1994, Wisconsin Public Service Corporation (WPSC), tendered for filing an amendment to its February 22, 1993, agreement with the City of Marshfield, Wisconsin pursuant to which WPSC provides Marshfield with various electric services and has provided Marshfield an option to purchase a share of a combustion turbine generating unit. The amendment reflects Marshfield's exercise of the option to purchase a share of the generating unit; modifies the parties' agreement with respect to WPSC's lease of transmission facilities from Marshfield; and makes several other changes to the agreement.

WPSC requests that the Commission waive the 60-day notice provisions of the Federal Power Act and the Commission's regulations thereunder as necessary to allow the amendment to become effective on October 1, 1993.

WPSC states that copies of this filing have been served on the City of Marshfield and the Public Service Commission of Wisconsin.

*Comment date:* April 21, 1994, in accordance with Standard Paragraph E at the end of this notice.

**8. Puget Sound Power & Light Company**

[Docket No. ER94-1110-000]

Take notice that on March 31, 1994, Puget Sound Power & Light Company (Puget) submitted a supplement to its earlier filing in the above-referenced docket of a changes in Puget Rate Schedule FERC No. 16 between the United States of America Department of Energy acting by and through the Bonneville Power Administration (Bonneville) and Puget. A copy of the supplement was served upon Bonneville.

*Comment date:* April 21, 1994, in accordance with Standard Paragraph E at the end of this notice.

**9. Puget Sound Power & Light Company**

[Docket No. ER94-1111-000]

Take notice that on March 31, 1994, Puget Sound Power & Light Company (Puget) tendered for filing, as an initial rate schedule, an unexecuted letter agreement by and between Puget and the United States of America Department of Energy acting by and through the Bonneville Power Administration (Bonneville), together with attachments thereto (the Agreement). A copy of the filing was served upon Bonneville.

Puget states that the Agreement relates to construction of bypass and related facilities in connection with service by Puget for a Bonneville wholesale customer.

*Comment date:* April 21, 1994, in accordance with Standard Paragraph E at the end of this notice.

**10. Puget Sound Power & Light Company**

[Docket No. ER94-1112-000]

Take notice that on March 31, 1994, Puget Sound Power & Light Company (Puget) tendered for filing a change to Puget Rate Schedule FERC No. 88 between Puget and Public Utility District No. 1 of Snohomish County (District). A copy of the filing was served upon District.

Puget states that under a Supplement to the Rate Schedule Puget provides Standby transmission service to District. The Supplement changes the transmission demand limit and the daily charge for such transmission service.

*Comment date:* April 21, 1994, in accordance with Standard Paragraph E at the end of this notice.

**11. Western Resources, Inc.**

[Docket No. ER94-1116-000]

Take notice that on March 31, 1994, Western Resources, Inc., (WRI) tendered for filing a proposed change in its Rate

Schedule FERC No. 264 and to Kansas Gas and Electric's (KG&E) Rate Schedule FERC No. 183. WRI states that the change is in accordance with its Electric Power, Transmission and Service Contract with Kansas Electric Power Cooperative (KEPCo) and further that the proposed change for KG&E is in accordance with the Electric Power, Transmission and Service contract between KG&E and KEPCo. Revised Exhibits B set forth Nominated Capacities for transmission, distribution and dispatch service for the contact year beginning June 1, 1994 and for the four subsequent contract years, pursuant to Article IV, Section 4.1 of Rate Schedule FERC Nos. 264 and 183. Revised Exhibits C set forth KEPCo's Nominated Capacities for the Points of Interconnection, pursuant to Article IV, Section 4.1 of Rate Schedule FERC Nos. 264 and 183. Revised Exhibits D set forth KEPCo's load forecast and KEPCo's Capacity Resources intended to provide power and energy to meet the forecast requirements for ten years into the future, pursuant to Article V, Section 5.1 of Rate Schedule FERC Nos. 264 and 183.

Copies of the filing were served upon Rate Kansas Electric Power Cooperative, Inc. and the Kansas Corporation Commission.

*Comment date:* April 21, 1994, in accordance with Standard Paragraph E at the end of this notice.

**12. Idaho Power Company**

[Docket No. ER94-1117-000]

Take notice that on March 31, 1994, Idaho Power Company tendered for filing an agreement with Sierra Pacific Power Company entitled Agreement for the Purchase, Supply and Firm Transmission of Power and Energy. Idaho Power Company has requested an effective date for the agreement of July 1, 1994.

*Comment date:* April 21, 1994, in accordance with Standard Paragraph E at the end of this notice.

**13. Public Service Electric and Gas Company**

[Docket No. ER94-1118-000]

Take notice that Public Service Electric and Gas Company (PSE&G) of Newark, New Jersey, on behalf of itself and GPU Service Corporation (GPUSC) of Parsippany, New Jersey, on April 1, 1994, tendered for filing an agreement for the sale, purchase, and/or exchange of Pennsylvania-New Jersey-Maryland Interconnection (PJM) Installed Capacity Credits. Pursuant to the agreement, the PJM Installed Capacity Credits will be sold, purchased, and/or exchanged at a

rate not to exceed the rate for purchasing capacity as set forth in the appropriate schedule of the PJM Agreement.

Copies of the filing have been served upon GPUSC and interested state commissions.

*Comment date:* April 21, 1994, in accordance with Standard Paragraph E at the end of this notice.

**14. Florida Power & Light Company**

[Docket No. ER94-1119-000]

Take notice that on April 1, 1994, Florida Power & Light Company (FPL) tendered for filing the Notices of Contract Demand for Power Years 1994, 1995 and 1996 for the following customers under Rate Schedule PR of FPL's Wholesale Electric Tariff: City of Starke; City of Jacksonville Beach; City of Green Cove Springs; and the City of Clewiston. FPL also tendered for filing the Notices of Contract Demand under Rate Schedule PR for the City of Homestead for Power Year 1994 and for the period June 1, 1995 through September 30, 1995 and the Notice of Contract Demand for the Utilities Commission, New Smyrna Beach for the period June 1, 1994 through November 28, 1994.

*Comment date:* April 21, 1994, in accordance with Standard Paragraph E at the end of this notice.

**15. Midwest Power Systems Inc.**

[Docket No. ER94-1120-000]

Take notice that on April 1, 1994, Midwest Power Systems Inc. (MPSI) tendered for filing revised Service Schedule A dated March 16, 1994, to a Facilities Agreement (Agreement) between N.W. Electric Power Cooperative (Northwest) and Iowa Power and Light Company (IPL), a/k/a MPSI.

By letter dated October 31, 1989, the Commission accepted for filing revised Service Schedules A and B (Docket No. ER89-671-000) dated January 18, 1989, between IPL and Northwest. This filing was designated Supplement Nos. 3 and 4 to IPL Rate Schedule FERC No. 40 and redesignated MPSI Rate Schedule FERC No. 9 in Docket No. ER92-784-000.

Service Schedule A, dated March 16, 1994, supersedes the Service Schedule A currently effective under the Agreement between MPSI and Northwest. The revised Service Schedule A covers the ownership, maintenance, and operation of two 13 Kv breakers at the Hamburg Substation.

MPSI states that copies of this filing were served on Northwest and the Iowa Utilities Board.



*Comment date:* April 21, 1994, in accordance with Standard Paragraph E at the end of this notice.

#### 16. Okeelanta Power Limited Partnership

[Docket No. QF94-64-000]

On April 7, 1994, Okeelanta Power Limited Partnership tendered for filing an amendment to its initial filing in this docket.

The amendment pertains to the ownership structure and technical aspects of the cogeneration facility. No determination has been made that the submittal constitutes a complete filing.

*Comment date:* April 28, 1994, in accordance with Standard Paragraph E at the end of this notice.

#### Standard Paragraphs

E. Any person desiring to be heard or to protest said filing should file a motion to intervene or protest with the Federal Energy Regulatory Commission, 825 North Capitol Street NE., Washington, DC 20426, in accordance with Rules 211 and 214 of the Commission's Rules of Practice and Procedure (18 CFR 385.211 and 18 CFR 385.214). All such motions or protests should be filed on or before the comment date. Protests will be considered by the Commission in determining the appropriate action to be taken, but will not serve to make protestants parties to the proceeding. Any person wishing to become a party must file a motion to intervene. Copies of this filing are on file with the Commission and are available for public inspection.

Lois D. Cashell,

Secretary.

[FR Doc. 94-9245 Filed 4-15-94; 8:45 am]

BILLING CODE 6717-01-P

[Docket No. EC94-11-000, et al.]

#### PacifiCorp, et al.; Electric Rate and Corporate Regulation Filings

April 11, 1994.

Take notice that the following filings have been made with the Commission:

##### 1. PacifiCorp

[Docket No. EC94-11-000]

Take notice that on March 2, 1994, PacifiCorp tendered for filing in accordance with 18 CFR 33 of the Commission's Rules and Regulations, an application seeking an order authorizing PacifiCorp to convey to the Portland General Electric Company (PGE) certain transmission facilities located in Multnomah County, Oregon.

PacifiCorp requests that, pursuant to Section 33.10 of the Commission's Regulations, the Commission accept this application for filing to be effective forty-five (45) days after the date of filing.

Copies of this filing were supplied to PGE and the Public Utility Commission of Oregon.

*Comment date:* April 25, 1994, in accordance with Standard Paragraph E at the end of this notice.

##### 2. Pennsylvania Power Company

[Docket No. ER94-664-000]

Take notice that on April 5, 1994, Pennsylvania Power Company (PPL) tendered for filing an amendment to its December 30, 1993, filing filed in this docket.

*Comment date:* April 12, 1994, in accordance with Standard Paragraph E at the end of this notice.

##### 3. Northern States Power Company (Minnesota); Northern States Power Company (Wisconsin)

[Docket No. ER94-1090-000]

Take notice that on March 28, 1994, Northern States Power Company (Minnesota) and Northern States Power Company (Wisconsin) (hereinafter jointly NSP) tendered for filing to revise and reduce the rate for purchase for resale transmission service under Rate Schedule P (Order No. 84 Service). NSP requests this rate decrease to become effective on June 1, 1994, more than sixty (60) days after the date of this filing.

*Comment date:* April 25, 1994, in accordance with Standard Paragraph E at the end of this notice.

##### 4. Maine Public Service Company

[Docket No. ER94-1094-000]

Take notice that on March 28, 1994, Maine Public Service Company (Maine Public) filed executed Service Agreements with Consolidated Edison and Niagara Mohawk Power Corporation. Maine Public states that the service agreements are being submitted pursuant to its tariff provision pertaining to the short-term non-firm sale of capacity and energy which establishes a ceiling rate at Maine public's cost of service for the units available for sale.

Maine Public has requested that the service agreements become effective on April 1, 1994 and requests waiver of the Commission's regulations regarding filing.

*Comment date:* April 25, 1994, in accordance with Standard Paragraph E at the end of this notice.

##### 5. Pennsylvania Power & Light Company

[Docket No. ER94-1097-000]

Take notice that on March 29, 1994, Pennsylvania Power & Light Company (PP&L) tendered for filing a Capacity Credit Sales Agreement (Agreement) between PP&L and Potomac Electric Power Company (PEPCO) dated March 2, 1994. The Agreement provides for the sale by PP&L to PEPCO of Daily Generating Capacity Megawatts solely for PEPCO's use in the Pennsylvania-New Jersey-Maryland (PJM) Interconnection's planned and/or accounted-for installed capacity accounting purposes.

PP&L has requested an effective date of June 1, 1994 for the Agreement, which is more than 60 days from the date of filing. PP&L is not requesting any notice period waivers.

PP&L states that a copy of its filing was served on PEPCO, the Pennsylvania Public Utility Commission, the Maryland Public Service Commission, and the District of Columbia Public Service Commission.

*Comment date:* April 25, 1994, in accordance with Standard Paragraph E at the end of this notice.

##### 6. New England Power Company

[Docket No. ER94-1098-000]

Take notice that on March 30, 1994, New England Power Company (NEP) tendered for filing a Transmission Service Agreement with Western Massachusetts Electric Company (WMECO). According to NEP, the agreement provides firm transmission service of power to the French King and Shelburne substations owned by WMECO. Inasmuch as the tendered agreement supersedes two expired contracts for the same service, NEP simultaneously seeks to terminate its Rate Schedule No. 203 and a specified contract now pending in Docket No. ER93-255-000.

*Comment date:* April 25, 1994, in accordance with Standard Paragraph E at the end of this notice.

##### 7. Kansas City Power & Light Company

[Docket No. ER94-1101-000]

Take notice that on March 30, 1994, Kansas City Power & Light Company (KCPL) tendered for filing a Transmission and Subtransmission Service Schedule as an additional Service Schedule pursuant to a Municipal Participation Agreement dated April 8, 1992, between KCPL and the City of Higginville, Missouri (City).

In its filing, KCPL states that the rates, terms and conditions for this new transaction are the same as similar

service to customers, including the City of Higginsville which currently takes Transmission and Subtransmission service. KCPL requests a proposed effective date of June 1, 1994.

*Comment date:* April 25, 1994, in accordance with Standard Paragraph E at the end of this notice.

#### 8. Montaup Electric Company

[Docket No. ER94-1102-000]

Take notice that on March 30, 1994, Montaup Electric Company filed an Exhibit A under the service agreement for Montaup's transmission service to New England Power Company under Montaup's FERC Electric Tariff, Original Volume No. 2. The Exhibit A is for the transmission of power from Taunton Municipal Lighting Plant beginning June 1, 1994. Montaup requests that the Exhibit A be permitted to become effective on that date.

*Comment date:* April 25, 1994, in accordance with Standard Paragraph E at the end of this notice.

#### 9. Florida Power & Light Company

[Docket No. ER94-1103-000]

Take notice that on March 30, 1994, Florida Power & Light Company (FPL) tendered for filing (1) Amendment Number One to Amendment No. four (Amendment Number One to Amendment Number Four) to the St. Lucie Delivery Service Agreement Between Florida Power & Light Company and Orlando Utilities Commission (OUC St. Lucie DSA), and (2) Amendment Number Five (Amendment Number Five) to the OUC St. Lucie DSA.

FPL states that both amendments have been executed by both FPL and the Orlando Utilities Commission (OUC) and that a copy of the filing was served on OUC and the Florida Public Service Commission.

*Comment date:* April 25, 1994, in accordance with Standard Paragraph E at the end of this notice.

#### 10. Puget Sound Power & Light Company

[Docket No. ER94-1114-000]

Take notice that Puget Sound Power & Light Company on March 31, 1994, tendered for filing proposed changes in its FERC Electric Service Tariff, Volume No. 1. The proposed changes would increase revenues from jurisdictional sales to Puget's nine wholesale customers by \$2,296,318 or approximately 48.1 percent based on the 12 month period ending December 31, 1994. This increase in revenue excludes the effect of any changes in state and municipal utility taxes.

The purpose of this filing is to update the rates charged to Puget's wholesale customers to reflect the significant increase in Puget's costs of purchasing and generating power as well as increased overall operating costs which have occurred since Puget's last wholesale rate increase (Docket No. ER90-116-000), which became effective on June 6, 1990.

Copies of the filing were served upon Puget's nine wholesale customers served under this tariff.

*Comment date:* April 25, 1994, in accordance with Standard Paragraph E at the end of this notice.

#### 11. Massachusetts Electric Company

[Docket No. ER94-1121-000]

Take notice that on April 1, 1994, Massachusetts Electric Company (MECo) tendered for filing a rate decrease applicable to its borderline sales customers. MECo seeks an effective date of December 1, 1993 for the rate decrease.

*Comment date:* April 25, 1994, in accordance with Standard Paragraph E at the end of this notice.

#### 12. Southern California Edison Company

[Docket No. ER94-1122-000]

Take notice that on April 1, 1994, Southern California Edison Company (Edison) tendered for filing the following amendment to the Winter Power Sale Agreement between Edison and PacifiCorp, executed on December 14, 1993.

Amendment No. 1 to the Winter Power Sale Agreement Between Southern California Edison and PacifiCorp

The Amendment provides that Edison shall make available and PacifiCorp shall be obligated to purchase an additional 100 MW of Contract Capacity beginning January 1, 1994 and an additional 100 MW of Contract Capacity beginning January 1, 1995 and Associated Energy during each Delivery Season.

Copies of this filing were served upon the Public Utilities Commission of the State of California and all interested parties.

*Comment date:* April 25, 1994, in accordance with Standard Paragraph E at the end of this notice.

#### 13. PacifiCorp

[Docket No. ER94-1123-000]

Take notice that on April 1, 1994, PacifiCorp, tendered for filing in accordance with 18 CFR Part 35 of the Commission's Rules and Regulations Amendment No. 1 to the Amendment of Agreements between PacifiCorp and

Moon Lake Electric Association (Moon Lake). Amendment No. 1 provides for the addition or deletion of PacifiCorp customers requiring wheeling and transformation service by Moon Lake.

PacifiCorp requests, the enclosed information be accepted as a supplement to PacifiCorp's Rate Schedule FERC No. 152.

Copies of this filing were supplied to Moon Lake Electric Association, the Public Utility Commission of Oregon and the Utah Public Service Commission.

*Comment date:* April 25, 1994, in accordance with Standard Paragraph E at the end of this notice.

#### 14. Northeast Utilities Service Company

[Docket No. ER94-1125-000]

Take notice that on April 1, 1994, Northeast Utilities Service Company (NUSCO) submitted for filing, on behalf of the Northeast Utilities System Companies, a proposed FERC Electric Tariff No. 6—System Power Sales and Exchanges. NUSCO states that the proposed Tariff provides for negotiated system power sales and exchanges at prices at or below full cost of service. NUSCO requests that the proposed tariff be made effective 60 days after receipt by the Commission.

*Comment date:* April 25, 1994, in accordance with Standard Paragraph E at the end of this notice.

#### 15. Medina Power Company

[Docket No. QF91-040-000]

Take notice that on January 19, 1994, the Niagara Mohawk Power Corporation (Niagara Mohawk) filed a motion with the Federal Energy Regulatory Commission (Commission) seeking the revocation of Medina Power Company's (Medina) self-certification of qualifying facility (QF) status for Medina's Cogeneration facility.

On December 5, 1990, Medina, in Docket No. QF91-040-000, filed with the Commission a notice of self-certification as a QF pursuant to 18 CFR 292.207(a)(2).

Niagara Mohawk is the purchaser of electric power generated by Medina's QF. According to Niagara Mohawk, Medina's QF does not currently and has not had in the past, a thermal output customer. Niagara Mohawk states that during a plant visit to Medina's QF in 1992, Medina represented that a greenhouse would be the facility's thermal output customer, but that Medina subsequently discontinued its plans to construct a greenhouse. Thus, Niagara Mohawk contends that Medina's QF is not in compliance with § 292.205(a) of the Commission's regulations.

Comment date: May 11, 1994, in accordance with Standard Paragraph E at the end of this notice.

#### Standard Paragraphs

E. Any person desiring to be heard or to protest said filing should file a motion to intervene or protest with the Federal Energy Regulatory Commission, 825 North Capitol Street, N.E., Washington, D.C. 20426, in accordance with Rules 211 and 214 of the Commission's Rules of Practice and Procedure (18 CFR 385.211 and 18 CFR 385.214). All such motions or protests should be filed on or before the comment date. Protests will be considered by the Commission in determining the appropriate action to be taken, but will not serve to make protestants parties to the proceeding. Any person wishing to become a party must file a motion to intervene. Copies of this filing are on file with the Commission and are available for public inspection.

Lois D. Cashell,  
Secretary.

[FR Doc. 94-9244 Filed 04-15-94; 8:45 am]

BILLING CODE 6717-01-P

[FERC Docket Nos. CP93-258-000, et al.  
CA State Clearinghouse No. 94032040]

#### Mojave Pipeline Co.; Preparation/Intent to Prepare a Joint Draft Environmental Impact Report/Statement for the Proposed Mojave Northward Expansion Project and Request for Comments on Environmental Issues

April 12, 1994.

The staff of the Federal Energy Regulatory Commission (FERC or Commission) will prepare a joint environmental impact report/statement (EIR/EIS) with the California State Lands Commission (SLC) that will discuss the environmental impacts of the construction and operation of facilities proposed in Mojave Pipeline Company's Northward Expansion Project.<sup>1</sup> The FERC will use this EIR/EIS in its decision-making process (whether or not to certificate the proposed project).

The SLC will be the lead State agency for California and the FERC will be the lead Federal agency in the preparation of this joint EIR/EIS. The joint document, which will avoid much duplication of environmental analyses, will satisfy the requirements of the California Environmental Quality Act

<sup>1</sup> Mojave Pipeline Company's application was filed with the Commission pursuant to section 7 of the Natural Gas Act and part 157 of the Commission's regulations.

(CEQA) and the National Environmental Policy Act (NEPA).

The Bureau of Land Management (BLM) will be cooperating with the FERC in the preparation of the EIR/EIS because of the significant amount of BLM-managed land that the proposal would affect. The other Federal agencies we are asking to cooperate (see appendix 1) may choose to participate once they have evaluated Mojave's proposal relative to their respective responsibilities.<sup>2</sup>

#### Summary of the Proposed Facilities

Mojave Pipeline Company (Mojave) has an existing natural gas transmission system which begins near Topock, Arizona and terminates near Bakersfield, California. Mojave requests FERC authorization to construct and operate certain pipeline and compression facilities that will extend its system into Central and Northern California (Northward Expansion Project). These additional facilities would enable Mojave to transport 475 million cubic feet per day of natural gas to customers in the San Joaquin Valley and Northern California (San Francisco Bay Area and Sacramento).

Mojave's application proposes two facility schemes. One plan includes the facilities Mojave would construct in the event the Kern River Gas Transmission Company (Kern River) also expands its existing system. The second plan includes the facilities Mojave would construct without any expansion by Kern River. This EIR/EIS will analyze the most construction-intensive combination of Mojave facilities.<sup>3</sup>

The proposed Northward Expansion Project consists of the following facilities:

- 557 miles of new pipeline with diameters ranging from 4 inches to 30 inches;
- 100 miles of 30-inch-diameter looping pipeline;<sup>4</sup>
- Three new compressor stations in California with a total of 73,058 horsepower (hp) of compression, and

<sup>2</sup> The appendices referenced in this notice are not being printed in the *Federal Register*. Copies are available from the Commission's Public Reference Branch, room 3104, 941 North Capitol Street, N.E., Washington, DC 20426 or call (202) 208-1371. Copies of the appendices were sent to all those receiving this notice in the mail.

<sup>3</sup> Kern River's expansion application, filed with the FERC in November 1991 (Docket No. CP92-198-000), is pending before the Commission. A separate environmental review of Kern River's proposed facilities was conducted by the Commission staff in the *Kern River Expansion Project Environmental Assessment*, issued April 1993.

<sup>4</sup> A loop is a segment of pipeline installed adjacent to an existing pipeline and connected to it at both ends.

24,470 hp of additional compression at Mojave's existing compressor station in Topock, Arizona; and

- Construction of 55 new meter stations and the modification of 1 existing meter station.

The general locations of the facilities proposed by Mojave are shown in appendix 2. A detailed listing of the facilities is in appendix 3.

Mojave informed the Commission that it plans to amend its application after the issuance of this notice. Specific details regarding any changes to the proposed project will be available at the public scoping meetings. The landowners who would be affected by that amendment will receive a copy of this notice. At a minimum Mojave expects the amendment to include:

- (1) An alternative pipeline alignment between Bakersfield and Lindsay;
- (2) An extension of its Palo Alto Segment of approximately 30 miles to a location near Hunters Point;
- (3) An alternative siting of its Famoso Compressor Station near Lindsay; and
- (4) An alternative pipeline alignment to avoid the Contra Costa Water District's Los Vaqueros Reservoir Project.

Several of the customers receiving gas from Mojave as part of this project will need to build pipelines to take the gas delivered to them. Although these facilities are not under the jurisdiction of the FERC, they will be discussed in the EIR/EIS.

#### Land Requirements for Construction

Mojave proposes to build its new mainline and pipeline segments in construction rights-of-way ranging from 30 to 75 feet wide. After construction, 0 to 30 feet would be maintained as permanent easement. Specific widths of the rights-of-way vary, depending on the proposed pipeline diameter for specific locations. The proposed loops would be built parallel and adjacent to Mojave's existing pipelines, using as much of the existing rights-of-way as possible for the construction right-of-way. The three new compressor stations would require approximately 20 acres each.

Additional temporary work space may be required at major river, road or railroad crossings, or where similar obstacles are encountered. Mojave would purchase the temporary and permanent easements necessary for constructing the project.

Construction of the pipelines would normally follow standard pipeline construction methods: right-of-way clearing and grading; trenching; pipe stringing, bending, welding, joint coating, and lowering in; backfilling of the trench; and cleanup and restoration.

Mojave proposes to implement erosion control and revegetation measures and to use special construction techniques for wetland and water crossings and for construction in residential areas. These construction procedures and mitigation plans will be discussed further in the Draft EIR/EIS.

Pipeline loops in or adjacent to existing rights-of-way would generally require less clearing and grading. Rotary-wheeled ditching machines, backhoes, or rippers would be used to excavate a sufficiently deep trench. For buried pipelines, the U.S. Department of Transportation (DOT) requires a minimum of 30 inches of cover in normal soils and 18 inches in consolidated rock. In populated areas, this increases to 36 and 24 inches of cover, respectively. Blasting would be required when areas of consolidated rock are encountered.

Pipeline segments would be designed according to DOT minimum safety standards and specifications (49 CFR part 192) and would be hydrostatically tested before being placed in service. Mojave would be required to obtain appropriate Federal and state discharge permits prior to hydrostatic testing. No chemicals would be used during this testing.

#### The EIR/EIS Process

The NEPA requires the Commission to take into account the environmental impacts that could result from a major Federal action whenever it considers the issuance of a Certificate of Public Convenience and Necessity. The California SLC, as a cooperating state agency, is required to consider the same potential impacts within the State of California under the CEQA. The EIR/EIS we are preparing will give both the SLC and the Commission the information we need to do that.

NEPA (and CEQA) also requires us to discover and address concerns the public may have about proposals. We call this "scoping". The main goal of the scoping process is to focus the analysis in the EIR/EIS on the important environmental issues, and to separate those issues that are insignificant and do not require detailed study.

The EIR/EIS will discuss impacts that *could* occur as a result of the construction and operation of the proposed project. These impacts may include, but are not limited to:

- Geology and Soils
  - Geological and seismic hazards
  - Erosion control
  - Right-of-way restoration
- Water Resources
  - Impact on potable water supplies
  - Impact on wetland hydrology

- Effect of construction in areas with shallow, contaminated groundwater
- Effect of pipeline crossings on streams and canals

#### Biological Resources

- Short- and long-term effects of right-of-way clearing and maintenance in wetlands, forests, and riparian areas
- Effects of habitat alteration
- Impact on threatened and endangered species
- Impact on fisheries

#### Cultural Resources

- Impact on historic and prehistoric sites
- Native American and tribal concerns
- Impact on the Los Vaqueros Historic District and the California Historic Landmarks of the Black Diamond Mines and the Desert Training Maneuver Area

#### Socioeconomics

- Effects of temporary population growth
- Effects of increased employment and taxes on local economy

#### Air quality

- Effect of compressor stations emissions on air quality

#### Noise

- Effect of compressor stations operation on nearby noise-sensitive receptors

#### Reliability and Safety

- Assessment of hazards associated with natural gas pipelines

#### Land Use

- Impact on California Desert Conservation District, Black Diamond Mines Regional Preserve, Contra Loma Regional Park and Reservoir, Sycamore Grove Regional Park, Mission Peaks Regional Preserve, Sunol Regional Wilderness, and Levin County Park

- Impact on commercial crop production

- Impact on industrial areas
- Effect of rights-of-way and aboveground facilities on visual aesthetics in residential and scenic areas

- Impact on Concord Naval Weapons Station, Lemoore Naval Air Station, Edwards Air Force Base
- Consistency with city and county land use plans

- Impact on residences

#### Paleontology

- Impact on significant fossil resources discovered during pipeline construction

#### Alternatives

- Route variations to avoid sensitive areas

#### Cumulative Impacts

- Identification of related projects
- Analysis of cumulative impacts and mitigation measures

We will also evaluate possible alternatives to the project and recommend specific mitigation measures to lessen or avoid impacts on the various resource areas.

Our independent analysis of the issues will result in the publication of a Draft EIR/EIS which will be mailed to Federal, state, and local agencies, public interest groups, interested individuals, affected landowners, newspapers, libraries, and the Commission's official service list for these proceedings. A 45-day comment period will be allocated for the review of the Draft EIR/EIS. We will consider all comments on the Draft EIR/EIS and revise the document, as necessary, before issuing a Final EIR/EIS. The Final EIR/EIS will include our response to each comment received.

#### Public Participation and Scoping Meetings

You can make a difference by sending a letter with your specific comments or concerns about the project. You should focus on the potential environmental effects of the proposal, alternatives to the proposal (including alternative routes), and measures to avoid or lessen environmental impact. The more specific your comments, the more useful they will be. Please follow the instructions below to ensure that your comments are received and properly recorded:

- Address the letter to: Ms. Lois Cashell, Secretary, Federal Energy Regulatory Commission, 825 North Capitol Street NE., Washington, DC 20426;
- Reference Docket Nos. CP93-258-000, *et al.*;
- Send a *copy* of the letter to the following individuals:

Michael J. Boyle, EIS Project Manager, Federal Energy Regulatory Commission, Room 7312, 825 North Capitol Street NE., Washington, DC 20426

Mary Griggs, EIR Project Manager, State Lands Commission, 1807 13th Street, Sacramento, CA 95814.

- Mail comments before May 20, 1994.

In addition to asking for written comments, we invite you to attend any of the joint public scoping meetings the FERC and SLC will conduct. The locations and times for these meetings are listed on the next page. Requests to hold additional public scoping meetings will be considered.

The public meetings will be designed to provide you with more detailed information and another opportunity to offer your comments on the proposed project. Those wanting to speak at the

meetings can call the EIS Project Manager to pre-register their names on the speaker list. Those people on the speaker list prior to the date of the meeting will be allowed to speak first. A second speaker list will be developed at each meeting. Priority will be given to people representing groups. A transcript of each meeting will be made so that your comments will be accurately recorded.

#### Becoming an Intervenor

In addition to involvement in the EIR/EIS scoping process, you may want to become an official party to the FERC proceedings by becoming an intervenor. Among other things, intervenors have the right to receive copies of case-related Commission documents and filings by other intervenors. Likewise, each intervenor must provide copies of its filings to all other parties. If you want to become an intervenor, you must file a Motion to Intervene according to Rule 214 of the Commission's Rules of Practice and Procedure (18 CFR 385.214) which is attached as appendix 4.

The date for filing timely motions to intervene in this proceeding has passed. Therefore, parties now seeking to file late interventions must show good cause, as required by § 385.214(b)(3), why this time limitation should be waived. Environmental issues have been viewed as good cause for late intervention. You do not need intervenor status to have your scoping comments considered or to speak at a meeting.

#### Schedule for EIR/EIS Public Scoping Meetings

Palo Alto, California, May 9, 1994; 7:00 p.m., Lucie Stern Community Center, 1305 Middlefield Road, (415) 329-2261

Livermore, California, May 10, 1994; 7:00 p.m., Junction Middle School, 298 Junction Avenue, (510) 606-3234

Fresno, California, May 11, 1994; 7:00 p.m., Ted C. Wills Community Center, 770 North San Pablo, (209) 488-1035

Barstow, California, May 12, 1994; 7:00 p.m., Holiday Inn—Barstow, 1511 East Main Street, (619) 256-5673

#### Environmental Mailing List

If you don't want to send comments at this time but still want to keep informed and receive copies of the Draft and Final EIR/EIS, please return the Information Request (see appendix 5). If you do not return the Information Request, you will be taken off the mailing list.

#### Additional Questions?

Additional information about the proposed project is available from Mr. Michael J. Boyle, EIS Project Manager, (202) 208-0918.

Information concerning the involvement of the California SLC in the EIR/EIS may be obtained from Ms. Mary Griggs, EIR Project Manager, (916) 322-0354.

Request for information regarding the involvement of the Bureau of Land Management as a cooperating agency in the environmental analysis process may be addressed to: Mr. Stephen L. Johnson, Pipeline Project Manager, BLM—California Desert District, 6221 Box Springs Blvd., Riverside CA 92507-0714, (909) 697-5233.

Lois D. Cashell,

Secretary.

[FR Doc. 94-9205 Filed 4-15-94; 8:45 am]

BILLING CODE 6717-01-P

[Project Nos. 11458-000, et al.]

#### Hydroelectric Applications [Washington Hydro Development Company, Inc., et al.]; Applications

Take notice that the following hydroelectric applications have been filed with the Commission and are available for public inspection:

1 a. *Type of Application*: Preliminary Permit.

b. *Project No.*: 11458-000.

c. *Date filed*: February 1, 1994.

d. *Applicant*: Washington Hydro Development Company, Inc.

e. *Name of Project*: O'Toole Creek Hydroelectric Project.

f. *Location*: On O'Toole Creek in Skagit County, Washington, near Sedro Woolley. T35N. R7E. sections 20, 29, 28, and 33.

The project would partially occupy lands within the Mt. Baker-Snoqualmie National Forest.

g. *Filed Pursuant to*: Federal Power Act, 16 USC §§ 791(a)-825(r)

h. *Applicant Contact*:

Martin W. Thompson, Vice President, Washington Hydro Development Company, Inc., 19515 North Creek Parkway, Suite 310, Bothell, WA 98011-8208, (206) 487-6541

Phil Hilgert, Beak Consultants, 12931 NE 126th Place, Kirkland, WA 98034-7716, (206) 823-6919

Frank Frisk, Jr., Attorney at Law, 1054 31st Street, NW #125, Washington, DC 20007, (202) 333-8433

Lon Covin, Hydro West Group, Inc., 1422 130th Avenue NE, Bellevue, WA 98005 (206) 455-0234.

i. *FERC Contact*: Ms. Deborah Frazier-Stutely (202) 219-2842.

j. *Comment Date*: June 6, 1994.

k. *Description of Project*: The proposed project would consist of: (1) A 11-foot-high, 46-foot-long diversion dam with a crest elevation of 2,105 feet msl; (2) a 33-foot-wide, 67-foot-long intake structure consisting of fish screens, trashracks, and an intake gate; (3) a 36-inch-diameter, 10,782-foot-long steel penstock; (4) a powerhouse containing a single generating unit with an installed capacity of 7,150 kW, producing an estimated average annual energy output of 29,500,000 kWh; (5) a tailrace; (6) approximately 6,389 feet of new access road; and (7) a 3-mile-long, 34.5-kV transmission line tying into an existing line.

The applicant estimates the cost of the studies to be conducted under the preliminary permit at \$100,000. No new roads will be needed for the purpose of conducting these studies.

l. *Purpose of Project*: Project power would be sold to a local utility.

m. This notice also consists of the following standard paragraphs: A5, A7, A9, A10, B, C, and D2.

2 a. *Type of Application*: New License.

b. *Project No.*: 2290-006.

c. *Date filed*: December 27, 1991.

d. *Applicant*: Southern California Edison Company.

e. *Name of Project*: Kern River # 3.

f. *Location*: In Sequoia National Forest, on the North Fork Kern River, in Kern and Tulare Counties, California. Townships 23-27 S, Ranges 31-33 E.

g. *Filed Pursuant to*: Federal Power Act 16 U.S.C. 791(a)-825(r).

h. *Applicant Contact*: Mr. Gary Dudley, Southern California Edison Company, P.O. Box 800, Rosemead, CA 91770.

i. *FERC Contact*: Michael Spencer at (202) 219-2846.

j. *Comment Deadline*: Sixty days from the issuance date of the notice.

k. *Status of Environmental Analysis*: This application is ready for environmental analysis at this time—see attached paragraph D9. Except that comments, recommendations, terms and conditions, or prescriptions pertaining to whitewater boating are not being solicited because further additional information has been requested that includes a boating study to be conducted in May and June, 1994. Comments on that information will be solicited when it is filed with the Commission.

l. *Description of Project*: The project would consist of: (1) the 26-foot-high Fairview dam on the North Fork Kern River; (2) the 5-foot-high Salmon Creek diversion dam; (3) the 8-foot-high Corral Creek diversion dam; (4) tunnels

totalling 60,270 feet in length; (5) concrete flumes totalling 4,600 feet in length; (6) a 1,146-foot-long steel pipe siphon; (7) a forebay; (8) two 2,500-foot-long penstocks with diameters varying between 84 inches to 60 inches; (9) a powerhouse containing two generating units with a combined installed capacity of 40.2 MW and an average annual generation of 186,357 MWh; (10) three 66 kV transmission lines, one 45 miles long, one 27 miles long and one 1,947 feet long; and (11) appurtenant facilities.

The Licensee is not proposing any changes to the existing project works.

**m. Purpose of Project:** All project energy generated would be utilized by the Licensee.

**n.** This notice also consists of the following standard paragraphs: D9

**o. Available Locations of Application:** A copy of the application, as amended and supplemented, is available for inspection and reproduction at the Commission's Public Reference and Files Maintenance Branch, located at 941 North Capitol Street NE., room 3104, Washington, DC 20426, or by calling (202) 208-1371. A copy is also available for inspection and reproduction at the Southern California Edison Company, located at 2244 Walnut Grove Avenue, Rosemead, California 91770 or by calling Mr. Gary Dudley at (818) 302-8946.

**3a. Type of Application:** Preliminary Permit.

**b. Project No.:** 11456-000.

**c. Date Filed:** January 11, 1994.

**d. Applicant:** Point Marion Hydro Associates.

**e. Name of Project:** Point Marion.

**f. Location:** On the Monongahela River, Borough of Point Marion, Fayette County, Pennsylvania.

**g. Filed Pursuant to:** Federal Power Act, 16 U.S.C. §§ 791(a)-825(r).

**h. Applicant Contact:** Mr. V. James Dunlevy, 185 Genesee Street, Suite 1518, Utica, NY 13501, (315) 793-0366.

**i. FERC Contact:** Charles T. Raabe (dt) (202) 219-2811.

**j. Comment Date:** June 6, 1994.

**k. Description of Project:** The proposed project would utilize the existing Corps of Engineers' Point Marion Dam and Reservoir and would consist of: (1) a powerhouse containing one 5-MW horizontal pit turbine/generator; (2) 4.16 generator leads; (3) a 4.16/25-kV, 2,500 kVA transformer; (4) a 528-foot-long transmission line; and (5) appurtenant facilities.

Applicant estimates that the average annual generation would be 17.1 GWh and that the cost of the studies under the permit would be \$85,000.

**l.** This notice also consists of the following standard paragraphs: A5, A7, A9, A10, B, C & D2.

**4 a. Type of Application:** New License.

**b. Project No.:** 2334-001.

**c. Date Filed:** December 23, 1991.

**d. Applicant:** Western Massachusetts Electric Company.

**e. Name of Project:** Gardners Falls Project.

**f. Location:** On the Deerfield River, Franklin County, Massachusetts.

**g. Filed Pursuant to:** Federal Power Act, 16 U.S.C. 791(a)-825(r).

**h. Applicant Contact:** Mr. R.A. Reckert, Western Massachusetts Electric Company, P.O. Box 270, Hartford, CT 06141-0270, (203) 665-5315.

**i. FERC Contact:** Michael Dees (202) 219-2807.

**j. Deadline Date:** See paragraph D9.

**k. Status of Environmental Analysis:** This application has been accepted for filing and is ready for environmental analysis at this time—see attached standard paragraph D9.

**l. Description of Project:** The project structures consist of a dam and impoundment, a power canal, powerhouse, tailrace, and appurtenant facilities. Applicant proposes to operate the project at the same electric capacity (3.58 MW). The proposed average annual generating capacity is 15,740 MWh using the four existing active turbines and a hydraulic capacity of 1,420 cfs.

In detail, the project components are described as follows:

(1) A concrete gravity dam with an ogee type spillway and masonry abutments. The dam is 337 feet long with a maximum height of 30 feet. Permanent crest elevation is 332.79 feet msl with flash board elevation of 334.79 feet msl. The resulting impoundment is 3,200 feet long with approximately 21 acres of surface area at normal full pond. The impoundment has 190 acre-feet of gross storage and 37.2 acre-feet of usable storage.

(2) A brick and concrete powerhouse equipped with four active turbines with (a) a rated capacity of 3.58 MW, (b) a hydraulic capacity of 1,420 cfs and a proposed average annual generation of 15,740 MWh, and (c) a gross head of 38.1 feet.

(3) A 1300 foot power canal 31 feet wide and 15 feet deep.

(4) A double circuit 13.8 kV transmission line which extends over the river at the tailrace. The transmission line connects the Gardners Falls project to the Montague substation. However, WMECO states that the line is not part of this project.

**m. Purpose of Project:** The purpose of the project is to generate electric energy for sale to applicant's customers.

**n.** This notice also consists of the following standard paragraphs: A4 and D9.

**o. Available Location of Application:** A copy of the application, as amended and supplemented, is available for inspection and reproduction at the Commission's Public Reference and Files Maintenance Branch, located at 941 North Capitol Street, NE., room 3104, Washington, DC 20426, or by calling (202) 208-1371. A copy is also available for inspection and reproduction at Western Massachusetts Electric Company, Hartford, CT 06141-0270.

**p. Scoping Process:** In gathering background information for preparation of the environmental document for the issuance of a Federal hydropower license, staff of the Federal Energy Regulatory Commission, is using a scoping process to identify significant environmental issues related to the construction and operation or the continued operation of hydropower projects. The staff will review all issues raised during the scoping process and identify issues deserving of study and also deemphasize insignificant issues, narrowing the scope of the environmental assessment as well. If preliminary analysis indicates that any issues presented in the scoping process would have little potential for causing significant impacts, the issue or issues will be identified and the reasons for not providing a more detailed analysis will be given.

**q. Request for Scoping Comments:** Federal, state, and local resource agencies; licensees, applicants and developers; Indian tribes; other interested groups and individuals, are requested to forward to the Commission, any information that they believe will assist the Commission staff in conducting an accurate and thorough analysis of the site-specific and cumulative environmental effects of the proposed licensing activities of the project(s). Therefore you are requested to provide information related to the following items:

- Information, data, maps or professional opinion that may contribute to defining the geographical and temporal scope of the analysis and identifying significant environmental issues.

- Identification of and information from any other EIS or similar study (previous, on-going, or planned) relevant to the proposed licensing activities in the subject river basin.

- Existing information and any data that would aid in describing the past and present effects of the project(s) and other developmental activities on the physical/chemical, biological, and socioeconomic environments. For example, fish stocking/management histories in the subject river, historic water quality data and the reasons for improvement or degradation of the quality, any wetland habitat loss or proposals to develop land and water resources within the basin.

- Identification of any federal, state or local resource plans and future project proposals that encompass the subject river or basin. For example, proposals to construct or operate water treatment facilities, recreation areas, or implement fishery management programs.

- Documentation that would support a conclusion that the project(s) does not contribute, or does contribute to adverse and beneficial cumulative effects on resources and therefore should be excluded for further study or excluded from further consideration of cumulative impacts within the river basin. Documentation should include, but not limited to: how the project(s) interact with other projects within the river basin or other developmental activities; results from studies; resource management policies; and, reports from federal, state, and local agencies.

Comments concerning the scope of the environmental document should be filed by the deadline date.

5 a. *Type of Application:* Minor License.

b. *Project No.:* 11433-000.

c. *Date filed:* September 8, 1993.

d. *Applicant:* Town of Madison, Department of Electric Works.

e. *Name of Project:* Sandy River Hydroelectric Project.

f. *Location:* On the Sandy River in the Towns of Starks and Norridgewock, Somerset County, Maine.

g. *Filed Pursuant to:* Federal Power Act 16 U.S.C. 791 (a)-825(r).

h. *Applicant Contact:* George Stoutamy, Superintendent, P.O. Box 190, Madison, ME 04950, (207) 696-4401.

i. *FERC Contact:* Mary C. Golato (202) 219-2804.

j. *Deadline Date for Interventions and Protests, and also for Comments, Recommendations, Terms & Conditions, and Prescriptions:* June 6, 1994.

k. *Status of Environmental Analysis:* This application is accepted for filing and is ready for environmental analysis at this time—see attached D4.

l. *Description of Project:* The proposed project consists of the following features: (1) An existing dam 331.4 feet long and 14.9 feet high; (2) an existing

reservoir with a surface area of 150 acres, a drainage area of 578 square miles, and a gross storage capacity of 1,050 acre-feet; (3) an existing intake canal; (4) an existing powerhouse containing two existing turbine-generator units with a total installed capacity of 547 kilowatts; (5) an existing 7.2-kilovolt transmission line; and (6) appurtenant facilities. The average annual generation for the project is 3,000,000 kilowatthours. The owner of the project facilities is the Town of Madison, Department of Electric Works. This is an unlicensed project.

m. *Purpose of Project:* All project energy generated would be utilized by the applicant for sale to its customers.

n. This notice also consists of the following standard paragraphs: A2, A3, A9, B1, and D4.

o. *Available Locations of Application:* A copy of the application is available for inspection and reproduction at the Commission's Public Reference and Files Maintenance Branch, located at 941 North Capitol Street NE, room 3104, Washington, DC 20426, or by calling (202) 219-1371. A copy is also available for inspection and reproduction at Mr. George Stoutamy, P.O. Box 190, Madison, Wisconsin 04950, at (207) 696-4401.

p. *Scoping Process:* In gathering background information for preparation of the environmental document for the issuance of a Federal hydropower license, staff of the Federal Energy Regulatory Commission, is using a scoping process to identify significant environmental issues related to the construction and operation or the continued operation of hydropower projects. The staff will review all issues raised during the scoping process and identify issues deserving of study and also deemphasize insignificant issues, narrowing the scope of the environmental assessment as well. If preliminary analysis indicates that any issues presented in the scoping process would have little potential for causing significant impacts, the issue or issues will be identified and the reasons for not providing a more detailed analysis will be given.

q. *Request for Scoping Comments:* Federal, state, and local resource agencies; licensees, applicants and developers; Indian tribes; other interested groups and individuals, are requested to forward to the Commission, any information that they believe will assist the Commission staff in conducting an accurate and thorough analysis of the site-specific and cumulative environmental effects of the proposed licensing activities of the project(s). Therefore you are requested

to provide information related to the following items:

- Information, data, maps or professional opinion that may contribute to defining the geographical and temporal scope of the analysis and identifying significant environmental issues.

- Identification of and information from any other EIS or similar study (previous, on-going, or planned) relevant to the proposed licensing activities in the subject river basin.

- Existing information and any data that would aid in describing the past and present effects of the project(s) and other developmental activities on the physical/chemical, biological, and socioeconomic environments. For example, fish stocking/management histories in the subject river, historic water quality data and the reasons for improvement or degradation of the quality, any wetland habitat loss or proposals to develop land and water resources within the basin.

- Identification of any federal, state or local resource plans and future project proposals that encompass the subject river or basin. For example, proposals to construct or operate water treatment facilities, recreation areas, or implement fishery management programs.

- Documentation that would support a conclusion that the project(s) does not contribute, or does contribute to adverse and beneficial cumulative effects on resources and therefore should be excluded for further study or excluded from further consideration of cumulative impacts within the river basin. Documentation should include, but not limited to: How the project(s) interact with other projects within the river basin or other developmental activities; results from studies; resource management policies; and, reports from federal, state, and local agencies.

Comments concerning the scope of the environmental assessment should be filed by the deadline date.

6 a. *Type of Application:* Revised Project Boundary Maps.

b. *Project No:* 199-081.

c. *Date Filed:* September 27, 1993.

d. *Applicant:* South Carolina Public Service Authority.

e. *Name of Project:* Santee-Cooper Project.

f. *Location:* Berkeley County, South Carolina.

g. *Filed Pursuant to:* Federal Power Act, 16 U.S.C. 791(a)-825(r).

h. *Applicant Contact:* Mr. Robert Petracca, Vice President, Property and Transportation, One Riverwood Drive, P.O. Box 2946101, Moncks Corner, SC 29461-2901, (803) 761-4011.

i. *FERC Contact:* Dan Hayes, (202) 219-2660.

j. *Comment Date:* May 25, 1994.

k. *Description of Project:* The licensee for the Santee-Cooper Project has filed a proposal to allow Mr. R.G. Kozlowski to construct a boat slip in an existing canal. The licensee proposes to permit dredging and widening of the canal to create a 30' x 50' 2.5' deep basin at a property known as 108 Mourning Dove Drive, Bonneau Beach, SC.

l. This notice also consists of the following standard paragraphs: B, C1, and D2.

7 a. *Type of Application:* Revised Project Boundary Maps.

b. *Project No.:* 4129-038.

c. *Date Filed:* December 28, 1993.

d. *Applicant:* Olcese Water District.

e. *Name of Project:* Rio Bravo Project.

f. *Location:* Kern County, California.

g. *Filed Pursuant to:* Federal Power Act, 16 U.S.C. 791(a)-825(r).

h. *Applicant Contact:* Mr. Edwin E. Hudson, Kern Hydro Partners, 1666 East Cypress Avenue, suite 4, Redding, CA 96002, (916) 221-1423.

i. *FERC Contact:* Dan Hayes, (202) 219-2660.

j. *Comment Date:* May 25, 1994.

k. *Description of Project:* The licensee for the Rio Bravo Project filed a revised boundary exhibit that shows easements obtained to conduct an annual whitewater slalom race. The licensee states the easements were obtained in accordance with Article 40 of the Rio Bravo Project license and the approved Whitewater Slalom Race Plan.

l. This notice also consists of the following standard paragraphs: B, C1, and D2.

8 a. *Type of Application:* Preliminary Permit.

b. *Project No.:* 11455-000.

c. *Date filed:* March 16, 1994.

d. *Applicant:* Rock River Power & Light Corporation.

e. *Name of Project:* Lake Eau Claire Dam Project.

f. *Location:* On the Eau Claire River, Eau Claire County, Wisconsin.

g. *Filed Pursuant to:* Federal Power Act 16 U.S.C. 791(a)-825(r).

h. *Applicant Contact:* Mr. Thomas J. Reiss, Jr., President, Rock River Power and Light Corporation, P.O. Box 553, 319 Hart Street, Watertown, WI 53094, (414) 261-7975.

i. *FERC Contact:* Mary Golato (202) 219-2804.

j. *Comment Date:* June 13, 1994.

k. *Description of Project:* The proposed project would consist of the following facilities: (1) An existing dam 40 feet high and 170 feet long; (2) an existing impoundment with a surface area of 793 acres, a maximum depth of

25 feet and a volume of 11,328 acre-feet; (3) a proposed powerhouse consisting of one turbine-generator unit rated at 800 kilowatts; (4) a proposed 4,160-volt transmission 400 feet long; and (5) appurtenant facilities. The average annual generation is estimated to be 1,853,000 kilowatthours. The estimated cost of the studies is \$30,000.

l. This notice also consists of the following standard paragraphs: A3, A5, A7, A9, A10, B, C, and D2.

9 a. *Type of Application:* Preliminary Permit.

b. *Project No.:* 11463-000.

c. *Date Filed:* March 22, 1994.

d. *Applicant:* White Hydropower Company.

e. *Name of Project:* Coralville Hydro Project.

f. *Location:* On the Iowa River, near Iowa City in Johnson County, Iowa.

g. *Filed Pursuant to:* Federal Power Act 16 U.S.C. 791(a)-825(r).

h. *Applicant Contact:* Mr. Mitchell M. White, White Hydropower Company, 1855 Glendale Road, Clinton, IA 52732, (319) 242-1776.

i. *FERC Contact:* Ed Lee (202) 219-2809.

j. *Comment Date:* June 13, 1994.

k. *Description of Project:* The proposed project would utilize the U.S. Army Corps of Engineers' Coralville Dam and Reservoir, and would consist of the following new facilities: (1) A steel penstock; (2) a powerhouse containing two generating units for a total installed capacity of 12 MW; (3) a tailrace; (4) a .5-mile-long, 13.8-kV transmission line; and (5) appurtenant facilities. The average annual generation would be 52.56 GWh. The applicant estimates that the cost of the studies under the terms of the permit would be \$150,000. All power generated would be sold to a local utility company. The project lock and dam is owned and operated by the U.S. Army Corps of Engineers, District Engineer, Clock Tower Building, Rock Island, IL 61201.

l. This notice also consists of the following standard paragraphs: A5, A7, A9, A10, B, C, and D2.

10 a. *Type of Application:* Original Major License.

b. *Project No.:* 11408-000.

c. *Date filed:* April 28, 1993.

d. *Applicant:* Niagara Mohawk Power Corporation.

e. *Name of Project:* Salmon River Hydroelectric Project.

f. *Location:* On the Salmon River in the Towns of Redfield and Orwell, Oswego County, New York.

g. *Filed Pursuant to:* Federal Power Act, 16 U.S.C. 791(a)-825(r).

h. *Applicant Contact:* Mr. Jerry Sabattis, P.E., Niagara Mohawk Power

Corporation, 300 Erie Boulevard West, Syracuse, NY 13202, (315) 474-1511.

i. *FERC Contact:* Mary Golato, Project Manager, (202) 219-2804.

j. *Deadline Date:* For written comments on scoping (environmental issues)—See attached D10.

k. *Status of Environmental Analysis:* The application is ready for environmental analysis at this time—see attached paragraph D10.

l. *Intent To Prepare An Environmental Assessment And Conduct Public Scoping Meetings and Site Visit:* The Commission staff intends to prepare an Environmental Assessment (EA) on the hydroelectric project in accordance with the National Environmental Policy Act. The EA will objectively consider both site-specific and cumulative environmental impacts of the project and reasonable alternatives, and will include an economic, financial and engineering analysis.

A draft EA will be issued and circulated for review by all interested parties. All timely filed comments on the draft EA will be analyzed by the staff and considered in the final EA. The staff's conclusions and recommendations will then be presented for consideration of the Commission in reaching its final licensing decision.

*Scoping Meetings:* Two scoping meetings will be conducted. The Public Scoping Meeting is on Tuesday, April 26, 1994, from 7 to 10 p.m.

*Location:* Lura B. Sharpe Elementary School, 7319 Lake Street, Pulaski, NY.

The Agency Scoping Meeting is on Wednesday, April 27, 1994, at 9:30 a.m. until noon.

*Location:* New York State Department of Environmental Conservation, 615 Erie Boulevard, West (Second Floor), Syracuse, NY 13204-2400.

Interested individuals, organizations, and agencies with environmental expertise are invited to attend either or both meetings and assist the staff in identifying the scope of environmental issues that should be analyzed in the EA.

To help focus discussions at the meetings, a scoping document outlining subject areas to be addressed in the EA was mailed to agencies and interested individuals on the Commission mailing list. Copies of the scoping document will also be available at the scoping meetings.

Persons choosing not to speak at the meetings, but who have views on issues or information relevant to the issues, may submit written statements for inclusion in the public record at the meeting. In addition, written comments



may be filed with the Secretary, Federal Energy Regulatory Commission, 825 North Capitol Street, NE., Washington, DC, 20426, by the deadline date shown in Item (k) above. All written correspondence should clearly show the following caption on the first page: Salmon River Hydroelectric Project, FERC No. 11408.

Intervenors—those on the Commission's service list for this proceeding (parties)—are reminded of the Commission's Rules of Practice and Procedure, requiring parties filing documents with the Commission, to serve a copy of the document on each person whose name appears on the official service list.

Further, if a party or interceder files comments or documents with the Commission relating to the merits of an issue that may affect the responsibilities of a particular resource agency, they must also serve a copy of the document on that resource agency.

*Site Visit:* A site visit to the Salmon River Hydroelectric Project is planned for April 26, 1994. Those who wish to attend should plan to meet at 8 a.m., at the Bennetts Bridge Powerhouse on County Route 22, Town of Orwell, NY. All participants are responsible for their own transportation. Bring a hard hat.

*m. Description of Project:* The proposed project consists of two developments progressing downstream of the Salmon River: Bennetts Bridge and Lighthouse Hill.

The Bennetts Bridge development consists of: (1) an existing dam 607 feet long and 45 feet high; (2) an existing reservoir 6 miles long; (3) an existing 10,000-foot-long conduit system; (4) an existing powerhouse containing four existing turbine-generator units with a total installed capacity of approximately 31,500 kilowatts (Kw); (5) three existing 12-kilovolt (Kv) electric transmission lines; and (6) appurtenant facilities.

The Lighthouse Hill development, located approximately 1 mile downstream of the Bennetts Bridge powerhouse, consists of: (1) an existing 382-foot-long concrete gravity dam; (2) an existing 4,300-foot-long reservoir; (3) three existing 17-foot-wide by 8-foot-high by 62-foot-long concrete penstocks; (4) an existing powerhouse containing two existing turbine-generator units with an installed capacity of 8,200 Kw (NIMO proposes to install a 2,150-Kw (nameplate rating) turbine-generator unit in the empty turbine bay in the Lighthouse Hill powerhouse; (5) an existing 400-foot-long, 12-Kv transmission line; and (6) appurtenant facilities. The average annual generation for both developments with the proposed new unit would increase from

108,000,000 to 113,246,000 kilowatt-hours. The owner of the project facilities is the Niagara Mohawk Power Corporation.

n. This notice also consists of the following standard paragraphs: D10.  
o. *Available Locations of Application:* A copy of the application, as amended and supplemented, is available for inspection and reproduction at the Commission's Public Reference and Files Maintenance Branch, located at 941 North Capitol Street NE, room 3104, Washington, DC 20426, or by calling (202) 208-1371. A copy is also available for inspection and reproduction at the applicant's office (see item (h) above).

#### Standard Paragraphs:

A2. *Development Application*—Any qualified applicant desiring to file a competing application must submit to the Commission, on or before the specified deadline date for the particular application, a competing development application, or a notice of intent to file such an application. Submission of a timely notice of intent allows an interested person to file the competing development application no later than 120 days after the specified deadline date for the particular application. Applications for preliminary permits will not be accepted in response to this notice.

A3. *Development Application*—Any qualified development applicant desiring to file a competing application must submit to the Commission, on or before the specified comment date for the particular application, a competing development application, or a notice of intent to file such an application. Submission of a timely notice of intent allows an interested person to file the competing development application no later than 120 days after the specified comment date for the particular application. Applications for preliminary permits will not be accepted in response to this notice.

A4. *Development Application*—Public notice of the filing of the initial development application, which has already been given, established the due date for filing competing applications or notices of intent. Under the Commission's regulations, any competing development application must be filed in response to and in compliance with public notice of the initial development application. No competing applications or notices of intent may be filed in response to this notice.

A5. *Preliminary Permit*—Anyone desiring to file a competing application for preliminary permit for a proposed project must submit the competing

application itself, or a notice of intent to file such an application, to the Commission on or before the specified comment date for the particular application (see 18 CFR 4.36). Submission of a timely notice of intent allows an interested person to file the competing preliminary permit application no later than 30 days after the specified comment date for the particular application. A competing preliminary permit application must conform with 18 CFR 4.30(b)(1) and (9) and 4.36.

A7. *Preliminary Permit*—Any qualified development applicant desiring to file a competing development application must submit to the Commission, on or before a specified comment date for the particular application, either a competing development application or a notice of intent to file such an application. Submission of a timely notice of intent to file a development application allows an interested person to file the competing application no later than 120 days after the specified comment date for the particular application. A competing license application must conform with 18 CFR 4.30(b)(1) and (9) and 4.36.

A9. *Notice of intent*—A notice of intent must specify the exact name, business address, and telephone number of the prospective applicant, and must include an unequivocal statement of intent to submit, if such an application may be filed, either a preliminary permit application or a development application (specify which type of application). A notice of intent must be served on the applicant(s) named in this public notice.

A10. *Proposed Scope of Studies under Permit*—A preliminary permit, if issued, does not authorize construction. The term of the proposed preliminary permit will be 36 months. The work proposed under the preliminary permit would include economic analysis, preparation of preliminary engineering plans, and a study of environmental impacts. Based on the results of these studies, the Applicant would decide whether to proceed with the preparation of a development application to construct and operate the project.

B. *Comments, Protests, or Motions to Intervene*—Anyone may submit comments, a protest, or a motion to intervene in accordance with the requirements of Rules of Practice and Procedure, 18 CFR 385.210, .211, .214. In determining the appropriate action to take, the Commission will consider all protests or other comments filed, but only those who file a motion to intervene in accordance with the

Commission's Rules may become a party to the proceeding. Any comments, protests, or motions to intervene must be received on or before the specified comment date for the particular application.

**B1. Protests or Motions to Intervene—** Anyone may submit a protest or a motion to intervene in accordance with the requirements of Rules of Practice and Procedure, 18 CFR 385.210, 385.211, and 385.214. In determining the appropriate action to take, the Commission will consider all protests filed, but only those who file a motion to intervene in accordance with the Commission's Rules may become a party to the proceeding. Any protests or motions to intervene must be received on or before the specified deadline date for the particular application.

**C. Filing and Service of Responsive Documents—** Any filings must bear in all capital letters the title "COMMENTS", "NOTICE OF INTENT TO FILE COMPETING APPLICATION", "COMPETING APPLICATION", "PROTEST", "MOTION TO INTERVENE", as applicable, and the Project Number of the particular application to which the filing refers. Any of the above-named documents must be filed by providing the original and the number of copies provided by the Commission's regulations to: The Secretary, Federal Energy Regulatory Commission, 825 North Capitol Street, NE., Washington, DC 20426. An additional copy must be sent to Director, Division of Project Review, Federal Energy Regulatory Commission, Room 1027, at the above-mentioned address. A copy of any notice of intent, competing application or motion to intervene must also be served upon each representative of the Applicant specified in the particular application.

**C1. Filing and Service of Responsive Documents—** Any filings must bear in all capital letters the title "COMMENTS", "RECOMMENDATIONS FOR TERMS AND CONDITIONS", "PROTEST", OR "MOTION TO INTERVENE", as applicable, and the Project Number of the particular application to which the filing refers. Any of the above-named documents must be filed by providing the original and the number of copies provided by the Commission's regulations to: The Secretary, Federal Energy Regulatory Commission, 825 North Capitol Street, NE., Washington, DC 20426. A copy of any motion to intervene must also be served upon each representative of the Applicant specified in the particular application.

**D2. Agency Comments—** Federal, state, and local agencies are invited to

file comments on the described application. A copy of the application may be obtained by agencies directly from the Applicant. If an agency does not file comments within the time specified for filing comments, it will be presumed to have no comments. One copy of an agency's must also be sent to the Applicant's representatives.

**D4. Filing and Service of Responsive Documents—** The application is ready for environmental analysis at this time, and the Commission is requesting comments, reply comments, recommendations, terms and conditions, and prescriptions.

The Commission directs, pursuant to section 4.34(b) of the regulations (see Order No. 533 issued May 8, 1991, 56 FR 23108, May 20, 1991) that all comments, recommendations, terms and conditions and prescriptions concerning the application be filed with the Commission within 60 days from the issuance date of this notice. (June 6, 1994 for Project No. 11433-000). All reply comments must be filed with the Commission within 105 days from the date of this notice. (July 20, 1994 for Project No. 11433-000).

Anyone may obtain an extension of time for these deadlines from the Commission only upon a showing of good cause or extraordinary circumstances in accordance with 18 CFR 385.2008.

All filings must (1) bear in all capital letters the title "PROTEST", "MOTION TO INTERVENE", "NOTICE OF INTENT TO FILE COMPETING APPLICATION," "COMPETING APPLICATION," "COMMENTS," "REPLY COMMENTS," "RECOMMENDATIONS," "TERMS AND CONDITIONS," or "PRESCRIPTIONS;" (2) set forth in the heading the name of the applicant and the project number of the application to which the filing responds; (3) furnish the name, address, and telephone number of the person protesting or intervening; and (4) otherwise comply with the requirements of 18 CFR 385.2001 through 385.2005. All comments, recommendations, terms and conditions or prescriptions must set forth their evidentiary basis and otherwise comply with the requirements of 18 CFR 4.34(b). Agencies may obtain copies of the application directly from the applicant. Any of these documents must be filed by providing the original and the number of copies required by the Commission's regulations to: The Secretary, Federal Energy Regulatory Commission, 825 North Capitol Street, NE., Washington, DC. 20426. An additional copy must be sent to Director, Division of Project Review,

Office of Hydropower Licensing, Federal Energy Regulatory Commission, Room 1027, at the above address. A copy of any protest or motion to intervene must be served upon each representative of the applicant specified in the particular application. A copy of all other filings in reference to this application must be accompanied by proof of service on all persons listed in the service list prepared by the Commission in this proceeding, in accordance with 18 CFR 4.34(b) and 385.2010.

**D9. Filing and Service of Responsive Documents—** The application is ready for environmental analysis at this time, and the Commission is requesting comments, reply comments, recommendations, terms and conditions, and prescriptions.

The Commission directs, pursuant to section 4.34(b) of the regulations (see Order No. 533 issued May 8, 1991, 56 FR 23108, May 20, 1991) that all comments, recommendations, terms and conditions and prescriptions concerning the application be filed with the Commission within 60 days from the issuance date of this notice. (June 6, 1994 for Project Nos. 2334-001 and 2290-006). All reply comments must be filed with the Commission within 105 days from the date of this notice. (July 20, 1994 for Project No. 2334-001 and July 19, 1994 for Project No. 2290-006).

Anyone may obtain an extension of time for these deadlines from the Commission only upon a showing of good cause or extraordinary circumstances in accordance with 18 CFR 385.2008.

All filings must (1) bear in all capital letters the title "COMMENTS", "REPLY COMMENTS", "RECOMMENDATIONS," "TERMS AND CONDITIONS," or "PRESCRIPTIONS;" (2) set forth in the heading the name of the applicant and the project number of the application to which the filing responds; (3) furnish the name, address, and telephone number of the person submitting the filing; and (4) otherwise comply with the requirements of 18 CFR 385.2001 through 385.2005. All comments, recommendations, terms and conditions or prescriptions must set forth their evidentiary basis and otherwise comply with the requirements of 18 CFR 4.34(b). Any of these documents must be filed by providing the original and the number of copies required by the Commission's regulations to: The Secretary, Federal Energy Regulatory Commission, 825 North Capitol Street, NE., Washington, DC 20426. An additional copy must be sent to Director, Division of Project Review,

Office of Hydropower Licensing, Federal Energy Regulatory Commission, Room 1027, at the above address. Each filing must be accompanied by proof of service on all persons listed on the service list prepared by the Commission in this proceeding, in accordance with 18 CFR 4.34(b), and 385.2010.

**D10. Filing and Service of Responsive Documents**—The application is ready for environmental analysis at this time, and the Commission is requesting comments, reply comments, recommendations, terms and conditions, and prescriptions.

The Commission directs, pursuant to section 4.34(b) of the regulations (see Order No. 533 issued May 8, 1991, 56 FR 23108, May 20, 1991) that all comments, recommendations, terms and conditions and prescriptions concerning the application be filed with the Commission within 60 days from the issuance date of this notice. (June 7, 1994 for Project No. 11408-000). All reply comments must be filed with the Commission within 105 days from the date of this notice. (July 22, 1994 for Project No. 11408-000).

Anyone may obtain an extension of time for these deadlines from the Commission only upon a showing of good cause or extraordinary circumstances in accordance with 18 CFR 385.2008.

All filings must (1) bear in all capital letters the title "COMMENTS", "REPLY COMMENTS", "RECOMMENDATIONS," "TERMS AND CONDITIONS," or "PRESCRIPTIONS;" (2) set forth in the heading the name of the applicant and the project number of the application to which the filing responds; (3) furnish the name, address, and telephone number of the person submitting the filing; and (4) otherwise comply with the requirements of 18 CFR 385.2001 through 385.2005. All comments, recommendations, terms and conditions or prescriptions must set forth their evidentiary basis and otherwise comply with the requirements of 18 CFR 4.34(b). Agencies may obtain copies of the application directly from the applicant. Any of these documents must be filed by providing the original and the number of copies required by the Commission's regulations to: The Secretary, Federal Energy Regulatory Commission, 825 North Capitol Street, NE., Washington, DC 20426. An additional copy must be sent to Director, Division of Project Review, Office of Hydropower Licensing, Federal Energy Regulatory Commission, room 1027, at the above address. Each filing must be accompanied by proof of service on all persons listed on the

service list prepared by the Commission in this proceeding, in accordance with 18 CFR 4.34(b), and 385.2010.

Dated: April 12, 1994, Washington, DC.

**Lois D. Cashell,**

*Secretary.*

[FR Doc. 94-9248 Filed 4-15-94; 8:45 am]

BILLING CODE 6717-01-P

[Docket No. CP94-331-000, et al.]

**K N Wattenberg Transmission Limited Liability Company, et al.; Natural Gas Certificate Filings**

April 11, 1994.

Take notice that the following filings have been made with the Commission:

**1. K N Wattenberg Transmission Limited Liability Co.**

[Docket No. CP94-331-000]

Take notice that on April 5, 1994, K N Wattenberg Transmission Limited Liability Company (K N Wattenberg), P.O. Box 281304, Lakewood, CO 80228-8304, filed in Docket No. CP94-331-000, a request pursuant to §§ 157.205 and 157.212 of the Commission's Regulations under the Natural Gas Act (18 CFR 157.205 and 157.212) for authorization to install and operate a new tap and valve setting in Weld County, Colorado for interruptible transportation service to Snyder Oil Corporation (Synder), under the blanket certificate issued in Docket No. CP92-203-000, pursuant to Section 7(c) of the Natural Gas Act, all as more fully set forth in the request which is on file with the Commission and open to public inspection.

K N Wattenberg proposes to install the new tap at its Hudson Compressor Station in Section 23, Township 2 North, Range 65 West in Weld County, Colorado, to be used as a delivery point under its existing April 1, 1993, interruptible transportation service agreement with Snyder. K N Wattenberg states that the volumes of gas delivered to Snyder at the proposed delivery point will be within Snyder's existing entitlement, with a projected peak day delivery of 71,000 MMBtu. K N Wattenberg estimates the cost of the facilities to be \$75,000. K N Wattenberg maintains the actual cost of the facilities will be reimbursed to it by Synder.

*Comment date:* May 26, 1994, in accordance with Standard Paragraph G at the end of this notice.

**2. Texas Gas Transmission Corp.**

[Docket No. CP94-334-000]

Take notice that on April 5, 1994, Texas Gas Transmission Corporation (Texas Gas), 3800 Frederica Street,

Owensboro, Kentucky 42301, filed in Docket No. CP94-334-000 a request pursuant to §§ 157.205 and 157.216 of the Commission's Regulations under the Natural Gas Act (18 CFR 157.205 and 157.216) for authorization under its blanket certificate issued in Docket No. CP82-407-000, to abandon facilities, all as more fully set forth in the request that is on file with the Commission and open to public inspection.

Texas Gas proposes to abandon by removal the Vandergrift sales tap located on the 10" Tie-Over Line in Tipton County, Tennessee, and the Westover sales tap located on the Ripley-Jackson 8" Line in Madison County, Tennessee.

Texas Gas states it has received letter requests from the Covington Gas Company, City of Covington, and the Jackson Utility Division, City of Jackson, to abandon service to the unnecessary Vandergrift and Westover sales taps since customers will be using the Covington and Jackson No. 3 existing taps, respectively. Texas Gas states that service to customers of Covington and Jackson will not be affected by these two abandonments.

The Vandergrift delivery point is an existing farm tap served by Covington and in turn served by Texas Gas under a Firm No Notice Transportation Agreement between Texas Gas and Covington dated November 1, 1993. The Westover delivery point is an existing tap served by Jackson and in turn served by Texas Gas under a Firm No Notice Transportation Agreement between Texas Gas and Jackson dated November 1, 1993.

*Comment date:* May 26, 1994, in accordance with Standard Paragraph G at the end of this notice.

**3. Mid Louisiana Gas Company**

[Docket No. CP94-336-000]

Take notice that on April 6, 1994, Mid Louisiana Gas Company (Mid La.), 333 Clay Street, suite 2700, Houston, Texas 77002 filed an application pursuant to Sections 7(b) and 7(c) of the Natural Gas Act for authorization to replace a portion of its mainline facility and a portion of its loop line facility in Adams County Mississippi. Mid La. also requests permission and approval to abandon the portions of line facilities that Mid La. is proposing to replace, all as more fully set forth in the application that is on file with the Commission and open to inspection.

Specifically, Mid La. is proposing to replace approximately 2,860 feet of its mainline facilities and approximately 4,350 feet of its looped line facilities, with approximately 2,820 feet of new mainline facilities and approximately

5,200 feet of new loop line facilities. It is stated that the length difference in the proposed replacement line facilities, is the result of Mid La.'s intent to re-route a portion of the replacement facilities approximately 1,000 feet east, so as to bypass a rural residential subdivision. Mid La. states that a portion of the existing line facilities, runs through the rural residential subdivision.

Mid La. estimates that the projected cost of this project will be approximately \$836,303, stating that the cost will be financed through current working capital funds.

*Comment date:* May 2, 1994, in accordance with Standard Paragraph F at the end of this notice.

#### 4. Tennessee Gas Pipeline Company

[Docket No. CP94-337-000]

Take notice that on April 6, 1994, Tennessee Gas Pipeline Company (Tennessee), P.O. Box 2511, Houston, Texas 77252-2511, filed in Docket No. CP94-337-000, an application pursuant to Section 7(b) of the Natural Gas Act for permission and approval to abandon a natural gas transportation service, all as more fully set forth in the application which is on file with the Commission and open to public inspection.

Tennessee states that it proposes to abandon the interruptible transportation service for Orange and Rockland Utilities, Inc. (Orange and Rockland) under Tennessee's Rate Schedule T-115. Tennessee further states that the agreement provides for Tennessee to receive up to 51,250 Dekatherms per day of natural gas from East Tennessee Natural Gas Company (East Tennessee) for transportation and delivery to Orange and Rockland. Tennessee says that East Tennessee and Orange and Rockland have both consented to abandonment of the above-described transportation service.

Tennessee states that it does not propose to abandon any facilities as a result of the proposed abandonment of service.

*Comment date:* May 2, 1994, in accordance with Standard Paragraph F at the end of this notice.

#### Standard Paragraphs:

F. Any person desiring to be heard or to make any protest with reference to said application should on or before the comment date, file with the Federal Energy Regulatory Commission, Washington, DC 20426, a motion to intervene or a protest in accordance with the requirements of the Commission's Rules of Practice and Procedure (18 CFR 385.214 or 385.211) and the Regulations under the Natural Gas Act (18 CFR 157.10). All protests

filed with the Commission will be considered by it in determining the appropriate action to be taken but will not serve to make the protestants parties to the proceeding. Any person wishing to become a party to a proceeding or to participate as a party in any hearing therein must file a motion to intervene in accordance with the Commission's Rules.

Take further notice that, pursuant to the authority contained in and subject to the jurisdiction conferred upon the Federal Energy Regulatory Commission by Sections 7 and 15 of the Natural Gas Act and the Commission's Rules of Practice and Procedure, a hearing will be held without further notice before the Commission or its designee on this application if no motion to intervene is filed within the time required herein, if the Commission on its own review of the matter finds that a grant of the certificate and/or permission and approval for the proposed abandonment are required by the public convenience and necessity. If a motion for leave to intervene is timely filed, or if the Commission on its own motion believes that a formal hearing is required, further notice of such hearing will be duly given.

Under the procedure herein provided for, unless otherwise advised, it will be unnecessary for applicant to appear or be represented at the hearing.

G. Any person or the Commission's staff may, within 45 days after issuance of the instant notice by the Commission, file pursuant to Rule 214 of the Commission's Procedural Rules (18 CFR 385.214) a motion to intervene or notice of intervention and pursuant to § 157.205 of the Regulations under the Natural Gas Act (18 CFR 157.205) a protest to the request. If no protest is filed within the time allowed therefor, the proposed activity shall be deemed to be authorized effective the day after the time allowed for filing a protest. If a protest is filed and not withdrawn within 30 days after the time allowed for filing a protest, the instant request shall be treated as an application for authorization pursuant to Section 7 of the Natural Gas Act.

Lois D. Cashell,

Secretary.

[FR Doc. 94-9247 Filed 4-15-94; 8:45 am]

BILLING CODE 6717-01-P

[Docket No. CP94-319-000, et al.]

#### TCP Gathering Co., et al.; Natural Gas Certificate Filings

April 8, 1994.

Take notice that the following filings have been made with the Commission:

##### 1. TCP Gathering Co.

[Docket No. CP94-319-000]

Take notice that on March 31, 1994, TCP Gathering Co. (Applicant) P.O. Box 281304, Lakewood, Colorado 80228, filed pursuant to Section 7(c) of the Natural Gas Act (NGA), and parts 157 and 284 of the Commission's Regulations for a certificate granting:

(1) a blanket certificate under Part 284, Subpart G authorizing applicant to provide open-access transportation service;

(2) a blanket certificate under Part 157, Subpart F authorizing certain construction and operation of certain facilities, sales arrangements and certain amendments and abandonments under NGA Section 7.

(3) a waiver of the subsequent reporting requirements under §§ 284.106(b) and 284.223(d)(2).

Applicant proposes to be a "transportation only" pipeline, transporting gas on an open-access basis on its system in Colorado and Utah. Applicant will provide both firm and interruptible transportation.

*Comment date:* April 29, 1994, in accordance with Standard Paragraph F at the end of this notice.

##### 2. Columbia Gas Transmission Corp.

[Docket No. CP94-320-000]

Take notice that on March 31, 1994, Columbia Gas Transmission Corporation (Columbia), 1700 MacCorkle Avenue, SE., Charleston, West Virginia 25314, filed in Docket No. CP94-320-000, an application pursuant to Section 7(c) of the Natural Gas Act for a certificate of public convenience and necessity authorizing the construction and operation of certain storage pipeline facilities, all as more fully set forth in the application which is on file with the Commission and open to public inspection.

Columbia states that to ensure reliable operation of its pipeline facilities, Columbia has initiated a program to install pig launching and receiving facilities in segments of its existing storage fields. Columbia further states that installing these facilities would result in the need to replace short segments of pipeline to provide for a uniform pipe size between launchers and receivers.

Columbia states that as a part of this program, Columbia proposes to

construct and operate about 3.2 miles of 10-, 12-, and 16-inch pipeline to replace about 3.2 miles of 6-, 8-, 10-, and 12-inch pipeline on its Lines SL-2149, SL-2482 and SL-2158 located in the Weaver Storage Field in Richland and Ashland Counties, Ohio. Columbia states that the estimated construction cost of these facilities is \$1,803,400.

Columbia states that it would also construct and operate three bidirectional launcher and receiver units and various appurtenant facilities. Columbia states that these facilities would be constructed under § 2.55(a) of the Commission's Regulations at an estimated cost of \$1,127,000.

*Comment date:* April 29, 1994, in accordance with Standard Paragraph F at the end of this notice.

### 3. Williams Natural Gas Company

[Docket No. CP94-338-000]

Take notice that on April 6, 1994, Williams Natural Gas Company (WNG), P.O. Box 3288, Tulsa, Oklahoma 74101, filed in Docket No. CP94-338-000 a request pursuant to §§ 157.205 and 157.212 of the Commission's Regulations under the Natural Gas Act (18 CFR 157.205 and 157.212) for authorization to install a tap, measuring, regulating and appurtenant facilities to deliver transportation gas to Mercado Gas Services (Mercado) in Texas County, Oklahoma, under WGN's blanket certificate issued in Docket No. CP82-479-000 pursuant to Section 7 of the Natural Gas Act, all as more fully set forth in the request which is on file with the Commission and open to public inspection.

Specifically, WNG seeks authorization to install a 2-inch tap on the Guymon-Blackwell 26-inch pipeline and construct measuring, regulating and appurtenant facilities in the Northwest Quarter (NW/4) of Section 28, Township 5 North, Range 16 ECM, Texas County, Oklahoma.

WNG says that the gas delivered by WNG to Mercado would be used in a hog processing plant. WNG states that the annual volume delivered is estimated to be approximately 31,400 Dth the first year and would remain constant over the next five years. WNG submits that the peak day volume is estimated to be 400 Dth and would also remain constant for five years. WNG states that the total volume to be delivered to Mercado would not exceed the total volume authorized prior to this request. WNG further states that this change is not prohibited by an existing tariff and it has sufficient capacity to accomplish the deliveries specified without detriment or disadvantage to its other customers. WNG says that the

estimated cost of construction is \$19,790, which would be reimbursed by Mercado. WNG indicates that Mercado would also reimburse WNG for associated income taxes.

*Comment date:* May 23, 1994, in accordance with Standard Paragraph G at the end of this notice.

### Standard Paragraphs

F. Any person desiring to be heard or to make any protest with reference to said application should on or before the comment date, file with the Federal Energy Regulatory Commission, Washington, DC 20426, a motion to intervene or a protest in accordance with the requirements of the Commission's Rules of Practice and Procedure (18 CFR 385.214 or 385.211) and the Regulations under the Natural Gas Act (18 CFR 157.10). All protests filed with the Commission will be considered by it in determining the appropriate action to be taken but will not serve to make the protestants parties to the proceeding. Any person wishing to become a party to a proceeding or to participate as a party in any hearing therein must file a motion to intervene in accordance with the Commission's Rules.

Take further notice that, pursuant to the authority contained in and subject to the jurisdiction conferred upon the Federal Energy Regulatory Commission by Sections 7 and 15 of the Natural Gas Act and the Commission's Rules of Practice and Procedure, a hearing will be held without further notice before the Commission or its designee on this application if no motion to intervene is filed within the time required herein, if the Commission on its own review of the matter finds that a grant of the certificate and/or permission and approval for the proposed abandonment are required by the public convenience and necessity. If a motion for leave to intervene is timely filed, or if the Commission on its own motion believes that a formal hearing is required, further notice of such hearing will be duly given.

Under the procedure herein provided for, unless otherwise advised, it will be unnecessary for applicant to appear or be represented at the hearing.

G. Any person or the Commission's staff may, within 45 days after issuance of the instant notice by the Commission, file pursuant to Rule 214 of the Commission's Procedural Rules (18 CFR 385.214) a motion to intervene or notice of intervention and pursuant to § 157.205 of the Regulations under the Natural Gas Act (18 CFR 157.205) a protest to the request. If no protest is filed within the time allowed therefor,

the proposed activity shall be deemed to be authorized effective the day after the time allowed for filing a protest. If a protest is filed and not withdrawn within 30 days after the time allowed for filing a protest, the instant request shall be treated as an application for authorization pursuant to Section 7 of the Natural Gas Act.

Lois D. Cashell,

Secretary.

[FR Doc. 94-9246 Filed 4-15-94; 8:45 am]

BILLING CODE 6717-01-P

[Docket No. RP94-43-004]

### ANR Pipeline Co.; Proposed Changes in FERC Gas Tariff

April 12, 1994.

Take notice that on April 7, 1994, ANR Pipeline Company (ANR), tendered for filing as part of its FERC Gas Tariff, revised tariff sheets listed on Attachment A to the filing, to its Second Revised Volume No. 1 and Original Volume No. 2, which ANR proposes to be effective May 1, 1994.

ANR states that the revised tariff sheets are being submitted in compliance with the Commission's "Order Granting and Denying Summary Disposition and Establishing Hearing Procedures," issued March 23, 1994, in the captioned proceeding.

ANR states that each of its Volume Nos. 1 and 2 customers, interested State Commissions and all parties on the Commission's service list have been apprised of this filing via U.S. Mail.

Any person desiring to protest said filing should file a protest with the Federal Energy Regulatory Commission, 825 North Capitol Street, NE., Washington, DC 20426 in accordance with Rule 211 of the Commission's Rules of Practice and Procedure (18 CFR 385.211). All such protests should be filed on or before April 19, 1994. Protests will be considered by the Commission in determining the appropriate action to be taken, but will not serve to make protestants parties to the proceeding. Copies of this application are on file with the Commission and are available for public inspection.

Lois D. Cashell,

Secretary.

[FR Doc. 94-9206 Filed 4-15-94; 8:45 am]

BILLING CODE 6717-01-M

[Docket No. ER94-1127-000]

**Entergy Services, Inc.; Filing**

April 11, 1994.

Take notice that Entergy Services, Inc. (Entergy Services), acting as agent for Arkansas Power & Light Company, Gulf States Utilities Company, Louisiana Power & Light Company, Mississippi Power & Light Company, and New Orleans Public Service Inc. (collectively the Entergy Operating Companies), on April 1, 1994, tendered for filing a limited firm service schedule that will supplement and be made part of the Interchange Agreement between Mississippi Power & Light Company and South Mississippi Electric Power Association (SMEPA), and two letter agreements for the sale of limited firm capacity and energy to SMEPA. Entergy Services requests an effective date of June 1, 1994.

Any person desiring to be heard or to protest said filing should file a motion to intervene or protest with the Federal Energy Regulatory Commission, 825 North Capitol Street, NE., Washington, DC 20426, in accordance with Rules 211 and 214 of the Commission's Rules of Practice and Procedure (18 CFR 385.211 and 18 CFR 385.214). All such motions or protests should be filed on or before April 25, 1994. Protests will be considered by the Commission in determining the appropriate action to be taken, but will not serve to make protestants parties to the proceeding. Any person wishing to become a party must file a motion to intervene. Copies of this filing are on file with the Commission and are available for public inspection.

Lois D. Cashell,  
Secretary.

[FR Doc. 94-9209 Filed 4-15-94; 8:45 am]

BILLING CODE 6717-01-M

[Docket No. RP94-143-001]

**National Fuel Gas Supply Corp.; Compliance Filing**

April 12, 1994.

Take notice that on April 7, 1994, National Fuel Gas Supply Corporation (National) tendered for filing in accordance with the Commission's Letter Order issued March 14, 1994, Third Revised Sheet No. 225 to reflect the correct dates regarding the filing of its report on the final balances.

National further states that copies of this filing were served upon the company's jurisdictional customers and the Regulatory Commission's of the States of New York, Ohio, Pennsylvania,

Delaware, Massachusetts, and New Jersey.

Any person desiring to protest said filing should file a protest with the Federal Energy Regulatory Commission, 825 North Capitol Street, NE., Washington, DC 20426, in accordance with Rule 211 of the Commission's Rules of Practice and Procedure (18 CFR 385.211). All such protests should be filed on or before April 19, 1994. Protests will be considered by the Commission in determining the appropriate action to be taken but will not serve to make protestants parties to the proceeding. Copies of this filing are on file with the Commission and are available for public inspection.

Lois D. Cashell,

Secretary.

[FR Doc. 94-9207 Filed 4-15-94; 8:45 am]

BILLING CODE 6717-01-M

[Docket No. RP94-186-001]

**Questar Pipeline Co.; Tariff Filing**

April 12, 1994.

Take notice that on April 8, 1994, as follow-up to Questar Pipeline Company's March 24, 1994, filing in Docket No. RP94-186-000, Questar tendered for filing and acceptance to become effective April 1, 1994, Substitute First Revised Sheet No. 5A.1 to First Revised Volume No. 1 of its FERC Gas Tariff.

Questar states that this tariff sheet implements a mechanism that allows Questar to pass through to Mountain Fuel Supply Company \$13,387 in take-or-pay buyout/buydown costs that were assigned to Questar by Colorado Interstate Gas Company in Docket Nos. RP94-85-000 and RP94-130-000.

Questar states that copies of this filing were served upon Mountain Fuel Supply Company, Colorado Interstate Gas Company and the Public Service Commissions of Utah and Wyoming.

Any person desiring to protest said filing should file a protest with the Federal Energy Regulatory Commission, 825 North Capitol Street, NE., Washington, DC 20426, in accordance with Rule 211 of the Commission's Rules of Practice and Procedure (18 CFR 385.211). All such protests should be filed on or before April 19, 1994. Protests will be considered by the Commission in determining the appropriate action to be taken, but will not serve to make protestants parties to the proceeding. Copies of this filing are

on file with the Commission and are available for public inspection.

Lois D. Cashell,

Secretary.

[FR Doc. 94-9210 Filed 4-15-94; 8:45 am]

BILLING CODE 6717-01-M

[Docket No. RP94-205-000]

**Williams Natural Gas Co.; Proposed Changes in FERC Gas Tariff**

April 12, 1994.

Take notice that on April 8, 1994, Williams Natural Gas Company (WNG) tendered for filing as part of its FERC Gas Tariff, Second Revised Volume No. 1, First Revised Sheet No. 250. The proposed effective date of this tariff sheet is May 8, 1994.

WNG states that this filing is being made to modify Article 13 of the General Terms and Conditions to provide that WNG will file revised fuel and loss reimbursement percentages by December 1 of each year based on actual experience for the 12-month period ended the previous September 30. Such revised fuel and loss reimbursement percentages would be effective on January 1 of each year. This would result in revised fuel and loss reimbursement percentages being made effective on January 1, 1995, based on the first 12 months of restructured operations.

WNG states that a copy of its filing was served on all jurisdictional customers and interested state commissions.

Any person desiring to be heard or to protest said filing should file a motion to intervene or a protest with the Federal Energy Regulatory Commission, 825 North Capitol Street, NE., Washington, DC 20426, in accordance with §§ 385.214 and 385.211 of the Commission's Rules and Regulations. All such motions or protests should be filed on or before April 19, 1994. Protests will be considered by the Commission in determining the appropriate action to be taken, but will not serve to make protestants parties to the proceeding. Any person wishing to become a party must file a motion to intervene. Copies of this filing are on file with the Commission and are available for public inspection in the public reference room.

Lois D. Cashell,

Secretary.

[FR Doc. 94-9208 Filed 4-15-94; 8:45 am]

BILLING CODE 6717-01-M

**Office of Hearings and Appeals****Cases Filed During the Week of February 25 Through March 4, 1994**

During the Week of February 25 through March 4, 1994, the appeals and applications for exception or other relief listed in the Appendix to this Notice were filed with the Office of Hearings and Appeals of the Department of

Energy. Submissions inadvertently omitted from earlier lists have also been included.

Under DOE procedural regulations, 10 CFR Part 205, any person who will be aggrieved by the DOE action sought in these cases may file written comments on the application within ten days of service of notice, as prescribed in the procedural regulations. For purposes of the regulations, the date of service of

notice is deemed to be the date of publication of this Notice or the date of receipt by an aggrieved person of actual notice, whichever occurs first. All such comments shall be filed with the Office of Hearings and Appeals, Department of Energy, Washington, DC 20585.

Dated: April 7, 1994.

**Richard W. Dugan,**  
Acting Director, Office of Hearings and Appeals.

**LIST OF CASES RECEIVED BY THE OFFICE OF HEARINGS AND APPEALS**

[Week of February 25 through March 4, 1994]

Date	Name and location of applicant	Case No.	Type of submission
Feb. 25, 1994 ..	Oxy USA, Inc., Washington, DC .....	LFA-0359	Appeal of an information request denial. If granted: Oxy USA, Inc. would receive access to the October 1, 1979 to January 1981 Audit Report by the Economic Regulatory Administration.
Feb. 28, 1994 ..	H.C. Petroleum, Inc., Warwick, RI .....	LEE-0094	Exception to the reporting requirements. If granted: H.C. Petroleum, Inc. would not be required to file Form EIA-782B, "Resellers/Retailers' Monthly Petroleum Product Sales Report."
Feb. 28, 1994 ..	Raymer Oil Company, Statesville, NC .....	LEE-0095	Exception to the reporting requirements. If granted: Raymer Oil Company would not be required to file Form EIA-782B, "Resellers/Retailers' Monthly Petroleum Product Sales Report."
Feb. 28, 1994 ..	Storey Oil Company, Inc., Washington, DC .....	LCX-0012	Motion for remand. If granted: The amount of money that Storey Oil Company, Inc. must remit to the DOE pursuant to the June 24, 1987 Remedial Order issued by Office of Hearings and Appeals would be reconsidered in light of the remand decision by the Federal Energy Regulatory Commission.
Mar. 1, 1994 ....	Texaco/Tom's Texaco, Danbury, CT .....	RR321-153	Request for modification/rescission in the Texaco Refund Proceeding. If granted: The July 23, 1993 Decision and Order (Case No. RF321-18730) issued to Tom's Texaco would be modified regarding the firm's Application for Refund submitted in the Texaco refund proceeding.
Mar. 2, 1994 ....	Cowles Publishing Company, Spokane, WA .....	LFA-0360	Appeal of an information request denial. If granted: The February 2, 1994 Freedom of Information Denial issued by the Richland Field Office would be rescinded, and Cowles Publishing Company would receive access to a document entitled, "Voluntary and Planned Human Exposure," and documents concerning pre-1963 experiments conducted on human subjects at DOE's Hanford, Washington facility.
Mar. 3, 1994 ....	Visa Petroleum, Inc., Fresno, CA .....	LEE-0096	Exception to the reporting requirements. If granted: Visa Petroleum, Inc. would not be required to file Form EIA-782B, "Resellers/Retailers' Monthly Petroleum Product Sales Report."

**REFUND APPLICATIONS RECEIVED**

[Week of February 25 to March 4, 1994]

Date received	Name of refund applicant	Case No.
2/25/94 thru 3/4/94 .....	Texaco refund, applications received .....	RF321-20308 thru RF321-20939.
2/28/94 .....	Ingram Readymix, Inc. ....	RF321-95139.
2/28/94 .....	Chemstone Corporation .....	RF272-95140.
2/28/94 .....	Augusta Mental Institute .....	RF300-21774.
2/28/94 .....	M.M. Smith Storage Warehouse .....	RF272-95133.
2/28/94 .....	Lincoln Land Moving & Storage .....	RF272-95134.
2/28/94 .....	Averitt Express .....	RF272-95135.
2/28/94 .....	Russell Trucking Line, Inc. ....	RF272-95136.
2/28/94 .....	Farmers Union Co-op Oil Co. ....	RF272-95137.
2/28/94 .....	Double Circle Cooperative .....	RF272-95138.
3/3/94 .....	Sullivan County Central Receiving .....	RF272-95142.
3/4/94 .....	Rainbow Cab Co. ....	RC272-229.
3/4/94 .....	Mitchell Welding Supply Co. ....	RC272-230.
3/4/94 .....	Covil Insulating Co. ....	RC272-231.

REFUND APPLICATIONS RECEIVED—Continued  
[Week of February 25 to March 4, 1994]

Date received	Name of refund applicant	Case No.
3/8/94 .....	St. Benedict's Hearth Corp. ....	RC272-232.
3/8/94 .....	Dan Branch Mining Co., Inc. ....	RC272-233.

[FR Doc. 94-9279 Filed 4-15-94; 8:45 am]  
BILLING CODE 6450-01-P

### ENVIRONMENTAL PROTECTION AGENCY

[FRL-4862-7]

#### Agency Information Collection Activities Under OMB Review

AGENCY: Environmental Protection Agency (EPA).

ACTION: Notice.

**SUMMARY:** In compliance with the Paperwork Reduction Act (PRA) (44 U.S.C. 3501 *et seq.*), this notice announces the Office of Management and Budget's (OMB) responses to Agency PRA clearance requests.

**FOR FURTHER INFORMATION CONTACT:** Sandy Farmer (202) 260-2740.

#### SUPPLEMENTARY INFORMATION:

##### OMB Responses to Agency PRA Clearance Requests

EPA ICR No. 0270.30; Public Water Supply Program; was approved 03/30/94; OMB No. 2040-0090; expires 03/31/97. In addition to the approval of the 1990 base ICR renewal (0270.25, OMB No. 2040-0090; this ICR also includes reporting and recordkeeping requirements identified under the following previously separate information collections: 0270.24 Monitoring for Phase II Synthetic Organic and Inorganic Chemicals, OMB No. 2040-0090; 0270.26 Monitoring for Lead and Copper, OMB No. 2040-0090; 0270.27 Monitoring for Eight VOCs, and MCLGs for Aldicarb, Aldicarb Sulfoxide, Aldicarb Sulfone, Pentachlorophenol, and Barium, OMB No. 2040-0090; 0270.29 Monitoring for Phase V Synthetic Organic and Inorganic Chemicals, OMB No. 2040-0155.

EPA ICR No. 1591.03; Standards for Reformulated Gasoline; was approved 03/18/94; OMB No. 2060-0277; expires 03/31/97.

EPA ICR No. 1668.01; Oil Pollution Prevention National Survey; was approved 03/24/94; OMB No. 2050-0134; expires 03/31/95.

EPA ICR No. 1550.03; Conflict of Interest in EPAAR (Environmental

Protection Agency Regulations); was approved 03/29/94; OMB No. 2030-0023; expires 03/31/97.

EPA ICR No. 1038.07; Invitation for Bids (IFB) and Request for Proposals (RFP); was approved 03/25/94; OMB No. 2030-0006; expires 03/31/97.

EPA ICR No. 1432.14; Recordkeeping and Periodic Reporting of the Production, Import, Export, Feedstock Use and Destruction of Ozone-Depletion Substances; was approved 03/14/94; OMB No. 2060-0170; expires 09/30/96.

#### OMB Disapproval

EPA ICR No. 1550.02, Conflict of interest in EPAAR (Environmental Protection Agency Regulations); was withdrawn at the request of the Agency.

Dated: April 8, 1994.

Paul Lapsley,

Director, Regulatory Management Division.

[FR Doc. 94-9289 Filed 4-15-94; 8:45 am]

BILLING CODE 6560-50-F

[FRL-4863-2]

#### Agency Information Collection Activities Under OMB Review

AGENCY: Environmental Protection Agency (EPA).

ACTION: Notice.

**SUMMARY:** In compliance with the Paperwork Reduction Act (44 U.S.C. 3501 *et seq.*), this notice announces that the Information Collection Request (ICR) abstracted below has been forwarded to the Office of Management and Budget (OMB) for review and comment. The ICR describes the nature of the information collection and its expected cost and burden.

**DATES:** Comments must be submitted on or before May 18, 1994.

**FOR FURTHER INFORMATION CONTACT:** For further information, or to obtain a copy of the ICR, contact Sandy Farmer at EPA, (202) 260-2740.

#### SUPPLEMENTARY INFORMATION:

##### Office of Research and Development

*Title:* Laboratory Performance Evaluation Studies for Water Analyses (EPA No. 0234.05; OMB No. 2080-0021). This ICR requests an extension to an existing information collection.

**Abstract:** Pursuant to the Safe Drinking Water Act (Public Law 93-523) 40 CFR parts 141 through 142, and the Federal Water Pollution Control Act Amendments of 1972 (Public Law 92-500), the EPA's Environmental Monitoring Systems Laboratory (EMSL-CIN) must conduct performance evaluation (PE) studies on laboratories that routinely analyze several types of water samples. There are three types of PE studies that are conducted:

(1) Water Pollution (WP) Studies, which provide EPA with information on laboratories producing critical data for regulatory purposes, and to support the wastewater certification programs administered by many States;

(2) Discharge Monitoring Report-Quality Assurance (DMR-QA) Studies, which provide EPA with an objective estimate of the analytical capability of laboratories performing self-monitoring analyses, as required in major National Pollutant Discharge Elimination System (NPDES) permits; and

(3) Water Supply (WS) Studies, which support the drinking water laboratory certification program administered by the States.

On a routine basis, EMSL-CIN will distribute samples containing concentrations of chemical that are unknown to the receiving laboratory. The laboratory analyzes the samples and reports their results by completing the appropriate EPA form and returning it to EMSL-CIN for evaluation. EMSL-CIN sends each laboratory a copy of their performance evaluation that includes the data they submitted to EMSL-CIN, the true values of the related study and PE limits, and an evaluation for each reported value.

The results are used by EPA, State, and private laboratory personnel to identify and correct analytical deficiencies of laboratories, thereby improving the data quality of their monitoring operations. WP and WS study results can be decisive in the laboratory certification process, and DMR-QA study results are used to target NPDES laboratories with apparent analytical problems for on-site inspection by EPA or State regulatory personnel.

**Burden Statement:** Public reporting burden for this collection of information is estimated to average 8 hours per



response including the time for reviewing instructions, searching existing information sources, and completing and reviewing the collection of information.

**Respondents:** Businesses or other for-profit organizations, non-profit institutions, small businesses or organizations, State and local organizations.

**Estimated Number of Respondents:** 17,700.

**Estimated Number of Responses per Respondent:** 1.

**Frequency of Collection:** Semiannually for WP and WS Studies, annually for DMR-QA Studies.

**Estimated Total Annual Burden on Respondents:** 141,550.

Send comments regarding the burden estimate, or any other aspect of this collection of information, including suggestions for reducing the burden, to: Sandy Farmer, U.S. Environmental Protection Agency, Information Policy Branch (2136), 401 M Street, SW., Washington, DC 20460.

and  
Tim Hunt, Office of Management and Budget, Office of Information and Regulatory Affairs, 725 17th Street, NW., Washington, DC 20530.

Dated: April 8, 1994.

Paul Lapsley,  
Director, Regulatory Management Division.  
[FR Doc. 94-9298 Filed 4-15-94; 8:45 am]

BILLING CODE 6560-50-F

[FRL-4875-3]

**Information Resources Management Strategic Planning Task Force of the National Advisory Council for Environmental Policy and Technology; Public Meeting**

**AGENCY:** Environmental Protection Agency (EPA).

**ACTION:** Notice of public meeting.

**SUMMARY:** Under the Federal Advisory Committee Act, Public Law 92463, EPA gives notice of a one-day meeting of the Information Resources Management (IRM) Strategic Planning Task Force. The IRM Task Force is a special task force formed under the Environmental Information and Assessment (EIA) Committee, which is one of the standing committees of the National Advisory Council for Environmental Policy and Technology (NACEPT). NACEPT provides advice and recommendations to the Administrator of EPA on a broad range of environmental policy issues, and the EIA Committee examines issues associated with the gathering,

dissemination, and use of environmentally related data and information.

The IRM Task Force was formed to provide recommendations on key elements that EPA should include in an Information Resources Management Strategic Plan for the Agency. The meeting is being held to discuss the comments the Task Force has received on its Interim Recommendations.

Scheduling constraints preclude oral comments from the public during the meeting. Written comments can be submitted by mail, and will be transmitted to Task Force members for consideration.

**DATES:** The public meeting will be held on Thursday, May 12, 1994, from 9 a.m. to 5 p.m. in room 283 at the National Governors' Association Hall of the States, 444 North Capitol Street, Washington, DC.

**ADDRESSES:** Written comments should be sent to:

Mark Joyce, 1601F, Office of Cooperative Environmental Management, U.S. EPA, 401 M Street SW., Washington, DC 20460.

**FOR FURTHER INFORMATION CONTACT:** Mark Joyce, Designated Federal Official, Direct line (202) 260-6889, Secretary's line (202) 260-6892.

Dated: April 11, 1994.

Mark Joyce,  
Designated Federal Official.

[FR Doc. 94-9294 Filed 4-15-94; 8:45 am]

BILLING CODE 6560-50-M

[OPPTS-51828; FRL-4772-8]

**Certain Chemicals; Premanufacture Notices**

**AGENCY:** Environmental Protection Agency (EPA).

**ACTION:** Notice.

**SUMMARY:** Section 5(a)(1) of the Toxic Substances Control Act (TSCA) requires any person who intends to manufacture or import a new chemical substance to submit a premanufacture notice (PMN) to EPA at least 90 days before manufacture or import commences. Statutory requirements for section 5(a)(1) premanufacture notices are discussed in the final rule published in the *Federal Register* of May 13, 1983 (48 FR 21722). This notice announces receipt of 116 such PMNs and provides a summary of each.

**DATES:** Close of review periods:

P 93-1624, December 7, 1993.

P 93-1625, 93-1626, 93-1627, December 8, 1993.

P 93-1628, 93-1629, 93-1630, 93-1631, December 11, 1993.

P 93-1632, 93-1633, 93-1634, 93-1635, 93-1636, 93-1637, 93-1638, December 12, 1993.

P 93-1639, 93-1640, 93-1641, 93-1642, 93-1643, 93-1644, 93-1645, 93-1646, December 13, 1993.

P 93-1647, December 18, 1993.

P 93-1648, 93-1649, December 13, 1993.

P 93-1650, December 15, 1993.

P 93-1651, 93-1652, 93-1653, December 18, 1993.

P 93-1654, 93-1655, 93-1656, 93-1657, 93-1658, 93-1659, 93-1660, December 19, 1993.

P 93-1661, 93-1662, 93-1663, 93-1664, December 20, 1993.

P 93-1665, 93-1666, December 21, 1993.

P 93-1667, December 22, 1993.

P 93-1668, 93-1669, 93-1670, 93-1671, 93-1672, 93-1673, December 25, 1993.

P 93-1674, 93-1675, 93-1676, 93-1677, 93-1678, 93-1679, 93-1680, 93-1681, 93-1682, 93-1683, 93-1684, 93-1685, 93-1686, 93-1687, 93-1688, December 26, 1993.

P 93-1689, December 25, 1993.

P 93-1690, 93-1691, 93-1692, 93-1693, 93-1694, December 26, 1993.

P 93-1695, 93-1696, 93-1697, 93-1698, 93-1699, 93-1700, 93-1701, 93-1702, 93-1703, 93-1704, 93-1705, 93-1706, 93-1707, 93-1708, 93-1709, 93-1710, 93-1711, 93-1712, 93-1713, 93-1714, 93-1715, 93-1716, 93-1717, 93-1718, 93-1719, 93-1720, 93-1721, 93-1722, 93-1723, 93-1724, 93-1725, 93-1726, 93-1727, 93-1728, 93-1729, 93-1730, 93-1731, 93-1732, 93-1733, 93-1734, December 27, 1993.

P 93-1735, 93-1736, 93-1737, 93-1738, 93-1739, December 28, 1993.

Written comments by:

P 93-1624, November 7, 1993.

P 93-1625, 93-1626, 93-1627, 93-1628, November 8, 1993.

P 93-1629, 93-1630, 93-1631, November 11, 1993.

P 93-1632, 93-1633, 93-1634, 93-1635, 93-1636, 93-1637, 93-1638, November 12, 1993.

P 93-1639, 93-1640, 93-1641, 93-1642, 93-1643, 93-1644, 93-1645, 93-1646, November 13, 1993.

P 93-1647, November 18, 1993.

P 93-1648, 93-1649, November 13, 1993.

P 93-1650, 93-1651, November 15, 1993.

P 93-1652, 93-1653, November 18, 1993.

P 93-1654, 93-1655, 93-1656, 93-1657, 93-1658, 93-1659, 93-1660, November 19, 1993.

P 93-1661, 93-1662, 93-1663, 93-1664, November 20, 1993.

P 93-1665, 93-1666, November 21, 1993.

P 93-1667, November 22, 1993.

P 93-1668, 93-1669, 93-1670, 93-1681, 93-1672, 93-1673, November 25, 1993.

P 93-1674, 93-1675, 93-1676, 93-1677, 93-1678, 93-1679, 93-1680, 93-1681, 93-1682, 93-1683, 93-1684, 93-1685, 93-1686, 93-1687, 93-1688, November 26, 1993.

P 93-1689, November 25, 1993.

P 93-1690, 93-1691, 93-1692, 93-1693, 93-1694, November 26, 1993.

P 93-1695, 93-1696, 93-1697, 93-1698, 93-1699, 93-1700, 93-1701, 93-1702, 93-1703, 93-1704, 93-1705, 93-1706, 93-1707, 93-1708, 93-1709, 93-1710, 93-1711, 93-1712, 93-1713, 93-1714, 93-1715, 93-1716, 93-1717, 93-1718, 93-1719, 93-1720, 93-1721, 93-1722, 93-1723, 93-1724, 93-1725, 93-1726, 93-1727, 93-1728, 93-1729, 93-1730, 93-1731, 93-1732, 93-1733, November 27, 1993.

P 93-1734, 93-1735, 93-1736, 93-1737, 93-1738, 93-1739, November 28, 1993.

**ADDRESSES:** Written comments, identified by the document control number "[OPPTS-51828]" and the specific PMN number should be sent to: Document Control Office (7407), Office of Pollution Prevention and Toxics, Environmental Protection Agency, 401 M St., SW., Rm. ETG-099 Washington, DC 20460 (202) 260-1532.

**FOR FURTHER INFORMATION CONTACT:** Susan B. Hazen, Director, Environmental Assistance Division (7408), Office of Pollution Prevention and Toxics, Environmental Protection Agency, Rm. E-545, 401 M St., SW., Washington, DC, 20460 (202) 554-1404, TDD (202) 554-0551.

**SUPPLEMENTARY INFORMATION:** The following notice contains information extracted from the nonconfidential version of the submission provided by the manufacturer on the PMNs received by EPA. The complete nonconfidential document is available in the TSCA Nonconfidential Information Center (NCIC), ETG-102 at the above address between 12 noon and 4 p.m., Monday through Friday, excluding legal holidays.

P 93-1624

**Importer.** Pumex U. S. A., Inc.  
**Chemical.** (G) Aromatic polyester polyol.

**Use/Production.** (S) Formulate of urethane systems for rigid form and elastomer application. Import range: 50,000-200,000 kg/yr.

P 93-1625

**Manufacturer.** Hardwicke Chemical Inc.

**Chemical.** (S) 4-Fluoro-3-bromobenzaldehyde.

**Use/Production.** (S) Organic chemical intermediate. Prod. range: 30,000-300,000 kg/yr.

P 93-1626

**Manufacturer.** Hardwicke Chemical Inc.

**Chemical.** (S) 4-Fluoro-3-bromobenzaldehyde acetal.

**Use/Production.** (S) Organic chemical intermediate. Prod. range: 35,000-350,000 kg/yr.

P 93-1627

**Manufacturer.** Hardwicke Chemical Inc.

**Chemical.** (S) 4-Fluoro-3-phenoxybenzaldehyde acetal.

**Use/Production.** (S) Organic chemical intermediate. Prod. range: 25,000-250,000 kg/yr.

P 93-1628

**Manufacturer.** Hardwicke Chemical Inc.

**Chemical.** (S) 4-Fluoro-3-phenoxybenzaldehyde.

**Use/Production.** (S) Agricultural intermediate (used for manufacture of baythriod). Prod. range: 20,000-200,000 kg/yr.

P 93-1629

**Manufacturer.** Confidential.

**Chemical.** (G) Modified polymer of styrene and aliphatic maleate.

**Use/Production.** (G) Component of spray applied coating. Prod. range: 5,000-11,000 kg/yr.

P 93-1630

**Manufacturer.** Amoco Corporation.

**Chemical.** (G) Polyolefin-modified polyphthalamide.

**Use/Production.** (S) Engineering polymers for use in the manufacture of articles. Prod. range: Confidential.

P 93-1631

**Importer.** Confidential.

**Chemical.** (G) Azo chromium complex dyestuff.

**Use/Import.** (G) Open, non-dispersive. Import range: Confidential.

P 93-1632

**Importer.** DMS Resins U. S., Inc.

**Chemical.** (G) Dibasic acid/glycol ester.

**Use/Import.** (G) Used as a raw material in the production of powdered paint. Import range: Confidential.

P 93-1633

**Manufacturer.** Confidential.

**Chemical.** (G) Polyurethane polycarbodimide polymer.

**Use/Production.** (G) Paint. Prod. range: Confidential.

P 93-1634

**Manufacturer.** Confidential.

**Chemical.** (G) Polyurethane polycarbodimide polymer.

**Use/Production.** (G) Paint. Prod. range: Confidential.

P 93-1635

**Manufacturer.** Confidential.

**Chemical.** (G) Polyurethane polycarbodimide polymer.

**Use/Production.** (G) Paint. Prod. range: Confidential.

P 93-1636

**Importer.** Huls America Inc.

**Chemical.** (S) Castor oil, ethoxylated, dioleate.

**Use/Import.** (S) Emulsion concentration for metal working fluids. Import range: 10,000-30,000 kg/yr.

P 93-1637

**Manufacturer.** Confidential.

**Chemical.** (G) Mixture of reaction products of diphenylmethane diisocyanate polymer; oxirane, methyl- polymer with oxirane; and hexanedioic acid, polymer with 1,2-propanediol.

**Use/Production.** (S) Graphic arts printing plate. Prod. range: Confidential.

P 93-1638

**Importer.** Hoechst Celanese Corporation.

**Chemical.** (S) Aluminate (3), hexafluoro-, trillithium.

**Use/Import.** (S) Flux for aluminum welding electrodes. Import range: 25,000 kg/yr.

P 93-1639

**Importer.** Elf Atochem North America, Inc.

**Chemical.** (S) Ethylene, butyl acrylate; glycidyl methacrylate.

**Use/Import.** (S) Impact modifier (compatibilizer for polymer). Import range: Confidential.

P 93-1640

**Manufacturer.** Resinall Corporation.

**Chemical.** (G) Hydrocarbon modified rosin resin.

**Use/Production.** (S) Resin for printing ink. Prod. range: Confidential.

P 93-1641

**Manufacturer.** The Dow Chemical Company.

**Chemical.** (G) Proprietary carboxylated styrene butadiene polymer.

**Use/Production.** (S) Latex for aqueous based can end sealant. Prod. range: Confidential.

P 93-1642

*Manufacturer.* Dow Elanco.  
*Chemical.* (G) Substituted triazole.  
*Use/Production.* (S) Chemical intermediate. Prod. range: Confidential.

P 93-1643

*Manufacturer.* Dow Elanco.  
*Chemical.* (G) Sulfonamide salt.  
*Use/Production.* (S) Chemical intermediate. Prod. range: Confidential.

P 93-1644

*Manufacturer.* Dow Elanco.  
*Chemical.* (G) Condensation product of a urethane dimer and a substituted phenylacrylate ester.  
*Use/Production.* (G) Contained use in an article. Prod. range: 250-1,600 kg/yr.

P 93-1645

*Importer.* Gattefosse Corporation.  
*Chemical.* (S) Glycerol behenate.  
*Use/Import.* (G) Used as an additive in a printing ink, function as a binder that provides cohesion and lubrication. Import range: 1,500-3,000 kg/yr.

P 93-1646

*Manufacturer.* The Dow Chemical Company.  
*Chemical.* (S) Halogenated nitrile.  
*Use/Production.* (G) Process intermediate. Prod. range: Confidential.

P 93-1647

*Manufacturer.* The Dow Chemical Company.  
*Chemical.* (G) Halogenated nitrile.  
*Use/Production.* (G) Process intermediate. Prod. range: Confidential.

P 93-1648

*Importer.* The Dow Chemical Company.  
*Chemical.* (G) Halogenated nitrile.  
*Use/Import.* (G) Process raw material. Import range: Confidential.

P 93-1649

*Importer.* Dow Elanco.  
*Chemical.* (G) Alkylated urea.  
*Use/Import.* (G) Process raw material. Import range: Confidential.

P 93-1650

*Manufacturer.* Confidential.  
*Chemical.* (G) 2-Alkylmercapto-3-alkylbenzothiazole.  
*Use/Production.* (S) Dye intermediate. Prod. range: Confidential.

P 93-1651

*Importer.* Confidential.  
*Chemical.* (G) Metal alkyl chloride.  
*Use/Production.* (S) Dye intermediate. Import range: Confidential.

P 93-1652

*Manufacturer.* Surface Chemists of Florida.

*Chemical.* (G) Stearate salt of a diamine.

*Use/Production.* (G) Anticaking agent. Prod. range: 500,000 kg/yr.

P 93-1653

*Manufacturer.* Ashland Chemical, Inc.  
*Chemical.* (G) Saturated polyester.  
*Use/Production.* (G) Open, non-dispersive. Prod. range: Confidential.

P 93-1654

*Importer.* Confidential.  
*Chemical.* (G) Substituted polyoxyethylene.  
*Use/Import.* (G) Process raw material. Import range: Confidential.

P 93-1655

*Manufacturer.* BASF Corporation.  
*Chemical.* (G) Polybutylene terephthalate copolymer.  
*Use/Production.* (S) Plastic resin for injection molding and compounding. Prod. range: Confidential.

P 93-1656

*Manufacturer.* Confidential.  
*Chemical.* (G) Salted amine-functional urethane.  
*Use/Production.* (S) Plastic resin for injection molding and compounding. Prod. range: Confidential.

P 93-1657

*Manufacturer.* Confidential.  
*Chemical.* (G) Cationic epoxy resin.  
*Use/Production.* (S) Epoxy resin for coatings. Prod. range: 900,000 kg/yr.

P 93-1658

*Manufacturer.* Confidential.  
*Chemical.* (G) Modified polyamide.  
*Use/Production.* (G) Polymeric material; open, non-dispersive use. Prod. range: Confidential.

P 93-1659

*Importer.* Hercules Incorporated.  
*Chemical.* (S) 3-(3,7,7-trimethylbicyclo(4,1,0)heptyl-4)-2-propene-nitrile, Z and E isomers.  
*Use/Import.* (G) Fragrances. Import range: Confidential.

P 93-1660

*Importer.* Ciba-Geigy Corporation.  
*Chemical.* (G) Azo naphthalenedisulfonic acid derivative.  
*Use/Import.* (G) Leather dye. Import range: Confidential.

P 93-1661

*Importer.* Hoechst Celanese Corporation.  
*Chemical.* (G) Polymeric isocyanate.  
*Use/Import.* (S) Flame retardant for plastics. Import range: 4,000-10,000 kg/yr.

P 93-1662

*Importer.* Confidential.

*Chemical.* (G) Trimethylpropane, mixed C<sub>7</sub>-C<sub>9</sub> esters.

*Use/Import.* (G) Refrigeration lubricant ingredient. Import range: Confidential.

P 93-1663

*Importer.* Confidential.  
*Chemical.* (G) Trimethylpropane, mixed C<sub>7</sub>-C<sub>9</sub> esters.  
*Use/Import.* (G) Refrigeration lubricant ingredient. Import range: Confidential.

P 93-1664

*Importer.* Confidential.  
*Chemical.* (G) Polyester/styrene-acrylic grafted resin.  
*Use/Import.* (S) Binder resin of toner and of starter for copy machine. Import range: Confidential.

P 93-1665

*Importer.* Confidential.  
*Chemical.* (G) Benzene, 1-alkyloxy-4-((4-alkylphenyl)ethynyl)-.  
*Use/Import.* (S) Component of liquid crystal mixture for liquid crystal display. Import range: Confidential.

P 93-1666

*Manufacturer.* Confidential.  
*Chemical.* (G) Fatty triglyceride, reaction product with polyethylene polyamine and alkenoic anhydride.  
*Use/Production.* (G) Open, non-dispersive use in energy production. Prod. range: Confidential.

P 93-1667

*Importer.* Spies Hecker, Inc.  
*Chemical.* (S) 2-Propenoic acid, 2-methylpropyl ester; 2-propenoic acid, 2-ethylhexyl ester; 2-propenoic acid, 2-methyl ester; 2-propenoic acid, 2-methyl-, 2-hydroxypropyl ester; 2-propenamide, N-(3-(dimethylamino)propyl)-2-methyl-, hexane, 1,6-diisocyanato-, homopolymer 2H-Azepin-2-one, hexahydro-.  
*Use/Import.* (S) Binder for paint. Import range: 1,000-2,000 kg/yr.

P 93-1668

*Importer.* Henkel Corporation.  
*Chemical.* (S) Fatty acids, C<sub>18</sub> unsaturated dimers, hydrogenated-, dimethyl esters.  
*Use/Import.* (S) Binder for paint. Import range: 1,000-2,000 kg/yr.

P 93-1669

*Importer.* E. I. du Pont de Nemours and Company.  
*Chemical.* (G) Dicarboxylic acids-glycol polymer.  
*Use/Import.* (G) Open, non-dispersive use. Import range: Confidential.

P 93-1670

*Manufacturer.* Confidential.

*Chemical.* (G) Aromatic tetracarboxylic acid, mixed diester with aliphatic alcohols.

*Use/Production.* (G) Closed. Prod. range: Confidential.

**P 93-1671**

*Manufacturer.* Confidential.

*Chemical.* (G) Aromatic tetracarboxylic acid, mixed ester with ester aliphatic alcohols.

*Use/Production.* (S) Used in the manufacture of polyurethane coatings. Prod. range: 100,000 kg/yr.

**P 93-1672**

*Manufacturer.* Henkel Corporation.

*Chemical.* (G) Fatty acids, C<sub>18</sub> unsaturated, dimers, di-methyl esters, hydrogenated.

*Use/Production.* (S) Used in the manufacture of polyurethane coatings. Prod. range: 100,000 kg/yr.

**P 93-1673**

*Manufacturer.* Henkel Corporation.

*Chemical.* (G) Fatty acids, C<sub>18</sub> unsaturated, dimers, hydrogenated di methyl esters, hydrogenated.

*Use/Production.* (S) Used in the manufacture of polyurethane coatings. Prod. range: 100,000 kg/yr.

**P 93-1674**

*Manufacturer.* Olin Corporation.

*Chemical.* (G) Alcohol alkoxylate.

*Use/Production.* (S) Surfactant/rinse aid household automatic dishwashing. Prod. range: Confidential.

**P 93-1675**

*Manufacturer.* Olin Corporation.

*Chemical.* (G) Alcohol alkoxylate.

*Use/Production.* (S) Surfactant/rinse aid household automatic dishwashing. Prod. range: Confidential.

**P 93-1676**

*Manufacturer.* Olin Corporation.

*Chemical.* (G) Alcohol alkoxylate.

*Use/Production.* (S) Surfactant/rinse aid household automatic dishwashing. Prod. range: Confidential.

**P 93-1677**

*Manufacturer.* Olin Corporation.

*Chemical.* (G) Alcohol alkoxylate.

*Use/Production.* (S) Surfactant/rinse aid household automatic dishwashing. Prod. range: Confidential.

**P 93-1678**

*Manufacturer.* Olin Corporation.

*Chemical.* (G) Alcohol alkoxylate.

*Use/Production.* (S) Surfactant/rinse aid household automatic dishwashing. Prod. range: Confidential.

**P 93-1679**

*Manufacturer.* Olin Corporation.

*Chemical.* (G) Alcohol alkoxylate.

*Use/Production.* (S) Surfactant/rinse aid household automatic dishwashing. Prod. range: Confidential.

**P 93-1680**

*Manufacturer.* Olin Corporation.

*Chemical.* (G) Alcohol alkoxylate.

*Use/Production.* (S) Surfactant/rinse aid household automatic dishwashing. Prod. range: Confidential.

**P 93-1681**

*Manufacturer.* Olin Corporation.

*Chemical.* (G) Alcohol alkoxylate.

*Use/Production.* (S) Surfactant/rinse aid household automatic dishwashing. Prod. range: Confidential.

**P 93-1682**

*Manufacturer.* Olin Corporation.

*Chemical.* (G) Alcohol alkoxylate.

*Use/Production.* (S) Surfactant/rinse aid household automatic dishwashing. Prod. range: Confidential.

**P 93-1683**

*Manufacturer.* Olin Corporation.

*Chemical.* (G) Alcohol alkoxylate.

*Use/Production.* (S) Surfactant/rinse aid household automatic dishwashing. Prod. range: Confidential.

**P 93-1684**

*Manufacturer.* Olin Corporation.

*Chemical.* (G) Alcohol alkoxylate.

*Use/Production.* (S) Surfactant/rinse aid household automatic dishwashing. Prod. range: Confidential.

**P 93-1685**

*Manufacturer.* Olin Corporation.

*Chemical.* (G) Alcohol alkoxylate.

*Use/Production.* (S) Surfactant/rinse aid household automatic dishwashing. Prod. range: Confidential.

**P 93-1686**

*Manufacturer.* Olin Corporation.

*Chemical.* (G) Alcohol alkoxylate.

*Use/Production.* (S) Surfactant/rinse aid household automatic dishwashing. Prod. range: Confidential.

**P 93-1687**

*Manufacturer.* Olin Corporation.

*Chemical.* (G) Alcohol alkoxylate.

*Use/Production.* (S) Surfactant/rinse aid household automatic dishwashing. Prod. range: Confidential.

**P 93-1688**

*Manufacturer.* Olin Corporation.

*Chemical.* (G) Alcohol alkoxylate.

*Use/Production.* (S) Surfactant/rinse aid household automatic dishwashing. Prod. range: Confidential.

**P 93-1689**

*Manufacturer.* Confidential.

*Chemical.* (G) Cyclic carbamate ester.

*Use/Production.* (G) Commodity industrial preservative. Prod. range: Confidential.

**P 93-1690**

*Manufacturer.* E. I. du Pont de Nemours and Company.

*Chemical.* (G) Polyamic acid.

*Use/Production.* (G) Open, nondispersive use. Prod. range: Confidential.

**P 93-1691**

*Manufacturer.* Hoechst Celanese Corporation.

*Chemical.* (G) Trisubstituted benzene sulfonic acid.

*Use/Production.* (S) Reactive dye for cellulose or nylon. Prod. range: 5,000-15,000 kg/yr.

**P 93-1692**

*Manufacturer.* Hoechst Celanese Corporation.

*Chemical.* (G) Trisubstituted benzene sulfonic acid.

*Use/Production.* (S) Reactive dye for cellulose or nylon. Prod. range: 5,000-15,000 kg/yr.

**P 93-1693**

*Manufacturer.* Arizona Chemical Company.

*Chemical.* (G) Modified olefinic hydrocarbon resin.

*Use/Production.* (G) Printing ink resin. Prod. range: Confidential.

**P 93-1694**

*Manufacturer.* Monsanto Company.

*Chemical.* (S) 3-(Dichloroacetyl)-5-(2-furanyl)-2,2-dimethylloxazolidine.

*Use/Production.* (S) Pesticide safening agent/seed softener. Prod. range: Confidential.

**P 93-1695**

*Importer.* Hoechst Celanese Corporation.

*Chemical.* (G) Modified polyurethane resin.

*Use/Import.* (S) Component of industrial coatings. Import range: 10,500-52,500 kg/yr.

**P 93-1696**

*Manufacturer.* Confidential.

*Chemical.* (G) Carboxylated block polyester polyether isocyanurate adduct.

*Use/Production.* (G) Paint additive for open, nondispersed use. Prod. range: Confidential.

**P 93-1697**

*Manufacturer.* Reichhold Chemicals, Inc.

*Chemical.* (G) Anionic aliphatic polyurethane dispersion.

*Use/Production.* (S) Wood coating. Prod. range: Confidential.

P 93-1698

*Manufacturer.* H. B. Fuller Company.  
*Chemical.* (G) Polymer polyol isocyanate polymer.

*Use/Production.* (S) Intermediate/adhesive. Prod. range: Confidential.

P 93-1699

*Manufacturer.* H. B. Fuller Company.  
*Chemical.* (G) Polyester polyol isocyanate polymer.

*Use/Production.* (S) Intermediate/adhesive. Prod. range: Confidential.

P 93-1700

*Manufacturer.* H. B. Fuller.  
*Chemical.* (G) Polyester polyol isocyanate polymer.

*Use/Production.* (S) Intermediate/adhesive. Prod. range: Confidential.

P 93-1701

*Manufacturer.* H. B. Fuller Company.  
*Chemical.* (G) Polyester polyol isocyanate polymer.

*Use/Production.* (S) Intermediate/adhesive. Prod. range: Confidential.

P 93-1702

*Manufacturer.* H. B. Fuller Company.  
*Chemical.* (G) Polyester polyol isocyanate polymer reaction products.

*Use/Production.* (S) Intermediate/adhesive. Prod. range: Confidential.

P 93-1703

*Manufacturer.* H. B. Fuller Company.  
*Chemical.* (G) Polyester polyol isocyanate polymer reaction products.

*Use/Production.* (S) Intermediate/adhesive. Prod. range: Confidential.

P 93-1704

*Manufacturer.* H. B. Fuller Company.  
*Chemical.* (G) Polyester polyol isocyanate polymer reaction products.

*Use/Production.* (S) Intermediate/adhesive. Prod. range: Confidential.

P 93-1705

*Manufacturer.* H. B. Fuller Company.  
*Chemical.* (G) Polyester polyol isocyanate polymer reaction products.

*Use/Production.* (S) Intermediate/adhesive. Prod. range: Confidential.

P 93-1706

*Manufacturer.* Westvaco Corporation.  
*Chemical.* (G) Styrene modified rosin ester polymer.

*Use/Production.* (G) Resin for printing inks. Prod. range: Confidential.

P 93-1707

*Manufacturer.* Westvaco Corporation.  
*Chemical.* (G) Ammonium salt of styrene modified rosin ester polymer.

*Use/Production.* (S) Solvent based salt, rosin ester salt. Prod. range: Confidential.

P 93-1708

*Manufacturer.* Westvaco Corporation.  
*Chemical.* (G) Monoethanolamine salt of styrene modified rosin ester polymer.

*Use/Production.* (S) Solvent based printing ink binder, rosin ester salt. Prod. range: Confidential.

P 93-1709

*Manufacturer.* Westvaco Corporation.  
*Chemical.* (G) Morpholine salt of styrene modified rosin ester polymer.

*Use/Production.* (S) Solvent based printing ink binder, rosin ester salt. Prod. range: Confidential.

P 93-1710

*Manufacturer.* Westvaco Corporation.  
*Chemical.* (G) Dimethylaminoethanol salt of styrene modified rosin ester polymer.

*Use/Production.* (S) Solvent based printing ink binder, rosin ester salt. Prod. range: Confidential.

P 93-1711

*Manufacturer.* Westvaco Corporation.  
*Chemical.* (G) Aminomethylpropanol salt of styrene modified rosin ester polymer.

*Use/Production.* (S) Solvent based printing ink binder, rosin ester salt. Prod. range: Confidential.

P 93-1712

*Manufacturer.* Westvaco Corporation.  
*Chemical.* (G) Triethylamine salt of styrene modified rosin ester polymer.

*Use/Production.* (S) Solvent based printing ink binder, rosin ester salt. Prod. range: Confidential.

P 93-1713

*Manufacturer.* Westvaco Corporation.  
*Chemical.* (G) Diethylethanolamine salt of styrene modified rosin ester polymer.

*Use/Production.* (S) Solvent based printing ink binder, rosin ester salt. Prod. range: Confidential.

P 93-1714

*Manufacturer.* Westvaco Corporation.  
*Chemical.* (G) Sodium salt of styrene modified rosin ester polymer.

*Use/Production.* (S) Solvent based printing ink binder, rosin ester salt. Prod. range: Confidential.

P 93-1715

*Manufacturer.* Confidential.  
*Chemical.* (S) Pentaerythritol, complex ester with adipic acid, isononanoic acid, acid and pentanoic acids.

*Use/Production.* (S) The PMN substances function as binders in lithographic and publication gravure printing inks. Prod. range: Confidential.

P 93-1716

*Manufacturer.* Confidential.

*Chemical.* (G) Rosin, maleated, polymer with alkylphenols, formaldehyde, modifiers and a polyol.  
*Use/Production.* (S) The PMN substances function as binders in lithographic and publication gravure printing inks. Prod. range: Confidential.

P 93-1717

*Manufacturer.* Confidential.  
*Chemical.* (G) Rosin, maleated, polymer with alkylphenols, formaldehyde, modifiers and a polyol.  
*Use/Production.* (S) The PMN substances function as binders in lithographic and publication gravure printing inks. Prod. range: Confidential.

P 93-1718

*Manufacturer.* Confidential.  
*Chemical.* (G) Rosin, maleated, polymer with alkylphenols, formaldehyde, modifiers and a polyol.  
*Use/Production.* (S) The PMN substances function as binders in lithographic and publication gravure printing inks. Prod. range: Confidential.

P 93-1719

*Manufacturer.* Confidential.  
*Chemical.* (G) Rosin, maleated, polymer with alkylphenols, formaldehyde, modifiers and a polyol.  
*Use/Production.* (S) The PMN substances function as binders in lithographic and publication gravure printing inks. Prod. range: Confidential.

P 93-1720

*Manufacturer.* Confidential.  
*Chemical.* (G) Rosin, amaleated, polymer with alkylphenols, formaldehyde, modifiers and a polyol.  
*Use/Production.* (S) The PMN substances function as binders in lithographic and publication gravure printing inks. Prod. range: Confidential.

P 93-1721

*Manufacturer.* Confidential.  
*Chemical.* (G) Rosin, maleated, polymer with alkylphenols, formaldehyde, modifiers and a polyol.  
*Use/Production.* (S) The PMN substances function as binders in lithographic and publication gravure printing inks. Prod. range: Confidential.

P 93-1722

*Manufacturer.* Confidential.  
*Chemical.* (G) Rosin maleated, polymer with alkylphenols, formaldehyde, modifiers and a polyol.  
*Use/Production.* (S) The PMN substances function as binders in lithographic and publication gravure printing inks. Prod. range: Confidential.

P 93-1723

*Manufacturer.* Confidential.

*Chemical.* (G) Rosin, maleated, polymer with alkylphenols, formaldehyde, modifiers and a polyol.  
*Use/Production.* (S) The PMN substances function as binders in lithographic and publication gravure printing inks. Prod. range: Confidential.

P 93-1724

*Manufacturer.* Confidential.  
*Chemical.* (G) Rosin, maleated, polymer with alkylphenols, formaldehyde, modifiers and a polyol.  
*Use/Production.* (S) The PMN substances function as binders in lithographic and publication gravure printing inks. Prod. range: Confidential.

P 93-1725

*Manufacturer.* Confidential.  
*Chemical.* (G) Rosin, maleated, polymer with alkylphenols, formaldehyde, modifiers and a polyol.  
*Use/Production.* (S) The PMN substances function as binders in lithographic and publication gravure printing inks. Prod. range: Confidential.

P 93-1726

*Manufacturer.* Confidential.  
*Chemical.* (G) Rosin, maleated, polymer with alkylphenols, formaldehyde, modifiers and a polyol.  
*Use/Production.* (S) The PMN substances function as binders in lithographic and publication gravure printing inks. Prod. range: Confidential.

P 93-1727

*Manufacturer.* Confidential.  
*Chemical.* (G) Rosin, maleated, polymer with alkylphenols, formaldehyde, modifiers and a polyol.  
*Use/Production.* (S) The PMN substances function as binders in lithographic and publication gravure printing inks. Prod. range: Confidential.

P 93-1728

*Manufacturer.* Confidential.  
*Chemical.* (G) Rosin, maleated, polymer with alkylphenols, formaldehyde, modifiers and a polyol.  
*Use/Production.* (S) The PMN substances function as binders in lithographic and publication gravure printing inks. Prod. range: Confidential.

P 93-1729

*Manufacturer.* Confidential.  
*Chemical.* (G) Rosin, maleated, polymer with alkylphenols, formaldehyde, modifiers and a polyol.  
*Use/Production.* (S) The PMN substances function as binders in lithographic and publication gravure printing inks. Prod. range: Confidential.

P 93-1730

*Manufacturer.* Confidential.

*Chemical.* (G) Rosin, maleated, polymer with alkylphenols, formaldehyde, modifiers and a polyol.  
*Use/Production.* (S) The PMN substances function as binders in lithographic and publication gravure printing inks. Prod. range: Confidential.

P 93-1731

*Manufacturer.* Henkel Corporation.  
*Chemical.* (S) Pentaerythritol, complex ester with adipic acid, isononanoic acid, and pentanoic acids.  
*Use/Production.* (S) Lubricant basestock for refrigeration compressor. Prod. range: 5,000-80,000 kg/yr.

P 93-1732

*Manufacturer.* Henkel Corporation.  
*Chemical.* (S) Pentaerythritol, complex ester with adipic acid, 3,5,5-trimethyl hexanoic acid and pentanoic acids.  
*Use/Production.* (S) Lubricant basestock for refrigeration compressor. Prod. range: 5,000-80,000 kg/yr.

P 93-1733

*Manufacturer.* Henkel Corporation.  
*Chemical.* (S) Pentaerythritol, complex ester with adipic acid, isononanoic, 3,5,5-trimethyl hexanoic acid and pentanoic acid.  
*Use/Production.* (S) Lubricant basestock for refrigeration compressor. Prod. range: 5,000-80,000 kg/yr.

P 93-1734

*Manufacturer.* Sangi Group America.  
*Chemical.* (G) Additive to plastics, paints and coatings, cosmetics, fibers, and activated charcoal.  
*Use/Production.* (G) Additive to plastics, paints, coatings, cosmetics and activated charcoal. Prod. range: Confidential.

P 93-1735

*Importer.* Ciba-Geigy Corporation.  
*Chemical.* (G) Substituted aminoalkylazobenzene.  
*Use/Import.* (S) Dyestuff intermediate. Import range: Confidential.

P 93-1736

*Importer.* Sangi Group America.  
*Chemical.* (G) Silver zinc calcium phosphate.  
*Use/Production.* (G) Additive to plastics, paints, coatings, cosmetics and activated charcoal. Prod. range: Confidential.

P 93-1737

*Importer.* Raschig Corporation.  
*Chemical.* (G) Akyalkoxylylate, sulfopropylated.  
*Use/Import.* (S) Electroplating brighteners. Import range: Confidential.

P 93-1738

*Manufacturer.* Confidential.

*Chemical.* (G) Polyurethane.  
*Use/Production.* (S) Isocyanate component of a two part urethane coding system. Prod. range: Confidential.

P 93-1739

*Manufacturer.* Hydrolabs, Inc.  
*Chemical.* (G) Siloxanes and silicones, dimethyl, amine terminated.  
*Use/Production.* (G) Textile fabric finish. Prod. range: Confidential.

#### List of Subjects

Environmental protection,  
Premanufacture notification.

Dated: April 7, 1994.

Frank V. Caesar,

Acting Director, Information Management  
Division, Office of Pollution Prevention and  
Toxics.

[FR Doc. 94-9296 Filed 4-15-94; 8:45 am]  
BILLING CODE 6560-50-F

[FRL-4863-9]

#### Notice of Proposed Administrative Settlement Pursuant to the Comprehensive Environmental Response, Compensation, and Liability Act, as Amended by the Superfund Amendments and Reauthorization Act

AGENCY: Environmental Protection Agency.

ACTION: Notice, request for public comment.

**SUMMARY:** In accordance with section 122(i) of the Comprehensive Environmental Response, Compensation and Liability Act of 1980 (CERCLA), as amended by the Superfund Amendments and Reauthorization Act of 1986 (SARA), notice is hereby given that a proposed administrative cost recovery settlement concerning the Lee Chemical Company Site ("The Site") located in Clay County, Missouri is issued by the Agency on March 4, 1994. The settlement resolves Agency claims under section 107 of CERCLA against the City of Liberty, Missouri, the U.S. Department of Energy, and Allied Signal, Inc. ("The Settling Parties"). The settlement requires the Settling Parties to pay response costs in the amount of \$389,522.33 to the Hazardous Substance Superfund.

For thirty (30) days following the date of the publication of this notice, the Agency will accept written comments relating to the settlement. The Agency's response to any comments received will be available for public inspection at the EPA Region 7 Office, located at 726 Minnesota Avenue in Kansas City, Kansas 66101.

**DATES:** Comments must be submitted on or before May 18, 1994.

**ADDRESSES:** The proposed settlement and additional background information relating to the settlement are available for public inspection during weekday business hours at the EPA Region 7 Office at 726 Minnesota Avenue in Kansas City, Kansas 66101 or at the City of Liberty Public Works Maintenance Facility at 400 Suddarth, Liberty, Missouri 64068. A copy of the proposed settlement may be obtained from Vanessa Cobbs, Regional Docket Clerk, EPA Region 7, 726 Minnesota Avenue, Kansas City, Kansas 66101, telephone: (913) 551-7630.

Comments on the proposed settlement should reference the Lee Chemical Company Site, in Clay County, Missouri and EPA Docket No. VII-94-F-0006 and should be addressed to Ms. Cobbs at the address above.

**FOR FURTHER INFORMATION CONTACT:** Ms. Leslie Humphrey, Assistant Regional Counsel, EPA Region 7, Office of Regional Counsel, 726 Minnesota Avenue, Kansas City, Kansas 66101, telephone: (913) 551-7227.

Dated: March 21, 1994.

**Michael J. Sanderson,**  
*Acting Director, Waste Management Division,*  
*U.S. EPA Region 7.*

[FR Doc. 94-9290 Filed 4-15-94; 8:45 am]

BILLING CODE 6560-50-M

[OPPTS-42052Q; FRL-4776-5]

### Notice of Opportunity to Participate in Negotiations for Testing of ETBE and TAME Under TSCA Section 4

**AGENCY:** Environmental Protection Agency (EPA).

**ACTION:** Notice.

**SUMMARY:** This notice invites manufacturers and processors of ethyl tert-butyl ether (ETBE)(CAS No. 637-92-3) and tertiary-amyl methyl ether (TAME)(CAS No. 994-05-8) and other interested persons who wish to participate in or monitor consent agreement negotiations pursuant to 40 CFR 790.22(b) to contact the EPA in writing. In addition, this notice announces a public meeting to initiate testing negotiations for these chemicals. **DATES:** A meeting to initiate testing negotiations for these chemicals will be held at the Environmental Protection Agency from 1 p.m. to 3 p.m., May 9, 1994. For a person to be designated an "interested party" for these negotiations, written notice must be received by EPA on or before May 2, 1994.

**ADDRESSES:** The public meeting will be held at the Environmental Protection Agency, Room 1605, Northeast Mall, 401 M St., SW., Washington, DC. Submit written requests to be designated an interested party to TSCA Docket Receipts (7407), Office of Pollution Prevention and Toxics, Environmental Protection Agency, Rm. ET G-99, 401 M St., SW., Washington, DC 20460. Submissions should bear the document control number [OPPTS-42052Q]. The public docket supporting this action is available for public inspection in Room ET G-102 at the above address from 12 noon to 4 p.m., Monday through Friday, except legal holidays.

**FOR FURTHER INFORMATION CONTACT:** Susan B. Hazen, Director, Environmental Assistance Division, (7408), Office of Pollution Prevention and Toxics, Environmental Protection Agency, Rm. E-543B, 401 M St., SW., Washington, DC 20460, (202) 260-7335. **SUPPLEMENTARY INFORMATION:** This notice announces an opportunity to participate in negotiations for an enforceable consent agreement for: ETBE (Docket No. 42052Q/42179) and TAME (Docket No. 42052Q/42180).

### I. Background

Requirements of the Clean Air Act (CAA), 42 U.S.C. 7401-1671q, along with reports of adverse human health effects associated with the use of methyl tertiary-butyl ether (MTBE) in winter-blend gasoline, have contributed to the need for health effects testing of ETBE and TAME.

MTBE, ETBE and TAME are fuel oxygenates which may be used to satisfy the following requirements under the CAA. Under section 211(m) of the CAA, 42 U.S.C. 7545, states which have certain nonattainment areas for carbon monoxide (CO) must require that any gasoline sold or dispensed to ultimate consumers in a specified portion of the nonattainment area be blended, during wintertime, to contain not less than 2.7 percent oxygen by weight (or applicable percentage to meet the national primary air quality standard for CO by the established attainment date). Under section 211(k), reformulated gasoline must be used in nine major metropolitan areas designated as ozone nonattainment areas as well as various nonattainment "opt-in" areas by 1995 and the oxygen content of this gasoline must be equal to or exceed 2 percent by weight. See Final Rule, Regulation of Fuels and Fuel Additives: Standards for Reformulated and Conventional Gasoline, February 16, 1994 (59 FR 7716). In addition, a proposed regulation would require that at least 30

percent of the oxygen content in reformulated gasoline come from renewable oxygenates, which would include ETBE (Notice of Proposed Rulemaking, Regulation of Fuels and Additives: Renewable Oxygenate Requirement for Reformulated Gasoline, December 27, 1993 (58 FR 68343)).

Recently there have been reports from the State of Alaska and several areas in the lower 48 of adverse human effects associated with the use of MTBE in winter-blend gasoline. See Assessment of Potential Health Risks of Gasoline Oxygenated with MTBE, Office of Research and Development, U.S. EPA, November 1993.

EPA believes that additional health effects test data on fuel oxygenates are needed to allow government agencies and industry to compare the health risks associated with the use of these substances to augment or substitute for MTBE as a fuel oxygenate. For this reason, researchers and policy makers from EPA's Office of Air and Radiation (OAR) and Office of Research and Development (ORD) initiated a conference with the State of Alaska, the Centers for Disease Control and Prevention, and the chemical and petroleum industries in Research Triangle Park, NC on December 7-8, 1993 to discuss research on the health effects of and human exposure to fuel oxygenates.

One of the products of this meeting was a research project proposal to conduct toxicity testing to develop a broad base of health effects data on ETBE and TAME. The research proposal was developed to expedite the process of identifying data needs on these substances. The research proposal recommends testing of ETBE and TAME for the following endpoints:

- 1st Tier genotoxicity
- 90-day inhalation subchronic Neurotoxicity (Functional observational battery, neuropathology, motor activity)
- Developmental toxicity
- Reproductive effects
- Pharmacokinetics

### II. Testing Program

EPA's Office of Pollution Prevention and Toxics (OPPT) administers the Toxic Substances Control Act (TSCA) and the TSCA section 4 testing program. Under TSCA section 4, 15 U.S.C. 2603, EPA may require, in specific circumstances, that chemical manufacturers and processors provide to EPA test data that can be used to assess the impact on human health and the environment from exposure to such chemicals. In addition to imposing section 4 testing requirements by rulemaking, OPPT has developed an

enforceable consent agreement (ECA) process for obtaining needed testing often with less time and resources and more flexibility than under a test rule. See 40 CFR part 790. Finally, industry may conduct voluntary testing of specific chemicals in anticipation of data needs.

In a memorandum dated March 1, 1994, EPA's OAR requested OPPT to inquire regarding the likelihood that industry would develop a voluntary testing program for ETBE and TAME. In the absence of such a voluntary commitment, OAR requested that OPPT use its authority under TSCA to require such testing.

OPPT sent out a form letter dated March 1, 1994 to approximately 45 chemical and petroleum companies. The letter described the December 7, 1993 meeting and enclosed a copy of the research proposal developed at that meeting, and sought to establish a dialogue with industry regarding the testing of ETBE and TAME.

Subsequently, OPPT elected to pursue the testing of ETBE and TAME through the ECA process. The purpose of the meeting on May 9, 1994 is to initiate negotiations for the development of an ECA for the testing of ETBE and TAME. If an ECA approach does not appear feasible, EPA will initiate rulemaking under section 4 of TSCA to require the development of data on ETBE and TAME.

EPA is adding ETBE and TAME to the Master Testing List (MTL), which sets priorities for OPPT's testing agenda, because EPA considers testing of these substances to be a high priority. EPA has been using the MTL since 1990 to set the Agency's testing agenda and communicate it to the public.

### III. Public Docket

The following documents are available for public inspection in the public docket. The location and hours of the public docket supporting this action are set forth under the "Addresses" section above.

1. Assessment of Potential Health Risks of Gasoline Oxygenated with MTBE, Office of Research and Development, U.S. EPA, November 1993.

2. Report of Meeting to Develop Proposed Research Projects for Oxyfuels, Research Triangle Park, NC, December 7-8, 1993.

3. Letter from Mary T. Smith, Director of Field Operations and Support Division, Office of Air and Radiation, to Charles M. Auer, Director of Chemical Control Division, Office of Prevention, Pesticides and Toxic Substances, March 1, 1994.

4. Letter from Joseph S. Carra, Deputy Director of Office of Pollution Prevention and Toxics, to approximately 45 chemical and petroleum companies, and attachment (plus addressee list).

5. Unsolicited proposal for testing of ETBE and TAME from the American Petroleum Institute.

Authority: 15 U.S.C. 2603.

Dated: April 8, 1994.

Charles M. Auer,  
Director, Chemical Control Division.

[FR Doc. 94-9287 Filed 4-14-93; 8:45 am]

BILLING CODE 6560-50-F

### [OPPTS-51829; FRL-4775-8]

#### Certain Chemicals; Premanufacture Notices

AGENCY: Environmental Protection Agency (EPA).

ACTION: Notice.

**SUMMARY:** Section 5(a)(1) of the Toxic Substances Control Act (TSCA) requires any person who intends to manufacture or import a new chemical substance to submit a premanufacture notice (PMN) to EPA at least 90 days before manufacture or import commences. Statutory requirements for section 5(a)(1) premanufacture notices are discussed in the final rule published in the *Federal Register* of May 13, 1983 (48 FR 21722). This notice announces receipt of 200 such PMNs and provides a summary of each.

**DATES:** Close of review periods:

P 94-1, December 29, 1993.

P 94-2, 94-3, 94-4, 94-5, 94-6, 94-7, 94-8, 94-9, 94-10, 94-11, 94-12, January 1, 1994.

P 94-13, 94-14, 94-15, 94-16, 94-17, 94-18, 94-19, 94-20, 94-21, 94-22, December 29, 1993.

P 94-23, January 1, 1994.

P 94-24, January 2, 1994.

P 94-25, January 1, 1994.

P 94-26, 94-27, 94-28, January 2, 1994.

P 94-29, 94-30, 94-31, January 3, 1994.

P 94-32, January 4, 1994.

P 94-33, January 5, 1994.

P 94-34, January 4, 1994.

P 94-35, 94-36, January 9, 1994.

P 94-37, January 10, 1994.

P 94-38, 94-39, 94-40, 94-41,

January 11, 1994.

P 94-42, 94-43, 94-44, 94-45, 94-46,

January 10, 1994.

P 94-47, 94-48, 94-49, 94-50, 94-51,

January 11, 1994.

P 94-52, 94-53, 94-54, 94-55,

January 12, 1994.

P 94-56, January 10, 1994.

P 94-57, 94-58, 94-59, January 12, 1994.

P 94-60, 94-61, 94-62, 94-63, 94-64, 94-65, 94-66, 94-67, 94-68, 94-69, 94-70, 94-71, 94-72, 94-73, 94-74, 94-75, January 15, 1994.

P 94-76, 94-77, January 16, 1994.

P 94-78, 94-79, 94-80, 94-81, 94-82, 94-83, 94-84, 94-85, 94-86, 94-87, 94-88, January 17, 1994.

P 94-89, January 18, 1994.

P 94-90, 94-91, 94-92, January 17, 1994.

P 94-93, 94-94, 94-95, 94-96, 94-97, January 19, 1994.

P 94-98, 94-99, 94-100, January 22, 1994.

P 94-101, 94-102, 94-103, 94-104, January 23, 1994.

P 94-105, 94-106, 94-107, 94-108, 94-109, 94-110, 94-111, 94-112, 94-113, 94-114, January 24, 1994.

P 94-115, January 23, 1994.

P 94-116, January 25, 1994.

P 94-117, 94-118, 94-119, 94-120, 94-121, 94-122, January 26, 1994.

P 94-123, 94-124, January 29, 1994.

P 94-125, 94-126, January 26, 1994.

P 94-127, January 29, 1994.

P 94-128, 94-129, January 25, 1994.

P 94-130, January 30, 1994.

P 94-131, 94-132, 94-133, 94-134,

94-135, January 31, 1994.

P 94-136, 94-137, 94-138, 94-139,

February 1, 1994.

P 94-140, 94-141, 94-142, 94-143,

February 2, 1994.

P 94-144, 94-145, 94-146, 94-147,

94-148, 94-149, 94-150, 94-151, 94-

152, 94-153, 94-154, 94-155, 94-156,

94-157, 94-158, 94-159, 94-160, 94-

161, 94-162, 94-163, 94-164, 94-165,

94-166, 94-167, 94-168, 94-169, 94-

170, 94-171, 94-172, 94-173, 94-174,

February 5, 1994.

P 94-175, January 31, 1994.

P 94-176, 94-177, 94-178, 94-179,

94-180, 94-181, 94-182, 94-183, 94-

184, 94-185, 94-186, 94-187, 94-188,

94-189, 94-190, 94-191, 94-192, 94-

193, 94-194, 94-195, 94-196, 94-197,

94-198, 94-199, 94-200, February 5,

1994.

Written comments by:

P 94-1, November 29, 1993.

P 94-2, 94-3, 94-4, 94-5, 94-6, 94-7, 94-8, 94-9, 94-10, 94-11, 94-12, December 2, 1993.

P 94-13, 94-14, 94-15, 94-16, 94-17, 94-18, 94-19, 94-20, 94-21, 94-22, November 29, 1993.

P 94-23, December 2, 1993.

P 94-24, December 3, 1993.

P 94-25, December 2, 1993.

P 94-26, 94-27, 94-28, December 3, 1993.

P 94-29, 94-30, 94-31, December 4, 1993.



P 94-32, December 5, 1993.  
 P 94-33, December 6, 1993.  
 P 94-34, December 5, 1993.  
 P 94-35, 94-36, December 10, 1993.  
 P 94-37, December 11, 1993.  
 P 94-38, 94-39, 94-40, 94-41, December 12, 1993.  
 P 94-42, 94-43, 94-44, 94-45, 94-46, December 11, 1993.  
 P 94-47, 94-48, 94-49, 94-50, 94-51, December 12, 1993.  
 P 94-52, 94-53, 94-54, 94-55, December 13, 1993.  
 P 94-56, December 11, 1993.  
 P 94-57, 94-58, 94-59, December 13, 1993.  
 P 94-60, 94-61, 94-62, 94-63, 94-64, 94-65, 94-66, 94-67, 94-68, 94-69, 94-70, 94-71, 94-72, 94-73, 94-74, 94-75, December 16, 1993.  
 P 94-76, 94-77, December 17, 1993.  
 P 94-78, 94-79, 94-80, 94-81, 94-82, 94-83, 94-84, 94-85, 94-86, 94-87, 94-88, December 18, 1993.  
 P 94-89, December 19, 1993.  
 P 94-90, 94-91, 94-92, December 18, 1993.  
 P 94-93, 94-94, 94-95, 94-96, 94-97, December 20, 1993.  
 P 94-98, 94-99, 94-100, December 23, 1993.  
 P 94-101, 94-102, 94-103, 94-104, December 24, 1993.  
 P 94-105, 94-106, 94-107, 94-108, 94-109, 94-110, 94-111, 94-112, 94-113, 94-114, December 25, 1993.  
 P 94-115, December 24, 1993.  
 P 94-116, December 26, 1993.  
 P 94-117, 94-118, 94-119, 94-120, 94-121, 94-122, December 27, 1993.  
 P 94-123, 94-124, December 30, 1993.  
 P 94-125, 94-126, December 27, 1993.  
 P 94-127, December 30, 1993.  
 P 94-128, 94-129, December 26, 1993.  
 P 94-130, December 31, 1993.  
 P 94-131, 94-132, 94-133, 94-134, 94-135, January 1, 1994.  
 P 94-136, 94-137, 94-138, 94-139, January 2, 1994.  
 P 94-140, 94-141, 94-142, 94-143, January 6, 1994.  
 P 94-144, 94-145, 94-146, 94-147, 94-148, 94-149, 94-150, 94-151, 94-152, 94-153, 94-154, 94-155, 94-156, 94-157, 94-158, 94-159, 94-160, 94-161, 94-162, 94-163, 94-164, 94-165, 94-166, 94-167, 94-168, 94-169, 94-170, 94-171, 94-172, 94-173, 94-174, January 6, 1994.  
 P 94-175, January 1, 1994.  
 P 94-176, 94-177, 94-178, 94-179, 94-180, 94-181, 94-182, 94-183, 94-184, 94-185, 94-186, 94-187, 94-188, 94-189, 94-190, 94-191, 94-192, 94-193, 94-194, 94-195, 94-196, 94-197, 94-198, 94-199, 94-200, January 6, 1994.

**ADDRESSES:** Written comments, identified by the document control

number "[OPPTS-51829]" and the specific PMN number should be sent to: Document Control Office (7407), Office of Pollution Prevention and Toxics, Environmental Protection Agency, 401 M St., SW., Rm. ETG-099 Washington, DC 20460 (202) 260-1532.

**FOR FURTHER INFORMATION CONTACT:** Susan B. Hazen, Director, Environmental Assistance Division (7408), Office of Pollution Prevention and Toxics, Environmental Protection Agency, Rm. E-545, 401 M St., SW., Washington, DC, 20460 (202) 554-1404, TDD (202) 554-0551.

**SUPPLEMENTARY INFORMATION:** The following notice contains information extracted from the nonconfidential version of the submission provided by the manufacturer on the PMNs received by EPA. The complete nonconfidential document is available in the TSCA Nonconfidential Information Center (NCIC), ETG-102 at the above address between 12 noon and 4 p.m., Monday through Friday, excluding legal holidays.

**P 94-1**

*Importer.* Confidential.  
*Chemical.* (G) Polymer ester.  
*Use/Import.* (G) Industrial lubricant.  
 Import range: Confidential.

**P 94-2**

*Manufacturer.* Confidential.  
*Chemical.* (G) Alkyl phosphoric acid ester.  
*Use/Production.* (G) Industrial lubricant. Prod. range: Confidential.

**P 94-3**

*Manufacturer.* Confidential.  
*Chemical.* (G) Alkyl phosphoric acid ester.  
*Use/Production.* (G) Chemical intermediate. Prod. range: Confidential.

**P 94-4**

*Manufacturer.* Confidential.  
*Chemical.* (G) Alkyl phosphoric acid ester salts.  
*Use/Production.* (G) Fiber treatment chemical. Prod. range: Confidential.

**P 94-5**

*Manufacturer.* Confidential.  
*Chemical.* (G) Alkyl phosphoric acid ester salts.  
*Use/Production.* (G) Fiber treatment chemical. Prod. range: Confidential.

**P 94-6**

*Manufacturer.* Confidential.  
*Chemical.* (G) Alkyl phosphoric acid ester resin.  
*Use/Production.* (S) Fiber treatment chemical. Prod. range: Confidential.

**P 94-7**

*Manufacturer.* Confidential.

*Chemical.* (G) Alkyl phosphoric acid ester resin.  
*Use/Production.* (G) Fiber treatment chemical. Prod. range: Confidential.

**P 94-8**

*Manufacturer.* Confidential.  
*Chemical.* (G) Alkyl phosphoric acid ester resin.  
*Use/Production.* (G) Fiber treatment chemical. Prod. range: Confidential.

**P 94-9**

*Manufacturer.* Confidential.  
*Chemical.* (G) Alkyl phosphoric acid ester salts.  
*Use/Production.* (G) Fiber treatment chemical. Prod. range: Confidential.

**P 94-10**

*Manufacturer.* Confidential.  
*Chemical.* (G) Alkyl phosphoric acid ester salts.  
*Use/Production.* (G) Fiber treatment chemical. Prod. range: Confidential.

**P 94-11**

*Manufacturer.* Confidential.  
*Chemical.* (G) Alkyl phosphoric acid ester salts.  
*Use/Production.* (G) Fiber treatment chemical. Prod. range: Confidential.

**P 94-12**

*Manufacturer.* Confidential.  
*Chemical.* (G) Alkyl phosphoric acid esters salts.  
*Use/Production.* (G) Fiber treatment chemical. Prod. range: Confidential.

**P 94-13**

*Importer.* Confidential.  
*Chemical.* (G) Hydrophilic polymer dispersant.  
*Use/Import.* (G) Automotive refinish exterior coatings. Import range: Confidential.

**P 94-14**

*Importer.* Confidential.  
*Chemical.* (G) Hydrophilic polymer dispersant.  
*Use/Import.* (G) Automotive refinish exterior coating. Import range: Confidential.

**P 94-15**

*Importer.* Confidential.  
*Chemical.* (G) Hydrophilic polymer dispersant.  
*Use/Import.* (G) Automotive refinish exterior coating. Import range: Confidential.

**P 94-16**

*Importer.* Confidential.  
*Chemical.* (G) Hydrophilic polymer dispersant.  
*Use/Import.* (G) Automotive refinish exterior coating. Import range: Confidential.

## P 94-17

*Importer.* Confidential.  
*Chemical.* (G) Hydrophilic polymer dispersant.  
*Use/Import.* (G) Automotive refinish exterior coating. Import range: Confidential.

## P 94-18

*Importer.* Confidential.  
*Chemical.* (G) Cross-linked hydrophilic latex.  
*Use/Import.* (G) Automotive refinish exterior coating. Import range: Confidential.

## P 94-19

*Importer.* Confidential.  
*Chemical.* (G) Cross-linked hydrophilic latex.  
*Use/Import.* (G) Automotive refinish exterior coating. Import range: Confidential.

## P 94-20

*Importer.* Confidential.  
*Chemical.* (G) Cross-linked hydrophilic latex.  
*Use/Import.* (G) Automotive refinish exterior coating. Import range: Confidential.

## P 94-21

*Importer.* Confidential.  
*Chemical.* (G) Cross-linked hydrophilic latex.  
*Use/Import.* (G) Automotive refinish exterior coating. Import range: Confidential.

## P 94-22

*Importer.* Confidential.  
*Chemical.* (G) Cross-linked hydrophilic latex.  
*Use/Import.* (G) Automotive refinish exterior coating. Import range: Confidential.

## P 94-23

*Importer.* Confidential.  
*Chemical.* (G) Disubstituted benzene acetic acid.  
*Use/Import.* (S) Agricultural chemical intermediate. Import range: Confidential.

## P 94-24

*Manufacturer.* High Point Chemical Company.  
*Chemical.* (S) Ethanaminium, 2-hydroxy-*N,N*-bis(2-hydroxyethyl), *N*-ethyl-diester with C<sub>12</sub>-18 fatty acids, ethyl sulfate (salt).  
*Use/Production.* (S) Fiber finish on natural and synthetic fibers in the textile industry. Prod. range: Confidential.

## P 94-25

*Manufacturer.* Confidential.

*Chemical.* (G) Polyamide resin.  
*Use/Production.* (G) Paper additive.  
 Prod. range: Confidential.

## P 94-26

*Manufacturer.* Avery Dennison Chemical Division.  
*Chemical.* (G) Non-volatile acrylic copolymer.  
*Use/Production.* (G) Pressure sensitive adhesive. Prod. range: Confidential.

## P 94-27

*Importer.* Hoechst Celanese Corporation.  
*Chemical.* (G) Modified polyurethane resin, salt (formate).  
*Use/Import.* (G) Component of industrial coatings. Import range: 17,000-35,000 kg/yr.

## P 94-28

*Importer.* Hoechst Celanese Corporation.  
*Chemical.* (G) Modified bisphenol-A-epoxide resin.  
*Use/Import.* (G) Component of industrial coatings. Import range: 17,000-87,500 kg/yr.

## P 94-29

*Manufacturer.* Confidential.  
*Chemical.* (G) Dialkylmethylamine.  
*Use/Production.* (G) Pesticide intermediate. Prod. range: Confidential.

## P 94-30

*Manufacturer.* Confidential.  
*Chemical.* (G) Dialkylmethylamine.  
*Use/Production.* (G) Pesticide intermediate. Prod. range: Confidential.

## P 94-31

*Manufacturer.* Eastman Kodak Company.  
*Chemical.* (G) Polymeric silicone blocked copolymer of substituted alkyl halide and aromatic di-alcohol.  
*Use/Production.* (G) Contained use in an article. Prod. range: 1,500-5,000 kg/yr.

## P 94-32

*Importer.* Arizona Chemical Company.  
*Chemical.* (G) Tall oil alkyd resin.  
*Use/Import.* (G) Formulate coatings for paint and specialty companies. Import range: Confidential.

## P 94-33

*Manufacturer.* Confidential.  
*Chemical.* (G) Modified polyether.  
*Use/Production.* (S) Resin finishing system for cellulosic textile. Prod. range: 4,159-16,636 kg/yr.

## P 94-34

*Manufacturer.* Great Lakes Chemical Corporation.

*Chemical.* (S) 2,4-Imidazolidinedione. bromochloro-5,5-dimethyl.  
*Use/Production.* (G) Residential or commercial cleaner, bleach, or corrosion. Prod. range: Confidential.

## P 94-35

*Manufacturer.* Confidential.  
*Chemical.* (G) Styrene acrylic polyol polymer.  
*Use/Production.* (G) Industrial coating binder component. Prod. range: Confidential.

## P 94-36

*Importer.* Confidential.  
*Chemical.* (G) Mixed sodium/ammonium salt of substituted isophthalic acid.  
*Use/Import.* (G) Dye. Import range: Confidential.

## P 94-37

*Manufacturer.* Dow Corning Corporation.  
*Chemical.* (G) Fluoroalkyl mercaptoalkyl siloxane.  
*Use/Production.* (S) Silicone crosslinker. Prod. range: Confidential.

## P 94-38

*Manufacturer.* Interplastic Corporation.  
*Chemical.* (G) Vinyl ester resin.  
*Use/Production.* (S) Coating and adhesive resin. Prod. range: Confidential.

## P 94-39

*Importer.* Angus Chemical Company.  
*Chemical.* (G) A (4,4-tetramethyl-2-(1-methylethyl)-*N*-(2-methyl-propylidene)-3-oxazolidineethanamine).  
*Use/Import.* (S) Coating resin and adhesive resin. Import range: 50,000-230,000 kg/yr.

## P 94-40

*Manufacturer.* Confidential.  
*Chemical.* (G) Acrylic copolymer.  
*Use/Production.* (G) Open, non-dispersive use. Prod. range: Confidential.

## P 94-41

*Manufacturer.* Confidential.  
*Chemical.* (G) Acrylic copolymer.  
*Use/Production.* (G) Open, non-dispersive use. Prod. range: Confidential.

## P 94-42

*Manufacturer.* Agri Sense Division of Biosys.  
*Chemical.* (S) 3-Hydroxy-1-undecene.  
*Use/Production.* (G) Destructive use. Prod. range: 1,000-10,000 kg/yr.

## P 94-43

*Manufacturer.* Agri Sense Division of Biosys.

Chemical. (S) (E)-4-Tridecenoic acid, ethyl ester.

Use/Production. (G) Destructive use. Prod. range: 1,000-10,000 kg/yr.

**P 94-44**

Manufacturer. 3M Company. Chemical. (G) Polycaprolactone polyurethane.

Use/Production. (G) Coating resin. Prod. range: Confidential.

**P 94-45**

Manufacturer. Polycoat Products Company.

Chemical. (G) Hydrophilic, polyurethane grouping resin.

Use/Production. (S) Hydrophilic polyurethane resin to stop water infiltration. Prod. range: 10,000 kg/yr.

**P 94-46**

Manufacturer. 3M Company.

Chemical. (G) Styrene acrylonitrile polymer.

Use/Production. (G) Coating resin. Prod. range: Confidential.

**P 94-47**

Manufacturer. Confidential. Chemical. (G) Polyurethane.

Use/Production. (S) Isocyanate component of a two part urethane coating system. Prod. range: Confidential.

**P 94-48**

Manufacturer. Confidential.

Chemical. (G) Polyurethane. Use/Production. (S) Isocyanate component of a two part urethane coating system. Prod. range: Confidential.

**P 94-49**

Manufacturer. Confidential.

Chemical. (G) Styrenated acrylate/methacrylate polymer.

Use/Production. (G) Component of dispersively applied coating. Prod. range: 15,000-30,000 kg/yr.

**P 94-50**

Manufacturer. Hercules Incorporated.

Chemical. (G) Oligomeric alkyl ester. Use/Production. (G) Paper making chemical. Prod. range: Confidential.

**P 94-51**

Manufacturer. Hercules Incorporated.

Chemical. (G) Oligomeric alkyl ester. Use/Production. (G) Paper making chemical. Prod. range: Confidential.

**P 94-52**

Manufacturer. Hoechst Celanese Corporation.

Chemical. (G) Substituted aromatic methyl ether.

Use/Production. (S) Captive intermediate. Prod. range: 5,000-10,000 kg/yr.

**P 94-53**

Manufacturer. Hoechst Celanese Corporation.

Chemical. (G) Substituted aromatic methyl ether salt.

Use/Production. (S) Captive intermediate. Prod. range: 5,000-10,000 kg/yr.

**P 94-54**

Manufacturer. Hoechst Celanese Corporation.

Chemical. (G) Trisubstituted naphthalene disulfonic acid salt.

Use/Production. (S) Reactive dye for cellulose. Prod. range: 5,000-25,000 kg/yr.

**P 94-55**

Manufacturer. Hoechst Celanese Corporation.

Chemical. (G) Trisubstituted naphthalene disulfonic acid salt.

Use/Production. (S) Reactive dye for cellulose. Prod. range: 5,000-25,000 kg/yr.

**P 94-56**

Manufacturer. Hoechst Celanese Corporation.

Chemical. (G) Trisubstituted naphthalene disulfonic acid salt.

Use/Production. (S) Reactive dye for cellulose. Prod. range: 5,000-25,000 kg/yr.

**P 94-57**

Manufacturer. Hoechst Celanese Corporation.

Chemical. (G) Trisubstituted naphthalene disulfonic acid salt.

Use/Production. (S) Reactive dye for cellulose. Prod. range: 5,000-25,000 kg/yr.

**P 94-58**

Manufacturer. Hoechst Celanese Corporation.

Chemical. (G) Trisubstituted naphthalene disulfonic acid salt.

Use/Production. (S) Reactive dye for cellulose. Prod. range: 5,000-23,000 kg/yr.

**P 94-59**

Manufacturer. Hoechst Celanese Corporation.

Chemical. (G) Trisubstituted naphthalene disulfonic acid salt.

Use/Production. (S) Reactive dye for cellulose. Prod. range: 5,000-25,000 kg/yr.

**P 94-60**

Importer. Exxon Company.

Chemical. (G) Trisubstituted naphthalene disulfonic acid salt.

Use/Production. (G) Synthetic lubricant basestock. Import. range: Confidential.

**P 94-61**

Manufacturer. Hoechst Celanese Corporation.

Chemical. (G) Trisubstituted naphthalene disulfonic acid salt.

Use/Production. (S) Reactive dye for cellulose. Prod. range: 5,000-25,000 kg/yr.

**P 94-62**

Manufacturer. Confidential.

Chemical. (G) Tertiary amine salt of rosin.

Use/Production. (S) Reactive dye for cellulose. Prod. range: Confidential.

**P 94-63**

Manufacturer. Confidential.

Chemical. (G) Rosin metal salt.

Use/Production. (S) Rosin salt used as tackifier/emulsifier in adhesives. Prod. range: Confidential.

**P 94-64**

Manufacturer. Confidential.

Chemical. (G) Rosin metal salt.

Use/Production. (S) Rosin salt used as tackifier/emulsifier in adhesives. Prod. range: Confidential.

**P 94-65**

Manufacturer. Confidential.

Chemical. (S) Rosin metal salt.

Use/Production. (S) Rosin salt used as tackifier/emulsifier in adhesives. Prod. range: Confidential.

**P 94-66**

Manufacturer. Confidential.

Chemical. (G) Rosin amine.

Use/Production. (S) Rosin salt used as tackifier/emulsifier in adhesives. Prod. range: Confidential.

**P 94-67**

Manufacturer. Confidential.

Chemical. (G) Tertiary amine salt of rosin.

Use/Production. (S) Rosin salt used as tackifier/emulsifier in adhesives. Prod. range: Confidential. I95P 94-68

Manufacturer. Confidential.

Chemical. (G) Tertiary amine salt of rosin.

Use/Production. (S) Rosin salt used as tackifier/emulsifier in adhesives. Prod. range: Confidential.

**P 94-69**

Manufacturer. Confidential.

Chemical. (G) Rosin metal salt.

Use/Production. (S) Rosin salt used as tackifier/emulsifier in adhesives. Prod. range: Confidential.

**P 94-70**

Manufacturer. Confidential.

Chemical. (G) Rosin metal salt.

Use/Production. (S) Rosin salt used as tackifier/emulsifier in adhesives. Prod. range: Confidential.

## P 94-71

*Manufacturer.* Confidential.  
*Chemical.* (G) Tertiary amine salt of rosin.  
*Use/Production.* (S) Rosin salt used as tackifier/emulsifier in adhesives. Prod. range: Confidential.

## P 94-72

*Manufacturer.* Confidential.  
*Chemical.* (G) Rosin amine.  
*Use/Production.* (S) Rosin salt used as tackifier/emulsifier in adhesives. Prod. range: Confidential.

## P 94-73

*Manufacturer.* Ranbar Technology Inc.  
*Chemical.* (G) Chain stopped water reducible alkyd resin.  
*Use/Production.* (S) Component of a coating to be applied to articles of commerce. Prod. range: 100,000–600,000 kg/yr.

## P 94-74

*Importer.* Hoechst Celanese Corporation.  
*Chemical.* (S) Polymer of rosin, paraformaldehydes; calcium hydroxide; and acetic acid.  
*Use/Import.* (S) Printing ink. Import range: Confidential.

## P 94-75

*Manufacturer.* Hercules Incorporated.  
*Chemical.* (G) Alkyl ester.  
*Use/Production.* (G) Papermaking chemical. Prod. range: Confidential.

## P 94-76

*Manufacturer.* Confidential.  
*Chemical.* (G) Phenolic resin.  
*Use/Production.* (G) Metal coatings. Prod. range: Confidential.

## P 94-77

*Importer.* Hoechst Celanese Corporation.  
*Chemical.* (G) Poly(methacrylic-acid)-co-(acrylic-acid)-co-(ethylacrylate)-co-(diallylmaleate)-co-((methacryloyloxyethyl)-carbamate)-co-(alkyl(C<sub>14</sub>-C<sub>18</sub>)-oligoethylene glycol ether crotonate).  
*Use/Import.* (S) Thickener in paint formulations. Import range: 4,000–38,000 kg/yr.

## P 94-78

*Manufacturer.* Confidential.  
*Chemical.* (G) Hydroxylfunctional acrylic polymer.  
*Use/Production.* (S) Coatings. Prod. range: 125,000–208,330 kg/yr.

## P 94-79

*Manufacturer.* Confidential.  
*Chemical.* (G) Hydroxylfunctional acrylic polymer.  
*Use/Production.* (S) Coatings. Prod. range: 125,000–208,330 kg/yr.

## P 94-80

*Manufacturer.* Confidential.  
*Chemical.* (G) Hydroxylfunctional acrylic polymer.  
*Use/Production.* (S) Coatings. Prod. range: 125,000–208,330 kg/yr.

## P 94-81

*Manufacturer.* Confidential.  
*Chemical.* (G) Hydroxylfunctional acrylic polymer.  
*Use/Production.* (S) Coatings. Prod. range: 125,000–208,330 kg/yr.

## P 94-82

*Manufacturer.* Confidential.  
*Chemical.* (G) Hydroxylfunctional acrylic polymer.  
*Use/Production.* (S) Coatings. Prod. range: 125,000–208,330 kg/yr.

## P 94-83

*Manufacturer.* Confidential.  
*Chemical.* (G) Emulsifiable modified diphenylmethane diisocyanate.  
*Use/Production.* (G) Urethane coating component. Prod. range: Confidential.

## P 94-84

*Importer.* Confidential.  
*Chemical.* (G) Meta-substituted benzene.  
*Use/Import.* (G) Destructive use. Import range: Confidential.

## P 94-85

*Manufacturer.* Confidential.  
*Chemical.* (G) Polyurethane.  
*Use/Production.* (S) Isocyanate component of a two part urethane coating system. Prod. range: Confidential.

## P 94-86

*Importer.* Confidential.  
*Chemical.* (G) Polyurethane.  
*Use/Import.* (G) Binder of printing ink. Import range: Confidential.

## P 94-87

*Manufacturer.* Confidential.  
*Chemical.* (G) Dimethylpolysiloxane terpolymer.  
*Use/Production.* (G) Foam control agent and surfactant. Prod. range: Confidential.

## P 94-88

*Importer.* DIC Trading (U.S.A.), Inc.  
*Chemical.* (G) Polythioethersulfone.  
*Use/Import.* (G) Polythioethersulfone copolymer for engineering plastics. Import range: Confidential.

## P 94-89

*Manufacturer.* Confidential.  
*Chemical.* (G) Mixture of reaction products of aliphatic isocyanate; oxirane, methyl-, polymer with oxirane; polyoxy-1,4-butanediyl)-2-hydroxy-

hydroxy; capped with hydroxyethyl acrylate and hydroxyethyl methylacrylate.  
*Use/Production.* (S) Baking for graphic arts printing plate. Prod. range: Confidential.

## P 94-90

*Manufacturer.* Confidential.  
*Chemical.* (G) Polyether polyurethane.  
*Use/Production.* (S) Polymer for coatings, inks, and adhesive formulations. Prod. range: Confidential.

## P 94-91

*Manufacturer.* Angus Chemical Company.  
*Chemical.* (G) Acrylic copolymer.  
*Use/Production.* (S) Chemical process intermediate. Prod. range: Confidential.

## P 94-92

*Manufacturer.* Angus Chemical Company.  
*Chemical.* (G) Aryl substituted alkylamine.  
*Use/Production.* (S) Chemical process intermediate. Prod. range: Confidential.

## P 94-93

*Importer.* Confidential.  
*Chemical.* (G) Saturated polyester resin etherified with bisphenol A.  
*Use/Import.* (G) Raw material for coatings for cans and closures. Import range: Confidential.

## P 94-94

*Importer.* Confidential.  
*Chemical.* (G) Fatty acid modified epoxy resin.  
*Use/Import.* (G) Raw material for use in coating for cans and closures. Import range: Confidential.

## P 94-95

*Manufacturer.* Confidential.  
*Chemical.* (G) Acrylate polyester resin.  
*Use/Production.* (G) Raw material for use in coating for cans and closures. Prod. range: Confidential.

## P 94-96

*Importer.* Confidential.  
*Chemical.* (G) Saturated polyester resin.  
*Use/Import.* (G) Raw material for use in coating for cans and closures. Import range: Confidential.

## P 94-97

*Importer.* Nissho Iwai American Corporation.  
*Chemical.* (S) Lithium hexafluoro phosphate.  
*Use/Import.* (S) Electrolytic salt present in lithium polymer battery. Import range: 3,000–10,000 kg/yr.

## P 94-98

*Manufacturer.* Confidential.

*Chemical.* (G) Cycloalkene-acetic acid, (acetyloxy)-alkyl substituted, alkyl ester.  
*Use/Production.* (S) Site limited intermediate. Prod. range: Confidential.

## P 94-99

*Importer.* Wacker Chemicals (USA), Inc.  
*Chemical.* (G) Sulfonate, carboxylic acid and hydroxyl group containing vinylacetate.

*Use/Import.* (S) Antistatic polyelectrolyte in photographic emulsions rheologic additive in photographic emulsions. Import range: Confidential.

## P 94-100

*Manufacturer.* Confidential.  
*Chemical.* (G) Nonylphenol capped polyurethane prepolymer.  
*Use/Production.* (G) Primer for metals (open non-dispersive use). Prod. range: Confidential.

## P 94-101

*Importer.* Confidential.  
*Chemical.* (G) Substituted isothiazolanthracene.  
*Use/Import.* (G) A dyestuff for fibers. Import range: Confidential.

## P 94-102

*Manufacturer.* Eastman Kodak Company.  
*Chemical.* (G) Dialkylaminophenylimino substituted naphthalene carboxamide.  
*Use/Production.* (G) Contained use in an article. Prod. range: 1,500-7,000 kg/yr.

## P 94-103

*Importer.* Confidential.  
*Chemical.* (G) Fatty acid modified polyester.  
*Use/Import.* (G) Paint additive for open, non-dispersive use. Import range: Confidential.

## P 94-104

*Manufacturer.* Confidential.  
*Chemical.* (G) Copolymer of acrylic methacrylate esters with cyclic vinyl compounds.  
*Use/Production.* (G) Paint additive for open, non-dispersive use. Prod. range: Confidential.

## P 94-105

*Manufacturer.* 3M Company.  
*Chemical.* (G) Substituted succinate hydroxyester.  
*Use/Production.* (G) Structural adhesive. Prod. range: Confidential.

## P 94-106

*Manufacturer.* Strem Chemicals, Inc.  
*Chemical.* (S) Tetrakis(dimethylamino)titanium (IV).

*Use/Production.* (G) Monoelectronics metal film processor (destructive use). Prod. range: Confidential.

## P 94-107

*Manufacturer.* Confidential.  
*Chemical.* (S) Rosin amine salt.  
*Use/Production.* (S) Rosin salt used as tackifier/emulsifier in adhesives. Prod. range: Confidential.

## P 94-108

*Manufacturer.* Confidential.  
*Chemical.* (G) Modified polymethylene polyphenyl isocyanate.  
*Use/Production.* (G) Adhesive. Prod. range: Confidential.

## P 94-109

*Manufacturer.* Confidential.  
*Chemical.* (G) Modified polymethyl polyphenyl isocyanate.  
*Use/Production.* (G) Adhesive. Prod. range: Confidential.

## P 94-110

*Manufacturer.* Confidential.  
*Chemical.* (G) Modified polymethylene polyphenyl isocyanate.  
*Use/Production.* (G) Adhesive. Prod. range: Confidential.

## P 94-111

*Manufacturer.* Confidential.  
*Chemical.* (G) Modified polymethylene polyphenol isocyanate.  
*Use/Production.* (G) Adhesive. Prod. range: Confidential.

## P 94-112

*Manufacturer.* Confidential.  
*Chemical.* (G) 2-Propenamine, copolymer with cationic monomer.  
*Use/Production.* (S) Retention/drainage aide in papermaking and industrial wastewater flocculant. Prod. range: Confidential.

## P 94-113

*Manufacturer.* Confidential.  
*Chemical.* (G) 2-Propenamide, terpolymer with cationic monomers.  
*Use/Production.* (S) Retention/drainage aide in papermaking and industrial waterwaste flocculant. Prod. range: Confidential.

## P 94-115

*Manufacturer.* Texaco Fuel and Marine Marketing Dept.  
*Chemical.* (S) Re-refined vacuum distillate obtained by refining waste oils without hydrotreating, composed of C<sub>20</sub>-C<sub>50</sub> with viscosity.  
*Use/Production.* (S) Asphalt extender. Prod. range: 132mm-165mm kg/yr.

## P 94-116

*Manufacturer.* Henkel Corporation.  
*Chemical.* (S) Titanium catalyst supported on spherical clay beads.

*Use/Production.* (S) Catalyst for esterification. Prod. range: Confidential.

## P 94-117

*Importer.* Confidential.  
*Chemical.* (G) Azo reactive dyestuff.  
*Use/Import.* (G) Open, non-dispersive. Import range: Confidential.

## P 94-118

*Importer.* Confidential.  
*Chemical.* (G) Azo reaction dyestuff.  
*Use/Import.* (G) Open, non-dispersive. Import range: Confidential.

## P 94-119

*Importer.* Confidential.  
*Chemical.* (G) Azo reactive dyestuff.  
*Use/Import.* (G) Open, non-dispersive. Import range: Confidential.

## P 94-120

*Manufacturer.* Confidential.  
*Chemical.* (G) Modified polyacrylic in 2-butanol.  
*Use/Production.* (G) Paint additive for open, non-dispersive use. Prod. range: Confidential.

## P 94-121

*Manufacturer.* Confidential.  
*Chemical.* (G) Modified polyacrylate in cryanic solvent.  
*Use/Production.* (G) Paint additive for open, non-dispersive use. Prod. range: Confidential.

## P 94-122

*Manufacturer.* Confidential.  
*Chemical.* (G) Phosphinic acid.  
*Use/Production.* (G) Chemical reactant having a destructive use. Prod. range: 425-600 kg/yr.

## P 94-123

*Importer.* Confidential.  
*Chemical.* (G) Hydroxyfunctional acrylatic polymer.  
*Use/Import.* (G) Automotive refinish exterior coating. Import range: Confidential.

## P 94-124

*Manufacturer.* DIC Training (USA), Inc.  
*Chemical.* (G) Anionic fluoro surface agent.  
*Use/Import.* (G) Surface active agent. Prod. range: Confidential.

## P 94-125

*Importer.* Mitsui Petrochemicals (America), Ltd.  
*Chemical.* (G) Hydrocarbons, C<sub>4-8</sub>, C<sub>5</sub>-rich polymer with aromatic hydrocarbons.  
*Use/Import.* (G) Material for adhesives. Import range: Confidential.

## P 94-126

*Importer.* Mitsui Petrochemicals (America), Ltd.

*Chemical.* (G) Hydrocarbons, C<sub>4</sub>-<sub>8</sub>, C<sub>5</sub>-rich polymer with aromatic.  
*Use/Import.* (G) Material for adhesives. Import range: Confidential.

## P 94-127

*Manufacturer.* DuPont Company.  
*Chemical.* (G) Amine salt of alkyd alcohols/P205 reaction products.  
*Use/Production.* (G) Metal surface treatment. Prod. range: Confidential.

## P 94-128

*Manufacturer.* Confidential.  
*Chemical.* (G) Hydroxy functional styrene acrylic copolymer.  
*Use/Production.* (G) Highly dispersive use. Prod. range: Confidential.

## P 94-129

*Manufacturer.* Confidential.  
*Chemical.* (G) Hydroxy functional styrene/acrylic polymer.  
*Use/Production.* (G) Highly dispersive use. Prod. range: Confidential.

## P 94-130

*Manufacturer.* E. I. du Pont de Nemours & Company, Inc.  
*Chemical.* (G) Copolyester.  
*Use/Production.* (G) General purpose molding resin. Prod. range: Confidential.

## P 94-131

*Manufacturer.* Confidential.  
*Chemical.* (G) Mixture of carboxylic acids, esters, alcohols, hydrocarbons.  
*Use/Production.* (G) Feedstock for lubricant base oils; destructive use. Prod. range: Confidential.

## P 94-132

*Manufacturer.* Confidential.  
*Chemical.* (S) Organosilane alkoxy ester.  
*Use/Production.* (G) Component of adhesive formulation. Prod. range: Confidential.

## P 94-133

*Importer.* Baerlocher USA/Joint Venture.  
*Chemical.* (S) Stannane, dibutylbis (1-oxoisooctadecyl), oxy.  
*Use/Import.* (S) Stabilizer for PVC foam. Import range: 400-1,000 kg/yr.

## P 94-134

*Importer.* Confidential.  
*Chemical.* (G) Copper hexacyanoferrate of xanthene dyestuff.  
*Use/Import.* (G) Open, non-dispersive. Import range: Confidential.

## P 94-135

*Manufacturer.* E. I. du Pont de Nemours & Company, Inc.  
*Chemical.* (G) Hydroxyarylsulfone condensation polymers.

*Use/Production.* (G) Topical finish for textile. Prod. range: Confidential.

## P 94-136

*Manufacturer.* Ciba-Geigy Corporation.  
*Chemical.* (S) Benzenepropanoic acid, 3,5-bis (1,1-dimethylethyl)-4-hydroxy-, methyl ester, reaction product with sodium hydrogen sulfate.  
*Use/Production.* (S) Intermediate. Prod. range: Confidential.

## P 94-137

*Importer.* Ciba Geigy Corporation.  
*Chemical.* (G) Sulfonated copper phthalocyanine derivative, amine salt.  
*Use/Import.* (G) Paper dye. Import range: Confidential.

## P 94-138

*Manufacturer.* Eastman Chemical Company.  
*Chemical.* (S) Ethanol, 2-(2-(2-propoxyethoxy)ethoxy)-.  
*Use/Production.* (S) Component of brake fluid. Prod. range: Confidential.

## P 94-139

*Manufacturer.* Confidential.  
*Chemical.* (G) Modified acrylic polymer.  
*Use/Production.* (G) Open, non-dispersive use. Prod. range: Confidential.

## P 94-140

*Manufacturer.* Minnesota Mining & Manufacturing Company.  
*Chemical.* (G) Polyepichlorohydrin derivative.  
*Use/Production.* (S) Chemical intermediate. Prod. range: Confidential.

## P 94-141

*Manufacturer.* Minnesota Mining & Manufacturing Company.  
*Chemical.* (G) Polyepichlorohydrin diol.  
*Use/Production.* (S) Chemical intermediate. Prod. range: Confidential.

## P 94-142

*Manufacturer.* Minnesota Mining & Manufacturing Company.  
*Chemical.* (G) Glycidal azide polymers.  
*Use/Production.* (G) Binder. Prod. range: Confidential.

## P 94-143

*Manufacturer.* Minnesota Mining & Manufacturing Company.  
*Chemical.* (G) Glycidal azide polymers.  
*Use/Production.* (G) Binder. Prod. range: Confidential.

## P 94-144

*Importer.* Confidential.

*Chemical.* (G) Fluorinated acrylic copolymer.  
*Use/Import.* (G) Oil and water proofing agent. Import range: Confidential.

## P 94-145

*Manufacturer.* Courtaulds Aerospace.  
*Chemical.* (G) Epoxy resin alkylated phenolic polyamine adduct.  
*Use/Production.* (S) Curing agent for epoxy based paints. Prod. range: Confidential.

## P 94-146

*Manufacturer.* Confidential.  
*Chemical.* (G) Modified maleated rosin salts.  
*Use/Production.* (S) Intermediates in the manufacture of modified maleated. Prod. range: Confidential.

## P 94-147

*Manufacturer.* Confidential.  
*Chemical.* (G) Modified maleated rosin salts.  
*Use/Production.* (S) The PMN substances function as isolated chemical intermediates in the manufacture of modified maleated. Prod. range: Confidential.

## P 94-148

*Manufacturer.* Confidential.  
*Chemical.* (G) Modified maleated rosin salts.  
*Use/Production.* (S) The PMN substances function as isolated chemical intermediates in the manufacture of modified maleated. Prod. range: Confidential.

## P 94-149

*Manufacturer.* Confidential.  
*Chemical.* (G) Modified maleated rosin salts.  
*Use/Production.* (S) The PMN substances function as isolated chemical intermediates in the manufacture of modified maleated. Prod. range: Confidential.

## P 94-150

*Manufacturer.* Confidential.  
*Chemical.* (G) Modified maleated rosin salts.  
*Use/Production.* (S) The PMN substances function as isolated chemical intermediates in the manufacture of modified maleated. Prod. range: Confidential.

## P 94-151

*Manufacturer.* Confidential.  
*Chemical.* (G) Modified maleated rosin salts.  
*Use/Production.* (S) The PMN substances function as isolated chemical intermediates in the manufacture of modified maleated. Prod. range: Confidential.







**Chemical.** (G) Modified maleated rosin, calcium salt.

**Use/Production.** (S) The PMN substances function as binders in publication gravure printing inks. Prod. range: Confidential.

P 94-197

**Manufacturer.** Confidential.

**Chemical.** (G) Modified maleated rosin, calcium salt.

**Use/Production.** (S) The PMN substances function as binders in publication gravure printing inks. Prod. range: Confidential.

P 94-198

**Manufacturer.** Confidential.

**Chemical.** (G) Modified maleated rosin, calcium salt.

**Use/Production.** (S) The PMN substances function as binders in publication gravure printing inks. Prod. range: Confidential.

P 94-199

**Manufacturer.** Confidential.

**Chemical.** (G) Modified maleated rosin, calcium salt.

**Use/Production.** (S) The PMN substances function as binders in publication gravure printing inks. Prod. range: Confidential.

P 94-200

**Manufacturer.** Confidential.

**Chemical.** (G) Modified maleated rosin, calcium salt.

**Use/Production.** (S) The PMN substances function as binders in publication gravure printing inks. Prod. range: Confidential.

#### List of Subjects

Environmental protection,  
Premanufacture notification.

Dated: April 7, 1994.

Frank V. Caesar,

Acting Director, Information Management Division, Office of Pollution Prevention and Toxics.

[FR Doc. 94-9291 Filed 4-15-94; 8:45 am]

BILLING CODE 6560-50-F

#### FEDERAL COMMUNICATIONS COMMISSION

[Report No. 2004]

#### Petitions for Reconsideration of Actions in Rulemaking Proceedings

April 13, 1994.

Petitions for reconsiderations and clarifications have been filed in the Commission rulemaking proceedings listed in this Public Notice and published pursuant to 47 CFR 1.429(e). The full text of these documents are

available for viewing and copying in room 239, 1919 M Street, NW., Washington, DC or may be purchased from the Commission's copy contractor, ITS, Inc. (202) 857-3800. Opposition to these petitions must be filed May 3, 1994. See § 1.4(b)(1) of the Commission's rules (47 CFR 1.4(b)(1)). Replies to an opposition must be filed within 10 days after the time for filing oppositions has expired.

Subject: Transport Rate Structure and Pricing.

Number of Petitions Filed: 3.

Federal Communications Commission.

William F. Caton,

Acting Secretary.

[FR Doc. 94-9258 Filed 4-15-94; 8:45 am]

BILLING CODE 6712-01-M

#### FEDERAL DEPOSIT INSURANCE CORPORATION

##### Privacy Act of 1974; Amendment to an Existing System of Records

**AGENCY:** Federal Deposit Insurance Corporation (FDIC).

**ACTION:** Notice of amendment to an existing system of records—"Insured Bank Liquidation Records System".

**SUMMARY:** As part of an ongoing examination of the FDIC's systems of records, the Insured Bank Liquidation Records System has been reviewed for compliance with the Privacy Act of 1974, 5 U.S.C. 552a. Minor amendments have been made that will more accurately describe the following categories in this system or records: system location, retrievability, and system manager(s) and address.

**EFFECTIVE DATE:** April 18, 1994.

**FOR FURTHER INFORMATION CONTACT:**

Frederick N. Ottie, Attorney, FDIC, 550-17th Street NW., Washington, DC 20429, (202) 898-6679.

**SUPPLEMENTARY INFORMATION:** The FDIC's system of records entitled "Insured Bank Liquidation Records System" is being amended to more accurately describe its contents. These modifications update descriptions in the system location as well as the system manager and address categories to reflect organizational changes within the FDIC. The retrievability category adds the use of financial institution numbers to facilitate retrieval of records in this system.

Accordingly, the Board of Directors of the FDIC amends the "Insured Bank Liquidation Records System" to read as follows:

**FDIC 30-64-0013**

#### SYSTEM NAME:

Insured Bank Liquidation Records System. (Complete text appears at 53 FR 12816, April 19, 1988; amended at 53 FR 23309, June 21, 1988).

#### SYSTEM LOCATION:

Designated FDIC service centers, consolidated field offices, and sites of failed FDIC-insured institutions. A list of the designated locations is available from the Chief of Policy and Planning, Operations Branch, Division of Depositor and Asset Services, FDIC, 550-17th Street NW., Washington, DC 20429.

\* \* \* \* \*

#### POLICIES AND PRACTICES FOR STORING, RETRIEVING, ACCESSING, RETAINING, AND DISPOSING OF RECORDS IN THE SYSTEM:

\* \* \* \* \*

#### RETRIEVABILITY:

Indexed by financial institution number, name of failed or assisted insured institution, and by name of individual.

\* \* \* \* \*

#### SYSTEM MANAGER(S) AND ADDRESS:

The appropriate FDIC regional director for records maintained in FDIC service centers, consolidated field offices, and sites of failed FDIC-insured institutions.

\* \* \* \* \*

By direction of the Board of Directors.

Dated at Washington, DC, this 12th day of April, 1994.

Federal Deposit Insurance Corporation.

Robert E. Feldman,

Acting Executive Secretary.

[FR Doc. 94-9277 Filed 4-17-94; 8:45 am]

BILLING CODE 6714-01-P

#### FEDERAL RESERVE SYSTEM

##### First Midwest Corporation of Delaware; Notice of Application To Engage de novo in Permissible Nonbanking Activities

The company listed in this notice has filed an application under § 225.23(a)(1) of the Board's Regulation Y (12 CFR 225.23(a)(1)) for the Board's approval under section 4(c)(8) of the Bank Holding Company Act (12 U.S.C. 1843(c)(8)) and § 225.21(a) of Regulation Y (12 CFR 225.21(a)) to commence or to engage *de novo*, either directly or through a subsidiary, in a nonbanking activity that is listed in § 225.25 of Regulation Y as closely related to banking and permissible for bank

holding companies. Unless otherwise noted, such activities will be conducted throughout the United States.

The application is available for immediate inspection at the Federal Reserve Bank indicated. Once the application has been accepted for processing, it will also be available for inspection at the offices of the Board of Governors. Interested persons may express their views in writing on the question whether consummation of the proposal can "reasonably be expected to produce benefits to the public, such as greater convenience, increased competition, or gains in efficiency, that outweigh possible adverse effects, such as undue concentration of resources, decreased or unfair competition, conflicts of interests, or unsound banking practices." Any request for a hearing on this question must be accompanied by a statement of the reasons a written presentation would not suffice in lieu of a hearing, identifying specifically any questions of fact that are in dispute, summarizing the evidence that would be presented at a hearing, and indicating how the party commenting would be aggrieved by approval of the proposal.

Comments regarding the application must be received at the Reserve Bank indicated or the offices of the Board of Governors not later than May 9, 1994.

**A. Federal Reserve Bank of Chicago** (James A. Bluemle, Vice President) 230 South LaSalle Street, Chicago, Illinois 60690:

1. *First Midwest Corporation of Delaware*, Melrose Park, Illinois; to engage *de novo* through its subsidiary Midwest Trust Services, Inc., Elmwood Park, Illinois, in accepting and executing trusts and carrying on a general trust company business pursuant to § 225.25(b)(3) of the Board's Regulation Y. These activities are intended to serve the Chicago metropolitan area including Cook, Lake, Will, DuPage and McHenry Counties.

Board of Governors of the Federal Reserve System, April 12, 1994.

Jennifer J. Johnson,

Associate Secretary of the Board.

[FR Doc. 94-9238 Filed 4-15-94; 8:45 am]

BILLING CODE 6210-01-F

#### Keystone Financial, Inc., et al.; Formations of; Acquisitions by; and Mergers of Bank Holding Companies

The companies listed in this notice have applied for the Board's approval under section 3 of the Bank Holding Company Act (12 U.S.C. 1842) and § 225.14 of the Board's Regulation Y (12

CFR 225.14) to become a bank holding company or to acquire a bank or bank holding company. The factors that are considered in acting on the applications are set forth in section 3(c) of the Act (12 U.S.C. 1842(c)).

Each application is available for immediate inspection at the Federal Reserve Bank indicated. Once the application has been accepted for processing, it will also be available for inspection at the offices of the Board of Governors. Interested persons may express their views in writing to the Reserve Bank or to the offices of the Board of Governors. Any comment on an application that requests a hearing must include a statement of why a written presentation would not suffice in lieu of a hearing, identifying specifically any questions of fact that are in dispute and summarizing the evidence that would be presented at a hearing.

Unless otherwise noted, comments regarding each of these applications must be received not later than May 12, 1994.

**A. Federal Reserve Bank of Philadelphia** (Thomas K. Desch, Vice President) 100 North 6th Street, Philadelphia, Pennsylvania 19105:

1. *Keystone Financial, Inc.*, Harrisburg, Pennsylvania; to merge with The Frankford Corporation, Philadelphia, Pennsylvania, and thereby indirectly acquire Frankford Trust Company, Philadelphia, Pennsylvania.

**B. Federal Reserve Bank of Richmond** (Lloyd W. Bostian, Jr., Senior Vice President) 701 East Byrd Street, Richmond, Virginia 23261:

1. *City Holding Company*, Charleston, West Virginia; to acquire 100 percent of the voting shares of Lincoln Savings Bank, Carnegie, Pennsylvania.

**C. Federal Reserve Bank of Chicago** (James A. Bluemle, Vice President) 230 South LaSalle Street, Chicago, Illinois 60690:

1. *Heritage Financial Services, Inc.*, Tinley Park, Illinois; to acquire 100 percent of the voting shares of Midlothian State Bank, Midlothian, Illinois.

2. *The Second Fourth Street Financial Corp.*, Pekin, Illinois; to become a bank holding company by acquiring 100 percent of the voting shares of Herget Financial Corp., Pekin, Illinois; and thereby indirectly acquire The Herget National Bank of Pekin, Pekin, Illinois.

**D. Federal Reserve Bank of Minneapolis** (James M. Lyon, Vice President) 250 Marquette Avenue, Minneapolis, Minnesota 55480:

1. *G.B. Financial Services, Inc.*, Greenbush, Minnesota; to become a bank holding company by acquiring 60

percent of the voting shares of Greenbush Bancshares, Inc., Greenbush, Minnesota, and thereby indirectly acquire Greenbush State Bank, Greenbush, Minnesota.

**E. Federal Reserve Bank of Dallas** (Genie D. Short, Vice President) 2200 North Pearl Street, Dallas, Texas 75201-2272:

1. *First Bancorp, Inc.*, Denton, Texas; to acquire 100 percent of the voting shares of Bedford National Bank, Bedford, Texas.

2. *First Delaware Bancorp, Inc.*, Dover, Delaware; to acquire 100 percent of the voting shares of Bedford National Bank, Bedford, Texas.

3. *Texas Financial Bancorporation, Inc.*, Minneapolis, Minnesota; to acquire 100 percent of the voting shares of Bedford National Bank, Bedford, Texas.

**F. Federal Reserve Bank of San Francisco** (Kenneth R. Binning, Director, Bank Holding Company) 101 Market Street, San Francisco, California 94105:

1. *First Commercial Bank*, Taipei, Taiwan; to become a bank holding by acquiring 100 percent of the voting shares of FCB Taiwan California Bank, San Gabriel Valley, California, a *de novo* bank.

Board of Governors of the Federal Reserve System, April 12, 1994.

Jennifer J. Johnson,

Associate Secretary of the Board.

[FR Doc. 94-9239 Filed 4-15-94; 8:45 am]

BILLING CODE 6210-01-F

#### Jack A. and Tom E. Marantz; Change in Bank Control Notice

#### Acquisition of Shares of Banks or Bank Holding Companies

The notificant listed below has applied under the Change in Bank Control Act (12 U.S.C. 1817(j)) and § 225.41 of the Board's Regulation Y (12 CFR 225.41) to acquire a bank or bank holding company. The factors that are considered in acting on notices are set forth in paragraph 7 of the Act (12 U.S.C. 1817(j)(7)).

The notice is available for immediate inspection at the Federal Reserve Bank indicated. Once the notice has been accepted for processing, it will also be available for inspection at the offices of the Board of Governors. Interested persons may express their views in writing to the Reserve Bank indicated for the notice or to the offices of the Board of Governors. Comments must be received not later than May 9, 1994.

**A. Federal Reserve Bank of Chicago** (James A. Bluemle, Vice President) 230

South LaSalle Street, Chicago, Illinois 60690:

1. *Jack A. and Tom E. Marantz*, Springfield, Illinois; to acquire 27.74 percent of the voting shares of Spring Bancorp, Inc., Springfield, Illinois, and thereby indirectly acquire Bank of Springfield, Springfield, Illinois.

Board of Governors of the Federal Reserve System, April 12, 1994.

Jennifer J. Johnson,

Associate Secretary of the Board.

[FR Doc. 94-9240 Filed 4-15-94; 8:45 am]

BILLING CODE 6210-01-F

### Mellon Bank Corporation; Acquisition of Company Engaged in Permissible Nonbanking Activities

The organization listed in this notice has applied under § 225.23(a)(2) or (f) of the Board's Regulation Y (12 CFR 225.23(a)(2) or (f)) for the Board's approval under section 4(c)(8) of the Bank Holding Company Act (12 U.S.C. 1843(c)(8)) and § 225.21(a) of Regulation Y (12 CFR 225.21(a)) to acquire or control voting securities or assets of a company engaged in a nonbanking activity that is listed in § 225.25 of Regulation Y as closely related to banking and permissible for bank holding companies. Unless otherwise noted, such activities will be conducted throughout the United States.

The application is available for immediate inspection at the Federal Reserve Bank indicated. Once the application has been accepted for processing, it will also be available for inspection at the offices of the Board of Governors. Interested persons may express their views in writing on the question whether consummation of the proposal can "reasonably be expected to produce benefits to the public, such as greater convenience, increased competition, or gains in efficiency, that outweigh possible adverse effects, such as undue concentration of resources, decreased or unfair competition, conflicts of interests, or unsound banking practices." Any request for a hearing on this question must be accompanied by a statement of the reasons a written presentation would not suffice in lieu of a hearing, identifying specifically any questions of fact that are in dispute, summarizing the evidence that would be presented at a hearing, and indicating how the party commenting would be aggrieved by approval of the proposal.

Comments regarding the application must be received at the Reserve Bank indicated or the offices of the Board of Governors not later than May 3, 1994.

A. Federal Reserve Bank of Cleveland (John J. Wixted, Jr., Vice President) 1455 East Sixth Street, Cleveland, Ohio 44101:

1. *Mellon Bank Corporation*, Pittsburgh, Pennsylvania; to acquire 100 percent of the voting shares of Belden and Associates Investment Counsel, San Francisco, California, and thereby engage in investment advisory services pursuant to § 225.25(b)(4) of the Board's Regulation Y.

Board of Governors of the Federal Reserve System, April 12, 1994.

Jennifer J. Johnson,

Associate Secretary of the Board.

[FR Doc. 94-9241 Filed 4-15-94; 8:45 am]

BILLING CODE 6210-01-F

## DEPARTMENT OF HEALTH AND HUMAN SERVICES

### Agency for Health Care Policy and Research

#### Meeting of the National Advisory Council for Health Care Policy, Research, and Evaluation

AGENCY: Agency for Health Care Policy and Research, HHS.

ACTION: Notice of public meeting.

SUMMARY: In accordance with section 10(a) of the Federal Advisory Committee Act, this notice announces a meeting of the National Advisory Council for Health Care Policy, Research, and Evaluation.

DATES: The meeting will be open to the public on Tuesday, May 17, 1994, from 9:30 a.m. to 3 p.m.

In accordance with the provisions set forth in section 552b(c)(6), title 5, U.S. Code, and section 10(d) of the Federal Advisory Committee Act, a meeting closed to the public will be held on May 17, 1994, from 3:15 p.m. to 5 p.m. to review, discuss, and evaluate grant applications. The discussion and review of grant applications could reveal confidential personal information, the disclosure of which would constitute a clearly unwarranted invasion of personal privacy.

ADDRESSES: The meeting will be held at the Madison Hotel, 1177 15th Street NW., Washington, DC 20005.

FOR FURTHER INFORMATION CONTACT: Deborah L. Queenan, Executive Secretary of the Advisory Council at the Agency for Health Care Policy and Research, 2101 East Jefferson Street Suite 603, Rockville, Maryland 20852, (301) 594-1459.

In addition, if sign language interpretation or other reasonable

accommodation for a disability is needed, please contact Linda Reeves, the Assistant Administrator for Equal Opportunity, AHCP, on (301) 594-6666 no later than May 2, 1994.

### SUPPLEMENTARY INFORMATION:

#### I. Purpose

Section 921 of the Public Health Service Act (42 U.S.C. 299c) establishes the National Advisory Council for Health Care Policy, Research, and Evaluation. The Council provides advice to the Secretary and the Administrator, Agency for Health Care Policy and Research (AHCP), on matters related to the activity of AHCP to enhance the quality, appropriateness, and effectiveness of health care services and access to such services through scientific research and the promotion of improvements in clinical practice and the organization, financing, and delivery of health care services.

The Council is composed of public members appointed by the Secretary. These members are:

Linda H. Aiken, Ph.D.; Edward C. Bessey, M.B.A.; Marian F. Bishop, Ph.D.; Linda Burnes Bolton, Dr.P.H.; Joseph T. Curti, M.D.; John W. Danaher, M.D.; David E. Hayes-Bautista, Ph.D.; William S. Kiser, M.D.; Kermit B. Knudsen, M.D.; Norma M. Lang, Ph.D.; Barbara J. McNeil, M.D., Ph.D.; Walter J. McNeerney, M.H.A.; Lawrence H. Meskin, D.D.S., Ph.D.; Theodore J. Phillips, M.D.; Louis F. Rossiter, Ph.D.; Barbara Starfield, M.D.; and Donald E. Wilson, M.D.

There also are Federal ex officio Members. These members are:

Administrator, Substance Abuse and Mental Health Services Administration; Director, National Institutes of Health; Director, Centers for Disease Control and Prevention; Administrator, Health Care Financing Administration; Commissioner, Food and Drug Administration; Assistant Secretary of Defense (Health Affairs); and Chief Medical Director, Department of Veterans Affairs.

#### II. Agenda

On Tuesday, May 17, 1994, the open portion of the meeting will begin at 9:30 a.m. with the call to order by the Council Chairman, Philip R. Lee, M.D., Assistant Secretary for Health, Department of Health and Human Services will address the Council on the future of the Public Health Service and Health Care Reform. The Administrator, AHCP, will conclude the morning meeting with an update on AHCP activities.

In the afternoon the Council will discuss Health Care Reform and the role of AHCPR. The open meeting will adjourn at 3 p.m. The Council will begin the closed portion of the meeting to review grant applications from 3:15 p.m. to 5 p.m. The meeting will then adjourn at 5 p.m.

Agenda items are subject to change as priorities dictate.

Dated: April 11, 1994.

**J. Jarrett Clinton,**

*Administrator,*

[FR Doc. 94-9306 Filed 4-15-94; 8:45 am]

BILLING CODE 4160-90-P

### Administration on Aging

#### Public Information Collection Requirements Submitted to the Office of Management and Budget (OMB) for Clearance

**AGENCY:** Administration on Aging, HHS.

The Administration on Aging (AoA), Department of Health and Human Services, has submitted to the Office of Management and Budget (OMB) the following proposal for the collection of information in compliance with the Paperwork Reduction Act (Public Law 96-511).

*Title of Information Collection:* Elderly Nutrition Program Evaluation.

*Type of Request:* New.

*Use:* To describe the characteristics of participants in nutrition programs under the Older Americans Act, assess the impact of the program on participants, determine the efficiency of the program's administrative and service delivery elements, and to assess funding sources and adequacy, based on data collected from organizations in the aging network, elderly participants, and non-participants, monitor program operations, growth and results of Title VI funded activities, and to provide information for responses to inquiries.

*Frequency:* One time.

*Respondents:* State and local officials, service providers, program participants and non-participants.

*Estimated Number of Responses:* 8300.

*Total Estimated Burden Hours:* 6,257.

*Additional Information or Comments:* Contact David Bunoski of the Executive Secretariat in the Administration on Aging on (202) 260-0669 for further information. Written comments and recommendations for the proposed information collection should be sent directly to the following address: OMB Reports Management Branch, Attention: Allison Eyd, New Executive Office Building, room 3208, Washington, DC 20503.

Dated: April 11, 1994.

**Fernando M. Torres-Gil,**

*Assistant Secretary for Aging,*

[FR Doc. 94-9185 Filed 4-15-94; 8:45 am]

BILLING CODE 4150-04-U

### Food and Drug Administration

[Docket No. 94F-0090]

#### Shell Oil Co.; Filing of Food Additive Petition

**AGENCY:** Food and Drug Administration, HHS.

**ACTION:** Notice.

**SUMMARY:** The Food and Drug Administration (FDA) is announcing that Shell Oil Co. has filed a petition proposing that the food additive regulations be amended to provide broadened specifications for congealing point and oil content for synthetic paraffinic waxes produced by the Fischer-Tropsch process to more closely resemble specifications for other synthetic paraffinic waxes permitted for use in food packaging under other regulations.

**DATES:** Written comments on the petitioner's environmental assessment by May 18, 1994.

**ADDRESSES:** Submit written comments to the Dockets Management Branch (HFA-305), Food and Drug Administration, rm. 1-23, 12420 Parklawn Dr., Rockville, MD 20857.

**FOR FURTHER INFORMATION CONTACT:** Mitchell A. Cheeseman, Center for Food Safety and Applied Nutrition (HFS-216), Food and Drug Administration, 200 C St. SW., Washington, DC 20204, 202-254-9511.

**SUPPLEMENTARY INFORMATION:** Under the Federal Food, Drug, and Cosmetic Act (sec. 409(b)(5) (21 U.S.C. 348(b)(5))), notice is given that a food additive petition (FAP 4B4416) has been filed by Shell Oil Co., One Shell Plaza, P.O. Box 4320, Houston, TX 77210. The petition proposes to amend the food additive regulations in § 175.250 *Paraffin (synthetic)* (21 CFR 175.250) to incorporate broadened specifications for congealing point and oil content for synthetic paraffinic waxes produced by the Fischer-Tropsch process to more closely resemble specifications for other synthetic paraffinic waxes permitted for use in food packaging under other regulations.

The potential environmental impact of this action is being reviewed. To encourage public participation consistent with regulations promulgated under the National Environmental Policy Act, (40 CFR 1501.4 (b)), the

agency is placing the environmental assessment submitted with the petition that is the subject of this notice on public display at the Dockets Management Branch (address above) for public review and comment. Interested persons may, on or before May 18, 1994, submit to the Dockets Management Branch (address above) written comments. Two copies of any comments are to be submitted, except that individuals may submit one copy. Comments are to be identified with the docket number found in brackets in the heading of this document. Received comments may be seen in the office above between 9 a.m. and 4 p.m., Monday through Friday. FDA will also place on public display any amendments to, or comments on, the petitioner's environmental assessment without further announcement in the **Federal Register**. If, based on its review, the agency finds that an environmental impact statement is not required and this petition results in a regulation, the notice of availability of the agency's finding of no significant impact and the evidence supporting that finding will be published with the regulation in the **Federal Register** in accordance with 21 CFR 25.40(c).

Dated: April 6, 1994.

**Fred R. Shank,**

*Director, Center for Food Safety and Applied Nutrition.*

[FR Doc. 94-9191 Filed 4-15-94; 8:45 am]

BILLING CODE 4160-01-F

[Docket No. 94M-0062]

#### DePuy, Inc.; Premarket Approval of the Rotating Platform Configuration of the New Jersey LCS® Total Knee System

**AGENCY:** Food and Drug Administration, HHS.

**ACTION:** Notice.

**SUMMARY:** The Food and Drug Administration (FDA) is announcing its approval of the application by DePuy, Inc., Warsaw, IN, for premarket approval, under section 515 of the Federal Food, Drug, and Cosmetic Act (the act), of the Rotating Platform Configuration of the new jersey LCS® Total Knee System. After reviewing the recommendation of the Orthopedic and Rehabilitation Devices Panel, FDA's Center for Devices and Radiological Health (CDRH) notified the applicant, by letter of February 24, 1994, of the approval of the application.

**DATES:** Petitions for administrative review by May 18, 1994.

**ADDRESSES:** Written requests for copies of the summary of safety and

effectiveness data and petitions for administrative review to the Dockets Management Branch (HFA-305), Food and Drug Administration, rm. 1-23, 12420 Parklawn Dr., Rockville, MD 20857.

**FOR FURTHER INFORMATION CONTACT:** Paul R. Beninger, Center for Devices and Radiological Health (HFZ-410), Food and Drug Administration, 1390 Piccard Dr., Rockville, MD 20850, 301-594-1184.

**SUPPLEMENTARY INFORMATION:** On April 26, 1991, DePuy, Inc., Warsaw, IN 46581-0988, submitted to CDRH an application for premarket approval of the Rotating Platform Configuration of the new jersey LCS® Total Knee System. The device is indicated for uncemented use in skeletally mature individuals undergoing primary surgery for rehabilitating knees damaged as a result of noninflammatory degenerative joint disease (NIDJD) or either of its composite diagnoses of osteoarthritis or post-traumatic arthritis. It is indicated for use in knees whose anterior and posterior cruciate ligaments are absent or are in such condition as to justify sacrifice.

On November 22, 1991, the Orthopedic and Rehabilitation Devices Panel of the Medical Devices Advisory Committee, an FDA advisory committee, reviewed and recommended approval of the application. On February 24, 1994, CDRH approved the application by a letter to the applicant from the Director of the Office of Device Evaluation, CDRH.

A summary of the safety and effectiveness data on which CDRH based its approval is on file in the Dockets Management Branch (address above) and is available from that office upon written request. Requests should be identified with the name of the device and the docket number found in brackets in the heading of this document.

#### Opportunity for Administrative Review

Section 515(d)(3) of the act (21 U.S.C. 360e(d)(3)) authorizes any interested person to petition, under section 515(g) of the act (21 U.S.C. 360e(g)), for administrative review of CDRH's decision to approve this application. A petitioner may request either a formal hearing under part 12 (21 CFR part 12) of FDA's administrative practices and procedures regulations or a review of the application and CDRH's action by an independent advisory committee of experts. A petition is to be in the form of a petition for reconsideration under § 10.33(b) (21 CFR 10.33(b)). A petitioner shall identify the form of

review requested (hearing or independent advisory committee) and shall submit with the petition supporting data and information showing that there is a genuine and substantial issue of material fact for resolution through administrative review. After reviewing the petition, FDA will decide whether to grant or deny the petition and will publish a notice of its decision in the **Federal Register**. If FDA grants the petition, the notice will state the issue to be reviewed, the form of review to be used, the persons who may participate in the review, the time and place where the review will occur, and other details.

Petitioners may, at any time on or before May 18, 1994, file with the Dockets Management Branch (address above) two copies of each petition and supporting data and information, identified with the name of the device and the docket number found in brackets in the heading of this document. Received petitions may be seen in the office above between 9 a.m. and 4 p.m., Monday through Friday.

This notice is issued under the Federal Food, Drug, and Cosmetic Act (secs. 515(d), 520(h) (21 U.S.C. 360e(d), 360j(h))) and under authority delegated to the Commissioner of Food and Drugs (21 CFR 5.10) and redelegated to the Director, Center for Devices and Radiological Health (21 CFR 5.53).

Dated: April 5, 1994.

Joseph A. Levitt,  
Deputy Director for Regulations Policy, Center  
for Devices and Radiological Health.

[FR Doc. 94-9307 Filed 4-15-94; 8:45 am]

BILLING CODE 4150-01-F

[Docket No. 94M-0037]

#### CIBA Vision Corp.; Premarket Approval of the NDS System

**AGENCY:** Food and Drug Administration, HHS.

**ACTION:** Notice.

**SUMMARY:** The Food and Drug Administration (FDA) is announcing its approval of the application by CIBA Vision Corp., Duluth, GA, for premarket approval, under section 515 of the Federal Food, Drug, and Cosmetic Act (the act), of the NDS System. After reviewing the recommendation of the Ophthalmic Devices Panel, FDA's Center for Devices and Radiological Health (CDRH) notified the applicant by letter of January 10, 1994, of the approval of the application.

**DATES:** Petitions for administrative review by May 18, 1994.

**ADDRESSES:** Written requests for copies of the summary of safety and effectiveness data and petitions for administrative review to the Dockets Management Branch (HFA-305), Food and Drug Administration, rm. 1-23, 12420 Parklawn Dr., Rockville, MD 20857.

**FOR FURTHER INFORMATION CONTACT:** James F. Saviola, Center for Devices and Radiological Health (HFZ-460), Food and Drug Administration, 1390 Piccard Dr., Rockville, MD 20850, 301-594-1744.

**SUPPLEMENTARY INFORMATION:** On April 9, 1990, CIBA Vision Corp., Duluth, GA 30136-1518, submitted to CDRH an application for premarket approval of the NDS System. The system consists of the NDS Starting Solution and the NDS Finishing Solution. The NDS System is indicated for the cleaning, disinfecting, rinsing, soaking and storage of soft (hydrophilic) contact lenses. In addition, the NDS Finishing Solution is indicated to dissolve enzyme tablets.

On April 18, 1991, the Ophthalmic Devices Panel of the Medical Devices Advisory Committee, an FDA advisory committee, reviewed and recommended approval of the application. On January 10, 1994, CDRH approved the application by a letter to the applicant from the Acting Director of the Office of Device Evaluation, CDRH.

A summary of the safety and effectiveness data on which CDRH based its approval is on file in the Docket Management Branch (address above) and is available from that office upon written request. Requests should be identified with the name of the device and the docket number found in brackets in the heading of this document.

#### Opportunity for Administrative Review

Section 515(d)(3) of the act (21 U.S.C. 360e(d)(3)) authorizes any interested person to petition, under section 515(g) of the act (21 U.S.C. 360e(g)), for administrative review of CDRH's decision to approve this application. A petitioner may request either a formal hearing under part 12 (21 CFR part 12) of FDA's administrative practices and procedures regulations or a review of the application and CDRH's action by an independent advisory committee of experts. A petition is to be in the form of a petition for reconsideration under § 10.33(b) (21 CFR 10.33(b)). A petitioner shall identify the form of review requested (hearing or independent advisory committee) and shall submit with the petition supporting data and information showing that there is a genuine and substantial issue of material fact for

resolution through administrative review. After reviewing the petition, FDA will decide whether to grant or deny the petition and will publish a notice of its decision in the *Federal Register*. If FDA grants the petition, the notice will state the issue to be reviewed, the form of review to be used, the persons who may participate in the review, the time and place where the review will occur, and other details.

Petitioners may, at any time on or before May 18, 1994, file with the Dockets Management Branch (address above) two copies of each petition and supporting data and information, identified with the name of the device and the docket number found in brackets in the heading of this document. Received petitions may be seen in the office above between 9 a.m. and 4 p.m., Monday through Friday.

This notice is issued under the Federal Food, Drug, and Cosmetic Act (secs. 515(d), 520(h) (21 U.S.C. 360e(d), 360j(h))) and under authority delegated to the Commissioner of Food and Drugs (21 CFR 5.10) and redelegated to the Center for Devices and Radiological Health (21 CFR 5.53).

Dated: March 10, 1994.

Joseph A. Levitt,

Deputy Director for Regulations Policy, Center for Devices and Radiological Health.

[FR Doc. 94-9190 Filed 4-15-94; 8:45 am]

BILLING CODE 4160-01-F

## Health Resources and Services Administration

### Advisory Council; Notice of Meeting

In accordance with section 10(a)(2) of the Federal Advisory Committee Act (Pub. L. 92-463), announcement is made of the following National Advisory body scheduled to meet during the month of May 1994:

*Name:* National Advisory Council on Nurse Education and Practice

*Date and Time:* May 12-13, 1994 8:30 a.m.-5 p.m.

*Place:* Conference Room E, Parklawn Building, 5600 Fishers Lane, Rockville, Maryland 20857.

Closed on May 13, 8:30 a.m.-10 a.m.—Open for the remainder of the meeting.

*Purpose:* The Council advises the Secretary and Administrator, Health Resources and Services Administration, concerning general regulations and policy matters arising in the administration of the Nursing Education and Practice Improvement Amendments of 1992 (Pub. L. 102-148). The Council also performs final review of selected grant applications for Federal Assistance, and makes recommendations to the Administrator, HRSA.

*Agenda:* The open portion of the meeting will cover announcements; considerations of

minutes of previous meeting; the reports of the Administrator, Health Resources and Services Administration, the Director, Bureau of Health Professions, the Director, Division of Nursing; and Council discussions of workforce projections. The meeting will be closed to the public on May 13, from 8:30 a.m. to 10 a.m. for the review of grant applications for Nursing Education Opportunities for Individuals from Disadvantaged Backgrounds. The closing is in accordance with the provisions set forth in section 552b(c)(6), title 5 U.S.C., and the Determination by the Associate Administrator for Policy Coordination, Health Resources and Services Administration, pursuant to Public Law 92-463.

Anyone requiring information regarding the subject Council should contact Ms. Denise Geolot, Deputy Director, Division of Nursing, room 9-35, Parklawn Building, 5600 Fishers Lane, Rockville, Maryland 20857, Telephone (301) 443-5786.

Agenda Items are subject to change as priorities dictate.

Dated: April 12, 1994.

Jackie E. Baum,

Advisory Committee Management Officer, HRSA.

[FR Doc. 94-9187 Filed 4-15-94; 8:45 am]

BILLING CODE 4160-15-P

### Advisory Council; Notice of Meeting

In accordance with section 10(a)(2) of the Federal Advisory Committee Act (Pub. L. 92-463), announcement is made of the following National Advisory body scheduled to meet during the month of June 1994:

*Name:* Maternal and Child Health Research Grants Review Committee

*Date and Time:* June 8-10, 1994, 9 a.m.

*Place:* Maryland Room, 3rd Floor, Parklawn Building, 5600 Fishers Lane, Rockville, Maryland 20857.

Open on June 8, 1994, 9 a.m.-10 a.m.—Closed for remainder of meeting.

*Purpose:* To review research grant applications in the program area of maternal and child health administered by the Maternal and Child Health Bureau.

*Agenda:* The open portion of the meeting will cover opening remarks by the Director, Division of Systems, Education and Science, Maternal and Child Health Bureau, who will report on program issues, congressional activities and other topics of interest to the field of maternal and child health. The meeting will be closed to the public on June 8 at 10 a.m. for the remainder of the meeting for the review of grant applications. The closing is in accordance with the provisions set forth in section 552b(c)(6), title 5 U.S.C., and the Determination by the Associate Administrator for Policy Coordination, Health Resources and Services Administration, pursuant to Public Law 92-463.

Anyone requiring information regarding the subject Council should contact Gontran Lamberty, Dr.P.H., Executive Secretary,

Maternal and Child Health Research Grants Review Committee, Room 18A-55, Parklawn Building, 5600 Fishers Lane, Rockville, Maryland 20857, Telephone (301)443-2190.

Agenda Items are subject to change as priorities dictate.

Dated: April 12, 1994.

Jackie E. Baum,

Advisory Committee Management Officer, HRSA.

[FR Doc. 94-9188 Filed 4-15-94; 8:45 am]

BILLING CODE 4160-15-P

### Statement of Organization, Functions, and Delegations of Authority; Public Health Service Order of Succession

Part H, Public Health Service (PHS), Chapter H, of the Statement of Organization, Functions, and Delegations of Authority for the Department of Health and Human Services (HHS) (42 FR 61318, December 2, 1977, as amended most recently in pertinent part at 55 FR 21116, May 22, 1990) is further amended to revise Section H-30, Public Health Service—Order of Succession. This revision identifies the successor to head the Public Health Service in the absence of the Assistant Secretary for Health.

#### Public Health Service

Under *Chapter H, Section H-30, Public Health Service—Order of Succession*, delete the statement in its entirety and substitute the following:

During the absence or disability of the Assistant Secretary for Health, or if that position becomes vacant, the principal Deputy Assistant Secretary for Health shall act as the Assistant Secretary for Health.

During the vacancy, absence or disability of the Principal Deputy Assistant Secretary for Health, the Deputy Assistant Secretary for Health (DASH) shall act as the Principal Deputy Assistant Secretary for Health (PDASH). During the vacancy, absence or disability of both the PDASH and the DASH, the Deputy Assistant Secretary for Health Management Operations shall act as the Principal Deputy Assistant Secretary for Health.

The above order of succession also applies upon the activation of the Emergency Health and Human Services Plan upon the order of the Secretary.

Dated: March 31, 1994.

Donna E. Shalala,  
Secretary.

[FR Doc. 94-9192 Filed 4-15-94; 8:45 am]

BILLING CODE 4160-17-M

**DEPARTMENT OF THE INTERIOR****Bureau of Land Management**

[CA-010-4210-04, CACA 33918]

**Realty Action: Exchange of Land in Placer, El Dorado, Calaveras, Yuba, and Nevada Counties, CA**

AGENCY: Bureau of Land Management, Department of Interior.

**SUMMARY:** The following described public land (surface and mineral estate) is being considered for exchange under Section 206 of the Federal Land Policy and Management Act of 1976 (43 U.S.C. 1716):

**Selected Public Land****Mount Diablo Meridian***Placer County*

- T. 14 N., R. 10 E.,  
Sec. 23: all public land in sec.  
T. 15 N., R. 10 E.,  
Sec. 8: W $\frac{1}{2}$ SE $\frac{1}{4}$ .

*Yuba County*

- T. 17 N., R. 7 E.,  
Sec. 2: Lot 2, SW $\frac{1}{4}$ NE $\frac{1}{4}$ , NW $\frac{1}{4}$ SE $\frac{1}{4}$ .  
T. 18 N., R. 6 E.,  
Sec. 26: NW $\frac{1}{4}$ SW $\frac{1}{4}$ .

*Calaveras County*

- T. 6 N., R. 13 E.,  
Sec. 3: Lot 7.

*El Dorado County*

- T. 8 N., R. 12 E.,  
Sec. 13: lot 1.  
T. 8 N., R. 13 E.,  
Sec. 4: all public land in SW $\frac{1}{4}$ SW $\frac{1}{4}$ ;  
Sec. 18: all public land in sec.

*Nevada County*

- T. 16 N., R. 9 E.,  
Sec. 18: lots 16 and 19.  
T. 16 N., R. 10 E.,  
Sec. 30: lot 13,  
Sec. 31: lots 14, 15, 16, 19 and 20.  
T. 17 N., R. 7 E.,  
Sec. 23: lots 2, 4 and 5;  
Sec. 24: lot 5.  
T. 17 N., R. 10 E.,  
Sec. 20: SE $\frac{1}{4}$ SE $\frac{1}{4}$ ;  
Sec. 28: Lots 5, 6 and 7.  
Totaling 800-acres, more or less.

In exchange for various Federal properties, the public would receive private land located on the North or South Fork of the American River, Cosumnes River, and/or the Merced River. Private properties being considered for acquisition include the following:

**Offered Private Land****Mount Diablo Meridian***Placer County*

- T. 15 N., R. 10 E., M.D.M.,  
Secs. 10 & 15: Mineral Survey 725;  
Sec. 15: lot 1.

Totaling 112-acres, more or less.

**SUPPLEMENTARY INFORMATION:** The Federal land would be transferred subject to a reservation to the United States for a right-of-way for ditches and canals; also any rights-of-way of record would be identified as prior existing rights. The proposal is consistent with current land use plans and is considered to be in the public interest.

All necessary clearances including clearances for archaeology, rare plants and animals would be completed prior to any conveyance of title by the United States.

The selected public land described in this notice is hereby segregated from settlement, location and entry under the public land laws and from the mining laws for a period of two years from the date of publication of this notice in the Federal Register.

**ADDRESSES:** For a period of 45 days from publication of this notice in the Federal Register, interested parties may submit comments to the District Manager, c/o the Area Manager, Folsom Resource Area, 63 Natoma Street, Folsom, CA 95630.

**FOR ADDITIONAL INFORMATION CONTACT:** Mike Kelley at the above address or by phone at (916) 985-4474.

**Timothy J. Carrol,**

*Acting Area Manager.*

[FR Doc. 94-9264 Filed 4-15-94; 8:45 am]

**BILLING CODE 4310-40-M**

[NV-930-4210-04; N-41566-21/N-57773; 4-00154]

**Termination of Recreation and Public Purposes Classification and Notice of Realty Action To Add Lands to Exchange Proposal, Clark County, Nevada**

AGENCY: Bureau of Land Management, Interior.

**ACTION:** Notice of realty action.

**SUMMARY:** This notice terminates Recreation and Public Purpose (R&PP) classification N-41566-21 in its entirety. The following described lands are affected:

**Mount Diablo Meridian, Nevada**

- T. 22 S., R. 61 E.,  
Sec. 23, SE $\frac{1}{4}$ NW $\frac{1}{4}$ NE $\frac{1}{4}$ .

The parcel was classified for disposal under the R&PP Act by publication in the **Federal Register** (55 FR 498) on January 5, 1990, and is no longer needed for school site purposes. The Bureau of Land Management is considering an exchange proposal involving this parcel. This publication shall also be considered the Notice of Realty Action

for including this parcel in exchange proposal (N-57773) filed by Olympic Land Corporation. Except for exchange purposes, the land will remain closed to all forms of appropriation under the public land laws including the general mining laws. Disposal of this parcel is consistent with the Bureau's planning for the lands involved and would be in the public interest. For a period of 45 days from the date of publication of this notice in the **Federal Register**, interested parties may submit comments concerning this classification to the District Manager, Las Vegas District, P.O. Box 26569, Las Vegas, Nevada 89126. Any adverse comments will be reviewed by the State Director.

Dated: April 12, 1994.

**Gary Ryan,**

*District Manager.*

[FR Doc. 94-9285 Filed 4-15-94; 8:45 am]

**BILLING CODE 4310-HC-M**

[UT-060-04-4320-03]

**Notice of Intent for Plan Amendment**

AGENCY: Bureau of Land Management, Interior.

**ACTION:** Notice of Intent—Proposal for Plan Amendment for the Grand Resource Area Resource Management Plan, Grand and San Juan Counties, Utah.

**SUMMARY:** This notice of intent is to advise the public that the Bureau of Land Management (BLM) proposes to amend the Grand Resource Management Plan. The existing Management Actions for wildlife habitat requirements, livestock requirements, critical watersheds, and recreation are proposed to be amended. The BLM is proposing to amend the 1985 Grand Resource Management Plan which involves portions of Grand and San Juan Counties, Utah. The issues to be analyzed include the following:

- (1) Wildlife Habitat Requirements/Livestock Requirements/Critical Watersheds/Recreation on the Bogart, Cisco, Cottonwood, Diamond, Main Canyon, Arths Pasture, North Sand Flats, and South Sand Flats Allotments—reallocate livestock animal unit months (AUMs) for use by deer, elk, and pronghorn antelope to improve watershed conditions and increase recreation opportunities.
- (2) Livestock Requirements—allow for additional flexibility in modifying grazing seasons on individual allotments.

Ten Wilderness Study Areas (WSAs) are involved in the proposal. These WSAs are managed under the BLM's

Interim Management Policy (IMP) for Lands Under Wilderness Review (1979, revised 1983). The WSAs involved are Desolation Canyon (UT-060-068A), Westwater (UT-060-118), Black Ridge Canyon West (UT-060-116/117), Behind the Rocks (UT-060-140A), Negro Bill Canyon (UT-060-138), Mill Creek Canyon (UT-060-139A), Flume Canyon (UT-060-1000B), Spruce Canyon (UT-060-100C1), Coal Canyon (UT-060-100C2), and Floy Canyon (UT-060-068B).

**DATES:** Members of the public are encouraged to submit comments on this proposed amendment and the issues to be addressed. BLM will accept comments on the proposal and issues listed herein to the address listed below until May 18, 1994. An additional public protest period will be provided upon completion of the proposed amendment for Environmental Assessment/Finding of No Significant Impact.

**ADDRESSES:** Comments should be sent to Brad Palmer, Grand Resource Area Manager, Grand Resource Area, Bureau of Land Management, 885 South Sand Flats Road, Moab, Utah 84532, telephone: (801) 259-8193.

**FOR FURTHER INFORMATION CONTACT:** Brad Palmer, Grand Resource Area Manager, Grand Resource Area, (801) 259-8193.

**SUPPLEMENTARY INFORMATION:** Existing planning documents and information are available at the Grand Resource Area, 885 South Sand Flats Road, Moab, Utah 84532, telephone: (801) 259-8193.

**James M. Parker,**  
State Director.

[FR Doc. 94-9217 Filed 4-15-94; 8:45 am]

**BILLING CODE 4310-DQ-M**

## INTERSTATE COMMERCE COMMISSION

### Agency Information Collection Under OMB Review

The following proposal for collection of information under the provisions of the Paperwork Reduction Act (44 U.S.C. Chapter 35) is being submitted to the Office of Management and Budget for review and approval. Copies of the form and supporting documents may be obtained from the Agency Clearance Officer, Nancy Sipes, (202) 927-5040. Comments regarding this information collection should be addressed to Nancy Sipes, Interstate Commerce Commission, room 4136, Washington, DC 20423 and to the Office of Management and Budget, Office of Information and Regulatory Affairs,

Attn: Desk Officer for ICC, Washington, DC 20503. When submitting comments, refer to the OMB number or the title of the form.

**Type of Clearance:** Extension without change of a currently approved form.

**Bureau/Office:** Office of Compliance & Consumer Assistance.

**Title of Form:** Request for Revocation of Authority Granted.

**OMB Form Number:** 3120-0104.

**Agency Form Number:** OCCA-46.

**Frequency:** Used by regulated transportation entities to apply voluntarily for revocation of their operating rights or parts thereof.

**No. of Respondents:** 2,000.

**Total Burden Hours:** 1,000.

**Sidney L. Strickland, Jr.,**  
Secretary.

[FR Doc. 94-9280 Filed 4-15-94; 8:45 am]

**BILLING CODE 7035-01-P**

### [Section 5a Application No. 118] (Amendment No. 1)

#### EC-MAC Motor Carriers Service Association, Inc.

**AGENCY:** Interstate Commerce Commission.

**ACTION:** Notice of proposed amendment to agreement.

**SUMMARY:** EC-MAC Motor Carriers Service Association, Inc. (EC-MAC), has petitioned for approval to amend section 4 of the bylaws to its ratemaking agreement approved under 49 U.S.C. 10706(b). The proposed amendment expands the agreement's territorial scope to embrace "the transportation of property in interstate and/or foreign commerce between and from and to all points in the United States." It eliminates the territorial and commodity restrictions that currently characterize the agreement. No changes are proposed in the agreement's ratemaking procedures.

**DATES:** Comments are due by May 18, 1994.

**ADDRESSES:** Send comments referring to section 5(a) Application No. 118 (Amendment No. 1), EC-MAC Motor Carriers Service Association, Inc., to Office of the Secretary, Case Control Branch, Interstate Commerce Commission, Washington, DC 20423.

**FOR FURTHER INFORMATION CONTACT:** Beryl Gordon (202) 927-5610. [TDD for hearing impaired: (202) 927-5721.]

*Decided:* April 11, 1994.

By the Commission, David M. Konschnik, Director, Office of Proceedings.

**Sidney L. Strickland, Jr.,**  
Secretary.

[FR Doc. 94-9281 Filed 4-15-94; 8:45 am]

**BILLING CODE 7035-01-P**

## DEPARTMENT OF LABOR

### Office of the Secretary

#### Commission on the Future of Worker-Management Relations; Notice of Closing the Public Record

**AGENCY:** Office of the Secretary, Labor.

**ACTION:** Notice of closing the public record.

**SUMMARY:** The Commission on the Future of Worker-Management Relations was established in accordance with the Federal Advisory Committee Act (FACA) Public Law 92-463. Pursuant to section 10(a) of FACA, this is to announce that as of April 29, 1994, the Commission will close the public record with respect to the preparation and submission of its report of findings to the Secretary of Labor and the Secretary of Commerce.

Those who wish to make comments on matters already on the record should do so by April 29, 1994. The Commission will reopen the record during the second phase of its work when attention will be turned to developing the final report, including recommendations.

Individuals or organizations wishing to submit written statements should send them to Mrs. June M. Robinson, Designated Federal Official, Commission on the Future of Worker-Management Relations, room C-2318, U.S. Department of Labor, 200 Constitution Avenue, NW., Washington, DC 20210, telephone (202) 219-9148, fax (202) 219-9167.

Signed at Washington, DC this 11th day of April, 1994.

**June M. Robinson,**  
Designated Federal Official.

[FR Doc. 94-9249 Filed 4-15-94; 8:45 am]

**BILLING CODE 4510-23-M**

### Employment and Training Administration

[SGA No. DAA 94-008]

#### Job Training Partnership Act: Learning Consortia Project

**AGENCY:** Employment and Training Administration, Labor.



**ACTION:** Notice of Availability of Funds and Solicitation for Grant Applications (SGA).

**SUMMARY:** The U.S. Department of Labor, Employment and Training Administration, under Title IV of the Job Training Partnership Act is soliciting proposals on a competitive basis to assist consortia of for-profit organizations in addressing their workforce and workplace improvement needs to develop highly skilled workers and increase company competitiveness. The Department has set aside approximately \$500,000 for this procurement. As a result of this solicitation, multiple awards will be made. All information required to submit a proposal is contained in this announcement.

**DATES:** Applications for grant awards will be accepted commencing April 18, 1994. The closing date for receipt of applications shall be May 20, 1994, at 2:00 p.m. (Eastern Time).

**ADDRESSES:** Applications shall be mailed to the Division of Acquisition and Assistance, Attention: Willie E. Harris, Reference: SGA/DAA 94-008, Employment and Training Administration, U.S. Department of Labor, Room S-4203, 200 Constitution Avenue, NW., Washington, DC 20210.

**FOR FURTHER INFORMATION CONTACT:** Willie E. Harris, Division of Acquisition and Assistance. Telephone (202) 219-8702 (this is not a toll free number).

**SUPPLEMENTARY INFORMATION:** This announcement consists of five parts: Part I—Background, Part II—Application Process, Part III—Statement of Work, Part IV—Evaluation Criteria, and Part V—Reporting Requirements.

#### Part I—Background

The Department of Labor's (DOL's) mission is to ensure that all Americans have access to the resources they require to successfully manage their job lives, and that U.S. businesses have access to the skilled workers and training and technical assistance resources they need to successfully compete in a global economy. DOL's strategy for accomplishing this mission involves the building of new relationships with state and local partners and investing federal dollars to strengthen the effectiveness of local labor markets.

This solicitation represents an attempt to build such a new relationship through learning consortia, networks of otherwise unrelated for-profit organizations, particularly small businesses, forged to develop interfirm learning and information-sharing systems focused on workforce

development and the changing workplace. Through each consortium, DOL hopes (1) to share human resource development tools or information about new work systems implementation, and (2) establish a cooperative learning system like a learning center or teaching factory.

Forming a learning consortium makes sense from the individual small companies' standpoint because a network of small organizations are better positioned to facilitate cost-effective, high quality workforce and workplace development programs than a small business acting alone. A consortium enables small businesses to more accurately identify common training needs, to locate and coordinate the services of assistance providers that can effectively address those needs, and to share training programs and other resources among member organizations.

From a public policy perspective, learning consortia afford regional, state and local workforce and economic development policy makers and assistance providers points of access to reach a wider spectrum of firms through their business outreach efforts. Dealing with consortia of small organizations rather than individual organizations allows assistance providers to leverage the investment of scarce resources. Learning consortia have tremendous potential to help alleviate this nation's growing dislocated worker problem in several ways:

(1) Consortia of businesses can be effective training and technical assistance delivery systems to upgrade incumbent workers' skills and improve company productivity to prevent worker dislocations.

(2) Consortia learning systems, like learning centers and teaching factories, have the potential of being effective providers for dislocated worker retraining.

(3) Networks of globally competitive small businesses could create new jobs for the reemployment of dislocated workers.

Currently, there are hundreds of examples of successful interfirm networks operating across the country. For some, a geographic cluster is the basis for forging the network. Others are formed as part of a supplier development strategy, an industry association strategy, or as a regional economic development strategy.

#### Part II—Application Process

##### A. Eligible Applicants

This solicitation is open to consortia of for-profit organizations. A consortium whose members include non-profit

organizations and other entities may submit an application if the majority of the consortium members are for-profit organizations. A consortium applicant must include either "small businesses" with 500 or fewer employees or small entities, such as subsidiaries or divisions of large businesses, with 500 or fewer employees. In addition, an application shall identify a "host organization" to represent the consortium applicant. The host organization need not be a member of the consortium.

Examples of host organizations include: companies, trade associations, unions, economic development organizations, local government or state agencies, technology assistance organizations, and educational institutions. In addition, the host organization will provide for a "Network broker," an individual who serves to convene the consortium on a regular basis, administers and coordinates supportive services, and assists in defining goals of the consortium. Any award made as a result of this solicitation will be non-fee bearing.

##### B. Submission of Proposal

An original and three (3) copies of the proposal shall be submitted. The proposal shall consist of two (2) separate and distinct parts.

Part I—shall contain the cost proposal, consisting of the following items: Standard Form (SF) 424, "Application for Federal Assistance" (Appendix No. 1) and SF 424A, "Budget" (Appendix No. 2). The cost proposal shall also include on a separate page(s) a detailed cost analysis of each line item in the budget.

Part II—shall contain a technical proposal that demonstrates the applicant's capabilities in accordance with the Statement of Work contained in this announcement. Applicants are strongly encouraged to submit a technical proposal of less than thirty (30) pages in length (exclusive of appendices) which sets forth the applicant's explanation of how it proposes to accomplish the elements described in the Statement of Work.

No cost data or reference to price shall be included in the technical proposal. In order to assist applicants in preparing their proposals and to facilitate the expeditious evaluation by the review panel, proposals should be organized and presented in the same sequential order as the Evaluation Criteria in Part IV of this announcement.

### C. Hand-Delivered Proposals

Proposals should be mailed at least five (5) days prior to the closing date. However, if proposals are hand-delivered, they shall be received at the designated place by 2 p.m., Eastern Time by May 20, 1994. All overnight mail will be considered to be hand-delivered and must be received at the designated place by the specified closing date. Telegraphed and/or faxed proposals will not be honored. Failure to adhere to the above instructions will be a basis for a determination of nonresponsiveness.

### D. Late Proposals

Any proposal received at the office designated in the solicitation after the exact time specified for receipt will not be considered unless it is received before award is made and it—

(1) Was sent by U.S. Postal Service registered or certified mail not later than the fifth calendar day before the date specified for receipt of application (e.g., an offer submitted in response to a solicitation requiring receipt of applications by the 20th of the month must have been mailed by the 15th); or

(2) Was sent by U.S. Postal Service Express Mail Next Day Service—Post Office of Addresses, not later than 5 p.m. at the place of mailing two working days prior to the date specified for receipt of proposals. The term "working days" excludes weekends and U.S. Federal holidays.

The only acceptable evidence to establish the date of mailing of a late proposal sent either by U.S. Postal Service registered or certified mail is the U.S. postmark both on the envelope or wrapper and on the original receipt from the U.S. Postal Service. Both postmarks must show a legible date or the proposal, shall be processed as if mailed late. "Postmark" means a printed, stamped, or otherwise placed impression (exclusive of a postage meter machine impression that is readily identifiable without further action as having been supplied and affixed by employees of the U.S. Postal Service on the date of mailing. Therefore, applicants should request the postal clerk to place a legible hand cancellation "bull's eye" postmark on both the receipt and the envelope or wrapper.

The only acceptable evidence to establish the date of mailing of a late proposal sent by "Express Mail Next Day Service—Post Office to Addressee" is the date entered by the post office receiving clerk on the "Express Mail Next Day Service—Post Office to Addressee" label and the postmark on

both the envelope or wrapper and on the original receipt from the U.S. Postal Service. "Postmark" has the same meaning as defined above. Therefore, applicants should request the postal clerk to place a legible hand cancellation "bull's eye" postmark on both the receipt and the envelope or wrapper.

### E. Withdrawal of Proposals

Proposals may be withdrawn by written notice or telegram (including mailgram) received at any time before award. Proposals may be withdrawn in person by an applicant or an authorized representative thereof, if the representative's identity is made known and the representative signs a receipt for the proposal before award.

### F. Period of Performance

The period of performance will be 12 months from the date of grant execution.

### G. Funding

DOL has set aside up to \$500,000 to be disbursed. It is anticipated that multiple grant awards will be made with the maximum award amount to be \$100,000.

### H. Option To Extend

Based on the availability of funds, effective program operation, and the needs of the Department, the grant(s) may be extended for up to one (1) additional year.

### Part III—Statement of Work

The Department of Labor is soliciting proposals for the development or enhancement of interfirm networks of companies focused on human resource development and related workplace practices in member small businesses.

The proposals should discuss the following items:

1. The applicant's vision of how the project will contribute to the Department of Labor's mission to ensure that all Americans have access to the resources they require to successfully manage their job lives, and that U.S. businesses have access to the skilled workers and technical assistance (training, labor-management relations, work restructuring, basic skills, workplace practices) resources they need to successfully compete in a global economy.

2. An analysis of economic, technological and workplace trends, within a consortium's geographic region or industrial sector, that require specific skills or workers in consortium small businesses and demonstrate the need for the learning consortium.

3. Clear articulation of workforce and workplace development goals of the

consortium and its member organizations, as tied to identified economic, technological and workplace trends; and a justification of the consortium approach as the best vehicle for accomplishing these goals.

4. The identification of "best practice" examples of successful learning consortia both in the U.S. and abroad and suggested incorporation of "lessons learned" from those examples in the proposed project.

5. A plan for the development of a learning system for the member firms linked to the internal training and workplace practices needs of the firms as well as to the collective goals and objectives of the network.

6. Identification of training and technical assistance providers involved in the consortium learning system, that can address member firms' workforce and workplace development needs.

7. A plan for the evaluation of outcomes related to the consortium's workforce and workplace development and training goals.

8. The role of the learning consortium in the development and implementation of broader regional economic development strategies.

9. The role of the consortium in the retraining and reemployment of dislocated workers.

10. The proposal should explain its commitment to maintaining the workforce and workplace development focus of the consortium through a contribution of resources to these activities during the grant period, as well as in the future.

The role of the network broker and the host organization is key to successful planning and implementation of the project. The network broker and host organization must be able to assist the consortium in identifying its workforce and workplace development goals, help choose the targeted companies, facilitate the needs assessment, coordinate program development with the service providers, prepare the development plan, serve as a liaison between the consortium and service providers, monitor the training and the workplace change process, and prepare the evaluation and dissemination of results.

### Part IV—Evaluation Criteria

Prospective offerors are advised that the selection of the grantee for the award is to be made after careful evaluation of proposals by a panel within DOL. Each panelist will evaluate the proposals based on the factors enumerated below.

**A. Basic Soundness of Proposal (40 Points):**

The degree to which the proposal demonstrates an understanding of, and incorporates, each of the following items:

1. An explanation of the potential contribution of the learning consortium to the Department of Labor's mission to ensure that all Americans have access to the resources they require to successfully manage their job lives, and that U.S. businesses have access to the skilled workers and training and technical assistance resources they need to successfully compete in a global economy;

2. An analysis of economic, technological and workplace trends, within a consortium's geographic region or industrial sector, that require specific skills of workers in consortium small businesses and demonstrate the need for the learning consortium;

3. The identification of "best practice" examples of successful learning consortia both in the United States and abroad; and incorporation into the proposal of "lessons learned" from an examination of networks that have successfully implemented interfirm learning systems;

4. An explanation of the importance of a consortium strategy for improving workforce development and firm performance including: a specification of the workforce and workplace development goals of the consortium and its small business members as tied to identified regional, technological, or workplace trends; and a proposed implementation plan (learning system) for providing training and assistance for member firms linked to internal training and workplace practices needs of the firms, as well as to the goals of the network;

5. The identification of training and technical assistance providers involved in the consortium's learning system, that can address member firms' workforce and workplace development needs.

6. An explanation of a plan for the evaluation of outcomes related to the consortium's workforce and workplace development and training goals.

7. An explanation of the role of the learning consortium in the development and implementation of broader regional economic development strategies; and

8. An explanation of the plan for adapting the consortium to retrain and reemploy dislocated workers.

Members of each consortium submitting a proposal for funds should demonstrate their commitment to maintaining the workforce and workplace development focus of the consortium through a contribution of resources to these activities.

**B. The Degree of Involvement and Commitment by the Individual Firms and Supporting Organizations (30 Points)**

The proposal should demonstrate that the learning consortium has the level of commitment required to ensure continuation after the one-year grant period. Participation and involvement must be demonstrated in the following manner:

1. The commitment of non-federal financial and/or other resources to the consortium; and

2. The linkage of the consortium with broader economic development or firm assistance programs and the involvement of training providers.

**C. Organizational Capabilities (30 Points)**

The proposal must demonstrate that the proposing organization possesses the capability to successfully manage the learning consortium; and has experience in interfirm cooperative efforts and human resource development. The level of experience and qualifications possessed by the network broker and key project staff will be evaluated and must be supplied with the proposal.

Applicants are advised that discussions may be necessary in order

to clarify any inconsistencies in their applications. The panel results are advisory in nature and not binding on the Grant Officer. The ETA Grant Officer will make the final decision on all grant awards based on what is most advantageous to the Federal Government.

**Part V—Reporting Requirements****A. Quarterly Financial Reports**

The grantee shall submit to the Grant officer, within 30 days following the end of each quarter, three copies of a quarterly Financial Status Report (SF 269) until such time as all funds have been expended or the period of availability has expired.

**B. Quarterly Progress Reports**

The grantee shall submit to the Grant officer within 30 days following the end of each quarter, three copies of a quarterly progress report. Reports shall include the following in brief narrative form:

(1) A description of overall progress of work activities accomplished during the reporting period.

(2) An indication of current problems, if any, which may delay performance and proposed corrective action.

(3) Program status and financial data/information relative to expenditure rate versus budget, anticipated staff changes, etc.

**C. Final Report**

A draft final report which summarizes project activities and results of the project shall be submitted 60 days before the expiration date of the grant award. The final report shall be submitted in 3 copies by the expiration of the grant.

Signed at Washington, DC, this 12th day of April.

Janice E. Perry,  
Grant Officer, Division of Acquisition and Assistance.

BILLING CODE 4510-30-M

### APPLICATION FOR FEDERAL ASSISTANCE

<b>1. TYPE OF SUBMISSION:</b> <i>Application</i> <input type="checkbox"/> Construction <input type="checkbox"/> Non-Construction  <i>Preapplication</i> <input type="checkbox"/> Construction <input type="checkbox"/> Non-Construction		2. DATE SUBMITTED	Applicant Identifier
		3. DATE RECEIVED BY STATE	State Application Identifier
		4. DATE RECEIVED BY FEDERAL AGENCY	Federal Identifier
<b>5. APPLICANT INFORMATION</b>			
Legal Name:		Organizational Unit:	
Address (give city, county, state, and zip code):		Name and telephone number of the person to be contacted on matters involving this application (give area code)	
<b>6. EMPLOYER IDENTIFICATION NUMBER (EIN):</b> [ ] [ ] [ ] - [ ] [ ] [ ] [ ] [ ] [ ] [ ] [ ] [ ] [ ]		<b>7. TYPE OF APPLICANT: (enter appropriate letter in box)</b> <input type="checkbox"/>	
<b>8. TYPE OF APPLICATION:</b> <input type="checkbox"/> New <input type="checkbox"/> Continuation <input type="checkbox"/> Revision If Revision, enter appropriate letter(s) in box(es): <input type="checkbox"/> <input type="checkbox"/> A. Increase Award    B. Decrease Award    C. Increase Duration D. Decrease Duration    Other (specify): _____		A. State B. County C. Municipal D. Township E. Interstate F. Intermunicipal G. Special District H. Independent School Dist. I. State Controlled Institution of Higher Learning J. Private University K. Indian Tribe L. Individual M. Profit Organization N. Other (Specify): _____	
<b>9. NAME OF FEDERAL AGENCY:</b> _____			
<b>10. CATALOG OF FEDERAL DOMESTIC ASSISTANCE NUMBER:</b> [ ] [ ] [ ] [ ] - [ ] [ ] [ ] [ ] [ ] [ ] [ ] [ ] [ ] [ ] TITLE: _____		<b>11. DESCRIPTIVE TITLE OF APPLICANT'S PROJECT:</b> _____	
<b>12. AREAS AFFECTED BY PROJECT (cities, counties, states, etc.):</b> _____			
<b>13. PROPOSED PROJECT:</b> Start Date    Ending Date		<b>14. CONGRESSIONAL DISTRICTS OF:</b> a. Applicant b. Project	
<b>15. ESTIMATED FUNDING:</b>		<b>16. IS APPLICATION SUBJECT TO REVIEW BY STATE EXECUTIVE ORDER 12372 PROCESS?</b>	
a. Federal	\$	.00	a. YES. THIS PREAPPLICATION/APPLICATION WAS MADE AVAILABLE TO THE STATE EXECUTIVE ORDER 12372 PROCESS FOR REVIEW ON: DATE _____ b. NO. <input type="checkbox"/> PROGRAM IS NOT COVERED BY E.O. 12372 <input type="checkbox"/> OR PROGRAM HAS NOT BEEN SELECTED BY STATE FOR REVIEW
b. Applicant	\$	.00	
c. State	\$	.00	
d. Local	\$	.00	
e. Other	\$	.00	
f. Program Income	\$	.00	
g. TOTAL		\$	.00
<b>17. IS THE APPLICANT DELINQUENT ON ANY FEDERAL DEBT?</b> <input type="checkbox"/> Yes    If "Yes," attach an explanation. <input type="checkbox"/> No			
<b>18. TO THE BEST OF MY KNOWLEDGE AND BELIEF, ALL DATA IN THIS APPLICATION/PREAPPLICATION ARE TRUE AND CORRECT, THE DOCUMENT HAS BEEN DULY AUTHORIZED BY THE GOVERNING BODY OF THE APPLICANT AND THE APPLICANT WILL COMPLY WITH THE ATTACHED ASSURANCES IF THE ASSISTANCE IS AWARDED</b>			
a. Typed Name of Authorized Representative		b. Title	c. Telephone number
d. Signature of Authorized Representative		e. Date Signed	

Previous Editions Not Usable

Standard Form 424 (REV 4-88)  
 Prescribed by OMB Circular A-102

Authorized for Local Reproduction

**BUDGET INFORMATION - Non Construction Programs**

Catalog of Federal Domestic Assistance		Estimated Unobligated Funds				New or Revised Budget			
CFDA NUMBER		FEDERAL	NON-FEDERAL	FEDERAL	NON-FEDERAL	FEDERAL	NON-FEDERAL	FEDERAL	NON-FEDERAL
1.		\$ _____	\$ _____	\$ _____	\$ _____	\$ _____	\$ _____	\$ _____	\$ _____
2.		\$ _____	\$ _____	\$ _____	\$ _____	\$ _____	\$ _____	\$ _____	\$ _____
COST CATEGORY	FEDERAL FUNDING				NON-FEDERAL CONTRIBUTION				
	CURRENT FEDERAL BUDGET	REVISIONS AND/OR EXTENSIONS	REVISED FEDERAL BUDGET	CURRENT AWARD BUDGET	REVISIONS AND/OR EXTENSIONS	REVISED AWARD BUDGET	CURRENT AWARD BUDGET	REVISIONS AND/OR EXTENSIONS	REVISED AWARD BUDGET
(A) PERSONNEL									
(B) FRINGE BENEFITS									
(C) TRAVEL & PER DIEM									
(D) EQUIPMENT									
(E) SUPPLIES									
(F) CONTRACTUAL									
(G) OTHER									
TOTAL DIRECT COST									
INDIRECT COST									
TOTAL ESTIMATED COST									

## Occupational Safety and Health Administration

### Utah State Standards; Approval

*Background:* Part 1953 of title 29, Code of Federal Regulations prescribes procedures under section 18 of the Occupational Safety and Health Act of 1970 (29 U.S.C. 667), (hereinafter called, the Act) by which the Regional Administrator for Occupational Safety and Health (hereinafter called the Regional Administrator) under delegation of authority from the Assistant Secretary of Labor for Occupational Safety and Health (hereinafter called the Assistant Secretary), (29 CFR 1953.4) will review and approve standards promulgated pursuant to a State Plan which has been approved in accordance with section 18(c) of the Act and 29 CFR part 1202.

On January 10, 1973, notice was published in the *Federal Register* (38 FR 1178) of the approval of the Utah State Plan and the adoption of subpart E to part 1952 containing the decision. Utah was granted final approval on section 18(e) of the Act on July 16, 1985. By law (section 63-46a-16 Utah Code,) the Utah Administrative Rulemaking Procedure is the authorized compilation of the administrative law of Utah and "shall be received in all the courts, and by all the judges, public officers, commissioners, and departments of the State government as evidence of the administrative law of the State of Utah \* \* \*." The Utah Occupational Safety and Health Division revised its Administrative Rulemaking Act (chapter 46a, title 63, Utah annotated, 1953) which became effective on April 29, 1985. On May 6, 1985, a State Plan Supplement was submitted to the Occupational Safety and Health Administration (OSHA) for approval and publication in the *Federal Register*. The plan supplement was published in the *Federal Register* (53 FR 43688) on October 28, 1988. The supplement provides for adoption of Federal standards by reference through the publication of standards in the Utah State Digest. Utah now adopts Federal OSHA standards by reference using the OSHA numbering system.

Following the publication date, the agency shall allow at least 30 days for public comment on the rule. During the public comment period the agency may hold a hearing on the rule. Except as provided in statutes 63-46a-6 and 63-46a-7, a proposed rule becomes effective on any date specified by the agency which is no fewer than 30 nor more than 90 days after the publication date. The agency shall provide written

notification of the rule's effective date to the office. Notice of the effective date shall be published in the next issue of the bulletin.

OSHA regulations (29 CFR 1953.22 and 1953.23) require that States respond to the adoption of new or revised permanent Federal Standards by State promulgation of comparable standards within six months of OSHA publication in the *Federal Register*, and within 30 days for emergency temporary standards. Although adopted State Standards or revisions to standards must be submitted for OSHA review and approval under procedures set forth in part 1953, they are enforceable by the State prior to Federal review and approval. The State submitted statements along with copies of the Utah State Digest, to verify the adoption by reference of a standard for the Code of Federal Regulations. The adoption by reference standards actions occurred as follows: The Industrial Commission of Utah, Occupational Safety and Health Division, adopted by reference on December 1, 1993, the Federal Standard, Lead Exposure in Construction; Interim Final Rule of 29 CFR part 1910 as published in 58 FR 26590. The effective date of the State Rule was January 3, 1994.

*Decision:* The statement of incorporation of the aforementioned Federal Standard by reference has been printed in the Utah Administrative Code. The code contains the statement of the incorporation of Federal Standards by reference as compiled by the Occupational Safety and Health Division of the Industrial Commission of Utah. Copies of the Utah Administrative Code have been reviewed and verified at the Regional Office. OSHA has determined that the Federal Standards incorporated by reference from 29 CFR part 1910 are identical to Federal Standards with no differences and therefore approves the Utah Standards.

*Location of Supplement For Inspection and Copying.* A copy of the standards along with the approved plan may be inspected and copied during normal business hours at the following location: Office of the Regional Administrator, room 1576 Federal Office Building, 1961 Stout Street, Denver, Colorado 80294; Utah State Industrial Commission, UOSH Offices at 160 East 300 South, Salt Lake City, Utah 84151; and the Director, Federal-State Operations, room N3700, 200 Constitution Ave, NW., Washington, DC 20210.

*Public Participation.* Under 29 CFR 1953.2 (c), the Assistant Secretary may prescribe alternative procedures, or

show any other good cause consistent with applicable laws, to expedite the review process. The Assistant Secretary finds that good cause exists for not publishing the supplements to the Utah State Plan as a proposed change and makes the Regional Administrator's approval effective upon publication for the following reason(s): The Standards were adopted in accordance with the procedural requirements of State law which include public comment, and further public participation would be repetitious. This decision is effective February 23, 1994.

(Sec. 18, Pub. L. 91-596, 84 Stat. 1608 [29 U.S.C. 667]).

Signed at Denver, Colorado this 23rd day of February 1994.

**Gregory J. Baxter,**

*Deputy Regional Administrator, VIII.*

[FR Doc. 94-9251 Filed 4-15-94; 8:45 am]

BILLING CODE 4510-26-M

---

## NATIONAL ARCHIVES AND RECORDS ADMINISTRATION

### Reestablishment of Advisory Committee on Presidential Libraries

This notice is published in accordance with the provisions of section 9(a)(2) of the Federal Advisory Committee Act (FACA) (Pub. L. 92-463, 5 U.S.C., App.) and advises of the reestablishment of the National Archives and Records Administration's (NARA) Advisory Committee on Presidential Libraries. In accordance with Executive Order 12838, the Office of Management and Budget has approved the continuation of this agency-established committee. The Committee Management Secretariat, General Services Administration, has also concurred with the reestablishment of the Advisory Committee in correspondence dated March 4, 1994.

The Acting Archivist of the United States has determined that the reestablishment of this Advisory Committee is in the public interest due to the expert knowledge and valuable advice the committee members provide on matters related to the effective functioning of the presidential library system. NARA uses the committee's recommendations as NARA oversees the libraries that house the personal and presidential papers of our presidents. The charter for the Advisory Committee on Presidential Libraries will be filed in accordance with 41 CFR 101-6.1013.

Dated: March 31, 1994.

**Trudy Huskamp Peterson,**

*Acting Archivist of the United States.*

[FR Doc. 94-9265 Filed 4-15-94; 8:45 am]

BILLING CODE 7515-01-M

## NATIONAL FOUNDATION ON THE ARTS AND THE HUMANITIES

### National Endowment for the Arts Meeting

Pursuant to section 10(a)(2) of the Federal Advisory Committee Act (Public Law 92-463), as amended, notice is hereby given that meeting of the Federal Advisory Committee on International Exhibitions will be held on April 28, 1994 from 9:30 a.m. to 2:30 p.m. This meeting will be held at the Seattle Art Museum in the Simons Board Room—First Floor, 100 University Street in Seattle, Washington.

A portion of this meeting will be open to the public from 1:30 p.m. to 2:30 p.m. for a policy discussion.

The remaining portion of this meeting from 9:30 a.m. to 1:30 p.m. are for the purpose of Panel review, discussion, evaluation, and recommendation on applications for financial assistance under the National Foundation on the Arts and the Humanities Act of 1965, as amended, including information given in confidence to the agency by grant applicants. In accordance with the determination of the Chairman of February 8, 1994 this session will be closed to the public pursuant to subsection (c)(4), (6) and (9)(B) of section 552b of Title 5, United States Code.

Any person may observe meetings, or portions thereof, of advisory panels which are open to the public, and may be permitted to participate in the panel's discussions at the discretion of the panel chairman and with the approval of the full-time Federal employee in attendance.

If you need special accommodations due to a disability, please contact the Office of Special Constituencies, National Endowment for the Arts, 1100 Pennsylvania Avenue, NW., Washington, DC 20506, 202/682-5532, TTY 202/682-5496, at least seven (7) days prior to the meeting.

Further information with reference to this meeting can be obtained from Ms. Yvonne Sabine, Committee Management Officer, National Endowment for the Arts, Washington, DC 20506, or call 202/682-5439.

Dated: April 13, 1994.

**Yvonne M. Sabine,**

*Director Office of Panel Operations, National Endowment for the Arts.*

[FR Doc. 94-9312 Filed 4-15-94; 8:45 am]

BILLING CODE 7537-01-M

## NATIONAL SCIENCE FOUNDATION

### Special Emphasis Panel in Biological & Critical Systems; Notice of Meeting

In accordance with the Federal Advisory Committee Act (Pub. L. 92-463, as amended), the National Science Foundation announces the following meeting.

*Name:* Special Emphasis Panel in Biological & Critical Systems.

*Date and Time:* May 3, 1994; 8:30 a.m.—5 p.m.

*Place:* National Science Foundation, 4201 Wilson Boulevard, Room 580, Arlington, VA 22230.

*Type of Meeting:* Closed.

*Contact Person:* John Enderle, Program Director, Biomedical Engineering and Research to Aid Persons with Disabilities, Division of Bioengineering and Environmental Systems, National Science Foundation, 4201 Wilson Boulevard, Arlington, VA 22230, Telephone: (703) 306-1319.

*Purpose of Meeting:* To provide advice and recommendations concerning proposals submitted to NSF for financial support.

*Agenda:* To review and evaluate proposals as part of the selection process for awards.

*Reason for Closing:* The proposals being reviewed include information of a proprietary or confidential nature, including technical information; financial data, such as salaries; and personal information concerning individuals associated with the proposals. These matters are exempt under 5 U.S.C. 552b(c), (4) and (6) of the Government in the Sunshine Act.

Dated: April 12, 1994.

**M. Rebecca Winkler,**

*Committee Management Officer.*

[FR Doc. 94-9211 Filed 4-15-94; 8:45 am]

BILLING CODE 7555-01-M

### Special Emphasis Panel in Engineering Education and Centers; Notice of Meeting

In accordance with the Federal Advisory Committee Act (Pub. L. 92-463, as amended), the National Science Foundation announces the following meeting:

*Name:* Special Emphasis Panel Engineering Education and Centers.

*Date/Time:* May 2-3, 1994, 8:30 a.m.—5 p.m.

*Place:* National Science Foundation, 4201 Wilson Blvd., Arlington, VA 22230, Room 680.

*Type of Meeting:* Closed.

*Contact Person:* Dr. Win Aung, Senior Staff Associate, Engineering Education and Centers Division, National Science Foundation, 4201 Wilson Blvd., Arlington, VA 22230, Rm. 585.

*Purpose of Meeting:* To provide advice and recommendations concerning concept papers submitted to NSF for financial support.

*Agenda:* To review and evaluate concept papers submitted to the Combined Research-Curriculum Development program.

*Reason for Closing:* The concept papers being reviewed include information of a proprietary or confidential nature, including technical information; financial data, such as salaries; and personal information concerning individuals associated with the proposals. These matters are exempt under 5 U.S.C. 552b. (c) (4) and (6) of the Government in the Sunshine Act.

Dated: April 12, 1994.

**M. Rebecca Winkler,**

*Committee Management Officer.*

[FR Doc. 94-9213 Filed 4-15-94; 8:45 am]

BILLING CODE 7555-01-M

### Special Emphasis Panel for Social, Behavioral, and Economic Research; Notice of Meeting

In accordance with the Federal Advisory Committee Act (Pub. L. 92-463, as amended), the National Science Foundation announces the following meeting:

*Name:* Special Emphasis Panel for Social, Behavioral, and Economic Research.

*Date and Time:* May 3, 1994, 8:30 a.m. to 6 p.m.

*Place:* Room 320, 4201 Wilson Boulevard, Arlington VA.

*Type of Meeting:* Closed.

*Contact Person:* Dr. Robin Cantor, Program Director for DRMS, Division of Social, Behavioral, and Economics Research, Room 995, National Science Foundation, 4201 Wilson Boulevard, Arlington, VA. Telephone: (703) 306-1757.

*Purpose of Meeting:* To provide advice and recommendations concerning proposals submitted to NSF for financial support.

*Agenda:* To review and evaluate human dimensions of global change proposals as part of the selection process for awards.

*Reason for Closing:* The proposals being reviewed include information of a proprietary or confidential nature, including technical information; financial data, such as salaries; and personal information concerning individuals associated with the proposals. These matters are exempt under 5 U.S.C. 552b(c), (4) and (6) of the Government in the Sunshine Act.

Dated: April 12, 1994.

**M. Rebecca Winkler,**

*Committee Management Officer.*

[FR Doc. 94-9212 Filed 4-15-94; 8:45 am]

BILLING CODE 7555-01-M

## NUCLEAR REGULATORY COMMISSION

### Documents Containing Reporting or Recordkeeping Requirements: Office of Management and Budget (OMB) Review

**AGENCY:** U.S. Nuclear Regulatory Commission (NRC).

**ACTION:** Notice of the OMB review of information collection.

**SUMMARY:** The NRC has recently submitted to the OMB for review the following proposal for the collection of information under the provisions of the Paperwork Reduction Act of 1980 (44 U.S.C. Chapter 35).

1. Type of submission, new, revision, or extension: New
2. The title of the information collection: NRC Survey: Licensee Plans for Augmented Examinations of Reactor Vessel Shell Welds.
3. The form number if applicable: Not applicable.
4. How often the collection is required: One time only.
5. Who will be asked to report: Licensees of operating commercial nuclear power plants.
6. An estimate of the number of responses annually: 110.
7. An estimate of the total number of hours needed annually to complete the requirement or request: 55 hours (30 minutes per licensee).
8. An indication of whether Section 3504(h), Pub. L. 96-511 applies: Not applicable.
9. Abstract: NRC plans to conduct a telephone survey of all licensees of operating commercial nuclear power plants to determine their plans for comply with Title 10 of the Code of Federal Regulations (10 CFR 50.55a(g)(6)(ii)(A) that requires augmented inspections of essentially 100 percent of reactor pressure vessel shell welds. (For the purpose of this augmented examination, "essentially 100 percent" means more than 90 percent of the examination volume of each weld, where the reduction in coverage is due to interference by another component or part geometry.) The primary objectives of the survey are to:
  - (1) Determine if the licensees are aware of the requirement for the augmented examinations.
  - (2) Determine when the licensees intend to perform the augmented examinations and when the required examinations are to be completed.
  - (3) Determine generally how the licensees intend to perform the examinations and what percentage of

the involved welds they anticipate being able to examine.

Copies of the submittal may be inspected or obtained for a fee from the NRC Public Document Room, 2120 L Street, NW. (Lower Level), Washington, DC, 20555.

Comments and questions should be directed to the OMB reviewer: Troy Hillier, Office of Information and Regulatory Affairs (3150-0000) NEOB-3019, Office of Management and Budget, Washington, DC 20503.

Comments can also be submitted by telephone at (202) 395-3084.

The NRC Clearance Office is Brenda Jo. Shelton, (301) 492-8132.

Dated at Bethesda, Maryland, this 8th day of April, 1994.

For the Nuclear Regulatory Commission.

**Gerald F. Cranford,**

*Designated Senior Official for Information Resources Management.*

[FR Doc. 94-9252 Filed 4-15-94; 8:45 am]

**BILLING CODE 7590-01-M**

### Documents Containing Reporting or Recordkeeping Requirements: Office of Management and Budget (OMB) Review

**AGENCY:** Nuclear Regulatory Commission.

**ACTION:** Notice of the OMB review of information collection.

**SUMMARY:** The NRC has recently submitted to OMB for review the following proposal for the collection of information under the provisions of the Paperwork Reduction Act (44 U.S.C. chapter 35).

1. Type of submission, new, revision, or extension: New.
2. The title of the information collection: Application/Permit for Use of the Two White Flint North (TWFN) Auditorium.
3. The form number if applicable: NRC Form 590.
4. How often the collection is required: Each time public use of the auditorium is requested.
5. Who will be required or asked to report: Non-government persons/ organizations.
6. As estimate of the number of responses: 48.
7. An estimate of the total number of hours needed to complete the requirement or request: 12—(.25 hrs. per request).
8. An indication of whether section 3504(h), Public Law 96-511 applies: Not applicable.
9. Abstract: The Nuclear Regulatory Commission will occupy new quarters at Two White Flint North in the Spring

of 1994 that include an auditorium. In accordance with an agreement between Montgomery County and the Nuclear Regulatory Commission, the auditorium will be made available for public use. Public users who wish to use the auditorium will be required to complete NRC Form 590, Application/Permit for Use of Two White Flint North (TWFN) Auditorium. The information is needed to allow for administrative review, - security review, approval of the requester, to facilitate scheduling, and to make a determination that there are no anticipated problems with the requester prior to utilization of the facility.

Copies of the submittal may be inspected or obtained for a fee from the NRC Public Document Room, 2120 L Street, NW., Washington, DC.

Comments and questions can be directed by mail to the OMB reviewer: Troy Hillier, Office of Information and Regulatory Affairs (3150-0000), NEOB-3019, Office of Management and Budget, Washington, DC 20503.

Comments can also be submitted by telephone at (202) 395-3084.

The NRC Clearance Officer is Brenda Jo Shelton, (301) 492-8132.

Dated at Bethesda, Maryland this 8th day of April 1994.

**Gerald F. Cranford,**

*Designated Senior Official for Information Resources Management.*

[FR Doc. 94-9253 Filed 4-15-94; 8:45 am]

**BILLING CODE 7590-01-M**

[Docket Nos. 50-250 and 50-251]

### Florida Power and Light Co.; Issuance of Environmental Assessment and Finding of No Significant Impact

The U.S. Nuclear Regulatory Commission (the Commission or the staff) is considering the issuance of proposed amendments which would change the expiration date for Facility Operating License Nos. DPR-31 and DPR-41 issued to Florida Power and Light Company (the licensee), for operation of the Turkey Point Nuclear Generating Units 3 and 4, (Turkey Point or the facility) located in Dade County, Florida. The proposed amendments would extend the operating license (OL) terms for Turkey Point Units 3 and 4 from April 27, 2007 to July 19, 2012 and to April 10, 2013, respectively.

#### Environmental Assessment

##### Identification of Proposed Action

The currently-licensed term for Turkey Point Units 3 and 4 is 40 years commencing with the issuance of the construction permits (April 27, 1967).



The operating licenses expire on April 27, 2007. Accounting for the time that was required for plant construction, this represents an effective operating license term of approximately 34 years for each unit. By application dated February 25, 1992, the licensee requested recapture of the construction period in the 40-year OL term, thus extending the operating license terms for Turkey Point Units 3 and 4 to July 19, 2012 and April 10, 2013, respectively. The granting of the proposed license amendments would allow the licensee to operate Turkey Point Units 3 and 4 for an addition 5.25 years and 6 years, respectively, beyond the current expiration dates. Additional information in support of the request is provided by the licensee's letters of June 22 and July 13, 1993.

#### *Summary of Environmental Assessment*

The Commission has reviewed the potential environmental impact of the proposed change and issued "Environmental Assessment and Finding of No Significant Impact by the Office of Nuclear Reactor Regulation Related to the Change in Expiration Dates of Facility Operating License Nos. DPR-31 and DPR-41, Florida Power and Light Company, Turkey Point Nuclear Generating Units 3 and 4, Docket Nos. 50-250 and 50-251" dated April 7, 1994. This review considered both the radiological and non-radiological impacts of extended operation compared with those projected in the Turkey Point Final Environmental Statement (FES) dated July 1972. This review evaluated the historical annual collective dose at the facility, dose reduction measures implemented by the licensee, and more recent Commission policy contained in a memorandum from the Executive Director for Operations to the Commission dated August 19, 1982.

#### *Radiological Impacts*

The staff considered potential radiological impacts on the general public residing in the vicinity of the facility and workers at the plant due to normal radiological releases, potential accidents, the uranium fuel cycle, and the transportation of fuel and waste.

The 1990 U.S. Government Census population update shows that the nearest population centers to Turkey Point, all to the west and north beyond a 5-mile radius from the facility, are lower than the population projections in the FES. The FES conservatively estimated a population of 170,000 in the year 1986 within the 10-mile emergency planning zone (EPZ) compared to the U.S. Government Census population update of 105,679 for the year 1990 and

projected population of 144,638 for the year 2013. The exclusion area and nearest population center, and local land usage, are not changed. The site will continue to meet the requirements of 10 CFR part 100. Station radiological effluents to unrestricted areas during normal operation have been well within Commission regulations relating to as-low-as-reasonably-achievable (ALARA) limits, and are indicative of future releases. As a result of low radiological exposure from plant releases during normal operation, low public risk from accidents, and conservative population estimates within the EPZ, the environmental impact findings in the FES are not affected. With regard to station personnel, the licensee complies with Commission guidance and requirements for keeping radiation exposures ALARA for occupational exposures. The licensee will continue to comply with these requirements during the additional years of facility operation and apply advanced technology when available and appropriate. Accordingly, radiological impacts on individuals, both onsite and offsite, are not significantly changed from those previously estimated in the FES and its conclusions remain valid.

The net annualized environmental effects associated with the uranium fuel cycle, which form the basis for Table S-3, "Table of Uranium Fuel Cycle Environmental Data" of 10 CFR 51.51, remain essentially unchanged from those addressed in the FES. The environmental impacts attributable to the transportation of spent fuel and waste from the Turkey Point site with respect to the normal conditions of transport and possible incidents in transport would continue to be as set forth in Summary Table S-4, "Environmental Impact of Transportation of Fuel and Waste to and from One Light Water-Cooled Nuclear Power Reactor" of 10 CFR part 51.52. The combined storage capacity of the two spent fuel pools is 2808 fuel cells and, based upon the licensee's current projections, this capacity will accommodate spent fuel discharges throughout the recaptured operating period for Turkey Point Units 3 and 4.

The estimated additional volume of low-level radioactive waste (LLRW) that would be generated and would require disposal during the approximately 11.25 additional reactor-years of operation is a small fraction of the volume of LLRW that will be produced by the facility during the current authorized operating period. The staff, therefore, concluded that conditions of 10 CFR 51.52(c) will be met and that no new analysis of the environmental effects of transportation

of fuel and waste to and from the reactor is necessary.

#### *Non-Radiological Impacts*

The FES evaluated the non-radiological impacts associated with 40-year facility operation. The assumptions and bases for the FES assessments have not changed and have remained valid throughout the operating period of the facility. The licensee will continue to submit annual non-radiological environmental reports concerning unusual or important events impacting the environment and comply with applicable Federal, State and local agency requirements relating to environmental protection. Compliance with these requirements will preclude any significant non-radiological environmental impacts associated with the proposed action.

#### *Alternative to the Proposed Action*

As an alternative to the proposed action, the staff considered denial of the proposed action. The denial alternative is, in effect, the same as the "no-action" alternative. Denial of the application would result in no change in current environmental impacts since the environmental impacts of the proposed action are insignificant.

#### *Alternative Use of Resources*

This action did not involve the use of any resources not previously considered in the FES dated July 1972, related to operation of the facility.

#### *Agencies and Persons Consulted*

The NRC staff consulted with the State of Florida regarding the environmental impact of the proposed action. The State of Florida had no comments on the proposed action.

#### *Finding of No Significant Impact*

The Commission has reviewed the FES and the additional information provided by the licensee to determine the environmental impact of operation of the facility for the proposed additional 11.25 reactor-years. Based upon the foregoing environmental assessment, the Commission concludes that the proposed action will not have a significant effect on the quality of the human environment. Therefore, the Commission has determined, pursuant to 10 CFR 51.31, not to prepare an environmental impact statement for the proposed action.

For further details with respect to this action, see (1) the application for amendments dated February 25, 1992, and additional information provided by the licensee's letters of June 22, and July 13, 1993, (2) "Final Environmental

Statement Related to the Operation of Turkey Point," Florida Power and Light Company, Docket Nos. 50-250 and 50-251 dated July 1972, and (3) the Environmental Assessment dated April 7, 1994. These documents are available for public inspection at the Commission's Public Document Room, 2120 L Street, NW., Washington, DC and at the local public document rooms located at Florida International University, University Park, Miami, Florida 33199 and at Indian River Community College, Ft. Pierce, Florida.

Dated at Rockville, Maryland, this 7th day of April 1994.

For the Nuclear Regulatory Commission.

**Herbert N. Berkow,**

*Director, Project Directorate II-2, Division of Reactor Projects—II/II, Office of Nuclear Reactor Regulation.*

[FR Doc. 94-9254 Filed 4-15-94; 8:45 am]

BILLING CODE 7590-01-M

### Meeting on Constraint Effects in Fracture Mechanics

**AGENCY:** Nuclear Regulatory Commission.

**ACTION:** Notice of meeting.

**SUMMARY:** The staff of Nuclear Regulatory Commission will meet with its contractors and with other research organizations to discuss recent results and future plans for research addressing crack-tip constraint effects in fracture mechanics and applications to reactor pressure vessel integrity issues.

**DATES:** Wednesday, April 20, 1994, and Thursday, April 21, 1994.

**TIME:** 8 a.m.-5 p.m.

**ADDRESSES:** U.S. Naval Academy, 121 Blake Road, (410) 293-3189 or 4335, Rickover Hall, room R301, Annapolis, Maryland 21402.

#### FOR FURTHER INFORMATION CONTACT:

Mr. Shah N. Malik, Materials Engineering Branch, Office of Nuclear Regulatory Research, Nuclear Regulatory Commission, Washington, DC 20555-0001. Telephone: (301) 492-3842, or 492-3836.

Dated at Rockville, Maryland, this 12th day of April, 1994.

For the Nuclear Regulatory Commission.

**Lawrence C. Shao,**

*Director, Division of Engineering, Office of Nuclear Regulatory Research.*

[FR Doc. 94-9255 Filed 4-15-94; 8:45 am]

BILLING CODE 7590-01-M

[Docket Nos. STN 50-454, STN 50-455, STN 50-456 and STN 50-457].

### Commonwealth Edison Co., Byron Station, Unit Nos. 1 and 2, et al.; Biweekly Notice Applications and Amendments To Operating Licenses Involving No Significant Hazards Considerations Correction

In notice document 94-5971 beginning on page 12356, in the issue of Wednesday, March 16, 1994, make the following correction:

In the third column, the first full notice, on page 12375, in the line reading "Amendment Nos.: 47, 47, 59, and 59" correct to read "Amendment Nos.: 58, 58, 46 and 46".

Dated at Rockville, Maryland this 11th day of April 1994.

For the Nuclear Regulatory Commission.

**George F. Dick, Jr.,**

*Project Manager, Project Directorate III-2, Division of Reactor Projects—III/IV/V, Office of Nuclear Reactor Regulation.*

[FR Doc. 94-9256 Filed 4-15-94; 8:45 am]

BILLING CODE 7590-01-M

[Docket No. 40-8681]

### Umetco Minerals Corporation, White Mesa Mill

**AGENCY:** U.S. Nuclear Regulatory Commission.

**ACTION:** Notice of receipt of a request to amend Source Material License SUA-1358 to receive and dispose of approximately 2.6 million cubic yards of materials from the Department of Energy's Monticello Tailings Project.

#### 1. Proposed Action

By letter dated March 25, 1994, Umetco Minerals Corporation, holder of Source Material License SUA-1358 for the White Mesa Mill, requested an amendment to their license to allow receipt and disposal of materials from the Department of Energy's Monticello Tailings Project.

#### 2. Reason for Request to Amend License

Umetco Minerals Corporation owns and operates a uranium milling facility in San Juan County, Utah. The mill is licensed to produce 4380 tons of U<sub>3</sub>O<sub>8</sub> per calendar year. Currently the mill is not in production. The Department of Energy has notified Umetco Minerals Corporation that they have been selected as the primary alternative site for the permanent receipt and disposal of the Monticello Tailings material. The materials would be disposed of in a dry state in Cell 4A and Cell 3 of the present tailings impoundment system. The composition of the materials would be

uranium and vanadium mill tailings, mill structures, vicinity property cleanup materials, and a small amount of uranium-vanadium ore samples. The Department of Energy has committed to Umetco that no shipments of RCRA materials would be made to the White Mesa Mill.

### 3. Notice of Opportunity to Request Hearing

In accordance with Title 10, Code of Federal Regulations, part 2 (10 CFR part 2), § 2.1205(c)(1), interested parties are hereby notified that they may request a hearing pursuant to the procedures set forth in 10 CFR 2.1205 within 30 days of the publication of this notice. Upon completion of the NRC staff's review of the requested amendment, notice of the action to be taken by published in the Federal Register for information.

Signed in Denver, Colorado, this 1st day of April 1994.

**Edward F. Hawkins,**

*Deputy Director, Uranium Recovery Field Office, Region IV.*

[FR Doc. 94-9257 Filed 4-15-94; 8:45 am]

BILLING CODE 7590-01-M

### PHYSICIAN PAYMENT REVIEW COMMISSION

#### Commission Meeting

**AGENCY:** Physician Payment Review Commission.

**ACTION:** Notice of meeting.

**SUMMARY:** The Commission will hold its next public meeting on Monday, May 2, and Tuesday, May 3, 1994 at the Embassy Suites Downtown Hotel, 1250 22nd Street NW., Washington, DC, in the Consulate Room. The meetings are tentatively scheduled to begin at 9 a.m. each day. The Commission will review draft reports on access to care for Medicare beneficiaries, setting volume performance standards and updating the Medicare Fee Schedule conversion factor for 1995, and Medicare beneficiary financial liability. Other topics for discussion could include the Medicare risk contracting program, payment for trauma services, selecting residency programs to be funded on the basis of educational quality, and technology assessment and coverage decisions. A final agenda will be available on April 25, 1994.

**ADDRESSES:** Please note that the Commission has a new address: 2120 L Street, NW./suite 200/Washington, DC 20037. The telephone number is the same: 202/653-7220.

**FOR FURTHER INFORMATION CONTACT:** Lauren LeRoy, Deputy Director, or

Annette Hennessey, Executive Assistant, at 202/653-7220.

**SUPPLEMENTARY INFORMATION:** Agendas for the meeting will be available on Monday, April 25, 1994 and will be mailed out at that time. To receive an agenda, please direct all requests to the receptionist at 202/653-7220.

Paul B. Ginsburg,

Executive Director.

[FR Doc. 94-9266 filed 4-15-94; 8:45 am]

BILLING CODE 6820-SE-M

## SECURITIES AND EXCHANGE COMMISSION

[Release No. 34-33893; File No. SR-OCC-92-13]

### Self-Regulatory Organizations; The Options Clearing Corporation; Notice of Amendment to Filing and Order Granting Accelerated Approval to Proposed Rule Change Amending the Valuation Rate Applied to Securities Deposited as Clearing Margin

April 14, 1994.

On May 4, 1992, The Options Clearing Corporation ("OCC") filed with the Securities and Exchange Commission ("Commission") a proposed rule change pursuant to section 19(b) of the Securities Exchange Act of 1934 ("Act")<sup>1</sup> relating to the valuation of securities deposited as clearing margin (File No. SR-OCC-92-13). On June 8, 1992, OCC filed a technical amendment with the Commission.<sup>2</sup> Notice of the proposal appeared in the Federal Register on September 17, 1992, to solicit comment from interested persons.<sup>3</sup> Two comments letters supporting the proposal were received by the Commission.<sup>4</sup> On March 9, 1994, OCC again filed an amendment with the Commission.<sup>5</sup> The Commission is publishing this notice and order to solicit comments on the amendment to the filing and to approve the amended proposal on an accelerated basis.

<sup>1</sup> 15 U.S.C. 78s(b) (1988).

<sup>2</sup> For a description of the June 8, 1992, amendment, refer to note 9.

<sup>3</sup> Securities Exchange Act Release No. 31169 (September 10, 1992), 57 FR 43041.

<sup>4</sup> Letters from Robert D. Noble, Principal, Morgan Stanley & Co., Incorporated, to Gerry [sic] Carpenter, Division of Market Regulation (December 15, 1993); and Anthony Miserandino, Chairman, Options Operations Committee, National Options and Futures Society, to Gerry [sic] Carpenter, Division of Market Regulation (December 23, 1993).

<sup>5</sup> For a discussion of the March 9, 1994, amendment, refer to note 11.

## I. Description of the Proposal

### A. The Proposal

The proposed rule change amends the rate used to value equity and corporate debt issues deposited for clearing margin purposes pursuant to OCC Rule 604(d)(1).<sup>6</sup> Currently, OCC Rule 604(d)(1) provides that deposited stock and convertible bonds shall be valued on a daily basis at the maximum loan value permitted under the provisions of Regulation U of the Board of Governors of the Federal Reserve System ("FRB")<sup>7</sup> or at such lower value as the OCC Membership/Margin Committee may prescribe, and that non-convertible debt shall be valued on a daily basis at 70% of current market value or at such lower value as the Membership/Margin Committee may prescribe.<sup>8</sup> Interpretations and Policies ("I&P")<sup>9</sup> to OCC Rule 604 currently provides that for clearing margin purposes equity and debt issues shall not be valued in excess of 50% of current market value.<sup>9</sup> The proposal permits OCC to value deposits of stocks and bonds<sup>10</sup> at 60% of current market value or at such lower rate as determined by OCC's Membership/Margin Committee.<sup>11</sup>

<sup>6</sup> OCC Rule 604(d)(1) sets forth the requirements for the use of preferred and common stock and corporate debt issues as forms of margin. In addition to these valued securities, Rule 604 permits OCC to accept U.S. Government securities and letters of credit in lieu of cash margin.

<sup>7</sup> 12 CFR 221 (1993). Section 221.8. (a) of Regulation U [12 CFR 221.8. (a) (1993)] provides that the maximum loan value of margin stocks, other than options, is fifty per cent of their current market value.

<sup>8</sup> The OCC Membership/Margin Committee is a committee of six members of the OCC Board of Directors that reviews membership applications and makes margin policy. Telephone conversation between Jean M. Cawley, Staff Counsel, OCC, and Thomas C. Etter, Jr., Attorney, Division of Market Regulation ("Division"), Commission (May 7, 1992).

<sup>9</sup> In its June 8, 1992, amendment, OCC notes that an I&P .09 to Rule 604 was approved by the Commission in Securities Exchange Act Release No. 29576 (August 16, 1991), 56 FR 41873 [File No. SR-OCC-88-03] (order approving proposed rule change involving valued securities program), but because of an oversight, it was never included in OCC's rule book. As a result, a later I&P to Rule 604, which was approved by the Commission in Securities Exchange Act Release No. 29920 (November 15, 1991), 56 FR 58105 [File No. SR-OCC-91-04] (order approving proposed rule change relating to cross-rate foreign currency options), was entered into OCC's rule book as I&P .09. Thus, there are currently two I&Ps to Rule 604 which were filed and approved as .09. The June 8, 1992, amendment corrects this misnumbering.

<sup>10</sup> The filing also amends OCC Rule 604(d) so that both convertible and non-convertible corporate bonds are treated consistently for margin purposes and are referred to simply as corporate bonds.

<sup>11</sup> The March 9, 1994, amendment modified the loan value rate from 70% to 60% of the current market value. Letter from Jean M. Cawley, Associate Counsel, OCC to Jerry W. Carpenter, Chief, Branch of Clearing Agency Regulation, Division of Market Regulation (March 8, 1994). The initial proposal had called for increasing the loan value to 70%.

OCC also is amending its Rule 705, which describes the forms of margin that may be deposited for cross-margin obligations, to provide that common stock may be deposited as margin only if mutually acceptable to OCC and the participating commodities clearing organization ("CCO"). Such deposits, if acceptable, will be valued in accordance with the cross-margining agreement between OCC and the participating CCO. This amendment is intended to preserve OCC's and the participating CCO's rights to determine whether they will accept common stock as a form of margin collateral, and it provides a means for OCC and the participating CCO to value these deposits without requiring OCC to further amend Rule 705.

### B. OCC's Valued Securities Program

In 1975, OCC proposed to institute a program through which it would accept deposits of common stocks as clearing margin collateral ("valued securities program") under Rule 604(d).<sup>12</sup> The novelty of the proposed program, however, resulted in extensive regulatory review by the staffs of the FRB and the Commission. As a result of this review process, several significant changes were made to the OCC valued securities program that the Commission subsequently approved in 1982.<sup>13</sup> In 1983, the Commission approved a proposal whereby OCC was authorized to expand the types of stocks that clearing members could deposit to meet their clearing margin obligations.<sup>14</sup> Pursuant to that amendment, however, clearing members are permitted to deposit only stocks that have a market value of greater than \$10 a share and either (1) are traded on a national

<sup>12</sup> Securities Exchange Act Release No. 11820 (November 12, 1975), 40 FR 53637 [File No. SR-OCC-75-05] (notice of proposed rule change). This submission did not receive Commission approval. In fact, because of the filing's potential conflicts with FRB regulations, including Regulation T [12 CFR 220], OCC requested that File No. SR-OCC-75-05 be withdrawn and submitted File No. SR-OCC-82-11 in its place. Securities Exchange Act Release No. 18994 (August 20, 1982), 47 FR 37731 [File No. SR-OCC-82-11] (order approving File No. SR-OCC-82-11 and withdrawing File No. SR-OCC-75-05).

<sup>13</sup> The valued securities program, as approved, amended OCC Rule 604 to allow OCC clearing members to meet their clearing margin obligations with OCC by depositing common stocks underlying listed options that were not being used as cover for existing options positions. Previously, Rule 604 had limited clearing margin collateral to cash, government securities, or letters of credit. Securities Exchange Act Release No. 18994 (August 20, 1982), 47 FR 37731 [File No. SR-OCC-82-11] (order approving File No. SR-OCC-82-11 and withdrawing File No. SR-OCC-75-05).

<sup>14</sup> Securities Exchange Act Release No. 20558 (January 13, 1984), 49 FR 2183 [File No. SR-OCC-83-17].

securities exchange that has last sale reports collected and disseminated pursuant to a consolidated transaction reporting plan or (2) are traded in the over-the-counter market and are designated as a National Market System security.<sup>15</sup> The proposal also established that such deposits are to be valued at the lesser of the maximum loan value prescribed by the FRB in Regulation U for margin stocks or 70% of current market value.<sup>16</sup>

In 1991, the Commission authorized OCC to add preferred stock and corporate debt to the valued securities program.<sup>17</sup> To be eligible for deposit as clearing margin collateral, preferred stock has to meet the same eligibility standards as those previously approved for common stocks. Corporate bonds are required to be listed on a national securities exchange, to not be in default, and to have a current market value that is readily determinable on a daily basis. The maximum loan value for preferred stocks and corporate debt also was set at 50% of current market value.<sup>18</sup>

OCC states in its filing that it has accepted deposits of common stock as clearing margin since 1982 and preferred stock and corporate debt since 1991 and that, accordingly, it has gained substantial experience in operating its valued securities program. OCC claims that the valued securities program has been successful in (1) reducing OCC's reliance on letters of credit by expanding acceptable forms of margin deposits and (2) enhancing the efficient allocation of clearing member capital.<sup>19</sup>

OCC further states in its filing that from the program's commencement clearing members have requested that deposits of securities be valued at greater than 50% of current market value. OCC has been unable to

accommodate these requests because of its agreement with the staffs of the FRB and the Commission that the OCC clearing margin would be capped at the maximum loan rate provided by Regulation U for margin securities. In response to OCC's filing, the FRB's staff has stated that the FRB will not object to an increase in the valuation rate applied to OCC's deposits of debt and equity issues.<sup>20</sup> OCC proposes to value stocks and bonds deposited as clearing margin at a maximum of 60% of current market value or at such lesser value as OCC's Membership/Margin Committee may prescribe from time to time.

OCC states that in addition to the 60% valuation rate providing a safe level of protection for OCC, there are additional safeguards in place for its protection. These safeguards include:

(1) The Commission's Uniform Net Capital Rule, which applies to OCC clearing members;<sup>21</sup>

(2) The authority of OCC's Membership/Margin Committee to prescribe a lower valuation rate from time to time; and

(3) OCC Rule 604(d)(1) which, among other things, establishes high eligibility standards for securities in the valued securities program and limits deposits of valued securities program and limits deposits of valued securities issued by any one issuer to 10% of the margin requirement of the account for which the securities are deposited.

## II. Discussion

The Commission believes that the proposal is consistent with the Act and particularly with Section 17A of the Act.<sup>22</sup> Section 17A(b)(3)(F) of the Act<sup>23</sup> requires that the rules of a clearing agency be designed to assure the safeguarding of funds in the custody or control of the clearing agency or for which it is responsible.

The Commission believes that the effective functioning of the OCC valued securities program and OCC's various financial safeguards and risk monitoring systems,<sup>24</sup> taken as a whole, suggest that

an increase in the valuation rate for securities deposited as clearing margin should not detract from OCC's ability to safeguard securities and funds for which it is responsible. Increasing the valuation rate also should help reduce OCC's reliance on letters of credit as margin collateral.<sup>25</sup>

The Commission also finds good cause for approving the proposed rule change prior to the thirtieth day after the date of publication of notice of the filing of the amendment. Because the comment letters the Commission received to OCC's proposal as originally filed were in favor of increasing the valuation rate from 50% to 70% for equity and corporate debt issues deposited for clearing margin, the Commission does not foresee receiving any adverse comment letters with regard to the March 9, 1994, amendment which amended the filing to increase the valuation rate from 50% to 60%.

## III. Solicitation of Comments

Interested persons are invited to submit written data, views, and arguments concerning the foregoing. Persons making written submissions should file six copies thereof with the Secretary, Securities and Exchange Commission, 450 Fifth Street, NW., Washington, DC 20549. Copies of the submission, all subsequent amendments, all written statements with respect to the proposed rule change that are filed with the Commission, and all written communications relating to the proposed rule change between the Commission and any person, other than those that may be withheld from the public in accordance with the provisions of 5 U.S.C. 552, will be

issued that can be held in an account to 10% of the margin requirement for the account;

(3) OCC's ability to monitor adequately the value of margin deposits on a daily basis;

(4) The Theoretical Intermarket Margining System ("TIMS"), which employs option price theory to identify and measure market risk and to calculate margin requirements;

(5) The Concentration Monitoring System, which enables OCC to analyze and address risks resulting from concentrated, undiversified options portfolios; and

(6) The Risk Management System, which generally allows OCC to evaluate the risks associated with the entire stock, options, and futures portfolios held by its clearing members.

<sup>25</sup> The financial reliability of these credit agreements depends on the creditworthiness of their issuers, and a clearing agency holding letters of credit as clearing margin may be exposed to risk in event of an issuer default or insolvency. Also, payment on letters of credit can be subject to delay, depending on the terms of the letter of credit and the timing of the default. See Securities Exchange Act Release No. 30883 (July 1, 1992), 57 FR 30521 [File No. SR-NSCC-92-05] (order approving limitations on letter of credit clearing fund contributions).

<sup>15</sup> *Id.*

<sup>16</sup> Pursuant to Regulation U, the maximum loan value for margin stocks was then and currently is 50% of current market value.

<sup>17</sup> Securities Exchange Act Release No. 29576 (August 16, 1991), 56 FR 41873 [File No. SR-OCC-88-03] (order approving proposed rule change).

<sup>18</sup> Regulation U defines "margin stock" to include convertible debt and thus subjects convertible debt to the 50% loan value limitation. [12 CFR 221.2.(h)(4) and 221.8.(a)]. Regulation U does not include non-convertible debt in its definition of margin stock, and therefore, non-convertible debt is subject to "good faith loan value." [12 CFR 221.8.(b)]. Nevertheless, the OCC filing proposing the inclusion of preferred stock and corporate debt, File No. SR-OCC-88-03, included OCC's I&P .09 to Rule 604 which prescribes that the 50% loan value limitation applies to all debt and equity securities involved in the valued securities program.

<sup>19</sup> OCC states that because margin securities are the major source of collateral for letters of credit, its valued securities program was designed to eliminate the intermediate step of clearing members' depositing margin securities at banks as collateral for the issuance of letters of credit.

<sup>20</sup> Telephone conversation between Scott Holz, Senior Attorney, Division of Banking Supervision and Regulation, FRB, and Thomas C. Etter, Jr., Esq., Division, Commission (March 3, 1993) and letter from Scott Holz to Thomas C. Etter, Jr. (March 11, 1993).

<sup>21</sup> Act Rule 15c3-1 [17 CFR 240.15c3-1 (1993)].

<sup>22</sup> 15 U.S.C. 78q-1 (1988).

<sup>23</sup> 15 U.S.C. 78q-1(b)(3)(F) (1988).

<sup>24</sup> As discussed above, numerous financial safeguards and risk reduction systems already employed by OCC will continue to be used by OCC under this proposal. Among others, these include:

(1) The valued securities program eligibility standards for stock and corporate debt;

(2) The valued securities program concentration ratio, which limits the amount of stock of any one

available for inspection and copying in the Commission's Public Reference Section, 450 Fifth Street, NW., Washington, DC 20549. Copies of such filing will also be available for inspection and copying at the principal office of OCC. All submissions should refer to File No. SR-OCC-92-13 and should be submitted by May 9, 1994.

#### IV. Conclusion

For the reasons discussed above, the Commission believes that the amended proposal is consistent with the requirements of the Act, particularly with those of section 17A of the Act, and the rules and regulations thereunder.

It is therefore ordered, pursuant to section 19(b)(2) of the Act,<sup>26</sup> that the above-mentioned proposed rule change (File No. SR-OCC-92-13) be, and hereby is, approved.

For the Commission by the Division of Market Regulation, pursuant to delegated authority.<sup>27</sup>

Margaret H. McFarland,  
Deputy Secretary.

[FR Doc. 94-9269 Filed 4-15-94; 8:45 am]

BILLING CODE 8010-01

[Release No. 34-33894; International Series Release No. 649; File No. SR-AMEX-93-32]

### Self-Regulatory Organizations; Order Approving and Notice of Filing and Order Granting Accelerated Approval to Amendment Nos. 1, 2, and 3 to Proposed Rule Change by the American Stock Exchange, Inc. Relating to a Proposal To List for Trading Options and Long-Term Options on the Amex Hong Kong Option Index

April 11, 1994.

#### I. Introduction and Background

On October 27, 1993, the American Stock Exchange, Inc. ("Amex" or "Exchange") submitted to the Securities and Exchange Commission ("SEC" or "Commission"), pursuant to section 19(b)(1) of the Securities Exchange Act of 1934 ("Act"),<sup>1</sup> and Rule 19b-4 thereunder,<sup>2</sup> a proposed rule change to list for trading options based on the Hong Kong Option Index ("Hong Kong Option Index" or "Index")—an index comprised of Hong Kong stocks traded on the Stock Exchange of Hong Kong ("HKSE"). The Amex amended the proposal on February 10, 1994, March

10, 1994, and April 8, 1994.<sup>3</sup> Notice of the proposal to approve Index options for listing and trading appeared in the *Federal Register* on December 15, 1993 ("Notice").<sup>4</sup> No comments were received on the proposed rule change set forth in the Notice. This order approves the Exchange's proposal.

#### II. Description of the Proposal

The Amex proposes to trade standardized index option contracts based on the Hong Kong Option Index. The Amex also intends to list long-term options on the full-value Index, or long-term options on a reduced-value Index that will be computed at one-tenth of the value of the Index. Recently, the Commission approved an Amex rule proposal to list and trade warrants based on the Amex Hong Kong 30 Index,<sup>5</sup> which is based entirely on the market capitalization of thirty companies traded on the HKSE. The Amex also proposes to amend Rule 904(b) to provide for a position limit of 25,000 contracts on the same side of the market, provided no more than 15,000 of such contracts are in series in the nearest expiration month.

##### A. Description of the Hong Kong Option Index

The Hong Kong Option Index is identical to the Amex Hong Kong 30 Index,<sup>6</sup> except that the Hong Kong

<sup>3</sup> On February 10, 1994, the Amex amended its proposal to: (1) change the name of the Index for standardized options from the "Amex Hong Kong 30 Index" to the Hong Kong Option Index; (2) establish an Index level in the range of 150 to 250; and (3) list 2½ point strike price intervals in the event the Index level is below 200. (See letter from Howard A. Baker, Senior Vice President, Derivative Securities, Amex to Howard L. Kramer, Associate Director, Division of Market Regulation, SEC, dated February 10, 1994 ("Amendment No. 1").) On March 10, 1994, the Amex amended its proposal to establish a Hong Kong Option Index level equal to 0.40 times the Amex Hong Kong 30 Index. See letter from Nathan Most, Senior Vice President, New Products Development, Amex to Howard L. Kramer, Associate Director, Division of Market Regulation, SEC, dated March 10, 1994 ("Amendment No. 2"). On April 8, 1994, the Amex amended its proposal to limit the use of its Auto-Ex system to fifty contracts for market and marketable limit orders in options on the Hong Kong Option Index. See letter from Claire P. McGrath, Managing Director and Special Counsel, Derivative Securities, Amex to Michael Walinskas, Branch Chief, Division of Market Regulation, SEC, dated April 8, 1994 ("Amendment No. 3").

<sup>4</sup> Securities Exchange Act Release No. 33308, (December 9, 1993), 58 FR 65607.

<sup>5</sup> Securities Exchange Act Release No. 33036 (October 8, 1993), 58 FR 53588. The Hong Kong Option Index will be identical to the Amex Hong Kong 30 Index, except for its index level. See *supra* note 3.

<sup>6</sup> See Amendment No. 2, *supra* note 3. The Amex originally established the Amex Hong Kong 30 Index in order to list and trade warrants based on an index designed to represent a substantial segment of the Hong Kong stock market. See

Option Index has a different index level, which was recently set at 0.40 times that of the Amex Hong Kong 30 Index.<sup>7</sup> The Hong Kong Option Index is a capitalization-weighted stock index designed and maintained by the Amex, and based on the capitalizations of 30 stocks that are traded on the HKSE and whose issuers have major business interests located in Hong Kong.<sup>8</sup> The HKSE is the primary trading market for 25 of the 30 Index component stocks, while the primary trading market for all of the Index component stocks is either Hong Kong or London.<sup>9</sup>

Since the Exchange created the Hong Kong 30 Index on June 25, 1993, its level has risen from an initial 350 to a current range of 570-600. In late December 1993 and early January 1994, the Amex Hong Kong 30 Index approached the 640 level, before falling to its present level after a recent downturn in the Hong Kong market.<sup>10</sup> The Amex has stated its concern that introducing options at an index level and volatility as high as that of the Amex Hong Kong 30 Index would create very high premiums on near-term series, and that this concern justifies a lower index level for options. Because the Amex Hong Kong 30 Index serves as the basis for warrant issues, the Amex will continue to calculate and disseminate the Amex Hong Kong 30 Index at its current level, retaining the ticker symbol "HKX", since it serves as the basis for the Index warrant issues.<sup>11</sup> The Hong Kong Option Index, which will serve as the basis for standardized options trading, will use the ticker symbol "HKO" (or similar symbol) for both standardized options trading and the underlying Index level.<sup>12</sup> The Amex has set the Index level at 0.40 times that of the Amex Hong Kong 30 Index.<sup>13</sup>

As of February 28, 1994, the total capitalization of the Index was US\$222.214 billion.<sup>14</sup> Market capitalizations of the individual stocks in the Index ranged from high of US\$25.101 billion to a low of US\$519

Securities Exchange Act Release No. 33036, *supra* note 5.

<sup>7</sup> See Amendment No. 2, *supra* note 3.

<sup>8</sup> The Amex has represented that it will not include in the Index any component stock whose issuer is an entity formed and governed under the laws of the People's Republic of China. See letter from Nathan Most, Senior Vice President, New Products Development, Amex to Richard Zack, Division of Market Regulation, SEC, dated September 7, 1993.

<sup>9</sup> See Amendment No. 2, *supra* note 3.

<sup>10</sup> See Amendment No. 1, *supra* note 3.

<sup>11</sup> See Securities Exchange Act Release No. 33036, *supra* note 5; Amendment No. 1, *supra* note 3.

<sup>12</sup> Amendment No. 1, *supra* note 3.

<sup>13</sup> See Amendment No. 2, *supra* note 3.

<sup>14</sup> Based on the February 28, 1994 exchange rate of HK\$7.726 to US\$1.00.

<sup>26</sup> 15 U.S.C. 78s(b)(2) (1988).

<sup>27</sup> 17 CFR 200.30-3(a)(12) (1993).

<sup>1</sup> 15 U.S.C. 78s(b)(1) (1982).

<sup>2</sup> 17 CFR 240.19b-4 (1993).

million, with the median being US\$5.140 billion. The total number of shares outstanding for the stocks in the Index ranged from a high of approximately 11.152 billion shares to a low of 561.392 million shares. The price per share of the stocks in the Index, as of February 28, 1994, ranged from a high of US\$14.76 to a low of US\$0.76. In addition, the average daily trading volume of the stocks in the Index, for the six-month period ending February 28, 1994, ranged from a high of 16.826 million shares to a low of 1.449 million shares, with the median being 3.579 million shares. The highest weighted component stock in the Index accounts for 11.30% of the Index. The five largest Index components account for approximately 43.18% of the Index's value. The lowest weighted component stock comprises 0.23% of the Index.<sup>15</sup>

#### *B. Eligibility Standards for the Inclusion and Maintenance of Component Stocks in the Index*

The Amex states that it selects securities comprising the Index based on their market weight, trading liquidity, and representativeness of the business industries reflected on the HKSE. The Amex will require that each Index component security be one issued by an entity with major business interests in Hong Kong, listed for trading on the HKSE, and have its primary trading market located in a country with which the Amex has an effective surveillance sharing agreement. The Amex will remove any Index component security that fails to meet any of the foregoing listing and maintenance criteria within 30 days after such a failure occurs.

To ensure that the Index does not consist of a number of thinly-capitalized, low-priced securities with small public floats and low trading volumes, the Amex has established additional listing and maintenance criteria:

(1) All component securities selected for inclusion in the Index must have, and thereafter maintain, an average daily capitalization, as calculated by the total number of shares outstanding times the latest price per share (in Hong Kong dollars), measured over the prior six month period, of at least HK\$3 billion (approximately US\$380 million);

(2) All component securities selected for inclusion in the Index must have, and thereafter maintain, a minimum free float value (total freely tradeable outstanding shares less insider holdings), based on a monthly average measured over the prior three month

period, of US\$238 million, although up to, but no more than, three Index component securities may have a free float value of less than US\$238 million but in no event less than US\$150 million, measured over the same period;

(3) All component securities selected for inclusion in the Index must have, and thereafter maintain, an average daily closing price, measured over the prior six month period, not lower than HK\$2.50 (approximately US\$0.32); and

(4) All component securities selected for inclusion in the Index must have, and thereafter maintain, an average daily trading volume, measured over the prior six month period, of more than one million shares per day, although up to, but no more than, three component securities may have an average daily trading volume, measured over the prior six month period, of less than one million shares per day.

Beginning in 1994, the Amex will review the Index's component securities on a quarterly basis, conducted on the last business day in January, April, July, and October. Any component security failing to meet the above listing and maintenance criteria will be reviewed on the second Friday of the second month following the quarterly review again to determine compliance with the above criteria. Any Index component stock failing this second review will be replaced by a "qualified" Index component stock effective upon the close of business on the following Friday, provided, however, that if such Friday is not a business day, the replacement will be effective at the close of business on the first preceding business day. The Amex will notify its membership immediately after it determines to replace an Index component stock.<sup>16</sup>

The Index will be maintained by the Amex and will contain at least thirty component stocks at all times. Pursuant to Exchange Rule 901C(b), the Amex may change the composition of the Index at any time in order to reflect more accurately the composition and track the movement of the Hong Kong stock market. Any replacement component stock must also meet the component stock listing and maintenance standards as discussed above. If the number of Index component securities in the Index falls below thirty, no new option series based on the Index will be listed for trading unless and until the Commission

<sup>16</sup> Listing and maintenance standards for the Index are identical to those originally established for the Amex Hong Kong 30 Index. See Securities Exchange Act Release No. 33036, *supra* note 5.

approves a rule filing pursuant to section 19(b) of the Act reflecting such change.

At the close of the market on February 28, 1994, the average closing price of the component stocks of the Index was HK\$30.70 (US\$3.97), with the highest price stock closing at HK\$114.00 (US\$14.76) and the lowest price stock closing at HK\$5.85 (US\$0.76). On that same date, of the thirty component stocks included in the Index, four closed at prices lower than HK\$7.50, or approximately US\$1.00. As of February 28, 1994, the total market capitalization of the Index component stocks was US\$222.214 billion.<sup>17</sup>

#### *C. Calculation and Settlement of Index*

The Hong Kong Option Index is a capitalization-weighted index the value of which is calculated by multiplying the price of each component security (in Hong Kong dollars) by the number of shares outstanding of each such security, adding the sums and dividing by the current Index divisor. The Amex has set the Index level at 202.628 at the close of the market on March 10, 1994. The Amex calculated the Index level by taking the Amex Hong Kong 30 Index, which was at a level of 506.57 on March 10, 1994, and multiplying it by 0.40.<sup>18</sup>

Because the HKSE does not operate during the Amex's trading hours, the Amex calculates the Index once each day based on the most recent official closing price of each Index component security as reported by the HKSE. The Amex will administer the Index, making such adjustments to the divisor as may be necessary in light of stock splits, stock replacements, or other corporate actions which would cause a discontinuity in the Index value. The Index value is being published through the Exchange's market data system and will be made available to vendors.<sup>19</sup>

#### *D. Expiration and Settlement*

The Exchange's proposed options on the Index are to be European-style (*i.e.*, exercises are permitted at expiration only) and cash-settled. Standard option trading hours for broad-based index options (9:30 a.m. to 4:15 p.m. New York time) will apply. Options on the

<sup>17</sup> Based on the February 28, 1994 exchange rate of HK\$7.726 to US\$1.00.

<sup>18</sup> See amendment No. 2, *supra* note 3. When the Amex first proposed listing and trading options based on the Amex Hong Kong 30 Index, the Amex intended to use the same Index level as that used for warrants on that index. Securities Exchange Act Release No. 33308, *supra* note 4. Currently, the Amex Hong Kong 30 Index is at a level of about 500. See Amendment No. 2, *supra* note 3.

<sup>19</sup> For a more detailed description of Index pricing, see Securities Exchange Act Release No. 33036, *supra* note 5.

<sup>15</sup> Amendment No. 2, *supra* note 3.

Index will expire on the Saturday following the third Friday of the expiration month ("Expiration Friday"). The last trading day in an option series will normally be the second to last business day preceding the Saturday following the third Friday of the expiration month (normally at Thursday). Trading in expiring options will cease at the close of trading on the last trading day. The exercise settlement value for all of the Index's expiring options will be calculated based upon the most recent official closing price of each of the component securities as reported by the HKSE on the last trading day prior to expiration.

The Exchange plans to list options series with expirations in the three near-term calendar months and in the two additional calendar months in the March cycle. In addition, longer term option series having up to thirty-six months to expiration may be traded.<sup>20</sup> In lieu of such long-term options on a full-value Index level, the Exchange states that it may instead list long-term, reduced-value put and call options which will be computed by dividing the value of the full-value Index by 10 and rounding the resulting figure to the nearest one-hundredth. The interval between expiration month for either full-value or reduced-value long-term options will not be less than six months. The strike price interval for reduced-value Index options will be no less than \$2.50 instead of \$5.00.

#### E. Applicable Options Rules

Options on the Index, including long-term options based on the full or a reduced-value Index, will be governed by Exchange Rules 900 C through 980C. These rules govern matters such as disclosure, account approval and suitability, position and exercise limits, margin, trading halts and suspensions, and floor procedures. Surveillance procedures currently used by the Exchange to monitor trading in each of the Exchange's other index options will also be used to monitor trading in regular and long-term options on the Index. The Index is deemed by the Exchange to be a Stock Index Option under Amex Rule 901C(a), and a Broad Stock Index Group under Amex Rule 900C(b)(1).

The Exchange seeks to list near-the-money (*i.e.*, within ten points above or below the current index value) option series on the Index at 2½ point strike (exercise) price intervals when the value of the Index is below 200 points. The Exchange has also proposed to amend Rule 904C(b) to establish a position

<sup>20</sup> See Amex Rule 903C(a).

limit of 25,000 contracts on the same side of the market, provided no more than 15,000 of such contracts are in series in the nearest expiration month.

The Exchange states that it expects the Hong Kong Option Index to attract a substantial number of customers, including institutional activity, and is therefore seeking Commission approval permitting it to use its Auto-Ex system for orders in the Index options of up to 50 contracts.<sup>21</sup> Auto-Ex is the Exchange's automated execution system which provides for the automatic execution of market and marketable limit orders at the best bid or offer at the time the order is entered.

#### III. Discussion

The Commission finds that the proposed rule change is consistent with the requirements of the Act and the rules and regulations thereunder applicable to a national securities exchange and, in particular, the requirements of section 6(b)(5) of the Act.<sup>22</sup> Specifically, the Commission finds that the trading of options based on the Hong Kong Option Index, including long-term options based on either the full or a reduced-value of the Index, will serve to protect investors, promote the public interest, and help to remove impediments to a free and open securities market by providing investors with a means to hedge exposure to market risk associated with the Hong Kong equity market and provide a surrogate instrument for trading in the Hong Kong securities market.<sup>23</sup> In particular, Hong Kong Option Index options will benefit U.S. investors by allowing them to obtain differential rates of return on a capital outlay if the Hong Kong Option Index moves in a favorable direction within a specified time period. Of course, if the Hong Kong Option Index moves in the wrong direction or fails to move in the right direction, the options expire worthless and the investors will have lost their entire investment. Thus, the trading of options based on the Hong Kong Option Index will provide investors with a valuable hedging vehicle that should

<sup>21</sup> Amendment No. 3, *supra* note 3. The Amex originally proposed permitting the use of its Auto-Ex system for orders in the Index options of up to 99 contracts.

<sup>22</sup> 15 U.S.C. 78f(b)(5) (1988).

<sup>23</sup> Pursuant to Section 6(b)(5) of the Act, the Commission must predicate approval of any new securities product upon a finding that the introduction of such product is in the public interest. Such a finding would be difficult with respect to an option that served no hedging or other economic function, because any benefits that might be derived by market participants likely would be outweighed by the potential for manipulation, diminished public confidence in the integrity of the markets, and other valid regulatory concerns.

reflect accurately the overall movement of the Hong Kong equity market.

Nevertheless, the trading of options based on the Index, including long-term options based on either the full or a reduced-value of the Index, raises several concerns, namely issue related to customer protection, index design, surveillance, and market impact. The Commission believes, for the reasons discussed below, that the Amex has adequately addressed these concerns.

#### A. Customer Protection

The Commission believes that a regulatory system designed to protect public customers must be in place before the trading of sophisticated financial instruments, such as Hong Kong Option Index options, can commence on a national securities exchange. The Commission notes that the trading of standardized exchange-traded options occurs in an environment that is designed to ensure, among other things, that: (1) The special risks of options are disclosed to public customers; (2) only investors capable of evaluating and bearing the risks of options trading are engaged in such trading; and (3) special compliance procedure are applicable to options accounts. Accordingly, because the Index options will be subject to the same regulatory regime as the other standardized options currently traded on the Amex, the Commission believes that adequate safeguards are in place to ensure the protection of investors in Index options.

#### B. Index Design and Structure

The Commission finds that it is appropriate and consistent with the Act to classify the Index as a broad-based index. In addition, the basic character of the reduced-value Hong Kong Option Index, which is comprised of the same component securities as the Hong Kong Option Index, and calculated by dividing the Hong Kong Option Index by ten, is essentially identical to the Hong Kong Option Index. Specifically, the Commission believes the Index is broad-based because it reflects a substantial segment of the Hong Kong equities market. First, the Index consists of 30 actively traded stocks traded on the HKSE. Second, the total capitalization of the Index, as of February 28, 1994, was US\$222.214 billion, with the market capitalization of the individual stocks in the Index ranging from a high of US\$23.48 billion to a low of US\$549 million, with a median value of US\$3.89 billion. Third, the Index includes stocks of companies from a broad range of industries and no industry segment comprises more than

25.78% of the Index's total value. Fourth, no single stock comprises more than 14.92% of the Index's total value and the percentage weighting of the five largest issues in the Index accounts for 45.86% of the Index's value. Fifth, the Index component stock listing and maintenance criteria will serve to ensure that the Index maintains its broad representative sample of stocks in the Hong Kong stock market.<sup>24</sup> Accordingly, the Commission believes it is appropriate to classify the Index as broad-based.

### C. Surveillance

In evaluating derivative instruments, the Commission, consistent with the protection of investors, considers the degree to which the derivative instrument is susceptible to manipulation. The ability to obtain information necessary to detect and deter market manipulation and other trading abuses is a critical factor in the Commission's evaluation. It is for this reason that the Commission requires that there be a surveillance sharing agreement in place between an exchange listing or trading derivative product and the exchange(s) trading the stocks underlying the derivative contract, and that the agreement specifically enables officials to surveil trading in the derivative product and its underlying stocks.<sup>25</sup> Such agreements provide a necessary deterrent to manipulation because they facilitate the availability of information needed to investigate fully a potential manipulation if it were to occur. For foreign stock index derivative products, these agreements are especially important to facilitate the collection of necessary regulatory, surveillance and other information from foreign jurisdictions.

To address the foregoing concerns, the Amex has entered into a surveillance

<sup>24</sup> See Securities Exchange Act Release No. 33036, *supra* note 5. The Amex has represented that the companies included in the Index represent at least thirty different broad categories of business covering almost the entire range of business activity conducted in Hong Kong. *Id.*, citing letter from Nathan Most, Senior Vice President, New Products Development, Amex to Richard Zack, Branch Chief, Division of Market Regulation, SEC, dated August 17, 1993, SR-Amex-93-14.

<sup>25</sup> The Commission believes that a surveillance sharing agreement should provide the parties thereto with the ability to obtain information necessary to detect and deter market manipulation and other trading abuses. Consequently, the Commission generally requires that a surveillance sharing agreement require that the parties to the agreement provide each other, upon request, information about market trading activity, clearing activity, and the identity of the ultimate purchasers and sellers of securities. See Securities Exchange Act Release No. 31529 (November 27, 1992), 57 FR 57248.

sharing agreement with the HKSE that provides for the exchange of information relating to the trading of Index options on the Exchange and trading in the component securities of the Index on the HKSE.<sup>26</sup> The agreement, among other things, provides for the sharing of time and sales information, clearing data, and the identity of persons who have bought or sold securities. This agreement obligates the Amex and the HKSE to compile and transmit all relevant market surveillance information and to resolve in "good faith" any disagreements regarding requests for information in response thereto. In addition, the Amex has represented that if information pursuant to the surveillance sharing agreement is not promptly forthcoming from the HKSE, options based on the Index will be removed from trading on the Amex.<sup>27</sup>

The Commission believes that the surveillance sharing agreement entered into between the Amex and HKSE adequately addresses its concerns relating to the ability of the Amex to detect and deter manipulation of the Index through the use of the Index component stocks.<sup>28</sup>

<sup>26</sup> See letter from William Floyd-Jones, Jr., Assistant General Counsel, Legal & Regulatory Policy Division, Amex to Richard Zack, Branch Chief, Division of Market Regulation, SEC, dated August 27, 1993. See also letter from Claire P. McGrath, Managing Director and Special Counsel, Derivative Securities, Amex to Michael Walinskas, Branch Chief, Division of Market Regulation, SEC, dated March 31, 1994.

<sup>27</sup> Should the HKSE deny a request for assistance pursuant to the surveillance sharing agreement and the failure to provide assistance is material to the Amex's self-regulatory effort, the Amex will immediately attempt to implement alternative arrangements for sharing surveillance information with other appropriate self-regulatory and/or governmental authorities. If, despite these efforts, the Amex still is unable to implement such alternative arrangements and determines that it is unable to obtain specific surveillance information pursuant to its agreement with the HKSE which is necessary to carry out its regulatory functions, it will consult with the SEC regarding appropriate regulatory responses. Appropriate regulatory responses in this situation could include the "winding-down" of trading in any options where an information sharing agreement with the HKSE is necessary to ensure the integrity of the market and the SEC advises the Exchange in writing that the public interest and the protection of investors requires the "winding-down" of trading. Such "winding-down" process would involve the cessation of listing any new series, and the delisting of any series where there is no open interest. See letter from William Floyd-Jones, Jr., dated August 27, 1993, *supra* note 26; and letter from Claire P. McGrath, dated March 31, 1994, *supra* note 26.

<sup>28</sup> As an additional surveillance related safeguard to the Index, the Amex requires that the primary trading market for all index component stocks be located in a country with which the Amex has an effective and comprehensive surveillance sharing agreement. See letter from William Floyd-Jones, Jr., dated August 27, 1993, *supra* note 26.

### D. Market Impact

The Commission believes that the listing and trading of Hong Kong Index options, including long-term options based on either the full or a reduced value of the Index, on the Amex will not adversely affect the securities markets in the U.S. or Hong Kong.<sup>29</sup> First, the existing index option surveillance procedures of the Amex will apply to options based on the Index. Second, the Commission notes that the Index is broad-based and diversified and includes highly capitalized securities that are actively traded on the HKSE. Third, the Commission notes that at the present time, index options and futures contracts based on another Hong Kong market index, the Hang Seng Index, are traded on Hong Kong securities and futures exchanges, and that numerous warrants and off-exchange options based on the Hang Seng Index and other Hong Kong related indexes are traded worldwide. Fourth, the position limit of 25,000 contracts on the same side of the market, provided no more than 15,000 of such contracts are in series in the nearest expiration month, will serve to minimize potential manipulation and market impact concerns.<sup>30</sup> Fifth, the risk to investors of contra-party non-performance will be minimized because Index regular and long-term options will be issued and guaranteed by the Options Clearing Corporation just like any other standardized option traded in the United States.

The Commission finds good cause for approving Amendment Nos. 1, 2, and 3 to the proposed rule change prior to the thirtieth day after the date of publication of notice of filing thereof in the *Federal Register*. The purpose and effect of Amendment No. 1 is limited to renaming the Index, clarifying that options based on the Index will begin trading at a certain Index level, and reaffirming that regular Index options will be subject to 2½ point strike intervals if the Index falls below 200.

<sup>29</sup> In addition, the Amex and the Options Price Reporting Authority ("OPRA") have both represented that they have the necessary systems capacity to support those new series of index options that would result from the introduction of Index options and long-term Index options. See letter from Edward Cook, Jr., Director, Information Technology, Amex to Sharon Lawson, Assistant Director, Division of Market Regulation, SEC, dated March 28, 1994; letter from Charles H. Faurot, Managing Director, Market Data Services, Amex to Sharon Lawson, Assistant Director, Division of Market Regulation, SEC, dated March 28, 1994; letter from Joe Corrigan, Executive Director, OPRA to Sharon Lawson, Division of Market Regulation, SEC, dated March 28, 1994.

<sup>30</sup> The Commission notes that the current proposal does not establish a hedge exemption pursuant to Amex Rule 904C, Commentary .01 for Index option participants.



These are non-substantive changes. Amendment No. 2 establishes an Index level of 0.40 times that of the Amex Hong Kong 30 Index. The Commission shares the Amex's concern that the introduction of options at the current higher Amex Hong Kong 30 Index level with a standardized 100 multiplier could result in very high premiums on near-term series, even those slightly out-of-the-money.<sup>31</sup> By introducing a lower Index level for standardized options, Amendment No. 2 addresses this concern, thereby strengthening the Exchange's proposal. Amendment No. 3 reduces from 99 contracts to 50 contracts the maximum number of contracts for market and marketable limit orders in options on the Hong Kong Option Index for which the Amex Auto-Ex system may be used. The Commission believes that reducing the number of contracts subject to Auto-Ex will ensure that only relatively small orders are entitled to automatic execution at the current quote and that larger orders are exposed to the floor for potential price improvement. Further, no comments were received on the original Auto-Ex proposal. Amendment Nos. 1, 2, and 3 help to remove impediments to a free and open securities market and facilitate transactions in securities. Additionally, no comments were received on the proposed rule change set forth in the original notice. Therefore, the Commission believes it is consistent with Sections 6(b)(5) and 19(b)(2) of the Act to approve Amendment Nos. 1, 2, and 3 to the proposal on an accelerated basis.

#### IV. Solicitation of Comments

Interested persons are invited to submit written data, views, and arguments concerning Amendment Nos. 1, 2, and 3. Persons making written submissions should file six copies thereof with the Secretary, Securities and Exchange Commission, 450 Fifth Street, NW., Washington, DC 20549. Copies of the submission, all subsequent amendments, all written statements with respect to the proposed rule change that are filed with the Commission, and all written communications relating to the proposed rule change between the Commission and any person, other than those that may be withheld from the public in accordance with the provisions of 5 U.S.C. 552, will be available for inspection and copying in the Commission's Public Reference Section, 450 Fifth Street, NW., Washington, DC 20549. Copies of such

<sup>31</sup> See Amendment No. 1, *supra* note 3

filing will also be available for inspection and copying at the principal office of the Amex. All submissions should refer to File No. SR-Amex-93-32 and should be submitted by (insert date 21 days from date of publication).

#### V. Conclusion

For the reasons set forth above, the Commission finds that the proposed rule change is consistent with the requirements of the Act and the rules and regulations thereunder applicable to a national securities exchange, and, in particular, the requirements of section 6(b)(5).<sup>32</sup>

It is therefore ordered, pursuant to Section 19(b)(2) of the Act, that the proposed rule change (SR-Amex-93-32), as amended, is approved.

For the Commission, by the Division of Market Regulation, pursuant to delegated authority.<sup>33</sup>

Margaret H. McFarland,  
Deputy Secretary.

[FR Doc. 94-9204 Filed 4-15-94; 8:45 am]

BILLING CODE 8010-01-M

[Release No. 34-33892; File No. SR-NASD-89-16]

#### Self-Regulatory Organizations; National Association of Securities Dealers, Inc.; Order Approving Proposed Rule Change Relating to Specifications and Study Outline for the Registered Options Limited Representative Examination

April 11, 1994.

On March 23, 1989, the National Association of Securities Dealers, Inc. ("NASD") filed with the Securities and Exchange Commission ("Commission"), pursuant to section 19(b)(1) of the Securities Exchange Act of 1934 ("Act")<sup>1</sup> and Rule 19b-4 thereunder,<sup>2</sup> a proposed rule change to establish examination questions, specifications, and a study outline for a Registered Options Limited Representative Examination ("Series 42") to be administered by the NASD.

The proposed rule change was published for comment in the Federal Register on April 12, 1989.<sup>3</sup> The Commission received a total of seven comment letters opposing the proposed rule change. The comment letters were submitted by the American Stock Exchange, Inc. ("Amex"),<sup>4</sup> the New

<sup>1</sup> 15 U.S.C. 78f(b)(5) (1982).

<sup>2</sup> 17 CFR 200.30-3(a)(12) (1993).

<sup>3</sup> 15 U.S.C. 78s(b)(1) (1988).

<sup>4</sup> 17 CFR 240.19b-4 (1993).

<sup>5</sup> See Securities Exchange Act Release No. 26695 (April 4, 1989), 54 FR 14718 (April 12, 1989).

<sup>6</sup> See Letter from Ivers W. Riley, Senior Executive Vice President, Amex, to Jonathan G. Katz,

York Stock Exchange, Inc. ("NYSE"),<sup>5</sup> the Philadelphia Stock Exchange, Inc. ("Phlx"),<sup>6</sup> and the Chicago Board Options Exchange, Inc. ("CBOE").<sup>7</sup> The Commission also received two letters from the NASD in response to those comment letters.<sup>8</sup>

#### I. Background

Since the inception of the Series 7 General Securities Representative Examination program ("Series 7") in 1974,<sup>9</sup> the NASD has continually maintained limited qualification programs for specialized product areas.<sup>10</sup> The NASD represents that the limited qualification programs provide qualification mechanisms that are appropriate to NASD-only member firms that are involved in limited aspects of the securities industry.<sup>11</sup> Until 1988, the NASD maintained two limited representative qualification programs: (1) The Series 6, for investment company products and variable contracts; and (2) the Series 22, for direct participation programs.<sup>12</sup> In 1988, the NASD implemented the Series 62 examination ("Series 62") which qualifies candidates to sell only stocks, bonds, rights, warrants, closed-end investment company shares, real estate investment trusts, and money market funds.<sup>13</sup> The NASD has also acted as the

Secretary, SEC, dated June 16, 1989 ("Amex Letter").

<sup>5</sup> See Letters from James E. Buck, Senior Vice President and Secretary, NYSE, to Diana Luka-Hopson, Branch Chief, Division of Market Regulation ("Division"), SEC, dated August 16, 1993 ("NYSE August 16 Letter"), and December 31, 1993.

<sup>6</sup> See Letter from Nicholas A. Giordano, President, Phlx, to Jonathan G. Katz, Secretary, SEC, dated July 10, 1989 ("Phlx Letter").

<sup>7</sup> See Letters from Charles J. Henry, President and Chief Operating Officer, CBOE, to Jonathan G. Katz, Secretary, SEC, dated June 15, 1989; from Charles J. Henry, President and Chief Operating Officer, CBOE, to Richard Ketchum, Director, Division, SEC, dated September 17, 1990; and from Charles J. Henry, President and Chief Operating Officer, CBOE, to Jonathan Kallman, Associate Director, Division, SEC, dated June 24, 1993 ("CBOE June 24 Letter").

<sup>8</sup> See Letters from Frank J. McAuliffe, Vice President, Qualifications Department, NASD, to Kathy England, Branch Chief, Division, SEC, dated September 27, 1989 ("NASD September 27 Letter"); and from Suzanne Rothwell, Associate General Counsel, NASD, to Thomas Gira, Branch Chief, Division, SEC, dated July 25, 1991 (collectively, "NASD Response Letters").

<sup>9</sup> The Series 7 was jointly developed by the Amex; CBOE; Chicago Stock Exchange, Inc.; NYSE, Phlx, NASD, and Pacific Stock Exchange, Inc. The Series 7 qualifies candidates to sell the full range of securities products, including options.

<sup>10</sup> See NASD September 27 Letter, *supra* note 8.

<sup>11</sup> *Id.*

<sup>12</sup> *Id.*

<sup>13</sup> See Securities Exchange Act Release No. 25719 (May 20, 1988), 53 FR 19076 (May 26, 1988) ("Exchange Act Release No. 25719").

administrative agent for the Series 52 Municipal Securities Representative Examination since it became effective in 1978.<sup>14</sup>

## II. Description of the Proposal

The NASD is now proposing to establish a Series 42 examination which would be used to qualify persons seeking registration as registered options representatives ("RORs") for options overlying equity, debt, foreign currency, and index options. The Exchange represents that the Series 42 examination, when combined with the NASD's other limited product examinations and the Series 52 examination would provide an alternate to the Series 7 for full general securities representative registration.<sup>15</sup>

The examination will be a ninety-minute, 50 question multiple-choice examination, covering all option product areas. A prerequisite to registration as an ROR is registration as a Corporate Securities Limited Representative which requires passing the Series 62, or registration as a General Securities Registered Representative which requires passing the Series 7.<sup>16</sup>

## III. Comments Received on the Proposal

The Commission received comment letters from the Amex, Phlx, NYSE, and CBOE in opposition to the proposal, and response letters from the NASD.<sup>17</sup> The commentators raised objections regarding the utility of the Series 42 and believe that the availability of an alternative qualification scheme to the existing Series 7 could result in investor and regulatory confusion, and could limit investors' access to the options markets.

### A. Utility of the Series 42

The Amex, Phlx, NYSE, and CBOE argue that the usefulness of the Series 42 is limited because broker-dealers who trade options should understand the entire marketplace, especially instruments which underlie options. The Amex believes that the Series 42 will result in broker-dealers having only a narrow understanding of just one type

of product, namely options.<sup>18</sup> Furthermore, the Amex, CBOE, NYSE, and Phlx each believe that the Series 7 is the most effective way of ensuring that the investing public will be served by qualified and informed options representatives because the examination covers virtually every securities product trading on U.S. exchanges and the NASD Automated Quotation System ("NASDAQ").<sup>19</sup>

The Phlx, CBOE, and NYSE believe that except for the Series 62,<sup>20</sup> the NASD's current limited product examinations can be justified because these examinations are intended to accommodate limited purpose broker-dealers and their representatives whose securities activities are limited to specific, discrete product lines, such as investment company products/variable annuities (Series 6), direct participation programs (Series 22), and municipal securities (Series 52) and, therefore, the potential for investor confusion is minimal.<sup>21</sup> In this context, the CBOE notes that unlike the Series 42 and 62, the NASD's other limited product exams do not conflict with the current Series 7 test because such non-exchange traded securities are within the regulatory purview of the over-the-counter market.<sup>22</sup> Further, the Phlx believes that the same economic efficiencies will not be realized from the implementation of the Series 42 because there is not a sufficient number of firms whose business is limited solely to options, or to corporate securities and options, to achieve these efficiencies.<sup>23</sup>

Finally, the CBOE and Phlx argue that the usefulness of the Series 42 is limited because it is likely that no national securities exchange will recognize the examination.<sup>24</sup>

### B. Investor Confusion

The CBOE and NYSE argue that the Series 42 will confuse investors by fragmenting the elements of qualification for the offering of listed

securities options contracts, thus requiring an investor to determine whether or not his stockbroker is qualified to accept his orders in certain products.<sup>25</sup> The CBOE and NYSE also believe that the knowledge and capabilities of a limited product stockbroker may not be as sound as those of a stockbroker who is qualified for all products in the securities markets. For this reason, the CBOE and NYSE recommend that limited product representatives be required to disclose limited qualifications in writing.<sup>26</sup>

Further, the Phlx argues that use of the Series 42 could confuse and mislead public investors by creating specialized representatives within general purpose firms.<sup>27</sup> The Phlx believes that it is possible that a representative qualified under the Series 42 and Series 62 examinations would be unqualified to make recommendations on the range of available investment products suitable to a particular customer, or might seek to dissuade an investor from pursuing certain otherwise appropriate investment products because the representative is not qualified to recommend them.<sup>28</sup> Further, the Phlx believes that because there is no requirement for disclosing the capacities in which a representative is qualified, a customer would not know whether a representative was fully qualified, nor be able to assess any possible "extraneous motives" for a representative's advice.<sup>29</sup>

### C. Regulatory Confusion

The Phlx argues that because the Series 42 covers a product traded almost exclusively on the nations options exchanges, those exchanges should have substantial input in determining the qualifications of representatives who market exchange-traded options.<sup>30</sup> The Phlx states that it is unclear whether the Series 42 is sufficient to qualify a representative to trade certain products, such as non-equity options and whether the examination will be updated to encompass new exchange-traded products.<sup>31</sup>

The Phlx argues that regulatory confusion is also created because it does not appear likely that any exchange will recognize the validity of the Series 42.<sup>32</sup> The Phlx believes that regulatory

<sup>25</sup> See CBOE June 24 Letter, *supra* note 7; and NYSE August 16 Letter, *supra* note 5.

<sup>26</sup> *Id.*

<sup>27</sup> See Phlx Letter, *supra* note 6.

<sup>28</sup> *Id.*

<sup>29</sup> *Id.*

<sup>30</sup> *Id.*

<sup>31</sup> *Id.*

<sup>32</sup> *Id.* See also, CBOE June 24 Letter, *supra* note 7.

<sup>14</sup> See NASD September 27 Letter, *supra* note 8.

<sup>15</sup> That is, the combination of the Series 6, 22, 42, 52, and 62 cover the same range of products as the Series 7. *Id.*

<sup>16</sup> According to the NASD, only registered representatives who passed the Series 7 exam prior to the revisions to the Series 7 in 1986 when only equity options were tested, would opt to take the Series 42 exam. Telephone conversation between David Uthe, Assistant Director, Qualifications, NASD, and Brad Ritter, Attorney, Office of Derivatives and Equity Regulation, Division of Market Regulation, Commission, on April 11, 1994 ("Uthe April 11 Conversation").

<sup>17</sup> See *supra* notes 4 through 8.

<sup>18</sup> See Amex Letter, *supra* note 4.

<sup>19</sup> See Amex Letter, *supra* note 4; CBOE June 24 Letter, *supra* note 7; NYSE August 16 Letter, *supra* note 5; and Phlx Letter, *supra* note 6.

<sup>20</sup> The Phlx, CBOE, and NYSE, believe that the introduction of the Series 62 added confusion to the existing regulatory scheme by creating multiple levels of qualification standards for stockbrokers. See Phlx Letter, *supra* note 6; CBOE June 24 Letter, *supra* note 7; and NYSE August 16 Letter, *supra* note 5. The Commission notes, however, that it did not receive any written comments to the NASD proposal for the Series 62 exam prior to its approval. See Exchange Act Release No. 25719, *supra* note 13.

<sup>21</sup> *Id.*

<sup>22</sup> See CBOE June 24 Letter, *supra* note 7.

<sup>23</sup> See Phlx Letter, *supra* note 6.

<sup>24</sup> See CBOE June 24 Letter, *supra* note 7; and Phlx Letter, *supra* note 6.

concern is raised by Phlx products, such as foreign currency options being marketed to customers by representatives who have not passed the Series 7, which is one of the Exchange's qualification requirements.<sup>33</sup>

Further, the Phlx and CBOE believe that the Series 42 raises concerns for their member firms because the Phlx and CBOE believe that they will have to notify their members that they may incur liability by accepting orders from broker-dealers whose representatives are not Series 7 qualified if the exchanges determine that successful completion of the Series 42 (and Series 62) is inadequate for entry into their markets.<sup>34</sup>

The CBOE believes that regulatory concern is raised by the Series 42 because individuals registered with organizations which are members solely of the NASD may have the ability to recommend listed options trading on an exchange without any assurance that such individuals have the requisite knowledge to do so.<sup>35</sup>

#### D. Limited Access to Options Markets

The CBOE argues that the introduction of the Series 62 represented the first time since options were integrated into the Series 7 exam that individuals have been permitted to qualify to trade the underlying securities without being qualified to trade the derivative product.<sup>36</sup> As a result, the CBOE believes the Series 62 permits individuals to deal with the public concerning products with option-like characteristics (e.g., index warrants) without being qualified to deal in options.<sup>37</sup> While these concerns apply to the Series 62, the CBOE believes the NASD should be required to amend that exam to test for options products rather than introducing the Series 42 as a separate exam.<sup>38</sup>

Similarly, the NYSE and the Phlx argue that the implementation of the Series 42 could result in limiting investor access to the options markets by erecting artificial barriers that could impede or deny access by customers to closely interrelated products because their representatives had not been qualified to trade those products.<sup>39</sup>

#### E. NASD Response to Commentators

The NASD does not agree that the usefulness of the Series 42 is limited.<sup>40</sup> The NASD believes that the Series 42 would raise qualification standards in the options regulatory area and provide a modular alternative route for NASD-only members to achieve a general securities representative status.<sup>41</sup> Additionally, the NASD believes that the Series 42 would improve qualification standards by replacing the Put and Call Questionnaire, which is given "in-house" by the member firms, as a method of testing the qualifications of representatives to trade equity options who have not previously been options qualified.<sup>42</sup> The NASD believes the Series 42 would, accordingly, raise qualification standards by eliminating the use of this questionnaire which is administered by the firms and not by the NASD under test conditions,<sup>43</sup> and provide the NASD with a means of maintaining a permanent record of its registered representatives who have taken the exam and are options qualified.<sup>44</sup>

The NASD further argues that implementation of the Series 42 will not result in investor confusion. The NASD states that there is no evidence that the introduction of the Series 62 has caused investor confusion.<sup>45</sup> The NASD further states that it has not received any inquiries from the investing public which suggest confusion over broker registration regarding the limited registration categories and that the routine examination of their member firms by its surveillance staff shows no particular problems in supervising or controlling marketing staffs with limited registrations, even within general securities firms.<sup>46</sup> The NASD believes that the investing public is more concerned with the fact that a representative is registered and properly

qualified with the NASD or a national securities exchange than with the specific examination taken by the representative.<sup>47</sup>

Finally, the NASD argues that the Series 42 is a substantively adequate examination which will not result in regulatory confusion. The NASD states that the Series 42 was developed by the same industry participants responsible for the development and maintenance of the Series 4 Registered Options Principal ("ROP") Examination. The NASD represents that these individuals are ROPs at general securities firms which are members of all the option exchanges.<sup>48</sup>

The NASD believes that its modular qualification program is fully comparable to the Series 7 and that it provides needed flexibility in meeting appropriate qualification standards for the NASD's diverse membership.<sup>49</sup> The NASD states that candidates electing the NASD modular approach are subject to five tests totaling 450 questions compared to the 250-question Series 7 examination.<sup>50</sup> The NASD further believes that requiring candidates to take the Series 62 prior to taking the Series 42 adequately addresses the derivative nature of the options markets.<sup>51</sup> The NASD, for these reasons, does not believe that implementation of the Series 42 will lessen the basic qualification standards for registered representatives.

#### IV. Discussion

##### A. General

After a careful review of the proposal, the comment letters received, and the NASD's responses to these comment letters, the Commission believes that the proposed rule change is consistent with the requirements of the Act. Specifically, the Commission believes that implementation of the Series 42 examination is a proper exercise of the NASD's responsibility under section 15A(g)(3) of the Act<sup>52</sup> to prescribe standards of training, experience, and competence for persons associated with NASD members.

The Commission notes that Article III, section 33 of the NASD Rules of Fair Practice grants NASD members or persons associated with NASD members the authority to effect transactions in options contracts if those transactions are effected in accordance with the rules, regulations, and procedures

<sup>40</sup> See NASD September 27 Letter, *supra* note 8.

<sup>41</sup> *Id.*

<sup>42</sup> According to the NASD, the Put & Call Questionnaire was developed at the inception of the options markets in 1973 to qualify existing representatives to trade equity options. *Id.* With the development of additional options products, a registered representative who wants to trade a full range of options products and who has only passed the Series 62, would currently have to either (i) complete the Series 7 exam, or (ii) complete the Put & Call Questionnaire as well as the Series 5 (interest rate options) and the Series 15 (foreign currency options). See the April 11 Conversation, *supra* note 16.

<sup>43</sup> See NASD September 27 Letter, *supra* note 8.

<sup>44</sup> Currently, records as to the qualifications of representatives to trade various options products are maintained by the member firms, not by the NASD. See the April 11 Conversation, *supra* note 16.

<sup>45</sup> See NASD September 27 Letter, *supra* note 8.

<sup>46</sup> *Id.*

<sup>47</sup> *Id.*

<sup>48</sup> *Id.*

<sup>49</sup> *Id.*

<sup>50</sup> *Id.*

<sup>51</sup> *Id.*

<sup>52</sup> 15 U.S.C. 78o-3(g)(3) (1988).

<sup>33</sup> See Phlx Letter, *supra* note 6.

<sup>34</sup> See Phlx Letter, *supra* note 6; and CBOE June 24 Letter, *supra* note 7.

<sup>35</sup> See CBOE June 24 Letter, *supra* note 7.

<sup>36</sup> *Id.*

<sup>37</sup> *Id.*

<sup>38</sup> *Id.*

<sup>39</sup> See Phlx Letter, *supra* note 6; and NYSE August 16 Letter, *supra* note 5.

adopted by the NASD's Board of Governors. Further, each person associated with an NASD member whose activities in the investment banking or securities business include the solicitation and/or sale of options contracts is required, by paragraph 1785(2)(d) of Schedule C to the NASD By-Laws, to be certified as a registered options representative and pass an appropriate certification examination.

For these reasons, the NASD has the responsibility, under section 15A(g)(3) of the Act, to prescribe standards of competence for persons associated with NASD member firms who effect transactions in options. The Commission believes that the Series 42, in conjunction with the Series 62, satisfies the NASD's responsibility for prescribing these standards for competence. As described below, the Series 42 has been reviewed by the Commission's Division of Market Regulation and found to be substantively adequate.<sup>53</sup> As also discussed below, the Commission does not agree with the commentator's assertions that the usefulness of the Series 42 is limited or that implementation of the examination will cause regulatory or investor confusion, or will limit access to the options markets.

#### B. Utility of the Series 42

The Series 42 will complete the NASD's modular examination program and provide an alternative route to the Series 7 examination for NASD-only members to achieve a general securities representative status. As such, the Series 42 is within the NASD's discretion for providing adequate qualification mechanisms for persons associated with its members.

The Commission staff has reviewed the Series 42 as proposed and found it to be substantively adequate.<sup>54</sup> Furthermore, the NASD has represented that the Series 42 was developed by the same industry participants responsible for the development and maintenance of the Series 4 ROP examination and that these individuals are ROPs at general securities firms which are members of all the options exchanges. In addition, the NASD has a written agreement with the NYSE pursuant to which selected questions from the Series 7 exam are

<sup>53</sup>The Commission notes, however, that due to the length of time since the submission of this proposal, the SEC's approval of the use of the Series 42 is contingent upon the NASD updating the Series 42, and review by the Commission staff of such changes in the exam, to ensure that it covers all types of options products currently listed and trading on the options exchanges.

<sup>54</sup>*Id.*

reviewed for use in its limited product examinations and questions from NASD's limited product exam question banks are sent to the NYSE for possible inclusion in the Series 7.<sup>55</sup> The Commission believes that the sharing of this information ensures the comparability of the general and limited examination programs and the Commission expects this sharing agreement to continue for the NASD's Series 42 examination. Finally, by requiring successful completion of the Series 62 as a prerequisite for the Series 42, the Commission finds that the NASD has provided an examination structure which will adequately test a candidate's knowledge of the instrument that underlie options.<sup>56</sup> The requirement that the Series 42 be taken in conjunction with the Series 62 adequately addresses the derivative nature of the options markets. Successful completion of the Series 62 ensures that a representative will be knowledgeable about equity securities and their regulation. The knowledge required by the Series 62 exam, combined with the knowledge required by the Series 42, together would be sufficient to ensure that representatives understand the relationship between options and the markets that underlie most options transactions.<sup>57</sup>

The Commission does not believe that the options exchanges' failure to recognize the Series 42 will impair the examination's usefulness to NASD member firms. To the Commission's knowledge, the U.S. securities exchanges do not recognize completion of the Series 62 as being an adequate demonstration of requisite knowledge for purposes of testing the knowledge and competence of their members or the registered representatives of their member firms. Exchange members, however, are permitted, and do, provide clearing and execution services for non-exchange NASD member firms even though some of the registered representatives at these firms have only completed the Series 62.

<sup>55</sup> See NASD September 27, Letter, *supra* note 8.

<sup>56</sup>In response to assertions that certain subjects should be covered by options qualifications examinations, the NASD represents that "interest rate theory" is covered by the Series 62 and the "fundamentals of currency markets" are covered by the Series 42. See NASD September 27 Letter, *supra* note 8. The NASD further represents that all options related areas covered on the Series 7 are tested on the Series 42 exam. See the April 11 Conversation, *supra* note 16.

<sup>57</sup>To the extent that some options overlie assets other than equities or equity indexes (e.g., currency options and interest rate options), the Series 62 and/or the Series 42 will contain questions designed to ensure that representatives understand the characteristics and risks pertaining to non-equity options. *Id.*

Implementation of the Series 42 should not alter this situation even if the exchanges do not recognize the Series 42. Additionally, the Series 42 should provide benefits to the NASD, and by extension, NASD members. NASD-only members are currently tested and qualified to trade options through use of the Put & Call Questionnaire which is administered in-house by member firms. Therefore, even if the exchanges do not recognize the Series 42, the Commission believes that by replacing the in-house Put & Call Questionnaire with an options specific exam administered under established testing procedures, the NASD will be better able to ensure that its members have the requisite knowledge to engage in options transactions. This may also benefit NASD-only members because the Series 42 may be viewed as being a more accurate and therefore more credible reflection of a member's knowledge of options products than the Put & Call Questionnaire.

#### C. Investor Confusion

The Commission does not believe that implementation of the Series 42 will result in investor confusion. Since the introduction of the Series 62, the NASD has not received inquiries which suggest that investors are confused by the limited registration categories.<sup>58</sup> Further, the Commission notes that the routine examination of NASD member firms by the NASD surveillance staff has not uncovered any particular problems in supervising or controlling marketing staffs with limited registrations, even within general securities firms. Accordingly, separate qualification standards for a limited product stockbroker should not confuse investors or result in the knowledge and capabilities of the broker being less sound than those of a stockbroker who has qualified for all products in the securities markets. For these reasons, the Commission believes that there is no factual basis at this time for supporting a requirement that limited product representatives disclose in writing that their registration is limited.

With respect to the possibility of a limited representative dissuading an investor from certain investment products because the representative was not qualified to trade those products, such conduct could violate the representative's fiduciary obligations to his or her customer.<sup>59</sup> Further, the NASD's member firm compliance

<sup>58</sup> See *supra* note 46.

<sup>59</sup>The Series 42 is intended to enable representatives to handle options orders and not restrict them from recommending options.

examinations will check for any abuses which could occur as a result of the NASD's limited registration program. In addition, customers are free to change brokers. If a customer wants to trade a product that the representative is not qualified to handle, and tries to steer the client from, the customer can switch to a different representative. Sufficient client demand for uncovered products should force a representative to broaden his or her qualifications to cover a wider product base.

#### D. Regulatory Confusion

The Commission does not believe that implementation of the Series 42 will result in regulatory confusion. As a preliminary matter, neither the Act nor the NASD Rules require the NASD to develop jointly an options examination with the options exchanges. Although uniformity of tests across self-regulatory organizations ("SROs") would be the most efficient means of ensuring industry competency, an SRO is still capable of developing an exam to cover its particular membership. In this regard, the Act permits the NASD to develop an examination that tests the qualifications of individuals associated with NASD members to trade options.<sup>60</sup>

The Commission also disagrees with the assertion that regulatory concerns are raised by the fact that the options exchanges may not recognize the validity of the Series 42. The Commission believes that implementing the Series 42 is not inconsistent with the options exchanges retaining the Series 7 as their basic qualification requirement for exchange member firms.<sup>61</sup> Use of the Series 42 by the NASD to test the qualifications of its members to trade options does not diminish the options exchanges' authority to determine the qualifications of their own members to trade options. The exchanges can continue to require exchange members to take and pass the Series 7 examination.

The Commission further disagrees with the assertion that individuals registered with NASD member organizations could recommend listed options transactions trading on an exchange without the exchange knowing that such individuals have the requisite knowledge to do so. As discussed above, the Commission

believes that the Series 42 is adequate to test the training, experience, and competence of representatives regarding all types of options transactions.

Finally, the Commission does not believe that there will be increased legal liability on options exchange members because they accepted orders from representatives of NASD-only members who, although not Series 7 qualified, had passed the Series 42 exam. Implementation of the Series 42 will not alter the *status quo* as far as these options exchange members are concerned. These services are currently provided to NASD-only members who have completed only the Series 62 and the Put & Call Questionnaire. The Commission has not been aware of any case in which an exchange member has incurred liability based solely on the fact that the exchange member provided clearing and execution services to a non-Series 7 registered NASD member broker-dealer. The Commission, therefore, does not believe that replacing the Put & Call Questionnaire with the Series 42 will increase the potential for exchange member liability in this regard.

#### E. Limited Access to Options Markets

The Commission disagrees with the assertion that implementation of the Series 42 would result in limiting investor access to the options markets by erecting artificial barriers that could impede or deny access by customers to closely inter-related products because their representatives had not been qualified to trade them. The Commission believes that the Series 42 increases investor access to the options markets because it provides representatives that are only Series 62 qualified with a procedure for becoming qualified to affect transactions in options without having to take the Series 7 exam. Further, the Commission believes that the Series 42 provides better testing for qualified representatives than the current Put & Call Questionnaire administered by firms.

In summary, the Commission believes that the Series 42 exam is an appropriate exercise of the NASD's statutory authority to ensure qualification of its members. The exam itself is sound and tests options knowledge in depth. Despite the objections of the options exchanges, the Commission does not believe there is a regulatory reason to disapprove the Series 42 exam as proposed.

For the reasons set forth above, the Commission finds that the proposed rule changes is consistent with the requirements of the Act and the rules

and regulations thereunder applicable to a registered securities association, and, in particular the requirements of section 15A,<sup>62</sup> and the rules and regulations thereunder.

It is therefore ordered, pursuant to Section 19(b)(2) of the Act,<sup>63</sup> that the proposed rule change (SR-NASD-89-16) is approved contingent upon the NASD's updating of the exam as necessary to reflect the changes that have occurred in the options markets since the time that the Series 42 was originally proposed (e.g., new products) and the Commission's review of the revised examination.

For the Commission, by the Division of Market Regulation, pursuant to delegated authority,<sup>64</sup>

Margaret H. McFarland,  
Deputy Secretary.

[FR Doc. 94-9268 Filed 4-15-94; 8:45 am]  
BILLING CODE 8010-01-M

#### Self-Regulatory Organizations; Applications for Unlisted Trading Privileges; Notice and Opportunity for Hearing; Pacific Stock Exchange, Inc.

April 11, 1994.

The above named national securities exchange has filed applications with the Securities and Exchange Commission ("Commission") pursuant to Section 12(f)(1)(B) of the Securities Exchange Act of 1934 and Rule 12f-1 thereunder for unlisted trading privileges in the following security:

O'Sullivan Corp.  
Common Stock, \$1.00 Par Value (File No. 7-12238)

This security is listed and registered on one or more other national securities exchanges and is reported in the consolidated transaction reporting system.

Interested persons are invited to submit on or before May 2, 1994, written data, views and arguments concerning the above-referenced application. Persons desiring to make written comments should file three copies thereof with the Secretary of the Securities and Exchange Commission, 450 5th Street, NW., Washington, DC 20549. Following this opportunity for hearing, the Commission will approve the application if it finds, based upon all the information available to it, that the extensions of unlisted trading privileges pursuant to such applications are consistent with the maintenance of fair and orderly markets and the protection of investors.

<sup>62</sup> 15 U.S.C. 78o-3 (1988).

<sup>63</sup> 15 U.S.C. 78s(b)(2) (1988).

<sup>64</sup> 17 CFR 200.30-3(a)(12) (1993).

<sup>60</sup> If the NASD determines that it is unable to maintain the quality of the Series 42 so that the examination adequately tests the competency of representatives to effect transactions in options, the NASD should discontinue using the examination.

<sup>61</sup> As the NASD notes, it is likely that most full service firms will continue to opt for the Series 7 examination for their representatives. See NASD September 27 Letter, *supra* note 8.

For the Commission, by the Division of Market Regulations, pursuant to delegated authority.

**Jonathan G. Katz,**  
Secretary.

[FR Doc. 94-9202 Filed 4-15-94; 8:45 am]

BILLING CODE 8010-01-M

**Self-Regulatory Organizations;  
Applications for Unlisted Trading  
Privileges; Notice and Opportunity for  
Hearing; Philadelphia Stock Exchange,  
Incorporated**

April 11, 1994.

The above named national securities exchange has filed applications with the Securities and Exchange Commission ("Commission") pursuant to section 12(f)(1)(B) of the Securities Exchange Act of 1934 and Rule 12f-1 thereunder for unlisted trading privileges in the following securities:

Ford Motor Company  
Common Stock, \$1 Par Value (File No. 7-12236)

Lear Seating Corporation  
Common Stock, \$.01 Par Value (File No. 7-12237)

These securities are listed and registered on one or more other national securities exchanges and are reported in the consolidated transaction reporting system.

Interested persons are invited to submit on or before May 2, 1994, written data, views and arguments concerning the above-referenced application. Persons desiring to make written comments should file three copies thereof with the Secretary of the Securities and Exchange Commission, 450 5th Street, NW., Washington, DC 20549. Following this opportunity for hearing, the Commission will approve the application if it finds, based upon all the information available to it, that the extensions of unlisted trading privileges pursuant to such applications are consistent with the maintenance of fair and orderly markets and the protection of investors.

For the Commission, by the Division of Market Regulation, pursuant to delegated authority.

**Jonathan G. Katz,**  
Secretary.

[FR Doc. 94-9203 Filed 4-15-94; 8:45 am]

BILLING CODE 8010-01-M

**DEPARTMENT OF TRANSPORTATION**

**Federal Aviation Administration**

**[Advisory Circular 25.785-1A]**

**Flight Attendant Seat and Torso  
Restraint System Installations**

**AGENCY:** Federal Aviation Administration, DOT.

**ACTION:** Notice of issuance of advisory circular.

**SUMMARY:** This notice announces the issuance of Advisory Circular (AC) 25.785-1A, Flight Attendant Seat and Torso Restraint System Installations. This AC provides information and guidance regarding an acceptable means, but not the only means, of compliance with the portions of §§ 25.785 and 121.311 of the FAR which deal with flight attendant seats.

**DATES:** Advisory Circular 25.785-1A was issued by the Manager, Transport Airplane Directorate, Aircraft Certification Service, ANM-100, on January 6, 1994.

**HOW TO OBTAIN COPIES:** A copy may be obtained by writing to the U.S. Department of Transportation, Utilization and Storage Section 400 7th St. SW., Washington, DC, 20590, or faxing your request to that office at 202-366-3911.

Issued in Renton, Washington, on March 30, 1994.

**Stewart R. Miller,**  
*Acting Manager, Transport Airplane Directorate, Aircraft Certification Service, ANM-100.*

[FR Doc. 94-9223 Filed 4-15-94; 8:45 am]

BILLING CODE 4910-13-M

**[Advisory Circular 25-9A]**

**Smoke Detection, Penetration, and  
Evacuation Tests and Related Flight  
Manual Emergency Procedures**

**AGENCY:** Federal Aviation Administration, DOT.

**ACTION:** Notice of issuance of advisory circular.

**SUMMARY:** This notice announces the issuance of Advisory Circular (AC) 25-9A, Smoke Detection, Penetration, and Evacuation Tests & Related Flight Manual Emergency Procedures. This AC provides guidance for the conduct of certification tests relating to smoke detection, penetration, and evacuation, and to evaluate related AFM procedures.

**DATES:** Advisory Circular 25-9A was issued by the Manager, Transport Airplane Directorate, Aircraft

Certification Service, ANM-100, on January 6, 1994.

**HOW TO OBTAIN COPIES:** A copy may be obtained by writing to the U.S. Department of Transportation, Utilization and Storage Section, 400 7th St. SW., Washington, DC, 20590, or faxing you request to that office at 202-366-3911.

Issued in Renton, Washington, on March 30, 1994.

**Stewart R. Miller,**  
*Acting Manager, Transport Airplane Directorate, Aircraft Certification Service, ANM-100.*

[FR Doc. 94-9224 Filed 4-15-94; 8:45 am]

BILLING CODE 4910-13-M

**[Advisory Circular 25-18]**

**Transport Category Airplanes Modified  
for Cargo Service**

**AGENCY:** Federal Aviation Administration, DOT.

**ACTION:** Notice of issuance of advisory circular.

**SUMMARY:** This notice announces the issuance of Advisory Circular (AC) 25-18, Transport Category Airplanes Modified for Cargo Service. This AC provides guidance for demonstrating compliance with the FAR pertaining to transport category airplanes converted for use in all-cargo or combination passenger/cargo (combi) service and the relationship of those regulations to the requirements of parts 121 and 135 of the FAR.

**DATES:** Advisory Circular 25-18 was issued by the Manager, Transport Airplane Directorate, Aircraft Certification Service, ANM-100, on January 6, 1994.

**HOW TO OBTAIN COPIES:** A copy may be obtained by writing to the U.S. Department of Transportation, Utilization and Storage Section, 400 7th St. SW., Washington, DC 20590, or faxing your request to that office at 202-366-3911.

Issued in Renton, Washington, on March 30, 1994.

**Stewart R. Miller,**  
*Acting Manager, Transport Airplane Directorate, Aircraft Certification Service, ANM-100.*

[FR Doc. 94-9225 Filed 4-15-94; 8:45 am]

BILLING CODE 4910-13-M

## DEPARTMENT OF THE TREASURY

## Office of the Secretary

## List of Countries Requiring Cooperation With an International Boycott

In order to comply with the mandate of section 999(a)(3) of the Internal Revenue Code of 1986, the Department of the Treasury is publishing a current list of countries which may require participation in, or cooperation with, an international boycott (within the meaning of section 999(b)(3) of the Internal Revenue Code of 1986).

On the basis of the best information currently available to the Department of the Treasury, the following countries may require participation in, or cooperation with, an international boycott (within the meaning of section 999(b)(3) of the Internal Revenue Code of 1986).

Bahrain  
Iraq  
Jordan  
Kuwait  
Lebanon  
Libya  
Oman  
Qatar  
Saudi Arabia  
Syria  
United Arab Emirates  
Yemen, Republic of

Dated: April 11, 1994.

Samuel Y. Sessions,  
Deputy Assistant Secretary for Tax Policy.  
[FR Doc. 94-9201 Filed 4-15-94; 8:45 am]  
BILLING CODE 4810-25-M

## Internal Revenue Service

## Tax on Certain Imported Substances; Withdrawal of Petition

AGENCY: Internal Revenue Service (IRS), Treasury.

ACTION: Notice.

**SUMMARY:** This notice announces the withdrawal, under Notice 89-61, 1989-1 C.B. 717, of a petition requesting that acrylonitrile-butadiene-styrene (ABS) pellets be added to the list of taxable substances in section 4672(a)(3) of the Internal Revenue Code.

**FOR FURTHER INFORMATION CONTACT:** Tyrone J. Montague, Office of Assistant Chief Counsel (Passthroughs and Special Industries), (202) 622-3130 (not a toll-free number).

**SUPPLEMENTARY INFORMATION:** On September 12, 1989, a Notice of Filing was published in the *Federal Register* (54 FR 37757) announcing the acceptance of a petition for ABS

submitted by GE Chemicals. Upon consideration of the written comments received, it has been decided that ABS is a member of the "polystyrene resins and copolymers" group of taxable substances and, as such, is already on the initial list of taxable substances in section 4672(a)(3), effective January 1, 1989. Accordingly, the petitioner is withdrawing that petition.

In addition, on April 14, 1992, a Notice of Receipt of Petitions was published in the *Federal Register* (57 FR 12956) announcing the receipt of a petition for ABS submitted by Dow Chemical Company. That petition by Dow is not accepted because ABS is a substance on the initial list of taxable substances in section 4672(a)(3).

Dale D. Goode,

*Federal Register Liaison Officer, Assistant Chief Counsel (Corporate).*

[FR Doc. 94-9193 Filed 4-15-94; 8:45 am]

BILLING CODE 4830-01-U

## Tax on Certain Imported Substances; Withdrawal of Petitions

AGENCY: Internal Revenue Service (IRS), Treasury.

ACTION: Notice.

**SUMMARY:** This notice announces the withdrawal, under Notice 89-61, 1989-1 C.B. 717, of petitions requesting that certain substances be added to the list of taxable substances in section 4672(a)(3) of the Internal Revenue Code.

**FOR FURTHER INFORMATION CONTACT:** Tyrone J. Montague, Office of Assistant Chief Counsel (Passthroughs and Special Industries), (202) 622-3130 (not a toll-free number).

**SUPPLEMENTARY INFORMATION:** On April 14, 1992, a Notice of Receipt of Petitions was published in the *Federal Register* (57 FR 12956) announcing the receipt of a petition for alpha methyl styrene polymer submitted by Amoco Corporation. The petitioner has withdrawn that petition.

On May 10, 1992, a Notice of Receipt of Petitions was published in the *Federal Register* (58 FR 27617) announcing the receipt of a petition for polymeric MDI (diphenylmethane diisocyanate) submitted by Miles Inc. The petitioner has withdrawn that petition.

Dale D. Goode,

*Federal Register Liaison Officer, Assistant Chief Counsel (Corporate).*

[FR Doc. 94-9194 Filed 4-15-94; 8:45 am]

BILLING CODE 4830-01-U

## Tax on Certain Imported Substances; Filing of Petition

AGENCY: Internal Revenue Service (IRS), Treasury.

ACTION: Notice.

**SUMMARY:** This notice announces the acceptance, under Notice 89-61, 1989-1 C.B. 717, of a petition requesting that di-2 ethyl hexyl phthalate be added to the list of taxable substances in section 4672(a)(3) of the Internal Revenue Code. Publication of this notice is in compliance with Notice 89-61. This is not a determination that the list of taxable substances should be modified.

**DATES:** Written comments and requests for a public hearing relating to this petition must be received by June 17, 1994. Any modification of the list of taxable substances based upon this petition would be effective October 1, 1993.

**ADDRESSES:** Send comments and requests for a public hearing to: CC:DOM:CORP:T:R (Petition), room 5228, Internal Revenue Service, POB 7604, Ben Franklin Station, Washington, DC 20044.

**FOR FURTHER INFORMATION CONTACT:** Tyrone J. Montague, Office of Assistant Chief Counsel (Passthroughs and Special Industries), (202) 622-3130 (not a toll-free number).

**SUPPLEMENTARY INFORMATION:** The petition was received on November 10, 1992. The petitioner is Aristech Chemical Corporation, a manufacturer and exporter of this substance. The following is a summary of the information contained in the petition. The complete petition is available in the Internal Revenue Service Freedom of Information Reading Room.

HTS number: 2917.32.00.00  
CAS number: 117-81-7

This substance is derived from the taxable chemicals xylene and propylene. Di-2 ethyl hexyl phthalate is a liquid produced predominantly by acid catalyzed esterification of phthalic anhydride (derived from o-xylene) and 2-ethyl hexanol (derived from propylene).

The stoichiometric material consumption formula for this substance is:  $C_8H_{10}$  (xylene) +  $4 C_3H_6$  (propylene) +  $3 O_2$  (oxygen) +  $4 CO$  (carbon monoxide) +  $8 H_2$  (hydrogen)  $\rightarrow C_{24}H_{36}O_4$  (di-2 ethyl hexyl phthalate) +  $6 H_2O$  (water).

According to the petition, taxable chemicals constitute 55 percent by weight of the materials used to produce this substance. The rate of tax for this substance would be \$3.42 per ton. This is based upon a conversion factor for

xylene of 0.272 and a conversion factor for propylene of 0.431.

Dale D. Goode,

Federal Register Liaison Officer, Assistant Chief Counsel (Corporate).

[FR Doc. 94-9195 Filed 4-15-94; 8:45 am]

BILLING CODE 4830-01-U

### Tax on Certain Imported Substances; Filing of Petition

**AGENCY:** Internal Revenue Service (IRS), Treasury.

**ACTION:** Notice.

**SUMMARY:** This notice announces the acceptance, under Notice 89-61, 1989-1 C.B. 717, of a petition requesting that polycarbonate be added to the list of taxable substances in section 4672(a)(3) of the Internal Revenue Code.

Publication of this notice is in compliance with Notice 89-61. This is not a determination that the list of taxable substances should be modified.

**DATES:** Written comments and requests for a public hearing relating to this petition must be received by June 17, 1994. Any modification of the list of taxable substances based upon this petition would be effective July 1, 1993.

**ADDRESSES:** Send comments and requests for a public hearing to: CC:DOM:CORP:T:R (Petition), room 5228, Internal Revenue Service, POB 7604, Ben Franklin Station, Washington, DC 20044.

#### FOR FURTHER INFORMATION CONTACT:

Tyrone J. Montague, Office of Assistant Chief Counsel (Passthroughs and Special Industries), (202) 622-3130 (not a toll-free number).

**SUPPLEMENTARY INFORMATION:** The petition was received on August 4, 1992. The petitioner is Miles, Inc., a manufacturer and exporter of this substance. The following is a summary of the information contained in the petition. The complete petition is available in the Internal Revenue Service Freedom of Information Reading Room.

HTS number: 3907.40.00.00

CAS number: 127133-67-9

This substance is derived from the taxable chemicals methane, chlorine, benzene, propylene, and sodium hydroxide. Polycarbonate is a solid produced predominantly by the interfacial polycondensation reaction of the sodium salt solution of bisphenol-A in an aqueous phase and phosgene in an organic phase.

The stoichiometric material consumption formula for this substance is:  $\text{CH}_4$  (methane) +  $\text{Cl}_2$  (chlorine) + 2  $\text{C}_6\text{H}_6$  (benzene) +  $\text{C}_3\text{H}_6$  (propylene) + 2

$\text{NaOH}$  (sodium hydroxide) + 3  $\text{O}_2$  (oxygen)  $\longrightarrow$   
 $\text{O}(\text{C}_6\text{H}_4)\text{C}(\text{CH}_3)_2(\text{C}_6\text{H}_4)\text{OCO}$   
 (polycarbonate) + 5  $\text{H}_2\text{O}$  (water) + 2  $\text{NaCl}$  (sodium chloride).

According to the petition, taxable chemicals constitute 79.1 percent by weight of the materials used to produce this substance. The rate of tax for this substance would be \$4.91 per ton. This is based upon a conversion factor for methane of 0.083, a conversion factor for chlorine of 0.276, a conversion factor for benzene of 0.614, a conversion factor for propylene of 0.165, and a conversion factor for sodium hydroxide of 0.315.

Dale D. Goode,

Federal Register Liaison Officer, Assistant Chief Counsel (Corporate).

[FR Doc. 94-9197 Filed 4-15-94; 8:45 am]

BILLING CODE 4830-01-U

### Tax on Certain Imported Substances; Filing of Petitions

**AGENCY:** Internal Revenue Service (IRS), Treasury.

**ACTION:** Notice.

**SUMMARY:** This notice announces the acceptance, under Notice 89-61, 1989-1 C.B. 717, of petitions requesting that sodium nitriolotriacetate monohydrate, diphenyl oxide, and tetrachlorophthalic anhydride be added to the list of taxable substances in section 4672(a)(3) of the Internal Revenue Code. Publication of this notice is in compliance with Notice 89-61. This is not a determination that the list of taxable substances should be modified.

**DATES:** Written comments and requests for a public hearing relating to these petitions must be received by June 17, 1994. Any modification of the list of taxable substances based upon these petitions would be effective April 1, 1993.

**ADDRESSES:** Send comments and requests for a public hearing to: CC:DOM:CORP:T:R (Petition), room 5228, Internal Revenue Service, POB 7604, Ben Franklin Station, Washington, DC 20044.

#### FOR FURTHER INFORMATION CONTACT:

Tyrone J. Montague, Office of Assistant Chief Counsel (Passthroughs and Special Industries), (202) 622-3130 (not a toll-free number).

**SUPPLEMENTARY INFORMATION:** The petitions were received on April 30, 1992 (sodium nitriolotriacetate monohydrate), June 29, 1992 (diphenyl oxide), and July 2, 1992 (tetrachlorophthalic anhydride). The petitioner is Monsanto Company, a manufacturer and exporter of these

substances. The following is a summary of the information contained in the petitions. The complete petitions are available in the Internal Revenue Service Freedom of Information Reading Room.

**Sodium nitriolotriacetate monohydrate**

HTS number: 2922.49.60.00

CAS number: 18662-53-8

This substance is derived from the taxable chemicals methane, sodium hydroxide, propylene, and ammonia. Sodium nitriolotriacetate monohydrate is a solid produced predominantly by the reaction of formaldehyde with hydrogen cyanide in the presence of a catalyst, which is then further reacted with sodium hydroxide to produce sodium nitriolotriacetate monohydrate.

The stoichiometric material consumption formula for this substance is: 3  $\text{CH}_4$  (methane) + 3  $\text{NaOH}$  (sodium hydroxide) +  $\text{C}_3\text{H}_6$  (propylene) +  $\text{NH}_3$  (ammonia) + 4.5  $\text{O}_2$  (oxygen)  $\longrightarrow$   $\text{N}(\text{CH}_2\text{COONa})_3\text{H}_2\text{O}$  (sodium nitriolotriacetate monohydrate) + 5  $\text{H}_2\text{O}$  (water) + 3  $\text{H}_2$  (hydrogen).

According to the petition, taxable chemicals constitute 61.1 percent by weight of the materials used to produce this substance. The rate of tax for this substance would be \$2.45 per ton. This is based upon a conversion factor for methane of 0.24, a conversion factor for sodium hydroxide of 0.52, a conversion factor for propylene of 0.25, and a conversion factor for ammonia of 0.10.

#### Diphenyl oxide

HTS number: 2909.30.00.00

CAS number: 101-84-8

This substance is derived from the taxable chemicals benzene and propylene. Diphenyl oxide is a solid produced predominantly by the catalytic condensation of phenol.

The stoichiometric material consumption formula for this substance is: 2  $\text{C}_6\text{H}_6$  (benzene) + 2  $\text{C}_3\text{H}_6$  (propylene) + 2  $\text{O}_2$  (oxygen)  $\longrightarrow$   $\text{C}_{12}\text{H}_{10}\text{O}$  (diphenyl oxide) + 2  $\text{C}_3\text{H}_6\text{O}$  (acetone) +  $\text{H}_2\text{O}$  (water).

According to the petition, taxable chemicals constitute 78.9 percent by weight of the materials used to produce this substance. The rate of tax for this substance would be \$8.13 per ton. This is based upon a conversion factor for benzene of 1.05 and a conversion factor for propylene of 0.62.

#### Tetrachlorophthalic anhydride

HTS number: 2916.19.00.00

CAS number: 117-08-8

This substance is derived from the taxable chemicals chlorine and xylene. Tetrachlorophthalic anhydride is a solid



produced predominantly by the high temperature reaction of phthalic anhydride with chlorine. Phthalic anhydride is produced by the reaction of o-xylene with air in the presence of a catalyst.

The stoichiometric material consumption formula for this substance is:  $4 \text{ Cl}_2$  (chlorine) +  $\text{C}_8\text{H}_{10}$  (xylene) +  $3 \text{ O}_2$  (oxygen)  $\longrightarrow$   $\text{C}_8\text{Cl}_4\text{O}_3$  (tetrachlorophthalic anhydride) +  $3 \text{ H}_2\text{O}$  (water) +  $4 \text{ HCl}$  (hydrogen chloride).

According to the petition, taxable chemicals constitute 80 percent by weight of the materials used to produce this substance. The rate of tax for this substance would be \$5.87 per ton. This is based upon a conversion factor for chlorine of 1.22 and a conversion factor for xylene of 0.53.

**Dale D. Goode,**

*Federal Register Liaison Officer, Assistant Chief Counsel (Corporate).*

[FR Doc. 94-9196 Filed 4-15-94; 8:45 am]

BILLING CODE 4830-01-U

#### DEPARTMENT OF VETERANS AFFAIRS

##### A Managed Care Clinical Research and Education Center at the VAMC Minneapolis, MN

**AGENCY:** Department of Veterans Affairs.

**ACTION:** Notice of designation.

**SUMMARY:** The Secretary of the Department of Veterans Affairs is designating the Minneapolis, MN Veterans Affairs Medical Center for an Enhanced-Use development. The Department intends to enter into a long-term lease of real property with the health care developer whose proposal will provide the best quality managed care facility at the greatest economic advantage for the Department and veterans. The developer will be responsible for all aspects of construction, ownership, and maintenance of the Managed Care Clinical Research and Education Center. The Center will be operated by the Department for the purpose of improving managed care services for area veterans. The developer will be required, over the term of the lease, to enter into collaborative teaching and/or research initiatives and sharing

agreements for specialized medical services with the Department. In addition, the developer will be allowed to construct and operate an outpatient clinic on the site for its members.

**FOR FURTHER INFORMATION CONTACT:**

Brian McDaniel, Office of Asset and Enterprise Development (089), Veterans Health Administration, Department of Veterans Affairs, 810 Vermont Avenue NW., Washington, DC 20420, (202) 233-3307.

**SUPPLEMENTARY INFORMATION:** 38 U.S.C. Sec 8161 *et seq.* specifically provides that the Secretary may enter into an Enhanced-Use lease, if the Secretary determines that at least part of the use of the property under the lease will be to provide appropriate space for an activity contributing to the mission of the Department; the lease will not be inconsistent with and will not adversely affect the mission of the Department; and the lease will enhance the property. This project meets these requirements.

Approved: April 5, 1994.

**Jesse Brown,**

*Secretary Veterans Affairs.*

[FR Doc. 94-9186 Filed 4-15-94; 8:45 am]

BILLING CODE 8320-01-M

# Sunshine Act Meetings

Federal Register

Vol. 59, No. 74

Monday, April 18, 1994

This section of the FEDERAL REGISTER contains notices of meetings published under the "Government in the Sunshine Act" (Pub. L. 94-409) 5 U.S.C. 552b(e)(3).

## FEDERAL ENERGY REGULATORY COMMISSION

"FEDERAL REGISTER" CITATION OF PREVIOUS ANNOUNCEMENT: April 6, 1994, 59 FR 17152.

PREVIOUSLY ANNOUNCED TIME AND DATE OF MEETING: April 13, 1994, 10:00 a.m.

CHANGE IN THE MEETING: The following Docket Numbers have been added to Items CAG-2 and CAG-49 on the Agenda scheduled for April 13, 1994:

### Item No., Docket No., and Company

CAG-2—RP91-90-000, TM91-12-21-000, TM92-2-21-000, TM92-3-21-000, TM92-9-21-000, TM92-10-21-000, TM92-11-21-000, and TM93-5-21-000, Columbia Gas Transmission Corporation  
CAG-49—CP93-501-000, Tennessee Gas Pipeline Company

Lois D. Cashell,

Secretary.

[FR Doc. 94-9361 Filed 4-14-94; 11:15 am]

BILLING CODE 6717-01-M

## FEDERAL COMMUNICATIONS COMMISSION FCC To Hold Open Commission Meeting Wednesday, April 20, 1994

The Federal Communications Commission will hold an Open Meeting on the subjects listed below on Wednesday, April 20, 1994, which is scheduled to commence at 9:30 a.m., in Room 856, at 1919 M Street, N.W., Washington, D.C.

### Item No., Bureau, and Subject

- 1—Office of International Communications; Office of Engineering and Technology—Title: Preparation for International Telecommunication Union World Radiocommunication Conferences. Summary: The Commission will consider adoption of a Notice of Inquiry soliciting information and comment from the public to assist it in developing U.S. proposals for the 1995 and future World Radiocommunication Conferences.
- 2—Office of Engineering and Technology—Title: Allocation of Spectrum below 5 GHz

Transferred from Federal Government Use. Summary: The Commission will consider adoption of a Notice of Inquiry soliciting comment on spectrum proposed to be transferred from Federal Government to private sector use.

- 3—Office of Plans and Policy—Title: Implementation of Section 309(j) of the Communications Act—Competitive Bidding (PP Docket No. 93-253). Summary: The Commission will consider adoption of a Third Report and Order to prescribe regulations concerning competitive bidding procedures for licenses to be awarded for Personal Communications Services in the 900 MHz band ("narrowband PCS").
- 4—Private Radio Office of Plans and Policy—Title: Implementation of Section 309(f) of the Communications Act—Competitive Bidding (PP Docket No. 93-253). Summary: The Commission will consider adoption of a Fourth Report and Order to prescribe regulations concerning competitive bidding procedures for licenses to be awarded for Interactive Video and Data Service (IVDS).
- 5—Private Radio Common Carrier—Title: Implementation of Sections 3(n) and 332 of the Communications Act—Regulatory Treatment of Mobile Services (GN Docket No. 93-252). Summary: The Commission will consider adoption of a Further Notice of Proposed Rulemaking concerning amendments to the Commission's technical, operational, and licensing rules for Commercial Mobile Radio Services.
- 6—Private Radio Common Carrier—Title: Further Forbearance from Title II Regulation for Certain Types of Commercial Mobile Radio Service Providers. Summary: The Commission will consider adoption of a Notice of Proposed Rulemaking concerning whether and how to forbear further from applying provisions of Title II of the Communications Act that pertain to commercial mobile radio services.
- 7—Common Carrier—Title: Revision of Part 22 of the Commission's Rules Governing the Public Mobile Services (CC Docket No. 92-115). Summary: The Commission will consider adoption of a Further Notice of Proposed Rulemaking concerning amendments to Part 22 of the Commission's rules.
- 8—Mass Media—Title: Implementation of Commission's Equal Employment Opportunity Rule. Summary: The Commission will consider adoption of a

Notice of Inquiry which seeks comment on the Commission's rules, procedures, policies, standards and guidelines in promoting equality of employment and promotion opportunity in cable, broadcast and other industries and on proposals for changes in these areas.

This meeting may be continued the following work day to allow the Commission to complete appropriate action.

Additional information concerning this meeting may be obtained from Steve Svab, Office of Public Affairs, telephone number (202) 632-5050.

Dated: April 13, 1994.

Federal Communications Commission.

William F. Caton,

Acting Secretary.

[FR Doc. 94-9357 Filed 4-14-94 11:00 am]

BILLING CODE 6712-01-M

## FEDERAL MINE SAFETY AND HEALTH REVIEW COMMISSION

TIME AND DATE: 11:00 a.m., Tuesday, April 12, 1994.

PLACE: 6th Floor, 1730 K Street, N.W., Washington, DC.

STATUS: Closed [Pursuant to 5 U.S.C. § 552b(c)(10)].

MATTERS TO BE CONSIDERED: The Commission will consider and act upon the following:

1. *In re: Southmountain Coal Co.*, No. 94-1388, 4th Cir. Petition for Writ of Mandamus (Issues include consideration of court order.)

It was determined by a unanimous vote of the Commission that a meeting be held on this item in closed session and that no earlier announcement of the meeting was possible.

CONTACT PERSON FOR MORE INFO: Jean Ellen (202) 653-5629/(202) 708-9300 for TDD Relay/1-800-877-8339 for toll free was possible.

Dated: April 12, 1994.

Jean H. Ellen,  
Chief Docket Clerk.

[FR Doc. 94-9356 Filed 4-14-94; 11:02 am]

BILLING CODE 6735-01-M

# Corrections

Federal Register

Vol. 59, No. 74

Monday, April 18, 1994

This section of the FEDERAL REGISTER contains editorial corrections of previously published Presidential, Rule, Proposed Rule, and Notice documents. These corrections are prepared by the Office of the Federal Register. Agency prepared corrections are issued as signed documents and appear in the appropriate document categories elsewhere in the issue.

## FEDERAL MARITIME COMMISSION

46 CFR Part 540

[Docket No. 94-06]

### Financial Responsibility Requirements for Nonperformance of Transportation

#### Correction

In proposed rule document 94-7647 beginning on page 15149 in the issue of Thursday, March 31, 1994, make the following correction:

#### § 540.5 [Corrected]

On page 15150, in the third column, in the table, in the second column, in the first entry, "10% of UPR." should read "110% of UPR."

BILLING CODE 1505-01-D

## DEPARTMENT OF LABOR

### Occupational Safety and Health Administration

29 CFR Parts 1910, 1915, 1926, and 1928

[Docket No. H-122]

RIN 1218-AB37

### Indoor Air Quality

#### Correction

In proposed rule document 94-7619 beginning on page 15968 in the issue of Tuesday, April 5, 1994, on page 15968, in the second column, in the DATES

paragraph, in the seventh line, "July 5, 1994" should read "June 29, 1994."

BILLING CODE 1505-01-D

## SECURITIES AND EXCHANGE COMMISSION

[Release No.34-33843; File No. SR-CBOE-94-04]

### Self-Regulatory Organizations; Filing of Proposed Rule Change by the Chicago Board Options Exchange, Inc., Relating to Listing Criteria for Certain Hybrid Securities

March 31, 1994.

#### Correction

In notice document 94-8281 beginning on page 16666 in the issue of Thursday, April 7, 1994, on page 16666, the date set forth above was inadvertently omitted.

BILLING CODE 1505-01-D

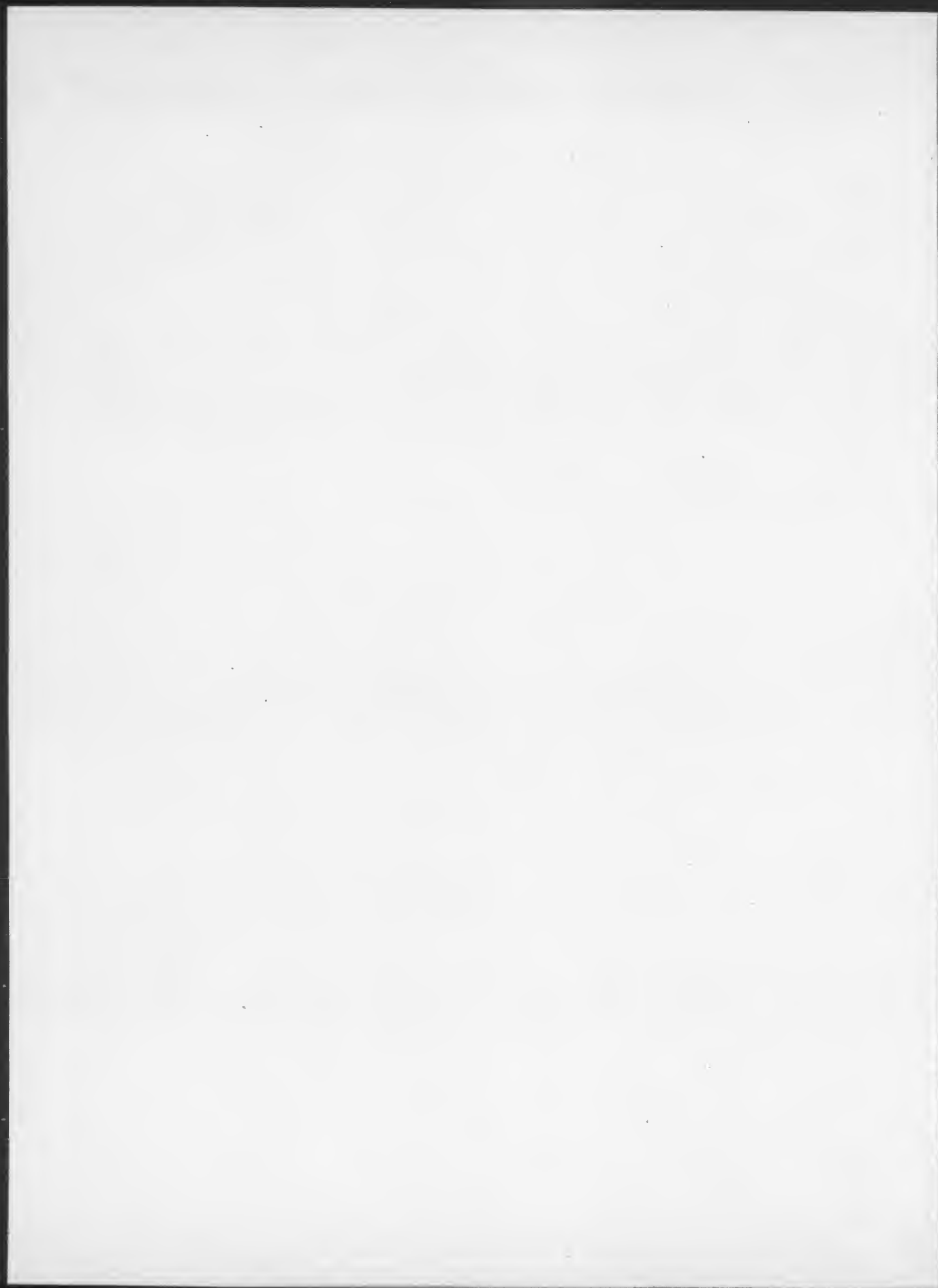

---

Monday  
April 18, 1994

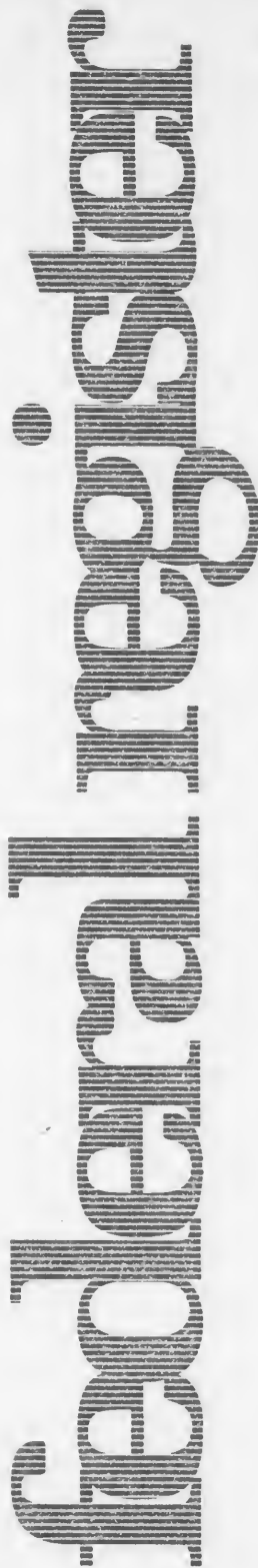

---

Part II

**Postal Service**

---

39 CFR Parts 1 Through 8, et al.  
Amendment to Bylaws of the Board of  
Governors; Final Rule

**POSTAL SERVICE****39 CFR Parts 1 Through 8, 11, and 221****Amendment to Bylaws of the Board of Governors**

AGENCY: Postal Service.

ACTION: Final rule.

**SUMMARY:** On July 13, 1993, the Board of Governors of the United States Postal Service adopted a revision to its bylaws. This final rule incorporates those changes, which update and to some extent streamline the Board's bylaws.

**EFFECTIVE DATE:** July 13, 1993.**FOR FURTHER INFORMATION CONTACT:** Stanley F. Mirés, (202) 268-2958.

**SUPPLEMENTARY INFORMATION:** The bylaws of the Board of Governors of the United States Postal Service, 39 CFR parts 1 through 10, were initially adopted after the passage of the Postal Reorganization Act in 1971, and have been amended several times. On July 13, 1993, the Board of Governors adopted a revision of these bylaws. Parts 1 through 8 of the bylaws were changed, and a new part 11 was added. (Parts 9 and 10 of the bylaws were not changed and are not republished here.) In addition, 39 CFR part 221 was amended. An explanation follows.

**Part 1—Postal Policy (Article I)**

Several changes were made to part 1 for conciseness. The former language of § 1.1 (a general description of the Postal Service) is replaced by similar language taken from former § 2.1, Establishment of the U.S. Postal Service. Language formerly contained in § 1.2, The Board of Governors, also is transferred to the new § 1.1.

Former § 1.3, Delegation of authority, is renumbered as § 1.2. Finally, former § 1.4, Open meetings, is moved to part 7, Public Observation, and appears as paragraph 7.2(a).

**Part 2—General and Technical Provisions (Article II)**

Section 2.1 now describes the physical location and function of the Office of the Board of Governors, and is derived from former § 3.9.

The language of § 2.2, Agent for receipt of process, is amended to reflect that the General Counsel is also the agent for receipt of process for each individual member of the Board when the member is acting in his or her official capacity. The language of paragraph 2.4(b), which describes the Postal Service emblem, registered by the U.S. Patent Office, is moved to § 221.9 of part 221, General Principles of Organization.

**Part 3—Board of Governors (Article III)**

Former §§ 3.1 and 3.2 are combined into a new § 3.1, Responsibilities of Board, and language duplicating 39 U.S.C. 202 is deleted. Duplicative language is likewise deleted from renumbered § 3.2, Compensation of Board.

For ease of reference, § 3.3 is amended to contain only matters reserved for decision by the full Board. New § 3.4, by contrast, contains matters reserved for decision by the Governors only.

Other changes in part 3 were made. New paragraph 3.3(c)(2) is added to provide for Board approval of the Postal Service operating budget. Language is added to paragraph 3.3(e) to provide that projects above an amount specified by annual Board resolution must be brought to the Board for approval. New language in paragraph 3.3(j) (approval of borrowing authority) clarifies what is intended by the term "short-term borrowings," and it eliminates the phrase "purchase money obligations," which is no longer used in the finance industry. Paragraph 3.3(k) (approval of terms and conditions of obligations issued by the Postal Service) also is updated to parallel the new language in paragraph 3.3(j).

Paragraph 3.3(m) (determination of number of officers) is simplified to remove the titles of specific officer positions that could change. Likewise, the names of specific positions were removed from paragraph 3.3(n) (compensation of officers at Level II of the Postal Career Executive Service).

Section 3.6 is revised to specify the types of key reports currently provided to the Board. Paragraph 3.7(d) is added to enhance program information provided to the Board. Section 3.8 is changed to provide for furnishing the Board with information concerning proposals for exclusive licenses to use Postal Service intellectual properties, other than patents and technical data rights, or proposals for joint ventures involving the use of such property. Section 3.9 is deleted; its language describing the Office of the Board of Governors was transferred to § 2.1.

**Part 4—Officers (Article IV)**

Section 4.3, Postmaster General, is simplified to delete language duplicating statutory language found at 39 U.S.C. 202(c) and 203. Similarly, § 4.4, Deputy Postmaster General, is simplified by removing language duplicating 39 U.S.C. 202(d) and 203. Section 4.5 is shortened by deleting outdated titles for officers. Section 4.7 is changed to describe more closely the current duties of the Secretary of the

Board, and to clarify that the Secretary is appointed by the Governors.

**Part 5—Committees (Article V)**

Section 5.3 is deleted as duplicative of the statutory language on compensation of the Board in 39 U.S.C. 202(a).

**Part 6—Meetings (Article VI)**

Section 6.1 is amended to reflect that the Board meets normally on the first Monday and Tuesday of each month. New language provides that the time or place of a regular or annual meeting may be varied by a unanimous vote.

Section 6.2 is changed to allow the Chairman to call special meetings with more than 30 days' notice. Section 6.5 is amended to provide that there is no need to require the preservation of the Board's original minutes, as opposed to copies of those minutes. Paragraph 6.6(c) is added to require a favorable vote of an absolute majority of the Governors in office to appoint or remove the Secretary or Assistant Secretary, and to set the compensation of the Secretary or Assistant Secretary.

**Part 7—Public Observation (Article VII)**

Former § 1.4, Open meetings, now appears as paragraph 7.2(a). Other paragraphs of § 7.2 are renumbered accordingly. Paragraph 7.2(c) is amended to require the approval of a majority of the Board for a person to participate in, film, televise, or broadcast any portion of any meeting of the Board. Paragraph 7.3(f) is altered to extend its privacy protection to all individuals, not just those who are under consideration for postal employment.

**Part 8—(Reserved)**

Part 8, Reports and Records [Article VIII], is deleted as duplicative. Section 3.3 describes reports requiring approval of the Board (see 39 CFR 3.3(c)(1) and 3.3(r-u)).

Part 9—Policy on Communications With Governors of the Postal Service During Pendency of Rate and Classification Proceedings (Article IX)

Part 9 is unchanged.

Part 10—Code of Ethical Conduct for Postal Service Governors (Article X)

Part 10 is unchanged.

Part 11—Advisory Boards (Article XI)

Part 11 is added to authorize the establishment of advisory boards for the Board of Governors. This part also states that the Board of Governors may appoint persons to serve on such advisory boards or may delegate this authority to the Postmaster General.

**Part 221—General Principles of Organization**

Language pertaining to the Postal Service emblem, formerly found at paragraph 2.4(b), now appears as § 221.9.

**List of Subjects in 39 CFR Parts 1 Through 8, 11, and 221**

Administrative practice and procedure, Organization and functions (Government agencies), Postal Service, Reporting requirements, Sunshine Act.

In consideration of the foregoing, the Postal Service amends subchapter A of title 39, Code of Federal Regulations, by revising parts 1 through 8 and by adding part 11, and also amends subchapter D of title 39, Code of Federal Regulations, by adding section 221.9.

1. Parts 1 through 7 are revised and part 8 is removed and reserved, as follows:

**PART 1—POSTAL POLICY (ARTICLE I)**

## Sec.

- 1.1 Establishment of the U.S. Postal Service.  
1.2 Delegation of authority.

**Authority:** 39 U.S.C. 101, 202, 205, 401(2), 402, 403, 3621, as enacted by Public Law 91-375.

**§ 1.1 Establishment of the U.S. Postal Service.**

The U.S. Postal Service is established under the provisions of the Postal Reorganization Act (the Reorganization Act) of August 12, 1970, Public Law 91-375, 84 Stat. 719, as an independent establishment of the executive branch of the Government of the United States, under the direction of a Board of Governors, with the Postmaster General as its chief executive officer. The Board of Governors of the Postal Service (the Board) directs the exercise of its powers through management that is expected to be honest, efficient, economical, and mindful of the competitive business environment in which the Postal Service operates. The Board consists of nine Governors appointed by the President, by and with the advice and consent of the Senate, to represent the

public interest generally, together with the Postmaster General and Deputy Postmaster General.

**§ 1.2 Delegation of authority.**

Except for powers, duties, or obligations specifically vested in the Governors by law, the Board may delegate its authority to the Postmaster General under such terms, conditions, and limitations, including the power of redelegation, as it finds desirable. The bylaws of the Board are the framework of the system through which the Board monitors the exercise of the authority it has delegated, measures progress toward the goals it has set, and shapes the policies to guide the future development of the Postal Service. Delegations of authority do not relieve the Board of full responsibility for carrying out its duties and functions, and are revocable by the Governors in their exclusive judgment.

**PART 2—GENERAL AND TECHNICAL PROVISIONS (ARTICLE II)**

## Sec.

- 2.1 Office of the Board of Governors.  
2.2 Agent for receipt of process.  
2.3 Offices.  
2.4 Seal.  
2.5 Authority.  
2.6 Severability, amendment, repeal, and waiver of bylaws.

**Authority:** 39 U.S.C. 202, 203, 205(c), 207, 401(2), as enacted by Pub. L. 91-375, and 5 U.S.C. 552b(f), (g), as enacted by Pub. L. 94-409.

**§ 2.1 Office of the Board of Governors.**

There shall be located in Washington, DC an Office of the Board of Governors of the United States Postal Service. It shall be the function of this Office to provide staff support for the Board, as directed by the Chairman of the Board, to enable the Board to carry out effectively its duties under the Reorganization Act.

**§ 2.2 Agent for receipt of process.**

The General Counsel of the Postal Service shall act as agent for the receipt of legal process against the Postal Service, and as agent for the receipt of

legal process against the Board of Governors or a member of the Board, in his or her official capacity, and all other officers and employees of the Postal Service to the extent that the process arises out of the official functions of those officers and employees. The General Counsel shall also issue public certifications concerning closed meetings of the Board as appropriate under 5 U.S.C. 552b(f).

**§ 2.3 Offices.**

The principal office of the Postal Service is located in Washington, DC, with such regional and other offices and places of business as the Postmaster General establishes from time to time, or the business of the Postal Service requires.

**§ 2.4 Seal.**

(a) The Seal of the Postal Service is filed by the Board in the Office of the Secretary of State, and is required by 39 U.S.C. 207 to be judicially noticed. The Seal shall be in the custody of the General Counsel, who shall affix it to all commissions of officers of the Postal Service, and use it to authenticate records of the Postal Service and for other official purposes. The following describes the Seal adopted for the Postal Service:

(1) A stylized bald eagle is poised for flight, facing to the viewer's right, above two horizontal bars between which are the words "U.S. MAIL", surrounded by a square border with rounded corners consisting of the words "UNITED STATES POSTAL SERVICE" on the left, top, and right, and consisting of nine five-pointed stars on the base.

(2) The color representation of the Seal shows, a white field on which the bald eagle appears in dark blue, the words "U.S. MAIL" in black, the bar above the words in red, the bar below in blue, and the entire border consisting of the words "UNITED STATES POSTAL SERVICE" and stars in ochre.

BILLING CODE 7710-12-P



**BILLING CODE 7710-12-C**

(b) The location and description of the Postal Service emblem is described at 39 CFR 221.9.

**§ 2.5 Authority.**

These bylaws are adopted by the Board under the authority conferred upon the Postal Service by 39 U.S.C. 401(2) and 5 U.S.C. 552b(g).

**§ 2.6 Severability, amendment, repeal, and waiver of bylaws.**

The invalidity of any provision of these bylaws does not affect the validity of the remaining provisions, and for this purpose these bylaws are severable. The Board may amend or repeal these bylaws at any special or regular meeting, provided that each member of the Board has received a written notice containing a statement of the proposed amendment or repeal at least 5 days before the meeting. The members of the Board may waive the 5 days' notice or the operation of any other provision of these bylaws by unanimous consent, if that action is not prohibited by law. The Secretary shall submit the text of any amendment to these bylaws for publication in the *Federal Register* as soon as practicable after the amendment is adopted by the Board.

**PART 3—BOARD OF GOVERNORS  
(ARTICLE III)**

**Sec.**

- 3.1 Responsibilities of Board.
- 3.2 Compensation of Board.
- 3.3 Matters reserved for decision by the Board.
- 3.4 Matters reserved for decision by the Governors.
- 3.5 Delegation of authority by Board.
- 3.6 Information furnished to Board—financial and operating reports.
- 3.7 Information furnished to Board—program review.
- 3.8 Information furnished to Board—special reports.

**Authority:** 39 U.S.C. 202, 203, 205, 401(2), (10), 402, 1003, 3013; 5 U.S.C. 552b(g), (j).

**§ 3.1 Responsibilities of Board.**

The composition of the Board is described in 39 U.S.C. 202. The Board directs the exercise of the powers of the Postal Service, reviews the practices and policies of the Postal Service, and directs and controls the expenditures of the Postal Service. Consistent with the broad delegation of authority to the Postmaster General in § 3.5 of these bylaws, and except for those powers, duties, or obligations which the Reorganization Act specifically vests in the Governors, as distinguished from the Board of Governors, the Board accomplishes its purposes by monitoring the operations and performance of the Postal Service, and by establishing basic objectives, broad policies, and long-range goals for the Postal Service.

**§ 3.2 Compensation of Board.**

Section 202(a) of title 39 provides for the compensation of the Governors and for reimbursement for travel and reasonable expenses incurred in attending Board meetings. Compensation is provided for not more than 42 days of meetings per year.

**§ 3.3 Matters reserved for decision by the Board.**

The following matters are reserved for decision by the Board of Governors:

- (a) Election of the Vice Chairman of the Board.
- (b) Adoption of, and amendments to, the bylaws of the Board.
- (c) (1) Approval of the annual Postal Service budget program in both tentative and final form, including requests for appropriations;
- (2) Approval of the annual Postal Service operating budget.
- (d) Approval of the annual financial statements of the Postal Service following receipt of the annual report of

the Postal Service's independent, certified public accounting firm.

(e) Approval of the Postal Service Five-Year Capital Investment Plans, including specific approval of each capital investment project, each new lease/rental agreement, and each research and development project exceeding such amount specified by resolution at the annual Board meeting in January. In the case of any project or agreement subject to the requirement of Board approval under this provision, the expenditure of any funds in excess of the amount previously authorized by the Board must be specifically approved by the Board. For the purpose of determining the cost of a capital investment project, lease/rental agreement, or research and development project,

(1) All such projects and agreements undertaken as part of a unitary plan (either for contemporaneous or sequential development in one of several locations) shall be considered one project or agreement, and

(2) The cost of a lease/rental agreement shall be the present value of all lease payments over the term of the lease, including all periods covered by renewal options or all periods for which failure to renew imposes a penalty or a hardship such that renewal appears to be reasonably assured, plus the cost of any leasehold improvements planned in connection with the lease/rental agreement. The present value will be determined using the cost of capital of the Postal Service.

(f) Authorization of the Postal Service to request the Postal Rate Commission to submit a recommended decision on changes in postal rates.

(g) Authorization of the Postal Service to request the Postal Rate Commission to submit a recommended decision on changes in the mail classification schedule.



(h) Determination of an effective date for changes in postal rates or mail classification.

(i) Authorization of the Postal Service to request the Postal Rate Commission to submit an advisory opinion on a proposed change in the nature of postal services which will generally affect service on a nationwide or substantially nationwide basis.

(j) Approval of any use of the authority of the Postal Service to borrow money under 39 U.S.C. 2005, except for short-term borrowings, having maturities of one year or less, assumed in the normal course of business.

(k) Approval of the terms and conditions of each series of obligations issued by the Postal Service under 39 U.S.C. 2005, including the time and manner of sale and the underwriting arrangements, except for short-term borrowings, having maturities of one year or less, assumed in the normal course of business.

(l) Approval of any use of the authority of the Postal Service to require the Secretary of the Treasury to purchase Postal Service obligations under 39 U.S.C. 2006(b), or to request the Secretary of the Treasury to pledge the full faith and credit of the Government of the United States for the payment of principal and interest on Postal Service obligations under 39 U.S.C. 2006(c).

(m) Determination of the number of officers, described in 39 U.S.C. 204 as Assistant Postmasters General, whether so denominated or not, as the Board authorizes by resolution.

(n) Compensation of officers of the Postal Service whose positions are included in Level II of the Postal Career Executive Service.

(o) Selection of an independent, certified public accounting firm to certify the accuracy of Postal Service financial statements as required by 39 U.S.C. 2008(e).

(p) Approval of official statements adopting major policy positions or departing from established major policy positions, and of official positions on legislative proposals having a major impact on the Postal Service.

(q) Approval of all major policy positions taken with the Department of Justice on petitioning the Supreme Court of the United States for writs of certiorari.

(r) Approval and transmittal to the President and the Congress of the annual report of the Postmaster General under 39 U.S.C. 2402.

(s) Approval and transmittal to the Congress of the annual report of the Board under 5 U.S.C. 552b(j).

(t) Approval of the annual comprehensive statement of the Postal Service to Congress under 39 U.S.C. 2401(g).

(u) Approval and transmittal to the Congress of the semi-annual report of the Postmaster General under 39 U.S.C. 3013, summarizing the investigative activities of the Postal Service.

(v) All other matters that the Board may consider appropriate to reserve for its decision.

#### **§ 3.4 Matters reserved for decision by the Governors.**

The following matters are reserved for decision by the Governors:

(a) Appointment, pay, term of service, and removal of the Postmaster General, 39 U.S.C. 202(c).

(b) Appointment, term of service, and removal of the Deputy Postmaster General (by the Governors and the Postmaster General, 39 U.S.C. 202(d)); pay of the Deputy Postmaster General, 39 U.S.C. 202(d).

(c) Election of the Chairman of the Board of Governors, 39 U.S.C. 202(a).

(d) Approval of the budget of the Postal Rate Commission, or adjustment of the total amount of the budget (by unanimous written vote of the Governors in office, 39 U.S.C. 3604(d)).

(e) Action upon a recommended decision of the Postal Rate Commission, including action to approve, allow under protest, reject, or modify that decision, 39 U.S.C. 3625.

(f) Concurrence of the Governors with the Postmaster General in the removal or transfer of the Chief Postal Inspector under 5 U.S.C. App. 8E(f).

(g) The Governors shall meet annually in closed session to discuss compensation, term of service, and appointment/removal of the Secretary and other necessary staff.

#### **§ 3.5 Delegation of authority by Board.**

As authorized by 39 U.S.C. 402, these bylaws delegate to the Postmaster General the authority to exercise the powers of the Postal Service to the extent that this delegation of authority does not conflict with powers reserved to the Governors or to the Board by law, these bylaws, or resolutions adopted by the Board. Any of the powers delegated to the Postmaster General by these bylaws may be redelegated by the Postmaster General to any officer, employee, or agency of the Postal Service.

#### **§ 3.6 Information furnished to Board—financial and operating reports.**

To enable the Board to monitor the performance of the Postal Service during the most recent accounting

periods for which data are available, postal management shall furnish the Board (on a monthly basis) financial and operating statements for the fiscal year to date, addressing the following categories: (a) Mail volume by class; (b) income and expense by principal categories; (c) balance sheet information; (d) service quality measurements; (e) productivity measurements (reflecting workload and resource utilization); and (f) changes in postal costs. These statements shall include, where applicable, comparable figures for the previous year and the current year's plan.

#### **§ 3.7 Information furnished to Board—program review.**

(a) To enable the Board to review the Postal Service operating program, postal management shall furnish the Board information on all aspects of the Postal Service budget plan, including:

(1) The tentative and final annual budgets submitted to the Office of Management and Budget and the Congress, and amendments to the budget;

(2) Five-year plans, annual operating and investment plans, and significant departures from estimates upon which the plans were based;

(3) The need for rate increases or decreases and the progress of any pending rate cases and related litigation; and

(4) Debt financing needs, including a review of all borrowings of the Postal Service from the U.S. Treasury and private sources.

(b) To enable the Board to review the effectiveness of the Postal Service's equal employment opportunity program, performance data relating to this program shall be furnished to the Board at least quarterly. This data shall be categorized in such manner as the Board, from time to time, specifies.

(c) Postal management shall also regularly furnish the Board information regarding major programs for improving postal service or reducing the cost of postal operations.

(d) Management shall furnish to the Board information regarding any significant new program, major modification or initiative; any plan to offer a significant, new or unique product or system implementation; or any significant, new project not related directly to the core business function of the Postal Service. For the purposes of this paragraph, "significant" means a project anticipated to have a notable or conspicuous impact on (1) corporate visibility or (2) the operating budget or capital investment budget.

**§ 3.8 Information furnished to Board—special reports.**

To insure that the Board receives significant information of developments meriting its attention, postal management shall bring to the Board's attention the following matters:

(a) Major developments in personnel areas, including but not limited to equal employment opportunity, career development and training, and grade and salary structures.

(b) Major litigation activities. Postal management shall also notify the Board in a timely manner whenever it proposes to seek review by any United States Court of Appeals of an adverse judicial decision.

(c) Any significant changes proposed in the Postal Service's system of accounts or methods of accounting.

(d) Matters of special importance, including but not limited to important research and development initiatives, major changes in Postal Service organization or structure, major law enforcement activities, and other matters having a significant impact upon the relationship of the Postal Service with its employees, with any major branch of Government, or with the general public.

(e) Information concerning any proposed grant of unique or exclusive licenses to use Postal Service intellectual properties (other than patents and technical data rights), or any proposed joint venture involving the use of such property.

(f) Other matters having important policy implications.

**PART 4—OFFICERS (ARTICLE IV)**

Sec.

- 4.1 Chairman.
- 4.2 Vice Chairman.
- 4.3 Postmaster General.
- 4.4 Deputy Postmaster General.
- 4.5 Assistant Postmasters General, General Counsel, Judicial Officer.
- 4.6 Chief Postal Inspector.
- 4.7 Secretary of the Board.

Authority: 39 U.S.C. 202, 203, 205, 401(2), (10), 1003, 3013.

**§ 4.1 Chairman.**

(a) The Chairman of the Board of Governors is elected by the Governors from among the members of the Board. The Chairman:

(1) Shall preside at all regular and special meetings of the Board, and shall set the agenda for such meetings;

(2) Shall select and appoint the Chairman and members of any committee properly established by the Board;

(3) Serves a term that commences upon election and expires at the end of

the first annual meeting following the meeting at which he or she was elected.

(b) If the Postmaster General is elected Chairman of the Board, the Governors shall also elect one of their number to preside during proceedings dealing with matters upon which only the Governors may vote.

**§ 4.2 Vice Chairman.**

The Vice Chairman is elected by the Board from among the members of the Board and shall perform the duties and exercise the powers of the Chairman during the Chairman's absence or disability. The Vice Chairman serves a term that commences upon election and expires at the end of the first annual meeting following the meeting at which he or she was elected.

**§ 4.3 Postmaster General.**

The appointment and role of the Postmaster General are described at 39 U.S.C. 202(c), 203. The Governors set the salary of the Postmaster General by resolution, subject to the limitations of 39 U.S.C. 1003(a).

**§ 4.4 Deputy Postmaster General.**

The appointment and role of the Deputy Postmaster General are described at 39 U.S.C. 202(d), 203. The Deputy Postmaster General shall act as Postmaster General during the Postmaster General's absence or disability, and when a vacancy exists in the office of Postmaster General. The Governors set the salary of the Deputy Postmaster General by resolution, subject to the limitations of 39 U.S.C. 1003(a).

**§ 4.5 Assistant Postmasters General, General Counsel, Judicial Officer.**

There are within the Postal Service a General Counsel, a Judicial Officer, and such number of officers, described in 39 U.S.C. 204 as Assistant Postmasters General, whether so denominated or not, as the Board authorizes by resolution. These officers are appointed by, and serve at the pleasure of, the Postmaster General.

**§ 4.6 Chief Postal Inspector.**

The Postmaster General, in consultation with the Governors, appoints the Chief Postal Inspector, certain of whose powers and duties are delegated to the holder of that office by the Postmaster General, consistent with these bylaws and the Reorganization Act. The Chief Postal Inspector also holds the position of Inspector General, and for purposes of the Inspector General Act of 1978, as amended by Public Law 100-504, 5 U.S.C. App. 8E(f), reports to and is under the general supervision of the Postmaster General.

The Postmaster General has the power, with the concurrence of the Governors, to remove or transfer the Chief Postal Inspector to another position or location within the Postal Service. In the event of any such removal or transfer, the Postmaster General must promptly notify both Houses of the Congress in writing of the reasons for such removal or transfer.

**§ 4.7 Secretary of the Board.**

The Secretary of the Board of Governors is appointed by the Governors and serves at the pleasure of the Governors. The Secretary shall be responsible for carrying out the functions of the Office of the Board of Governors, under the direction of the Chairman of the Board. The Secretary shall also issue notices of meetings of the Board and its committees, keep minutes of these meetings, and take steps necessary for compliance with all statutes and regulations dealing with public observation of meetings. The Secretary shall perform all those duties incident to this office, including those duties assigned by the Board or by the Chairman of the Board. The Chairman may designate such assistant secretaries as may be necessary to perform any of the duties of the Secretary.

**PART 5—COMMITTEES (ARTICLE V)**

Sec.

- 5.1 Establishment and appointment.
- 5.2 Committee procedure.

Authority: 39 U.S.C. 202, 203, 204, 205, 401(2), (10), 1003, 3013; 5 U.S.C. 552b (a), (b), (g).

**§ 5.1 Establishment and appointment.**

From time to time the Board may establish by resolution special and standing committees of one or more members of the Board. The Board shall specify, in the resolution establishing any committee, whether the committee is authorized to submit recommendations or preliminary decisions to the Board, to conduct hearings for the Board, or otherwise to take action on behalf of the Board. Each committee may exercise only those duties, functions, and powers prescribed from time to time by the Board, and the Board may affirm, alter, or revoke any action of any committee. Each member of the Board may have access to all of the information and records of any committee at any time. The Chairman of the Board shall appoint the chairman and members of each committee, who serve terms which expire at the end of each annual meeting. Each committee chairman may assign responsibilities to members of the committee that are considered

appropriate. The committee chairman, or the chairman's designee, shall preside at all meetings of the committee.

#### § 5.2 Committee procedure.

Each committee establishes its own rules of procedure, consistent with these bylaws, and meets as provided in its rules. A majority of the members of a committee constitute a quorum, and may take action by majority vote of the members present. Except as specifically provided by statute, every portion of every meeting of every committee of more than one member, which is authorized to submit recommendations or preliminary decisions to the Board, to conduct hearings for the Board, or otherwise to take action on behalf of the Board, is open to public observation, and is subject to the requirements of §§ 7.1 through 7.8 of these bylaws.

### PART 6—MEETINGS (ARTICLE VI)

#### Sec.

- 6.1 Regular meetings, annual meeting.
- 6.2 Special meetings.
- 6.3 Notice of meetings.
- 6.4 Attendance by conference telephone call.
- 6.5 Minutes of meetings.
- 6.6 Quorum and voting.

Authority: 39 U.S.C. 202, 205, 401(2), (10), 1003, 3013; 5 U.S.C 552b (e), (g).

#### § 6.1 Regular meetings, annual meeting.

The Board shall meet regularly each month and shall meet normally on the first Monday and Tuesday of each month. The first regular meeting of each calendar year is designated as the annual meeting. Consistent with the provisions of § 7.5 of these bylaws, the time or place of a regular or annual meeting may be varied by a recorded unanimous vote of the entire membership of the Board, with the earliest practicable notice to the Secretary. The Secretary shall distribute to the members an agenda setting forth the proposed subject matter for any regular or annual meeting in advance of the meeting.

#### § 6.2 Special meetings.

Consistent with the provisions of § 7.5 of these bylaws, the Chairman may call a special meeting of the Board at any place in the United States, with not less than 8 days' notice to the other members of the Board and to the Secretary, specifying the time, date, place, and subject matter of the meeting. By recorded vote a majority of the members of the Board may call a special meeting of the Board at any place in the United States, with the earliest practicable notice to the other members of the Board and to the Secretary, specifying

the time, date, place and subject matter of the meeting.

#### § 6.3 Notice of meetings.

The Chairman or the members of the Board may give the notice required under § 6.1 or § 6.2 of these bylaws in oral or written form. Oral notice to a member may be delivered by telephone and is sufficient if made to the member personally or to a responsible person in the member's home or office. Any oral notice to a member must be subsequently confirmed by written notice. Written notice to a member may be delivered by telegram or by mail sent by the fastest regular delivery method addressed to the member's address of record filed with the Secretary, and except for written notice confirming a previous oral notice, must be sent in sufficient time to reach that address at least 2 days before the meeting date under normal delivery conditions. A member waives notice of any meeting by attending the meeting, and may otherwise waive notice of any meeting at any time. Neither oral nor written notice to the Secretary is sufficient until actually received by the Secretary. The Secretary may not waive notice of any meeting.

#### § 6.4 Attendance by conference telephone call.

Unless prohibited by law or by these bylaws, a member of the Board may participate in a meeting of the Board by conference telephone or similar communication equipment which enables all persons participating in the meeting to hear each other and which permits full compliance with the provisions of these bylaws concerning public observation of meetings. Attendance at a meeting by this method constitutes presence at the meeting, except that no Governor may receive compensation for any meeting attended in this manner.

#### § 6.5 Minutes of meetings.

The Secretary shall preserve the minutes of Board meetings prepared under § 4.7 of these bylaws. After the minutes of any meeting are approved by the Board, the Secretary shall promptly make available to the public, in the Communications Department at Postal Service Headquarters, or in another place easily accessible to the public, copies of the minutes, except for those portions which contain information inappropriate for public disclosure under 5 U.S.C. 552(b) or 39 U.S.C. 410(c).

#### § 6.6 Quorum and voting.

As provided by 39 U.S.C. 205(c), the Board acts by resolution upon a majority

vote of those members who are present. No proxies are allowed in any vote of the members of the Board. Any 6 members constitute a quorum for the transaction of business by the Board, except:

(a) In the appointment or removal of the Postmaster General, and in setting the compensation of the Postmaster General and Deputy Postmaster General, 39 U.S.C. 205(c)(1) requires a favorable vote of an absolute majority of the Governors in office;

(b) In the appointment or removal of the Deputy Postmaster General, 39 U.S.C. 205(c)(2) requires a favorable vote of an absolute majority of the Governors in office and the Postmaster General;

(c) In the appointment, removal, or in the setting of the compensation of the Secretary, Assistant Secretary, or other necessary staff, a favorable vote of an absolute majority of the Governors in office is required;

(d) In the adjustment of the total budget of the Postal Rate Commission, 39 U.S.C. 3604(c) requires a unanimous written vote of the Governors in office;

(e) In the modification of a recommended decision of the Postal Rate Commission, 39 U.S.C. 3625 requires a unanimous written vote of the Governors in office; and

(f) In the approval, allowance under protest, or rejection of a recommended decision of the Postal Rate Commission, the Governors act upon a majority vote of the Governors present, and the required quorum of 6 members must include at least 5 Governors;

(g) In the determination to close a portion of a meeting or to withhold information concerning a meeting, 5 U.S.C. 552b(d)(1) requires a vote of a majority of the entire membership of the Board; and

(h) In the decision to call a meeting with less than a week's notice, 5 U.S.C. 552b(e)(1) requires a vote of a majority of the members of the Board. In the decision to change the subject matter of a meeting, or the determination to open or close a meeting, 5 U.S.C. 552b(e)(2) requires a vote of a majority of the entire membership of the Board.

### PART 7—PUBLIC OBSERVATION (ARTICLE VII)

#### Sec.

- 7.1 Definitions.
- 7.2 Open meetings.
- 7.3 Exceptions.
- 7.4 Procedure for closing a meeting.
- 7.5 Public notice of meetings, subsequent changes.
- 7.6 Certification and transcripts of closed meetings.
- 7.7 Enforcement.

7.8 Open meetings, Freedom of Information, and Privacy of Information.

**Authority:** 39 U.S.C. 401(a), as enacted by Pub. L. 91-375, and 5 U.S.C. 552b(a)-(m) as enacted by Pub. L. 94-409.

**§ 7.1 Definitions.**

For purposes of §§ 7.2 through 7.8 of these bylaws:

(a) The term "Board" means the Board of Governors, and any subdivision or committee of the Board authorized under § 5.1 of these bylaws to submit recommendations or preliminary decisions to the Board, to conduct hearings for the Board, or otherwise to take action on behalf of the Board.

(b) The term "meeting" means the deliberations of at least the number of individual members required to take action on behalf of the Board under § 5.2 or § 6.5 of these bylaws, where such deliberations determine or result in the joint conduct or disposition of the official business of the Board. The term "meeting" does not include any procedural deliberations required or permitted by §§ 6.1, 6.2, 7.4, or § 7.5 of these bylaws.

**§ 7.2 Open meetings.**

(a) It is the policy of the United States, established in section 2 of the Government in the Sunshine Act, Public Law 94-409, 90 Stat. 1241, that the public is entitled to the fullest practicable information regarding the decisionmaking processes of the Federal Government. The Postal Service is charged to provide the public with this information while protecting the rights of individuals and the ability of the Government to carry out its responsibilities. Accordingly, except as specifically permitted by statute, every portion of every meeting of the Board of Governors is open to public observation.

(b) Except as provided in § 7.3 of these bylaws, every portion of every meeting of the Board is open to public observation. Members of the Board may not jointly conduct or dispose of business of the Board without complying with §§ 7.2 through 7.8 of these bylaws. Members of the public may obtain access to documents considered at meetings to the extent provided in the regulations of the Postal Service concerning the release of information.

(c) Without the permission of a majority of the Board, no person may participate in, film, televise, or broadcast any portion of any meeting of the Board. Any person may electronically record or photograph a meeting, as long as that action does not tend to impede or disturb the members of the Board in the performance of their

duties, or members of the public while attempting to attend or observe a meeting of the Board. The rules and penalties of 39 CFR 232.6, concerning conduct on postal property, apply with regard to meetings of the Board.

**§ 7.3 Exceptions.**

Section 7.2 of these bylaws does not apply to a portion of a meeting, and §§ 7.4 and 7.5 do not apply to information concerning the meeting which otherwise would be required to be disclosed to the public, if the Board properly determines that the public interest does not require otherwise, and that such portion of the meeting or the disclosure of such information is likely to:

(a) Disclose matters that are (1) specifically authorized under criteria established by an Executive order to be kept secret in the interests of national defense or foreign policy, and (2) in fact properly classified under that Executive order;

(b) Relate solely to the internal personnel rules and practices of the Postal Service, including the Postal Service position in negotiations or consultations with employee organizations.

(c) Disclose matters specifically exempted from disclosure by statute (other than the Freedom of Information Act, 5 U.S.C. 552), provided that the statute (1) requires that the matters be withheld from the public in such a manner as to leave no discretion on the issue, or (2) establishes particular criteria for withholding or refers to particular types of matters to be withheld;

(d) Disclose trade secrets and commercial or financial information obtained from a person and privileged or confidential, such as market information pertinent to Postal Service borrowing or investments, technical or patent information related to postal mechanization, or commercial information related to purchases of real estate;

(e) Involve accusing any person of a crime, or formally censuring any person;

(f) Disclose information of a personal nature, such as personal or medical data regarding any individual if disclosure would constitute a clearly unwarranted invasion of personal privacy;

(g) Disclose investigatory records compiled for law enforcement purposes, or information which if written would be contained in those records, but only to the extent that the production of those records or information would (1) interfere with enforcement proceedings, (2) deprive a person of a right to a fair trial or an impartial adjudication, (3)

constitute an unwarranted invasion of personal privacy, (4) disclose the identity of a confidential source and, in the case of a record compiled by a criminal law enforcement authority in the course of a criminal investigation, or by an agency conducting a lawful national security intelligence investigation, confidential information furnished only by the confidential source, (5) disclose investigative techniques and procedures, or (6) endanger the life or physical safety of law enforcement personnel;

(h) Disclose information contained in or related to examination, operating, or condition reports prepared by, on behalf of, or for the use of an agency responsible for the regulation or supervision of financial institutions;

(i) Disclose information the premature disclosure of which would be likely significantly to frustrate implementation of a proposed action of the Board, such as information relating to the negotiation of a labor contract or proposed Postal Service procurement activity, except that this provision does not apply in any instance where (1) the Postal Service has already disclosed to the public the content or nature of the proposed action, or (2) the Postal Service is required by law to make such disclosure on its own initiative before taking final action on the proposal; or

(j) Specifically concern the issuance of a subpoena by the Postal Service, or the participation of the Postal Service in a civil action or proceeding, such as a postal rate or classification proceeding, an action in a foreign court or international tribunal, or an arbitration, or the initiation, conduct, or disposition by the Postal Service of a particular case of formal adjudication under the procedures of 5 U.S.C. 554 or otherwise involving a determination on the record after opportunity for a hearing.

**§ 7.4 Procedure for closing a meeting.**

(a) A majority of the entire membership of the Board may vote to close a portion of a meeting or to withhold information concerning a meeting under the provisions of § 7.3 of these bylaws. The members shall take a separate vote with respect to each meeting a portion of which is proposed to be closed to the public, or with respect to any information which is proposed to be withheld, and shall make every reasonable effort to take any such vote at least 8 days before the date of the meeting involved. The members may take a single vote with respect to a series of meetings, portions of which are proposed to be closed to the public, or with respect to information concerning the series, so long as each

portion of a meeting in the series involves the same particular matters, and no portion of any meeting is scheduled to be held more than 30 days after the initial portion of the first meeting in the series.

(b) Whenever any person whose interest may be directly affected by a portion of a meeting requests that the Board close that portion to the public for any of the reasons referred to in § 7.3 (e), (f), or (g) of these bylaws, upon request of any one of its members the Board shall vote by recorded vote whether to close that portion of the meeting.

(c) The Secretary shall record the vote of each member participating in a vote under paragraph (a) or (b) of this section. Within 1 day of any vote under paragraph (a) or (b) of this section, the Secretary shall make publicly available a written copy of the vote showing the vote of each member on the question. If a portion of a meeting is to be closed to the public, the Secretary shall, within 1 day of the vote, make publicly available a full written explanation of the action closing the portion, together with a list of all persons expected to attend the meeting and their affiliation.

(d) If a committee of the Board determines that a majority of its meetings may properly be closed to the public for any combination of reasons referred to in § 7.3 (d), (h), or (j) of these bylaws, it may close a meeting or a portion of a meeting by a recorded vote of a majority of its members at the beginning of the meeting or portion in question. The Secretary shall promptly make available to the public a written copy of the vote showing the vote of each member on the question. Paragraphs (a), (b), and (c) of this section, and § 7.5 of these bylaws do not apply to any meeting or portion of a meeting closed under this paragraph. However, at the earliest practicable time, the Secretary shall publicly announce the time, place, and subject matter of the meeting and each of its portions.

(e) Immediately following each public announcement required under paragraphs (c) and (d) of this section, the Secretary shall submit for publication in the *Federal Register* the text of the announcement or the information made available. The Secretary shall also submit the announcement or information to the Postal Service Public and Employee Communications Department for dissemination to the public.

#### **§ 7.5 Public notice of meetings, subsequent changes.**

(a) At least one week before any meeting of the Board, the Secretary shall publicly announce the time, date, place, and subject matter of the meeting, whether it is to be open or closed to the public, and the name and phone number of the official designated by the Board to respond to requests for information about the meeting.

(b) By a recorded vote, a majority of the members of the Board may determine that the business of the Board requires a meeting to be called with less than a week's notice. At the earliest practicable time, the Secretary shall publicly announce the time, date, place, and subject matter of the meeting, and whether it is to be open or closed to the public.

(c) Following the public announcement required by paragraphs (a) or (b) of this section:

(1) As provided in § 6.1 of these bylaws, the Board may change the time or place of a meeting. At the earliest practicable time, the Secretary shall publicly announce the change.

(2) A majority of the entire membership of the Board may change the subject matter of a meeting, or the determination to open or close a meeting to the public, if it determines by a recorded vote that the change is required by the business of the Board and that no earlier announcement of the change was possible. At the earliest practicable time, the Secretary shall publicly announce the change, and the vote of each member upon the change.

(d) Immediately following each public announcement required under paragraphs (a), (b), or (c) of this section, the Secretary shall submit for publication in the *Federal Register* a notice of the time, date, place, and subject matter of the meeting, whether the meeting is open or closed, any change in the preceding, and the name and phone number of the official designated by the Board to respond to requests for information about the meeting. The Secretary shall also submit the announcement and information to the Postal Service Public and Employee Communications Department for dissemination to the public.

#### **§ 7.6 Certification and transcripts of closed meetings.**

(a) At the beginning of every meeting or portion of a meeting closed under § 7.3 (a) through (j) of these bylaws, the General Counsel shall publicly certify that, in his or her opinion, the meeting or portion of the meeting may be closed to the public, stating each relevant exemptive provision. The Secretary

shall retain this certification, together with a statement from the officer presiding at the meeting which sets forth the time and place of the meeting, and the persons present.

(b) The Secretary shall arrange for a complete transcript or electronic recording adequate to record fully the proceedings to be made of each meeting or portion of a meeting of the Board which is closed to the public. The Secretary shall maintain a complete verbatim copy of the transcript, or a complete electronic recording of each meeting or portion of a meeting closed to the public for at least 2 years after the meeting, or for 1 year after the conclusion of any Postal Service proceeding with respect to which the meeting was held, whichever occurs later.

(c) Except for those items of discussion or testimony which the Board, by a majority vote of those members who are present, determines to contain information which may be withheld under § 7.3 of these bylaws, the Secretary shall promptly make available to the public, in the Public and Employee Communications Department at Postal Service Headquarters, or in another place easily accessible to the public, the transcript or electronic recording of a closed meeting, including the testimony of any witnesses received at the meeting. The Secretary shall furnish a copy of this transcript, or a transcription of this electronic recording disclosing the identity of each speaker, to any person at the actual cost of duplication or transcription.

#### **§ 7.7 Enforcement.**

(a) Under 5 U.S.C. 552b(g), any person may bring a proceeding in the United States Court of Appeals for the District of Columbia to set aside any provisions of these bylaws which are not in accord with the requirements of 5 U.S.C. 552b (a)-(f) and to require the promulgation of provisions that are in accord with those requirements.

(b) Under 5 U.S.C. 552b(h) any person may bring a civil action against the Board in an appropriate U.S. District Court to obtain judicial review of the alleged failure of the Board to comply with 5 U.S.C. 552b (a)-(f). The burden is on the Board to sustain its action. The court may grant appropriate equitable relief, including enjoining future violations, or ordering the Board to make public information improperly withheld from the public.

(c) Under 5 U.S.C. 552b(j) the court may assess against any party reasonable attorney fees and other litigation costs reasonably incurred by any other party who substantially prevails, except that

the court may assess costs against the plaintiff only if the court finds that he initiated the suit primarily for frivolous or dilatory purposes.

**§ 7.8 Open meetings, Freedom of Information, and Privacy of Information.**

The provisions of 5 U.S.C. 552b(c) (1)-(10), enacted by Public Law 94-409, the Government in the Sunshine Act, govern in the case of any request under the Freedom of Information Act, 5 U.S.C. 552, to copy or to inspect the transcripts or electronic recordings described in § 7.6 of these bylaws. Nothing in 5 U.S.C. 552b authorizes the Board to withhold from any individual any record, including the transcripts or electronic recordings described in § 7.6 of these bylaws, to which the individual may otherwise have access under 5 U.S.C. 552a, enacted by the Privacy Act of 1974, Public Law 93-579.

**PART 8—[RESERVED]**

2. Part 11 is added, reading as follows:

**PART 11—ADVISORY BOARDS  
[ARTICLE XI]**

Sec.

11.1 Establishment.

**Authority:** 39 U.S.C. 202, 203, 204, 205, 401(2), (10), 402, 403, 1003, 3013, 5 U.S.C. 552b(a), (b) (g).

**§ 11.1 Establishment.**

The Board of Governors may create such advisory boards as it may deem appropriate and may appoint persons to serve thereon or may delegate such latter authority to the Postmaster General.

**PART 221—GENERAL PRINCIPLES OF ORGANIZATION**

3. The authority citation for part 221 is revised to read as follows:

**Authority:** 39 U.S.C. 201, 202, 203, 204, 207, 401(2), 402, 403, 404; Inspector General Act of 1978, as amended (Pub. L. 95-452, as amended), 5 U.S.C. App. 3.

4. Section 221.9 is added to read as follows:

**§ 221.9 Postal Service emblem.**

The Postal Service emblem, which is identical with the seal, is registered as a trademark and service mark by the U.S. Patent Office. Except for the emblem on official stationery, the emblem must bear one of the following notations: "Reg. U.S. Pat. Off.", "Registered in U.S. Patent Office", or the letter R enclosed within a circle.

**Stanley F. Mires,**

*Chief Counsel, Legislative Division.*

[FR Doc. 94-8589 Filed 4-12-94; 8:45 am]

**BILLING CODE 7710-12-P**

# Federal Register

---

Monday  
April 18, 1994

---

## Part III

### Department of Transportation

---

Federal Aviation Administration

---

14 CFR Parts 121, 125 and 135  
Operator Flight Attendant English  
Language Program; Proposed Rule

**DEPARTMENT OF TRANSPORTATION****Federal Aviation Administration****14 CFR Parts 121, 125 and 135**

[Docket No. 27694; Notice No. 94-11]

RIN 2120-AE98

**Operator Flight Attendant English Language Program****AGENCY:** Federal Aviation Administration, DOT.**ACTION:** Advance notice of proposed rulemaking (ANPRM).

**SUMMARY:** The FAA is considering rulemaking to establish requirements to ensure that flight attendants understand sufficient English language to communicate, coordinate, and perform all required safety related duties. If the FAA actually proposes such a requirement, it would be comparable to regulatory requirements for other crewmembers and dispatchers. Improvements in communication, coordination, and performance of required safety related duties that may result from this regulatory process would benefit crewmembers and passengers.

**DATES:** Comments must be submitted on or before July 18, 1994.

**ADDRESSES:** Comments on this notice should be mailed, in triplicate, to: Federal Aviation Administration, Office of the Chief Counsel, Attention: Rules Docket (AGC-200), Docket No. 27694, 800 Independence Avenue, SW., Washington, DC 20591.

Comments delivered must be marked Docket No. 27694. Comments may be examined in room 915G weekdays between 8:30 a.m. and 5 p.m., except on Federal holidays.

**FOR FURTHER INFORMATION CONTACT:** Donell Pollard, Project Development Branch, AFS-203, Air Transportation Division, Office of Flight Standards, Federal Aviation Administration, 800 Independence Avenue, SW., Washington, DC 20591; telephone (202) 267-3735.

**SUPPLEMENTARY INFORMATION:****Comments Invited**

Interested persons are invited to participate in the making of a proposed rule by submitting such written data, views, or arguments as they may desire. Comments relating to the environmental, energy, federalism, or economic impact that might result from any future rulemaking action are also invited. Substantive comments should be accompanied by cost estimates. Communications should identify the

regulatory docket or notice number and should be submitted in triplicate to the Rules Docket address specified above. All communications received on or before the closing date for comments specified will be considered by the Administrator before rulemaking action is taken. All comments received will be available, both before and after the closing date for comment, in the Rules Docket for examination by interested persons. A report summarizing each substantive public contact with Federal Aviation Administration (FAA) personnel concerned with this rulemaking will be filed in the docket. Persons wishing the FAA to acknowledge receipt of their comments must include a preaddressed, stamped postcard on which the following statement is made: "Comments to Docket No. 27694." The postcard will be date stamped and mailed to the commenter.

**Availability of ANPRM**

Any person may obtain a copy of this ANPRM by submitting a request to the Federal Aviation Administration, Office of Public Affairs, Attention: Public Inquiry Center, APA-230, 800 Independence Avenue, SW., Washington, DC 20591, or by calling (202) 267-3484. Communications must identify the notice number of this ANPRM.

Persons interested in being placed on the mailing list for future rulemaking actions should request from the above office a copy of Advisory Circular No. 11-2A, Notice of Proposed Rulemaking Distribution System, which describes the application procedure.

**Background**

It is essential that all flight crewmembers, dispatchers, and air traffic controllers, be able to communicate with each other. Sections 61.83, 61.103, and 61.123 of the Federal Aviation Regulations (FAR) require that a person, in order to be eligible to receive a special pilot certificate without limitations, be able to read, write, and understand the English language. Section 61.151 of the FAR requires that a person, in order to be eligible for an airline transport pilot certificate, to be able to read, write, and understand the English language and speak it without accent or impediment of speech that would interfere with two-way radio conversation. Additionally, persons eligible to be flight engineers, navigators, and dispatchers are required to be able to read, write and understand the English language. The primary objective of these rules is to insure communication and coordination

among crewmembers and others who have duties related to the safe operation of a flight. The Aviation Rulemaking Advisory Committee, an entity comprised of aviation related organizations that advise the FAA on various regulatory issues, has stated that it is inconsistent to assign flight attendants safety related duties aboard flights without ensuring that they have the ability to effectively communicate and coordinate these duties with other crewmembers.

**Possible Rulemaking**

This notice is to inform the public that the FAA is considering amending the applicable portions of parts 121, 125 and 135 of the FAR by requiring certificate holders to establish a program to ensure that flight attendants understand sufficient English to communicate, coordinate and perform all required safety related duties.

The FAA is issuing this Advance Notice of Proposed Rulemaking to gather operational and economic data for use in determining whether to develop a Notice of Proposed Rulemaking (NPRM). The FAA is seeking information in the following specific areas:

*Nature of the Problem*

(1) What are the safety related duties that would be affected by lack of proficiency in the English language?

(2) What are the actual or potential safety related problems, if any, caused by a lack of English language proficiency on the part of the flight attendants?

(3) What level of understanding and fluency should a flight attendant have in order to perform safety related duties?

(4) What constitutes sufficient English language proficiency for operations conducted by the certificate holders?

*Extent of the Problem*

(5) How many flight attendants are serving with United States operators who do not possess English language proficiency? (Please provide information regarding the basis, source or criteria used to formulate the number of flight attendants that do not possess English language proficiency.)

*Cost*

(6) What would be the average cost of training each flight attendant who is not proficient in the English language, to the extent necessary, to be proficient in the English language?

(7) What would be the cost of replacing a flight attendant who is not proficient in the English language?



(8) Would there be a need to hire additional personnel to train flight attendants who are not proficient in the English language?

#### *Present Practices*

(9) How are flight attendants, who are not proficient in the English language, given duty assignments?

(10) Is an effort made to have at least one English speaking flight attendant on each flight?

(11) Are flight attendants, who are not proficient in the English language, routinely assigned to certain positions on a flight?

(12) When foreign operators function with flight attendants who do not speak the language of the operator or English, how are these flight attendants assigned to positions on the flight?

(13) How do foreign governments ensure that flight attendants possess the language skills necessary to perform crew coordination duties?

#### *Method of Ensuring Proficiency*

(14) What type of program, procedures, or standard should be used to ensure that flight attendants possess the necessary proficiency in the English language to communicate, coordinate and perform all safety related duties?

(15) Should all flight attendants be proficient in the English language? If not, why not?

(16) What percentage of flight attendants on a flight should be proficient in the English language? (Please provide the basis for your analysis).

#### **Regulatory Process Matters**

##### *Economic Impact*

The FAA is presently unable to determine the likely costs of imposing regulations affecting an operator flight attendant English language program. Following a review of the responses submitted to this ANPRM, the FAA will determine what regulatory requirements will be proposed, if any, and will review the potential costs and benefits, as required by Executive Order 12866. As discussed above, the FAA is seeking relevant cost data to facilitate the FAA's determinations.

##### *Other Regulatory Matters*

At this preliminary stage, it is not possible to determine whether there will be a significant economic impact on a substantial number of small entities or what the paperwork burden might be. These regulatory matters will be addressed at the time of publication of any NPRM on this subject.

#### *Federalism Implications*

Federalism implications, if any, will be discussed if an NPRM is issued.

#### **List of Subjects**

##### *14 CFR Part 121*

Aircraft, Airmen, Aviation safety, Safety.

##### *14 CFR Part 125*

Aircraft, Airmen, Aviation safety.

##### *14 CFR Part 135*

Air taxes, Aircraft, Airmen, Aviation safety.

**Authority:** [for Part 121] 49 U.S.C. app. 1354(a), 1355, 1356, 1357, 1401, 1421-1430, 1472, 1485, and 1502; 49 U.S.C. 106(g) (Revised Pub. L. 97-449, January 12, 1983).

**Authority:** [for Part 125] 49 U.S.C. 1354, 1421 through 1430, and 1502; 49 U.S.C. 106(g) (Revised Pub. L. 97-449, January 12, 1983).

**Authority:** [for Part 135] 49 U.S.C. 1354(a), 1355(a), 1421 through 1431, and 1502; 49 U.S.C. 106(g) (Revised Pub. L. 97-449, January 12, 1983).

Issued in Washington, DC, on April 8, 1994.

**Thomas C. Accardi,**

*Director, Flight Standards Service.*

[FR Doc. 94-9221 Filed 4-15-94; 8:45 am]

BILLING CODE 4910-13-M

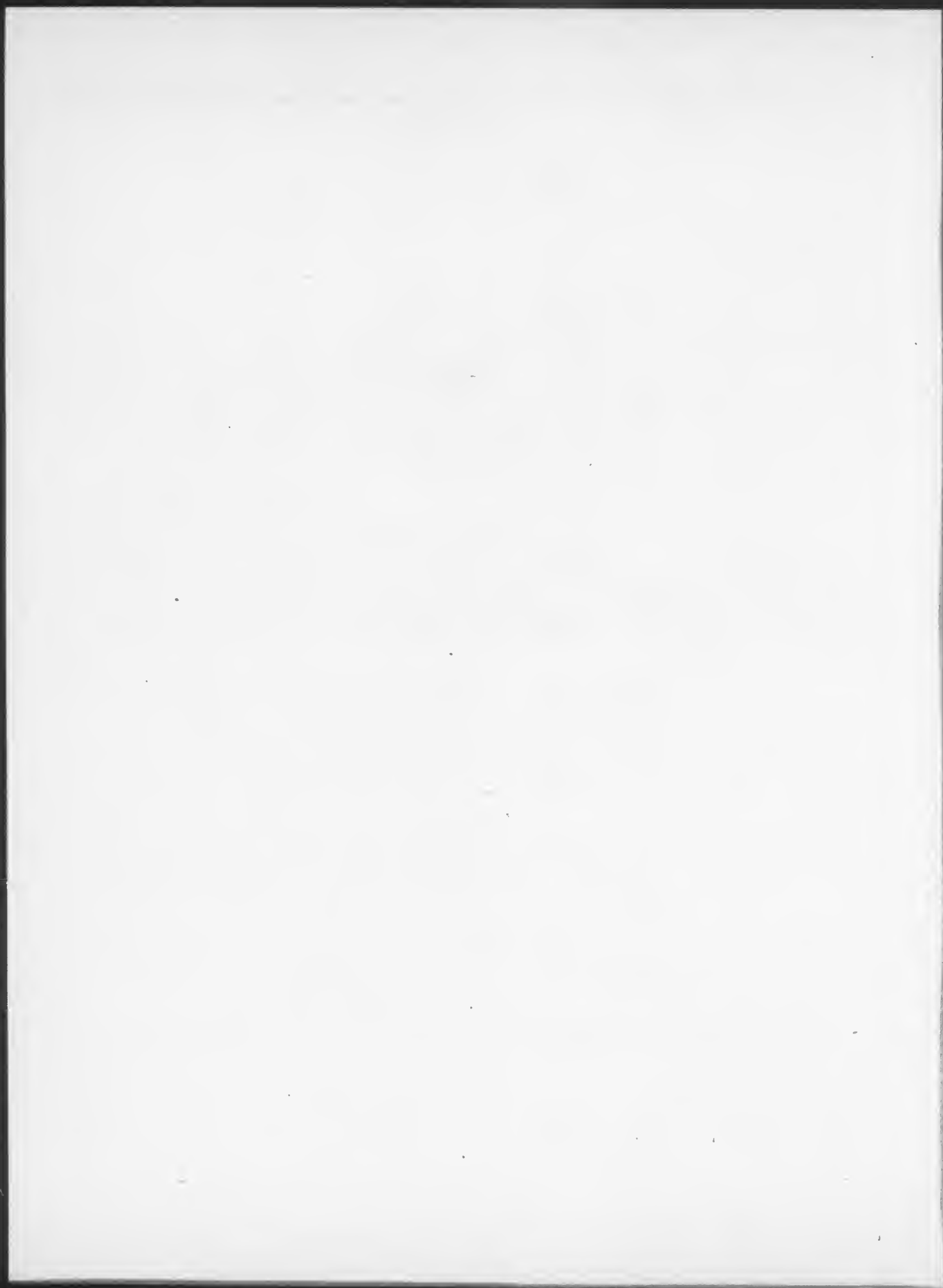

FRIDAY  
APRIL 18, 1994  
DEPARTMENT OF THE  
INTERIOR  
BUREAU OF INDIAN AFFAIRS  
25 CFR PART 40  
ADMINISTRATION OF EDUCATIONAL LOANS,  
GRANTS AND OTHER ASSISTANCE FOR HIGHER  
EDUCATION; PROPOSED RULE

---

Monday  
April 18, 1994

---

**Part IV**

**Department of the  
Interior**

---

**Bureau of Indian Affairs**

---

**25 CFR Part 40  
Administration of Educational Loans,  
Grants and Other Assistance for Higher  
Education; Proposed Rule**

**DEPARTMENT OF THE INTERIOR****Bureau of Indian Affairs****25 CFR Part 40**

RIN 1076-AA10

**Administration of Educational Loans, Grants and Other Assistance for Higher Education****AGENCY:** Bureau of Indian Affairs, Interior.**ACTION:** Proposed rule.

**SUMMARY:** The Bureau of Indian Affairs (BIA) proposes to revise part 40 of Chapter I, title 25 of the Code of Federal Regulations, to ensure consistency with U.S. Department of Education student financial assistance program regulations, to implement requirements of a court decision regarding eligibility, and to change the title of part 40 to "Higher Education Grant Program". Loans to individual Indians are provided for in 25 CFR part 101 and are, therefore, removed from this part.

**DATES:** Public comments must be received on or before July 18, 1994.

**ADDRESSES:** Comments are to be mailed to the Director, Office of Indian Education Programs, Bureau of Indian Affairs, Department of the Interior, 1849 C Street NW., Mail Stop 3530-MIB, Washington, DC 20240. Alternately, comments may be hand delivered to room 3510 at the above address.

**FOR FURTHER INFORMATION CONTACT:** Garry R. Martin, at telephone (202) 208-4871.

**SUPPLEMENTARY INFORMATION:** The United States Department of Education published regulations in March 1975 setting forth the manner in which student financial assistance programs are administered. In the absence of regulations specific to the Bureau's Higher Education Program and eligible Indian students, recipient institutions of higher education often do not understand the purpose of the Bureau's program. These regulations are proposed to clarify the program and remedy inconsistent practices.

The Bureau previously defined applicants for assistance under the Higher Education Grant Program to mean a person who is recognized as a member of an Indian tribe by the Secretary of the Interior and who has at least one-fourth degree Indian blood, Alaska Native, Eskimo or Aleut blood. However, the U.S. Court of Appeals for the Ninth Circuit has ruled that such ¼ blood requirement was not in accordance with the Indian Reorganization Act (IRA), the

authorizing statute that was cited as authority for the regulation. *Zarr v. Barlow*, 800 F.2d 1484 (9th Cir. 1986). The authority used for the Higher Education Grant Program is the Snyder Act, which places no limitation on the definition of Indian.

The definition in BIA elementary and secondary education programs, "an eligible Indian student is a student who is a member of or is at least a one-fourth degree Indian blood descendant of a member of an Indian tribe which is eligible for the special programs and services provided by the United States through the Bureau of Indian Affairs to Indians because of their status as Indians", (Section 2008(f) of 25 U.S.C.), is used.

For purposes of this part, the definition is, therefore, revised. Comments are especially desired on this section of eligibility.

On March 3, 1987, the Bureau published proposed Higher Education Grant Program rules in the Federal Register. In January 1991, the Bureau conducted consultation meetings with Indian tribes, parents, school boards, and other interested parties concerning the Higher Education Grant Program regulations. Oral testimony and written statements were received in the Office of Indian Education Programs until February 26, 1991. The Bureau considered the comments, objections, and suggested changes received in response to the 1987 Federal Register publication and the 1991 consultation meetings in re-proposing these regulations.

The information and record-keeping requirements contained in this part have been submitted to the Office of Management and Budget for approval as required by 44 U.S.C. 3501 *et seq.* The collection of this information will not be required until approved by the Office of Management and Budget.

The policy of the Department of the Interior is, whenever practical, to afford the public an opportunity to participate in the rulemaking process. Accordingly, interested persons may submit written comments regarding the proposed rule, by the date specified in the Dates section, to the location identified in the Addresses section of this document.

The primary author of this document is Mr. Harvey Jacobs, Jr., Branch of Post Secondary Education, Office of Indian Education Programs.

The Department of the Interior has determined that this proposed rule does not constitute a major Federal action significantly affecting the quality of the human environment and that no detailed statement is required pursuant

to the National Environmental Policy Act of 1969.

This document is not a significant regulatory action under Executive Order 12866 and therefore will not be reviewed by the Office of Management and Budget. This rule will not have a significant impact on a substantial number of small entities within the meaning of the Regulatory Flexibility Act (5 U.S.C. 606 *et seq.*). These regulations will affect only the delivery of higher education services to eligible, individual Indian students. They will not have an impact on small entities as defined in the Act.

**List of Subjects in 25 CFR Part 40**

Grant programs—Higher Education, Grant programs—Indians, Grant programs—education, Indians—education, Student aid, Record keeping requirements.

For reasons set out in the Preamble, part 40 of subchapter E of chapter I, title 25 of the Code of Federal Regulations is proposed to be revised as set forth below.

**PART 40—HIGHER EDUCATION GRANT PROGRAM****Subpart A—General Provisions****Sec.**

- 40.1 Purpose and scope.
- 40.2 Definitions.
- 40.3 Program objective.
- 40.4 Information collection.
- 40.5 Prioritization of grants.
- 40.6 Allowable administrative costs.

**Subpart B—Direct Student Grants**

- 40.11 Eligible applicants.
- 40.12 Filing applications.
- 40.13 Application review.
- 40.14 Time period for a grant.
- 40.15 Duration of student eligibility.
- 40.16 Notification of grant award or denial.
- 40.17 Payment of grant.
- 40.18 Effect of termination of enrollment.
- 40.19 Effect of academic probation or suspension.
- 40.20 Appeals
- 40.21 Records and reporting.

**Authority:** 25 U.S.C. 2, 9, and 13; Reorganization Plan No. 3 of 1950 (65 Stat. 1262).

**Subpart A—General Provisions****§ 40.1 Purpose and scope.**

The Higher Education Grant Program, administered under authority of the Snyder Act of November 2, 1921 (25 U.S.C. 13), provides financial assistance to eligible Indian students who have unmet financial needs as determined by the eligible institution's Financial Aid Office.

**§ 40.2 Definitions.**

*Academic year* means a period of time in which a full-time student is expected to complete the equivalent of at least two semesters, two trimesters, or three quarters at institutions that measure academic progress in credit hours.

*Accreditation* means the certification of an institution of higher education by a sanctioned national or regional accrediting agency or association recognized by the Secretary of Education.

*Assistant Secretary* means the Assistant Secretary—Indian Affairs, Department of the Interior.

*Bureau* means the Bureau of Indian Affairs.

*Campus-based aid* means the Federal financial aid programs [i.e., Supplemental Educational Opportunity Grants (SEOG), College Work-Study (CWS), and Perkins Loan] administered by the Financial Aid Office.

*Continuing student* means a grant recipient who is currently enrolled in an eligible institution, and is maintaining satisfactory progress in his or her course of study according to the institution's standards of satisfactory progress.

*Department of Education* means the United States Department of Education.

*Director* means the Director, Office of Indian Education Programs, Bureau of Indian Affairs.

*Eligible institution* means an institution of higher education that is accredited by a national or regional accrediting agency or is a candidate for accreditation, or is a Tribally Controlled Community College or has qualified under the three institutional certification method, established under section 1201(a)(5)(b) of the Higher Education Act of 1965 (20 U.S.C. 1141(a)).

*Financial Aid Office* means the office of an institution of higher education that has responsibility for institutionally administered financial aid.

*Financial aid package* means the institution's document(s) that identifies (identify) the amounts and types of financial aid awarded by the institution and the amount of unmet need.

*Full-time student* means an enrolled student who is carrying a full-time academic workload (other than by correspondence) as determined by the eligible institution, under standards applicable to all students enrolled in that student's particular program.

*Higher Education Office* means the Bureau Education Line Office administering funds appropriated to the Bureau for higher education grants to eligible Indian students.

*Indian* means a person who is a member of, or is at least a ¼ degree

Indian blood descendent of a member of, a federally recognized Indian tribe eligible to receive services from the Department of the Interior.

*Indian tribe* means any Indian Tribe, Band, Nation, Rancheria, Pueblo, Colony or Community, including any Alaska Native village, that is Federally recognized by the United States Government, through the Secretary of the Interior, for special programs and services provided by the Secretary to Indians because of their status as Indians.

*Near reservation* means those areas or communities adjacent or contiguous to reservations which are designated by the Assistant Secretary—Indian Affairs upon recommendations of the local BIA Superintendent. These recommendations shall be based upon consultation with the tribal governing body of those reservations, as locales appropriate for the extension of financial assistance and/or social services, on the basis of the following general criteria:

(a) Number of Indian people native to the reservation residing in the area;

(b) Written designation by the tribal governing body that members of their tribe and family members who are Indian residing in the area are socially, culturally and economically affiliated with their tribe and reservation;

(c) Geographical proximity of the area to the reservation; and

(d) Administrative feasibility of providing an adequate level of services to the area. The Assistant Secretary—Indian Affairs shall designate each approved area and publish the designations in the Federal Register.

*Pell Grant Program* means the program of financial aid for undergraduate students authorized by Title IV—A Subpart 1 of the Higher Education Act of 1965, as amended, and governed by regulations contained in 34 CFR part 690.

*Program plan* means an individualized course of study in which the student, in conjunction with the degree granting institution of higher education, outlines the required courses for the desired degree.

*Secretary* means the Secretary of the Interior.

*Unmet need* means the difference between the student's cost of education and the resources available to defray those costs. Resources available include federal, state and institutional financial aid, excluding Bureau grants.

The Higher Education Office may adjust the unmet need in accordance with the criteria found in 34 CFR part 668.

**§ 40.3 Program objective.**

The objective of the Bureau's Higher Education Grant Program is to provide financial aid to eligible Indian students to obtain an undergraduate degree from an eligible institution.

**§ 40.4 Information collection.**

The information and record-keeping requirements contained in this Part have been submitted to the Office of Management and Budget for approval as required by 44 U.S.C. 3501 *et seq.* The collection of information will not be required until it has been approved by the Office of Management and Budget. The information is collected to determine the eligibility of Indian applicants. The reporting burden of this form is estimated to be an average of three hours per response, which includes time needed for review, gathering and maintaining this form. The information will be used to award grants to Indians for student assistance.

**§ 40.5 Prioritization of grants.**

The Bureau's Higher Education Grant Program shall be implemented for the benefit of eligible Indians, in accordance with a priority plan established for/by the tribes affected by the program. The tribe may decide to set standards in addition to those established under this part.

**§ 40.6 Allowable administrative costs.**

(a) Not more than 15 percent of the funds available may be used to pay for the direct costs chargeable to the program.

(b) The Higher Education Office shall consider the following as direct costs chargeable to the program:

(1) Compensation of employees for the time and effort devoted specifically to the program;

(2) Cost of materials acquired, consumed, or expended specifically for the purpose of the program;

(3) Equipment and other approved capital expenditures; and

(4) Other expenses incurred specifically to carry out the program.

(c) No less than 85 percent of the funds must be used for grants to eligible students.

**Subpart B—Direct Student Grants****§ 40.11 Eligible applicants.**

To be eligible for assistance from funds appropriated to the Bureau for the Higher Education Grant Program, an applicant must:

(a) Be an Indian as defined in Section 40.2;

(b) Be admitted for enrollment as a student in an eligible institution;

(c) Apply for all available campus-based aid in a timely manner.

(d) Have unmet financial need as determined by the eligible institution's Financial Aid Office according to the U.S. Department of Education's standard formula used to evaluate information the student supplies on their standard application form as required under 34 CFR part 668, Student Assistance General Provisions.

#### § 40.12 Filing applications.

The "Bureau of Indian Affairs Higher Education Grant Application" form shall be used by all applicants for grants under this part. The form shall be available at the Higher Education Office.

(a) Applications for grants under this Part shall be submitted to the Higher Education Office administering the program for the affected tribe(s). Those offices shall establish time-frames, including submission deadlines.

(b) A complete application package consists of the following:

(1) A fully completed Bureau Higher Education Grant Application Form;  
 (2) A current Certificate of Indian Blood (CIB) from the tribe or the Bureau certifying that the applicant is a member of a tribe, or if not a member, appropriate documentation to support claim to descent;

(3) A letter of acceptance from an eligible institution (required only for new applicants, transfers and previously suspended students); and

(4) A "financial aid package", prepared and certified by the institution's Financial Aid Office, indicating the student's unmet needs.

(c) Any applications received after the stated closing date will be considered only if funds remain available after grants are made to eligible applicants who met the deadline.

(d) A separate application must be submitted for a summer school program.

#### § 40.13 Application review.

(a) The Higher Education Office shall review each completed application, including the financial aid package, and verify a student's unmet financial need with the Financial Aid Office. Any changes must be supported with appropriate documentation from the applicant or other directly involved party.

(b) Approval of eligible applicants for grants under this Part is to be made by the Education Line Officer in accordance with the tribe's priority plan.

(c) The Higher Education Office may award students no more than the unmet need amount.

(d) Students who reside on the Indian reservations or trust or restricted lands

under the jurisdiction of the Bureau shall receive first priority in funding, in accordance with the priority established under § 40.5. Those residing near the reservation shall be considered afterward.

#### § 40.14 Time period for a grant.

(a) Grants made under this Part are subject to the availability of funds.

(b) Grants may only cover the period of time required by students to complete their first undergraduate baccalaureate course of study under the limitations set out in § 40.16.

#### § 40.15 Duration of student eligibility.

(a) A student is eligible to receive a grant for the period required to complete an undergraduate baccalaureate course of study, as determined by the institution.

(b) The period required to complete the undergraduate baccalaureate course of study may not exceed the full-time equivalent of:

(1) Five (5) academic years for an undergraduate degree or certificate program that normally requires four (4) academic years, or less, of study to complete; or (2) Six (6) academic years for an undergraduate degree or certificate program that normally requires more than four academic years of study to complete, as determined by the institution.

(c) The Higher Education Office may, with appropriate supporting documentation, waive the limitations contained in paragraph (b) of this section, if it determines that the student's failure to complete the program in the time set forth in this section resulted from an undue hardship caused by one of the following:

- (1) The death of a relative of the student;
- (2) An injury or illness of the student; or
- (3) Other special circumstances.

(d) To verify progress toward the completion of an undergraduate baccalaureate course of study, all continuing students shall submit grade reports or transcript(s), as issued by the institution for each term, to the Higher Education Office on an annual basis.

#### § 40.16 Notification of grant award or denial.

The Higher Education Office shall notify each applicant and the Financial Aid Office in writing of their approval or denial. Denial notification shall provide supporting reason for such determination.

#### § 40.17 Payment of grant.

(a) Grants made by the Higher Education Office shall be made available to the applicant in care of the Financial Aid Office of the eligible institution in which he or she is enrolled.

(b) Financial Aid Offices shall disburse grants made under this Part to the recipients according to the disbursement policy of the institution.

#### § 40.18 Effect of termination of enrollment.

(a) A grant recipient who, without justifiable circumstances, fails to enroll; officially or unofficially withdraws; is expelled before completion of the academic term, semester, trimester, or quarter; or fails to meet the academic standards required by the institution during a probation period, shall repay the amount of the grant received from the institution to the Higher Education Office.

(b) A grant recipient who does not enroll, who withdraws, or who is expelled during an academic term shall submit a written notification to the Higher Education Office, within 10 days of his/her failure to enroll, withdrawal or expulsion, with the following information:

(1) The date of withdrawal, expulsion, or failure to enroll

(2) A statement with supporting documentation indicating the reason for withdrawal or expulsion or failure to enroll, including mitigating circumstances, if any; and

(3) A copy of the student's request made to the institution to return, by check or money order payable to the Higher Education Office, any remaining balance of the grant for that academic term.

(c) The student must demonstrate justifiable circumstances to avoid repayment of the grant amount expended upon termination of enrollment for the academic term. Failure to provide documentation for justifiable circumstances will result in termination of the student's eligibility for future grants under this Part and may require the student to repay any portion of the amount received for the academic term. The justifiable circumstances include, but are not limited to:

(1) Withdrawal due to an injury or illness of the student; and

(2) Other special circumstances.

(d) Within 30 days of receipt of the information required in paragraphs (b) and (c) of this section, the Higher Education Office shall determine the portion of the grant that must be repaid, and notify the student.

(e) The Higher Education Office shall make a reasonable effort to contact the student and make arrangements for recovery of the determined amount.

**§ 40.19 Effect of academic probation or suspension.**

(a) Grant recipients shall continue to be eligible for a grant under this Part as long as they maintain the academic standards required by the institution, subject to the time limitations set forth in § 40.16.

(b) A grant recipient on academic probation must complete 12 or more quarter/semester hours during the term and obtain the GPA required by the institution for removal from probationary status.

**§ 40.20 Appeals.**

The decisions of any BIA official under this Part may be appealed pursuant to the procedures in 25 CFR Part 2.

**§ 40.21 Records and reporting.**

(a) The Higher Education Office shall maintain student files, a ledger of all costs, and related records necessary to identify all transactions involving expenditure of funds made available under this Part. Such records shall:

- (1) Identify each recipient's award and status;
- (2) Demonstrate the eligibility of each student assisted under the Program;
- (3) Indicate the amount of each award and the manner in which the need was calculated and met; and
- (4) Identify the students who have terminated their enrollment.

(b) The Higher Education Office shall submit Higher Education Grant Program Annual Reports, for the preceding academic year program, to the Director by December 1.

(c) The Higher Education Office shall maintain a listing of grant recipients.

(d) Each Higher Education Office shall submit any records and information that the Director requires in connection with the administration of the program and shall comply with such requirements as the Director may find necessary to ensure the accuracy of such reports.

Dated: January 31, 1994.

**Ada E. Deer,**

*Assistant Secretary—Indian Affairs.*

[FR Doc. 94-9260 Filed 4-15-94; 8:45 am]

BILLING CODE 4310-02-P

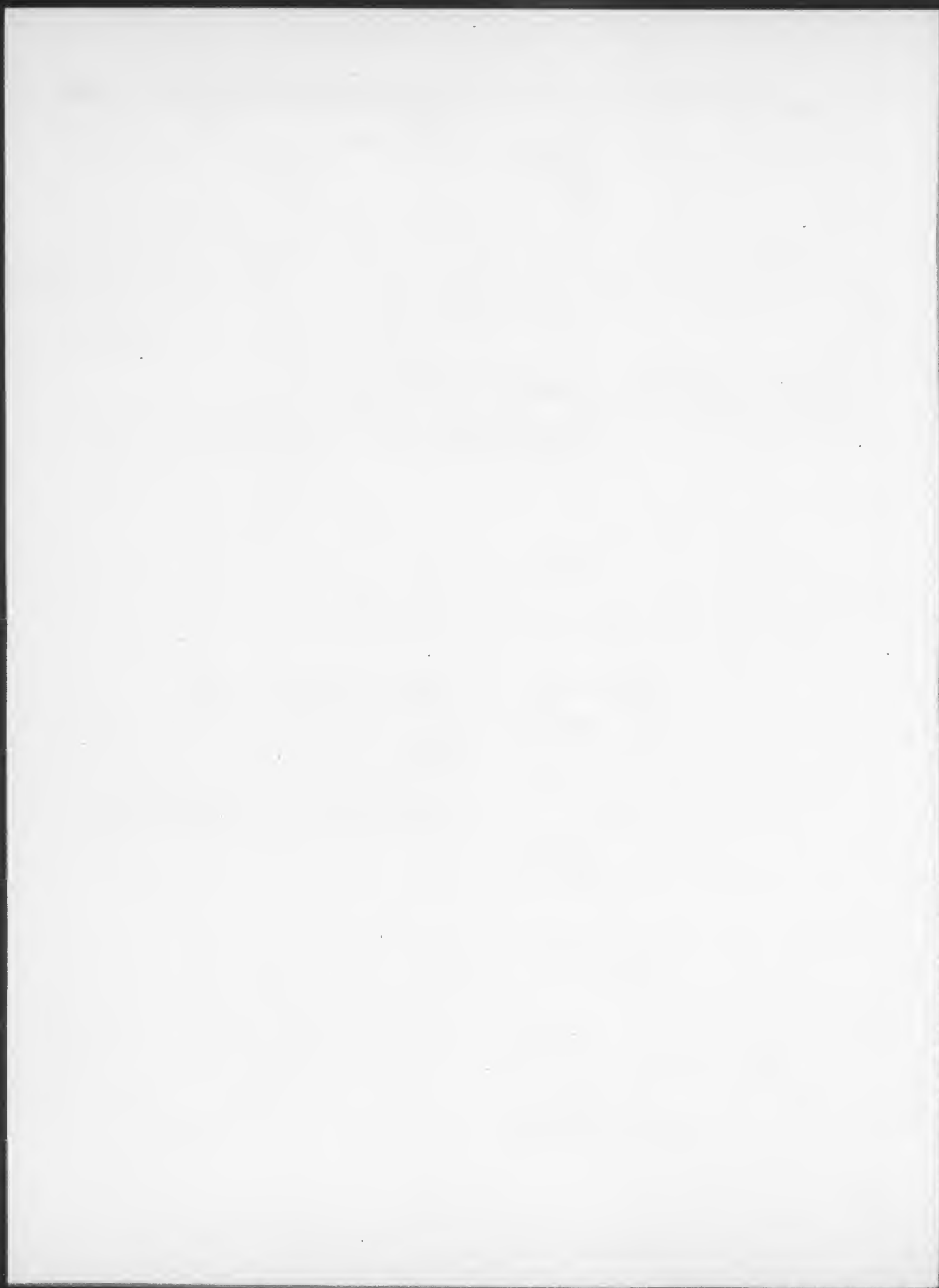



# Federal Register

---

Monday  
April 18, 1994

---

## Part V

### The President

Proclamation 6670—National Park Week,  
1994

Proclamation 6671—Death of Those  
Aboard American Helicopters in Iraq



---

**Presidential Documents**

---

Title 3—

Proclamation 6670 of April 14, 1994

The President

National Park Week, 1994

By the President of the United States of America

**A Proclamation**

Theodore Roosevelt once said that nothing short of defending this country in wartime "compares in importance with the great central task of leaving this land an even better land for our descendants than it is for us . . . ." In the movement to acquire and preserve areas of outstanding scenic or historical significance, Roosevelt blended science and morality in a highly effective and nonpartisan way.

The idea of creating national parks first attracted attention in the second half of the nineteenth century, when America's receding wilderness left our natural resources vulnerable to misuse and exploitation. The Yellowstone National Park Act of 1872 set aside the world's first national park and led the way for Federal protection of exceptional lands for public use.

As the number of early parks increased, many recognized the need for their collective management. The National Park Service was created by an act of Congress signed by President Woodrow Wilson on August 25, 1916. Today, almost 78 years later, the National Park Service oversees 367 national parks, including historic sites, monuments, parks, lakeshores, seashores, rivers, and scenic trails. The growth of the park system is a result of the American public's desire to protect the best and most significant treasures of our Nation.

National parks across the country, from Denali National Park in Alaska to Acadia National Park in Maine, allow us to learn more about our environment; they teach us to respect our lands and to care about endangered plant and animal species. Their spectacular scenic beauty and wide variety of wildlife link man and nature intrinsically and universally. The cultural and historic parks connect us with the spirit of our past and form a national family tree, celebrating our triumphs and remembering our tragedies.

NOW, THEREFORE, I, WILLIAM J. CLINTON, President of the United States of America, by virtue of the authority vested in me by the Constitution and laws of the United States, do hereby proclaim the week of May 23 through May 29, 1994, as "National Park Week." I encourage all Americans to join me in making National Park Week a truly American celebration of our heritage. We are challenged to protect and preserve our parks, to cherish them first, then to teach our children to do the same, so that they, too, can give this gift to their children.

IN WITNESS WHEREOF, I have hereunto set my hand this fourteenth day of April, in the year of our Lord nineteen hundred and ninety-four, and of the Independence of the United States of America the two hundred and eighteenth.

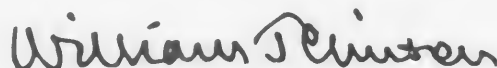

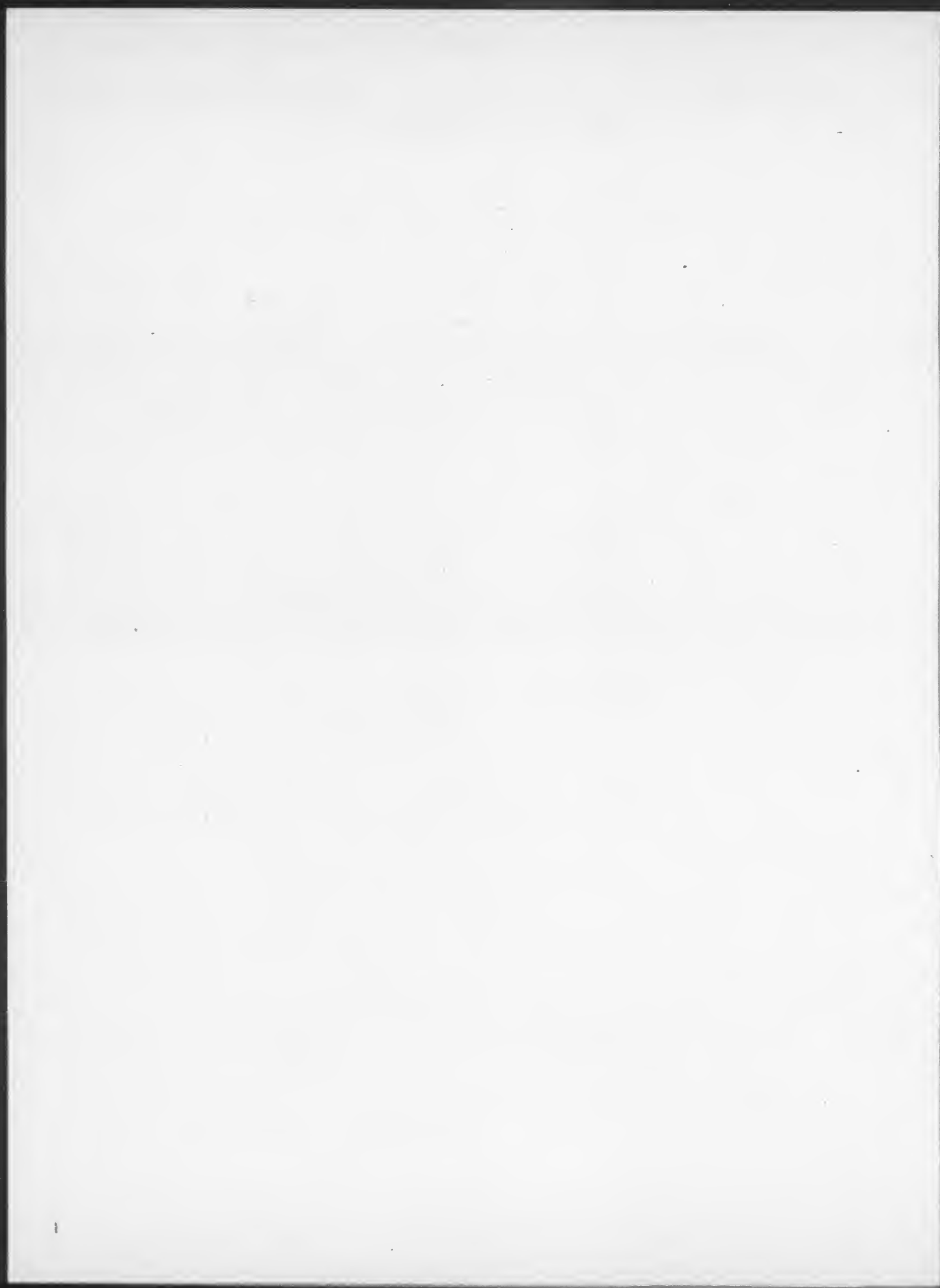

---

**Presidential Documents****Proclamation 6671 of April 14, 1994****Death of Those Aboard American Helicopters in Iraq****By the President of the United States of America****A Proclamation**

As a mark of respect for those who died as a result of the tragic incident in northern Iraq, which occurred on April 14, 1994, I hereby order, by the authority vested in me as President of the United States of America by section 175 of title 36 of the United States Code, that the flag of the United States shall be flown at half-staff upon all public buildings and grounds, at all military posts and naval stations, and on all naval vessels of the Federal Government in the District of Columbia and throughout the United States and its Territories and possessions until sunset, Monday, April 18, 1994. I also direct that the flag shall be flown at half-staff for the same length of time at all United States embassies, legations, consular offices, and other facilities abroad, including all military facilities and naval vessels and stations.

IN WITNESS WHEREOF, I have hereunto set my hand this fourteenth day of April, in the year of our Lord nineteen hundred and ninety-four, and of the Independence of the United States of America the two hundred and eighteenth.

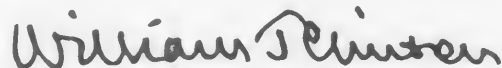

[FR Doc. 94-9478  
Filed 4-15-94; 10:47 am]  
Billing code 3195-01-P

**Editorial note:** For the President's remarks on this tragedy, see issue 15 of the *Weekly Compilation of Presidential Documents*.



# Reader Aids

## Federal Register

Vol. 59, No. 74

Monday, April 18, 1994

### INFORMATION AND ASSISTANCE

<b>Federal Register</b>	
Index, finding aids & general information	202-523-5227
Public inspection desk	523-5215
Corrections to published documents	523-5237
Document drafting information	523-3187
Machine readable documents	523-3447
<b>Code of Federal Regulations</b>	
Index, finding aids & general information	523-5227
Printing schedules	523-3419
<b>Laws</b>	
Public Laws Update Service (numbers, dates, etc.)	523-6641
Additional information	523-5230
<b>Presidential Documents</b>	
Executive orders and proclamations	523-5230
Public Papers of the Presidents	523-5230
Weekly Compilation of Presidential Documents	523-5230
<b>The United States Government Manual</b>	
General information	523-5230
<b>Other Services</b>	
Data base and machine readable specifications	523-3447
Guide to Record Retention Requirements	523-3187
Legal staff	523-4534
Privacy Act Compilation	523-3187
Public Laws Update Service (PLUS)	523-6641
TDD for the hearing impaired	523-5229

### ELECTRONIC BULLETIN BOARD

Free Electronic Bulletin Board service for Public Law numbers, and Federal Register finding aids. 202-275-1538, or 275-0920

### FEDERAL REGISTER PAGES AND DATES, APRIL

15313-15610.....	1
15611-15826.....	4
15827-16088.....	5
16089-16510.....	6
16511-16768.....	7
16769-16960.....	8
16961-17222.....	11
17223-17452.....	12
17453-17674.....	13
17675-17916.....	14
17917-18290.....	15
18291-18470.....	18

### CFR PARTS AFFECTED DURING APRIL

At the end of each month, the Office of the Federal Register publishes separately a List of CFR Sections Affected (LSA), which lists parts and sections affected by documents published since the revision date of each title.

<b>3 CFR</b>	
<b>Administrative Orders:</b>	
<b>Presidential Determinations:</b>	
No. 94-19 of	
March 25, 1994.....	15609
No. 94-20 of	
March 30, 1994.....	17225
No. 94-21 of	
March 30, 1994.....	17227
No. 94-22 of	
April 1, 1994.....	17231
<b>Memorandums:</b>	
March 29, 1994.....	17223
March 30, 1994.....	17229
<b>Executive Orders:</b>	
12906.....	17671
12907.....	18291
<b>Proclamations:</b>	
6661.....	16505
6662.....	16507
6663.....	16769
6664.....	16961
6665.....	17453
6666.....	17455
6667.....	17911
6668.....	18287
6669.....	18289
6670.....	18467
6671.....	18469
<b>5 CFR</b>	
Chapter XLVIII.....	17457
<b>7 CFR</b>	
7.....	15827
110.....	15313
250.....	16963
251.....	16963
271.....	16089
272.....	16089
273.....	16089, 16976
277.....	16089
301.....	17917
792.....	15828
915.....	15313
916.....	15835
917.....	15835
925.....	15611
959.....	17265
1001.....	16511
1002.....	16511
1005.....	15315
1007.....	15315
1011.....	15315
1046.....	15315
1124.....	15318
1135.....	15318
1220.....	15327
1427.....	17917
1610.....	17460
1735.....	17460
1737.....	17460
1744.....	17460
1753.....	17460, 17675
1755.....	17675
1941.....	16771
1943.....	16771
1945.....	16771
1955.....	15966
<b>Proposed Rules:</b>	
28.....	15865
56.....	15866, 17154
110.....	16400
246.....	16148
273.....	17050
704.....	16780
708.....	17495
915.....	15658
944.....	15661
1040.....	17497
1046.....	15348
1126.....	17498
1210.....	17739
1212.....	16571
1410.....	16780
1413.....	16146
<b>8 CFR</b>	
103.....	17920
204.....	17920
<b>Proposed Rules:</b>	
103.....	17283
212.....	17283
217.....	17283
235.....	17283
264.....	17283
286.....	17283
<b>9 CFR</b>	
91.....	17921
78.....	15612
<b>Proposed Rules:</b>	
94.....	17999
95.....	18003
<b>10 CFR</b>	
0.....	17457
1.....	17464
20.....	17464
30.....	17464
40.....	17464
55.....	17464
70.....	17464
73.....	17464
435.....	18293
<b>Proposed Rules:</b>	
20.....	17746
32.....	17286
50.....	17499
61.....	17052
430.....	15868
436.....	17204
830.....	15843
1101.....	16978

<b>11 CFR</b>	<b>19 CFR</b>	1917.....15339, 17478	165.....17507
102.....17267	10.....17473	1918.....17478	<b>34 CFR</b>
<b>12 CFR</b>	42.....17474	1926.....17478	75.....17483
268.....16096	101.....16121	2606.....17694	668.....17648
<b>Proposed Rules:</b>	122.....16121	2610.....17922	670.....17648
304.....15869	175.....16895	2616.....17694	674.....17648
Ch. VI.....15664	<b>21 CFR</b>	2617.....17694	675.....17648
3.....18328	131.....17689	2619.....17924	682.....17170, 17648
<b>13 CFR</b>	173.....15623	2622.....17922	685.....17648
107.....16898, 16933	336.....16981	2644.....17927	690.....17648
121.....16513, 16953	338.....16982	<b>Proposed Rules:</b>	<b>Proposed Rules:</b>
302.....15328	520.....17691, 17693	1910.....15968, 18443	Ch. VI.....15350, 15351
305.....15328	556.....17922	1915.....15968, 17290, 18443	361.....17294
<b>Proposed Rules:</b>	558.....15339, 15624, 17476, 17922, 18296	1926.....15968, 18443	<b>35 CFR</b>
120.....15872	<b>Proposed Rules:</b>	1928.....15968, 18443	<b>Proposed Rules:</b>
<b>14 CFR</b>	101.....16577	<b>30 CFR</b>	133.....18332
39.....15329, 15332, 15613, 15853, 15854, 17467, 17681, 17683, 17685, 17686, 17687, 18294	123.....16578	206.....17479	135.....18332
61.....17644	331.....17747	756.....17748	<b>36 CFR</b>
71.....15616, 15617, 15618, 18296	352.....16042	901.....17928	254.....15501
91.....17550	700.....16042	904.....17931	1191.....17442
93.....15332	740.....16042	906.....17931	<b>Proposed Rules:</b>
97.....15619, 16119	1240.....16578	914.....17928	1.....15350
141.....17644	<b>22 CFR</b>	915.....17931	2.....15350
<b>Proposed Rules:</b>	126.....15624	917.....17928	3.....15350
27.....17156	514.....16983	918.....17931	4.....15350
29.....17156	<b>Proposed Rules:</b>	920.....17928	5.....15350
34.....17640	42.....18010	924.....17928	6.....15350
39.....15348, 15873, 15875, 16151, 16574, 17288	502.....17057	925.....17931	7.....15350
61.....17162	<b>24 CFR</b>	926.....17931	261.....17508
71.....15665, 15666, 15667, 15668, 15669, 15670, 15671, 16153, 16155, 17055, 17056, 18329	50.....17194	931.....17931	262.....17508
91.....15350	574.....17194	935.....17928	1234.....16580
121.....17166, 18456	888.....16408	938.....17928	<b>37 CFR</b>
125.....18456	945.....17652	943.....17931	1.....18300
135.....15350, 18456	960.....17652	944.....16538, 17931	<b>38 CFR</b>
<b>15 CFR</b>	<b>Proposed Rules:</b>	944.....17931	<b>Proposed Rules:</b>
771.....15621	290.....17500	946.....17928	4.....17295
774.....15621	<b>25 CFR</b>	948.....17928	<b>39 CFR</b>
<b>16 CFR</b>	248.....16756	<b>Proposed Rules:</b>	1.....18446
<b>Proposed Rules:</b>	<b>Proposed Rules:</b>	220.....17504	2.....18446
22.....18004	20.....16720	764.....16156	3.....18446
236.....18005	40.....18460	906.....16578	4.....18446
252.....18005	113.....16760	914.....18330	5.....18446
253.....18006	256.....16726	942.....16156	6.....18446
429.....18007	<b>26 CFR</b>	<b>31 CFR</b>	7.....18446
444.....18009	1.....15501, 15502, 16984, 17154, 17477	500.....16775	8.....18446
<b>17 CFR</b>	602.....17154	505.....16775	11.....18446
190.....17468	<b>Proposed Rules:</b>	520.....16775	111.....17484
270.....15501	1.....15877, 17747, 18011, 18048	580.....15342, 16548	221.....18446
<b>Proposed Rules:</b>	31.....18057	<b>32 CFR</b>	<b>Proposed Rules:</b>
210.....16576	<b>27 CFR</b>	90.....16123	111.....16786, 17076
230.....16576	<b>Proposed Rules:</b>	91.....16123	266.....17749
239.....16576	4.....15878	199.....16136	<b>40 CFR</b>
270.....16576	<b>28 CFR</b>	<b>Proposed Rules:</b>	9.....17154
274.....16576	36.....17442	77.....15673	16.....17485
<b>18 CFR</b>	522.....16406	91.....16157	51.....16690
141.....15333	540.....15812	989.....17061	52.....16139, 16140, 17696, 17697, 17698, 17700, 17703, 17706, 17708, 17933, 17936, 17938, 17940, 17942, 18300, 18307, 18310
161.....15336	545.....15812, 16406	<b>Proposed Rules:</b>	55.....17269
250.....15336	551.....16406	26.....16780	76.....17154
284.....16537	<b>Proposed Rules:</b>	110.....16580, 16783	80.....15625, 15629
<b>Proposed Rules:</b>	0.....15880	126.....16783	81.....17708, 18300
284.....15672, 15877	<b>29 CFR</b>	160.....16783	86.....16262
	1904.....15594, 16895	160.....16783	88.....16262
	1910.....15339, 16334, 17478	162.....16780	180.....15856, 16142, 17486, 17487, 17710
	1915.....17478		



271.....	15633, 16566, 16568, 16987, 16991, 17273
600.....	16262
721.....	17488, 17489, 17490, 17491
750.....	16991
761.....	16991
<b>Proposed Rules:</b>	
52.....	15863, 15686, 15689, 15691, 16158, 16580, 16582, 17078, 18341, 18346
63.....	15504
70.....	15504
81.....	16158
156.....	18058
165.....	15966
180.....	17508, 17751, 17754
185.....	17754
186.....	17754
261.....	17080, 18348
271.....	18348
302.....	18348
455.....	17860
763.....	17301
<b>41 CFR</b>	
Ch. 51.....	16777
101-38.....	15635
<b>42 CFR</b>	
405.....	18318
<b>Proposed Rules:</b>	
124.....	15693
<b>43 CFR</b>	
12.....	17711
3180.....	16999
<b>Public Land Orders:</b>	
7035.....	15636
7036.....	15342

<b>44 CFR</b>	
<b>Proposed Rules:</b>	
59.....	15351
60.....	15351
64.....	15351
65.....	15351, 17712, 17714, 17715, 17717
67.....	17718, 17719, 17721
70.....	15351
75.....	15351
<b>45 CFR</b>	
1180.....	15343
<b>Proposed Rules:</b>	
Ch. XXIV.....	16585
1160.....	16162
<b>46 CFR</b>	
30.....	16999
35.....	16778
40.....	16999
78.....	16778
97.....	16778
98.....	16999
147.....	16999
150.....	16999
151.....	16999
153.....	16999
171.....	17047
503.....	15636
<b>Proposed Rules:</b>	
38.....	16783
78.....	16783
97.....	16783, 17418
148.....	17418
194.....	16783
401.....	17303
403.....	17303
404.....	17303
540.....	18443
552.....	16592

<b>47 CFR</b>	
64.....	18318
76.....	17943, 17961, 17975
90.....	15857
<b>Proposed Rules:</b>	
64.....	18349
76.....	18064, 18066
<b>48 CFR</b>	
Ch. 1.....	17722
219.....	15501
226.....	15501
<b>Proposed Rules:</b>	
Ch. 19.....	18090
15.....	16388, 16389
19.....	16390
25.....	16391
28.....	16392
31.....	16393
44.....	16393
52.....	16389, 16390, 16391, 16392, 16393
225.....	17756
9903.....	15695
<b>49 CFR</b>	
19.....	15637
37.....	17442
190.....	17275
192.....	17275
193.....	17275
195.....	17275
533.....	16312
571.....	15858, 17992, 18320
<b>Proposed Rules:</b>	
107.....	15602
171.....	15602
533.....	16324
571.....	16788, 17324, 17325, 17326, 18090, 18091
572.....	18091

1312.....	16164
1314.....	16164

**50 CFR**

17.....	15345, 17994, 18324
216.....	15655, 16144
229.....	17048
285.....	17723
625.....	15863
651.....	15656, 15657
663.....	15345, 17491, 17726
672.....	17737, 17848
675.....	15346, 16570, 17738
<b>Proposed Rules:</b>	
15.....	15966
17.....	15361, 15366, 15696, 16792, 18350, 18353
20.....	16762
216.....	17082
261.....	18091
262.....	18091
263.....	18091
267.....	18091
301.....	15700
641.....	16611
644.....	15882
651.....	18092

**LIST OF PUBLIC LAWS**

Note: No public bills which have become law were received by the Office of the Federal Register for inclusion in today's List of Public Laws.

Last List April 14, 1994

## CFR CHECKLIST

This checklist, prepared by the Office of the Federal Register, is published weekly. It is arranged in the order of CFR titles, stock numbers, prices, and revision dates.

An asterisk (\*) precedes each entry that has been issued since last week and which is now available for sale at the Government Printing Office.

A checklist of current CFR volumes comprising a complete CFR set, also appears in the latest issue of the LSA (List of CFR Sections Affected), which is revised monthly.

The annual rate for subscription to all revised volumes is \$829.00 domestic, \$207.25 additional for foreign mailing.

Mail orders to the Superintendent of Documents, Attn: New Orders, P.O. Box 371954, Pittsburgh, PA 15250-7954. All orders must be accompanied by remittance (check, money order, GPO Deposit Account, VISA, or Master Card). Charge orders may be telephoned to the GPO Order Desk, Monday through Friday, at (202) 783-3238 from 8:00 a.m. to 4:00 p.m. eastern time, or FAX your charge orders to (202) 512-2233.

Title	Stock Number	Price	Revision Date
1, 2 (2 Reserved)	(869-022-00001-2)	\$5.00	Jan. 1, 1994
3 (1992 Compilation and Parts 100 and 101)	(869-019-00002-0)	17.00	Jan. 1, 1993
*4	(869-022-00003-9)	5.50	Jan. 1, 1994
5 Parts:			
1-699	(869-019-00004-6)	21.00	Jan. 1, 1993
700-1199	(869-019-00005-4)	17.00	Jan. 1, 1993
*1200-End, 6 (6 Reserved)	(869-022-00006-3)	23.00	Jan. 1, 1994
7 Parts:			
0-26	(869-019-00007-1)	20.00	Jan. 1, 1993
27-45	(869-019-00008-9)	13.00	Jan. 1, 1993
46-51	(869-022-00009-8)	20.00	Jan. 1, 1993
52	(869-019-00010-1)	28.00	Jan. 1, 1993
53-209	(869-019-00011-9)	21.00	Jan. 1, 1993
210-299	(869-019-00012-7)	30.00	Jan. 1, 1993
300-399	(869-019-00013-5)	15.00	Jan. 1, 1993
400-699	(869-019-00014-3)	17.00	Jan. 1, 1993
700-899	(869-019-00015-1)	21.00	Jan. 1, 1993
900-999	(869-019-00016-0)	33.00	Jan. 1, 1993
1000-1059	(869-019-00017-8)	20.00	Jan. 1, 1993
1060-1119	(869-019-00018-6)	13.00	Jan. 1, 1993
1120-1199	(869-019-00019-4)	11.00	Jan. 1, 1993
1200-1499	(869-019-00020-8)	27.00	Jan. 1, 1993
1500-1899	(869-019-00021-6)	17.00	Jan. 1, 1993
1900-1939	(869-019-00022-4)	13.00	Jan. 1, 1993
1940-1949	(869-019-00023-2)	27.00	Jan. 1, 1993
1950-1999	(869-019-00024-1)	32.00	Jan. 1, 1993
2000-End	(869-019-00025-9)	12.00	Jan. 1, 1993
8	(869-019-00026-7)	20.00	Jan. 1, 1993
9 Parts:			
1-199	(869-019-00027-5)	27.00	Jan. 1, 1993
200-End	(869-019-00028-3)	21.00	Jan. 1, 1993
10 Parts:			
0-50	(869-019-00029-1)	29.00	Jan. 1, 1993
51-199	(869-019-00030-5)	21.00	Jan. 1, 1993
200-399	(869-022-00031-4)	15.00	Jan. 1, 1993
400-499	(869-019-00032-1)	20.00	Jan. 1, 1993
500-End	(869-019-00033-0)	33.00	Jan. 1, 1993
11	(869-019-00034-8)	13.00	Jan. 1, 1993
12 Parts:			
*1-199	(869-022-00035-7)	12.00	Jan. 1, 1994
200-219	(869-019-00036-4)	15.00	Jan. 1, 1993
220-299	(869-019-00037-2)	26.00	Jan. 1, 1993
300-499	(869-019-00038-1)	21.00	Jan. 1, 1993
500-599	(869-019-00039-9)	19.00	Jan. 1, 1993
600-End	(869-019-00040-2)	28.00	Jan. 1, 1993
13	(869-019-00041-1)	28.00	Jan. 1, 1993

Title	Stock Number	Price	Revision Date
14 Parts:			
1-59	(869-019-00042-9)	29.00	Jan. 1, 1993
60-139	(869-019-00043-7)	26.00	Jan. 1, 1993
140-199	(869-019-00044-5)	12.00	Jan. 1, 1993
200-1199	(869-019-00045-3)	22.00	Jan. 1, 1993
1200-End	(869-019-00046-1)	16.00	Jan. 1, 1993
15 Parts:			
0-299	(869-019-00047-0)	14.00	Jan. 1, 1993
300-799	(869-019-00048-8)	25.00	Jan. 1, 1993
800-End	(869-019-00049-6)	19.00	Jan. 1, 1993
16 Parts:			
*0-149	(869-022-00050-1)	6.50	Jan. 1, 1994
150-999	(869-019-00051-8)	17.00	Jan. 1, 1993
1000-End	(869-019-00052-6)	24.00	Jan. 1, 1993
17 Parts:			
1-199	(869-019-00054-2)	18.00	Apr. 1, 1993
200-239	(869-019-00055-1)	23.00	June 1, 1993
240-End	(869-019-00056-9)	30.00	June 1, 1993
18 Parts:			
1-149	(869-019-00057-7)	16.00	Apr. 1, 1993
150-279	(869-019-00058-5)	19.00	Apr. 1, 1993
280-399	(869-019-00059-3)	15.00	Apr. 1, 1993
400-End	(869-019-00060-7)	10.00	Apr. 1, 1993
19 Parts:			
1-199	(869-019-00061-5)	35.00	Apr. 1, 1993
200-End	(869-019-00062-3)	11.00	Apr. 1, 1993
20 Parts:			
1-399	(869-019-00063-1)	19.00	Apr. 1, 1993
400-499	(869-019-00064-0)	31.00	Apr. 1, 1993
500-End	(869-019-00065-8)	30.00	Apr. 1, 1993
21 Parts:			
1-99	(869-019-00066-6)	15.00	Apr. 1, 1993
100-169	(869-019-00067-4)	21.00	Apr. 1, 1993
170-199	(869-019-00068-2)	20.00	Apr. 1, 1993
200-299	(869-019-00069-1)	6.00	Apr. 1, 1993
300-499	(869-019-00070-4)	34.00	Apr. 1, 1993
500-599	(869-019-00071-2)	21.00	Apr. 1, 1993
600-799	(869-019-00072-1)	8.00	Apr. 1, 1993
800-1299	(869-019-00073-9)	22.00	Apr. 1, 1993
1300-End	(869-019-00074-7)	12.00	Apr. 1, 1993
22 Parts:			
1-299	(869-019-00075-5)	30.00	Apr. 1, 1993
300-End	(869-019-00076-3)	22.00	Apr. 1, 1993
23	(869-019-00077-1)	21.00	Apr. 1, 1993
24 Parts:			
0-199	(869-019-00078-0)	38.00	Apr. 1, 1993
200-499	(869-019-00079-8)	36.00	Apr. 1, 1993
500-699	(869-019-00080-1)	17.00	Apr. 1, 1993
700-1699	(869-019-00081-0)	39.00	Apr. 1, 1993
1700-End	(869-019-00082-8)	15.00	Apr. 1, 1993
25	(869-019-00083-6)	31.00	Apr. 1, 1993
26 Parts:			
§§ 1.0-1-1.60	(869-019-00084-4)	21.00	Apr. 1, 1993
§§ 1.61-1.169	(869-019-00085-2)	37.00	Apr. 1, 1993
§§ 1.170-1.300	(869-019-00086-1)	23.00	Apr. 1, 1993
§§ 1.301-1.400	(869-019-00087-9)	21.00	Apr. 1, 1993
§§ 1.401-1.440	(869-019-00088-7)	31.00	Apr. 1, 1993
§§ 1.441-1.500	(869-019-00089-5)	23.00	Apr. 1, 1993
§§ 1.501-1.640	(869-019-00090-9)	20.00	Apr. 1, 1993
§§ 1.641-1.850	(869-019-00091-7)	24.00	Apr. 1, 1993
§§ 1.851-1.907	(869-019-00092-5)	27.00	Apr. 1, 1993
§§ 1.908-1.1000	(869-019-00093-3)	26.00	Apr. 1, 1993
§§ 1.1001-1.1400	(869-019-00094-1)	22.00	Apr. 1, 1993
§§ 1.1401-End	(869-019-00095-0)	31.00	Apr. 1, 1993
2-29	(869-019-00096-8)	23.00	Apr. 1, 1993
30-39	(869-019-00097-6)	18.00	Apr. 1, 1993
40-49	(869-019-00098-4)	13.00	Apr. 1, 1993
50-299	(869-019-00099-2)	13.00	Apr. 1, 1993
300-499	(869-017-00100-0)	23.00	Apr. 1, 1993
500-599	(869-019-00101-8)	6.00	Apr. 1, 1990

Title	Stock Number	Price	Revision Date	Title	Stock Number	Price	Revision Date
600-End	(869-019-00102-6)	8.00	Apr. 1, 1993	790-End	(869-019-00155-7)	26.00	July 1, 1993
<b>27 Parts:</b>				<b>41 Chapters:</b>			
1-199	(869-019-00103-4)	37.00	Apr. 1, 1993	1, 1-1 to 1-10		13.00	<sup>3</sup> July 1, 1984
200-End	(869-019-00104-2)	11.00	<sup>5</sup> Apr. 1, 1991	1, 1-11 to Appendix, 2 (2 Reserved)		13.00	<sup>3</sup> July 1, 1984
<b>28 Parts:</b>				3-6		14.00	<sup>3</sup> July 1, 1984
1-42	(869-019-00105-1)	27.00	July 1, 1993	7		6.00	<sup>3</sup> July 1, 1984
43-End	(869-019-00106-9)	21.00	July 1, 1993	8		4.50	<sup>3</sup> July 1, 1984
<b>29 Parts:</b>				9		13.00	<sup>3</sup> July 1, 1984
0-99	(869-019-00107-7)	21.00	July 1, 1993	10-17		9.50	<sup>3</sup> July 1, 1984
100-499	(869-019-00108-5)	9.50	July 1, 1993	18, Vol. I, Parts 1-5		13.00	<sup>3</sup> July 1, 1984
500-899	(869-019-00109-3)	36.00	July 1, 1993	18, Vol. II, Parts 6-19		13.00	<sup>3</sup> July 1, 1984
900-1899	(869-019-00110-7)	17.00	July 1, 1993	18, Vol. III, Parts 20-52		13.00	<sup>3</sup> July 1, 1984
1900-1910 (§§ 1901.1 to 1910.999)	(869-019-00111-5)	31.00	July 1, 1993	19-100		13.00	<sup>3</sup> July 1, 1984
1910 (§§ 1910.1000 to end)	(869-019-00112-3)	21.00	July 1, 1993	1-100	(869-019-00156-5)	10.00	July 1, 1993
1911-1925	(869-019-00113-1)	22.00	July 1, 1993	101	(869-019-00157-3)	30.00	July 1, 1993
1926	(869-019-00114-0)	33.00	July 1, 1993	102-200	(869-019-00158-1)	11.00	<sup>6</sup> July 1, 1991
1927-End	(869-019-00115-8)	36.00	July 1, 1993	201-End	(869-019-00159-0)	12.00	July 1, 1993
<b>30 Parts:</b>				<b>42 Parts:</b>			
1-199	(869-019-00116-6)	27.00	July 1, 1993	1-399	(869-019-00160-3)	24.00	Oct. 1, 1993
200-699	(869-019-00117-4)	20.00	July 1, 1993	*400-429	(869-019-00161-1)	25.00	Oct. 1, 1993
700-End	(869-019-00118-2)	27.00	July 1, 1993	430-End	(869-019-00162-0)	36.00	Oct. 1, 1993
<b>31 Parts:</b>				<b>43 Parts:</b>			
0-199	(869-019-00119-1)	18.00	July 1, 1993	1-999	(869-019-00163-8)	23.00	Oct. 1, 1993
200-End	(869-019-00120-4)	29.00	July 1, 1993	1000-3999	(869-019-00164-6)	32.00	Oct. 1, 1993
<b>32 Parts:</b>				4000-End	(869-019-00165-4)	14.00	Oct. 1, 1993
1-39, Vol. I		15.00	<sup>2</sup> July 1, 1984	44	(869-019-00166-2)	27.00	Oct. 1, 1993
1-39, Vol. II		19.00	<sup>2</sup> July 1, 1984	<b>45 Parts:</b>			
1-39, Vol. III		18.00	<sup>2</sup> July 1, 1984	1-199	(869-019-00167-1)	22.00	Oct. 1, 1993
1-190	(869-019-00121-2)	30.00	July 1, 1993	200-499	(869-019-00168-9)	15.00	Oct. 1, 1993
191-399	(869-019-00122-1)	36.00	July 1, 1993	500-1199	(869-019-00169-7)	30.00	Oct. 1, 1993
400-629	(869-019-00123-9)	26.00	July 1, 1993	1200-End	(869-019-00170-1)	22.00	Oct. 1, 1993
630-699	(869-019-00124-7)	14.00	<sup>6</sup> July 1, 1991	<b>46 Parts:</b>			
700-799	(869-019-00125-5)	21.00	July 1, 1993	1-40	(869-019-00171-9)	18.00	Oct. 1, 1993
800-End	(869-019-00126-3)	22.00	July 1, 1993	41-69	(869-019-00172-7)	16.00	Oct. 1, 1993
<b>33 Parts:</b>				70-89	(869-019-00173-5)	8.50	Oct. 1, 1993
1-124	(869-019-00127-1)	20.00	July 1, 1993	90-139	(869-019-00174-3)	15.00	Oct. 1, 1993
125-199	(869-019-00128-0)	25.00	July 1, 1993	140-155	(869-019-00175-1)	12.00	Oct. 1, 1993
200-End	(869-019-00129-8)	24.00	July 1, 1993	156-165	(869-019-00176-0)	17.00	Oct. 1, 1993
<b>34 Parts:</b>				166-199	(869-019-00177-8)	17.00	Oct. 1, 1993
1-299	(869-019-00130-1)	27.00	July 1, 1993	200-499	(869-019-00178-6)	20.00	Oct. 1, 1993
300-399	(869-019-00131-0)	20.00	July 1, 1993	500-End	(869-019-00179-4)	15.00	Oct. 1, 1993
400-End	(869-019-00132-8)	37.00	July 1, 1993	<b>47 Parts:</b>			
35	(869-019-00133-6)	12.00	July 1, 1993	0-19	(869-017-00177-5)	22.00	Oct. 1, 1992
<b>36 Parts:</b>				20-39	(869-019-00181-6)	24.00	Oct. 1, 1993
1-199	(869-019-00134-4)	16.00	July 1, 1993	40-69	(869-019-00182-4)	14.00	Oct. 1, 1993
200-End	(869-019-00135-2)	35.00	July 1, 1993	70-79	(869-019-00183-2)	23.00	Oct. 1, 1993
37	(869-019-00136-1)	20.00	July 1, 1993	80-End	(869-017-00181-3)	24.00	Oct. 1, 1992
<b>38 Parts:</b>				<b>48 Chapters:</b>			
0-17	(869-019-00137-9)	31.00	July 1, 1993	1 (Parts 1-51)	(869-019-00185-9)	36.00	Oct. 1, 1993
18-End	(869-019-00138-7)	30.00	July 1, 1993	1 (Parts 52-99)	(869-019-00186-7)	23.00	Oct. 1, 1993
39	(869-019-00139-5)	17.00	July 1, 1993	2 (Parts 201-251)	(869-019-00187-5)	16.00	Oct. 1, 1993
<b>40 Parts:</b>				2 (Parts 252-299)	(869-019-00188-3)	12.00	Oct. 1, 1993
1-51	(869-019-00140-9)	39.00	July 1, 1993	3-6	(869-019-00189-1)	23.00	Oct. 1, 1993
52	(869-019-00141-7)	37.00	July 1, 1993	7-14	(869-019-00190-5)	31.00	Oct. 1, 1993
53-59	(869-019-00142-5)	11.00	July 1, 1993	15-28	(869-019-00191-3)	31.00	Oct. 1, 1993
60	(869-019-00143-3)	35.00	July 1, 1993	29-End	(869-019-00192-1)	17.00	Oct. 1, 1993
61-80	(869-019-00144-1)	29.00	July 1, 1993	<b>49 Parts:</b>			
81-85	(869-019-00145-0)	21.00	July 1, 1993	1-99	(869-019-00193-0)	23.00	Oct. 1, 1993
86-99	(869-019-00146-8)	39.00	July 1, 1993	*100-177	(869-019-00194-8)	30.00	Oct. 1, 1993
100-149	(869-019-00147-6)	36.00	July 1, 1993	178-199	(869-019-00195-6)	20.00	Oct. 1, 1993
150-189	(869-019-00148-4)	24.00	July 1, 1993	200-399	(869-019-00196-4)	27.00	Oct. 1, 1993
190-259	(869-019-00149-2)	17.00	July 1, 1993	400-999	(869-017-00194-5)	31.00	Oct. 1, 1992
260-299	(869-019-00150-6)	39.00	July 1, 1993	1000-1199	(869-019-00198-1)	18.00	Oct. 1, 1993
300-399	(869-019-00151-4)	18.00	July 1, 1993	1200-End	(869-019-00199-9)	22.00	Oct. 1, 1993
400-424	(869-019-00152-2)	27.00	July 1, 1993	<b>50 Parts:</b>			
425-699	(869-019-00153-1)	28.00	July 1, 1993	1-199	(869-019-00200-6)	20.00	Oct. 1, 1993
700-789	(869-019-00154-9)	26.00	July 1, 1993	200-599	(869-017-00198-8)	20.00	Oct. 1, 1992
				*600-End	(869-019-00202-2)	22.00	Oct. 1, 1993
				<b>CFR Index and Findings</b>			
				Aids	(869-019-00053-4)	36.00	Jan. 1, 1993

Title	Stock Number	Price	Revision Date
Complete 1994 CFR set .....		829.00	1994
Microfiche CFR Edition:			
Complete set (one-time mailing) .....		188.00	1991
Complete set (one-time mailing) .....		188.00	1992
Complete set (one-time mailing) .....		223.00	1993
Subscription (mailed as issued) .....		244.00	1994
Individual copies .....		2.00	1994

<sup>1</sup>Because Title 3 is an annual compilation, this volume and all previous volumes should be retained as a permanent reference source.

<sup>2</sup>The July 1, 1985 edition of 32 CFR Parts 1-189 contains a note only for Parts 1-39 inclusive. For the full text of the Defense Acquisition Regulations in Parts 1-39, consult the three CFR volumes issued as of July 1, 1984, containing those parts.

<sup>3</sup>The July 1, 1985 edition of 41 CFR Chapters 1-100 contains a note only for Chapters 1 to 49 inclusive. For the full text of procurement regulations in Chapters 1 to 49, consult the eleven CFR volumes issued as of July 1, 1984 containing those chapters.

<sup>4</sup>No amendments to this volume were promulgated during the period Apr. 1, 1990 to Mar. 31, 1993. The CFR volume issued April 1, 1990, should be retained.

<sup>5</sup>No amendments to this volume were promulgated during the period Apr. 1, 1991 to Mar. 31, 1993. The CFR volume issued April 1, 1991, should be retained.

<sup>6</sup>No amendments to this volume were promulgated during the period July 1, 1991 to June 30, 1993. The CFR volume issued July 1, 1991, should be retained.

<sup>7</sup>No amendments to this volume were promulgated during the period January 1, 1993 to December 31, 1993. The CFR volume issued January 1, 1993, should be retained.





The authentic text behind the news . . .

# The Weekly Compilation of Presidential Documents

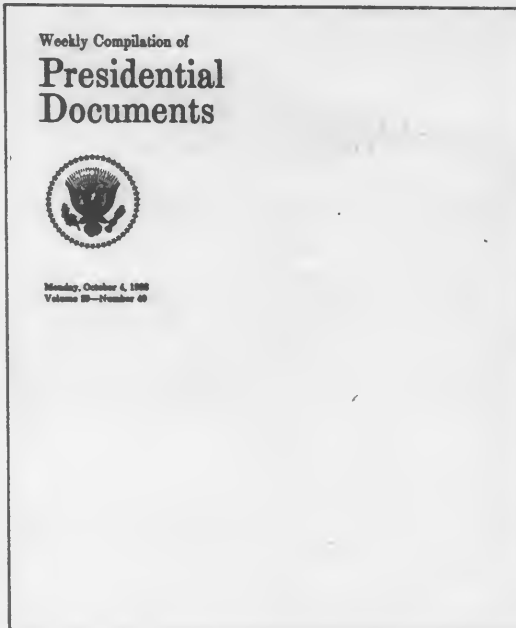

This unique service provides up-to-date information on Presidential policies and announcements. It contains the full text of the President's public speeches, statements, messages to Congress, news conferences, and other Presidential materials released by the White House.

The Weekly Compilation carries a

Monday dateline and covers materials released during the preceding week. Each issue contains an Index of Contents and a Cumulative Index to Prior Issues.

Separate indexes are published periodically. Other features include lists of acts approved by the President, nominations submitted to

the Senate, a checklist of White House press releases, and a digest of other Presidential activities and White House announcements.

Published by the Office of the Federal Register, National Archives and Records Administration.

## Superintendent of Documents Subscription Order Form

Order Processing Code:

\* 5420

Charge your order.  
It's easy!



To fax your orders (202) 512-2233

**YES**, please enter \_\_\_\_\_ one year subscriptions for the **Weekly Compilation of Presidential Documents (PD)** so I can keep up to date on Presidential activities.

\$103 First Class Mail

\$65 Regular Mail

The total cost of my order is \$ \_\_\_\_\_. Price includes regular domestic postage and handling and is subject to change. International customers please add 25%.

\_\_\_\_\_  
(Company or personal name) (Please type or print)

\_\_\_\_\_  
(Additional address/attention line)

\_\_\_\_\_  
(Street address)

\_\_\_\_\_  
(City, State, Zip code)

\_\_\_\_\_  
(Daytime phone including area code)

\_\_\_\_\_  
(Purchase order no.)

**For privacy, check box below:**

Do not make my name available to other mailers

**Check method of payment:**

Check payable to Superintendent of Documents

GPO Deposit Account  -

VISA  MasterCard  (expiration)

\_\_\_\_\_  
(Authorizing signature)

1/94

**Thank you for your order!**

Mail to: Superintendent of Documents  
P.O. Box 371954, Pittsburgh, PA 15250-7954





## Would you like to know...

if any changes have been made to the Code of Federal Regulations or what documents have been published in the Federal Register without reading the Federal Register every day? If so, you may wish to subscribe to the *LSA (List of CFR Sections Affected)*, the *Federal Register Index*, or both.

### LSA • List of CFR Sections Affected

The LSA (List of CFR Sections Affected) is designed to lead users of the Code of Federal Regulations to amendatory actions published in the Federal Register. The LSA is issued monthly in cumulative form. Entries indicate the nature of the changes—such as revised, removed, or corrected. \$24.00 per year.

### Federal Register Index

The index, covering the contents of the daily Federal Register, is issued monthly in cumulative form. Entries are carried primarily under the names of the issuing agencies. Significant subjects are carried as cross-references. \$22.00 per year.

A finding aid is included in each publication which lists Federal Register page numbers with the date of publication in the Federal Register

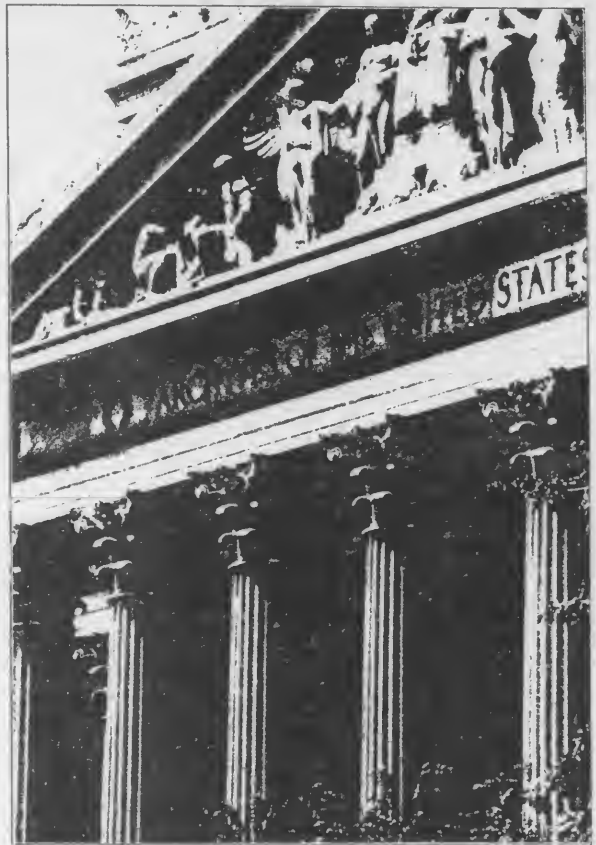

## Superintendent of Documents Subscription Order Form

Order Processing Code:

\* 5421

Charge your order.  
It's easy!



To fax your orders (202) 512-2233

**YES**, enter the following indicated subscriptions for one year:

**LSA • List of CFR Sections Affected (LCS)** at \$24 each

**Federal Register Index (FRSU)** at \$22 each

The total cost of my order is \$ \_\_\_\_\_. Price includes regular domestic postage and handling and is subject to change. International customers please add 25%.

\_\_\_\_\_  
(Company or personal name) (Please type or print)

\_\_\_\_\_  
(Additional address/attention line)

\_\_\_\_\_  
(Street address)

\_\_\_\_\_  
(City, State, Zip code)

\_\_\_\_\_  
(Daytime phone including area code)

\_\_\_\_\_  
(Purchase order no.)

### For privacy, check box below:

Do not make my name available to other mailers

### Check method of payment:

Check payable to Superintendent of Documents

GPO Deposit Account  \_\_\_\_\_ -

VISA  MasterCard  \_\_\_\_\_ (expiration)

\_\_\_\_\_

\_\_\_\_\_  
(Authorizing signature)

1/94

**Thank you for your order!**

Mail to: Superintendent of Documents  
P.O. Box 371954, Pittsburgh, PA 15250-7954

**INFORMATION ABOUT THE SUPERINTENDENT OF DOCUMENTS' SUBSCRIPTION SERVICE**

Know when to expect your renewal notice and keep a good thing coming. To keep our subscription prices down, the Government Printing Office mails each subscriber *only one renewal notice*. You can learn when you will get your renewal notice by checking the number that follows month/year code on the top line of your label as shown in this example:

A renewal notice will be sent approximately 90 days before this date.

A renewal notice will be sent approximately 90 days before this date.

...../.....  
 AFR SMITH212J DEC94 R 1  
 JOHN SMITH  
 212 MAIN STREET  
 FORESTVILLE MD 20747  
 .....

...../.....  
 AFRDO SMITH212J DEC94 R 1  
 JOHN SMITH  
 212 MAIN STREET  
 FORESTVILLE MD 20747  
 .....

To be sure that your service continues without interruption, please return your renewal notice promptly. If your subscription service is discontinued, simply send your mailing label from any issue to the Superintendent of Documents, Washington, DC 20402-9372 with the proper remittance. Your service will be reinstated.

**To change your address:** Please SEND YOUR MAILING LABEL, along with your new address to the Superintendent of Documents, Attn: Chief, Mail List Branch, Mail Stop: SSOM, Washington, DC 20402-9373.

**To inquire about your subscription service:** Please SEND YOUR MAILING LABEL, along with your correspondence, to the Superintendent of Documents, Attn: Chief, Mail List Branch, Mail Stop: SSOM, Washington, DC 20402-9375.

**To order a new subscription:** Please use the order form provided below.

Order Processing Code:  
 \* 5468

Superintendent of Documents Subscription Order Form

Charge your order.  
 It's easy!



To fax your orders (202) 512-2233

**YES**, please enter my subscriptions as follows:

\_\_\_\_\_ subscriptions to Federal Register (FR); including the daily Federal Register, monthly Index and LSA List of Code of Federal Regulations Sections Affected, at \$490 (\$612.50 foreign) each per year.

\_\_\_\_\_ subscriptions to Federal Register, *daily only* (FRDO), at \$444 (\$555 foreign) each per year.

The total cost of my order is \$\_\_\_\_\_. (Includes regular shipping and handling.) Price subject to change.

\_\_\_\_\_  
 Company or personal name (Please type or print)

\_\_\_\_\_  
 Additional address/attention line

\_\_\_\_\_  
 Street address

\_\_\_\_\_  
 City, State, Zip code

\_\_\_\_\_  
 Daytime phone including area code

\_\_\_\_\_  
 Purchase order number (optional)

For privacy, check box below:

Do not make my name available to other mailers

**Check method of payment:**

Check payable to Superintendent of Documents

GPO Deposit Account  -

VISA  MasterCard  (expiration date)

*Thank you for your order!*

\_\_\_\_\_  
 Authorizing signature 1/94

Mail To: Superintendent of Documents  
 P.O. Box 371954, Pittsburgh, PA 15250-7954

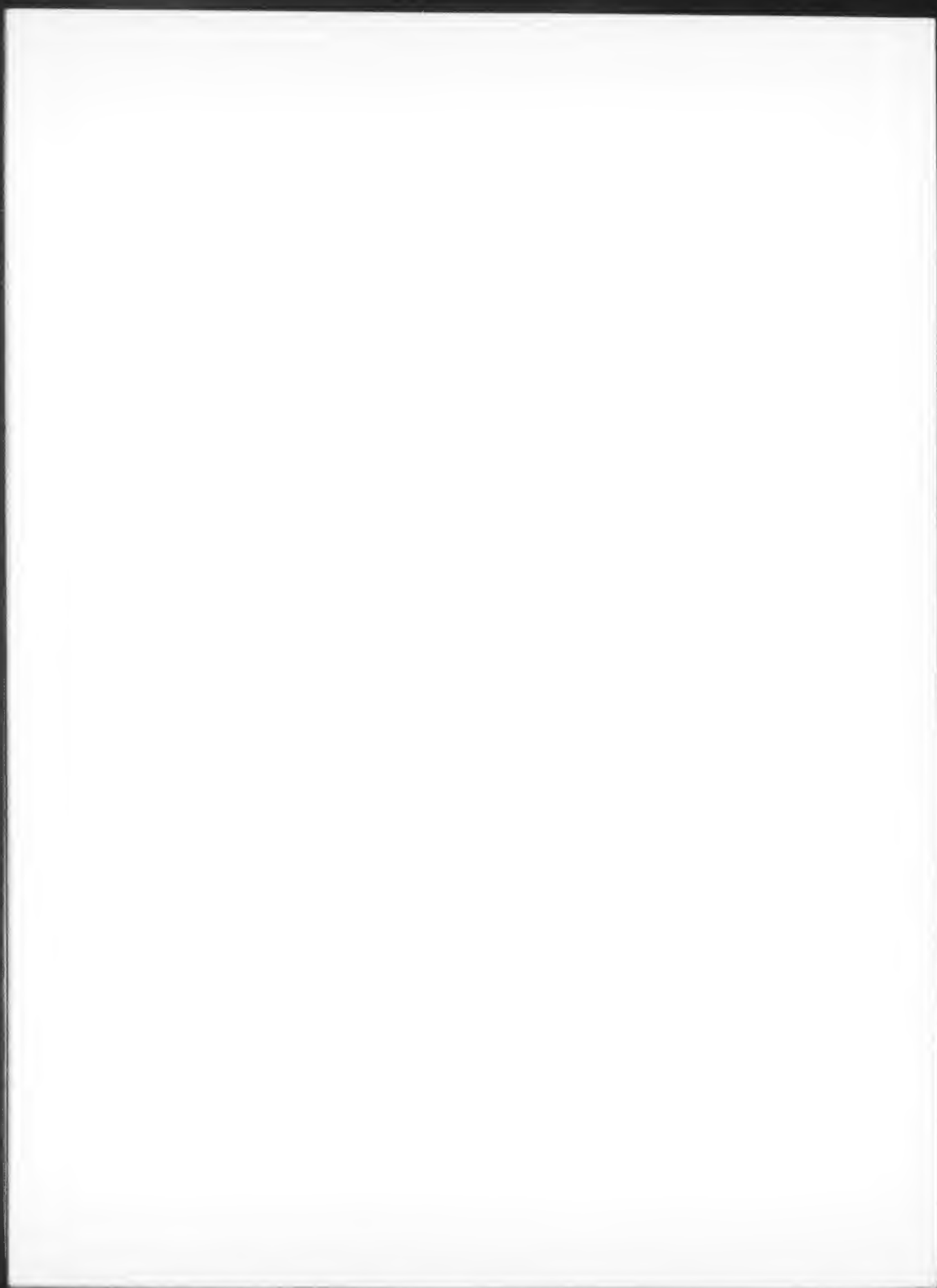



Printed on recycled paper

