

**CRANE, WHEEL MOUNTED; 20-TON AT  
10 FT-RADIUS, 2 ENGINES, DIESEL ENGINE DRIVEN,  
4 x 4, AIR TRANSPORTABLE, 3 PHASE W/BLADE,  
BULLDOZER, EARTH W/BLOCK, TACKLE, 20-TON  
W/BOOM, CRANE 30 FT (AMERICAN HOIST AND  
DERRICK MODEL 2380) (NSN 3810-00-763-7728) AND  
(MODEL 2385) (NSN 3810-00-043-5354)**

Reference: TM 5-3810-232-12, AND FEDERAL SUPPLY CATALOG C9100-IL.

Intervals (on-condition or hard time) and the related man-hour times are based on normal operation. The man-hour time specified is the time you need to do all the services prescribed for a particular interval. On condition (OC) oil sample intervals shall be applied unless changed by the Army Oil Analysis Program (AOAP) laboratory. Change the hard time interval if your lubricants are contaminated or if you are operating the equipment under adverse operating conditions, including longer-than-usual operating hours. The hard time interval may be extended during periods of low activity. If extended, adequate preservation precautions must be taken. Hard time intervals will be applied in the event AOAP laboratory support is not available.

**WARNING**

**Dry cleaning fluid is flammable. Do not use near a flame or excessive heat. Use only with adequate ventilation. Avoid prolonged breathing of vapors and minimize skin contact.**

Clean parts or fittings with dry cleaning solvent (SD), Type II or equivalent. Dry before lubricating. Dotted arrow shafts indicate lubrication on both sides of equipment. A dotted circle indicates a drain below. Relubricate all items found contaminated after fording or washing.

The lowest level of maintenance authorized to lubricate a point is indicated by one of the following symbols as appropriate: Operator/Crew (C) ; and Organizational Maintenance (O).

**Reporting errors and recommending improvements.** You can help improve this manual. If you find any mistakes or if you know of a way to improve the procedures, please let us know. Mail your letter or DA Form 2028 (Recommended Changes to Publications and Blank Forms) direct to: Commander, US Army Tank-Automotive Command, ATTN: DRSTA-MB, Warren, MI 48090. A reply will be furnished to you.

\*The time specified is the time required to perform all services at the particular interval (on-condition or hard times).

*TOTAL MAN-HOURS		*TOTAL MAN-HOURS		
INTERVAL	MAN-HOURS	INTERVAL	MAN-HOURS	
5	0.5	250	2.4	
10	1.9	300	1.6	
50	1.0	500	0.6	
100	1.5	1000	1.8	
200	0.8	2000	0.1	TA221952

**LUBRICANT • INTERVAL**

**INTERVAL • LUBRICANT**

- Steering Shaft Universal Joint (0)
- Transmission Gear Linkage (0)
- Air Cleaner Oil-Bath (C) (Model 2380) (See Key and Note 8)
- Front Differential Fill and Level (C) (Check level) (See Key)
- Front Differential Drain (0) (Drain and refill) (See Note 13)
- Engine Oil Filter (0) (See Notes 1 and 6)
- Crankcase Breather (0) (Clean and re-oil)

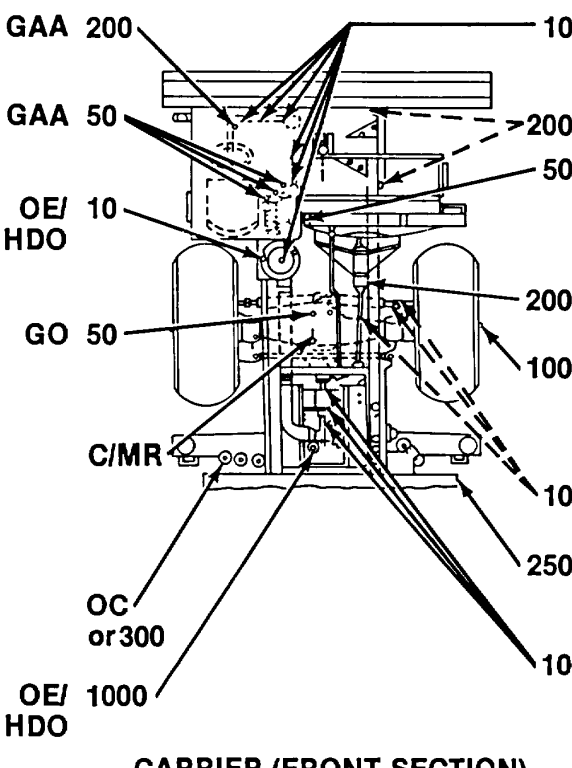

- 10 GAA Front Steering Linkage (0) (6 fittings)
- 200 GAA Blade Arm Lower (0)
- 50 GAA Transmission Directional Control Linkage (0) (Model 2380 only)
- 200 GAA Fan Hub (0) (Model 2380 only)
- 100 GO Wheel Planetaries Fill, Level, and Drain Plug(C) (Check level) (See Key)(See Note 15)
- 10 GAA Steering Cylinder Yoke (0)
- 250 Hydraulic Oil Filter (0) (Replace element) (See Note 11)
- 10 GAA Drive Shaft Transmission to Front Axle and Carrier Bearing (0) (See Note 16)

**CARRIER (FRONT SECTION)**

- Blade Ram Pivot (0)
- Steering Gear Box (Lubricate at time of overhaul)
- Steering Ball Joint (0) (5 fittings)
- Breather (Maintenance not required)
- Front Cradle Bushings (0)
- Crankcase Oil Drain Plug (0) (Drain and refill) (See Notes 1 and 5)
- Crankcase Oil Level Gage (C) (Check level) (See Note 4)
- CAUTION:** When OEA oil is used the level will be checked more often.

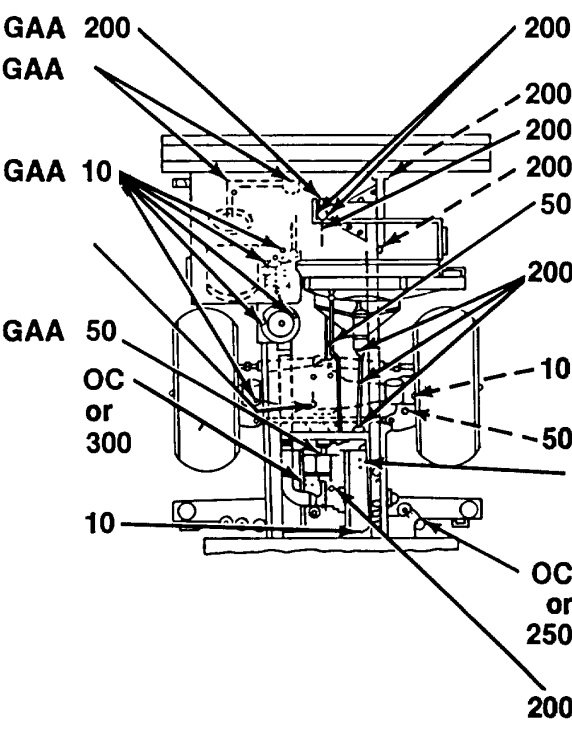

- 200 GAA Blade Cylinder Pivot (0) (2 fittings)
- 200 GAA Blade Arm Lower (0)
- 200 GAA Blade Latch Cable (0)
- 200 GAA Blade Arm Upper (0)
- 50 GAA Front Cradle Bushings (0)
- 200 GAA Fan Drive Shaft (0) (3 fittings) (Model 2380 only)
- 10 GAA Steering Knuckle (0) (Upper and lower front)
- 50 GAA Brake Camshaft (0)
- OE/HDO Crankcase Oil Fill Cap (C) (See Key)
- OC or 250 Torque Converter Transmission Oil Filters (0) (See Notes 1 and 7)
- 200 GAA Engine Tachometer Adapter (0)

**CARRIER (FRONT SECTION)**

TA221953

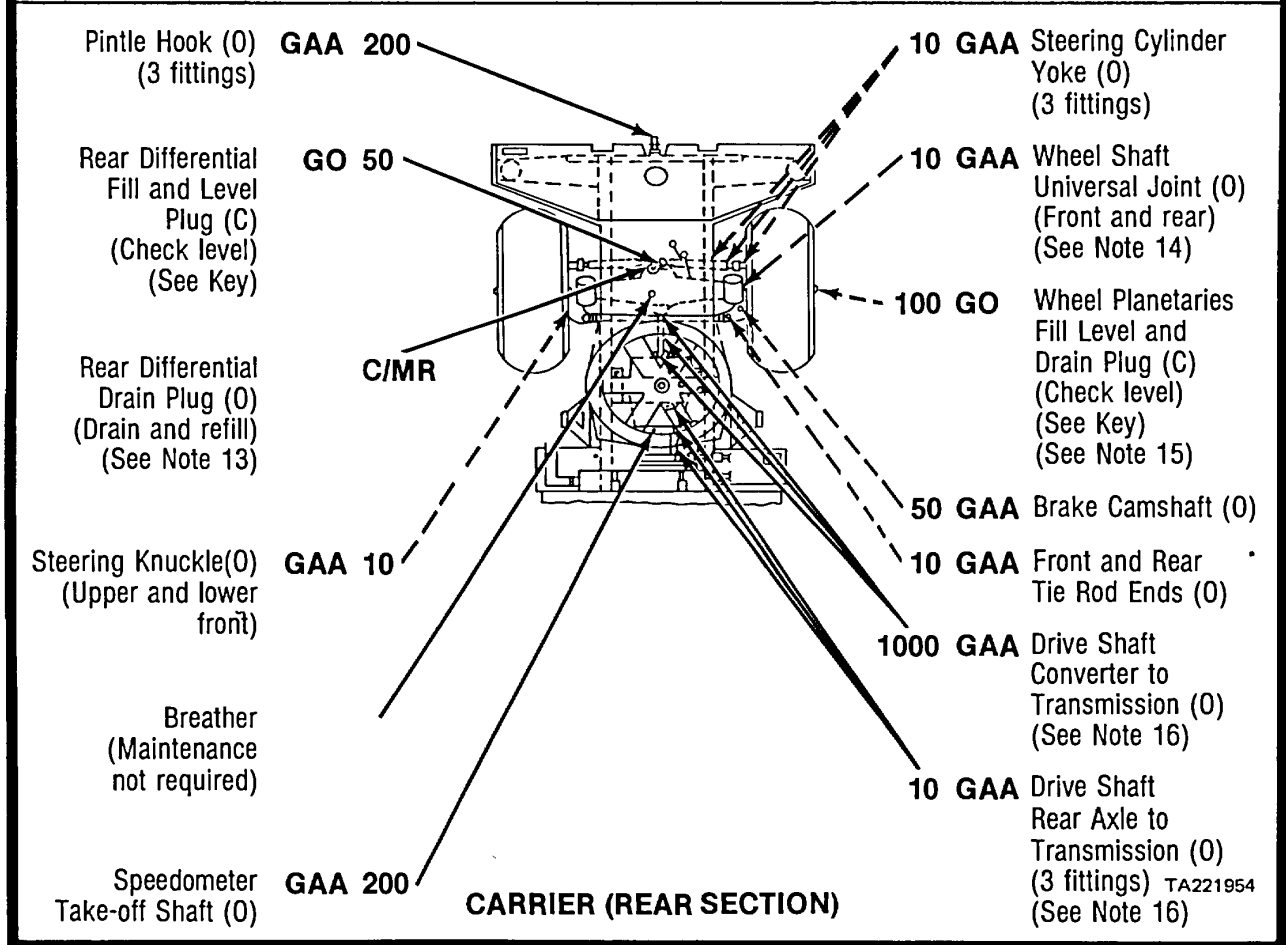
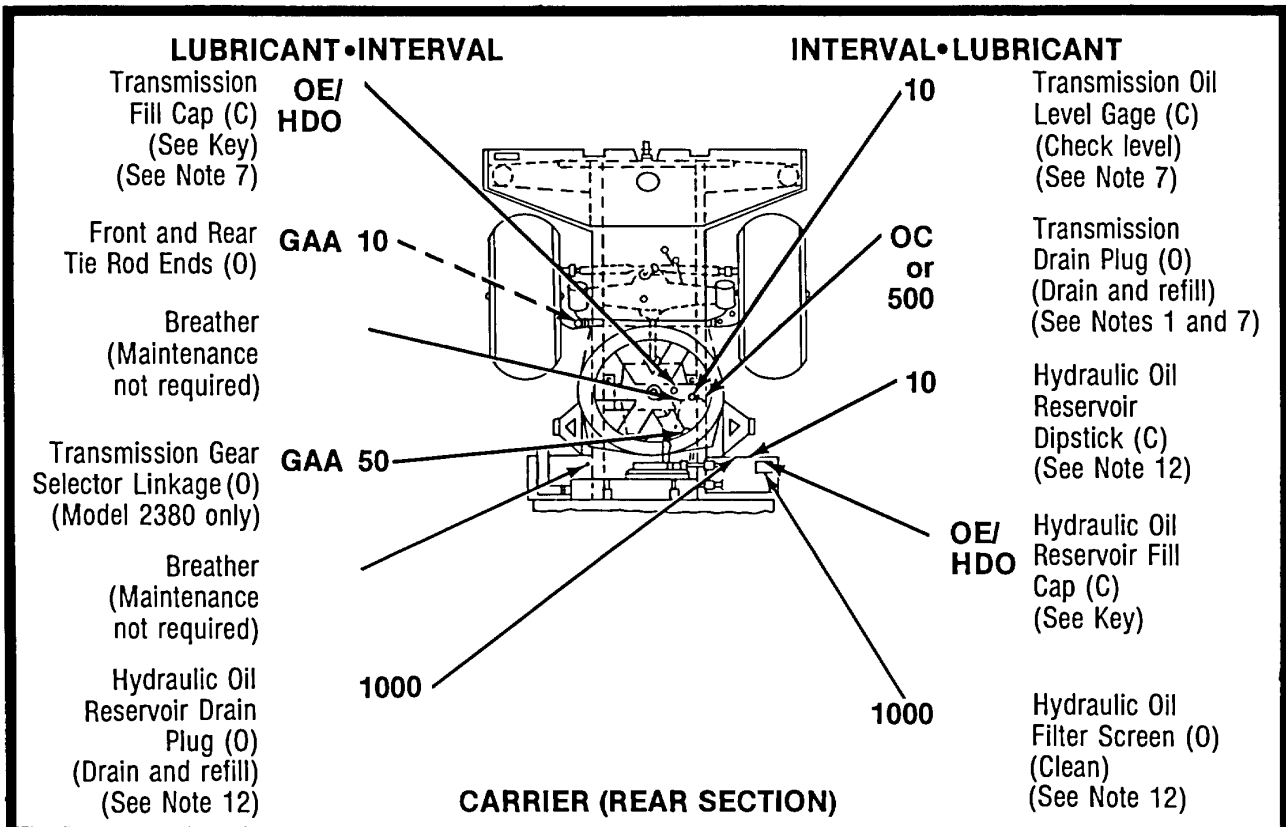

**LUBRICANT•INTERVAL**

**INTERVAL•LUBRICANT**

- Clutch Master Cylinder Fill and Level (C) (See Key) (Check level, fill to 1/4 inch from top) **BFS 50**
- Hoist Control Levers (O) **GAA 50**
- Bull Gear (C) (Lubricate thru opening in deck) (See Note 17) (See Key) **CW 50**
- Master Clutch Lever (O) **GAA 50**
- Boom Hoist Lever (O) **GAA 50**
- Horizontal Reversing Shaft Sprag Clutch Fill and Level Plug (C) (Check Level)(See Key) **OAI 50**
- Boom Hoist Chain (O) (Clean and coat) **OE/ HDO 10**
- Boom Hoist Bellcrank (O) **GAA 50**
- Master Clutch Bellcrank (O) **GAA 50**

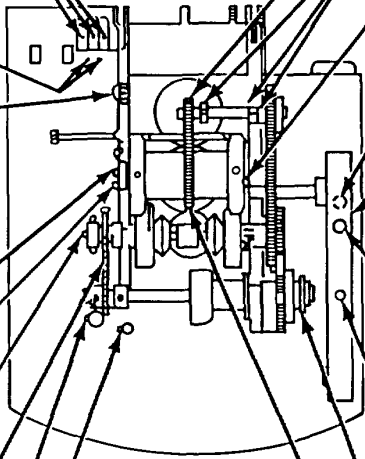

- 10 OE/ HDO** Chain (O) (Clean and coat)
- 500 GAA** Auxiliary Shaft (O) (Bearings) (3 fittings)
- 50 GAA** Counter Shaft Bearings (O)
- 250** Power Transfer Chaincase Drain Plug (O) (Drain and refill)
- 50** Power Transfer Chaincase Sight Glass (C) (Check level) (Model 2380 only)
- 50 OE/ HDO** Power Transfer Chaincase Fill and Level Plug (C) (Check level) (See Key) (Model 2385 only)
- 250 OE/ HDO** Power Transfer Chaincase Fill and Breather (O) (Clean and re-oil) (Model 2380 only)
- 10 GAA** Boom Hoist Shifting Collar and Lever (O) (3 fittings)
- 10 CW** Exposed Gears (O) (See Note 17)(See Key)

**MACHINERY DECK**

- Vertical Shaft Bushing (O) **GAA 10**
- Vertical Swing Shaft Upper Bushing (O) **GAA 10**
- Vertical Swing Shaft Lower Bushing (O) **GAA 10**
- Throttle Push-Pull Cable (O) (Oil can point) **OE/ HDO 100**
- Hydraulic Reservoir Fill and Level (C) (Check level)(See Key) (Model 2385 only) **BFS 50**
- Boom Hoist Jaw Clutch (O) **GAA 50**
- Boom Hoist Bearings (O) **GAA 50**

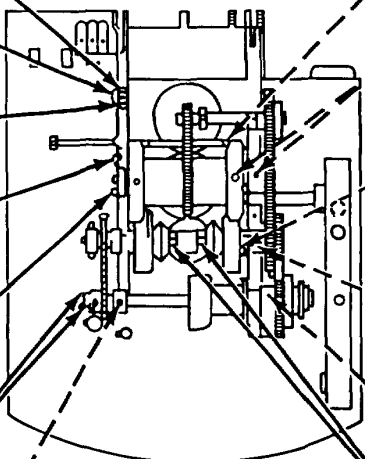

- 50 GAA** Hoist Drum Brake Shaft Bushings (O)
- 500 GAA** Hoist Drum Shaft Bearings (O)
- 10 GAA** Horizontal Reversing Shaft Shifting Collars (O)
- 500 GAA** Horizontal Reversing Shaft Bearings (O)
- 50 GAA** Boom Hoist Gear Bearings (O)
- 2000 GAA** Horizontal Reversing Shaft Bevel Gear Bearings (O)

**MACHINERY DECK**

TA221955

**LUBRICANT • INTERVAL**

**INTERVAL • LUBRICANT**

- Crankcase Breather (O)  
(Remove, clean re-oil and install)
- Engine Oil Filters (O)  
(See Notes 1 and 6)
- Crankcase Oil Level Gage (C)  
(Check level)  
(See Note 4)
- CAUTION:** When OEA oil is used, the level will be checked more often.
- Crankcase Oil Fill (C)  
(See Key)
- Crankcase Oil Drain Plug (O)  
(Drain and refill)  
(See Notes 1 and 5)
- Air Cleaner Oil-Bath (C)  
(See Key and Note 9)

- OE/ HDO 100
- OC or 300
- 10
- OE/ HDO
- OC or 300
- OE/ HDO 10

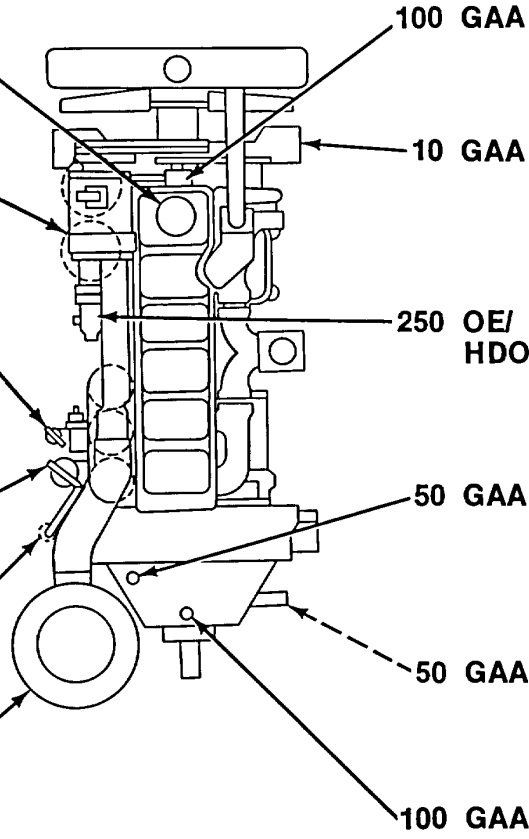

**CRANE ENGINE**

- 100 GAA Fan Pulley (O)  
(See Note 10)
- 10 GAA Water Pump Bearing (O)  
(Springly)
- 250 OE/ HDO Throttle Push-Pull Cable (O)  
(Oil can point)
- 50 GAA Clutch Throwout Bearing (O)  
(Springly)
- 50 GAA Clutch Throwout Shaft (O)
- 100 GAA Clutch Shaft Bearing (O)  
(Springly)

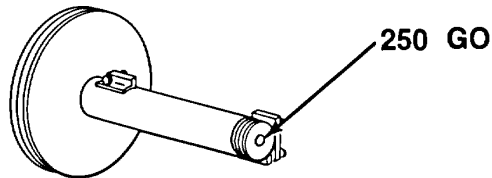

**TAGLINE UNIT**

- 250 GO Tagline Fill and Level Plug (C)  
(Check level)  
(See Key)  
(See Note 18)

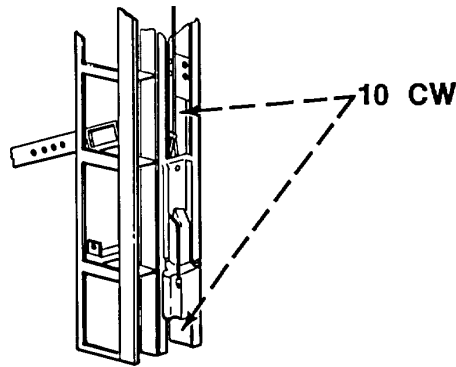

**PILEDRIVER**

- 10 CW Hammer Leads (O)  
(Clean and coat)  
(See Key)

TA221956

LUBRICANT•INTERVAL

INTERVAL•LUBRICANT

Dumping Sheave Bushing (0)

GAA 5

50 OE/ HDO Cables (0) (Clean and coat) (See Note 19)

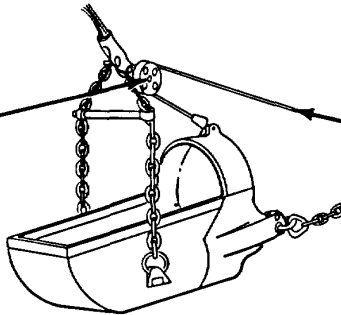

DRAG LINE BUCKET

Head Pulley Bushing (0)

GAA 5

5 GAA Guide Roller Cable Head Pulley Bushing (0) (4 fittings)

Closing Pulley Bushing (0)

GAA 5

10 GAA Closing Cable Anchor Pin (0)

Closing Pivot (0)

GAA 5

Brace Arm Bushings (0) (4 fittings)

GAA 5

CLAMSHELL BUCKET

Sheave Bushings (0)

GAA 5

5 GAA Guide Roller Bushing (0)

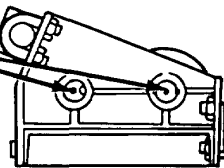

DRAG LINE FAIRLEAD

Jib Strut Sheave (0)

GAA 10

10 GAA Boom Point Sheaves (0) (3 fittings)

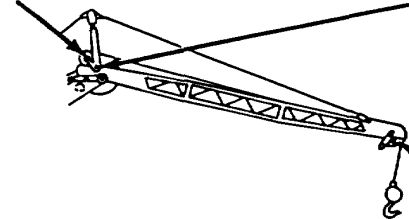

10 GAA Jib Point Sheave (0)

JIB BOOM

TA221957

**LUBRICANT • INTERVAL**

**INTERVAL • LUBRICANT**

Vertical Crossover Sheave Bushings (0) (2 fittings each side)

GAA 10

10 GAA

Horizontal Crossover Sheave Bushing (0)

Boom Point Sheaves (0) (3 fittings)

GAA 10

10 GAA

Bridle Anchor Bearings (0)

Guide Roller Bushings (0) (Oil can point)

OE/ HDO 10

10 GAA

Vertical Gantry Sheave Bushings (0) (3 fittings)

Boom Foot Bushings (0)

GAA 10

10 GAA

Bridle Sheave Bushings (0)

50 OE/ HDO

Cables (0) (Clean and coat) (See Note 19)

**BOOM AND GANTRY**

Control Levers and Brake Pedal Bushings (0)

GAA 50

5 GAA

Front Load Roller Bushings (0)

Hoist Drum Brake Shaft Bushings (0)

GAA 50

5 GAA

Rear Load Roller Bushings (0)

Boom Hoist Control Bellcrank (0)

GAA 50

10 GAA

Vertical Reversing Shaft Bearing (0)

Swing Control Bellcrank (0)

GAA 50

**CONTROL AND ROLLERS**

Sheave Bushing (0)

GAA 10

10 GAA

Swivel (0)

**HOOK BLOCK**

TA221958

\*KEY -

LUBRICANTS	CAPACITY	EXPECTED TEMPERATURES			INTERVALS
		Above + 15°F (Above -9°C)	+40° to -15°F (+4° to -26°C)	+40° to -65°F (+4° to -54°C)	
<b>OE/HDO</b> - Lubricating Oil, Internal Combustion Engine, Tactical Service  <b>OEA</b> - Lubricating Oil, Internal Combustion, Arctic  - Carrier Engine Crankcase  - Crane Engine Crankcase  - Power Transfer Chain Case Model 2380  - Power Transfer Chain Case Model 2385  - Oil Can Points (See Note 3)	22 qts. (20.8 L)  21 qts. (19.8 L)  3 qts. (2.8 L)  4 qts. (3.7 L)	<b>OE/HDO 30</b>	<b>OE/HDO 10</b>	<b>OEA</b> (See Note 2)	C/MR - Condition Monitor  OC - On Condition (AOAP)  Intervals given are in hours of normal operation.  For Arctic operation refer to FM 9-207
- Crane Engine Air Cleaner  - Carrier Engine Air Cleaner  - Transmission  - Hydraulic System Model 2380  Model 2385	2 qts. (1.9 L)  5 qts. (4.7 L)  26 qts. (24.6 L)  51 gal. (193 L) 36 gal. (126 L)				

\*See Note 20 for lubricant specification number.

TA221959



**\*KEY -**

		CAPACITY	EXPECTED TEMPERATURES			INTERVALS
			Above + 15°F (Above -9°C)	+40° to -15°F (+4° to -26°C)	+40° to -65°F (+4° to -54°C)	
<b>GO</b>	- Lubricating Oil, Gear,		<b>GO 80W/90</b>	<b>GO 80W/90</b>	<b>GO 75W</b>	C/MR - Condition Monitor  OC - On Condition (AOAP)  Intervals given are in hours of normal operation.
	Multipurpose					
	- Front Differential	22 qts. (20.8 L)				
	- Rear Differential	22 qts. (20.8 L)				
	- Wheel Planetaries	8 qts. (7.6 L)				
	- Tagline	4 qts. (3.7 L)				
<b>OAI</b>	- Lubricating Oil, Instruments		ALL TEMPERATURES			For Arctic operation refer to FM 9-207
	- Reversing Shaft Sprag Clutch	2 oz. (0.059 L)				
<b>CW</b>	- Lubricating Oil, Chain, Wire Rope, Exposed Gear		<b>CW-IIB</b>	<b>CW-IIB</b>	<b>CW-IIB</b>	
<b>BFS</b>	- Brake Fluid, Silicone, Automotive		ALL TEMPERATURES			
	- Clutch Master Cylinder					
	- Hydraulic Reservoir Model 2385					
<b>GAA</b>	- Grease, Automotive and Artillery		ALL TEMPERATURES			

\*See Note 20 for lubricant specification number.

TA221960

## NOTES:

1. ARMY OIL ANALYSIS PROGRAM (AOAP). For Active Army units, obtain samples from engine and automatic transmission every 50 hours of operation or 60 days (whichever comes first).

Reserve and National Guard activities will use 50 hours or 120 days as the prescribed sample intervals. Reserve and National Guard equipment in frequent use during active training period will adhere to the schedule for Active Army units. As a minimum, one sample from each unit's two week active training period will be submitted for each item of equipment. Send these samples to the nearest AOAP laboratory. Refer to TB 43-0210 for sampling instructions. When or if AOAP laboratory support is unavailable, hard time intervals will apply.

### NOTE

- **Do not hold oil samples. Submit oil samples as soon as they have been taken.**
- **Seasonal oil changes will be made due to expected temperatures. (See Key.)**

2. FOR OPERATION OF EQUIPMENT in PROTRACTED COLD TEMPERATURES BELOW -15°F (-26°C). Remove lubricants prescribed in Key for temperatures above -15°F (-26°C). Relubricate with lubricants specified in Key for temperatures below -15°F (-26°C). If OEA lubricant is required to meet the temperature ranges prescribed in the Key, OEA lubricant is to be used in place of OE/HDO-10 lubricant for all temperature ranges where OE/HDO-10 is specified in the Key.

3. OIL CAN POINTS. Each 50 hours lubricate throttle and governor linkage, control linkage, clutch pedal linkages, transmission shift linkage, counterweight lowering roller, latches, hinges, pins, clevises, and all exposed adjusting threads with OE/HDO.

4. CRANKCASE OIL LEVEL HOT OR COLD CHECK (CARRIER AND CRANE). Cold engine, oil level should be at high mark on dipstick. Hot engine, oil level must be between high and low marks on dipstick (allow to set 5 minutes before checking).

5. CRANKCASE OIL (CARRIER AND CRANE). Oil is to be changed each time an engine oil change is directed by AOAP laboratory. When AOAP laboratory support is not available, change oil each 300 hours. Drain when lubricant is warm.

6. ENGINE OIL FILTER (CARRIER AND CRANE). Filter element is to be replaced each time an engine oil change is directed by AOAP laboratory. After installing new filter element, fill crankcase, operate engine 5 minutes, check housing for leaks, check crankcase oil level and bring to full mark. When AOAP laboratory support is not available, install new filter element each 300 hours.

7. TRANSMISSION AND TRANSMISSION OIL FILTER (MODEL 2380). Check level each 10 hours with engine running at 500-600 RPM, oil temperature at 180°F (82°C) to 200°F (93°C) with transmission in neutral. Maintain oil level at "FULL" mark. Oil and oil filter element are to be changed each time a transmission oil change is directed by AOAP laboratory. Remove filter element, clean filter housing, install new filter element and seal. After replacement, fill transmission to low mark. With engine running, oil at operating temperature, and transmission in neutral (to fill lines and converter) add oil to bring to "FULL" mark. Operate for 5 minutes and check for leaks. When AOAP laboratory support is not available, change transmission oil each 500 hours and transmission oil filter element each 250 hours.

8. AIR CLEANER OIL-BATH (MODEL 2380). Each 10 hours, refill reservoir to level mark. Each 250 hours disassemble entire unit, clean, re-oil and assemble.

9. AIR CLEANER OIL-BATH (CRANE ENGINE). Each 10 hours, refill reservoir to level mark. Each 100 hours disassemble entire unit, clean, re-oil and assemble.

TA221961

**NOTES - CONTINUED:**

10. FAN PULLEY (CRANE ENGINE). Remove plug and insert fitting. Lubricate and reinstall plug.

11. HYDRAULIC OIL FILTER. Each 250 hours, remove filter element, clean filter shell and install new filter element. After replacement, operate hydraulic system for 5 minutes, check for leaks, check level and bring to "FULL" mark.

12. HYDRAULIC OIL RESERVOIR. Relieve pressure in reservoir before removing dipstick to check level. Each 10 hours check level. Maintain oil level at "FULL" mark. Each 1000 hours drain hydraulic system, clean fill cap and oil filter screen. Remove filter element, clean filter shell, and install new filter element. Refill reservoir with OE/HDO 10, operate hydraulic system for 5 minutes, check for leaks, check level and bring to "FULL" mark.

13. FRONT DIFFERENTIAL/REAR DIFFERENTIAL. Each 50 hours check level. Change gear lubricant only when required by maintenance repair action, contamination by water, or other foreign material. After refill, operate for 5 minutes, check for leaks and bring oil level to fill and level plug opening.

14. WHEEL SHAFT UNIVERSAL JOINTS. Using outriggers, raise machine. Turn front and rear wheels full left or right until grease plugs, located in top and bottom of wheel shaft U-joint trunnions, are visible. Remove plug (2 each wheel) and install fittings. Lubricate and reinstall plugs.

15. WHEEL PLANETARIES. Each 100 hours rotate wheel until plug is horizontal with center line of axle. Remove plug, check level and reinstall plug. Change gear lubricant only when required by maintenance repair action, contamination by water, or other foreign material. Rotate wheel until plug is at bottom center, remove plug and drain. Rotate wheel back to level point, fill and reinstall plug. After refill, operate for 5 minutes, check for leaks, and bring oil level to fill and level plug opening.

16. DRIVE SHAFTS. Remove plug and insert fittings. Lubricate and reinstall plug.

17. EXPOSED GEARS/BULL GEAR. Keep exposed gears and pinions coated with CW in sufficient amount to keep bright metal from showing.

18. TAGLINE HOUSING. Keep tagline housing 1/2 full of GO. Do not overfill.

19. CABLES. Each 5 hours clean and coat all cables with OE/HDO, except those coming in constant contact with dirt and excavated material.

20. LUBRICANTS. The following is a list of lubricants with military symbols and applicable specification numbers.

OE/HDO	MIL-L-2104
OEA	MIL-L-46167
GO	MIL-L-2105
BFS	MIL-B-46176
GAA	MIL-G-10924
(SD), Type II	P-D-680
OAI	MIL-L-6085
CW	VV-L-751

Copy of this Lubrication Order will remain with the equipment at all times, instructions contained herein are mandatory.

By order of the Secretary of the Army:

JOHN A. WICKHAM, JR.  
General, United States Army  
Chief of Staff

OFFICIAL:

ROBERT M. JOYCE  
Major General, United States Army  
The Adjutant General

DISTRIBUTION:

To be distributed in accordance with DA Form 12-25B, Operator and Organizational maintenance requirements for WHEEL MOUNTED CRANE.

TA221962

LO 5-3810-232-12

☆U.S. GOVERNMENT PRINTING OFFICE: 1998-432-760/80006



This fine document...

Was brought to you by me:



## [Liberated Manuals -- free army and government manuals](#)

Why do I do it? I am tired of sleazy CD-ROM sellers, who take publicly available information, slap “watermarks” and other junk on it, and sell it. Those masters of search engine manipulation make sure that their sites that sell free information, come up first in search engines. They did not create it... They did not even scan it... Why should they get your money? Why are not letting you give those free manuals to your friends?

I am setting this document FREE. This document was made by the US Government and is NOT protected by Copyright. Feel free to share, republish, sell and so on.

I am not asking you for donations, fees or handouts. If you can, please provide a link to [liberatedmanuals.com](http://liberatedmanuals.com), so that free manuals come up first in search engines:

<A HREF=<http://www.liberatedmanuals.com/>>Free Military and Government Manuals</A>

– Sincerely  
Igor Chudov  
<http://igor.chudov.com/>