

LUBRICATION ORDER

L05-6115-600-12

17 NOVEMBER 1986

(Supersedes LO 5-6115-600-12, 6 FEB 1985)

GENERATOR SET, DIESEL ENGINE DRIVEN, TACTICAL,
SKID MTD., 100 KW, 3 PHASE, 4 WIRE,
120/208 AND 240/416 VOLTS

DOD MODEL
MEPO07B

CLASS
UTILITY

HERTZ
50/60

NSN
6118-01-036-6374

Reference: TM5-6115-600-12, C1900-IL

Intervals (on-condition or hard time) and the related task-hour times are based on normal operation. Change the hard time interval if your lubricants are contaminated or if you are operating the equipment under adverse operating conditions, including longer-than-usual operating hours. The hard time interval may be extended during periods of low activity. If extended, adequate preservation precautions must be taken.

On-condition (OC) intervals for oil changes shall be determined by the Army Oil Analysis Program (AOAP) laboratory and shall be applied unless otherwise notified.

Hard time oil change intervals will be applied in the event AOAP laboratory support is not available.

Clean fittings before lubricating. Clean parts with drycleaning SOLVENT (SD), type II or equivalent. Dry before lubricating.

The lowest level of maintenance authorized to lubricate a point is indicated by one of the following: (C) Operator/Crew; or (O) Organizational Maintenance.

Relubricate after washing or fording.

Drain crankcase when hot. Fill and check level.

*The time specified is the time required to perform all services at the particular interval (On-condition or hard time).

You can help improve this lubrication order. If you find any mistakes or if you know of a way to improve the procedures, please let us know. Mail your letter or DA Form 2028 (Recommended Changes to Publications and Blank Forms) to: Commander, US Army Troop Support Command, ATTN: AMSTR-MCTS, 4300 Goodfellow Blvd, St. Louis, MO 63120-1798. A reply will be furnished to you.

LUBRICANT ● INTERVAL

INTERVAL ● LUBRICANT

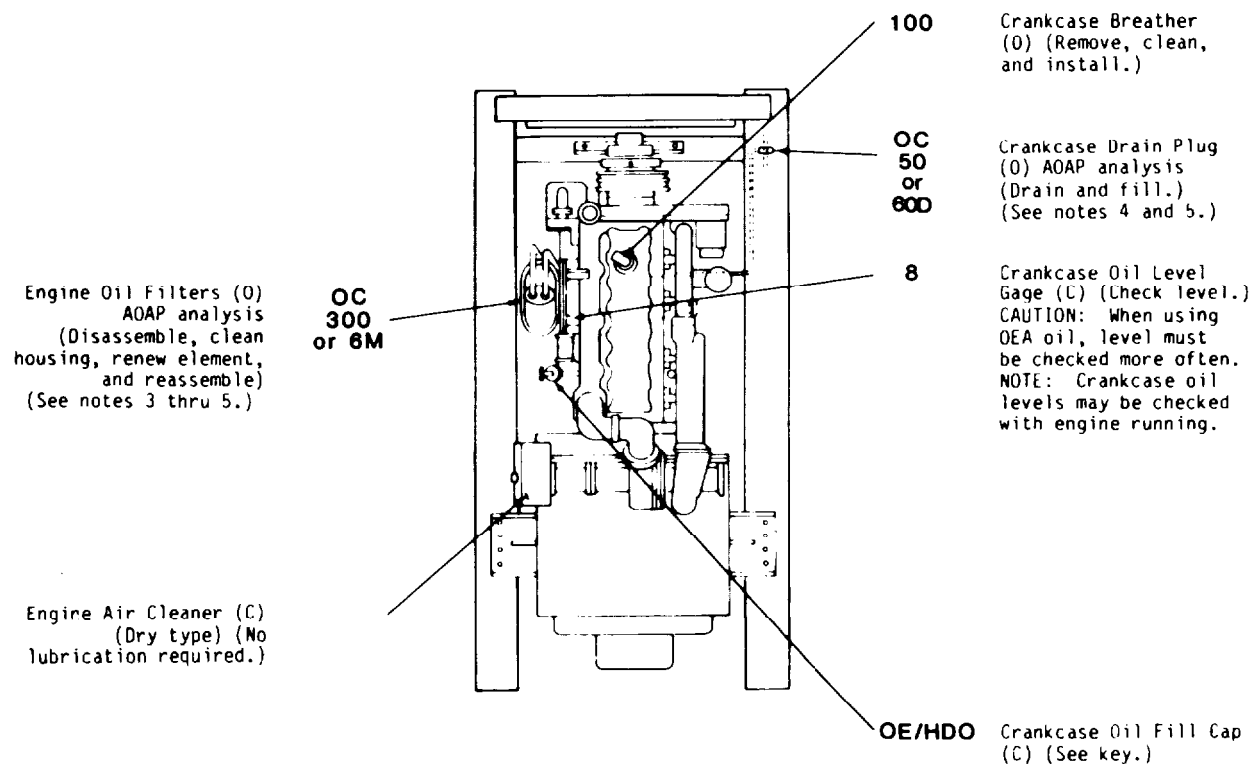

| *TOTAL TASK-HR | | *TOTAL TASK-HR | |
|----------------|---------|----------------|---------|
| INTERVAL | TASK-HR | INTERVAL | TASK-HR |
| 8 | 0.1 | 50 or 60D | 0.6 |
| 100 | 0.4 | | |

-KEY-

| LUBRICANTS | CAPACITY | EXPECTED TEMPERATURES | | | For arctic operation refer to FM 9-207. | INTERVALS |
|---|--------------|----------------------------|-----------------------------------|----------------------------------|--|-----------|
| | | ABOVE +32°F (ABOVE 0°C) | +40°F TO -10°F (+5°C TO -23°C) | 0°F TO -65°F (-18°C TO -50°C) | | |
| OE/HDO (MIL-L-2104D) LUBRICATING OIL, Engine Engine Crankcase with Filters Oil Can Points | 30 qts (28L) | OE/HDO 30 | OE/HDO 10 | OE/A | Intervals given are in hours of normal operation | |
| OE/A (MIL-H-46167) LUBRICATING OIL, Engine, Subzero | 30 qts (28L) | | | | | |

NOTES:

FOR OPERATION OF EQUIPMENT IN PROTRACTED COLD TEMPERATURES BELOW -10°F (-23°C). Remove lubricants prescribed in the key for temperatures above -10°F (-23°C). Clean parts with drycleaning SOLVENT (SD), type II or equivalent. Lubricate with lubricants specified in the key for temperatures 0°F to -65°F.

2. OIL CAN POINTS. Every 100 hours lubricate hinges, latches, control linkages, and all exposed adjusting threads with OE-HDO.

3. ENGINE OIL FILTER. Oil filter replacement interval shall align with on-condition AOAP analysis or hard time oil change requirements. See notes 4 and 5. After installing a new filter element, fill crankcase, operate engine for 5 minutes, and check for leaks. Shut engine down, check crankcase oil level, and bring to full mark.

4. CRANKCASE OIL. A sample of the oil shall be sent to an AOAP laboratory for analysis at an interval of 50 hours or 60 days. Refer to TB 43-0210 for sampling requirements.

5. When AOAP laboratory support is not available, drain and refill crankcase oil at 300 hours or 6 months.

Copy of this Lubrication Order will remain with the equipment at all times; instructions contained herein are mandatory.

By Order of the Secretary of the Army:

JOHN A. WICKHAM, JR.
General, United States Army
Chief of Staff

Official:

R. L. DILWORTH
Brigadier General, United States Army
The Adjutant General

DISTRIBUTION:

To be distributed in accordance with DA Form 12-25A, Operator and Organizational Maintenance requirements for Generator Set, Diesel Driven, 120/208V, 240/416V, 100KW, 50/60 HZ, 3PH, 4 Wire (MEP-008B).

This fine document...

Was brought to you by me:



[Liberated Manuals -- free army and government manuals](#)

Why do I do it? I am tired of sleazy CD-ROM sellers, who take publicly available information, slap “watermarks” and other junk on it, and sell it. Those masters of search engine manipulation make sure that their sites that sell free information, come up first in search engines. They did not create it... They did not even scan it... Why should they get your money? Why are not letting you give those free manuals to your friends?

I am setting this document FREE. This document was made by the US Government and is NOT protected by Copyright. Feel free to share, republish, sell and so on.

I am not asking you for donations, fees or handouts. If you can, please provide a link to liberatedmanuals.com, so that free manuals come up first in search engines:

<A HREF=<http://www.liberatedmanuals.com/>>Free Military and Government Manuals

– Sincerely
Igor Chudov
<http://igor.chudov.com/>