

Historic, archived document

Do not assume content reflects current scientific knowledge, policies, or practices.

430
R31
72-16

ARS-72-16
September 1959

SRRL GRANULAR CARD INSTALLATION MANUAL

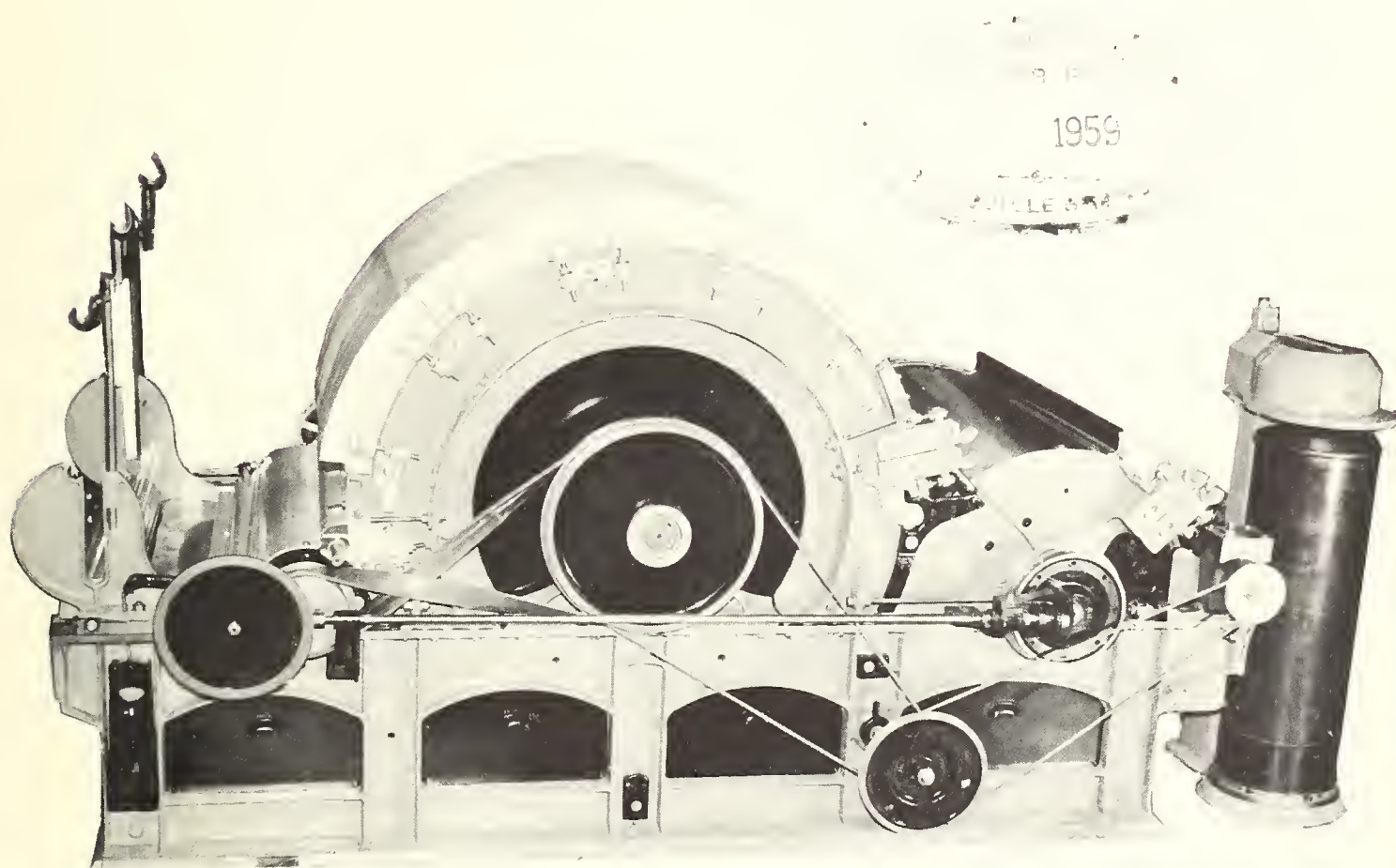

Agricultural Research Service
UNITED STATES DEPARTMENT OF AGRICULTURE

UNITED STATES DEPARTMENT OF AGRICULTURE
AGRICULTURAL RESEARCH SERVICE

SRRL GRANULAR CARD – INSTALLATION MANUAL

By

A. L. Miller, R. S. Brown, and R. A. Rusca

**Southern Regional Research Laboratory¹
New Orleans, Louisiana**

¹ One of the laboratories of the Southern Utilization Research and Development Division, Agricultural Research Service, U. S. Department of Agriculture.

Introduction

The SRRL Granular Card is a development of the Southern Regional Research Laboratory, a unit of the Southern Utilization Research and Development Division, ARS, USDA.

The Granular Card Apparatus¹ is a mechanism for converting revolving flat cotton cards to carding without flats, thereby eliminating all flat waste. On an average, overall card waste is reduced about 50 percent, amounting to a saving of 2 to 3 percent of the total cotton processed. At the same time, neps are reduced slightly. Lower processing costs and improved quality cotton textile products should increase the utilization of cotton.

The carding apparatus is simple insofar as number of parts and intricacy of mechanisms are concerned, however, the importance of dimensional trueness in manufacture, and exactness in erection cannot be over-emphasized. The engineering drawings issued by the Department of Agriculture show the dimensional tolerances that cannot be exceeded except at the risk of lowering the performance of the machine. The question of proper erection of the apparatus, whether by the manufacturer or the mill, is equally important and it is for this reason that this illustrated publication of a recommended procedure is issued.

GENERAL INFORMATION

A carding machine converted from revolving flats to a granular top should ordinarily require no changes from the standard procedure of operation. The speeds of all units of the machine can remain unchanged. However, due to less fiber being extracted, a slightly heavier sliver will result unless the draft of the machine is adjusted.

The frequency of stripping the cylinder and doffer is normally not changed, however, because of the wide variety of cottons being processed, it is recommended that the mill check the performance of the card to determine if the stripping cycle should be changed.

The mill schedule of grinding the cylinder and doffer wire should not be effected. Likewise, the lap weight and production rate of the card should remain the same. Generally, it has been found that adjustments in the processes of roving and spinning will not be required with granular carding. Nevertheless, it is deemed advisable for each mill to observe these subsequent processes to determine if adjustments are required for best performance.

PREPARATION FOR CONVERSION

All of the information contained herein pertains to conversion of a 1948 model Saco-Lowell Card. Procedures for converting other makes or models should be modified according to the differences in design.

Since the performance of every carding machine depends on relatively close settings between moving parts, it is important that the machine be maintained in good working condition. This is particularly true of the bearings of the lickerin, main cylinder, and doffer cylinder. These bearings should be checked for excessive wear and overhauled if necessary. The cylinder should be centered between the arches. The cylinder and doffer should be stripped with a brush and inspected for damaged or dull wire, and ground if necessary.

Remove the complete revolving flat assembly from the card, including the stands, flexible bends and adjusting mechanism. Leave the arch clean except for the makeup pieces and grinding stands. Remove the back knife plate. Check the top edge of the front knife plate and set to .012". It is very important that the top edge of the front plate be parallel to the centerline of the cylinder.

¹ Rusca, R. A., Miller, A. L., and Brown, R. S., *Textile Research Journal*, 28, No. 7, 597-599 (1958). "Carding Without Flats—A Report on the SRRL Card." Miller, A. L., and Brown, R. S., "Design of the SRRL Granular Card," *Textile Research Journal*, in press.

Remove the lickerin cover and feed roll. If the SRRL waste-control cover is to be installed as part of the conversion, the feed roll should have been modified as shown in Figure 1.

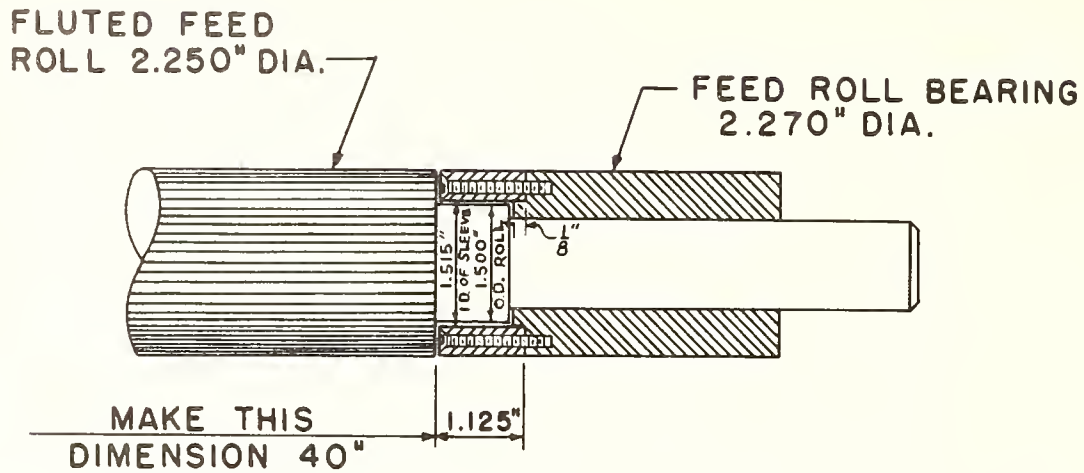

Figure 1. Feed roll and feed roll bearing modification.

The main cylinder should now be covered from the front plate to the lickerin with a single thickness of heavy kraft wrapping paper 36 inches wide.

The card is now ready for installation of the granular apparatus. Although the conversion of a card does not involve changes in the under section, it is recommended that the screens be checked for cleanliness and proper setting.

ERECTION OF GRANULAR TOP PLATES

A general view of the granular card is shown in Figure 2.

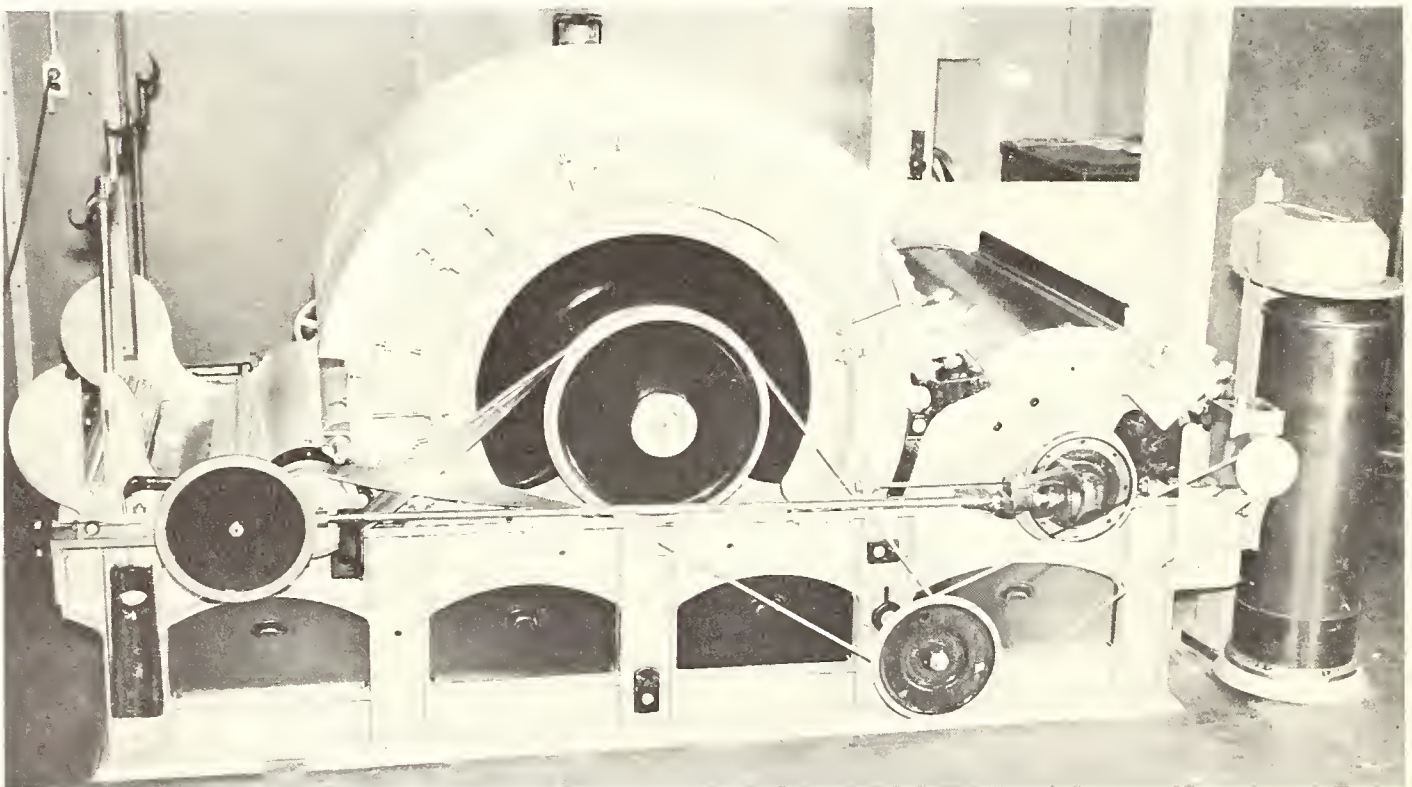

Figure 2. SRRL granular card apparatus on a Standard Card.

There are four top plates per card, all identical and symmetrical end for end. These plates are a specially selected aluminum alloy casting and have been machined to a very close tolerance on the surface which fits to the cylinder. This machined surface should be kept clean and free from oil, and handled carefully to avoid scratching or marring. It is preferable that the top plate assembly be mounted on the card before applying the granular material to the plates. Remove the dust shields before installing the plates. Set the first top plate on the card against the front knife plate. Set a second top plate on the card, adjacent to the first. As shown in Figure 3, insert a spacer (A) between the plates and secure the plates with a C-clamp (b). The spacer should be $1/16''$ thick if the clothing wire

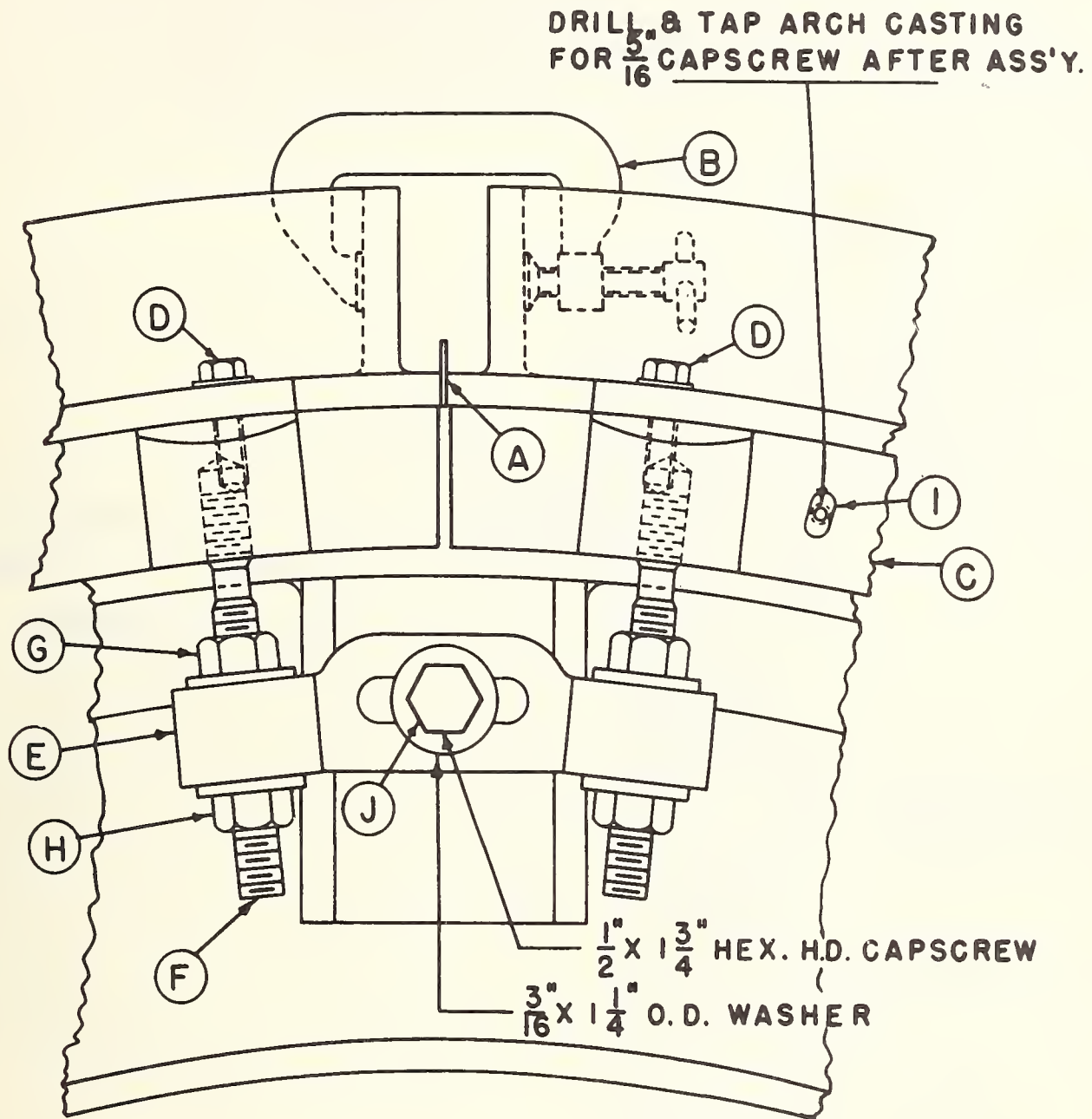

Figure 3. Top Plate mounting.

on the card is new. The thickness should be reduced in proportion to the expired life of the clothing. That is, if the clothing is about half worn, use a $1/32''$ spacer. No spacer is required for metallic clothing. Install the other two top plates with the same procedure. Make sure the top plates are all centered and snug down on the cylinder. It will be necessary to lock the cylinder to keep it from turning under the weight of the top plates.

Next, install the makeup pieces (C) firmly against the arch and fasten in place with screws (D). Keeping the plates snug on the cylinder, drill and tap the arch for the locking screws at (I). The tapped hole should be centered in the slot of the makeup piece if the cylinder clothing is relatively new. If the clothing is worn, raise the hole by the amount of wear. After tapping, clean out all metal chips and dust and install the locking screws. The C-clamps holding the plates can now be removed.

Install one of the adjusting screws (F) tightly into the makeup-piece and install nut (G) with washer. Install bracket (E) and nut (H) with washer. With the screw (F) centered in the hole, adjust the nuts until the slot in the bracket is centered over the hole in the arch, and install screw (J) with its special washer. The other adjusting screw can now be installed through the bracket, making sure to insert the top nut and washer at the same time. When all adjusting screws have been installed, adjust the plates upward about 1-½ turns of the nut to provide space for the granular material, as shown in Figure 4.

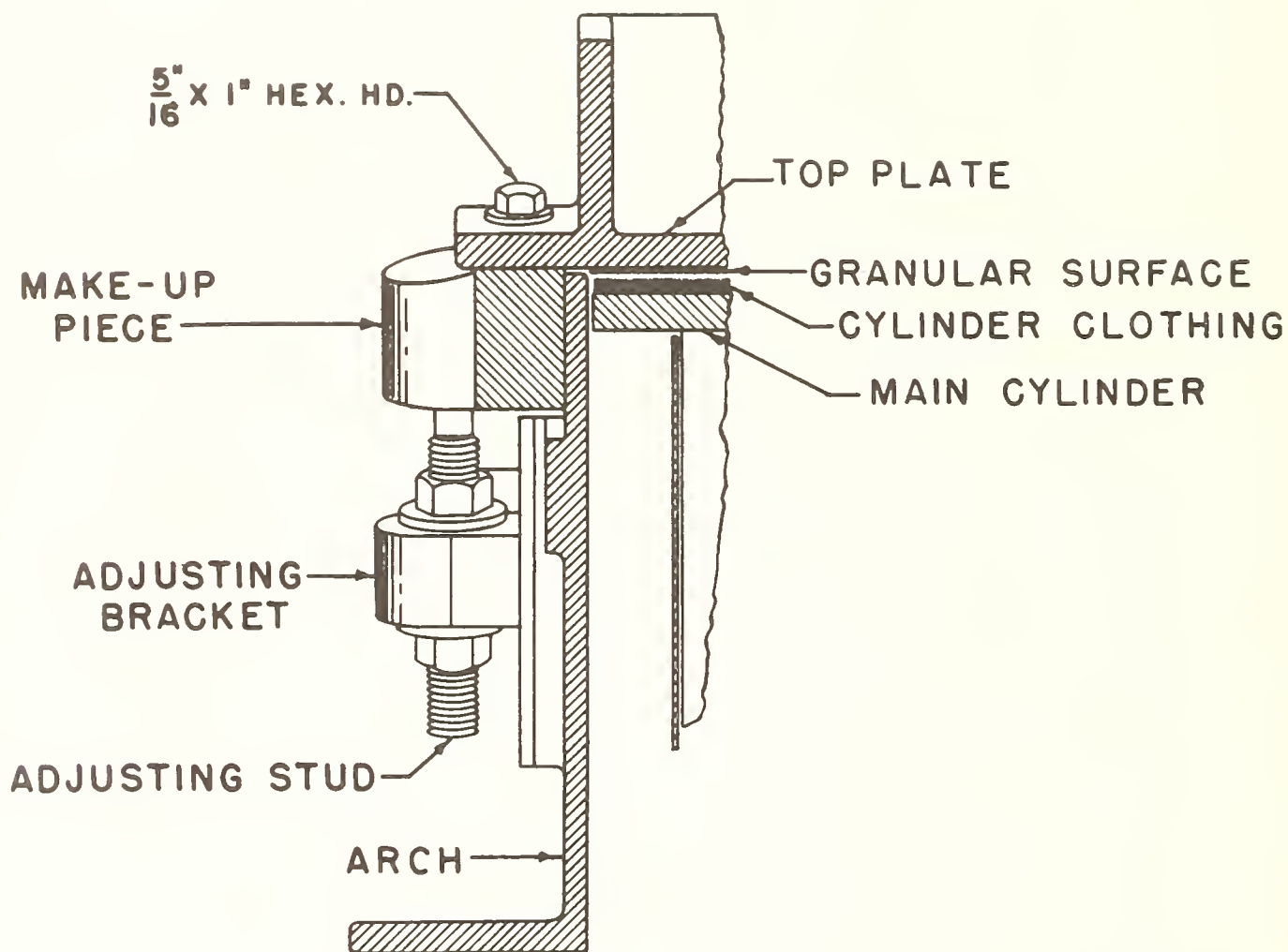

Figure 4. Section through arch.

A close up view of how the installation should look is shown in Figure 5.

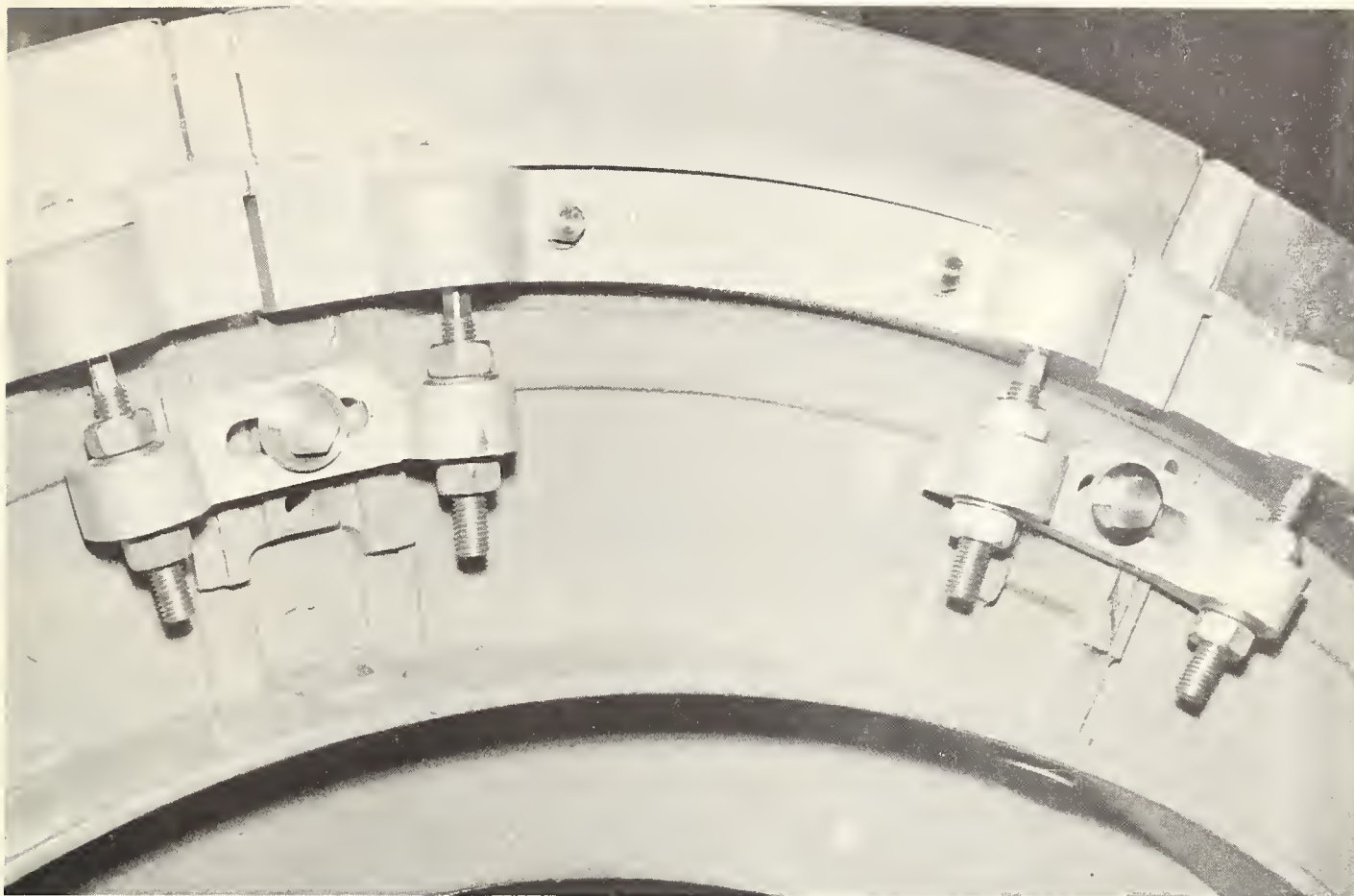

Figure 5. *Mounting brackets.*

Remove the plates from the card and install the dust shields before installation of the granular material. The kraft paper over the cylinder can also be removed. Installing the granular material should be done in a clean location where the air is free from dust and lint. On new plates, the machined surface should be thoroughly cleaned with acetone or pure white gasoline to remove all traces of oil. Take necessary safety precautions with these solvents. A sturdy table or two wooden horses with blocks are needed to support the plate in a rigid position. If the granular material is in sheets 8" x 15-1/2", draw a line across the plate 4" to one side of the centerline. This is the edge of the center sheet. The granular material has an adhesive back which is exposed by peeling off the cover sheet. Install the center sheet first and then work to each side. The material should be installed as shown in Figure 6. Holding the sheet across the plate, press down one end leaving an overhang of about 1/8". From that end, roll down the material with a 10" wide x 4" diameter rubber covered roll making sure to avoid air pockets or bulges. The other sheets should be carefully lined up before rolling down to avoid overlapping. If a sheet shows a tendency to overlap the adjacent sheet, it should be removed and reinstalled. When the five sheets have been installed, trim the ends with a sharp knife using a shearing action against the plate. It is well then to use another rubber covered roll about 2" wide and roll down the surface again to insure good contact.

The top plates can now be installed on the card and the following procedure is recommended. Referring to the top plates as numbers 1, 2, 3, and 4, from front to back, install plates, numbers 1 and 3. Remove the top section of the front knife plate to facilitate gauging the top plate. Loosen all locking screws in the makeup pieces. Using a standard card leaf-gauge set the two corners of plate No. 1 on the same side of the card to 7/1000." Then set the two corners on the opposite side of plate No. 1 to 7/1000." Using the 7/1000" gauge,

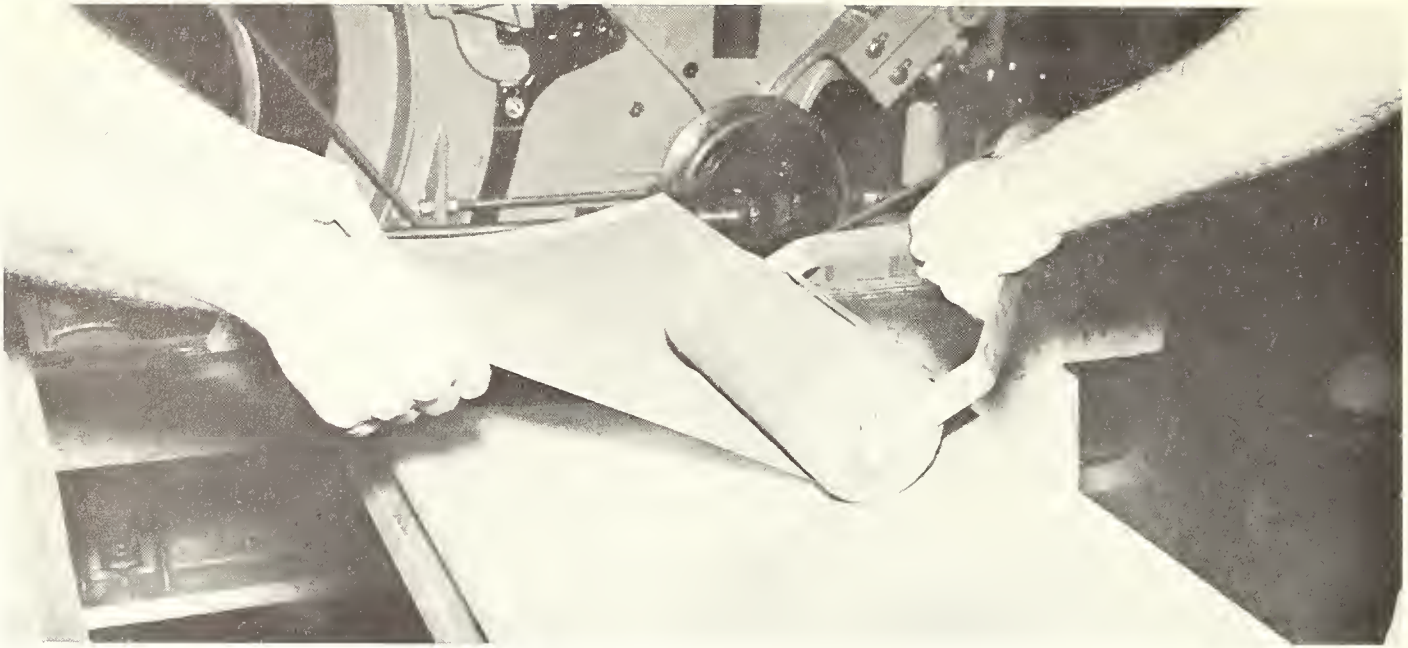

Figure 6. *PSA Three-M-ite Material being installed.*

check the entire plate area, gauging from the cylinder to the outside edge. It is preferable to bring the plate down until the gauge binds and then back off slightly to achieve a $7/1000''$ setting. After the card has run sufficiently to reach its normal operating temperature, the setting should be $5/1000''$ and should be checked with the $5/1000''$ gauge under those conditions. After the plates are set, tighten the locking screws. Install plates 2 and 4 and remove plates 1 and 3. Set plates 2 and 4 by the same procedure, and when finished reinstall plates 1 and 3. Check all locking screws and install the seals between plates.

INSTALLING THE PRE-OPENER ROLL

The pre-opener roll is shown on the card in Figure 7.

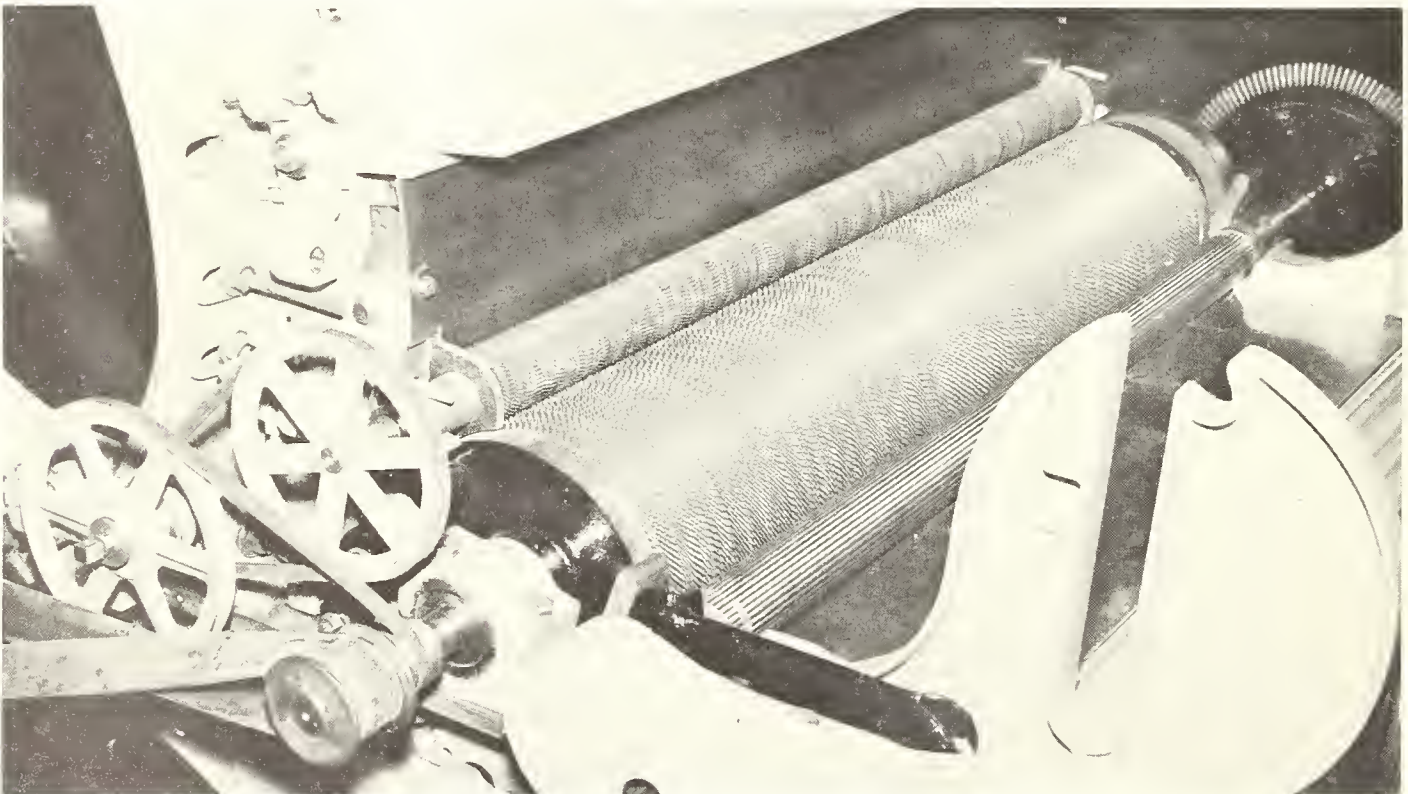

Figure 7. *Pre-opener roll.*

Before installing the roll, clean the edge of the arch from the lickerin to the top of the back plate, by scraping and wiping with mineral spirits. Apply the $\frac{1}{8}$ " x $\frac{3}{8}$ " sponge rubber self-adhesive seal strip on the arch as shown in Figure 8. Install the brackets for

$\frac{1}{8}$ " x $\frac{3}{8}$ " SPONGE RUBBER, SELF-ADHESIVE SEAL STRIP ON ARCH.

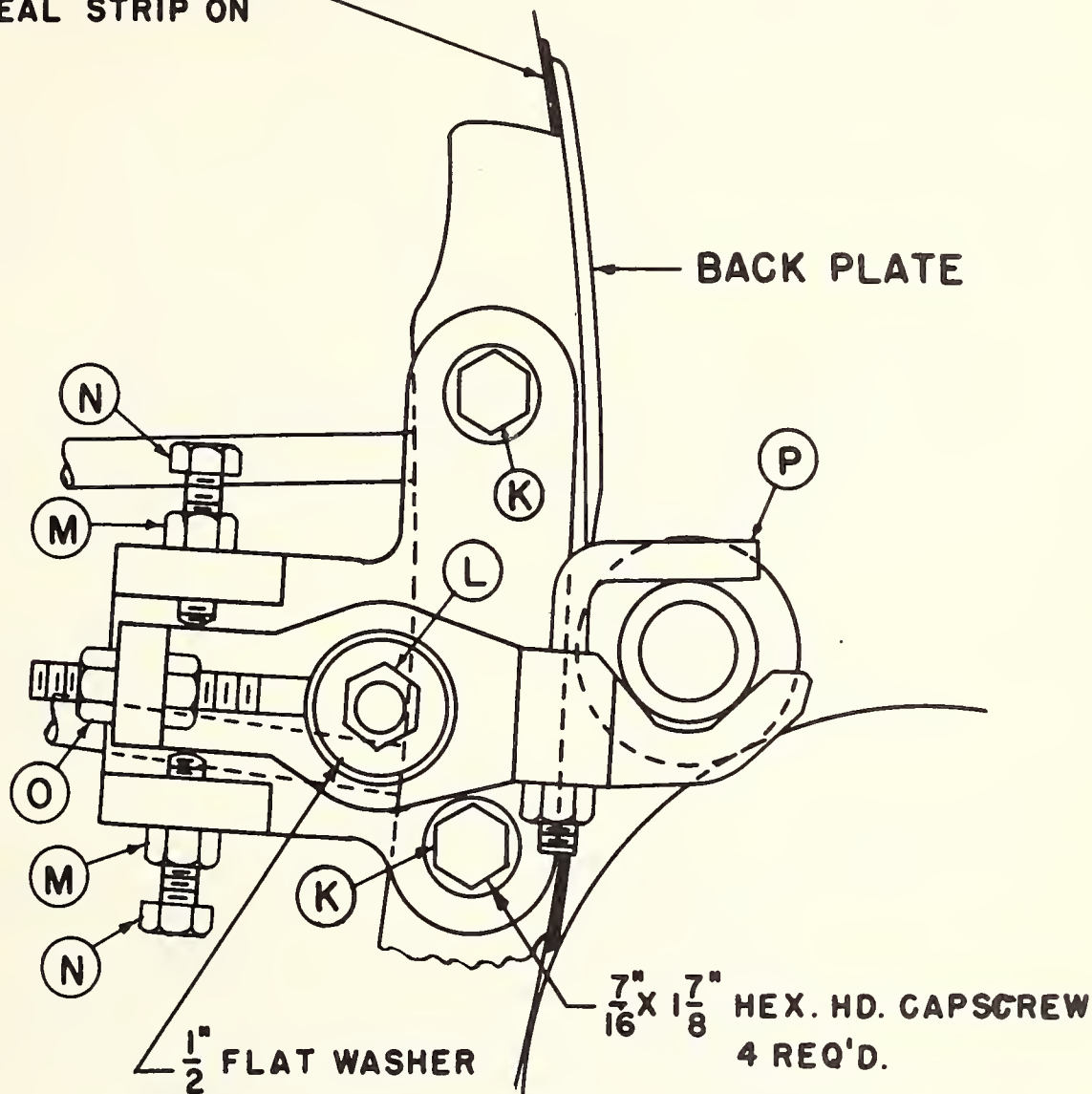

Figure 8. Pre-opener roll bracket.

the pre-opener roll, allowing them to hang loosely on their screws. The brackets are held in place by the screws which hold the makeup pieces. These screws must be $\frac{1}{2}$ " longer than standard. (On older model cards these screws are replaced by special studs.)

With 3 wraps of kraft paper around the pre-opener roll, set the roll in place resting it on the lickerin and main cylinder. Make sure the teeth on the roll point in a direction opposite to those on the main cylinder. Center the roll on the face of the cylinder and install the bearings snugly against the ends of the roll. Adjust the bracket to its position by tightening clamp (P) in Figure 8, making sure bracket will not interfere with back knife plate. Tighten screws (K) securely to fasten the bracket to the card. Adjust screw (L) to be snug but not tight. Back off the two locknuts (M). Adjust screws (N) to raise the roll off the lickerin and adjust nuts (O) to move the roll out from the cylinder. When this is done, and the roll turns freely, remove the paper from around the roll and set the roll .010" from the

lickering and .007" from the cylinder. Use a leaf gauge for setting the roll. When the desired setting has been obtained, tighten lock nuts (M), and then tighten screw (L), and recheck the setting.

The back knife plate, must be reduced in size, as shown in Figure 9. If a special

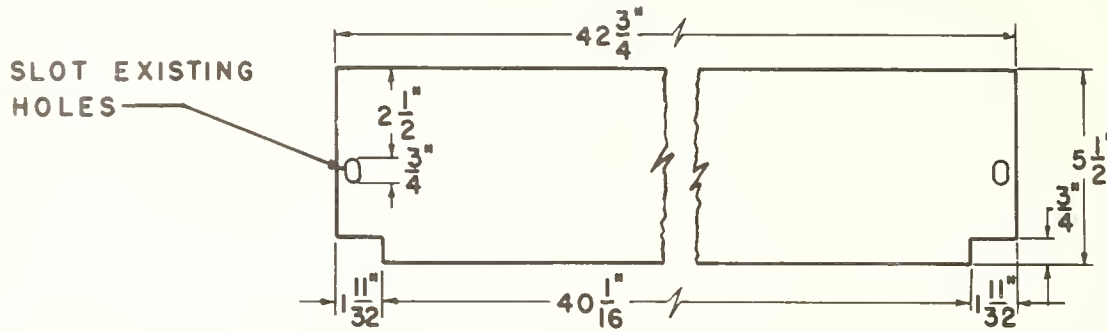

Figure 9. Back plate.

back plate is not furnished with the granular card apparatus the standard plate can be cut, however, the cut edge must be straight and true to achieve a dust-tight fit.

Install the back plate, lifting it against the granular top-plate to close the opening. The space between the tapered lower edge of the back plate and the pre-opener roll should

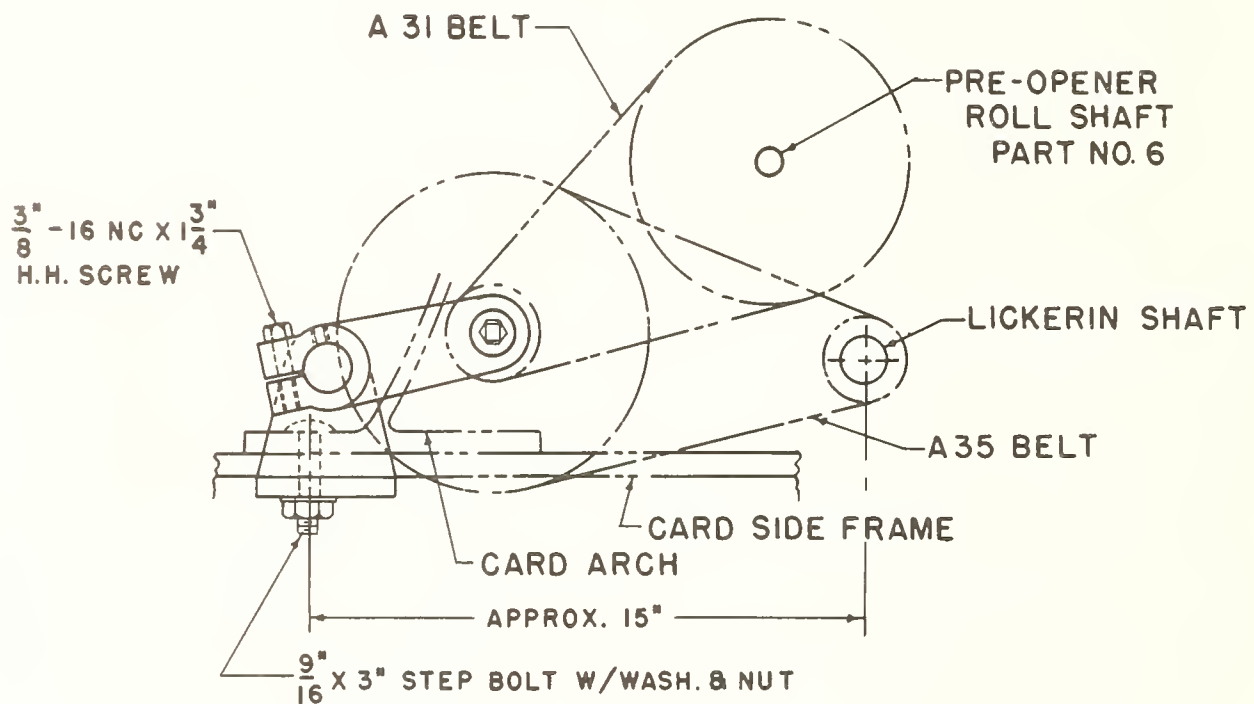

Figure 10. Pre-opener roll drive.

be between 1 8" and 3 16" (Figure 11). The belt drive for the pre-opener roll is shown in Figure 7 and in Figure 10. The installation should be evident from these views.

INSTALLING THE WASTE-CONTROL LICKERIN COVER

The three-piece cover, which encloses the pre-opener roll, lickerin and feed roll, does not depend on close settings or close tolerance fits for proper operation. It is important

that the covers fit to the shrouds and to each other sufficiently well to prevent air leaks which will cause fly to accumulate that will eventually be plucked in by the lickerin. Figure 11 shows a section through the lickerin with the cover assembly in place. Cover (P) should

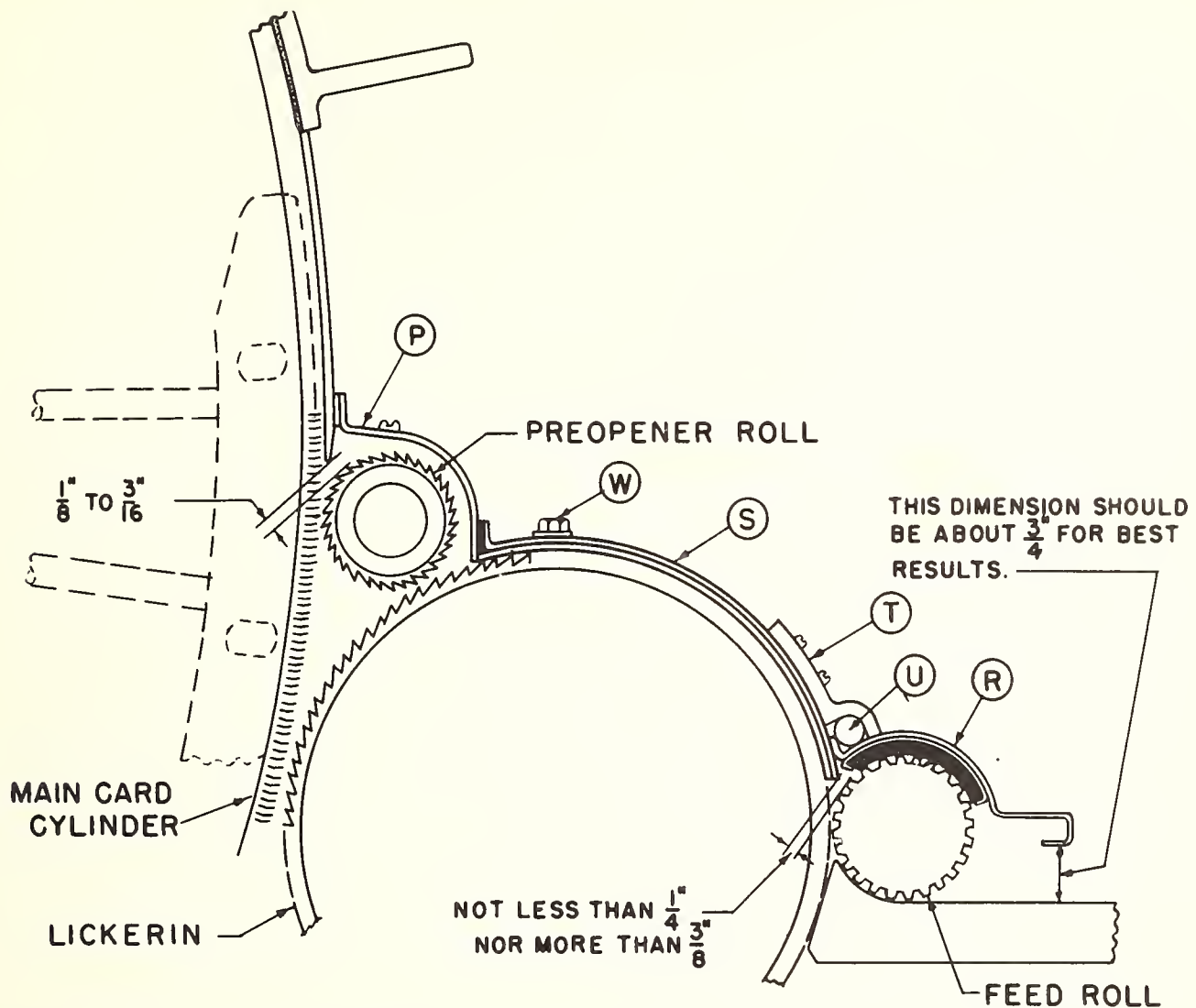

Figure 11. Section of card showing waste-control cover.

be installed first over the pre-opener roll. It is held in place by one small screw at each end. It is not necessary thereafter to remove this part of the cover in order to remove the roll, the whole assembly will come out as a unit. Next, place the cover (R) on the feed roll. Then install cover (S) so that the clamp (T) fits over the hinge rod (U). Start the screws (W) in their holes but do not tighten. Install the special lap guides and adjust the cover so that it is centered in the guides. Then with cover (S) snugly against cover (P), tighten the screws (W). The cover on the feed roll should hinge up and down freely and should stay in the up position when desired.

Before the card is put in production, turn it over slowly and observe it carefully to make sure all units turn freely. Slight rubbing of the cylinder wires on the granular surface can be detected by pressing one ear against the top of the plate as the cylinder turns.

