









# AIR COMPRESSORS AND BLOWING ENGINES.

SPECIALLY ADAPTED FOR ENGINEERS.

BY

CHAS. H. INNES, M.A.,

*Lecturer on Engineering at Rutherford College, Newcastle-on-Tyne ;*

Author of "Problems in Machine Design," "Centrifugal Pumps, Turbines,  
and Water Motors," "The Fan," &c.



1906.

THE TECHNICAL PUBLISHING CO. LIMITED,

287, DEANSGATE, MANCHESTER, AND 359, STRAND, LONDON ;

D. VAN NOSTRAND CO., 23, Murray Street, and 27, Warren Street, New York ;

E. W. COLE, Sydney and Melbourne, Australia ;

GEO. ROBERTSON AND CO. PROPRIETARY LIMITED, Melbourne, Sydney, Adelaide,  
and Brisbane ; and all Booksellers.

TJ 950  
I 6

GENERAL



THIS BOOK IS DEDICATED

TO THE

PEOPLE OF TYNESIDE,

WHOSE INTELLIGENT APPRECIATION OF SCIENTIFIC

KNOWLEDGE IS SO WELL KNOWN.

187724

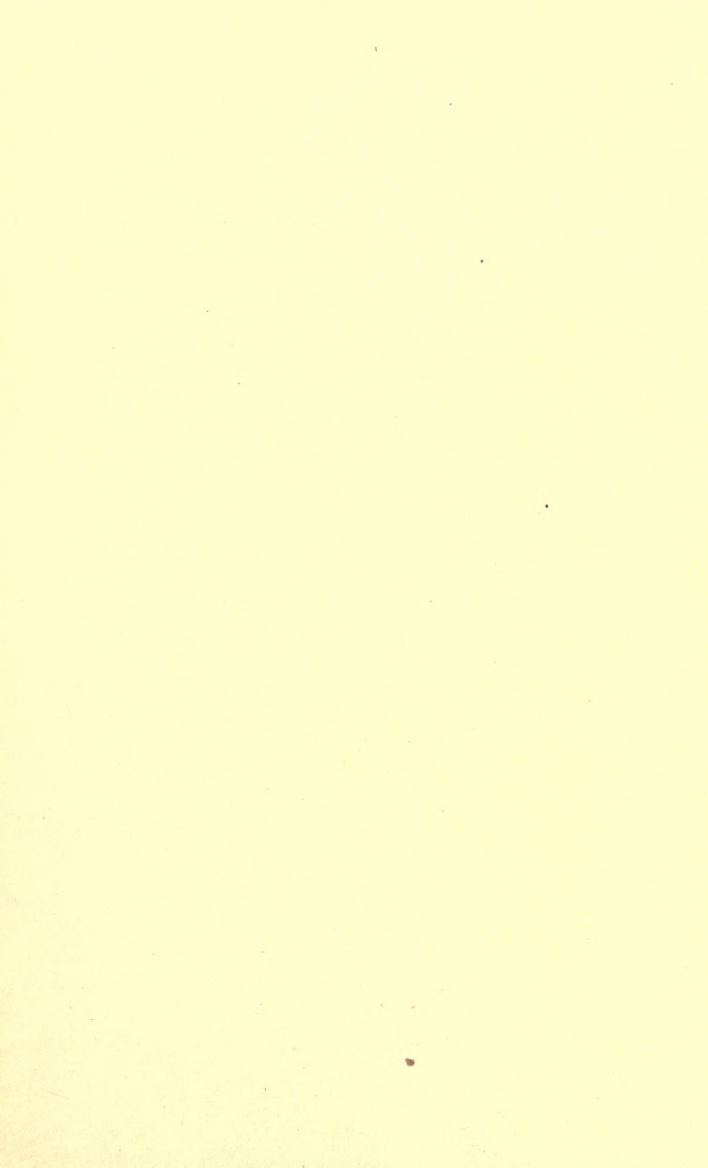

## P R E F A C E .

---

THE following work deals with the construction of Blowing Engines and Air Compressors, and is reprinted from a series of articles which originally appeared in *The Practical Engineer*. The first chapter discusses the properties of air, and shows how to calculate the work required for compression under various circumstances. The second describes several experiments with compressors, and explains the methods of calculating the various efficiencies. The third deals with the theory of valves for equalisation of pressure, and the fourth is devoted to the construction of Blowing Engines. Chapter V. commences the description of Air Compressors. These have self-acting valves, and the remainder of the book is devoted to those with mechanically controlled valves.

I take this opportunity of thanking the many firms who have supplied me with information concerning their machines.

C. H. INNES.

Rutherford College,  
Newcastle-on-Tyne, August, 1906.

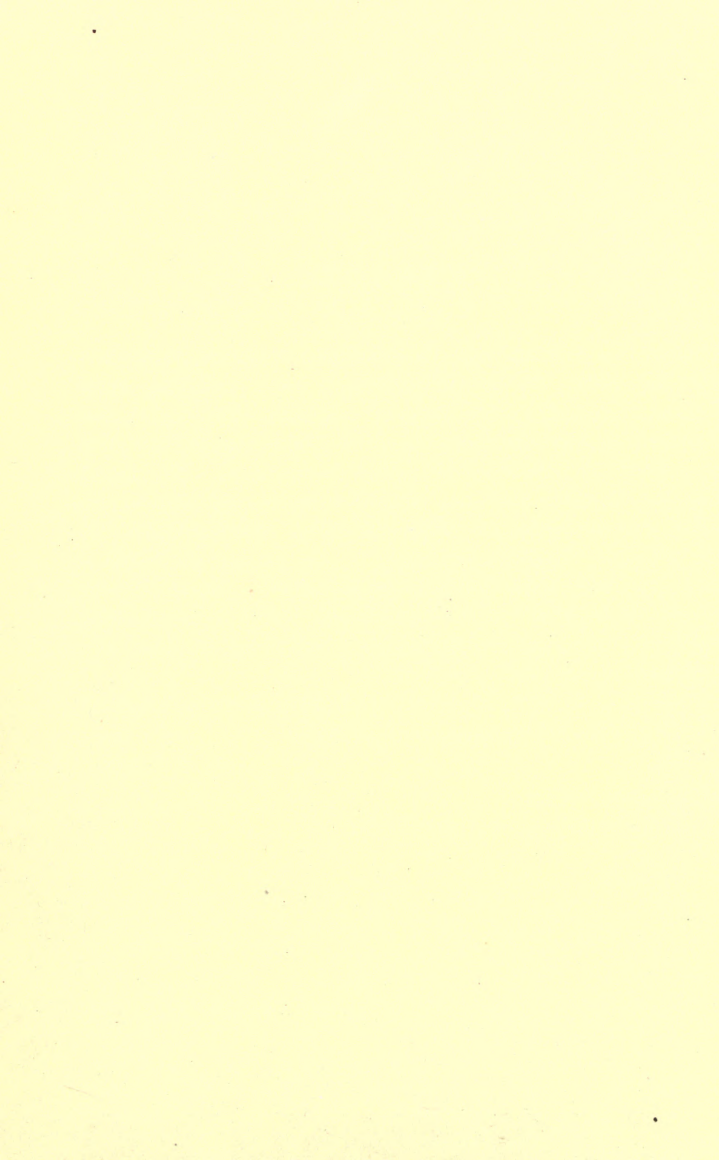

# CONTENTS.

---

## CHAPTER I.

PAGE

Physical Properties of Air ..... 1

## CHAPTER II.

Experiments with Compressors ..... 31

## CHAPTER III.

Valves for Producing Equalisation of Pressure..... 39

## CHAPTER IV.

Blowing Engines ..... 44

## CHAPTER V.

Air Compressors ..... 123

## CHAPTER VI.

Air Compressors—*continued* ..... 197





# AIR COMPRESSORS

AND

# BLOWING ENGINES.

---

---

## CHAPTER I.

### PHYSICAL PROPERTIES OF AIR.

1. *Physical Properties of Air.*—Air is a gas, and therefore

$$144 p v = R t \quad . \quad . \quad . \quad . \quad . \quad (1)$$

where  $p$  is pressure in pounds per square inch,  $v$  is the number of cubic feet per pound, or the specific volume  $t$  is the absolute temperature; so that

$$t = F + 460.6,$$

or 
$$= C + 273.7,$$

where  $F$  is its temperature in Fahrenheit and  $C$  in Centigrade degrees. If the former scale is used,  $R = 53.2$ , and if the latter,  $R = 95.8$ . When air is compressed or expands isothermally, or at a constant temperature,

$$p v = \text{constant} \quad . \quad . \quad . \quad . \quad . \quad (2)$$

but when it is compressed or expands adiabatically—*i.e.*, without gain or loss of heat,

$$p v^\gamma = \text{constant} \quad . \quad . \quad . \quad . \quad . \quad (3)$$

where

$$\gamma = 1.408$$

$$= \frac{K_p}{K_v}$$

where  $K_p$  and  $K_v$  are the capacities for heat expressed in foot-pounds of a pound of air at constant pressure and constant volume. Equation (3) is proved in most works on the steam engine.\* It is also important to remember that, if a pound of gas changes its pressure and volume in any manner,

$$H = W + K_v (t_1 - t_2)$$

where  $H$  is the heat taken in,  $W$  is the work done by the gas, and  $t_2, t_1$  are the initial and final temperatures. Hence, if the gas is compressed,  $W$  is negative, and  $H$  is negative; so that if

$$W = -U_o, \text{ and } H = -H_1$$

$$H = -U_o + K_v (t_1 - t_2)$$

or 
$$H_1 = U_o - K_v (t_1 - t_2) \quad . \quad . \quad . \quad (4)$$

or  $H_1$ , the heat in foot-pounds given out by the gas, is the difference between the work in foot-pounds done upon it and the internal heat in foot-pounds added to the gas.

2. *Work Required to Compress Air.*—Let FC, fig. 1, represent a volume  $v_2$  of air, and let EG represent  $v_1$  the volume to which it is compressed, the pressure changing from  $p_2$  at C to  $p_1$  at B, and the air being forced out into a large reservoir, in which the pressure is kept constant. Then, if we first assume isothermal compression between C and B, the work done while the volume changes from  $v_2$  to  $v_1$  is

$$\begin{aligned} U_1 &= 144 \int_{v_1}^{v_2} p \, dv = 144 \int_{v_1}^{v_2} \frac{k \, dv}{v} = 144 k \text{ hyp. log } \frac{v_2}{v_1} \\ &= 144 p_1 v_1 \text{ hyp. log } \frac{p_1}{p_2} = 144 p_2 v_2 \text{ hyp. log } \frac{p_1}{p_2}. \end{aligned}$$

The work done during the expulsion of the air is

$$U_2 = 144 p_1 v_1 = 144 p_2 v_2,$$

---

\* "The Steam Engine," by Cotterill, Holmes, or Perry.



and that done by the atmospheric air upon the suction side of the compressing piston is

$$U_3 = 144 p_1 v_1 = 144 p_2 v_2;$$

hence the total work done is

$$U = U_1 + U_2 - U_3 = 144 p_2 v_2 \text{ hyp. log } \frac{p_1}{p_2} . . (5)$$

The four quantities,  $U_1$ ,  $U_2$ ,  $U_3$ ,  $U$ , are represented in fig. 1 by the areas  $GBCD$ ,  $GBAE$ ,  $FCDE$ , and  $ABCF$ . Equation (5) shows us that, no matter what the temperature

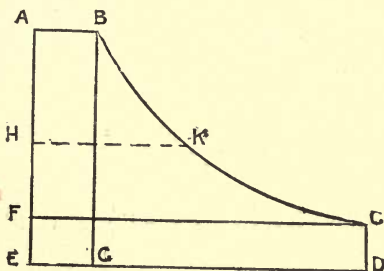

FIG. 1.

may be, to compress a given volume  $v_2$  from pressure  $p_2$  to  $p_1$  requires a fixed quantity of work. But if it is the weight of air that must be considered, the matter is different; then

$$U = R t_2 \text{ hyp. log } \frac{p_1}{p_2} \text{ per lb. . . . . (5a)}$$

so that the lower the temperature the less  $U$  becomes.  $U$  is the least quantity of work required to compress a given volume  $v_2$  from  $p_2$  to  $p_1$ . Equation (4) shows us that the heat given out is equal to the useful work done upon the air for  $t_2 = t_1$ . Isothermal compression is, however, not the rule, and is unattainable unless cooling water can be obtained considerably colder than the atmosphere.

Let us next consider the case of compression when the curve  $CB$  follows the law

$$p v^n = k.$$

Then

$$U_1 = \int_{v_1}^{v_2} 144 p \, dv = 144 \int_{v_1}^{v_2} \frac{k \, dv}{v^n} = \frac{144 k}{n-1} (v_1^{1-n} - v_2^{1-n})$$

$$= \frac{144}{n-1} (p_1 v_1 - p_2 v_2).$$

$U_2$  and  $U_3$  have the same values as before, so that

$$U = U_1 + U_2 - U_3 = \frac{144 n}{n-1} (p_1 v_1 - p_2 v_2). \quad (6)$$

or

$$U = \frac{144 n}{n-1} p_2 v_2 \left( \frac{p_1 v_1}{p_2 v_2} - 1 \right)$$

$$= \frac{144 n}{n-1} p_2 v_2 \left\{ \left( \frac{p_1}{p_2} \right)^{\frac{n-1}{n}} - 1 \right\} \dots \dots \dots (6a)$$

$$= \frac{n-1}{n} R t_2 \left\{ \left( \frac{p_1}{p_2} \right)^{\frac{n-1}{n}} - 1 \right\} \dots \dots \dots (6b)$$

per pound; so that the work per pound decreases with the initial temperature, but is fixed for given values of  $p_1$ ,  $p_2$ , and  $v_2$ . If the compression is adiabatic,  $\gamma$  must be substituted for  $n$  in equations (6), (6a), and (6b).

*Numerical Example.*—To find the work required to compress 1 cubic foot of atmospheric air of pressure 14.7 lb. per square inch to a pressure of 4 atmospheres absolute.

First, assuming isothermal compression,

$$p_2 = 14.7,$$

$$v_2 = 1,$$

$$\frac{p_1}{p_2} = 4.$$

From (5)

$$U = 144 p_2 v_2 \text{ hyp. log } \frac{p_1}{p_2} = 144 \times 14.7 \text{ hyp. log } 4$$

$$= 2931 \text{ foot-pounds.}$$

Secondly, supposing that the compression is adiabatic, from (6a),

$$U = \frac{144n}{n-1} p_2 v_2 \left\{ \left( \frac{p_1}{p_2} \right)^{\frac{n-1}{n}} - 1 \right\} = \frac{144 \times 1.408 \times 14.7}{.408} \times \{4^{.29} - 1\} = \frac{144 \times 1.408 \times 14.7 \times .495}{.408} = 3613 \text{ ft.-lbs.}$$

This is 682 foot-pounds more than with isothermal compression.

3. *Total and Volumetric Efficiencies.*—In any machine the useful work done is less than that which must be done by the agent, owing to friction and other losses. Thus, if U is the useful work calculated from equation (5), and I is the indicated work done in the same period by a steam engine driving the compressor, then the total efficiency of air compressor and steam engine is

$$\eta_1 = \frac{U}{I} \quad . . . . . (7)$$

But it is often convenient to be able to compare the actual work done upon the air, as obtained by indicating the air compressor cylinder, with the least quantity of work ideally necessary to obtain the same final pressure with the same quantity of air. This will be called the *air efficiency*,\* and if U<sub>4</sub> is the quantity of work for a given volume of atmospheric air v<sub>2</sub> obtained from the indicator diagram of the air cylinders, then the air efficiency

$$\eta_2 = \frac{144 p_2 v_2 \text{ hyp. log } \frac{p_1}{p_2}}{U_4} \quad . . . . . (8)$$

A compressor never delivers a quantity of air corresponding to the volume swept out by the piston, because the pressure in the cylinder at the end of the suction stroke is usually a little less than that of the atmosphere, and also because the air in the clearance must expand from p<sub>1</sub> to p<sub>2</sub> before the suction valves can open. Let Q be the number of cubic feet of air at atmospheric pressure actually taken in

---

\* Also called the efficiency of compression.

per minute, let A be the piston area in square inches for a single-acting compressor, and let A<sub>1</sub>, A<sub>2</sub> be the areas on either side for a double-acting compressor, while L and R are the stroke in feet and revolutions per minute respectively. Then the volumetric efficiency

$$\eta_3 = \frac{144 Q}{A L R} \dots \dots \dots (9)$$

for a single-acting compressor, and

$$\eta_3 = \frac{144 Q}{(A_1 + A_2) L R} \dots \dots \dots (9a)$$

for a double-acting compressor.

*Numerical Examples.*—(1) What is the air efficiency in the numerical example of section 2, assuming adiabatic compression,

$$\eta_2 = \frac{2931}{3613} = 74.91 \text{ per cent, } \text{wet} \downarrow \text{ } 81.2\%$$

showing the necessity for cooling the air during compression if a high efficiency is to be obtained.

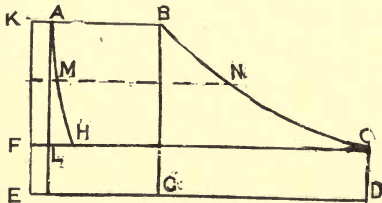

FIG. 2.

(2) What is the volumetric efficiency of a double-acting compressor whose piston areas are 160 and 140 square inches, with a stroke of 2 ft., making 100 revolutions per minute, the actual volume of air delivered (reduced to atmospheric pressure and temperature) being 333 cubic feet,

$$\eta_3 = \frac{144 \times 333}{(160 + 140) \times 200} = 79.92 \text{ per cent.}$$

4. *On the Effect of Clearance.*—In section 2 we have neglected cylinder clearance, and although this does not affect equations (5) to (6*b*) supposing  $v_2$  is the volume of atmospheric air compressed, nor the value of  $\eta_2$  in (8), it is interesting to see how this is the case. Let  $V_2$  be the cylinder volume, or that swept out by the piston in one stroke in cubic feet, and let  $c V_2$  be the volume of the clearance. In fig. 2 CL is the cylinder volume, FL the clearance, while CB and AH are curves of compression and expansion. The latter takes place during the commencement of the return stroke, the air expanding from the clearance, and the suction valves do not open until the point H is reached, so that the volume  $v_2$  of air drawn in is represented by CH. Since air does not accumulate in the cylinder, it is clear that

$$\frac{CH}{AB} \text{ in fig. 2} = \frac{CF}{AB} \text{ in fig. 1,}$$

for AH and BC follow the same law,  $p v^n = \text{constant}$ , and if HC in fig. 2 = FC in fig. 1, and HK and MN are at the same height in figs. 1 and 2 respectively, then HK = MN, so that the area ABCF in fig. 1 = area ABCH in fig. 2, and as these are the indicator diagrams in the two cases, the work done in each case is the same for a given exponent  $n$ . Let us first suppose isothermal compression; then, reasoning as in section 2, the work represented by the area

$$KBCF = 144 p_2 V_2 (1 + c) \text{ hyp. log } \frac{p_1}{p_2}$$

and since

$$FH = c V_2 \frac{p_1}{p_2}$$

$$KAHF = 144 p_2 c V_2 \frac{p_1}{p_2} \text{ hyp. log } \frac{p_1}{p_2} = 144 p_1 c V_2 \text{ hyp. log } \frac{p_1}{p_2}$$

so that

$$U = ABCH = 144 V_2 \{ p_2 (1 + c) - p_1 c \} \text{ hyp. log } \frac{p_1}{p_2}. \quad (10)$$

the useful work done per stroke, which it will be noticed becomes zero when

$$\frac{p_1}{p_2} = \frac{(1 + c)}{c}$$

that is, when B and A coincide.

The volumetric efficiency is

$$\eta_3 = \frac{HC}{LC} = 1 + c - \frac{p_1}{p_2} c \quad \dots \quad (11)$$

so that as the pressure increases the atmospheric air discharged per stroke becomes less.

If the exponent  $n$  is greater than unity,

$$KBCF = \frac{144n}{n-1} p_2 V_2 (1+c) \left\{ \left( \frac{p_1}{p_2} \right)^{\frac{n-1}{n}} - 1 \right\}$$

$$KAHF = \frac{144n}{n-1} p_2 V_2 c \left( \frac{p_1}{p_2} \right)^{\frac{1}{n}} \left\{ \left( \frac{p_1}{p_2} \right)^{\frac{n-1}{n}} - 1 \right\}$$

so that

$$U = ABCH = \frac{144n}{n-1} p_2 V_2 \left\{ \left( \frac{p_1}{p_2} \right)^{\frac{n-1}{n}} - 1 \right\} \left\{ 1 + c - c \left( \frac{p_1}{p_2} \right)^{\frac{1}{n}} \right\} \quad \dots \quad (12)$$

which becomes zero when

$$\left( \frac{p_1}{p_2} \right)^{\frac{1}{n}} = \frac{1+c}{c}$$

and the volumetric efficiency

$$\eta_3 = 1 + c - c \left( \frac{p_1}{p_2} \right)^{\frac{1}{n}} \quad \dots \quad (13)$$

*Numerical Example.*—The cylinder volume is 1 cubic foot, the clearance is one-fifth of the cylinder volume, and the compression is to 4 atmospheres; to find the work per stroke, and the volumetric efficiency. First assuming isothermal compression, and using equation (10),

$$\begin{aligned} U &= 144 \times 14.7 \left\{ 1\frac{1}{5} - \frac{4}{5} \right\} \text{hyp. log } 4 \\ &= 144 \times 14.7 \times \frac{2}{5} \times 2.3 \times .6021 \\ &= 1172 \text{ foot-pounds.} \end{aligned}$$

exactly two-fifths of what it was in section 2. The volumetric efficiency from (11) is

$$\eta_3 = \frac{2}{5} = 40 \text{ per cent.}$$

Next assuming adiabatic compression, with  $n = 1.408$ , using (12),

$$\begin{aligned} U &= \frac{144}{.29} \times 14.7 \{4^{.29} - 1\} \left\{1\frac{1}{5} - \frac{1}{5} (4)^{.71}\right\} \\ &= \frac{144 \times 14.7 \times .495 \times 3.324}{.29 \times 5} \\ &= 2402 \text{ ft.-lbs.} \end{aligned}$$

The volumetric efficiency from (13) is

$$\eta = 1\frac{1}{5} - \frac{1}{5} \times 4^{.71} = 66.48 \text{ per cent.}$$

In both of these cases it is evident that an increase in the volumetric efficiency would be an advantage, even if it were obtained with some slight loss of air efficiency, for we must

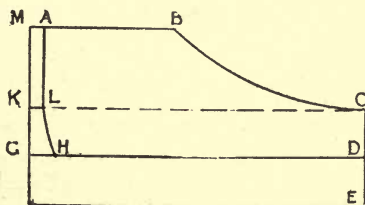

FIG. 3.

consider losses by friction, and weight per horse power, in fixing the dimensions of any machine. If the size of a machine is excessive in proportion to power, the mechanical efficiency will be low, owing to friction, although the air efficiency may be high, and the cost will be greater; so that a small machine with a comparatively low air efficiency may be better in every way than a larger one in which it is higher.

5. *Equalisation of Pressure on both Sides of the Piston at the End of the Stroke.*—The reduction of volumetric efficiency being due to the expansion of the compressed air in the clearance space, if some of this compressed air is transferred to the other side of the piston, where compression is commencing, there will be a considerable increase in the volumetric efficiency. In fig. 3 A M is the clearance volume  $cV_2$ , and the air in this, at a pressure  $p_1$ , is put in communication with the air at the other side, whose pressure is  $p_2$  and volume  $(1 + c) V_2$ . To be strictly accurate, we should also take into account the volume of the equalisation valve; but this is comparatively small, and may be neglected. The pressure then becomes  $p_3$ , as shown at L and C, and admission commences when the expansion curve L H is completed—*i.e.*, at the point H of the stroke when the pressure has fallen to  $p_2$ . The volumetric efficiency is

$$\eta_3 = \frac{D H}{C L}$$

and is evidently greater than that in fig. 2. Assuming, first, that compression, equalisation, and expansion are isothermal,

$$p_1 c + p_2 (1 + c) = p_3 (1 + 2 c)$$

so that if N is the number of atmospheres to which the air is compressed,

$$p_3 = p_2 \frac{1 + (1 + N) c}{1 + 2 c} \dots \dots \dots (14)$$

$$G H = c V_2 \frac{p_3}{p_2} = c V_2 \frac{1 + (1 + N) c}{1 + 2 c}$$

and

$$\begin{aligned} \eta_3 &= \frac{G D - H G}{L C} = 1 + c - c \frac{1 + (1 + N) c}{1 + 2 c} \\ &= \frac{1 + 2 c - (N - 1) c^2}{1 + 2 c} = 1 - \frac{(N - 1) c^2}{1 + 2 c} \dots \dots (15) \end{aligned}$$

Next let us suppose that compression, etc., take place adiabatically; then, during equalisation of pressure, the



intrinsic energy of the two quantities of air that mix remains unchanged. Now, the intrinsic energy of a pound of air is  $K_v t$  where  $t$  is its absolute temperature, and  $K_v$  its capacity for heat at constant volume; hence, if  $V$  and  $p$  are volume and pressure of any weight of gas, its intrinsic energy

$$I = \frac{p V}{R} K_v.$$

Therefore

$$\frac{p_3 V_2 (1 + 2c) K_v}{R} = \frac{p_1 c V_2 K_v}{R} + \frac{p_2 V_2 (1 + c) K_v}{R}$$

or

$$p_3 V_2 (1 + 2c) = p_1 c V_2 + p_2 V_2 (1 + c)$$

or  $p_3$  has the same value as in (14).

But  $LH$  is now an adiabatic, and

$$p_3 (cV_2)^\gamma = p_2 GH^\gamma$$

$$\begin{aligned} \eta_3 &= \frac{DH}{LC} = \frac{GD - GH}{LC} = 1 + c - c \left( \frac{p_3}{p_2} \right)^{\frac{1}{\gamma}} \\ &= 1 + c - c \left\{ \frac{1 + (1 + N)c}{1 + 2c} \right\}^{\frac{1}{\gamma}} \dots (16) \end{aligned}$$

*Numerical Example.*—To calculate  $p_3$  and  $\eta_3$  for a cylinder volume of 1 cubic foot, a clearance of one-fifth of a cubic foot, and compression to four atmospheres.

In any case, from (14),

$$p_3 = 14.7 \frac{1 + 5 \times \frac{1}{5}}{1^{\frac{2}{5}}} = 21 \text{ lb.}$$

For isothermal compression, from (15),

$$\eta_3 = 1 - \frac{3 \times \frac{1}{2.5}}{1^{\frac{2}{5}}} = \frac{32}{35} = 91.4 \text{ per cent.}$$

With adiabatic compression, from (16),

$$\eta_3 = 1\frac{1}{5} - \frac{1}{5} \left\{ \frac{1 + 5 \times \frac{1}{5}}{1^{\frac{2}{5}}} \right\}^{\frac{1}{\gamma}} = 94.3 \text{ per cent.}$$

6. *Work Done per Stroke with Equalisation of Pressure.*—This is represented by the area ABCDHL, and

$$ABCDHL = MBCK + KCDG - KLAM - KLHG.$$

First, assuming isothermal compression, the above

$$= U = 144 V_2 \left\{ (1 + c) (p_3 \text{ hyp. log } \frac{p_1}{p_3} + p_3 - p_2) - (p_1 - p_3) c - p_3 c \text{ hyp. log } \frac{p_3}{p_2} \right\} \quad (17)$$

Using (14), the above may be put in terms of  $p_1$  and  $p_2$ ,  $p_3$  being eliminated, but it is then very complicated, and we prefer to leave it in the above form.

If the compression is adiabatic, we get

$$U = 144 V_2 \left\{ (1 + c) \left( \frac{\gamma}{\gamma - 1} p_3 \left[ \left( \frac{p_1}{p_2} \right)^{\frac{\gamma-1}{\gamma}} - 1 \right] + p_3 - p_2 \right) - (p_1 - p_3) c - \frac{\gamma}{\gamma - 1} p_2 c \left( \frac{p_3}{p_2} \right)^{\frac{1}{\gamma}} \left[ \left( \frac{p_3}{p_2} \right)^{\frac{\gamma-1}{\gamma}} - 1 \right] \right\} \quad (18)$$

*Numerical Example.*—To find the work required per stroke when the cylinder volume is 1 cubic foot, the clearance one-fifth of a cubic foot, and the compression to four atmospheres.

First, assuming isothermal compression from (17) and (14),

$$\begin{aligned} U &= 144 \left\{ 1\frac{1}{5} \times (21 \text{ hyp. log } \frac{58.8}{21} + 6.3) - 37.8 \times \frac{1}{5} \right. \\ &\quad \left. - \frac{2.1}{5} \text{ hyp. log } \frac{21}{14.7} \right\} \\ &= 144 \left\{ 1\frac{1}{5} (21.6 + 6.3) - 7.56 - 1.5 \right\} \\ &= 3860 \text{ foot-pounds.} \end{aligned}$$

The volumetric efficiency has been shown to be 91.4 per cent, so that the air efficiency

$$\eta_2 = \frac{2931 \times 91.4}{3860} = 69.5 \text{ per cent.}$$

The low efficiency is, of course, due to the somewhat large clearance.

With adiabatic compression, from (18),

$$U = 144 \left\{ 1.2 \left( 3.45 \times 21 \left[ \left( \frac{58.8}{21} \right)^{29} - 1 \right] + 6.3 \right) - \frac{37.8}{5} - \frac{3.45 \times 14.7}{5} \times \left( \frac{21}{14.7} \right)^{71} \left[ \left( \frac{21}{14.7} \right)^{29} - 1 \right] \right\} \\ = 4500 \text{ foot-pounds.}$$

The air efficiency is here

$$= \frac{2931 \times .943}{4500} = 61.5 \text{ per cent,}$$

so that our statement above, that increased volumetric efficiency produces a loss of air efficiency, is corroborated.

7. *Rise of Temperature during Compression and the Quantity of Heat that must be Withdrawn.*—Let  $p v^n =$  constant be the equation of the compression curve,  $n$  being, of course, greater than unity and less than  $\gamma$ . Then, since

$$p_1 v_1^n = p_2 v_2^n \text{ and } \frac{p_1 v_1}{t_1} = \frac{p_2 v_2}{t_2}$$

subscript 2 referring to the commencement, and 1 to the end of the compression curve, such as CB, fig. 1,

$$\frac{t_1}{t_2} = \left( \frac{p_1}{p_2} \right)^{\frac{n-1}{n}}$$

and equation (4) gives us per pound

$$H_1 = U_o - K_v (t_1 - t_2) \quad . \quad . \quad (4)$$

Here  $U_o$  is the work done during compression = GBCD, fig. 1 ;

$$\therefore U_o = \frac{144 (p_1 v_1 - p_2 v_2)}{n - 1} \\ = \frac{R (t_1 - t_2)}{n - 1} \text{ per lb.}$$

so that  $H_1 = 144 \frac{p_1 v_1 - p_2 v_2}{R (n - 1)} \left\{ R - K_v (n - 1) \right\} \quad . \quad (19)$

when the volume is known, or

$$H_1 = \frac{t_1 - t_2}{n - 1} \left\{ R - K_v (n - 1) \right\} \quad (20)$$

per pound of air,  $R = 53.2$ , and  $K_v = 130.15$  foot-pounds.

Equation (19) may also be put in the form

$$H_1 = 144 \frac{p_2 v_2}{n - 1} \left\{ \left( \frac{p_1}{p_2} \right)^{\frac{n-1}{n}} - 1 \right\} \left\{ \frac{R - K_v (n - 1)}{R} \right\} \quad (21)$$

It may be mentioned here that where air is used to burn fuel the weight is the quantity that should be known, but when used for transmission of power, the volume.

With equalisation of pressure at the end of the stroke, the quantity of heat that must be withdrawn is given by (21) if  $p_3$  is substituted for  $p_2$ .

*Numerical Example.*—The clearance volume is one-fifth of a cubic foot, and that of the cylinder 1 cubic foot; the compression is four atmospheres, and the exponent  $n$  is 1.25. To find  $H_1$  in foot-pounds per stroke.

Here  $v_2 = V_2 (1 + c) = 1.2$  cubic feet, so that

$$H_1 = 144 \times \frac{14.7 \times 1.2}{.25} \left\{ 4^2 - 1 \right\} \left\{ \frac{53.2 - 130.15 \times .25}{53.2} \right\}$$

$$= 1265 \text{ foot-pounds.}$$

The temperature  $t_1$  absolute at the end of compression is

$$t_1 = t_2 \left( \frac{p_1}{p_2} \right)^{\frac{n-1}{n}} = 521 \times 4^2 = 686 \text{ absolute}$$

$$= 225 \text{ Fah.}$$

if the temperature of the atmosphere is 60 Fah.

Had the compression been adiabatic, then

$$t_1 = t_2 \left( \frac{p_1}{p_2} \right)^{\frac{\gamma-1}{\gamma}} = 521 \times 4^{.29} = 775 \text{ absolute}$$

$$= 314 \text{ Fah.}$$

In order to find the highest temperature from an actual diagram equation (1) may be used, because we know the

volumes and pressures of the admitted and discharged air whether there be equalisation of pressure or no. Let  $v_2$  be the volume of air admitted per stroke, which is F C, H C, or H D in figs. 1, 2, and 3 respectively, and if  $v_1$  is the volume of air discharged, it is represented by A B in all three figures. In an actual diagram  $p_4$ , the actual terminal pressure of the suction stroke will be a trifle less than  $p_2$ , but of course it can be obtained by measurement from the diagram. The temperature of the atmosphere is  $t_2$ , so that

$$\frac{t_1}{p_1 v_1} = \frac{t_2}{p_4 v_2} \text{ or } t_1 = \frac{t_2 p_1 v_1}{p_4 v_2} \dots (21)$$

Strictly speaking,  $t_1$  is not the highest temperature, because  $p_1$  is not the highest pressure. In fig. 4, which is an indicator diagram from an air compressor constructed by

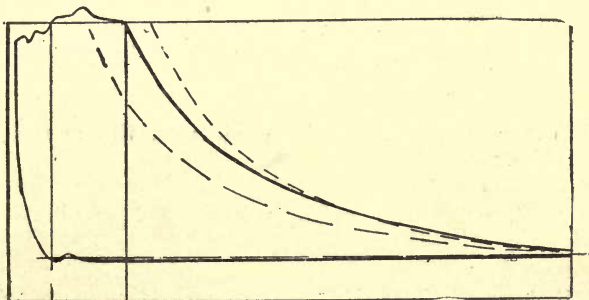

Cylinder, 8 in. bore; 12 in. stroke; revolutions, 140 per minute; I.H.P., 14.7, neglecting friction; air delivered, 93.5 per cent of cylinder capacity; clearance, 1.081 per cent; mechanical efficiency, neglecting friction, 80 per cent.

FIG. 4.

the Tilghman's Patent Sand Blast Co., it will be noticed that the pressure at the end of compression is higher than that at the end of discharge, which latter, of course, is equal to  $p_1$ , and it is the former,  $p_5$ , which must be used in (21); also the volume  $v_5$  at this pressure is really less than  $v$ , and can only be found approximately by producing the curve of expansion from the clearance upwards. Then the horizontal

line between the curves of expansion and compression at a height corresponding to  $p_5$  will give  $v_5$ , so that the highest temperature

$$t_5 = \frac{t_2 p_5 v_5}{p_4 v_2} \dots \dots \dots (22)$$

in place of  $v_1$ ,  $v_2$ , and  $v_5$ , the corresponding lengths on the diagram in inches, would be used.

*Numerical Example.*—In fig. 4 the horizontal distance between the lower end of the expansion curve and the foot of the compression curve is 11 centimetres. This is  $v_2$ , and  $v_5$  is 2.35 centimetres. The pressure  $p_4$  at the end of the suction stroke is 14 lb. per square inch, while the highest pressure on the compression curve is 94.5. Assuming an atmospheric temperature of 60 deg. Fah., then the highest temperature from (22) is

$$t_5 = \frac{521 \times 94.5 \times 2.35}{14 \times 11} = 750 \text{ absolute} \\ = 289 \text{ Fah.}$$

If the compression had been adiabatic, the temperature would have been

$$t_5 = t_2 \left( \frac{p_5}{p_4} \right)^{\frac{\gamma-1}{\gamma}} = 521 \times 6.76^{.29} = 906 \text{ absolute} \\ = 445 \text{ Fah.}$$

8. *Cooling of the Air.*—Equation (6b) shows that it is advantageous to cool the air during admission when the weight of air supplied, and not its volume, is considered, for the work per pound is shown to be proportional to  $t_2$ , which may, in practice, be taken as the temperature at the end of admission. But (6a) shows that for a given volume of atmospheric air cooling during admission is useless. If the air is to be used for driving machinery at a distance, cooling during the discharge is useless, because it does not decrease the work  $144 (p_1 - p_2) v_1$  which is required to expel the air, and the air will be cooled in the pipes during transmission. If the air is to be used at once, to cool it during discharge is wasteful, because it thereby loses some of its intrinsic

energy. It is therefore clear that cooling should take place during compression, and cease as soon as discharge commences. The object, of course, is to reduce  $n$  as near to unity as possible. Much cooling cannot be done during admission unless water much colder than the air can be obtained. In spite of this there are many examples of compressors in which water is injected during the suction stroke.

9. *To Find the Exponent of the Compression Curve.*—If  $p v^n = \text{constant}$ ,

$$\log p_1 + n \log v_1 = \log p_2 + n \log v_2.$$

Hence, on the ideal diagram in which the compression curve lies between  $p_1$  and  $p_2$ ,

$$n = \frac{\log p_1 - \log p_2}{\log v_2 - \log v_1} \dots \dots \dots (23)$$

$v_1$  and  $v_2$  being the final and initial volumes ; so that in fig. 1

$$v_2 = v_2 \text{ and } v_1 = v_1.$$

In figs. 2 and 3,

$$v_2 = V_2(1 + c) \text{ and } v_1 = V_1 + cV_2;$$

so that unless we know  $c$  we cannot use (23). If, however, we assume that the whole compression curve follows the above law, then, if we cannot actually measure the clearance volume, we can calculate it and also  $n$ , with the result that

$$cV_2 = \frac{V_1V_2 - V_6^2}{2V_6^* - V_1 - V_2} \dots \dots \dots (24)$$

$n$  can now be calculated from (23).

*Numerical Example.*—As in the previous example, the pressures at the commencement and end of compression are 14 and 94.5 lb. respectively, while the volumes  $V_1$  and  $V_2$  (neglecting clearance) are represented by 2.35 and 11.8 centimetres ;  $p_6 = \sqrt{p_1 p_2} = 36.3$  absolute, and  $V_6 = 5.35$  centimetres ; to calculate  $n$  and the clearance as a fraction of the cylinder volume,

$$c = \frac{V_1V_2 - V_6^2}{V_2(2V_6 - V_1 - V_2)} = \frac{2.35 \times 11.8 - 5.35^2}{11.8(10.7 - 14.15)}$$

---

\*  $V_6$  is the value of  $V$  when  $p_6 = \sqrt{p_1 p_2}$ ,

= 0.965 per cent, and  $c V_2$  is represented by .11 centimetres. It is given in fig. 4 as 1.081 per cent.

$$n = \frac{\log 94.5 - \log 14}{\log 11.91 - \log 2.46} = 1.21.$$

It is not advisable, however, to trust to the calculated value of  $c$ , as the equation to the curve is not always  $p v^n = \text{constant}$ .

10. *Compound Air Compressors.*—In order to reduce the amount of work and the stresses upon the working parts, compression is effected in two or more stages, the air being cooled in receivers placed between the cylinders. Fig. 5 is a combined diagram of compound compression, neglecting

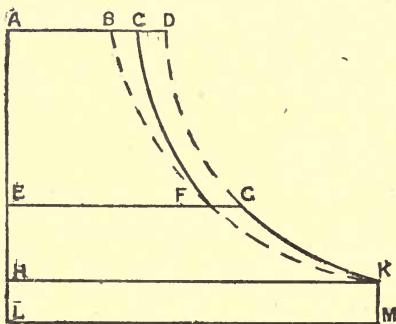

FIG. 5.

clearance; ACFE is the diagram of the high-pressure cylinder, and EGHK that of the low; KFB is an isothermal, and KGD a curve whose equation is  $p v^n = \text{constant}$ , which we shall suppose is the compression curve in a single cylinder compressing to the same pressure. The air is discharged from the low-pressure cylinder with a volume EG into a large receiver, where we suppose its pressure to remain constant while it is cooled to the volume EF at atmospheric temperature. The high-pressure cylinder now draws in this volume and compresses it to the pressure required and the



volume A C. The actual work required is thus represented by the areas A C F E and E G K H; the quantity that would have to be done in a single cylinder is K D A H, so that the work C D G F is saved. The ideal amount of work needed is A B K H. Let  $p_1, v_1$  be the pressure and volume at C,  $p_3, v_3$  those at F, and  $p_2, v_2$  those at K; we shall first find the ratio of E F to H K, that will make the work that is to be done a minimum.

$$E G K H = \frac{144 n}{n - 1} p_2 v_2 \left\{ \left( \frac{p_3}{p_2} \right)^{\frac{n-1}{n}} - 1 \right\} \quad (6a)$$

$$A C F E = \frac{144 n}{n - 1} p_3 v_3 \left\{ \left( \frac{p_1}{p_3} \right)^{\frac{n-1}{n}} - 1 \right\}$$

but  $p_3 v_3 = p_2 v_2$ , as F K is an isothermal; therefore the total work done

$$U = \frac{144 n}{n - 1} p_2 v_2 \left[ \left( \frac{p_3}{p_2} \right)^{\frac{n-1}{n}} + \left( \frac{p_1}{p_3} \right)^{\frac{n-1}{n}} - 2 \right] \quad (25)$$

so that  $\left( \frac{p_3}{p_2} \right)^{\frac{n-1}{n}} + \left( \frac{p_1}{p_3} \right)^{\frac{n-1}{n}}$  must be a minimum.

Let  $p^{\frac{n-1}{n}} = P,$

then  $u = \frac{P_3}{P_2} + \frac{P_1}{P_3}$  must be a minimum.

Differentiating  $u$  with respect to  $P_3$  and equating to 0, we get

$$\frac{d u}{d P_3} = \frac{1}{P_2} - \frac{P_1}{P_3^2} = 0$$

$$\therefore P_3^2 = P_1 P_2$$

or  $p_3^2 = p_1 p_2.$

Let the isothermal B K be  $p v = c.$  Then

$$\frac{c^2}{v_3^2} = \frac{p_1 c^2}{p_2 v_2^2}$$

or  $v_3 = v_2 \sqrt{\frac{p_2}{p_1}} \dots \dots (26)$

or if  $d, D$  are the diameters of the high-pressure and low-pressure cylinders, both of the same stroke,

$$\left. \begin{aligned} d_3^2 &= d_2^2 \sqrt{\frac{p_2}{p_1}} \\ d_3 &= d_2 \sqrt[4]{\frac{p_2}{p_1}} \end{aligned} \right\} \dots \dots \dots (27)$$

Equation (25) now becomes

$$U = \frac{288 n}{n - 1} p_2 v_2 \left[ \left( \frac{p_1}{p_2} \right)^{\frac{n-1}{2n}} - 1 \right] \dots \dots (28)$$

If there are several cylinders, as in fig. 6, and if the intermediate pressures at C and F are  $p_3, p_4$  respectively, then, as we have shown,

$$p_4^2 = p_2 p_3, \text{ and } p_4 p_1 = p_3^2$$

so that  $p_1, p_3, p_4$ , and  $p_2$  are in geometrical progression. Let  $v_3, v_4, v_2$  be the volumes of the cylinders CD, FG, and KL, and let AM be  $v_0$ . Let

$$\frac{p_1}{p_2} = r$$

and therefore

$$\frac{v_2}{v_0} = r$$

then

$$\frac{v_2}{v_4} = \frac{v_4}{v_3} = \frac{v_3}{v_0} = K$$

$$\frac{v_2 v_4 v_3}{v_4 v_3 v_0} = K^3 = r$$

or

$$K = \sqrt[3]{r}$$

therefore

$$\frac{v_2}{v_4} = \sqrt[3]{r}$$

or

$$\frac{v_4}{v_2} = \left( \frac{p_2}{p_1} \right)^{\frac{1}{3}}$$

$$\frac{v_3}{v_2} = \left( \frac{p_2}{p_1} \right)^{\frac{2}{3}}$$

and if the diameter of the high-pressure cylinder is  $d_3$ , and that of the intermediate  $d_4$ , then

$$\left. \begin{aligned} d_4 &= d_2 \left( \frac{p_2}{p_1} \right)^{\frac{1}{6}} \\ d_3 &= d_2 \left( \frac{p_2}{p_1} \right)^{\frac{1}{3}} \end{aligned} \right\} \dots \dots \dots (29)$$

*Numerical Example.*—A compound air compressor has a low-pressure cylinder whose diameter is 24 in., the strokes of both high and low pressure pistons are 2 ft., and the number of revolutions per minute is 140. The air is compressed to 7 atmospheres. Assuming that  $n = 1.25$ , neglecting clearance, and assuming a volumetric efficiency of 95 per cent, to find the diameter of the high-pressure cylinder and the horse power.

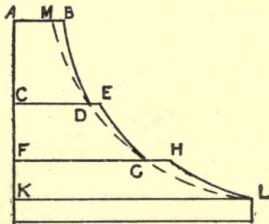

FIG. 6.

The diameter of the high-pressure cylinder is

$$d_3 = 24 \times \sqrt[4]{\frac{1}{7}} = 14.7 \text{ in.}$$

and  $p_3 = \sqrt{p_1 p_2} = 14.7 \sqrt{7} = 38.8 \text{ lb.}$

The work per stroke, with .95 volumetric efficiency, is given by (28).

$$\begin{aligned} U &= \frac{1.25}{.25} \times 14.7 \times \frac{\pi}{4} \times 24^2 \times 2 \left[ 7^{\frac{1}{1.25}} - 1 \right] \times 2 \times .95 \\ &= 27000 \text{ foot-pounds.} \end{aligned}$$

$$\text{The horse power} = \frac{27000 \times 280}{33000} = 229.$$

Of course the indicated horse power of the steam cylinders is more than this, as friction has to be overcome.

The ratio of the work done, neglecting clearance, in a compound compressor to that in a simple compressor can be obtained from (28) and (6a). Dividing the former by the latter, we obtain

$$\begin{aligned} R &= \frac{2 \left\{ \left( \frac{p_1}{p_2} \right)^{\frac{n-1}{2n}} - 1 \right\}}{\left( \frac{p_1}{p_2} \right)^{\frac{n-1}{n}} - 1} \\ &= \frac{2}{\left( \frac{p_1}{p_2} \right)^{\frac{n-1}{n}} + 1} \quad \dots \quad (30) \end{aligned}$$

In the above example this is

$$R = \frac{2}{2 \cdot 214} = \cdot 9.$$

The improved volumetric efficiency of a compound compressor is evident. For example, if we assume a clearance of  $\frac{1}{20}$ , the volumetric efficiency for a simple compressor would be, from (13),

$$\begin{aligned} \eta_3 &= 1 + c - c \left( \frac{p_1}{p_2} \right)^{\frac{1}{n}} = 1 \cdot 05 - 7^{\frac{1}{8}} \times \frac{1}{20} \\ &= 1 \cdot 050 - \cdot 237 = \cdot 813. \end{aligned}$$

In the compound air compressor the highest pressure in the low-pressure cylinder is  $p_2 \sqrt[4]{7}$ , because the compression is to 7 atmospheres; hence

$$\eta_3 = 1 \cdot 05 - 7^{\frac{1}{4}} \times \frac{1}{20} = \cdot 941.$$

*Numerical Example.*—Air is to be compressed to 200 atmospheres in three stages. To find the work required per

cubic foot of atmospheric air, supposing the compression in each cylinder is adiabatic. Also to find the horse power and diameters of cylinders, if that of the low-pressure cylinder is 25 in., the stroke 30 in., and revolutions per minute 90, the volumetric efficiency being 85 per cent.

$$\left(\frac{p_1}{p_2}\right)^{\frac{1}{3}} = \sqrt[3]{200} = 5.848$$

$$d_4 = \frac{d_2}{\sqrt{5.848}} = \frac{25}{2.42} = 10.32 \text{ in.}$$

$$d_3 = \frac{d_2}{5.848} = 4.27 \text{ in.}$$

The formula for the work required is obtained in the same way as (28), and is

$$U = 3 \times 144 \frac{n}{n-1} p_2 v_2 \left\{ \left(\frac{p_1}{p_2}\right)^{\frac{n-1}{3n}} - 1 \right\}. \quad (31)$$

and if  $n = \gamma$ , this becomes, if  $v_2 = 1$  cubic foot,

$$\begin{aligned} U &= 3 \times 144 \times 3.44 \times 14.7 \left\{ 5.848^{\frac{29}{3}} - 1 \right\} \\ &= 14800 \text{ foot-pounds.} \end{aligned}$$

The number of cubic feet of atmospheric air per minute is

$$\frac{\pi}{4} \times \frac{25^2}{144} \times 2\frac{1}{2} \times 180 \times \frac{85}{100} = 1300$$

so that the horse power required, exclusive of that needed to overcome friction, is

$$\text{H.P.} = \frac{14800 \times 1300}{33000} = 582.$$

And as each cylinder requires the same amount of power, the horse power of each will be 194.

In this case the ratio of the work actually done to that which would be required in a simple engine is

$$R = \frac{3 \left\{ \left( \frac{p_1}{p_2} \right)^{\frac{\gamma-1}{3\gamma}} - 1 \right\}}{\left( \frac{p_1}{p_2} \right)^{\frac{\gamma-1}{\gamma}} - 1} \dots (32)$$

$$= \frac{3 \{ 5.848^{.29} - 1 \}}{200^{.29} - 1} = .439.$$

11. *Ratios of Cylinders, taking Clearance into Account.*—When clearance is taken into account the volume compressed in any cylinder is H C, fig. 2, and

$$H C = \left\{ 1 + c - c \left( \frac{p_1}{p_2} \right)^{\frac{1}{n}} \right\} V_2.$$

Fig. 7 is the combined diagram of a three-stage air compressor, and the volumes A B, C D, E F correspond to

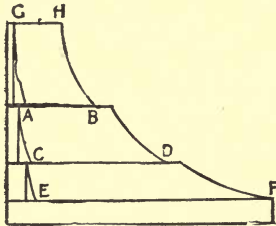

FIG. 7.

H C in fig. 2. In one revolution no work is done on the air that is compressed into the clearance space and expands again; in fact, the work done in each of the three cylinders is the same as that which would be done in cylinders without clearance and having volumes A B, C D, E F. If we give these volumes the same ratios as in section 10, we shall have the most economical cylinder ratios. Let the pressures at

AB and CD be  $p_3$  and  $p_4$ , and the cylinder volumes of the high-pressure and intermediate cylinders  $V_3$  and  $V_4$ . Let the clearance ratios be  $c_3$ ,  $c_4$ , and  $c_2$ . As in section 10,  $p_1$ ,  $p_3$ ,  $p_4$ , and  $p_2$  are in geometrical progression, and therefore

$$\frac{p_4}{p_2} = \frac{p_3}{p_4} = \frac{p_1}{p_3} = \left(\frac{p_1}{p_2}\right)^{\frac{1}{3}}$$

and

$$\frac{EF}{CD} = \frac{CD}{AB} = \frac{AB}{GH} = \sqrt[3]{\frac{p_1}{p_2}}$$

$$\begin{aligned} \therefore \frac{\left\{ 1 + c_2 - c_2 \left(\frac{p_1}{p_2}\right)^{\frac{1}{3n}} \right\} V_2}{\left\{ 1 + c_4 - c_4 \left(\frac{p_1}{p_2}\right)^{\frac{1}{3n}} \right\} V_4} &= \frac{\left\{ 1 + c_4 - c_4 \left(\frac{p_1}{p_2}\right)^{\frac{1}{3n}} \right\} V_4}{\left\{ 1 + c_3 - c_3 \left(\frac{p_1}{p_2}\right)^{\frac{1}{3n}} \right\} V_3} = \sqrt[3]{\frac{p_1}{p_2}}. \end{aligned}$$

Supposing all three pistons have the same stroke,

$$d_4 = d_2 \sqrt[6]{\frac{p_2}{p_1}} \frac{\sqrt{1 + c_2 - c_2 \left(\frac{p_1}{p_2}\right)^{\frac{1}{3n}}}}{\sqrt{1 + c_4 - c_4 \left(\frac{p_1}{p_2}\right)^{\frac{1}{3n}}}} \dots \quad (33)$$

and

$$d_3 = d_2 \sqrt[3]{\frac{p_2}{p_1}} \frac{\sqrt{1 + c_2 - c_2 \left(\frac{p_1}{p_2}\right)^{\frac{1}{3n}}}}{\sqrt{1 + c_3 - c_3 \left(\frac{p_1}{p_2}\right)^{\frac{1}{3n}}}} \dots \quad (34)$$

The following table\* gives the horse power required to compress 1 cubic foot per minute, both isothermally and

\* Air Compressor Catalogue of the Worthington Pump Company.

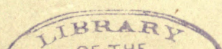

Gauge pressures.	Atmospheres.	Isothermal compression.	Adiabatic compression.			Two-stage compression.			Three-stage compression.		
		H. P. required to compress 1 cubic foot per minute.	H. P. required to compress 1 cubic foot free air per minute.	Efficiency as compared to isothermal.	Final temperature. Degrees Fahrenheit.	H. P. required to compress 1 cubic foot free air per minute.	Efficiency as compared to isothermal.	Final temperature. Degrees Fahrenheit. Normal inter-cooling.	H. P. required to compress 1 cubic foot free air per minute.	Efficiency as compared to isothermal.	Final temperature. Degrees Fahrenheit. Normal inter-cooling.
5	1.34	.0188	.0197	.96	106						
10	1.68	.0333	.0361	.93	145						
15	2.02	.0481	.0505	.90	178						
20	2.36	.0551	.063	.88	207						
25	2.70	.0637	.075	.85	234						
30	3.04	.0713	.085	.84	252						
35	3.38	.0781	.095	.82	281						
40	3.72	.0843	.104	.81	302						
45	4.06	.0900	.112	.80	321						
50	4.40	.0945	.120	.79	339	.109	.87	188			
55	4.74	.0995	.128	.78	357	.115	.87	196			
60	5.08	.1027	.134	.77	375	.121	.86	203			
65	5.42	.1080	.141	.76	389	.126	.86	209			
70	5.76	.1120	.148	.75	405	.131	.85	214			
75	6.10	.1160	.154	.75	420	.136	.85	219			
80	6.44	.1196	.160	.74	432	.141	.85	224			
85	6.78	.1230	.166	.74	441	.146	.84	229			
90	7.12	.1260	.171	.74	459	.150	.84	234			
95	7.46	.1290	.176	.73	472	.154	.84	239			
100	7.80	.1320	.182	.73	485	.158	.83	243			
110	8.48	.1371	.192	.72	501	.165	.83	250			
120	9.16	.1422	.202	.71	529	.172	.83	257			
130	9.84	.1467	.210	.70	560	.179	.82	265			
140	10.52	.1510	.218	.69	570	.186	.82	272			
150	11.20	.1547	.226	.69	589	.193	.81	279	.182	.85	200
160	11.88	.1583	.234	.68	607	.198	.81	285	.187	.85	204
170	12.56	.1622	.242	.67	624	.203	.80	291	.192	.85	207
180	13.24	.1656	.249	.67	640	.208	.80	297	.197	.84	211
190	13.92	.1687	.256	.66	657	.213	.79	303	.202	.84	214
200	14.6	.1720	.263	.65	672	.217	.79	309	.206	.83	218
225	16.4	.1790	.273	.64	715	.227	.79	320	.215	.83	224
250	18	.1860	.282	.64	749	.237	.78	331	.224	.83	230
275	19.7	.1920	.306	.63	780	.247	.78	342	.233	.82	236
300	21.4	.1970	.317	.62	815	.256	.77	352	.241	.82	241
325	23.1	.2020	.328	.61	837	.264	.77	361	.247	.82	246
350	24.8	.2060	.342	.60	867	.272	.76	370	.252	.82	250
375	26.5	.2100	.354	.59	892	.277	.76	375	.257	.82	254
400	27.2	.2140	.364	.59	915	.283	.76	380	.262	.82	258
450	31.7	.2230	.381	.58	960	.295	.75	397	.272	.82	266
500	35	.2290	.395	.57	1001	.307	.75	413	.282	.81	274



adiabatically, in one, two, and three stages, with the efficiency in the latter case compared with isothermal compression, and the final temperature reached. For example, with 100 lb. gauge pressure the efficiency in single-stage compression is 73 per cent, and in two-stage 83, while the temperatures are 485 Fah. and 243 Fah.

12. *On the Loss of Pressure during Transmission in a Straight Pipe of Uniform Diameter.*—Let  $V_1$  be the velocity with which the air enters the pipe, and  $V_2$  that of discharge. Let  $L$  be the total length, and  $D$  the diameter of the pipe, both in feet. Let the pressures at A, B, C, D be  $p_1, p_2, p,$  and  $p + dp$  in pounds per square inch;  $dp$  is of course a

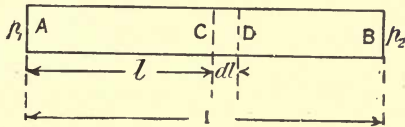

FIG. 8.

negative quantity. Let the specific volumes at the same points be  $v_1, v_2, v,$  and  $v + dv$ , and the velocities at C and D be  $V$  and  $V + dV$ . The loss of head—*i.e.*, of energy in foot-pounds per pound of air—due to friction for a small length  $dl$  of the pipe between C and D, fig. 8, is

$$h = f \frac{4 dl}{D} \frac{V^2}{2g}$$

In "The Development and Transmission of Power," Professor Unwin gives

$$f = .0027 \left( 1 + \frac{3}{10 D} \right)$$

so that

$$h = k dl \frac{V^2}{2g}$$

where

$$k = \frac{.0108}{D} \left( 1 + \frac{3}{10 D} \right) \dots \dots (33)$$

Let  $\rho$  be the density of the air at C, then

$$V \rho = \frac{V}{v} = \text{constant} = \frac{V_1}{v_1} = \frac{1}{m}.$$

Since the velocity of flow increases, the increased kinetic energy must be due to the work done by the air as it expands from a volume  $v$  to  $v + dv$ , and this work has also to overcome friction. The equation of energy is therefore

$$144 p dv = \frac{V dV}{g} + \frac{k dl V^2}{2g}$$

but 
$$dv = \frac{v_1}{V_1} dV = m dV.$$

Let  $144 p = P$ , the pressure per square foot. Then we may either suppose the expansion to take place isothermally or according to the law  $p v^n = \text{constant}$ . Assuming the former, let  $P v = b$ . Then

$$\frac{b dv}{v} = b \frac{dV}{V} = \frac{V dV}{g} + \frac{k dl V}{2g}$$

$$b \frac{dV}{V^2} = \frac{dV}{g V} + \frac{k dl}{2g}$$

$$c - \frac{b}{2 V^2} - \frac{1}{g} \text{hyp. log } V = \frac{k l}{2g}$$

$$b \left\{ \frac{1}{2 V_1^2} - \frac{1}{2 V_2^2} \right\} - \frac{1}{g} \text{hyp. log } \frac{V_2}{V_1} = \frac{k L}{2g}$$

or 
$$\frac{m^2}{2b} \left\{ P_1^2 - P_2^2 \right\} - \frac{1}{g} \text{hyp. log } \frac{p_1}{p_2} = \frac{k L}{2g}$$

which reduces to

$$k L = \frac{20736 m^2 g}{b} \left\{ p_1^2 - p_2^2 \right\} - 2 \text{hyp. log } \frac{p_1}{p_2}. \quad (3b)$$

If we suppose the flow adiabatic, then

$$P v^\gamma = c \text{ or } P = \frac{c}{v^\gamma}$$

and the equation of energy becomes

$$\frac{c d v}{v^\gamma} = \frac{V d V}{g} + \frac{k d l V^2}{2 g}$$

$$\frac{2 g c d V}{m^{\gamma-1} V^{\gamma+2}} - \frac{2 d V}{V} = k d l.$$

$$k l = C - \frac{2 g c}{(\gamma + 1) m^{\gamma-1} V^{\gamma+1}} - 2 \text{ hyp. log } V.$$

$$k L = \frac{2 g c}{(\gamma + 1) m^{\gamma-1}} \left\{ \frac{1}{V_1^{\gamma+1}} - \frac{1}{V_2^{\gamma+1}} \right\} - 2 \text{ hyp. log } \frac{V_2}{V_1}$$

$$= \frac{2 g m^2}{(\gamma + 1) \cdot \gamma} \left\{ P_1^{\frac{\gamma+1}{\gamma}} - P_2^{\frac{\gamma+1}{\gamma}} \right\} - \frac{2}{\gamma} \text{ hyp. log } \frac{p_1}{p_2}$$

$$k L = \frac{4010 g m^2}{c^{\gamma-1}} \left\{ p_1^{1.7} - p_2^{1.7} \right\} - 1.42 \text{ hyp. log } \frac{p_1}{p_2} \dots (36)$$

*Numerical Example.*—A pipe is 1,000 ft. long, and air enters it at a pressure of 100 lb. per square inch, and is discharged at 90 lb. Its velocity at inflow is 80 ft. per second; what must the diameter of the pipe be?

First let us assume a temperature of 60 deg. Fah., or 521 absolute.

$$P v = R t = b = 53.2 \times 521 = 27700$$

and since

$$P_1 = 14400, v_1 = \frac{27700}{14400} = 1.92$$

$$m = \frac{r_1}{V_1} = \frac{1.92}{80} = \frac{1}{41.6}$$

so that (35) becomes

$$1000 k = \frac{20736 \times 32}{27700 \times (41.6)^2} \left\{ 100^2 - 90^2 \right\} - 4.6 \log \frac{10}{9}$$

$$= 26.2 \text{ nearly.}$$

$$k = .0262 = \frac{.0108}{D} \left( 1 + \frac{3}{10 D} \right)$$

Calling  $x = \frac{1}{D}$ , we have the quadratic,

$$\frac{3}{10}x^2 + x - 2.425 = 0$$

$$x = \frac{9.7}{6} \text{ and } D = .62 \text{ ft.} = 7.42 \text{ in.}$$

If we assume adiabatic expansion, and that the air enters the pipe with a temperature of 750 absolute Fah., then

$$v_1 = \frac{R t}{P_1} = \frac{53.2 \times 750}{14400} = 2.77$$

$$m = \frac{2.77}{80} = \frac{1}{28.9} \text{ and } c = P_1 v_1^\gamma$$

$$= 14400 \times 2.77^{1.408}$$

$$= 60400, \therefore c^{\frac{1}{\gamma}} = 2512, \text{ and (35) gives us}$$

$$1000 k = \frac{4010 \times 32}{(28.9)^2 \times 2512} \left\{ 100^{1.7} - 90^{1.7} \right\} - 3.26 \log \frac{10}{9}$$

$$k = .0183; D = .81 \text{ ft.} = 9.72 \text{ in.}$$

The loss of head at a bend is

$$h = \left\{ 0.131 + 1.847 \left( \frac{D}{2C} \right)^{\frac{7}{2}} \right\} \frac{\phi}{180} \cdot \frac{V^2}{2g}$$

where C is the mean radius of the bend and  $\phi$  the angle of bend in degrees; so that the equivalent length of straight pipe is

$$\frac{\left\{ 0.131 + 1.847 \left( \frac{D}{2C} \right)^{\frac{7}{2}} \right\} \frac{\phi}{180}}{\frac{.0108}{D} \left( 1 + \frac{3}{10} D \right)} \dots (37)$$

## CHAPTER II.

## EXPERIMENTS WITH COMPRESSORS.

12a. *Experiments with Compressors.—Test of a Reumaux Compressor with Mechanically-controlled Valves.\**—This engine had two steam and two compressing cylinders. The diameter of the former was 700 mm. (27·6 in.), and of the latter 620 mm. (24·4 in.), the stroke being 1,600 mm. (63 in.). Experiments were made at 19, 26, 40, and 54 revolutions per minute, the results of which, converted into British units, are given in the following table:—

Revolutions per minute .....	19	26	40	54
Indicated horse power of steam cylinders ..	206	285	481	671
Indicated horse power of compressing cylinders .....	183	254	386	525
Mechanical efficiency per cent .....	88·7	88·8	80·3	78·3
Piston speed in feet per minute .....	198·5	273·5	420	566

In the third experiment the steam and air pressures were 85·2 lb. by gauge, or 99·9 absolute. The piston area is 2,941 square centimetres (456 square inches) on both sides as the piston rod passes right through the compressing cylinder, so that the piston displacement in cubic feet per minute—

$$V_2 = \frac{456}{144} \times 420 = 1327 \text{ per cylinder.}$$

The suction pressure is slightly below that of the atmosphere, and the air expands from the clearance before fresh air is admitted, so that the volumetric efficiency is 94 per cent. This enables us to calculate the ideal horse power.

$$U = \frac{2 \times .94 \times 144 p_2 V_2 \text{ hyp. log } \frac{p_1}{p_2}}{33000}$$

$$= \frac{2 \times .94 \times 144 \times 14.7 \times 1327 \times 2.3 \log \frac{99.9}{14.7}}{33000} = 307.$$

\* Portefeuille economique d. mach., vol. xii., pages 83 and 84.

The total efficiency is therefore

$$\eta_1 = \frac{307}{481} = 64 \text{ per cent,}$$

and the efficiency of compression is

$$\eta_2 = \frac{307}{386} = 79.5 \text{ per cent.}$$

In this compressor water was sprayed into the cylinder. The efficiency of compression with adiabatic compression is 74 per cent, so that the spray had some slight effect.

*Tests of a Straad Compressor with Mechanically-controlled Valves.*\*—The leading dimensions of this engine were:—

Diameter of high-pressure steam cylinder .....	550 mm. (21.7 in.)
Diameter of low-pressure steam cylinder .....	800 mm. (31.55 in.)
Diameter of high-pressure air cylinder .....	400 mm. (15.75 in.)
Diameter of low-pressure air cylinder .....	650 mm. (25.6 in.)
Stroke .....	1000 mm. (39.4 in.)
Steam pressure by gauge .....	118 lb.
Mean revolutions per minute .....	50
Maximum revolutions per minute .....	75
Normal air pressure absolute .....	7 atmospheres.
Maximum air pressure absolute .....	9 atmospheres.

The experiments were carried out by Professor Schröter and Gutermuth during the commencement of 1892, at the Offenbach Power Station. The results are given by them in the following table. We have added the total efficiency and the air efficiency.

Barometer in atmospheres .....	1.03	1.02	1.02	1.02
Intermediate reservoir in atmospheres .....	2.88	2.82	2.90	2.77
Pressure pipes in atmospheres .....	7.12	7.10	8.62	7.10
Temperatures in degrees Cen. in suction pipes .....	6	5.2	3.2	14.9
High-pressure pipe .....	{ Front .... 26.7	{ 24.1	{ 30.2	{ 30.4
	{ Back .... 40.6	{ 38.9	{ 50.3	{ 41.7
Chevaux vapeur* in air cylinders .....	162.45	162.16	180.78	232.88
Revolutions per minute .....	50	50.1	50.7	70.7
Steam pressure by gauge .....	106.5	107	105.6	104.1
I. H. P. of steam cylinders .....	197.24	195.34	213.66	275.24
Feed water in pounds per H. P. hour .....	15.75	17.05	16.00	16.80
Jacket drain in per cent of feed water .....	9.6	12.3	12.0	10.6
Mechanical efficiency, per cent .....	82.4	83	84.6	84.6
Volumetric efficiency in { Front .... .975	{ .974	{ .973	{ .974	
	{ Back .... .967	{ .970	{ .966	{ .965
	{ Average .. .971	{ .972	{ .969	{ .969
L. P. air cylinder .....				
Cubic feet of free air per minute .....	1,120	1,122	1,133	1,580
Total efficiency $\eta_1$ per cent .....	72.6	73.4	74.4	73.25
Air efficiency $\eta_2$ per cent .....	88	88.5	88	86.6

\* One cheval vapeur is .985 of a horse power.

*Tests of a Riedler Compressor at the Central Power Station, Rue St. Fargeau, Paris.* †—The results of four experiments with this compressor are given in the following table. The valves were mechanically controlled; the diameters of the cylinders were 1,090 mm. and 670 mm. (43 in. and 26·4 in.), with a stroke of 1,200 mm. (47·2 in.):—

Revolutions per minute .....	52	60	38	39
Horse power of air cylinders in chevaux vapeur.	615	709	422	424
Compression pressure in atmospheres absolute..	7·0	7·0	7·0	7·0
Volumetric efficiency, per cent .....	98·5	98·0	98·5	98·5
Volume of free air per revolution, in cubic feet.	77·5	77·0	77·5	77·5
Volume of free air in cubic feet per steam } horse power per hour .....	354	354	376	384
Total efficiency $\eta_1$ per cent .....	74·7	74·7	79·4	81
Air efficiency $\eta_2$ per cent .....	82·5	82·2	88·2	90
Mechanical efficiency, per cent .....	90·6	91·0	90·1	90

We have added the last three lines. The total efficiency

$$\eta_1 = \frac{144 \times 14\cdot7 \times \text{hyp. log } 7}{\cdot985 \times 33000 \times 60} v_2$$

where  $v_2$  = volume of free air per steam horse power per hour.

$$\eta_2 = \frac{144 \times 14\cdot7 \times \text{hyp. log } 7}{\cdot985 \times 33000} \times \frac{V_2 \cdot R}{H}$$

where  $V_2$  = volume of free air per revolution,  $R$  = revolutions per minute,  $H$  = horse power of air cylinders, and the mechanical efficiency is  $\eta_1 \div \eta_2$ .

*Test of a Two-stage Compressor constructed by the Chicago Pneumatic Tool Company.*—The following are the results of a test of a two-stage compressor having steam cylinders 16 in. and 27 in. diameter, air cylinders 24 in. and 14 in., with 18 in. stroke.

† Neue Erfahrungen über die Kraftversorgung von Paris durch Druckluft, von Prof. A. Riedler.

RESULTS OF TESTS of 24 C.S.C. compressor (running condensing). *Duration of run*  $2\frac{1}{2}$  hours. *Readings taken every 15 minutes.* *Date, Jan. 7th, 1903.*

Air cylinder data.	Steam cylinder data.	
Average R.P.M. .... 56.3	Average R.P.M. .... 56.3	
Average receiver pressure .... 78.1	Average M.E.P., H.P. cyl. (Hd.E) 37.4	
Average temp. L.P. intake .... 58.3	Average I.H.P., H.P. cyl. (Hd.E) 19.25	
Average temp. L.P. discharge ... 216.0	Average M.E.P., H.P. cylinder (crank E) ..... 42.8	
Average temp. H.P. intake .... 82.4	Average I.H.P., H.P. cylinder (crank E) ..... 22.0	
Degrees of heat extracted by intercooler ..... 136.6	Total I.H.P., H.P. cylinder .... 41.25	
<hr/>		
Average temp. of discharge (H.P.) 182.2	Average M.E.P., L.P. cyl. (Hd.E) 12.6	
Temp. of air compressed to 78, with no cooling ..... 427.0	Average I.H.P., L.P. cyl. (Hd.E) 19.4	
Total degrees of heat extracted by jackets and intercooler ..... 244.8	Average M.E.P., L.P. cyl. (crank E) 14.55	
<hr/>		
Average M.E.P., H.P. air (Hd.E) 37.0	Average I.H.P., L.P. cyl. (Hd.E) 21.16	
Average I.H.P., H.P. air (Hd.E) 14.6	Total I.H.P., L.P. cylinder ..... 40.56	
Average M.E.P., H.P. air (crank E) ..... 37.9	<hr/>	
Average I.H.P., H.P. air (crank E) ..... 14.9	Total I.H.P., H.P., and L.P. steam cylinder ..... 81.81	
Average I.H.P., H.P. air cylinder 29.5	Quality of steam 97 per cent dry vacuum 26.7 in.	
<hr/>		
Average M.E.P., L.P. air (Hd.E) 18.5	Total weight of condensed steam for $2\frac{1}{2}$ hours ..... 4100	
Average I.H.P., L.P. air (Hd.E) 21.5	Actual steam for I.H.P. per hour $\frac{4100}{81.8 \times 2.5} = 20.09$	
Average M.E.P., L.P. air (crank E) ..... 18.2	Dry steam per I.H.P. per hour $20.09 \times 97$ per cent = 19.487	
Average I.H.P., L.P. air (crank E) ..... 21.2	Mechanical efficiency of compressor $\frac{72.2}{81.81} = 88.2$ per cent.	
Average I.H.P., H.P. air cylinder 42.7		
<hr/>		
Total I.H.P. of H.P. and L.P. air cylinders (29.5—42.7) ..... 72.2		
<hr/>		
Average intercooler gauge pressure 26.7		

The above table shows that the volume swept out by the L.P. piston was 533 cubic feet per minute ; to compress this to 78.1 lb per square inch by gauge or 92.8 absolute would require .88 horse power.



$$U = \frac{14.7 \times 144 \times 533 \times 2.3 \log \frac{92.8}{14.7}}{33000}$$

$$= 63.2.$$

The efficiency of compression

$$\eta_2 = \frac{62.2}{72.2} = 87.2 \text{ per cent,}$$

AIR CYLINDER.

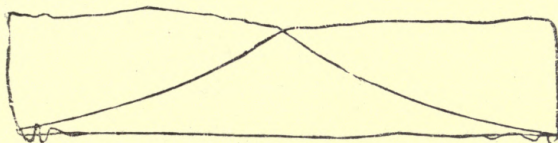

Diameter of cylinder, 11 in.; stroke, 14 in.; R.P.M., 140; M.E.P., 41.6; boiler pressure, 95; air pressure, 100; I.H.P., 39.1.

STEAM CYLINDER.

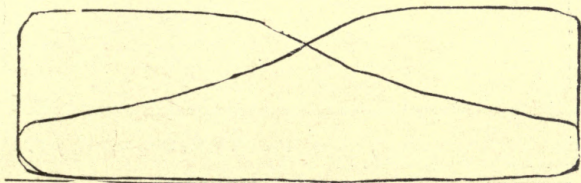

Diameter of cylinder, 12 in.; stroke, 14 in.; R.M.P., 140; M.E.P., 50.7; boiler pressure 95; air pressure, 100; I.H.P., 56.7.

FIG. 9.

and the total efficiency

$$\eta_1 = \frac{62.2}{81.81} = 76 \text{ per cent.}$$

Assuming a volumetric efficiency of 95.25 per cent, as in the next example, these figures reduce to 83 and 72.2 per cent.

Figs. 9 and 10 show the steam and air diagrams of another two-stage air compressor by the same firm. Measurement of the diagrams shows that the volumetric efficiency

## AIR CYLINDER.

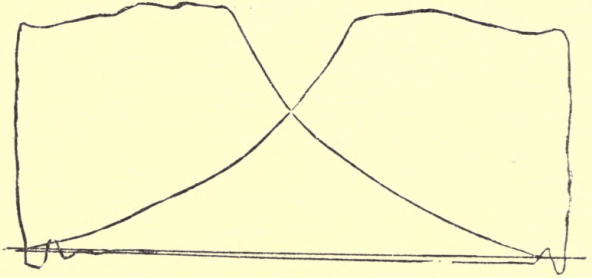

Diameter of cylinder, 19 in. ; stroke, 14 in. ; R.P.M., 140 ; M.E.P., 18.8 ; boiler pressure, 95 ; air pressure, 100 ; I.H.P., 52.9.

## STEAM CYLINDER.

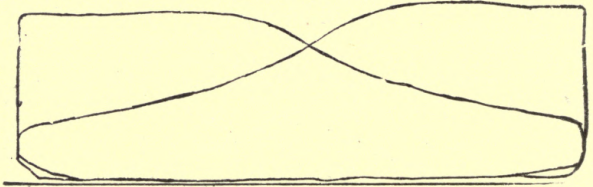

Diameter of cylinder, 12 in. ; stroke, 14 in. ; R.M.P., 140 ; M.E.P., 49.7 ; boiler pressure, 95 ; air pressure, 100 ; I.H.P., 55.6.

FIG. 10

is 95.25 per cent. The ideal mean effective pressure referred to the low-pressure air piston is

$$0.9525 \times 14.7 \text{ hyp. log } \frac{114.7}{14.7} \\ = 28.8.$$

The actual mean pressure is 32.75.

$$\text{Hence } \eta_2 = \frac{28.8}{32.75} = 88 \text{ per cent.}$$

The mechanical efficiency is

$$\eta = \frac{92}{112.3} = 82 \text{ per cent.}$$

The total efficiency is therefore 72.1 per cent.

The values of the exponents  $n$  for low-pressure and high-pressure diagrams are 1.29 and 1.33.

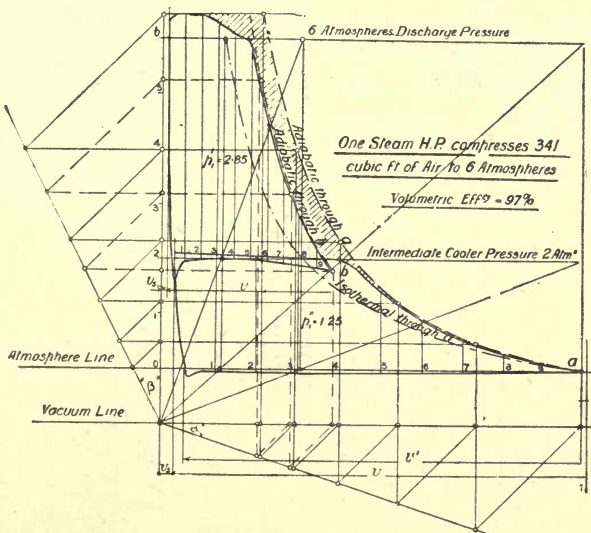

FIG. 11.

*Test of a Two-stage Compressor Constructed by Messrs. Breitfeld, Danek, and Co., of Prague, Karolinenthal.*—The combined diagram of the compression cylinders is shown in fig. 11, for which I am indebted to the above firm. The diameters of the steam cylinders are 675 mm. and 950 mm. (26.6 in. and 37.45 in.), the blowing cylinders are 530 mm. and 875 mm. (20.9 in. and 34.5 in.), and the stroke is 900 mm. (35.5 in.) The engine is condensing, the admission pressure 88 lb. by gauge, and the air is compressed to 7

atmospheres absolute. The speed was 68 revolutions per minute, and the mechanical efficiency 88 per cent. The mean effective pressures of the high and low pressure compressing cylinders were 2·85 and 1·25 atmospheres, and the mean effective pressure referred to the low-pressure piston was 2·39 atmospheres. The volumetric efficiency was 97 per cent, so that the mean effective pressure referred to the low-pressure piston with isothermal compression would have been

$$p = \cdot 97 \times \text{hyp. log } 7 = 1\cdot885 \text{ atmospheres.}$$

The efficiency of compression and the total efficiency are

$$\eta_2 = \frac{1\cdot885}{2\cdot39} = 79 \text{ per cent; } \eta_1 = 79 \times \cdot 88 = 69\cdot5 \text{ per cent.}$$

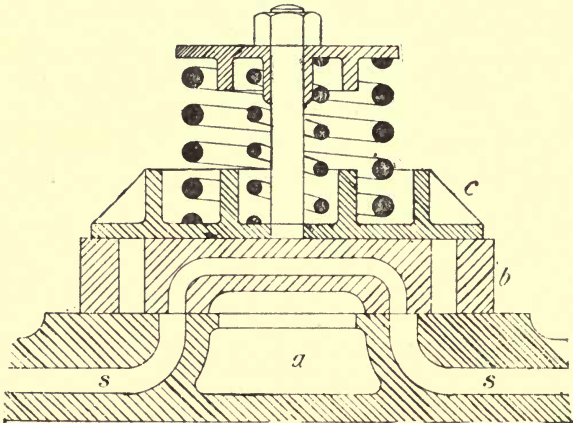

FIG. 12.

These experiments were made on the 20th and 21st of June, 1903. On the former the temperature of the entering air was between 27 deg. Cen. and 29 deg. Cen.; that of the air entering the intermediate cooler between 115 deg. and 136 deg., which fell to between 50 deg. and 57 deg. on leaving it.

The discharge temperature was from 124 deg. to 146 deg., and the rise of temperature of the cooling water was from  $6\frac{1}{2}$  deg. to 10 deg.

### CHAPTER III.

#### VALVES FOR PRODUCING EQUALISATION OF PRESSURE.

13. *Theory of Valves for Producing Equalisation of Pressure at the End of the Stroke.*—In fig. 12 is shown a form of valve for this purpose. The passages  $s, s$  in the cylinder, corresponding to steam passages, are for the admission and discharge of air from either side of the piston. The space  $a$  is that through which air is admitted, and the space above and around the valve is connected with the discharge pipe. A valve  $b$ , similar to the distribution valve of a Meyer expansion valve, has vertical passages at either end, which are closed at the top by a plate  $c$  held down by the pressure of the air above it, and by two spiral springs. There is also a passage which we shall call the equalisation passage, which connects the two passages  $s, s$ , and therefore both ends of the cylinder. The inside edges of this passage coincide with the inside edges of the passages  $s, s$ . By outside lap is meant the distance between the outside edge of a passage  $s$  and the inside edge of a vertical passage in  $b$ . The inside lap is the distance between the inside edge of a passage  $s$  and the corresponding inside edge of the valve. Fig. 13 shows the crank  $cs$  and the eccentric  $se$ , and the angle of advance is  $hs e$ , but the motion is in the opposite direction to that of a steam engine, as shown by the arrow. Fig. 14 is the valve diagram, which is similar to a steam-engine valve diagram. If  $cn$  and  $cr$  are the inside and outside laps, while  $cp$  and  $cq$  are the widths of the equilibrium passage, then when the valve is moving to the left, and is to the left of mid-stroke by the amount  $cn$ , the eccentric centre line, or briefly the eccentric, is at an angle  $qcd$  from the dead centre, and the passage is just about to open. As the valve moves further to the left the eccentric approaches

the dead centre, and when the valve has moved  $cd$  from mid-stroke the eccentric is on the dead centre. The valve now commences to move back, and the left-hand passage  $s$  is gradually closed. Inflow stops when the valve is a distance

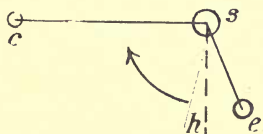

FIG. 13.

$cn$  to the left of mid-stroke and is moving to the right, and the eccentric is then at  $cb$ —*i.e.*, an angle  $bcd$  from the dead centre. As the eccentric rod is very long, the motion is practically harmonic, and  $gnb$  is perpendicular to  $ds$ . When the valve is a distance  $cp$  to the left of mid-stroke, and the right-hand end of the equalisation passage just about

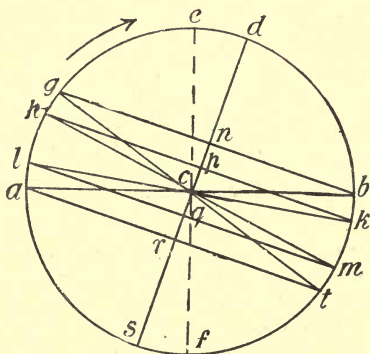

FIG. 14.

to open to the right-hand passage  $s$ , equalisation of pressure commences, the air flowing from the right to the left side of the piston, the eccentric being now  $kcd$  from the dead centre.

The valve passes over its middle position, that shown in fig. 12, and when it is a distance  $cq$  to the right of mid-stroke equilibrium ceases, and the air on the left of the piston is compressed by its motion to the left. When the valve is  $cr$  to the right of mid-stroke, the vertical passage in  $b$  on the left opens to the passage  $s$ , and air would be expelled were it not for the valve  $c$ , which does not rise until the pressure beneath becomes a trifle greater than that above. The valve moves to the end of its stroke to the right, and returns, closing the left passage  $s$ , so that discharge ceases; and we shall show that if  $cr = cn$ , this will be at the end of the stroke of the piston to the left. When the valve is  $cq$  from mid-stroke and moving to the left, the left-hand end of the equalisation passage is just about to open, and the right-hand end closes when the valve is  $cp$  to the left of mid-stroke. While, therefore, the eccentric moves through the angle  $lch$  equilibrium takes place. Admission on the left again takes place when the valve is  $cn$  to the left of mid-stroke. Thus  $ds$  may be looked on as the line of stroke of the valve  $gc, cb, ck$ , etc., as the positions of the eccentric relative to it when the valve is  $cn, cp$ , etc., from its mid-stroke, and  $ds$  may be called the valve line. The crank leads the eccentric by the angle  $cse$ , fig. 13; so that if a line  $acb$  be drawn making the angle  $acd$  equal to  $cse$ , fig. 13, then, if  $acg$  be the angle the crank makes with the line of stroke, and  $gnc$  is a right angle, then the valve is  $cn$  to the left of mid-stroke, and similarly for the other positions. So that  $cg$  is the position of the crank when admission commences and  $cb$  when it ceases;  $ck$  and  $cl$  are the positions when equalisation of pressure commences,  $cm$  and  $ch$  when it ceases;  $ct$  and  $ca$  when the left vertical passage in the valve is connected to and cut off from  $s$ . In the triangles  $arc, cnb$  the angles at  $c$  are equal, and those at  $n$  and  $r$  are right angles,  $ac$  being equal to  $cb$ . Therefore  $cr$  and  $cn$  are equal, and the outside lap of the valve is equal to the inside, and these and the angle of advance are evidently determined by  $cg$ ;  $cb$  must be on the stroke line, and  $cd$  must bisect the angle  $gcb$ . In fig. 15 the connection between the indicator diagram and  $cg$  is shown. Between  $b$  and  $k$ ,  $a$  and  $l$ , fig. 14, there will be a slight

compression of the air from the atmospheric line on the left and right of the piston respectively, but the portion of the stroke travelled is so small that these may be neglected.

In fig. 15, instead of  $fe$  being vertical and the commencement of the expansion curve  $ed$  being at  $e$ , there should at first be expansion, as shown dotted by  $fl$ , while the crank travels from  $a$  to  $l$ , fig. 14, then equalisation, causing the drop  $lm$  (supposed instantaneous); following this  $mh$ , a very

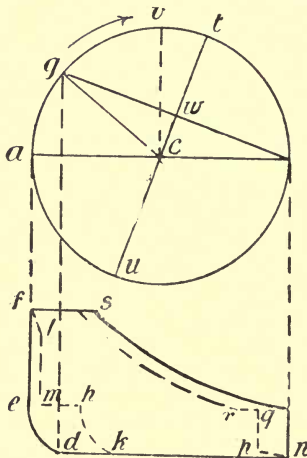

FIG. 15.

short horizontal line, exaggerated in fig. 15, while the crank travels from  $l$  to  $h$ , fig. 14; and finally expansion  $hk$ , while the crank moves from  $h$  to  $g$ . Similarly, there will be compression  $np$ , equalisation  $pg$ , a horizontal line  $qr$ , and compression  $rs$ , fig. 15, while the crank passes over  $b$ ,  $km$ , and part of the arc  $ta$ . The points  $r$  and  $h$  are, however, so very close to the ends of the indicator diagram that equalisation may be supposed to take place at the end of the stroke, and instantaneously, and  $d$  calculated on this assumption. This fixes  $g$ , which is directly above  $d$  if we neglect the effect due to the obliquity of the connecting rod,



and if  $gcb$  is bisected by  $uct$ , the angle of advance is  $vct$ . Joining  $bg$ , we have the mean inside lap  $cw$ , which also equals the mean outside lap. In order to find the actual values for both ends of the valve, allowing for the obliquity of the connecting rod, we must proceed as in fig. 16. Suppose the crank to the left of the figure; draw  $ab$ ,  $ut$  as in fig. 15, and mark off  $m$  and  $p$ , the points of admission, so that  $mb$  and  $ap$  are equal to  $dn$  in fig. 15. Draw  $mg$  and  $pg_2$  perpendiculars to  $ab$ . Then, as before,  $cn$  and  $cr$  give the laps, neglecting obliquity of the connecting rod; from

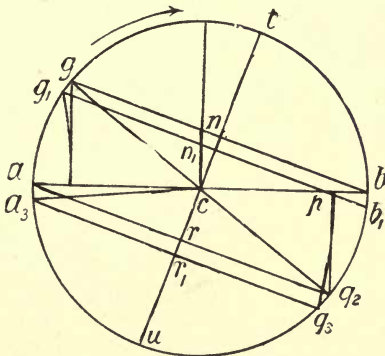

FIG. 16.

centres on  $ba$  produced draw two arc of circles  $mg_1$  and  $pg_2$ . Then at the commencement of admission the crank will be at  $cg_1$  and  $cg_3$ . Drop perpendiculars  $g_1n_1b_1$  and  $g_3r_1a_3$  upon  $ut$ ; then the inside lap on the left must be  $cn_1$  and that on the right  $cr_1$ , so that admission will cease at  $b_1$  and  $a_3$ , but as these points are so near the dead centre, this will be of no consequence. The outside laps should have the mean value  $cn$ , so that discharge will cease exactly at  $a$  and  $b$ . The position of the point  $d$ , fig. 15, depends, of course, upon the exponent chosen for the expansion curve;

$$n = 1.25$$

is a good value.

## CHAPTER IV.

## BLOWING ENGINES.

14. These are used for supplying air to blast furnaces and Bessemer converters. In the former pressures of half an atmosphere by gauge used to be customary, but now, following American practice, we find this is being increased to 20 lb. above the atmosphere. Bessemer blowing engines supply air at a pressure of  $1\frac{1}{2}$  to 2 atmospheres by gauge, or  $22\frac{1}{2}$  lb. to 30 lb.

Blowing engines are of very large size and power in consequence of the large amounts of air required. Many beam engines are still in use, but modern practice prefers the horizontal or vertical direct-acting type, in which each of two steam pistons drives an air piston by means of its tail rod. The steam cylinders are therefore in the middle of the engine, and on the other side of them from that on which are the blowing cylinders is the crank shaft, which usually has two overhung cranks, generally set at right angles, with a flywheel between them. In vertical engines the blowing cylinders are at the top. The air valves are self-acting or mechanically controlled, and the steam valves are of many different types, slide, Corliss, and conical valves being used. In old-fashioned blowing engines we find low piston speeds, such as 240 ft. per minute, with 8 ft. stroke, and therefore 15 revolutions; but improvements, especially in the air valves, have made speeds of 450 ft. per minute possible, even with self-acting valves. We shall first describe a number of blast-furnace blowing engines, and afterwards deal with the Bessemer type.

15. *Blast-furnace Blowing Engine, constructed by L. Lang, Budapest, for the Königlich ungarischen Eisen und Stahlwerks, Vajdahungad.*\*—Figs. 17 and 18 show the general arrangement in plan and elevation. There are two blowing cylinders of 2,070 mm. (81.6 in.) diameter, whose pistons are driven direct from those of the two steam

---

\* Stahl und Eisen, 1897, No. 22.

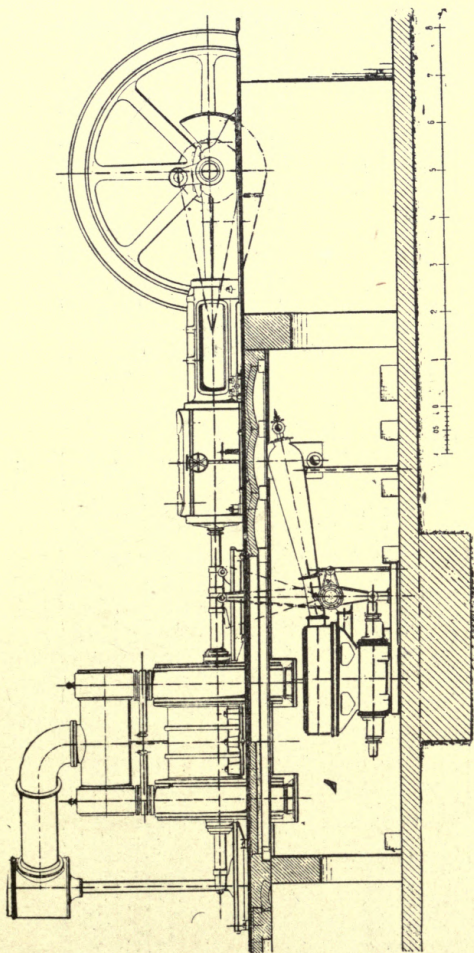

FIG. 17.

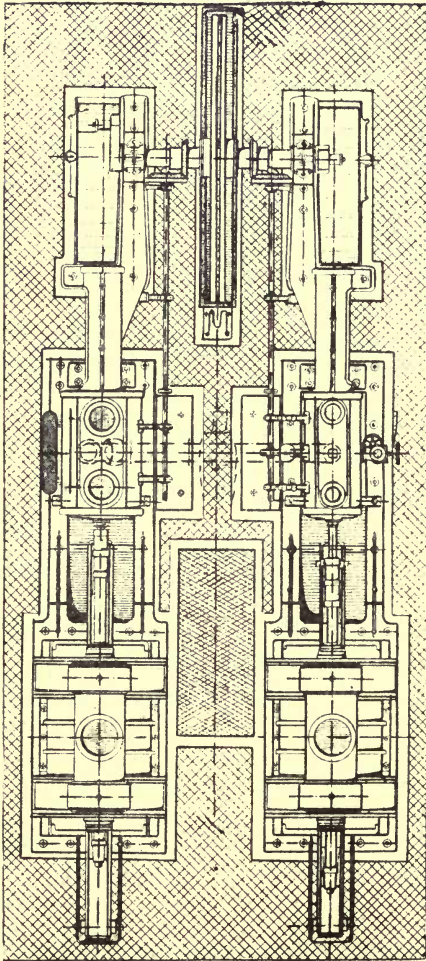

FIG. 18.

cylinders, whose diameters are 725 and 1,150 mm. (28·5 and 45·2 in.), the stroke being 1,350 mm. (53·1 in.); the number of revolutions per minute is 40 to 50, and the steam pressure

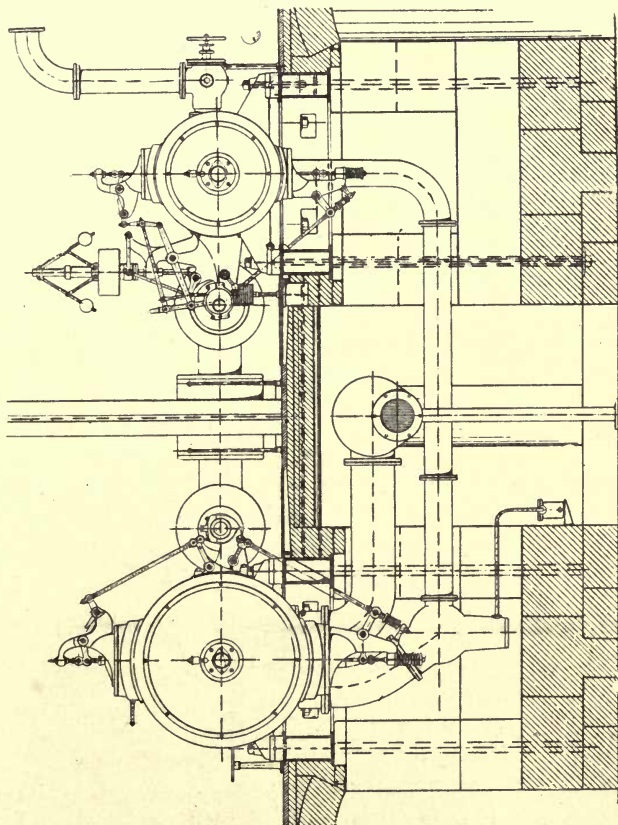
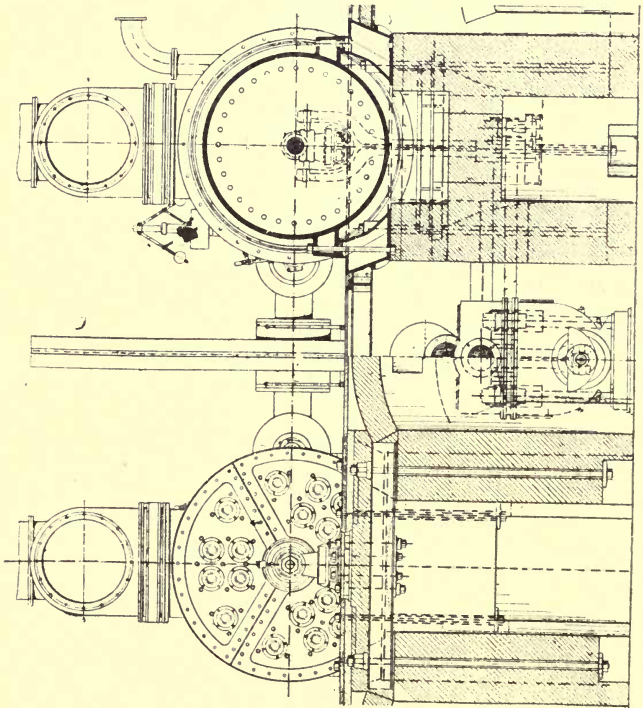

FIG. 19.

120 lb. The air is discharged at a pressure of 18 to 25 cms. of mercury, or 7·1 to 9·85 lb. per square inch, and the volume discharged lies between 700 and 900 cubic metres,

or 24,600 to 31,700 cubic feet per minute. The air pump is horizontal and double acting, lies beneath the floor, and is driven by a lever whose upper end is attached to the guide block of the blowing cylinder piston rod on the high-pressure engine side. The air is drawn in through two



passages in the foundation which are connected with a chimney. The discharge pipe is seen in fig. 17. The valves are double beat, and are driven by Collmann's valve gear, fig. 19. The high-pressure cut-off is varied by the governor, and the low-pressure by hand.

Fig. 20 shows a transverse section and end view of the blowing cylinders, while figs. 21 and 22 show the valve chest, and figs. 23 and 24 the valve construction, which is the most interesting part of this engine. Fig. 23, on the left, shows to a reduced scale views of the suction and discharge valves, and on the right two half sections, the upper one that of the suction valve, and the lower that of the discharge valve. Fig. 24 contains a view perpendicular to the axis of the valve, while above and below are sections of the valve guards or stops. In fig. 23 will be seen the thin plate of steel which forms the suction valve. It is 0.8 mm. (.0315 in.) thick, and has an external diameter of 244 mm. (9.6 in.), and an internal diameter of 120 mm. (4.72 in.). On its left is the valve-seat casting of steel, having two concentric rings of V section forming valve seats, The sectioning and vertical line to the right of the figure represents the piston at the end of its stroke, and gives some idea of the clearance space. To the left of this is the valve guard of cast steel, held to the valve seat by the central bolt; and finally, there are three strips of steel plate F K, fig. 24, which are riveted at their ends F to the valve guard, and at K to the valve, so that it moves to and fro without friction, and, as the moving mass is very small, without shock, nor can it get jammed in any way. When fully open the valve ring rests upon two narrow concentric broken rings on the guard, which are shown shaded in the central drawing of fig. 24, and which are not continuous, in order to leave space for the end of the plate springs F K. The upper half of this drawing shows the suction valve guard, as seen from the left, with the three springs, the valve being supposed removed, its position indicated by the two dotted circles. The lower half of this figure shows the delivery valve guard, the springs being shown dotted and the valve sectioned. The valve guards are shown in section in the upper and lower views, the former having valve and springs in place.

The discharge valve differs from the suction only in being formed of two plates, the outer one 0.4 mm. thick (.015 in.), a space of half a millimetre being left between the two. The suction valve has to open when the crank is near the dead

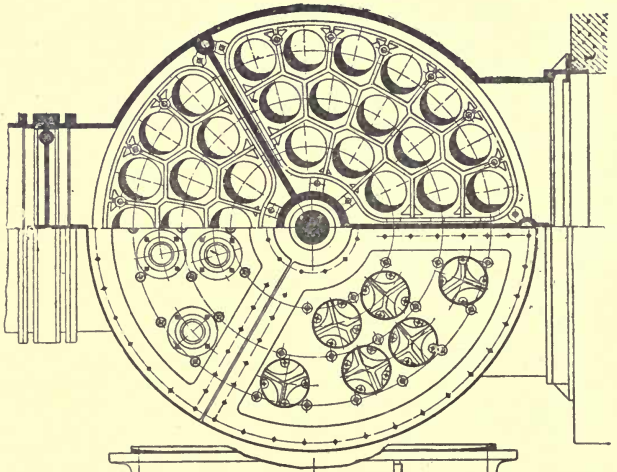

FIG. 22.

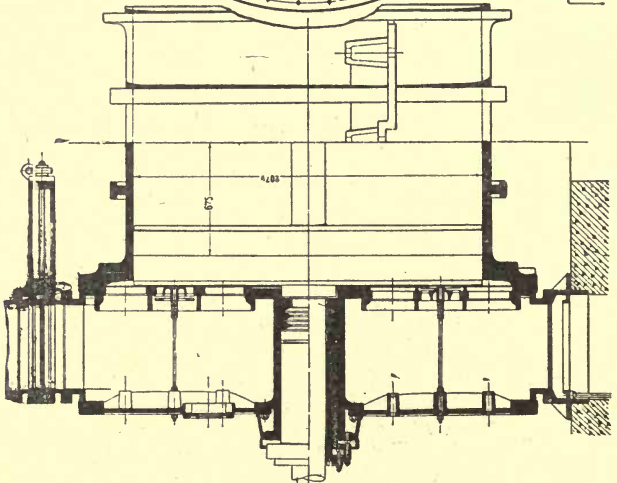

FIG. 21.



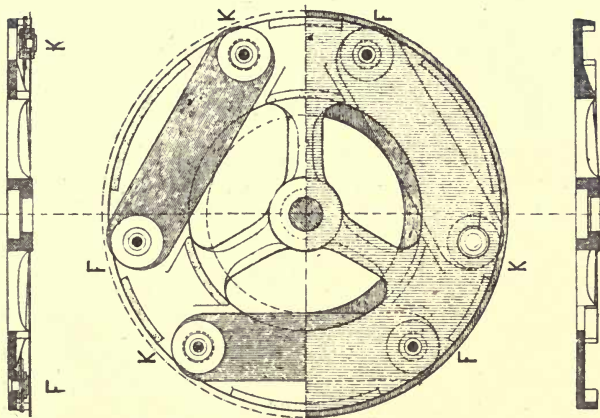

FIG. 24.

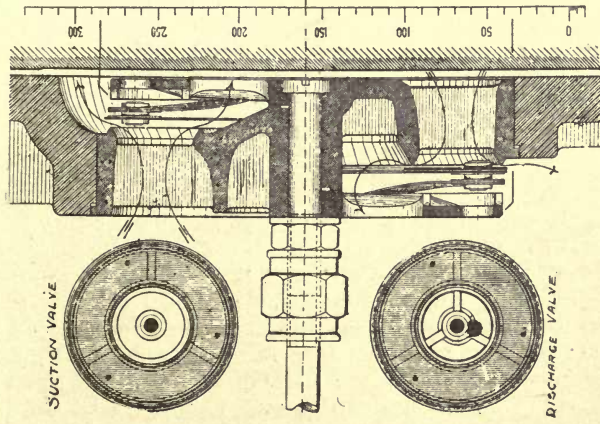

FIG 23.

centre, but the delivery valves, when it is in rapid motion; so that an oil or air cushion is provided by the space between the plates to lessen the shock. The arrows in fig. 23 show the direction in which the air flows through the valve. Fig. 22, on the extreme right, shows a front elevation of the valve seat cover, which, according to the custom adopted for leather clack valves, is divided into two unequal parts, one third of the area—the upper part—being for the delivery valves, and the remainder for the suction. When the engine was constructed these valves were a novelty, and the purchaser required that the valve seat cover should be so constructed that in the event of the valves working unsatisfactorily they might be replaced by ordinary leather clack valves. In order to provide for this the cover had to be made in the complicated grating form shown in the figure, and a false cylinder flange had to be bolted to the cylinder flange, as the valve seat cover took up more room than it would have done had provision only to be made for the new valves. In later designs fewer and larger valves are fitted, the number of the suction being equal to that of the delivery valves, the former having a greater stroke. The best number is nine of each, having a diameter one-sixth that of the cylinder, and the whole of the valve can be cast in one piece, as in the Bessemer blowing engine for the Reschitza Ironworks, in South Hungary, and the blast-furnace blowing engine for the Aplerbecker works. For long-stroke engines with high piston speed, and for vertical engines, the valves can be placed in a ring at the cylinder end, although this slightly increases the clearance, which still, however, remains much below that usually found with self-acting or mechanically-controlled valves.

It will be noticed that in fig. 21 the valve seat is pressed into the inner cover by means of the central bolt. The valve is packed by means of three or four turns of cord soaked in boiled varnish. Each hand-hole cover has a glass window through which the working of the valves can be observed. At the top of the same figure will be seen a valve which can be closed when a discharge valve has to be withdrawn. To do this it is first necessary to withdraw three or four suction valves from the same end of the

cylinder, so that the air drawn in at each stroke can be again discharged through them. The valve above mentioned may then be closed, and one of the hand holes in the upper

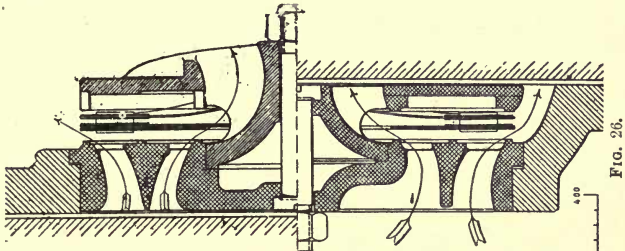

FIG. 26.

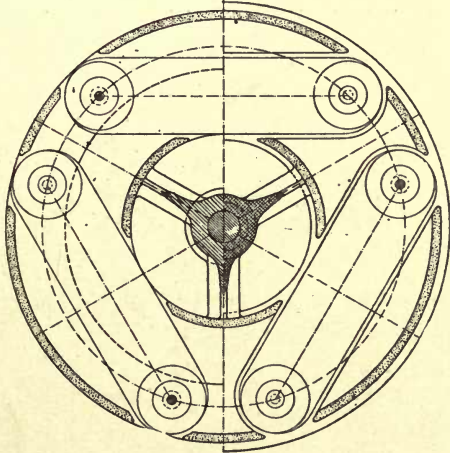

FIG. 25.

part of the cover opened, the valve withdrawn, and a new one put in its place. The valve chest need only be removed when the piston requires repair. As a matter of fact, during the first two and a half years, during which the engine was

continually at work, no repairs were required. The actual sizes of valves constructed are 260, 280, 300, 320, and 340 mm. diameter (10·25, 11·8, 12·6, and 13·4 in.), with strokes of 15 to 30 mm. (.59 to 1·18 in.). It is only where the pressure is low that a V section can be given to the valve seat, and for compressors the form shown in fig. 25 is used. In order to avoid the necessity of using a thicker plate for the valve there is a third intermediate seat. Fig. 26 is a plan. The upper half of each figure shows the delivery valve, and the lower the suction valve, in each case with the guard removed.

15. *Blast-furnace Blowing Engine, constructed by Breitfeld, Danek, and Co., of Prag-Karolinenthal.*—The leading dimensions of this engine are :—

Diameter of high-pressure cylinder.....	900 mm. (35·4 in.)
Diameter of low-pressure cylinder .....	1,380 mm. (54·4 in.)
Diameter of both blowing cylinders.....	1,950 mm. (76·8 in.)
Stroke .....	1,400 mm. (55·1 in.)

The steam cylinders have Corliss valves, the high-pressure under the control of the governor, the low-pressure cut-off being adjustable by hand. As the speed can be varied between 33 and 53 revolutions per minute, the Pröell governor has its lever fitted with two weights, the adjustment of which modifies the speed. The engine is jet-condensing, a double-acting horizontal air pump being placed beneath the floor and driven by means of a coupling rod and bell crank from the low-pressure crank pin. Its diameter is 640 mm. (25·2 in.), and its stroke about 546 mm. (21·5 in.). The discharge is 650 cubic metres (22,850 cubic feet), at 43 revolutions per minute; 760 cubic metres (26,700 cubic feet), at 50 revolutions; and 800 cubic metres (28,100 cubic feet), at 52½ revolutions. The highest air pressure is 0·7 kg. per square centimetre (nearly 10 lb. per square inch), and the pressure of the steam at the engine 110 lb. per square inch, and about 18 expansions.

Fig. 27 shows a side elevation and fig. 28 a plan of the blowing cylinders; the left-hand half of the former is an outside elevation. The valve gear, being on the further side of the cylinder, is shown dotted. It consists of a wrist plate

having three arms, the middle one being driven by an eccentric, and each of the other two driving a discharge and suction valve. The gear is so arranged that the valves open rapidly, but their motion while they are closed is extremely small, thus reducing wear and work wasted in friction; the valves, of course, are of the Corliss type. The lower valves control the admission of the air, but as the moment of

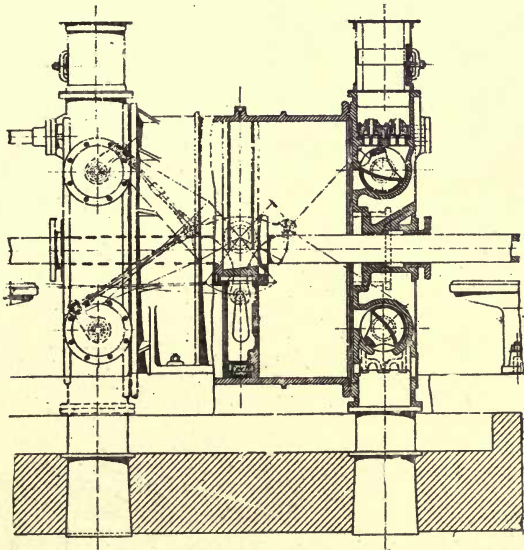

FIG. 27.

discharge depends on the pressure in the discharge pipes, self-acting valves are fitted above the Corliss discharge valves, there being 20 at each end of the cylinder. The cylinder ends and covers are shown in figs. 29, 30, and 31, and a larger view of one of the self-acting valves in fig. 32. The Corliss discharge valves close just at the end of the stroke, so that the space above them is filled with air at discharge pressure. The self-acting valves consequently return to their seats quietly, and this all the more so

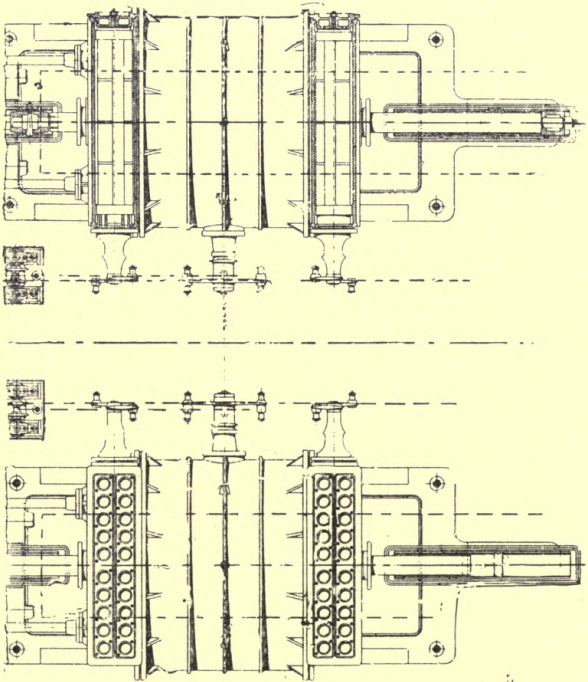

FIG. 28.

because, their guides being screwed spirally, their descent is somewhat checked. Owing to the fact that the Corliss

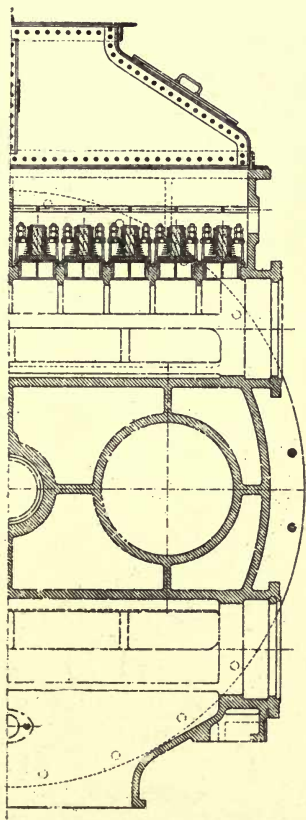

FIG. 29.

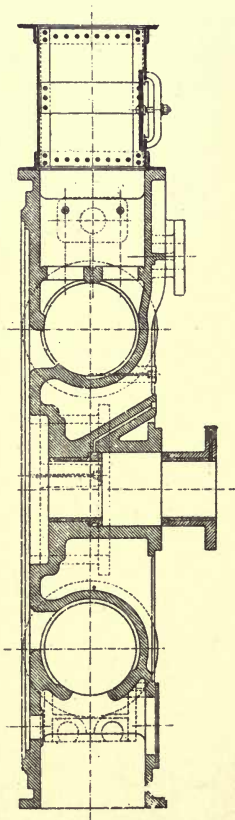

FIG. 30.

valves cut off the cylinder from the pressure pipes, the self-acting valves need not close rapidly, and have the time of a little more than one stroke to do so.

The Corliss valves are shown in plan in fig. 28. The section of the suction Corliss valve opening is 2,100 sq. cms. (326 sq. in.), that of the discharge valve is 1,800 sq. cms. (279 sq. in.), that of 20 self-acting valves 2,450 sq. cms.

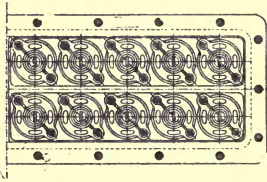

FIG. 31.

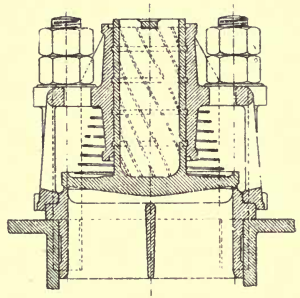

FIG. 32.

(380 sq. in.), and that of the blowing cylinder 29,515 sq. cms. (4,570 sq. in.). The corresponding ratios are—1 : 14. 1 : 16.4, and 1 : 12. The corresponding velocities at 33 revolutions are 21.6 m. per second (70.75 ft. per second),

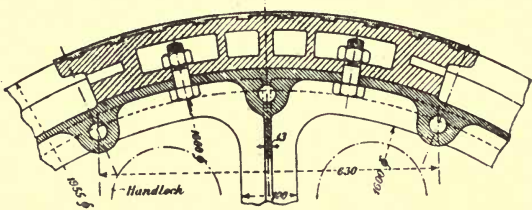

FIG. 33.

25.3 m. per second (83 ft. per second), and 18.5 m. per second (60.6 ft. per second); at 53 revolutions, the highest speed, these become 34.6, 40.5, and 29.6 m. per second (113, 132.5, and 97 ft. per second). The corresponding piston speeds are 303 ft. and 486 ft. per minute. The air is drawn into the cylinders from a passage beneath. The



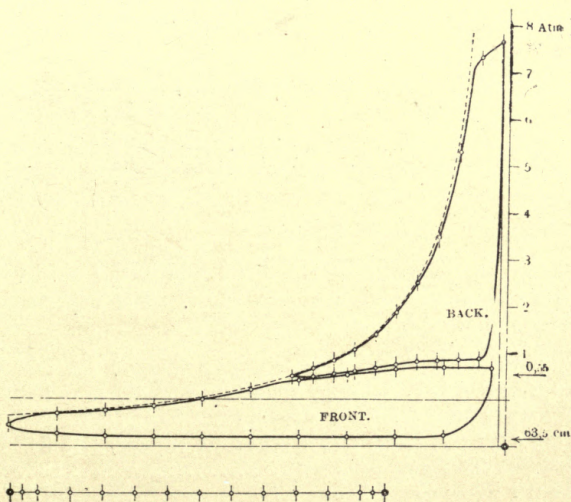
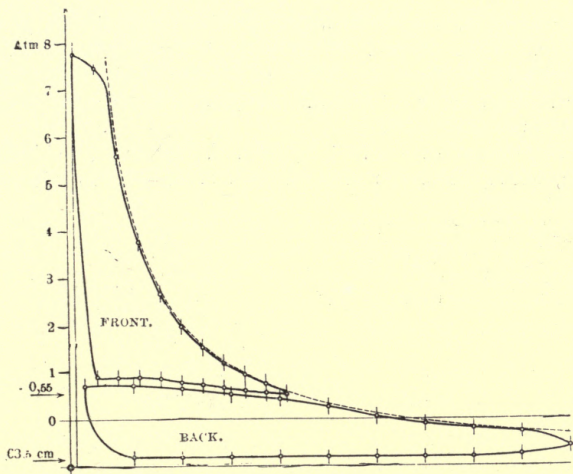

FIG. 34.

connections with the discharge pipe are not shown in the figures. Figs. 29 and 30 show that the discharge valves are easily accessible through a number of hand holes above them. Fig. 33 is a section through the blowing piston, which is of cast steel.

The engines were tested by Prof. E. Hermann, on August 20th, 1897, before the engines were connected to the blast

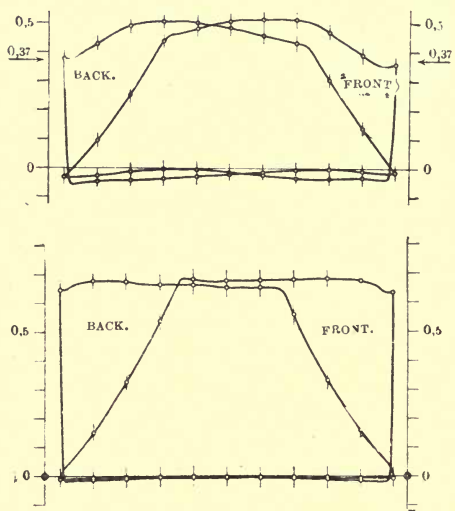

FIG. 35.

furnaces, the pressure of the discharge being raised by throttle valves in the discharge passages. The experiments gave the following results :—

Horse power of H.P. cylinder (chevaux vapeur) ....	304·91.
Horse power of L.P. cylinder (chevaux vapeur).....	333·01.
Total horse power (chevaux vapeur) .....	637·92.
Blowing cylinder, horse power (chevaux vapeur) ...	547·08.
Mechanical efficiency, per cent.....	85·75.
Steam per horse power hour .....	15·2 lb.

Fig. 34 shows the combined diagrams of the steam cylinders, and fig. 35 the blowing diagrams. Of these latter the upper were taken during the experiments, and the lower when the engines were at work. The irregularity of the suction lines is due to the closing during the experiments of one of the suction passages, and the rise of the discharge pressure at the middle of the stroke to the throttle valves. The manometer showed 0·37 of an atmosphere during the experiments, but with such peculiar diagrams it would evidently be unfair to calculate from them the efficiency of compression or the total efficiency of the engines. The lower diagrams have a mean effective pressure of 8·05 lb. per square inch, so that the efficiency of compression

$$\eta_2 = \frac{\cdot976 \times 14\cdot7 \text{ hyp. log } 1\cdot64}{8\cdot05} = 88 \text{ per cent,}$$

the volumetric efficiency being 97·6 per cent, and the discharge pressure 1·64 atmosphere absolute. This, with the mechanical efficiency obtained during the experiment, would give a total efficiency

$$\eta_1 = 88 \times \cdot8575 = 75\cdot6 \text{ per cent.}$$

15a. *Blast Furnace Blowing Engine constructed by the Sächsischen Maschinenfabrik, Chemnitz.*—The leading dimensions of this engine are:—

Diameter of each steam cylinder...	1,100 mm. (43·4 in.)
Diameter of each blowing cylinder	2,350 mm. (92·6 in.)
Stroke .....	1,800 mm. (71·9 in.)

The independent condensing engine, placed beneath the floor, has the following leading dimensions:—

Diameter of steam cylinder.....	450 mm. (17·75 in.)
Air pump cylinder diameter .....	550 mm. (21·65 in.)
Stroke .....	680 mm. (26·8 in.)

The boiler pressure is 60 lb., with a cut-off at 12 per cent of the stroke; the discharge, at 30 revolutions per minute, is 900 cubic metres or 31,700 cubic feet of air per minute of free air, which is delivered at a pressure of  $\frac{4}{10}$ ths of an atmosphere, or 5·88 lb. per square inch. The speed can be

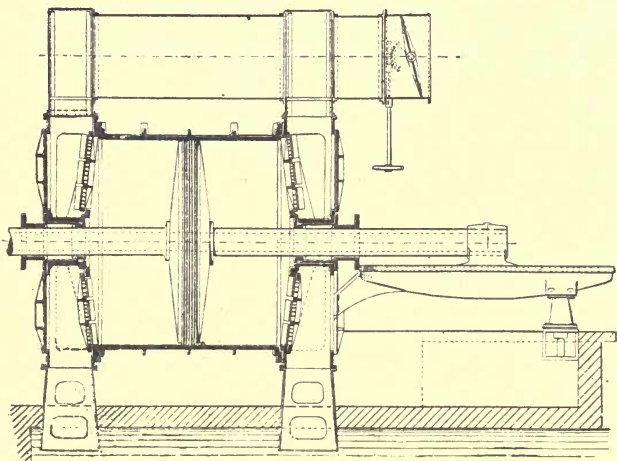

FIG. 36.

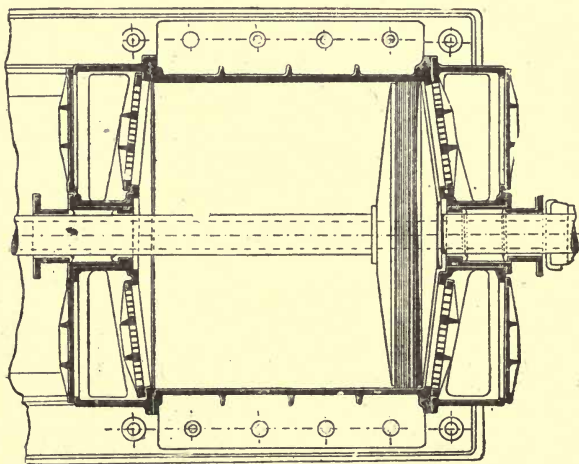

FIG. 37.

varied between 16 and 38 revolutions per minute by a change in the load of the governor. The mechanical efficiency was found to be 86 per cent, and the pressure 0·46 of an atmosphere at 35 revolutions per minute, at which speed the engine ran very quietly.

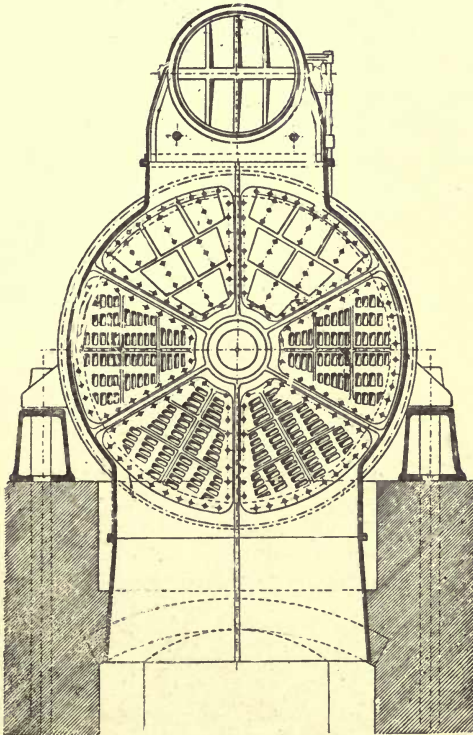

FIG. 38.

Figs. 36, 37, 38, 39, and 40, for which we are indebted to the makers, are a sectional elevation of the blowing cylinder; a sectional plan of the same; a transverse section through the valve chest, showing the delivery valves, the suction

passages, and the throttle valve, by means of which the cylinder may be cut off from the pressure pipes; an end view, looking from the steam cylinders; and an elevation, partly in section, of the whole engine.

As shown in fig. 38, one-third of the area of the cylinder end contains the delivery valves, and two-thirds the suction. They are all of leather, each is fastened in the middle by three screws, and each covers 6 or 10 passages; there are 24 suction valves at each end and 12 delivery. The two upper

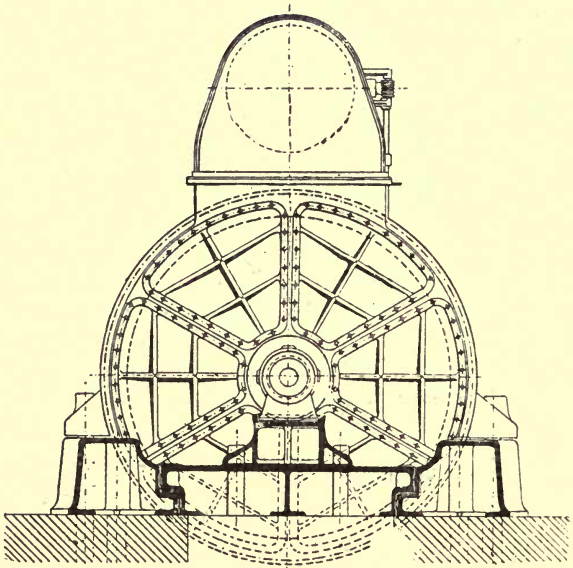

FIG. 39.

sections are, of course, separated by ribs from the four lower, and the area of the discharge valves is one-eighth that of the cylinder, while that of the suction is one-fifth.

Fig. 36 shows that the engine is supported by two funnel-shaped castings, through which the air flows from a passage in the foundation, so that the air may reach the engine as

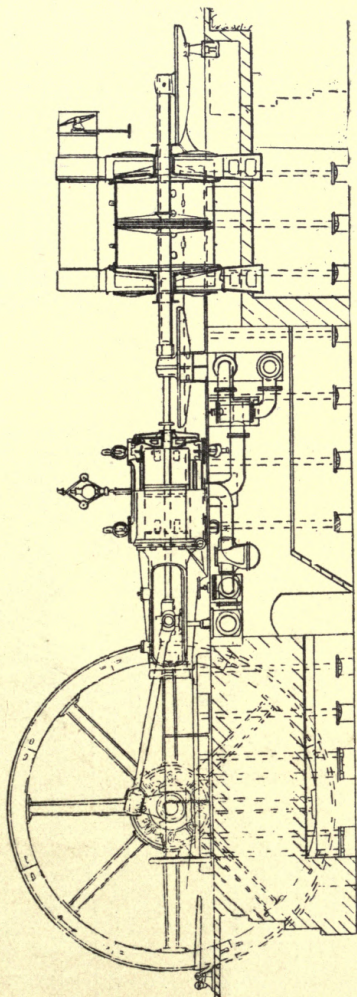
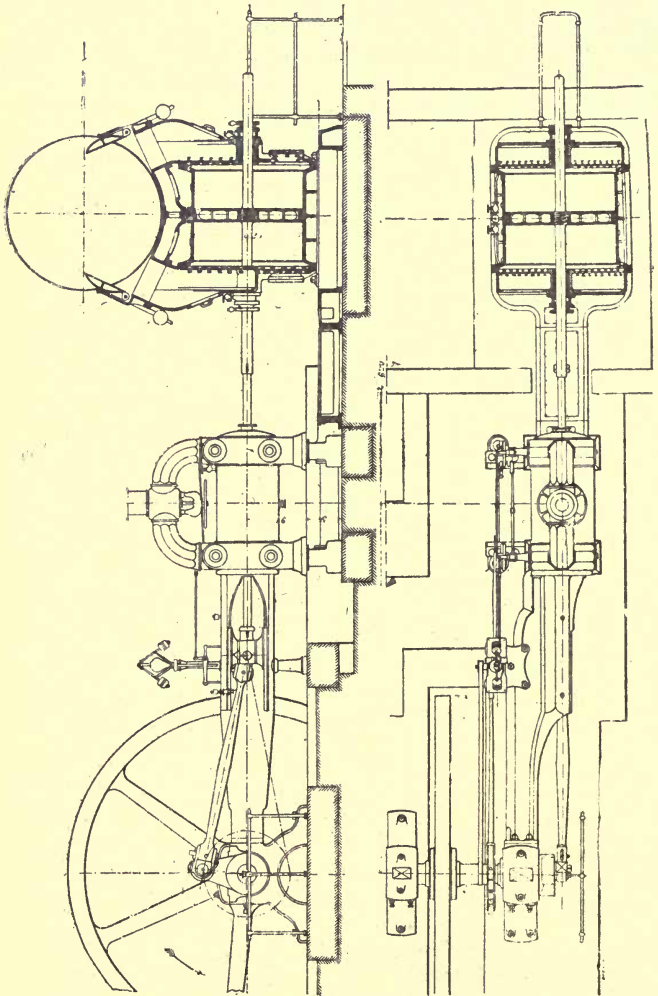

FIG. 40



Figs. 41 and 42.



cool as possible. We may note here that this does not influence the work per stroke, which depends on the volume of air drawn in, but it directly affects the weight of air delivered, which is, of course, of importance in a blowing engine. The speed of the engine is controlled by varying the expansion, the valves, of which there are four, being driven by eccentrics on a pair of side shafts.

16. *Blast-furnace Blowing Engine by Messrs. Schneider and Company, Creusôt.\**—Figs. 41 and 42 show a horizontal

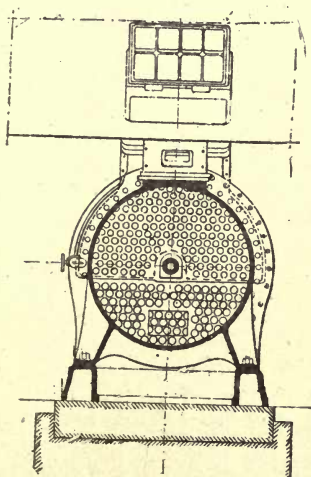

FIG. 43.

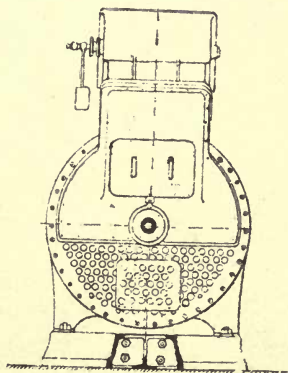

FIG. 44.

blowing engine with one steam cylinder 750 mm. (29·53 in.) diameter, and one blowing cylinder 1,770 mm. (69·69 in.) diameter, with a stroke of 1,400 mm. (55·12 in.). The steam cylinder has Corliss valves, and the blowing cylinder small metal valves, the discs of which are fitted with light closing springs. These discs are of special steel made at Creusôt, have considerable durability, and can be easily replaced. The inlet valves are arranged on the lower half

\* From *Engineering*, February 4th, 1898.

of the air cylinder, and the outlet on the upper half, figs. 43 and 44. The former figure shows a section, and the latter an end view of the cylinder. There are 150 inlet valves at each end, giving an area of 2.969 square feet, and 180 outlet valves, whose area is 3.56 square feet. As the effective section of the cylinder is 26.39 square feet, these are 0.1125 and 0.135 of the cylinder area. The weight of the flywheel is 11 tons, the indicated horse power 378, and that of the air cylinders 288, giving a mechanical efficiency of

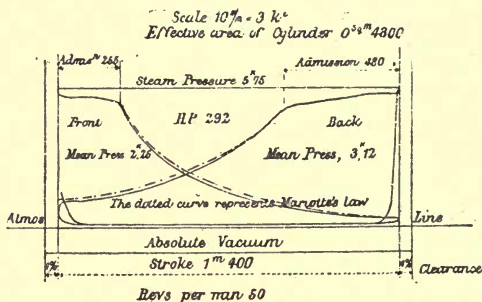

FIG. 45.—Diagrams from Steam Cylinders.

76.25 per cent. The blowing cylinder is connected to a reservoir, common to six machines, from which the service mains are taken that distribute the cold air to Cowper heating stoves. Each engine can be isolated from the reservoirs by means of valves placed upon the upper side of the pressure chamber. Indicator diagrams are given in figs. 45 and 46. The ratio of the mean atmospheric pressure and the absolute pressure to which the air is compressed is

$$r = \frac{29.92 + 11.81}{29.92} = \frac{41.73}{29.92} = 1.4 \text{ nearly.}$$

The volumetric efficiency is 98 per cent, disregarding the fact that the suction pressure is less than that of the atmosphere. The ideal horse power with 50 revolutions per minute is

$$\frac{14.7 \times 144 \times 26.39 \times 55.12 \times 100 \times 2.3 \times .146}{12 \times 33000} = 261.$$

The air efficiency is therefore

$$\eta_2 = \frac{261}{288} = 90.6 \text{ per cent,}$$

but the total efficiency is

$$\eta_1 = \frac{261}{378} = 69 \text{ per cent.}$$

Fig. 47 shows the governor,\* which controls both speed and pressure. A is the speed governor, which acts on a sleeve in the usual way, and lowers or raises the lever

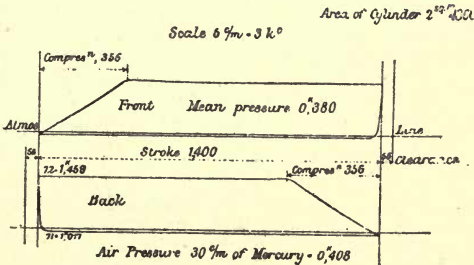

FIG. 46.—Diagrams from Air Cylinder.

beneath it, whose fulcrum is slightly to the left of its axis. A vertical arm, which has attached to its upper end a connecting link, acts by means of this upon the trip cam of the Corliss valve motion. But the horizontal lever is also acted on by the air piston B, the weight E, and the adjustment spring F. Air pressure acts on the under side of B, so that when the pressure is in excess of a certain desired quantity the lever is raised, and the cut-off in the steam cylinder takes place sooner. C is an oil brake to destroy oscillations, and D is the governor weight. The maximum engine speed is 54 revolutions, and the variation of pressure does not amount to .39 in. of mercury above or below the normal.

\* Appareils de Compression d'Air, from the Bulletin de la Société de l'Industrie Minérale, Tome VII.

17. *Delivery Valves constructed by the Gutehoffnungshütte, Oberhausen a. d. Ruhr.*—Fig. 48 is one of the delivery

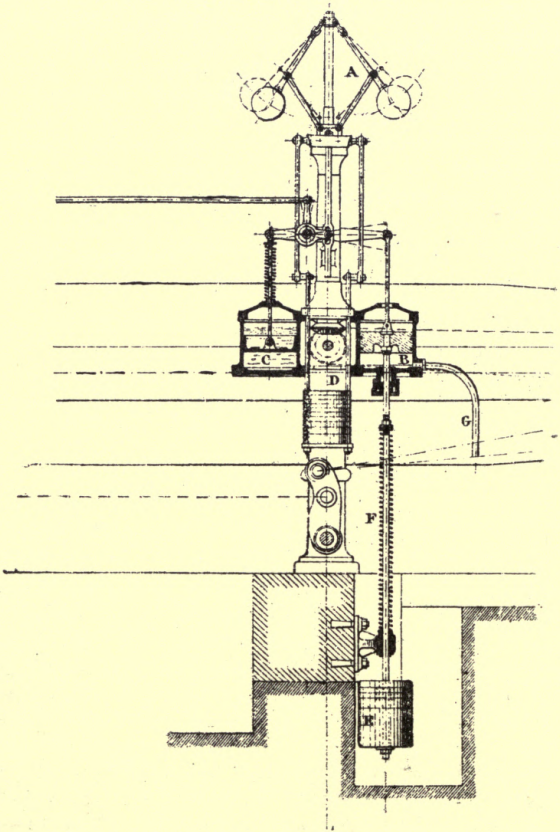

FIG. 47.

valves for a 500 horse power blast-furnace blowing engine. A portion of the piston is shown at the end of the stroke, and the valve is closed. An indiarubber cushion, fixed to

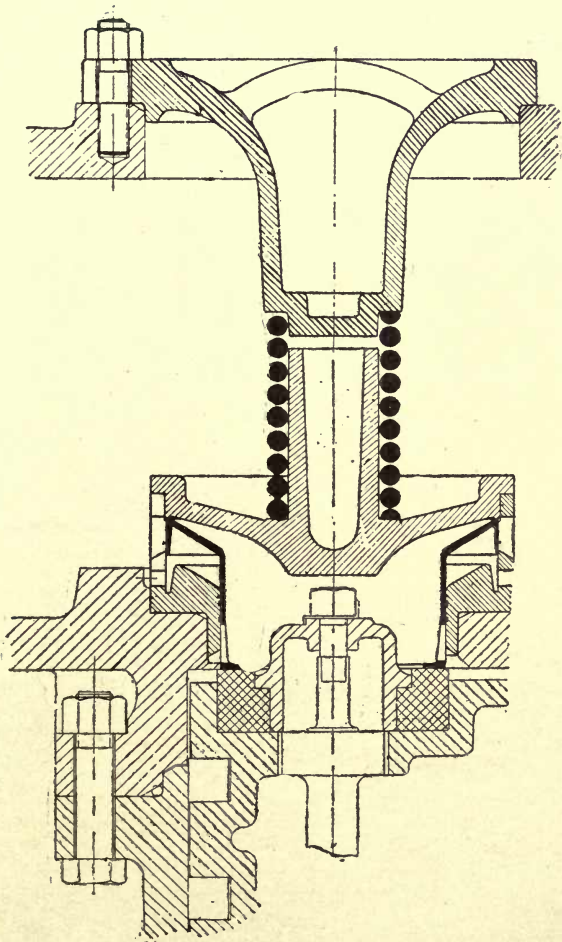

FIG. 45.

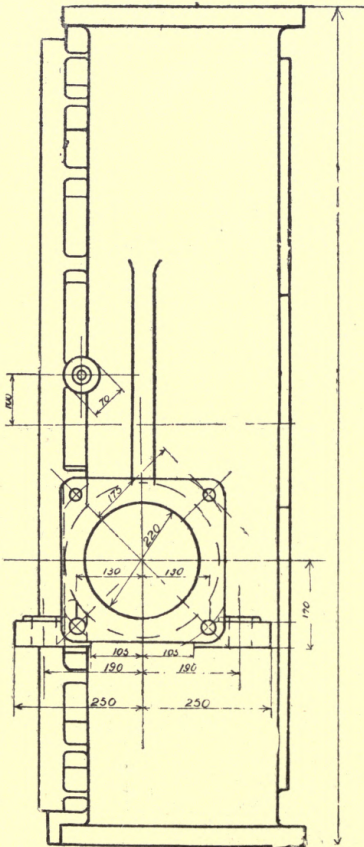

FIG. 49

the piston, is pressing the valve against the valve-box cover, which is held down by a spiral spring, and the valve itself is closing the delivery passages by its larger piston, whose diameter is 265 mm., or 10.45 in. When the piston returns the valve remains in the position shown, because the pressure on the inside is less than that on the outside, which comes on the under side of the piston through the small holes in the valve box. When, however, the piston returns

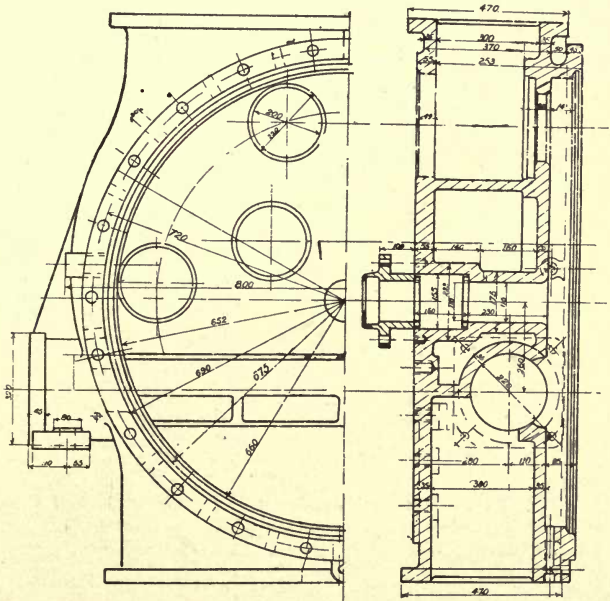

FIG. 50.

and the pressure again rises, the difference of the pressures on the inside and outside of the valve acting on the ring area, whose outer diameter is 265 mm., and inner 180, or 7.1 in., forces it open again until it is closed by the piston at the end of the stroke. The stroke of this valve is 26 mm., or 1.02 in. Bessemer blowing engines are fitted with similar valves.

18. *Blast-furnace Blowing Engine Cylinder, constructed by the Gutehoffnungshütte.*—Figs. 49, 50, and 51 show the cover of a blowing cylinder, whose diameter is 1,300 mm.

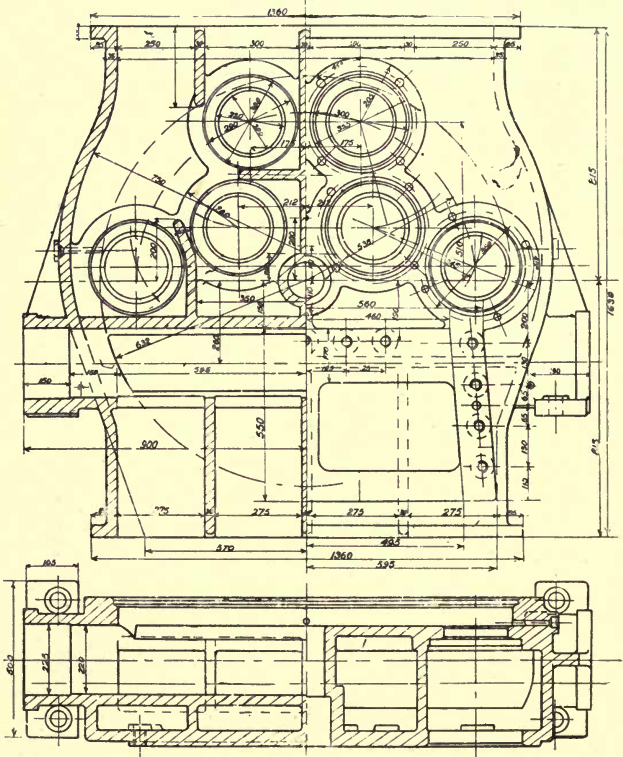

FIG. 51.

(51.2 in.), and stroke 750 mm. (29.5 in.) Fig. 49 is a side elevation, fig. 50 an end elevation looking from the inside, and on the right a sectional elevation through the axis, but



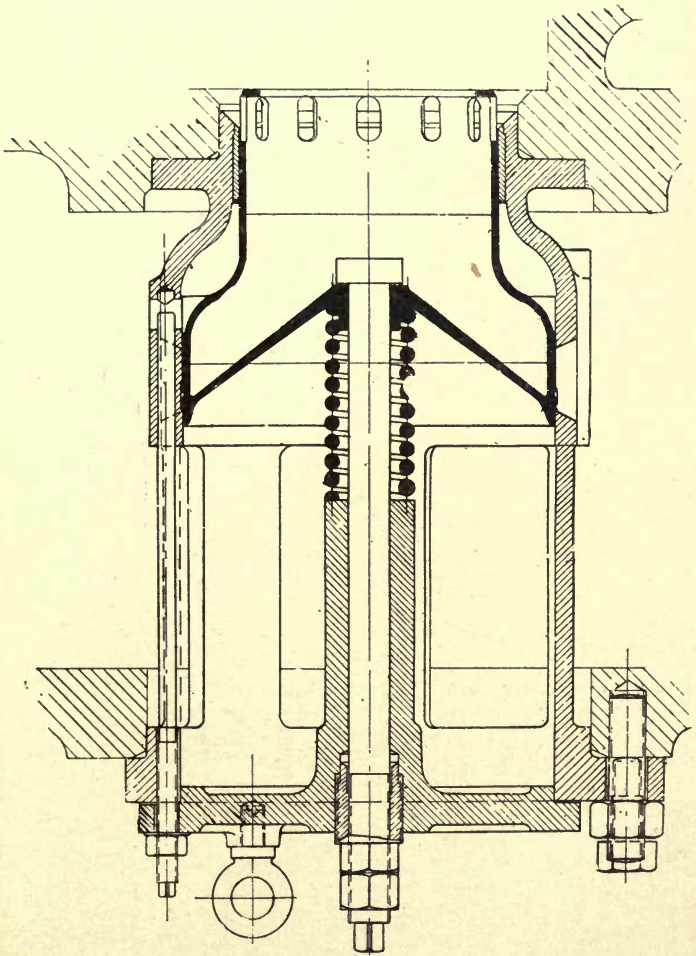

FIG. 52.

passing through the centre of one of the upper valve seats. Fig. 51, on the left-hand side of the upper view, is a sectional elevation by a plane perpendicular to the axis of the cylinder and passing through the axis of the Corliss suction-valve chest. The right half of the upper view is an outside eleva-

FIG. 53.

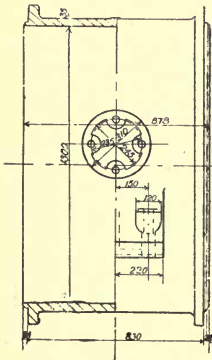

FIG. 54.

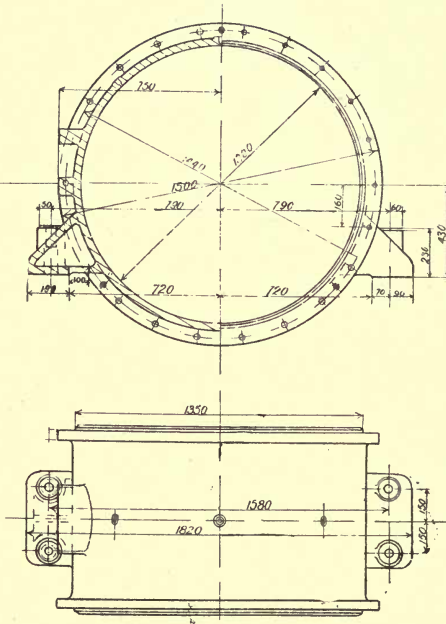

FIG. 55.

tion; the left half of the lower view is a sectional plan through the axis of the suction-valve chest, and the right half is taken through the centre of the lowest discharge valve. The other cover differs in nothing of importance from this.

A discharge valve is shown in fig. 52, and has a diameter of 160 mm. (6.3 in.). The action of this valve is the same

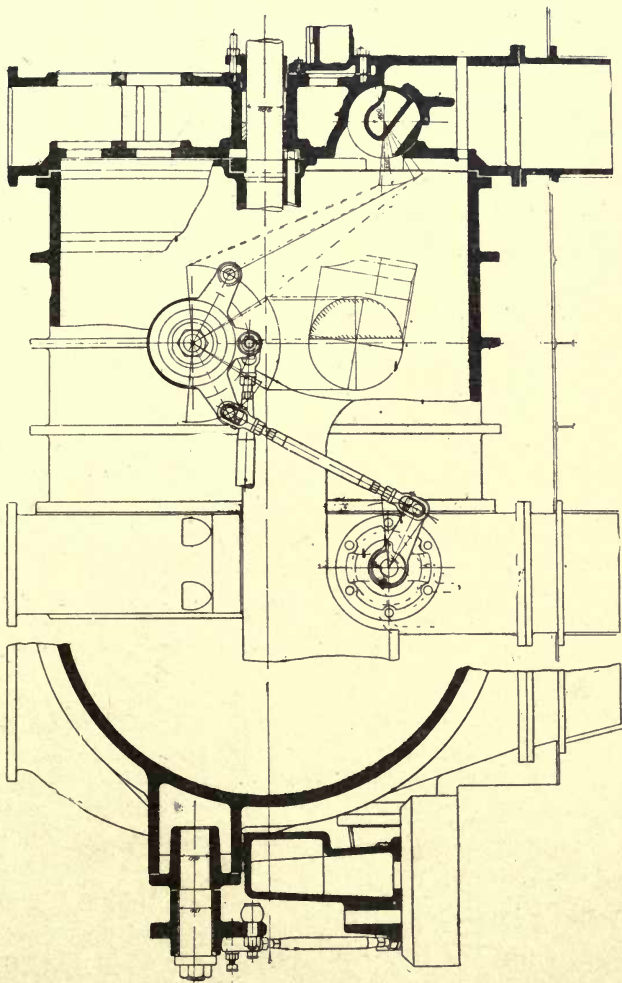

FIG. 57.

FIG. 56.

as that shown in fig. 48, the piston closing it at the end of the stroke. The general thickness of the cover is 35 mm. (1.38 in.), of the top and bottom flanges 40 mm. (1.58 in.), and of the flange connecting it to the cylinder 45 mm. (1.77 in.), while that of the end is 55 mm. (2.17 in.). Figs. 53, 54, and 55 show the cylinder, whose thickness is 35 mm., and that of the flange 45 mm. The facing for the wrist-plate bracket is shown in fig. 53.

19. *Blast Furnace Blowing Engine constructed by the Friedrich-Wilhelms Hütte, of Mühlheim a.d. Ruhr.*—Fig. 56 shows a transverse section through part of the cylinder of a large blowing engine, and fig. 57 a front elevation, partly in section. The diameter is 2,200 mm. (86.6 in.) and the stroke 59.1 in. The admission valves are of the Corliss type, which are oscillated by means of levers, connecting links, and a wrist plate driven by an eccentric, which is set 100 deg. behind the crank. The diameter of the valve is 400 mm. (15 $\frac{3}{4}$  in.), and it is double ported, with an overlap of about 1 $\frac{1}{2}$  mm. (.06 in.). The lever that actuates the valve is 350 mm., and it is set at about 63 deg. to the vertical when the wrist plate is in its middle position. The valve oscillates through an angle of 40 $\frac{1}{2}$  deg., but of this only 8 deg. are traversed while the valve is closed and there is any pressure upon it. At admission the angular velocity of the valve is seven-tenths of that of the wrist plate. The length of the connecting link can be adjusted. The valve diagram is shown below the wrist plate, the shaded part referring to the period during which the valve is open. The diameter of this circle that represents the piston stroke is inclined at 10 deg. to the vertical, and projected from this on the right is the indicator diagram. It will be seen that the admission commences shortly after the commencement of the stroke, when expansion from the clearance has ended, and the passage is again closed very soon after the end of the stroke. The compression is to seven-tenths of an atmosphere. The wrist plate oscillates through an angle of 65 deg., the arms that drive the connecting links being 420 mm. (16 $\frac{1}{2}$  in.), and that actuated by the eccentric rod 300 mm. (11.8 in.), the throw of the eccentric—*i.e.*, its eccentricity—being 160 mm. (6.3 in.). The discharge valves

are located in the upper half of the cylinder end ; they are not shown in place in figs. 56 and 57.

Fig. 58 is a sectional elevation through a valve, and fig. 59 another transverse to the axis, the right half showing the cover, the left a section through the discharge ports in the seat. The valve is of steel, its smaller diameter being 166 mm. (6.54 in.), and its larger 245 mm. (9.65 in.). It is

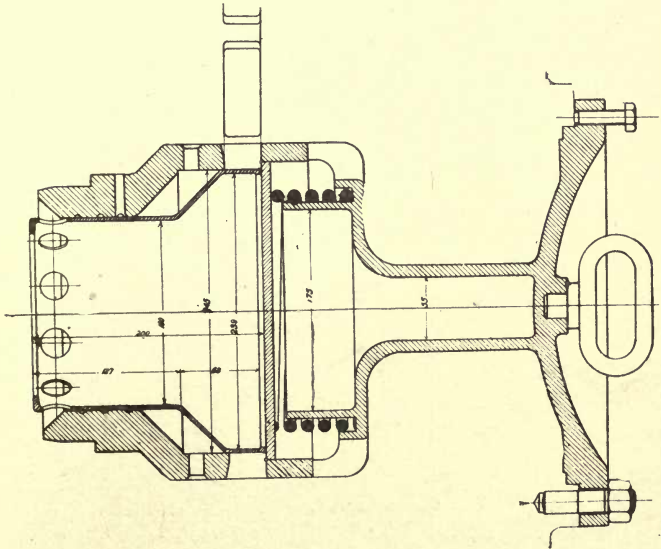

FIG. 58.

closed in the drawing, having been pushed against the plate of wrought iron, 8 mm. thick, by the piston at the end of its stroke. This plate is prevented from moving to the left by the ribs between the passages in the valve seat, and it is pressed against them by the spiral spring, which gives way when the valve is pushed against the plate. The spring is of 11 mm. diameter, and the diameter of its coil is 200 mm. The passages in the valve seat are 35 mm. (1.38 in.) wide, and the valve moving to the left opens them

fully. Once closed the valve is kept in that position, because the pressure in the cylinder is less than that in the valve chest directly the piston commences its return stroke. The latter pressure enters the cylindrical valve seat by means of the holes countersunk on the outside, and, acting on the annular area of the valve, forces it to the right.

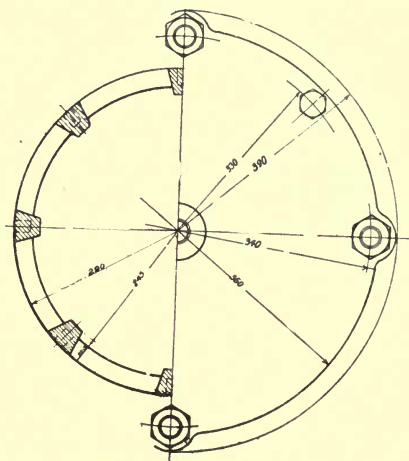

FIG. 59.

In order to cushion the valve when opening, these holes can be closed, if necessary, by screws, so as to throttle the out-flow of the air. As soon as the pressure in the cylinder becomes slightly greater than that in the valve chest the valve is forced to the left, and the passages opened. The spring is kept in place by the casting, which also forms the cover.

20. *Blast-furnace Blowing Engine, constructed by Messrs. Breitfeld, Danek, and Co., of Prag-Karolinenthal.*—Figs. 60, 61, and 62 show this engine in side elevation, front elevation, and plan. It was constructed for the Wilkowitz Ironworks, and is a compound-condensing engine, having steam cylinders 1,500 and 2,000 mm. (59.1 and 78.7 in.)

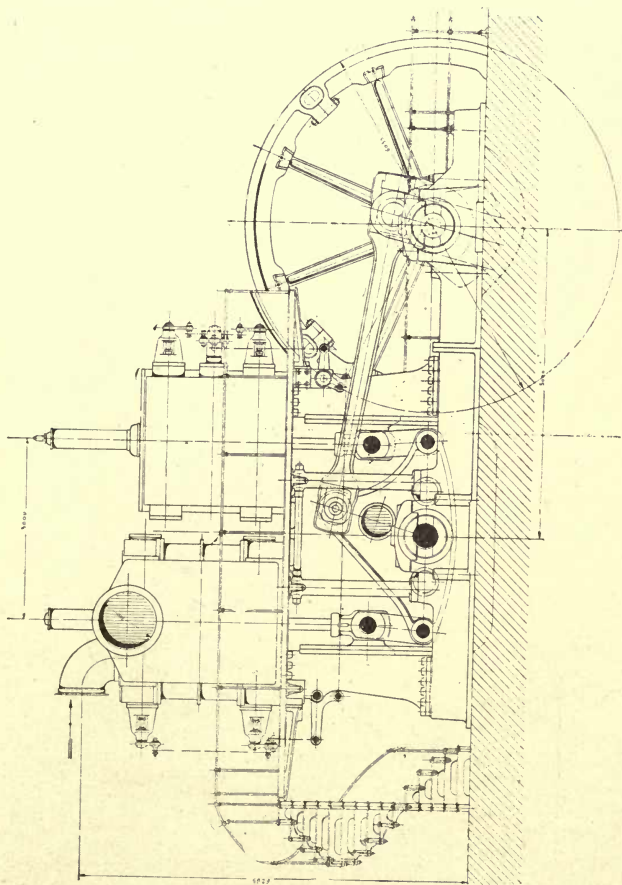

FIG. 60.

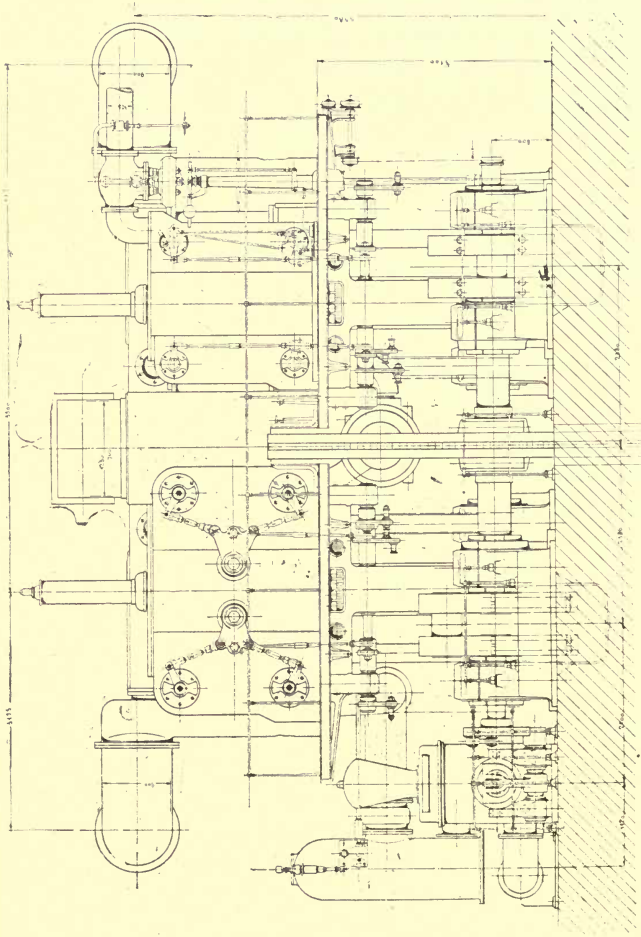

FIG. 61.



diameter, with blowing cylinders 2,400 mm. (94.5 in.) diameter, and stroke 1,300 mm. (51.25 in.). The speed is 45 to 65 revolutions, the boiler pressure 132 lbs., and that

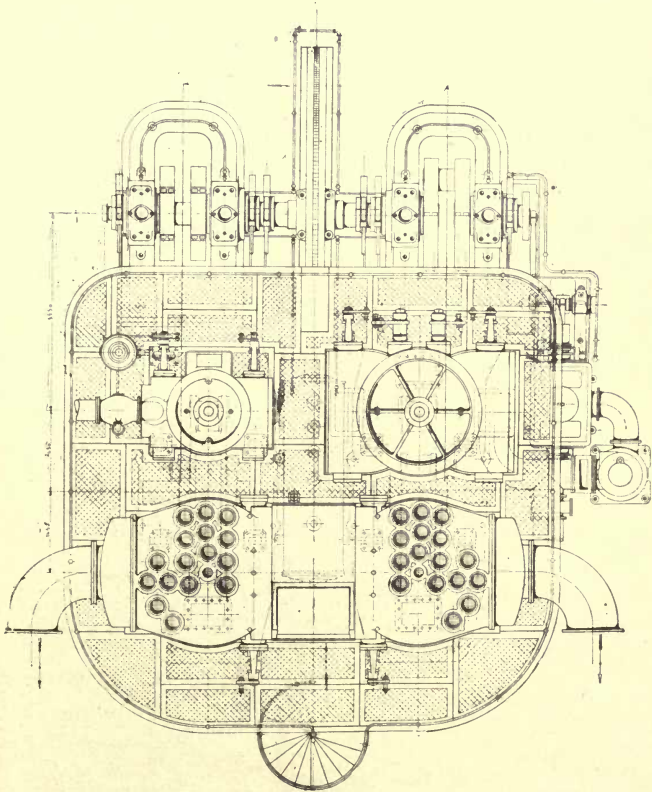

FIG. 62.

of compression 1.1 atmospheres by gauge. The discharge per minute is 1,000 to 1,444 c.m. (35,200 to 50,900 cubic feet) per minute, and the number of discharge valves in each cylinder end 16. The arrangement of the engine is peculiar,

but it combines the advantages of vertical and horizontal engines. Each steam cylinder drives a blowing cylinder by a lever beneath it, fig. 60, while the third arm of this lever is coupled to the connecting rod, which drives a crank. The shaft carries a flywheel in the middle, whose diameter is 6,030 mm. (237 in.), the radial width of rim 400 mm. (15 $\frac{3}{4}$  in.), and breadth 235 mm. (9.65 in.). The distance between the centres of the steam cylinders is 3,800 mm. (149.5 in.), and between each steam cylinder and the blowing cylinder that it drives, 2,900 mm. (114 in.) The air pump is to the right of the engine, and is driven by an overhung crank and oscillating lever at the end of the crank shaft. One of the discharge valves is shown in fig. 63. In a four hours' test the mean speed was 44 $\frac{1}{2}$  revolutions very nearly, the steam horse power 1576.85, and that of the blowing cylinders 1517.31, giving a mechanical efficiency of 96.22 per cent. The steam used per horse power hour was 15.1 lb. Unfortunately the pressure of the air is not given, and we cannot, therefore, find the total efficiency of the engine.

21. *500 Horse Power Double-acting Körting Gas Engine and Blowing Cylinder, constructed by the Siegener Maschinenbau Actien-Gesellschaft.*—The principal dimensions of this engine are :—

- Motor cylinder diameter, 635 mm. (26.87 in.)
- Stroke, 1,100 mm. (43.31 in.)
- Blowing cylinder diameter, 1,750 mm. (69 in.)
- Air pump diameter, 690 mm. (27.2 in.)
- Gas pump diameter, 750 mm. (29.5 in.)
- Stroke (about) 820 mm. (32.3 in.)

Mechanically controlled Corliss valves are used for admission of air to the blowing cylinder, the air entering as usual by a passage in the foundations. The discharge valves are of the Riedler-Stumpf type, which are closed by the piston, but are opened by the pressure of air in the cylinder. Fig. 64 is a sectional elevation, and fig. 65 a complete plan of the blowing cylinder. Owing to the fact that the gases from blast furnaces can now be employed to more advantage in driving gas engines than in burning them in boilers, the construction of the Körting gas engine, which is double

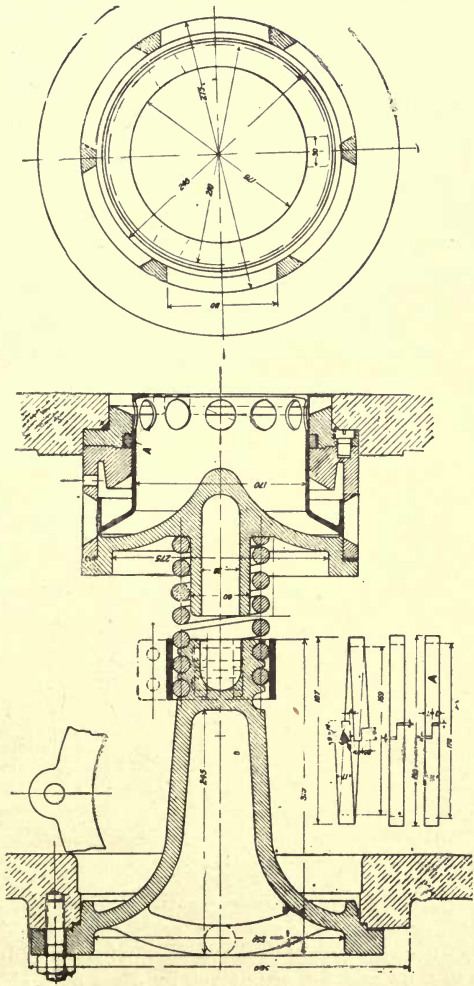

FIG. 63.

acting, and therefore very compact, is of interest in connection with the subject of blowing engines. We therefore give a description of this type of engine, for which we are indebted to Messrs. Fraser and Chalmers, of Erith.

Fig. 66 is a plan showing a section through the motor cylinder K, and the air and gas cylinders, L P and G P,

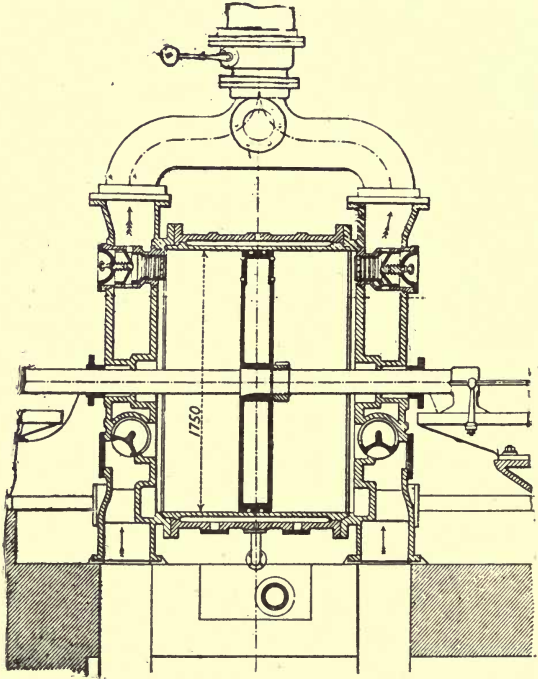

FIG. 64.

these being driven by a crank on the end of the engine shaft. An eccentric between the crank and the bearing drives the slide valves of these cylinders, while the admission valves E, figs. 67 and 68, are driven by cams on a side shaft running at the same speed as the engine. There is no

exhaust valve, but passages S, figs. 66 and 67, are uncovered at the end of the stroke, and the gases escape into a ring-shaped passage leading to the exhaust pipe at A. Before the exhaust passages are closed the admission valves open, and as the pressure in the pump cylinders is about 9 lb. per square inch, the fresh charge enters the motor cylinder,

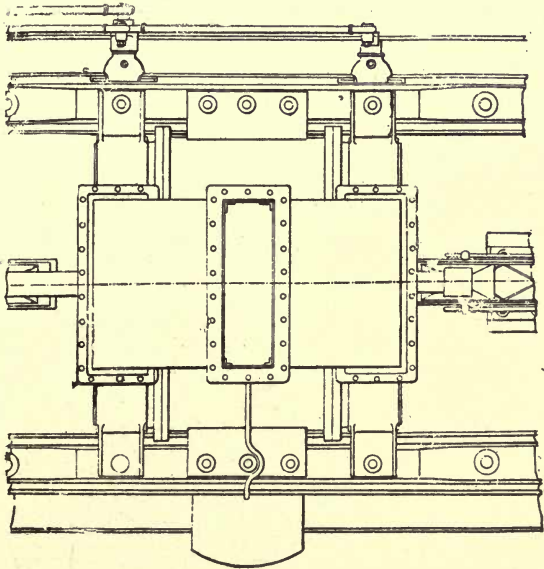

FIG. 65.

sweeping out the exhaust gases. Shortly after these passages are closed by the returning piston, the pistons of the gas and air pumps have reached their dead point. The supply of fresh mixture therefore ceases, the inlet valves close, and the charge in the cylinder is compressed, as shown by *ab* in the diagram, fig. 67; at the dead centre explosion *bc* occurs, followed by expansion *cd*, and exhaust *da* on the next stroke. A layer of pure air is sent between the burnt and the explosive charges, in order to prevent the new

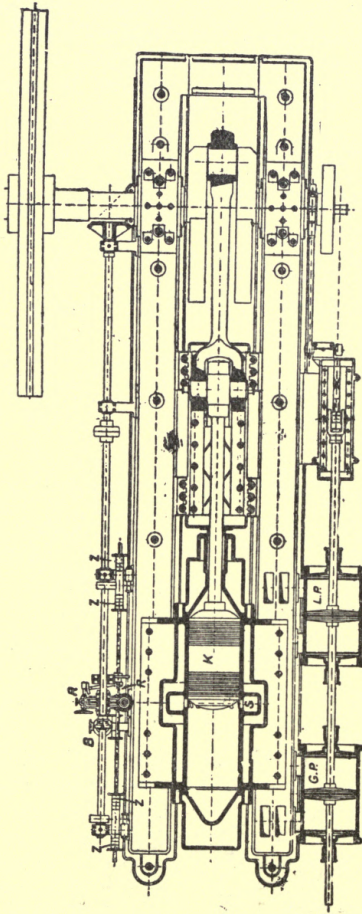

FIG. 66.

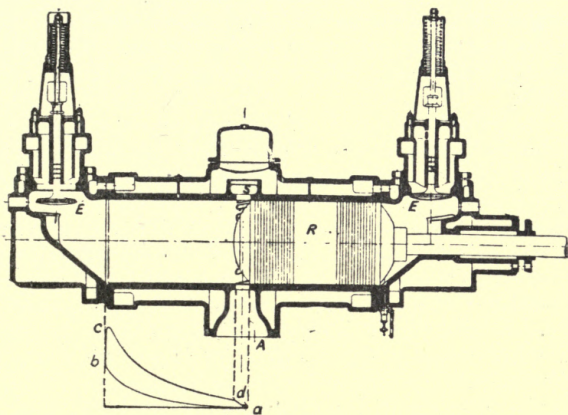

FIG. 67.

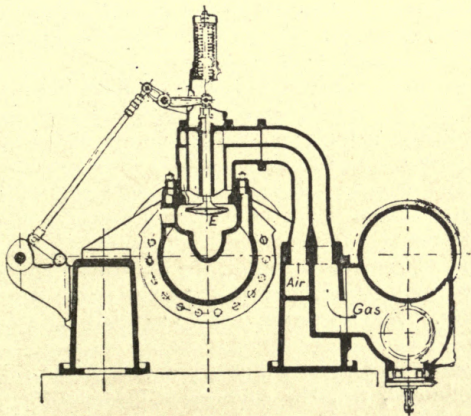

FIG. 68.

charge being mixed with the residues of the previous stroke, so that dangerous pre-ignitions are avoided. The pumps do not compress the charge, but only force it into the cylinder, delivering to the admission valve through separate channels, which are rather long, the gas and air being stored in these channels.

It is evident that such of the two gases will enter the cylinder first which fills the channels in the immediate neighbourhood of the admission valve at the moment when the valve is opened. Due to the setting of the slide valves of the air pumps separately, and at different angles of eccentric, the air pump takes in and discharges its full volume in the usual way, but in the gas pump the opening and closing of the valves only takes place after part of its stroke. During about the first half of its discharge stroke, the gas taken into the pump cylinder is passed back to the suction chamber which is in communication with it. Only during the last half of the discharge stroke the work of the gas pump actually begins, when connection between the suction and pressure chambers is closed. The gas pump then discharges at once to its full capacity for the remainder of its stroke. The air pump compresses the air contained in the cylinder from the commencement of the discharge stroke, and so air always enters the power cylinder ahead of the mixture of air and gas, and will always be found between the burnt and explosive charges.

It must be understood that the combustible mixture of gas and air is only formed at the exact moment of its entrance in the cylinder at E. The pure air entering first into the power cylinder does not mix with the combustible mixture on account of the special arrangement of the inlet bend. The charge is not diluted, and even a small charge can be ignited and burnt. The composition of the mixture of gas and air remains constant, the governor regulating the volume of the mixture, according to the power required for each stroke. The regulation can be effected in two different ways:—

1. The moment when the gas pump begins to discharge may be retarded, *i.e.*, the connection between the pressure chamber of the gas pump and the suction chamber remains



open for a longer period; the discharge into the power cylinder commencing later, and in lesser volume, the quality of the mixture remaining always uniform. This retardation is obtained by governing the gas slide valve similar to the governing of a locomotive, a method which is also adopted for blowing engines,

2. The second arrangement is that a connecting channel is formed between the pressure chamber of the gas pump and the suction chamber, the area of which is opened or closed more or less by a throttle valve operated by the governor. The discharge of the pump then remains constant, but when this channel is partly opened, some of the gas from the pressure channel returns into the suction chamber during the suction stroke, and in the same proportion the gas is replaced in the pressure channel by pure air from the air pump. When the admission valve to the power cylinder opens, more pure air is admitted, followed by so much less combustible mixture, according to the volume of gas pressed back in the channel, the gas pump having first to replace this volume before the combustible mixture can be formed. The governor, therefore, regulates the volume of gas passing back through the channel, and the volume of gas replaced by air. The amount of mixture formed therefore depends upon the extent of opening of the throttle valve, according to the position of the governor, and so any intermediate output between full and no load can be obtained. The closing of the admission valves *E* is effected by a spring. The charge is ignited by magnetic inductors, and in order to secure a regular ignition of a charge which is at one time large and at another small, several igniters are provided for viz., four—two at each side of the cylinder, one close to the inlet valve, the other one near the end of the piston in stroke. The inductors are operated by a small separate shaft which is driven by gears from the main shaft, by shifting which the moment of ignition can be accelerated or delayed according to the gas used without having to stop the engine. When starting the engine it is further possible to arrange for the ignition not to take place till after the dead point which insures the engine starting very slowly without risk of too early ignition. The engine is

started by an independent compressed air arrangement. For engines directly coupled with blowing cylinders a pressure of about 150 lb. is sufficient; for other engines 90 lb. to 120 lb. is enough. This is of course of the greatest importance, as the pressure of the compressed air never exceeds that of the compression with which the engine works, viz., from 150 lb. to 180 lb. It is therefore absolutely impossible for the compressed air to get into the power cylinder when the piston is near its dead point, where the compression of the charge is at its highest and the ignition takes place. There is therefore no chance of the ignition being delayed or failing altogether. The compressed air is distributed by a slide valve, similar to those used in steam engines, to the left and right hand side of the cylinder; two cylinder volumes of air are generally sufficient to start the engine easily. The starting arrangement itself consists of a small compressor with air vessel, driven preferably by electro-motor. In engines working with a high compression of the charge before its ignition, it is of the greatest importance to cool the charge, so as to avoid both too high compression and too high temperature of combustion. The surface of the combustion chamber is therefore enlarged by ribs or by special pockets through which water circulates. The piston is cooled by water entering through the hollow piston rod, and water also circulates round the glands of the valve boxes. In keeping the piston cooler than the cylinder itself, the expansion of the former is kept within reasonable limits, and a satisfactory working of the engine is assured. The cylinder is provided with oil drain valves, acting at the same time as safety valves. The interior of the cylinder is kept free from any incrustation. No oil crusts will be found near the exhaust slots, as the burnt charge is driven out with considerable force alternately from the right and left side. The great advantage of such an arrangement is obvious, considering that in all engines exhausting only from one side early ignitions and explosions are frequent. The low temperature of the piston also prevents the evaporation of the oil at the edges of the slots. The advantages claimed for this type of gas engine are smallness of size, as steady running as in a steam engine, absence of exhaust valves,

avoidance of free ignition, and the fact that the mixture of gases takes place only at the inlet valve. Fig. 69 shows six indicator diagrams from an engine the diameter of whose piston is  $29\frac{1}{2}$  in., stroke  $51\frac{1}{4}$  in.

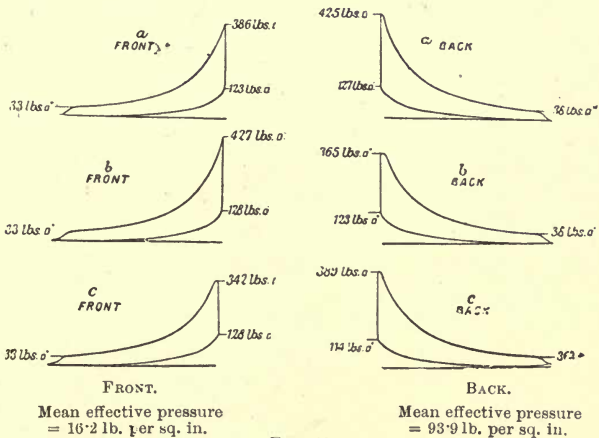

FIG. 69.

22. *Vertical Blast-furnace Blowing Engine, constructed by the Elsädischen Maschinenbau-Gesellschaft in Mulhausen.\**

This engine is cross compound and condensing, with cranks at right angles, the blowing cylinders being above the steam. The leading dimensions are as follow:—

Diameter of H.P. cylinder .....	1,200 mm. (47.25 in.)
Diameter of L.P. cylinder .....	1,870 mm. (73.6 in.)
Diameter of blowing cylinders..	2,000 mm. (78.7 in.)
Stroke .....	1,500 mm. (59.1 in.)
Revolutions .....	25 to 50.

Each steam cylinder is carried by a pair of bored frames, supported by a cast-iron bed plate, figs. 70, 71. The bearings are lined with white metal, and the diameter of the journals is 520 mm. (20.5 in.), their length being 840 mm.

\* Stahl und Eisen, June 15th, 1899.

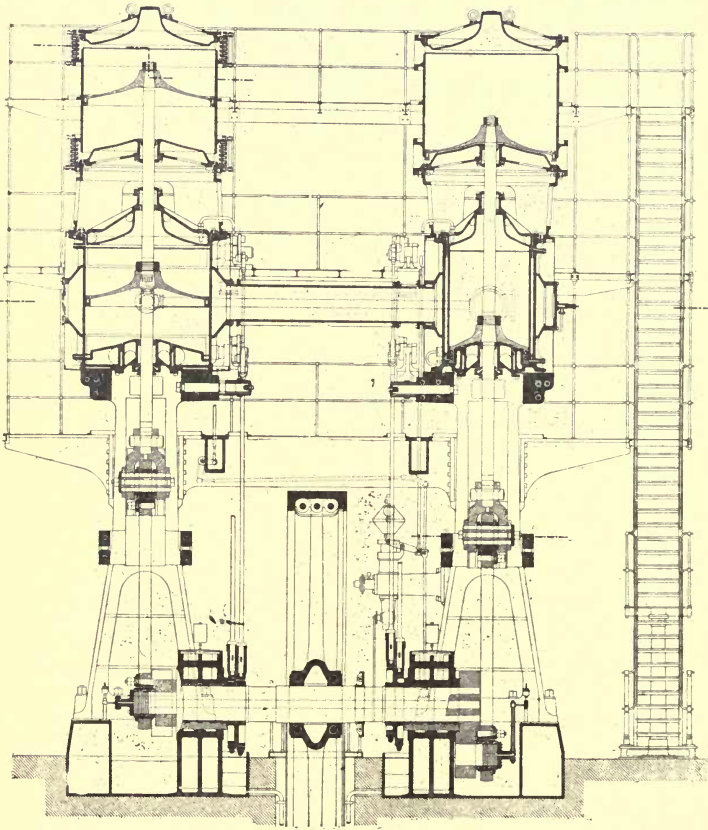

FIG. 70.

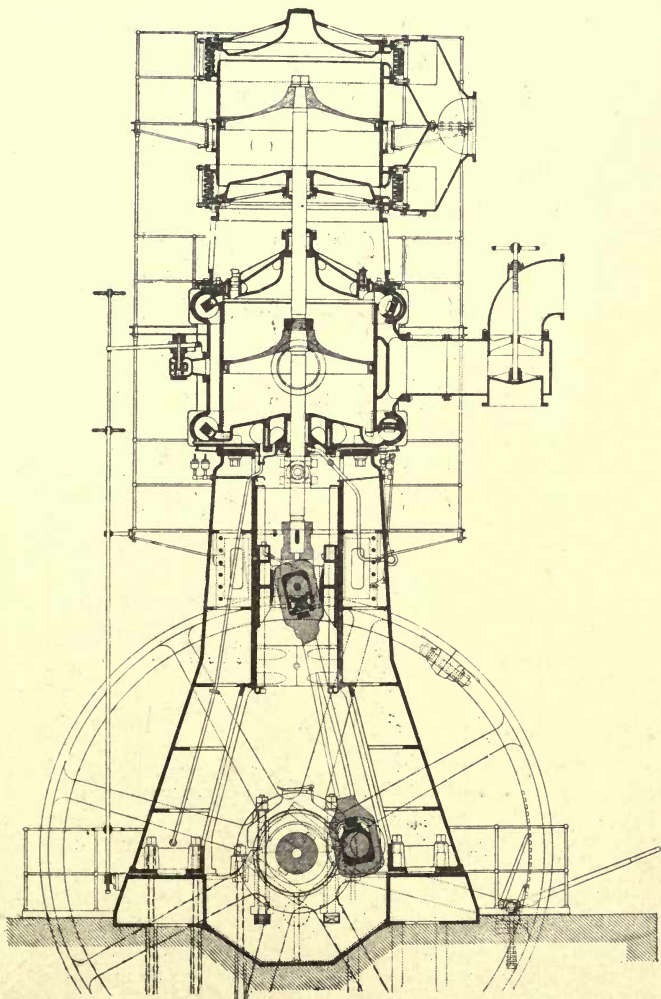

FIG. 71.

(33·1 in.); the crank pins are 330 mm. diameter (13 in.), and of the same length. The shaft is hollow, and its internal diameter is 100 mm. (3·94 in.). The flywheel has a diameter of 6 metres (236 in.), and weighs about 36 tons. The steam cylinders have Corliss valves, which can cut off between 0 and 60 per cent of the stroke. The governor controls the cut-off in both cylinders, in order to equalise their power.

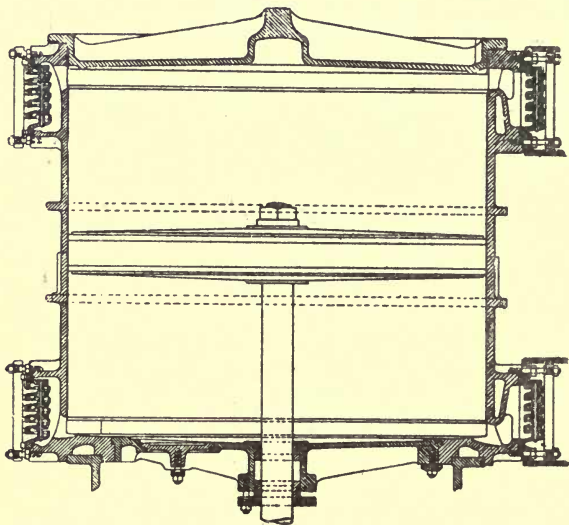

FIG. 72.

The steam cylinders and their ends are jacketed. All four pistons are of cast steel, and have packing rings in two parts. The engine can, if necessary, be started by admitting steam direct to the low-pressure cylinder. The distance pieces between steam and blowing cylinders are arranged to allow access to the stuffing boxes. It will be seen in figs. 70, 71, that the steam piston, with cylinder cover and blowing cylinder bottom, can be drawn upwards through the latter cylinder, or, by taking off the covers, the pistons can be examined. In figs. 72—75 are shown the blowing cylinder

and valves to a larger scale. These valves permit of high piston speeds without lessening the volumetric efficiency by an increase of the clearance; they are also easily accessible and removable. Suction valves are shown in fig. 73, and discharge in fig. 75. As seen in fig. 74, about a third of the circumference is given up to the discharge and the remainder to the suction valves. They consist of discs A of steel plate upon a central spindle B, which is fitted in a cast-iron frame which has the cross section shown at S S, and forms the valve seats. Each frame has four spindles—see the left of

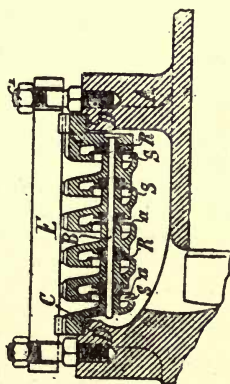

FIG. 73.

fig. 74—and each spindle carries five valves. Above each valve is a spiral spring R, which rests upon the valve beneath, and fits into a hollow space in the seat above. Each frame is held in place by a metal ring E, which is fastened by screws F F. The wear of valves and spindles is small, repairs are easily effected, and a high speed is possible owing to the small stroke of the valves. The piston area is  $7\frac{1}{2}$  times the suction-valve area, and  $12\frac{1}{2}$  times that of the discharge. At 50 revolutions the velocity through the suction valves is 19 m. (62.2 ft.) per second, and 31 m. (101.5 ft.) per second through the discharge valves.

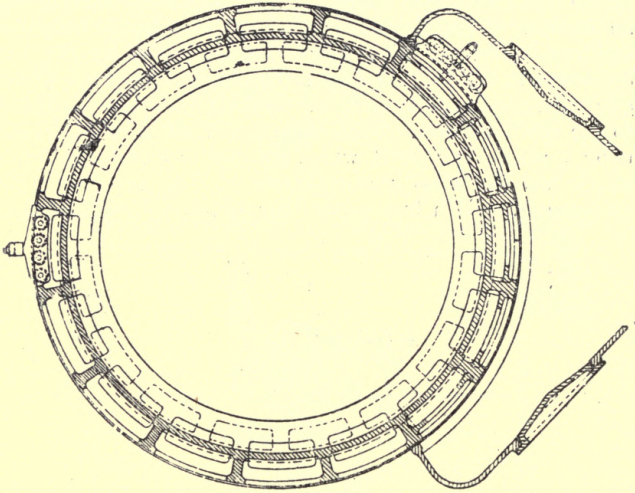

FIG. 74.

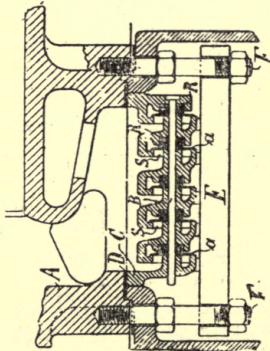

FIG. 75.



23. *Vertical Compound Blowing Engine, constructed by the Lillieshall Company, of Oakengates, Shropshire, for the Priors Lee Works.*—This engine is of the compound vertical

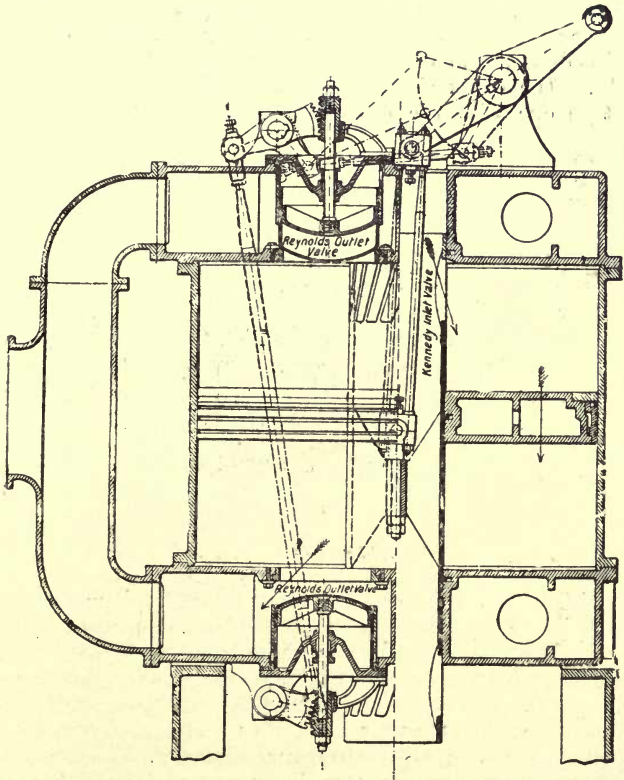

FIG. 76.

type, the blowing cylinders being above the steam. The steam pressure is 100 lb., the air pressure 10 lb. to 15 lb. per square inch, and they will deliver at 45 revolutions, their normal speed, 41,500 cubic feet of air per minute. They

can and have run at 60 revolutions. The steam cylinders are 42 in. and 70 in. diameter, while the blowing cylinders are 95 in., with a stroke of 5 ft. The steam-valve gear is of the Corliss type, there being two eccentrics, one for working the steam and the other the exhaust, for each cylinder. The air pump is single-acting, 38 in. diameter and 36 in. stroke, and is driven from the low-pressure piston rod by lever and links. The crank shaft is of forged steel, the pins being cast in one with the cranks, and having a diameter and

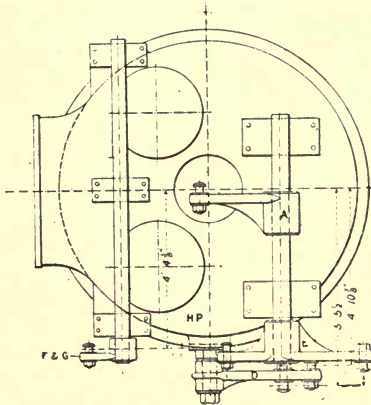

FIG. 77.

length of 12 in. The crank journals are 18 in. diameter and 30 in. long; the body of the shaft is  $19\frac{1}{2}$  in. diameter and the flywheel seat  $21\frac{1}{2}$  in. The flywheel is 20 ft. diameter and weighs about 40 tons. The engine is specially interesting, because of the valve gear of the blowing cylinders, which enables it to run at such a high speed. The inlet valves are Kennedy's patent, and the discharge Reynolds'. The manner in which they are worked is shown in figs. 76 and 77, for which we are indebted to the Lillieshall Company. In the latter, D is a lever pivoted near the lower end of the cylinder and oscillated by an eccentric on the crank shaft. A connecting rod transmits its motion to the right end of the lever B, whose shaft operates the lever A that works Kennedy's

inlet valve. It will be seen from fig. 76 that this is a trunk passing through but not moving with the blowing piston, which has two rods, one in front and one behind it, neither of which are shown in the figure. Ports are cut spirally in each end of this trunk, and admit the air at the right moment, cutting off at the end of the stroke. In the figure, the piston is moving down and the upper ports are admitting air, and it will be seen that three springs prevent leakage at the cylinder covers and the piston. A link connects the left end of lever B with the crank of the left-hand shaft, fig. 77. This shaft works the delivery valves, two at each end of the cylinder, by means of arms having toothed sectors on their ends. The upper valves are closed and are kept to their seats by the air pressure, and when the piston rises it will not rise until the pressure in the cylinder has reached that in the discharge; but near the end of the stroke the piston whose spindle is actuated by the toothed sector will bring it close to its seat, so that it will close without shock.

24. *Compound Blast-furnace Blowing Engine, constructed by Messrs. Davy Bros., of Sheffield.\**—Fig. 78 is a sectional elevation through the low-pressure steam and one of the blowing cylinders. The steam cylinder is above the blowing cylinder, an unusual arrangement. The diameters of the steam cylinders are 48 in. and 84 in., and those of the blowing cylinders 84 in. The stroke is 54 in., the greatest possible with the very limited height of the engine-house. Had it not been for this a stroke of 6 ft. would have been preferred. The steam cylinders are designed for a 12 lb. blast, but 15 lb. can be obtained if necessary, the steam pressure being 75 lb. The maximum speed is 50 revolutions, and the capacity of the cylinders is then 34,632 cubic feet of air per minute. Both high and low pressure cylinders have piston valves with internal expansion valves; the high-pressure cylinder has one and the low-pressure two valves, all of the same size. The expansion valves are adjustable by hand from the level of the floor. The steam pistons are conical, and are fitted with Mather and Platt's packing rings and springs. The air pistons are fitted with junk rings and

---

\* *Engineering*, March 17, 1899.

an improved form of metallic packing. The clearance is little more than 3.6 per cent of the cylinder volume, which is very good considering the comparatively short stroke.

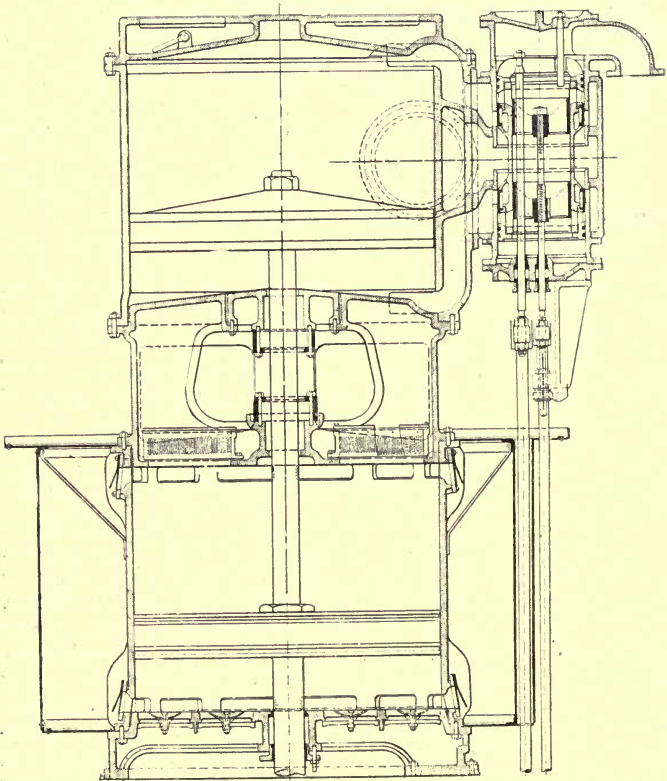

FIG. 78.

The inlet valves are on the cylinder ends, and the discharge valves are arranged circumferentially round the top and bottom of the cylinders. The valves are of leather, and

the area through the inlet valves is a little more than one-fifth of the cylinder area, so that the suction line very nearly coincides with the atmospheric. The crank shaft is of steel, with a diameter of 18 in.; the cranks are 120 deg. apart, so that the engine can be started in any position, and it may be remarked here that an arrangement such as this gives a more uniform turning moment, and therefore a lighter fly-wheel can be used. The weight of the flywheel is 35 tons, and its diameter 16 ft.

25. *Vertical Blowing Engine, by the same firm.*—Figs. 79, 80, 81, for which we are indebted to Messrs. Davy Bros., show a front and two side elevations of this engine. It was built for the Acklan Works of the North-Eastern Steel Company, and another is in course of construction. The steam cylinders are above the two blowing cylinders, the former having diameters of 48 in. and 90 in., the latter being 90 in. diameter. The stroke is 72 in. At 50 revolutions, 70 lb. steam pressure, and 10 lb. vacuum the engine will deliver 50,000 cubic feet of air per minute. It is constructed for a steam pressure of 100 lb. and a corresponding increase of blast pressure. At this pressure it will indicate 3,800 horse power.

The steam cylinders are fitted with double-ported Corliss valves, the cut-off being controlled by a high-speed spring governor, which is driven by friction gear. The speed of the engine can be regulated from 20 to 50 revolutions per minute by means of a small hand wheel, which controls the ratio of gear between the engine crank shaft and the governor. As shown in fig. 80 each cylinder has two eccentrics. One of these drives the exhaust valves by means of a wrist plate, and the other actuates the steam valve. This permits of a cut-off from the beginning to nearly the end of the stroke, which is not possible when only one eccentric drives both valves. The opening and closing of the exhaust valves is very rapid, and when once closed they remain almost stationary upon their seats until they are opened again. This is effected by the arrangement of the arms of the wrist plate, the connecting links, and valve levers. By this means the work wasted by valve friction, and the consequent wear, are reduced to a minimum. The steam valves

are closed by means of small steam cylinders, in place of the usual spiral springs, which are more or less liable to break,

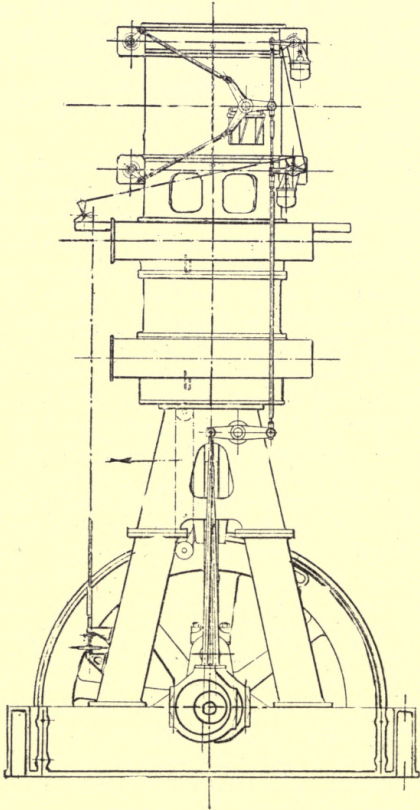

FIG. 79.

sometimes with disastrous results. The engine is fitted with a starting valve, and will start from any position against the full blast pressure. The cranks are at 120 deg., as in the

last engine described. The air cylinders are fitted with mild steel disc suction and delivery valves. These are

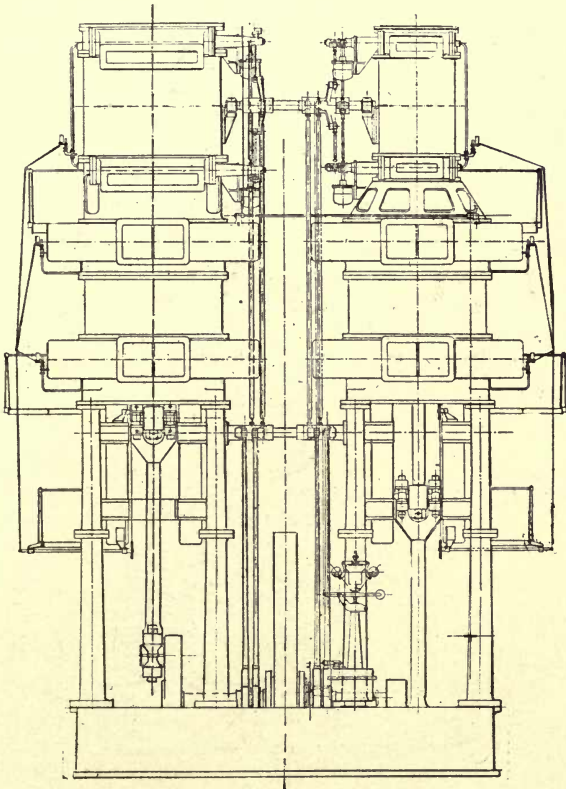

FIG. 80.

shown in fig. 82, which is a sectional elevation of the blowing cylinder, whose thickness is 2 in. There are 24 suction and 24 delivery valves at each end, of 10 in. diameter. The

piston has two packing rings, and there is a space between the piston and the rings which is filled with elastic asbestos

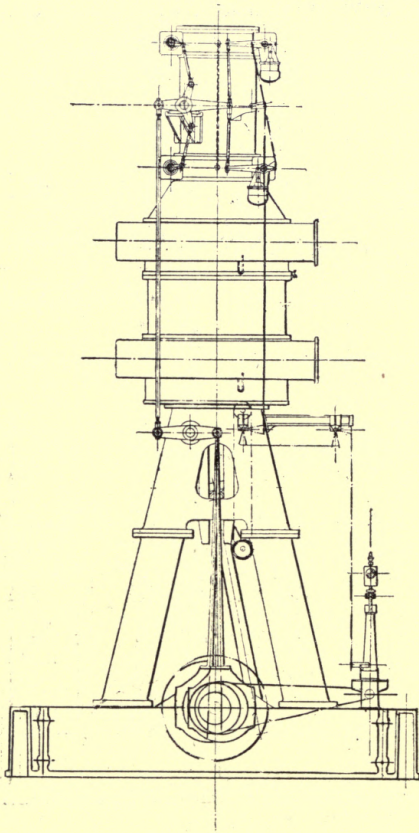

FIG. 81.

packing, the whole being secured in place by a junk ring in six segments. By this arrangement the whole of the packing can be withdrawn through a small manhole in the top cover



of each air cylinder. The A frames that carry the cylinders are 2 in. thick.

The rigidity and construction of the bed-plate is such that the engine would not be thrown out of truth even if a con-

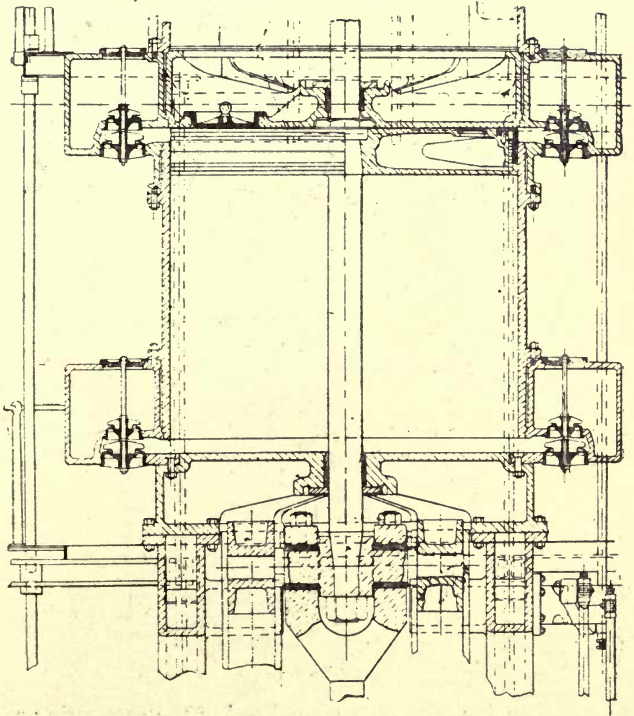

FIG. 82.

siderable settlement of the foundation took place. This is of importance, as the ground is of a very boggy nature. It is of box section, 4 ft. deep, 2 in. general thickness, increased to 3 in. at the crank-shaft pedestals. The crank shaft is of forged Siemens steel. The journals are 20 in. diameter and

3 ft. long; the crank pin is 12 in. diameter and 15 in. long. The diameter of the shaft at the flywheel is 25 in., and the length of the boss of the flywheel 27 in. The flywheel is 20 ft. diameter and weighs about 40 tons, one half of the rim being hollow to balance the moving parts. The steam piston rods are  $7\frac{1}{2}$  in. diameter, and the blowing piston rods

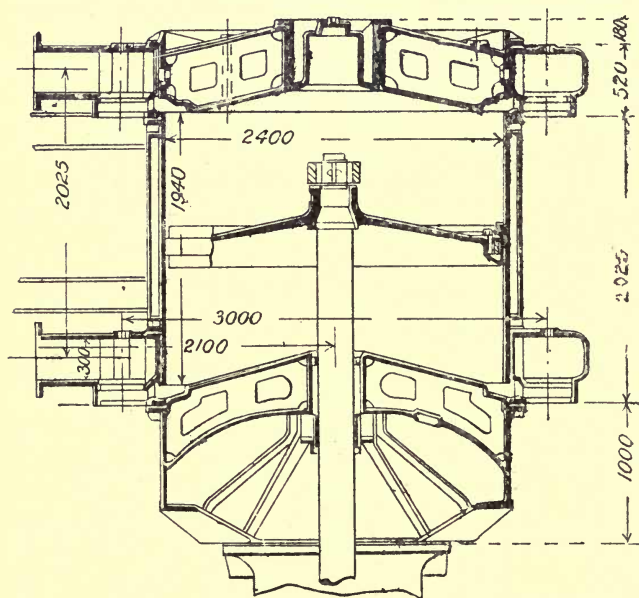

FIG. 83.

$8\frac{1}{2}$  in. The diameter at the small end of the connecting rod is  $8\frac{3}{4}$  in., and at the large end 10 in. The upper end of the connecting rod is forked and has T ends, caps, and brasses. Each end of the crosshead gudgeon is  $8\frac{1}{2}$  in. diameter, and the same length. There are two guide blocks, 24 in. by 12 in. The centres of cylinders are 15 ft. apart. The whole engine weighs about 400 tons. A test of these engines, with indicator diagrams, will be given later.

26. *Blast-furnace Blowing Engine, constructed by the Kölnische Maschinenbau-Actien-Gesellschaft, of Köln-Bayenthal.*—Figs. 83, 84, 85 show a sectional front elevation, a side elevation, and a plan in section through the valve passages of the cylinder of a vertical blowing engine whose leading dimensions are—

Diameter of high-pressure cylinder.	1,600 mm. (63 in.)
Diameter of low-pressure cylinder..	2,350 mm. (92·5 in.)
Diameter of each blowing cylinder.	2,400 mm. (94·5 in.)
Stroke .....	1,800 mm. (70 8 in.)

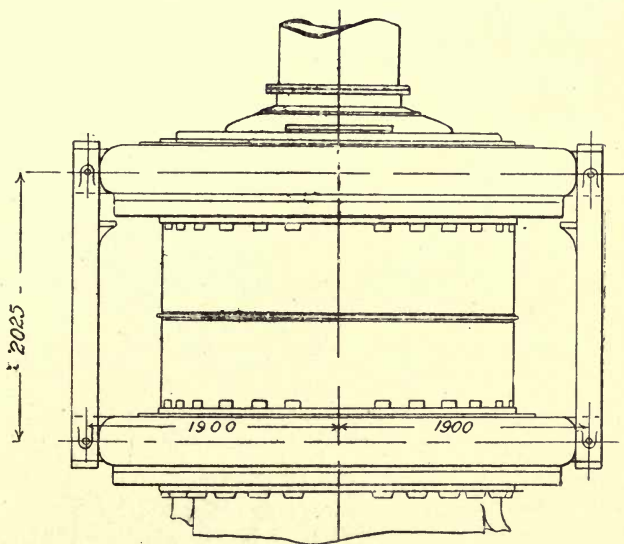

FIG. 84.

The valves of the blowing cylinders are of the same type as those in the last engine. From the delivery valves the air passes into ring-shaped passages, whose section gradually increases to a rectangular discharge of 300 mm. by 1,510 mm. (11·82 in. by 59·5 in.). Both cylinders deliver into a cylindrical receiver of about 1,700 mm. diameter and 3,000 mm.

length (67 in. and 118·2 in.), whose discharge pipe is 900 mm. diameter ( $35\frac{1}{2}$  in.). Both steam cylinders have piston valves, in which work expansion valves; the diameter of the high-pressure valve is 840 mm. (33·1 in.), and that of the low-pressure 1,230 mm. ( $48\frac{1}{2}$  in.). The diameter of the crank shaft journals is 750 mm. ( $29\frac{1}{2}$  in.), and the length 1,100 mm. (43·4 in.); at the flywheel the diameter of shaft is 850 mm. (33·5 in.). The cranks are overhung, and the crank pins

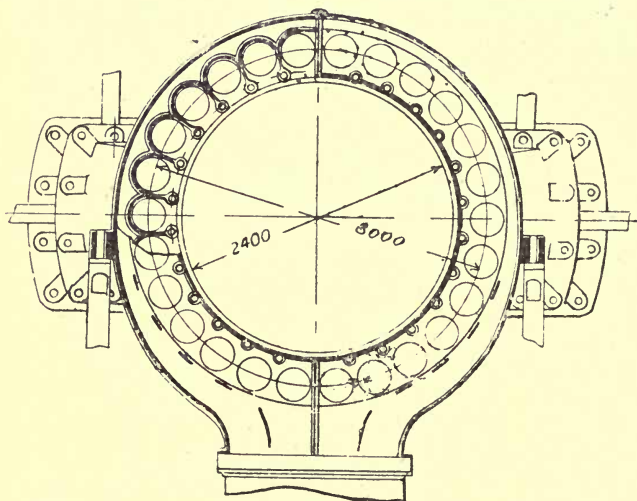

FIG. 85.

are 450 mm. diameter ( $17\frac{3}{4}$  in.) and 510 mm. long (20·1 in.). The diameter of the piston rods is 250 mm. (9·85 in.), as also that of the tail rods; at the small end of the connecting rods the diameter is 250 mm., and at the large end 350 mm. (13·8 in.). The length of the connecting rod is 4,000 mm. (158 in.), and the distance between centres of cylinders is 6,500 mm. (256·5 in.). The diameter of the flywheel is 8,000 mm. (315 in.), its rim is 360 mm. broad (14·2 in.), and its radial depth is 420 mm. ( $16\frac{1}{2}$  in.). The normal discharge of this engine is 1,600 cubic metres per minute, or 56,500

cubic feet, and its maximum output 1,920 cubic metres, or 67,750 cubic feet of free air. The normal pressure is 1 atmosphere, which may be raised to 1.8. The corresponding revolutions are 50 and 60 per minute. The boiler pressure is  $6\frac{1}{2}$  atmospheres, about 95 lb., and the engine is condensing.

27. *On the Efficiency of Blast-furnace Blowing Engines.*—If we assume a mechanical efficiency of 85 per cent, and calculate the air efficiency by the formula

$$\eta_3 = \frac{2.3 \log \frac{p_1}{p_2}}{\frac{n}{n-1} \left\{ \left( \frac{p_1}{p_2} \right)^{\frac{n-1}{n}} - 1 \right\}}$$

we obtain for the three exponents

$n = 1.25$	$1.3$	$1.408$
$\eta_3 = .967$	$.952$	$.94$

if  $\frac{p_1}{p_2} = 1.5,$

and multiplying these by the mechanical efficiency of 85 per cent, we get the three values 82.25, 81, and 80 per cent as the total efficiency. The above, however, neglects the fall of the suction line and the rise of the discharge line due to valve resistance. The following examples are taken from "Die Gebläse," by Von Jhering, Table I., p. 84, in which the dimensions, power, and delivery of a number of blast furnace and Bessemer blowing engines are given:—

Cubic feet per minute	12,000	17,900	28,900	31,700
Absolute pressure of air in atmospheres...	1.4	1.33	1.41	1.43
Indicated horse power	532	453	770	867
Total efficiency per cent	48.5	72.1	82.6	83.6

These last are calculated as follows:—

The useful horse power

$$U = \frac{144 p_2 v_2 \text{ hyp. log } \frac{p_1}{p_2}}{33000}$$

where  $v_2$  = cubic feet per minute,  $p_1$  = absolute pressure of compression, and  $p_2 = 14.7$  lb.

In the first case

$$U = \frac{144 \times 14.7 \times 12000 \times 2.3 \times \log 1.4}{33000} = 258.$$

Hence the total efficiency

$$\eta_1 = \frac{258}{532} = 48.5 \text{ per cent.}$$

This is certainly below what could be obtained from this engine. The average of the four results is 71.7, and is probably very near what we might expect from a blowing engine. We have already obtained an efficiency of 69 per cent for one of these engines in Section 16. The following figures are obtained from the above-mentioned work, and are from a test made with a beam engine. The indicated horse power was 332, that done in the blowing cylinder 281.3, so that the mechanical efficiency was nearly 85 per cent (including the work done on the feed pumps, 88 per cent). The piston area was 6.38 square metres, and the piston speed 1.1678 metres per second, so that the number of cubic feet swept out by the piston per minute was 15,800. The pressure to which the air was compressed was 1.304 atmospheres absolute, and if we assume the volumetric efficiency to be unity, the useful horse power was

$$U = \frac{144 \times 14.7 \times 15800 \times 2.3 \times \log 1.304}{33000} = 269$$

giving an air efficiency of

$$\eta_3 = \frac{269}{281.3} = 95.6 \text{ per cent,}$$

and a total efficiency of

$$\eta_1 = \frac{269}{332} = 81 \text{ per cent.}$$

Fig. 86 shows the indicator diagrams of the steam cylinders, and fig. 87 those of the blowing cylinders, of the large

compound condensing blowing engine described in Section 25. The diameters of the steam cylinders are 48 in. and 90 in., and those of the blowing cylinders are 90 in., the stroke

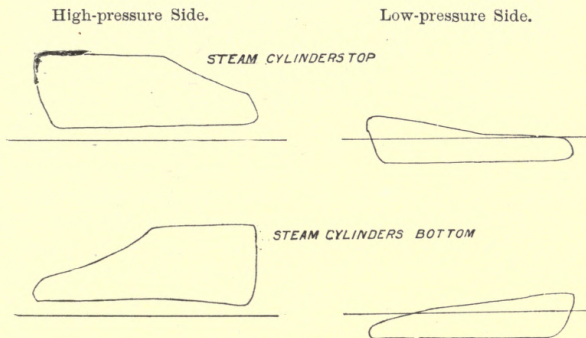

FIG. 86.

being 72 in. The diagrams were taken on November 25th, 1900. The steam pressure in the engine-house was 76 lb. by gauge, the vacuum 19 in., and the speed 35 revolutions.

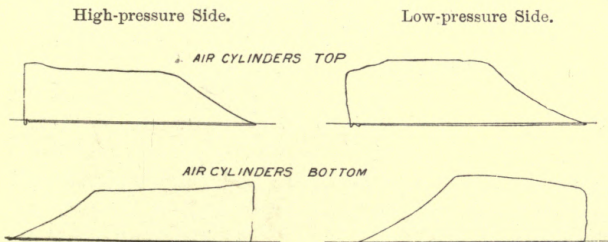

FIG. 87.

The greatest pressure in the high-pressure cylinder was 66 lb. above the atmosphere. The peculiar shape of the discharge lines on the air diagrams is due to the fact that

other engines were pumping into the air mains at the same time. We find from the diagrams—

High-pressure cylinder, M.E.P. 41·75,	
Indicated horse power.....	960
Low-pressure cylinder, M.E.P. 9·215,	
Indicated horse power.....	746
Two blowing cylinders, M.E.P. 9·71,	
Indicated horse power of both .....	1,570

This gives a mechanical efficiency of 92 per cent. The ideal horse power required to compress isothermally is obtained as follows. Measurement from the diagrams shows that the volumetric efficiency is 96·75 per cent, and the mean pressure at the end of the four strokes is 12 lb. above the atmosphere. Assuming this as the mean pressure to which the air is compressed, the ideal horse power is—

$$U = \cdot 9675 \times 2 \times \frac{14 \cdot 7 \times \cdot 7854 \times 90^2 \times 6 \times 70 \times \text{hyp. log } \frac{26 \cdot 7}{14 \cdot 7}}{33000} = 1365.$$

The air efficiency is therefore

$$\eta_2 = \frac{1365}{1570} = 87 \text{ per cent,}$$

and the total efficiency is

$$\eta_1 = \frac{1365}{1706} = 80 \text{ per cent.}$$

The engines are fitted with Crewe and Davy's patent radial trip gear, which enables steam to be cut off from the commencement to nearly the end of the stroke, so that considerably more power can be obtained. Such gear as this is of the utmost importance in case an extra pressure of blast is required, which is generally the case when the steam pressure is at its lowest.

28. *Bessemer Blowing Engines.*—These engines work at a higher pressure than those for blast furnaces. The pressure above the atmosphere is from 22 lb. to 30 lb., or about



$1\frac{1}{2}$  to 2 atmospheres. The following is a test of one of these engines, whose leading dimensions are—

Diameter of steam cylinder .....	1,255 mm. (49.4 in.)
Diameter of blowing cylinder.....	1,410 mm. (55.6 in.)
Stroke .....	1,410 mm.

The speed was 40 revolutions, and the suction pressure 13.8 lb. per square inch. The indicator diagram shows that 95.3 per cent of the cylinder volume was filled with fresh air each stroke at this pressure, so that the volumetric efficiency

$$\eta_3 = 95.3 \times \frac{13.8}{14.7} = 89.7 \text{ per cent.}$$

The indicated horse power from the blowing cylinders was 1,010, and that of the steam cylinders 1,152. The mechanical efficiency was therefore 87.6 per cent. The absolute pressure to which the air was compressed was 46.3 lb., and ideal horse power necessary was—

$$U = \frac{144 p_2 v_2 \text{ hyp. log } \frac{p_1}{p_2}}{33000}$$

$$= \frac{2 \times 14.7 \times .897 \times .7854 \times (55.6)^3 \times 80 \times 2.3 \log 3.15}{12 \times 33000} = 825,$$

so that the total efficiency

$$\eta_1 = \frac{825}{1152} = 71.6 \text{ per cent,}$$

and the air efficiency

$$\eta_2 = \frac{825}{1010} = 81.75 \text{ per cent.}$$

Measurements from the diagram show that the fresh volume of air drawn in per stroke was 2.462 times its volume when compressed from 13.8 lb. to 46.3 lb. absolute, hence the exponent of compression

$$n = \frac{\log 46.3 - \log 13.8}{\log 2.462} = 1.345.$$

Messrs. Breitfeld, Danek, and Co., of Prag-Karolinenthal, have kindly supplied me with five sets of diagrams of a Bessemer blowing engine. The leading dimensions are—

High-pressure cylinder diameter .....	950 mm.
Low-pressure cylinder diameter.....	1,400 mm.
Blowing cylinder diameter .....	1,350 mm.
Stroke .....	1,500 mm.
Revolutions .....	50

The fifth set give the following results:—

Indicated horse power of steam cylinders...	1,340
Mean pressure of blowing cylinders.....	18·37 lb.
Horse power of both.....	1,220
Mechanical efficiency .....	91·1 per cent.

The mean discharge pressure was 3·14 atmospheres absolute, and the volumetric efficiency 86 per cent. The mean pressure with isothermal compression for this is 14·4 lb. This gives

$$\eta_2 = \frac{14\cdot4}{18\cdot37} = 78\cdot4 \text{ per cent,}$$

and the total efficiency is

$$\eta_1 = 78\cdot4 \times \cdot911 = 71\cdot3 \text{ per cent.}$$

29. *Bessemer Blowing Engine, constructed by the Kölnische Maschinenbau-Actien-Gesellschaft, of Köln-Bayenthal.*—Fig. 88 is an elevation, fig. 89 a sectional plan, fig. 90 a complete plan, and fig. 91 an end elevation partly in section of the blowing cylinder of a horizontal engine. The leading dimensions of the engine are—

High-pressure cylinder diameter ...	1,300 mm. (51·2 in.)
Low-pressure cylinder diameter ...	2,000 mm. (78·8 in.)
Diameter of each blowing cylinder.	1,800 mm. (71 in.)
Stroke .....	1,700 mm. (67 in.)

The blowing pistons are, as usual, driven from the tail rods of the steam pistons. The valves are set in two rings at the ends of each cylinder, the valves themselves being shown in

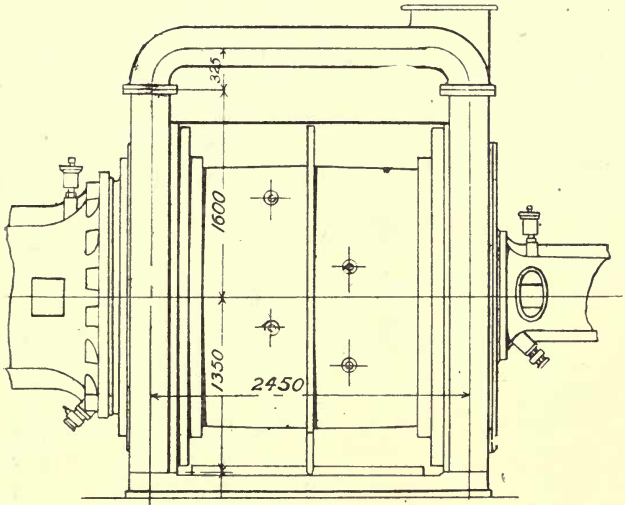

FIG. 88

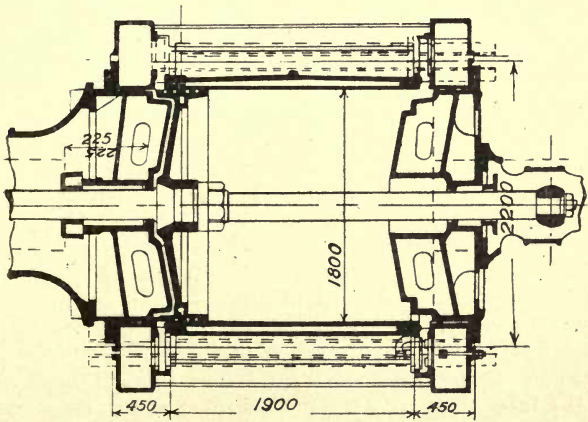

FIG. 89.

fig. 92. Each valve seat holds four delivery or four suction valves, the former being nearer the cylinder ends, and discharging into a passage of rectangular section whose breadth radially increases from the bottom to the top, see fig. 91. The valves are pressed on their seats by spiral springs, and the valve seats are held to the casting by a central bolt. In fig. 92 the lower valves are the discharge and the upper the suction. The latter draw their air from a passage in the engine foundation, which communicates with the outer air ;

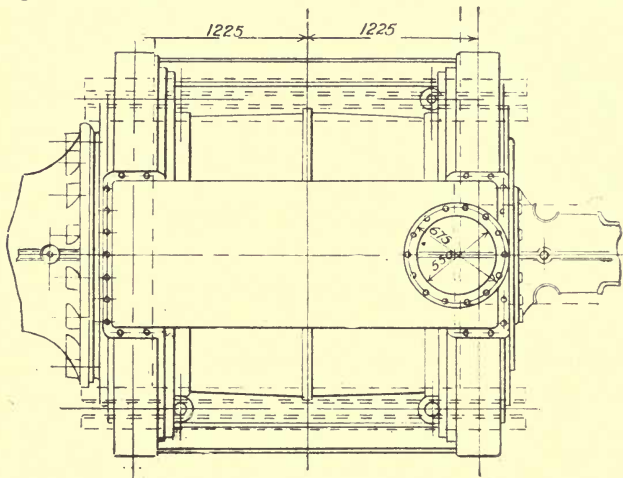

FIG. 90.

such passages usually terminate in a chimney, so that the air supplied to the cylinder is as cold and free from dust as possible. The ring-shaped discharge passages terminate in two rectangular openings 1,000 mm. by 240 mm. (39.4 in. by 9.45 in.), which are connected by a bent pipe of rectangular section to the discharge pipe of 550 mm. (21.7 in.) diameter, figs. 88 and 89. Fig. 91 gives an end view in the right hand upper quadrant ; a section through the cylinder passages in the left hand upper quadrant ; beneath this a view of the valve chest from the suction side ; and in the remaining quadrant a section through the discharge passage. The

steam valves are piston valves of 410 mm. and 800 mm. diameter (16.5 in. and 31.5 in.), with valve rods of 70 mm. and 100 mm. diameter (2.76 in. and 3.94 in.); the former has a variable cut off. There are three guide blocks to each piston rod: one on the tail rod of the blowing cylinder, the second between the two cylinders, and the third at the crosshead. The piston rods are 250 mm. diameter (9.84 in.),

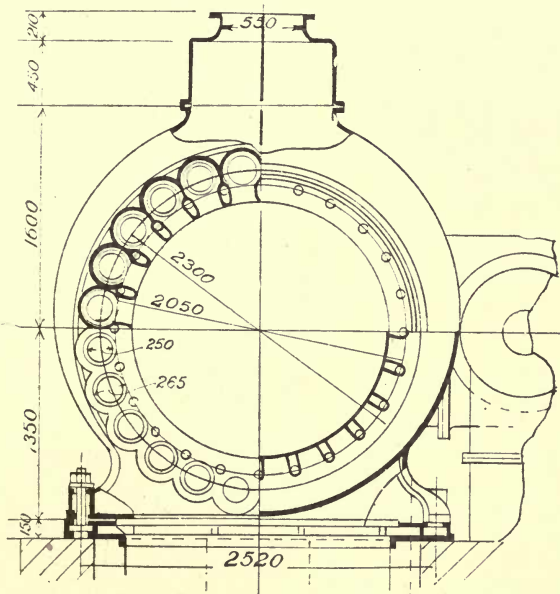

FIG. 91.

and the connecting rods have diameters of 220 mm. and 270 mm. (8.65 in. and 10.6 in.) at small and large ends, and their length is 4,250 mm. ( $167\frac{1}{2}$  in.) The distance between the centres of cylinders is 5,400 mm. (212.5 in.). The crank pin diameter and length are 400 mm. (15.75 in.), those of the crank journals 600 mm. and 750 mm. (23.6 in. and 29.5 in.), and the diameter of the crank shaft at the flywheel is 700 mm. (27.6 in.). The diameter of the flywheel

is 8,000 mm. (315 in.), the breadth of its rim 340 mm. (13.4 in.), and radial depth 435 mm. (17.1 in.); there are eight arms.

30. *Vertical Compound Bessemer Blowing Engine, constructed by Messrs. Schneider and Co., Creusot, for the*

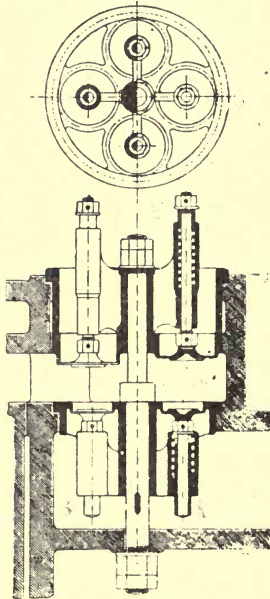

FIG. 92.

*Société des Aciéries de Longwy.*\*—This engine has the following leading dimensions:—

Diameter of high-pressure cylinder.	1,200 mm. (47½ in.)
Diameter of low-pressure cylinder.	1,700 mm. (67 in.)
Diameter of each blowing cylinder.	1,400 mm. (55.1 in.)
Stroke .....	1,400 mm. (55.1 in.)
Capacity per minute.....	400 c. m. (14,100 c. ft.)
Pressure above the atmosphere ...	29.4 lb. per sq. in.
Initial pressure upon the piston ...	78 lb. per sq. in.
Revolutions per minute .....	50.

\* "Appareils de Compression d'Air," from the Bulletin de la Société de l'Industrie Minière, Tome VII.

The indicated horse power was estimated at 1,400, and the consumption of steam at 14.3 lb. per indicated horse power

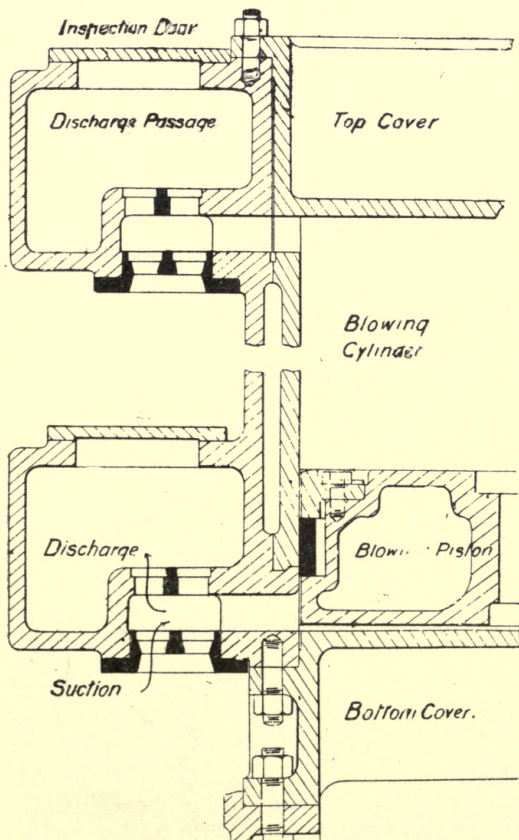

FIG. 93.

hour. There are two cranks at right angles; the blowing cylinders are placed above the steam; the steam valves are of the Corliss type, the steam valves having trip gear for the

high-pressure cylinder, but not for the low, in which the point of cut-off is fixed. The governor is so constructed that the speed can be varied as required. Fig. 93 shows a sectional elevation through the piston, liner, cylinder, and valve

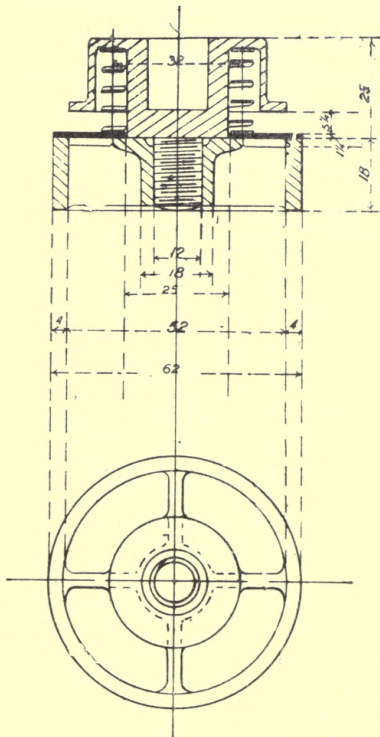

FIG. 94.

chest of the blowing cylinder, the valves not being shown in place. The blowing piston is at the bottom of the stroke. The cylinder is water jacketed. The air valves are self-acting, and are in sufficient number to reduce the velocity of the air through them to 82 ft. a second at 50 revolutions.



This type of valve is used by Messrs. Schneider and Co. for all powers and pressures, and works very well. Fig. 94 shows a sectional elevation and plan of the valve complete. The valve itself is a copper plate 62 mm. (2.44 in.) external diameter and 25 mm. (1 in.) internal, and  $1\frac{1}{4}$  mm. (.05 in.) thick. The spring is also of copper, and the valve seat and valve guard of bronze. The spring is compressed to 20.75 mm. (.817 in.) when the valve is closed. The guard permits the valve to rise 5 mm. (.195 in.), and the cylindrical area at the outer circumference of the valve is therefore 9.7 sq. cm., or  $1\frac{1}{2}$  sq. in. Messrs. Schneider give the area as 8.9 sq. cm., corresponding to a rise of 4.6 mm. (.18 in.). Just under the valve plate the passage has internal diameters of 54 mm. and 32 mm. (2.1 in. and 1.25 in.), and there are four ribs  $3\frac{1}{2}$  mm. (.136 in.) thick, which make the area of the passage 13.3 sq. cm., or 2.06 sq. in. The engine can work condensing or non-condensing, valves being fitted for that purpose in the exhaust pipes. The condensers and air pumps are in a pit at the back of the engine, fig. 95, in order that the jet may be drawn in by the vacuum alone. There are two vertical single-acting air pumps, driven by levers actuated by the crossheads of the piston rods. One pump is sufficient even at full speed.

---

## CHAPTER V.

### AIR COMPRESSORS.

31. These may be divided into single acting and double acting, or those that deliver dry air, have water injected into their cylinders, or a mass of water in the cylinder moving to and fro with the piston. But as the valves are the most important feature of the compressing cylinder, the best division is into those which have self-acting or mechanically-controlled valves. The former have the advantage of simplicity, and their first cost is consequently less; the latter are more durable, give less trouble, and allow a higher piston speed than the former. Self-acting valves are

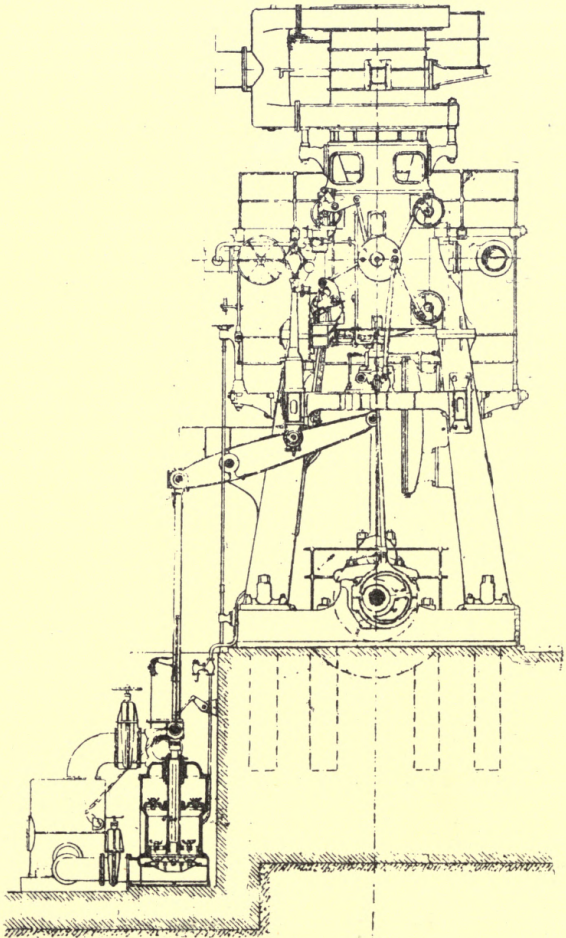

FIG. 95.

usually closed by difference of pressure and a spring, and opened by difference of pressure opposed by the spring; mechanically-controlled valves are opened by difference of pressure, and usually have a dashpot to prevent shock in opening, but mechanical means are used to bring them close to their seats shortly before it is necessary for them to close, which they do by difference of pressure at the right moment without shock. They can therefore be made large, and given a considerable lift.

Reciprocating or oscillating valves, the latter, for example, of the Corliss type, may be used as in blowing engines for the admission of air, because they close at the end of the stroke; and the moment of admission, *i.e.*, when the compressed air in the clearance has expanded to atmospheric pressure, can be approximately determined. They may also be used for the discharge valve, closing at the end of the stroke, but as the point when discharge commences depends on the ratio of compression, they must either be opened by mechanical means depending on difference of pressure, or there must be an additional discharge valve which prevents the return of air from the pressure pipes into the cylinder.

32. *Suction and delivery valves for a compressor constructed by the Friedrich Wilhelms-Hütte, of Mulheim, a.d. Ruhr.*—There are two air and two steam cylinders, the diameter of the former being 625 mm. (24.6 in.), and of the latter 700 mm. (27.6 in.), with a stroke of 1,000 mm. (39.4 in.). The air compressing pistons are driven direct from the steam pistons, the crank shaft and flywheel being on the other side of the steam cylinders; the cranks are at right angles. There are three delivery, and five suction valves in each cylinder end, which is divided into two halves by a vertical diameter, the delivery valves being placed on one side of this, and the suction on the other. A delivery valve is shown in sectional elevation in fig. 96, and in end view in fig. 97. The passage in the valve seat is 90 mm. (3.55 in.) diameter, so that the discharge area is 0.062 of the piston area. The seat is of bronze, and the conical valve of 100 mm. (3.94 in.) diameter, of delta metal. It has a hollow guide spindle of 43 mm. (1.69 in.) diameter,

FIG. 96.

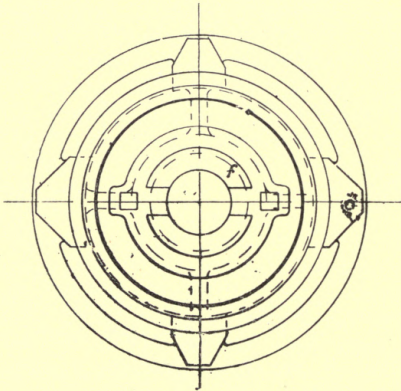
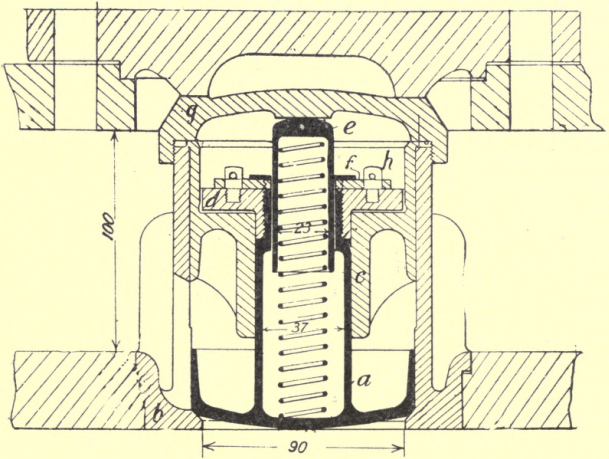

FIG. 97.

in which is a spiral spring of steel of 22 mm. external diameter ( $\cdot 867$  in.), and 2 mm. diameter wire. The guide

FIG. 98.

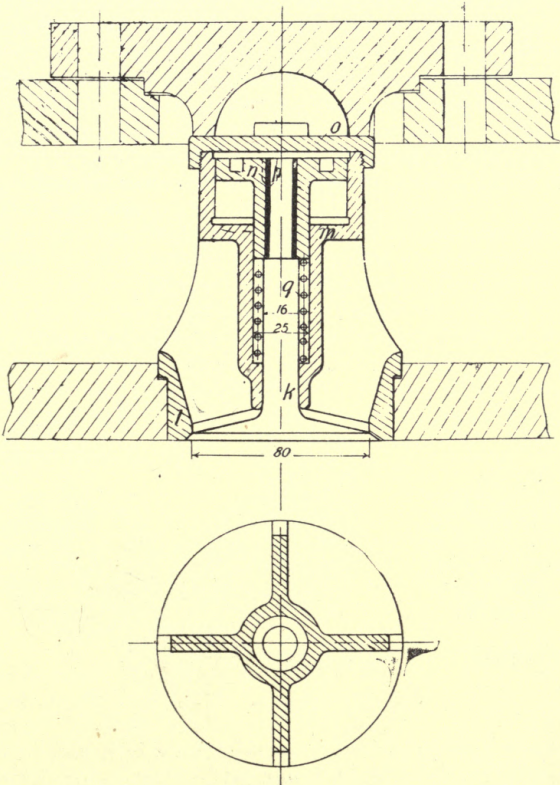

FIG. 99.

spindle carries a piston of delta metal at its outer end, which works in a dashpot. The piston is 91 mm. diameter ( $3\cdot 59$  in.), and the cylinder in which it works 92 mm.

(3.62 in.), so that the air can pass round its circumference. The spring is held at its outer half in a bronze cylinder of 28 mm. (1.1 in.) diameter, the inner diameter of the valve guide being 28½ mm. The dashpot, of course, prevents shock, with consequent noise and damage to the valve when the valve is opening and closing. Fig. 97 is an end view with the dashpot cover removed. Fig. 98 is the suction valve, which is of delta metal, the seat being of gun metal, the diameter being 80 mm., so that the suction area is 0.082 of the section of the cylinder. The valve spindle is 16 mm. (.63 in.) diameter, and a piston is screwed upon its outer end, working in a dashpot. The diameter of piston and dashpot is 60 mm. (2.36 in.) diameter, and the valve is pressed on its seat by a spring of steel 24 mm. external diameter (.945 in.) of 3 mm. wire. Fig. 99 is a sectional end view through the middle of the spindle.

33. *Compressor constructed by the Tilghman's Patent Sand Blast Company.*—Sections through the cylinder are shown in figs. 102 and 103, and the construction of the valves is illustrated in figs. 100, 101, the former showing the parts of the inlet valve, and the latter those of the delivery. As the inlet valves are practically inside the cylinder, the

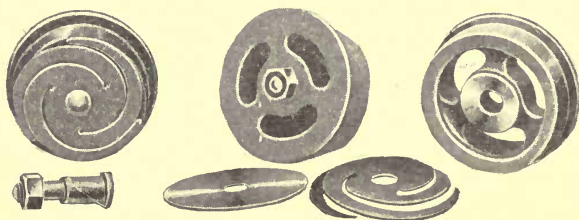

FIG. 100.

clearance space required to admit them to a great extent determines the ultimate volumetric efficiency of the compressor. Matthewson's patent valves occupy very small space in proportion to their areas, and the clearance is only 1 to 2 per cent of the cylinder capacity. They are exceedingly light (a 3 in. valve and spring scaling less than two ounces), perfectly air-tight, and practically noiseless in

working. Both valve and spring are made from a special quality of sheet steel, the valve being ground on the contact side whilst held by a magnetic chuck. The delivery valve is a light steel stamping held on its seat by a special close coil spring, which, when the valve has attained the required lift, is completely closed, thus avoiding the shock caused by a fixed stop. The efficiency of this design is amply proved by their long life and by the absence of noise when working. The cylinders are fitted with cast-iron liners of a special mixture, the space between liner and shell forming the water jacket. The cylinder ends are perfectly flush, and as guards are fitted to the inlet valves, nothing can possibly find its way into the cylinder.

The air openings through these guards have sufficient area to allow the gas to pass freely through them. Regarding water jacketing, it is claimed that greater efficiency is obtained by utilising the cylinder ends as valve chests than by using radial valves and water jacketing the cylinder ends, as the

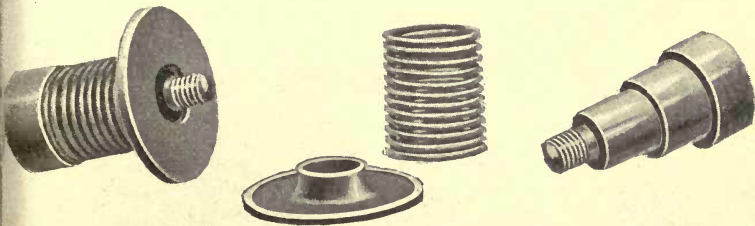

FIG. 101.

increased valve area and reduced clearance more than compensate for any extra cooling obtained. When it is considered that with compressors ranging from 20 to 1,000 cubic feet of free air per minute a single stroke only occupies  $\frac{1}{10}$ th to  $\frac{1}{5}$ th of a second, it cannot be expected that much cooling will take place in the cylinder. Volumetric efficiencies of 90 and 80 per cent are guaranteed with compound and single-stage compressors respectively, working up to a pressure of 100 lb. for the former and 80 lb. for the latter. A patent governing inlet valve is fitted, which automatically

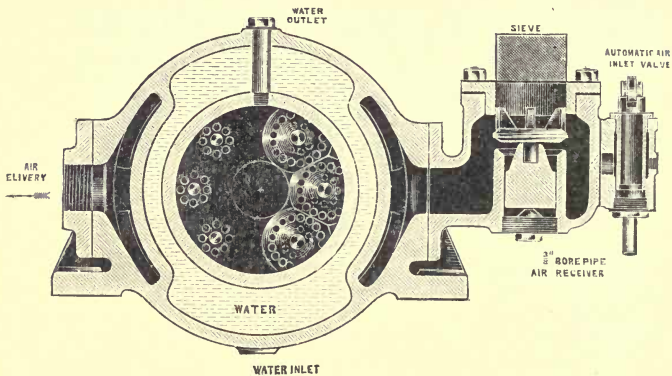

FIG. 102.

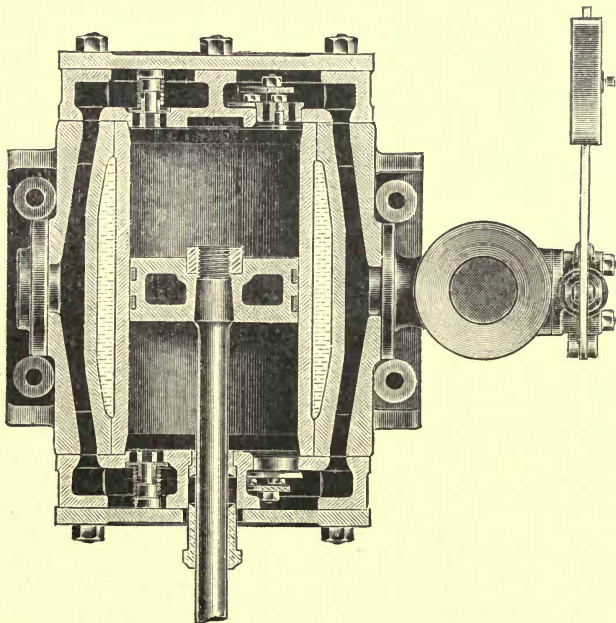

FIG 103.



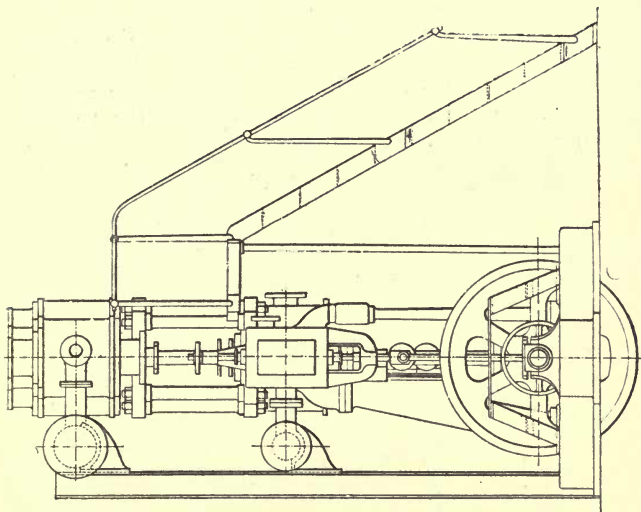

FIG. 105.

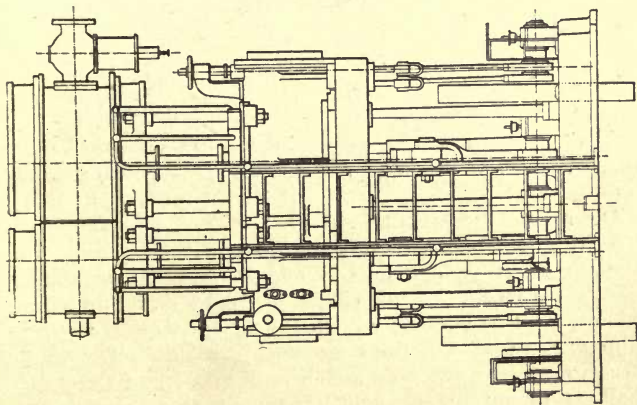

FIG. 104.

regulates the amount of air compressed to that required (see figs. 102 and 103). When the amount of air required is less than the capacity of the compressor the air pressure rises, and, by means of a small weighted piston, air is admitted from the air receiver to the regulator cylinder, thus closing the air inlet, and thereby putting the piston or pistons into equilibrium by causing a partial vacuum on

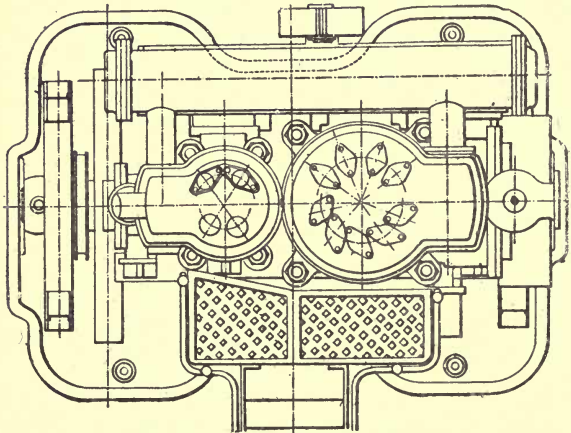

FIG. 106.

both sides. The power saved by its use is considerable where there are frequent variations in the amount of air used.

34. *Vertical Compound Air Compressor, constructed by Messrs. Duncan, Stewart, and Company, Glasgow.*—The machine has steam cylinders 12 and 24 in. diameter, and air cylinders 13 and 22, the stroke being 12 in. The steam cylinders are supported at the back by strong cast-iron columns, and at the front by steel columns. The whole structure is mounted on a bedplate of cast iron; the crank shaft is of mild steel, with cranks at right angles and webs forged solid. Both steam cylinders are fitted with Meyer's valve gear. Each piston rod is in one forging.

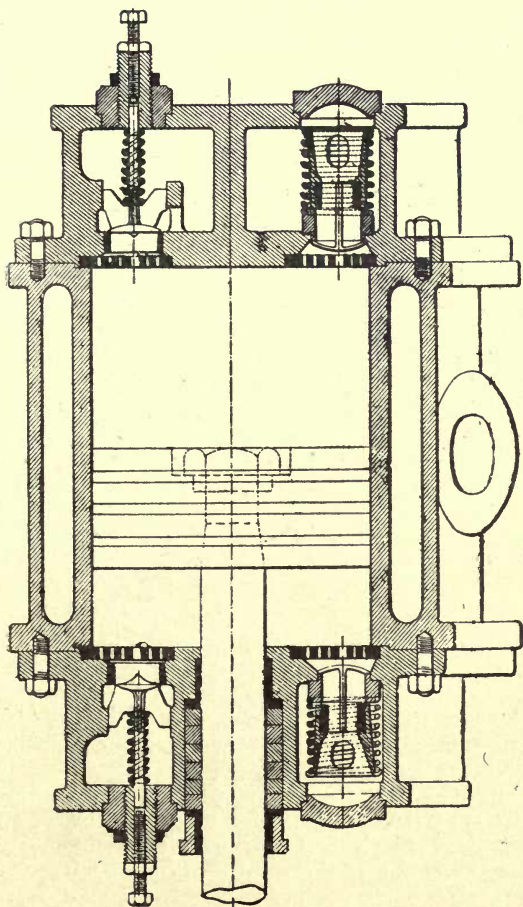

FIG. 107.

Three views of the engine, for which we are indebted to Messrs. Duncan, Stewart, and Co., are shown in figs. 104, 105, and 106, and fig. 107 is a section of the high-pressure air-cylinder, from which it may be seen that the valves are placed in the covers at top and bottom. The moving parts of the valves are of manganese bronze, and are held in position by springs whose tension is adjustable. The valve seats and guards are of best phosphor bronze, and grids are placed above and below the valves in the lower and upper covers to prevent their falling or being drawn into the cylinder. Each cylinder is surrounded by a water jacket, and there is also a tubular cooler between the cylinders, fig. 106. The air inlet valve on the low-pressure cylinder has an automatic adjustment for controlling the volume of air passing according to the amount required. The steam pressure is 120 lb., and the air 100 lb. When running at 100 revolutions, the capacity is 400 cubic feet per minute.

35. *The Kryszat Air Compressor.*—Messrs. Schäffer and Budenberg have kindly sent us a description of this compressor, which is shown in fig. 108, a section of the cylinder being given in 109. In this system the suction and pressure valves are compactly arranged one within the other, and they form the actual cylinder end. Both valves are of the same diameter as the piston itself, their lift is very small, and there is no clearance whatever between piston and valves. It can be run at a high speed, and there is no loss through clearance space. Water cooling can in many cases be dispensed with, as the valves offer a large cooling surface for the compressed air. There are no stuffing-boxes nor crosshead.

In fig. 109, *a* is the suction valve, and *b* the pressure or delivery valve, which latter is carried by a metallic diaphragm *g*, which is firmly held at the joint ring *c*; *f* shows the spring of the suction valve. The seat of the suction valve is on the pressure valve, and *d* represents the seat of the pressure valve against the end of the cylinder.

The movement of the pressure valve and diaphragm is checked by the spring *h*, and the tension of this spring can

be regulated by the nut *f*. The air is drawn in by the central passage, and is discharged by the pipe indicated by the arrow pointing upwards. The pressure space is

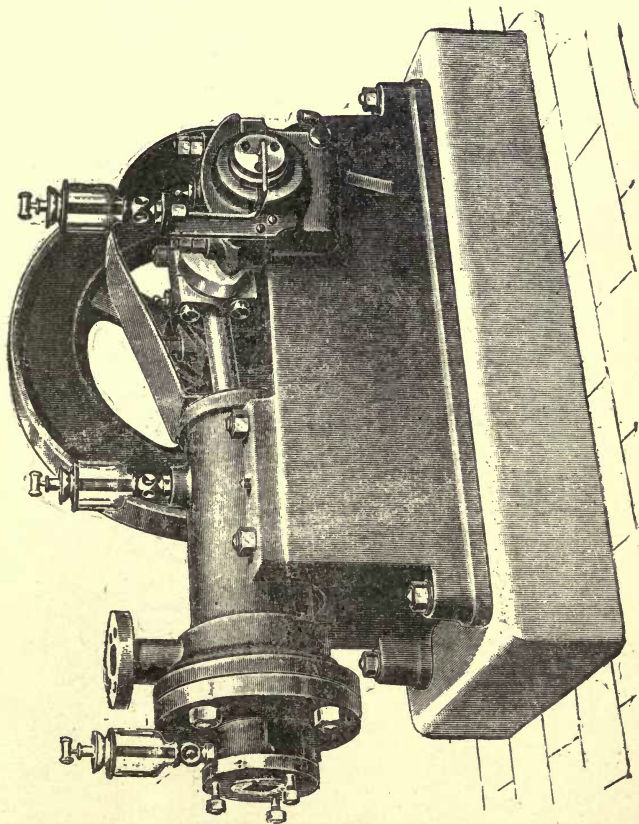
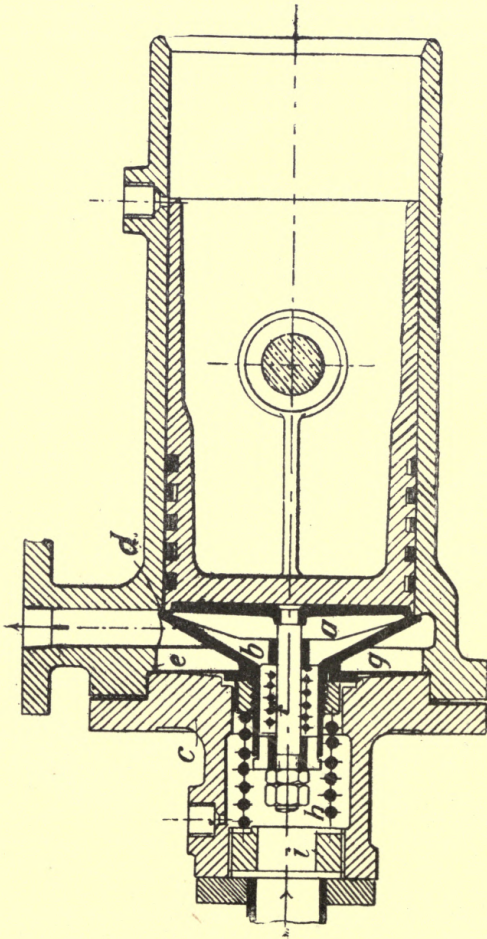

FIG. 108.

separated from the suction by the pressure valve *b* and the diaphragm *g*.

It will thus be seen that the valves close tightly upon the cylinder end, and will open readily when the required



F.G. 109

pressures are obtained. The piston may actually touch the surface of the suction valve, thereby raising the pressure valve from its seat. When the piston commences the

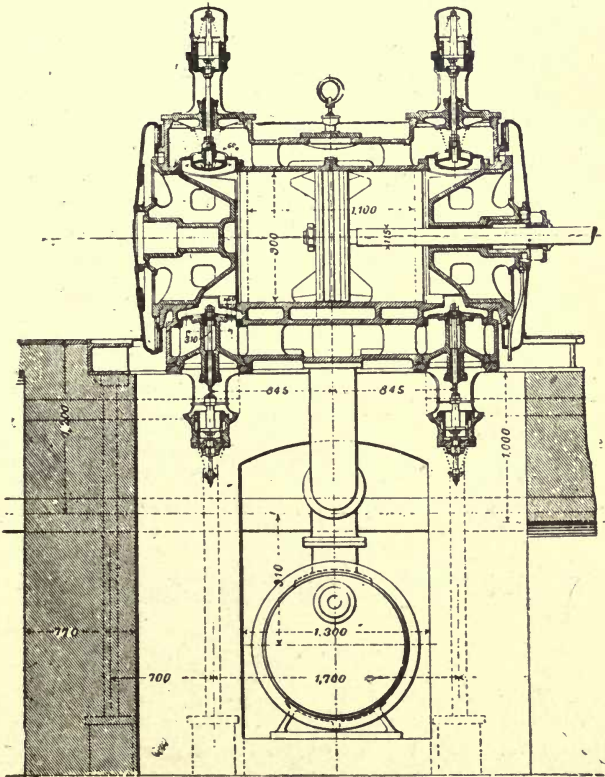

FIG. 110

return stroke the pressure valve closes, and the air is drawn in at once.

The flywheel is arranged to form the driving pulley. The cylinder and bearings are lubricated by ordinary drop

sight-feed lubricators. Ring lubrication is employed in the main bearings of the crank shaft. When required for pressures not exceeding 120 lb. per square inch, water cooling can be dispensed with, provided the compressor is required to work for short periods only at frequent intervals, and not continuously. For continuous working it is preferable to employ water cooling, even at lower pressures.

These compressors can be used for gases as well as air. They have hitherto been made in two sizes, with 4 in. and 6 in. diameters of piston respectively, but larger sizes can be supplied if required. The stroke of each size is 4 in., and their capacities in cubic feet per hour 525 and 1,050.

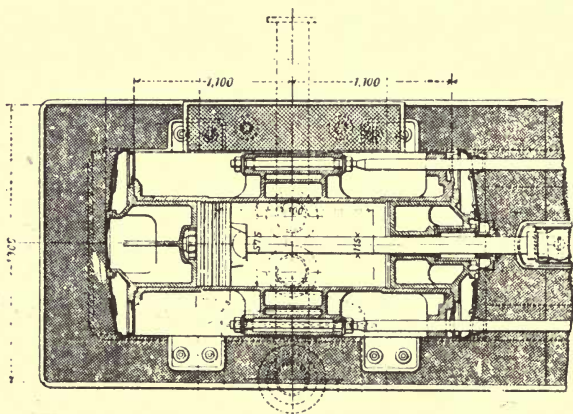

FIG. 111.

36. *Compound Air Compressor, constructed by Messrs. Schüchtermann and Kremer, Dortmund, for the Harpener Mining Co.\**—Figs. 110 to 115 show the air cylinders and valves. Fig. 110 is a sectional elevation of the low-pressure cylinder, and fig. 111 a sectional plan view of the high-pressure, while figs. 112 and 113 show transverse sections of both. The engine is cross-compound, the high-pressure air piston being driven direct from the high-pressure steam

\* *Engineering*, December 12, 1902.



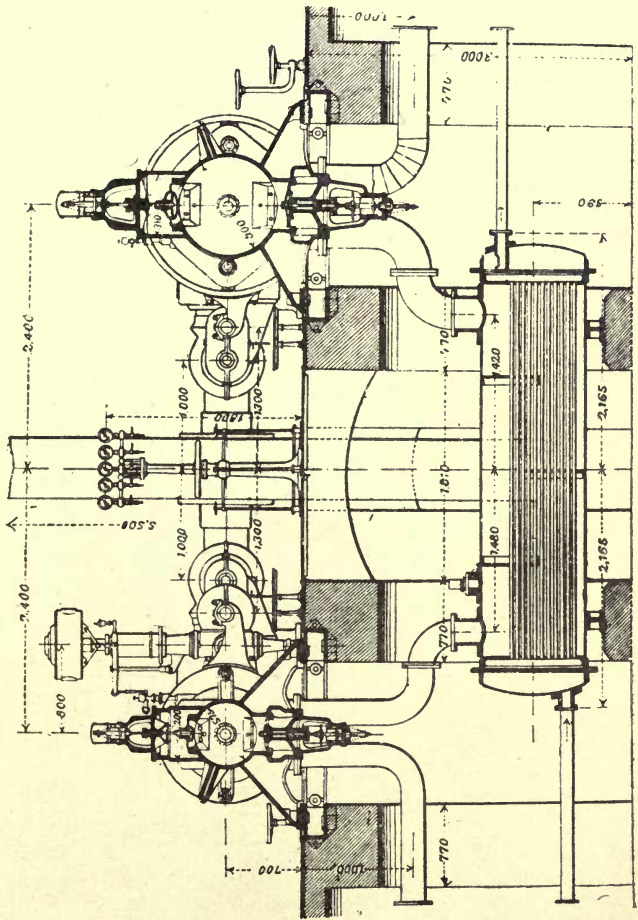

FIG. 112.

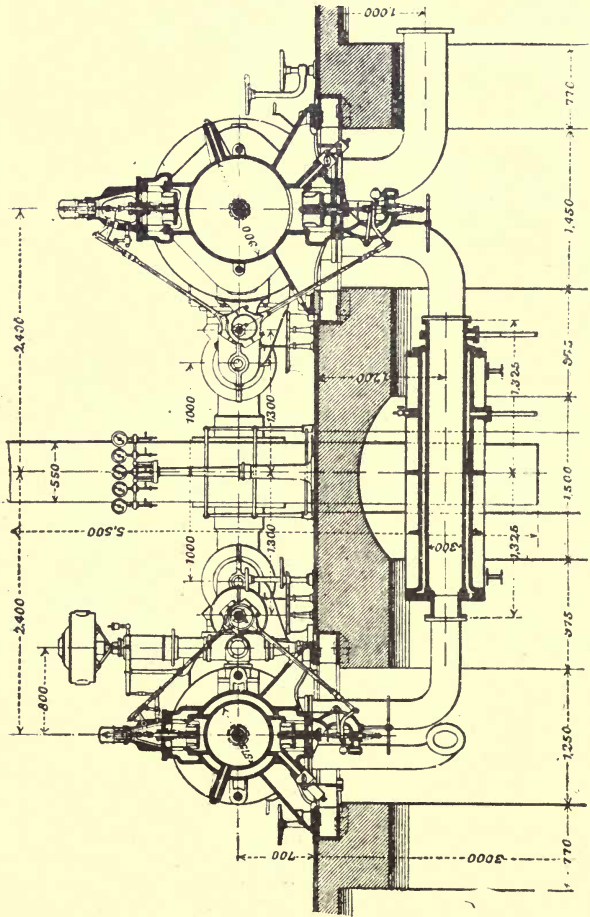

FIG. 113.

piston, and similarly for the low-pressure. It is calculated to compress 5,200 cubic metres (183,650 cubic feet) of air per hour. The leading dimensions are :—

Diameter of low-pressure steam and air cylinders .....	900 mm. (35·43 in.)
Diameter of high-pressure steam and air cylinders .....	575 mm. (22·63 in.)
Stroke .....	1,100 mm. (43·30 in.)
Flywheel, diameter .....	5,500 mm. (216·5 in.)

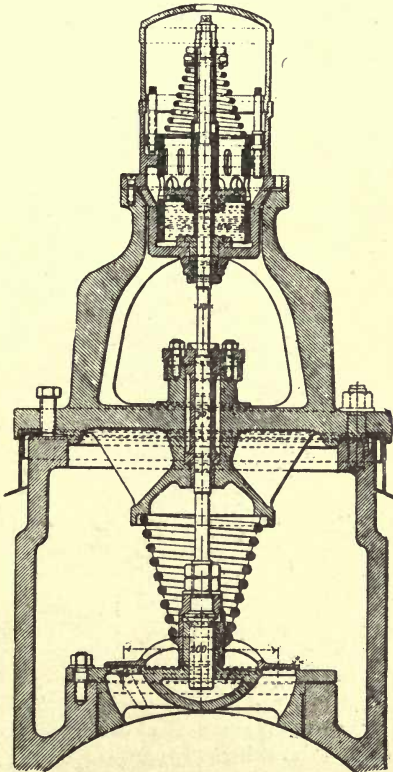

FIG. 114.

The steam pressure is 169 lb. per square inch, the air pressure 88 to 117 lb. per square inch. There is a tubular inter cooler (fig. 112), but the air cylinders are not fitted with

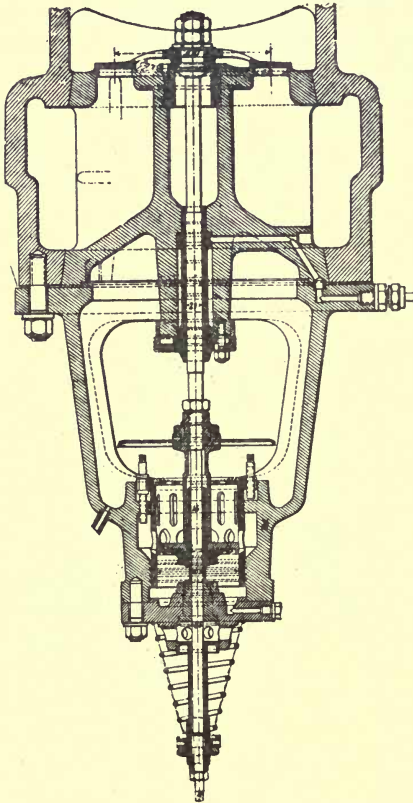

FIG. 115.

cold water jackets, nor are they otherwise cooled. The high-pressure steam cylinder and the intermediate re-heater underneath the floor level (fig. 113) are steam-jacketed. The

suction and delivery air valves are self-acting, of the Collmann type, and are made of aluminium bronze. Fig. 114 is a delivery and fig. 115 a suction valve. In this type a spiral spring closes the valve, an oil piston coming into play at the last moment to prevent the valve from striking on its seat, the working being noiseless throughout. The action of the oil piston can be regulated while the engine is in motion; both the valves are easy of access for maintenance and repair. The piston is immersed in oil, which almost reaches the upper part of its neck-shaped extension. This remains uncovered for regulating purposes. The oil flows from one side of the piston to the other through grooved ports cut in the wall of the bush in which the piston works, and these, according to the position of the piston in the bush afford a larger or smaller area open to the flow of the oil. Just before the valve touches its seat its downward motion is retarded by the piston, which has reached a point of its stroke at which the space open to the flow of the oil is very small. This ensures the noiseless closing of the valve. The above action can be easily adjusted by altering the position of the piston relative to the ports, either by moving the piston or the bush, the latter being the easier. The oil piston contains a relief valve, which aids the flow on the upward stroke.

37. *Ingersoll Sergeant Compressors*.—Fig. 116 is a longitudinal section through the cylinder of a type of compressor constructed by the above company. The valves are of forged steel with a vertical lift, the delivery valves having springs within them, those on the suction valves being placed round the valve spindles and pressing upon collars pinned to their lower ends. The suction valves being at the bottom of the cylinder, there is no fear of their being drawn into it and so wrecking the compressor, so that sieve-like guards, which take up a considerable amount of heat and warm the incoming air, are unnecessary. The piston, as it nears the end of the stroke, forces oil upon the suction valves. The covers and sides are water-jacketed, but the valves are accessible by removing the caps above and below them. The compressing piston is driven direct from the steam piston, fig. 117, a crosshead on the piston

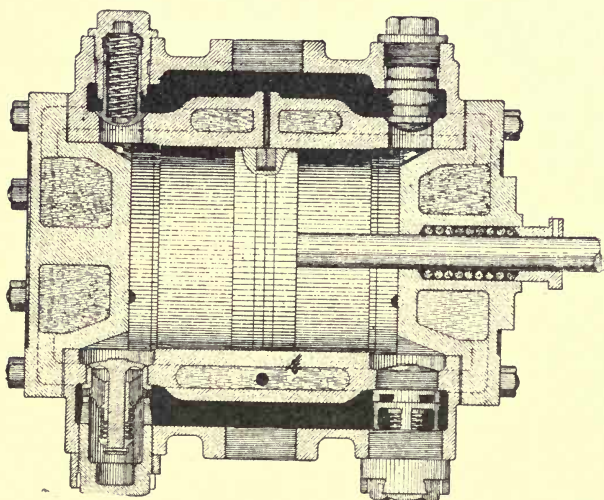

FIG. 116.

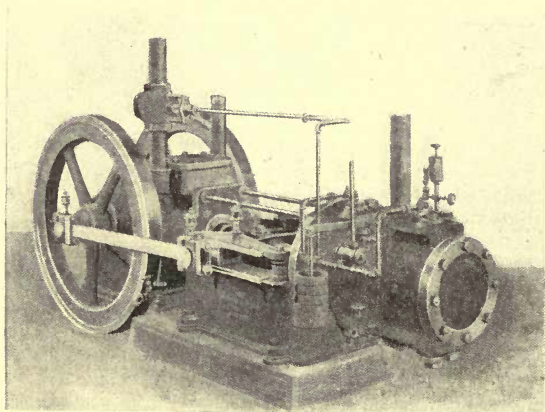

FIG. 117.

rod working in guides on either side, having at its ends two connecting rods which drive overhung cranks keyed on a shaft with two flywheels on either side of the steam cylinder, so that the arrangement is very compact. This type is made in twelve sizes for pressures from 15 lb. to 80 lb., the smallest size having steam and air cylinders 6 in. diameter with 6 in. stroke, and the largest with 12 in. diameter and 12 in. stroke for 80 lb. pressure, but with an air cylinder diameter of  $16\frac{1}{4}$  in. for 30 lb. pressure.

FIG. 119.

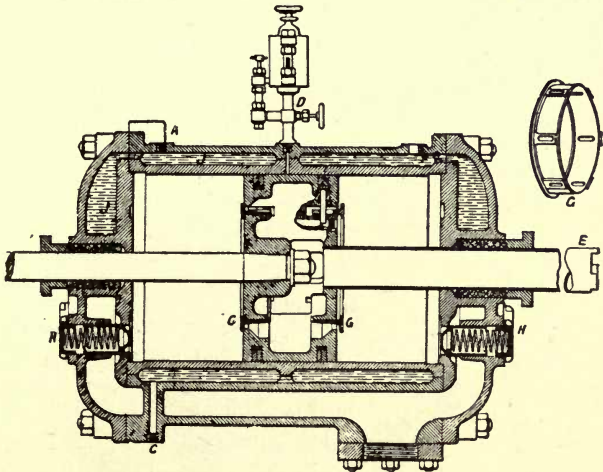

FIG. 118.

Another very successful form of compressor is shown in sectional elevation in fig. 118, in which the suction valves are carried by the piston, which is hollow; the piston rod at the end furthest from the steam cylinder being hollow and forming part of the suction pipe, to which it is connected by a stuffing box. The admission of air being through a single tube, a constant flow of air is created in one direction, thus completely filling the cylinder at each stroke with air at atmospheric pressure, owing to its momentum. The air inlet valves are large rings G, of very soft homogeneous open-

hearth steel, made from a solid billet, which is punched and worked into the required form and size without any welding. So well do they wear, that the company guarantee them for five years, and state that they have not had a single case of breakage of one of these valves, one of which is also shown in fig. 119. The holes in its sides are for pins, which are fixed in the piston, and prevent rotation without hindering the opening and closing of the valve. The inertia of the valve at the end of the stroke assists its rapid opening and closing at the right moment. The covers and side of the cylinder are water-jacketed, and the delivery valves placed in the covers. The piston is driven from the tail rod of the steam piston, the flywheel shaft being on the further side of the steam cylinder.

Amongst several other types, this firm constructs compound compressors, compressing to 100 lb. The diameters of the smallest in the order—steam high-pressure cylinder, steam low-pressure cylinder, air low-pressure cylinder, air high-pressure cylinder—are  $10\frac{1}{2}$  in., 18 in.,  $16\frac{1}{4}$  in., and  $10\frac{1}{4}$  in., with a stroke of 30 in. This runs at 90 revolutions, has a capacity of 6.84 cubic feet of free air per revolution, and requires 97 I.H.P. to drive it. The largest size has diameters 24 in., 44 in.,  $36\frac{1}{4}$  in., and  $22\frac{1}{4}$  in.; stroke 48 in., 70 revolutions, 55 cubic feet, and 664 I.H.P. The total efficiency of this latter, assuming a 100 per cent volumetric efficiency, is, from equation (7),

$$\begin{aligned} \eta_1 &= \frac{\text{ideal horse power}}{\text{indicated horse power}} \\ &= \frac{144 \times 14.7 \times 55 \times 70 \times 2.3 \log. 7.82}{33000 \times 664} \\ &= 76.4 \text{ per cent.} \end{aligned}$$

With a volumetric efficiency of 95 per cent this would become 72.5, in any case a good result.

38. *Air Compressor Valves, by Davey, Paxman, and Co., Colchester.*—Figs. 120, 121, 122 show the suction, and figs. 123, 124, 125, and 126 the delivery valve constructed by this firm for a cylinder  $24\frac{1}{2}$  in. diameter and 32 in. stroke. Fig. 120 is a longitudinal section, and at the top a half plan,



of the valve. It will be seen that this is treble-beat, the outer diameters of the three seats being  $6\frac{1}{4}$  in.,  $4\frac{1}{4}$  in., and 2 in. The valve is of high carbon steel, and contains eight passages through which the air that passes the two inner seats can flow. The valve has a long spindle, which is

FIG. 121.

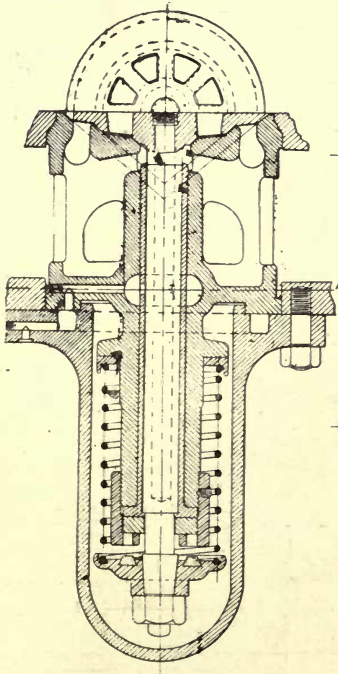
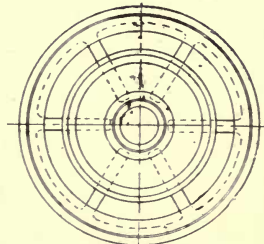
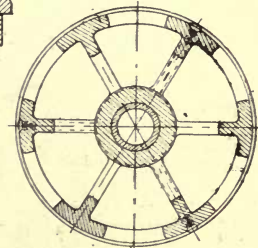

FIG. 120.



PLAN OF VALVE SEAT



SECTION THRO' VALVE SEAT AT A.A.

FIG. 122.

guided in a bush of gun metal. Fastened to the end of the spindle is a cap, against which a spiral spring presses, the lift of the valve being fixed by a ring of hardened steel, of dovetail section, held by the cap. When the valves work horizontally the centre of gravity always remains inside the

guide bush whether the valve is open or shut, so that the valves never drop when they are open, and are bound to close fair and true. Fig. 121 is a plan of the valve seat, and fig. 122 a sectional plan cutting it at about the middle of its

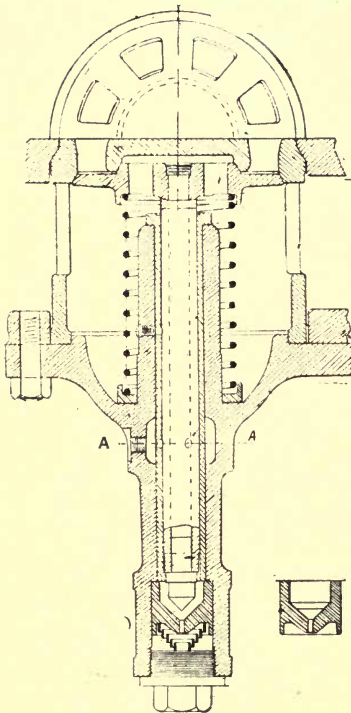

FIG. 123.

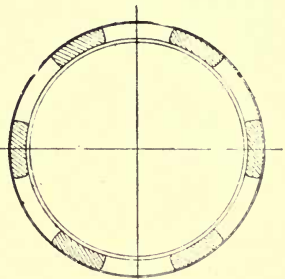

FIG. 124.

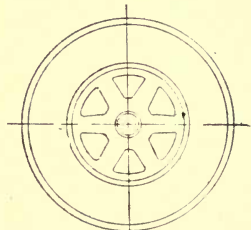
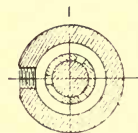

FIG. 125.—Plan of Valve Face.



SECTION AT A A

FIG. 126.

height. The seat is constructed of cast iron. The delivery valve is shown in longitudinal section in fig. 123. It has two beats, whose external diameters are  $6\frac{3}{8}$  in. and  $3\frac{3}{4}$  in.,

and it contains eight passages through which the air that passes the inner seat flows. The valve is kept to its seat

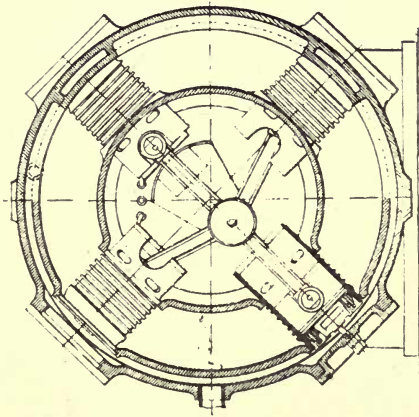

FIG. 128.

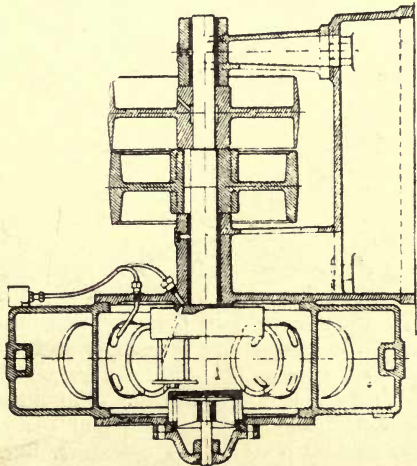

FIG. 127.

by a spiral spring, and the valve spindle is guided by a bush. When the valve opens a point at the end of the

spindle comes against a small piston of steel, which is acted upon by a conical spiral spring. The lift is thus limited, without shock. Fig. 124 shows a section of the valve seat, and fig. 125 a plan of the face, while fig. 126 is a transverse section through the middle of the valve spindle.

39. *The Reavell Air Compressor.\**—Figs. 127 and 128 show two sectional elevations of this four-cylinder compressor, which can be driven by steam belting or electro-motor. The casing is circular, and the cylinders are provided with trunk pistons, whose connecting rods are

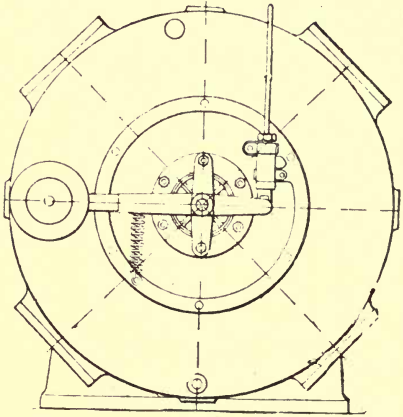
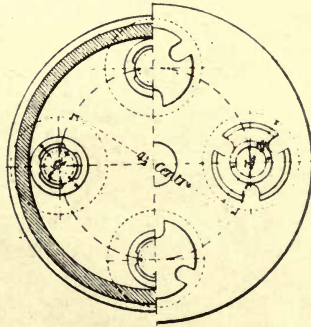
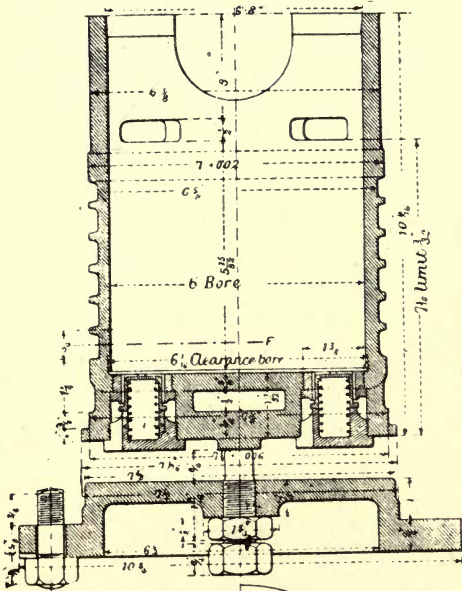

FIG 129.

actuated by a single crank. It will be seen, figs. 133 and 134, that the connecting rods have only a small bearing on the crank pin, and are held in place by two keeper rings. The gudgeon at the piston end is hollow, and has a groove cut in it, which serves as an admission passage when the piston is moving towards the centre. The piston is also shown in figs. 135 and 136, in plan and sectional plan. There are also suction ports in the cylinders, figs. 130 and 132, which are uncovered when the piston reaches the end

\* *Engineering*, February 16th, 1900.

FIG. 130.



SECTION THRO E F

FIG. 131.

FIG. 132.

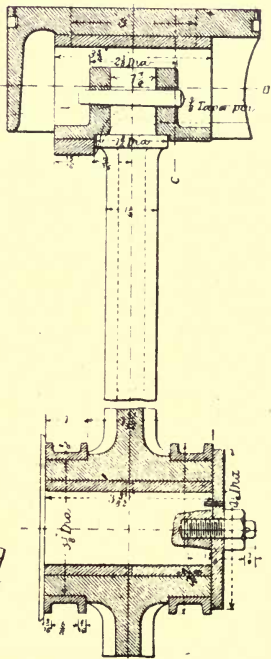
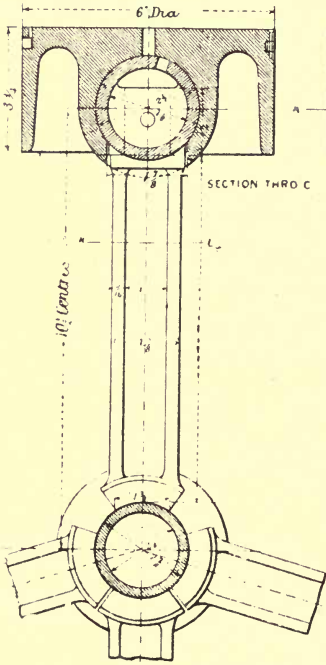
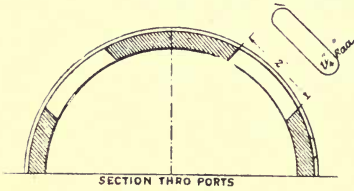

FIG. 133.

FIG. 134.

of the suction stroke. The air is drawn in to the centre of the casing through a valve placed at one side, which consists of a movable and fixed cylinder, the former moving inside the latter, having radial passages cut in it and being fixed to a lever, fig. 129, held down by a weight and a spring, but raised by a small plunger working in an air cylinder at the other end, which is supplied with air under pressure, so that if this pressure is in excess of that required the weight is raised and the passages cut in the cylindrical valve are closed. A vacuum is thus formed in the centre of the casing, and the work required to drive the compressor is very small. The cylinders are water-jacketed, and are corrugated to increase the cooling surface. They all deliver into a circular passage around the casing, fig. 128, and ready

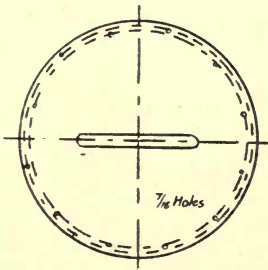

FIG. 135.

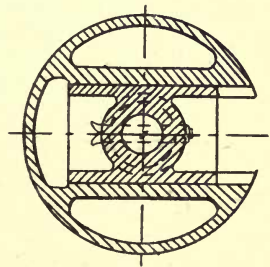

FIG. 136.

access to the delivery valves can be obtained through the covers. These valves are of steel and are very light. They will be shown later in detail in connection with this firm's four-cylinder compound compressor. They are kept in their places by light springs, fig. 130. The cylinder cover is hollow and connected with the water jacket.

40. *The Reavell Compound Air Compressor.*—This type of air compressor was formerly constructed by Messrs. Reavell and Co., of Ipswich. Their latest design is described on page 159. Fig. 137 shows a sectional elevation through the axis of the shaft, and fig. 139 one at right angles thereto. From the latter it will be seen that the crank drives four connecting rods, and these in turn four pairs of high and low

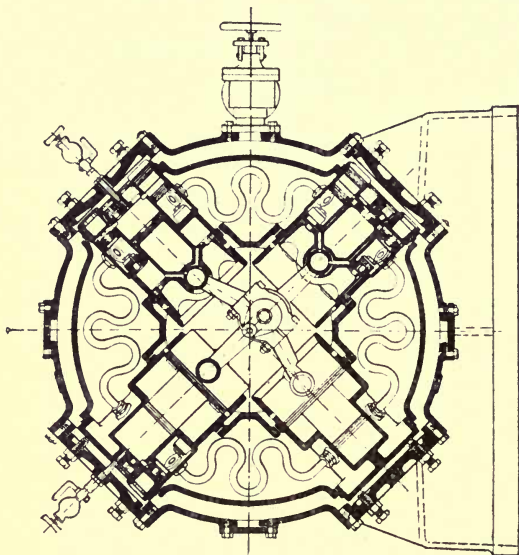

FIG. 138.

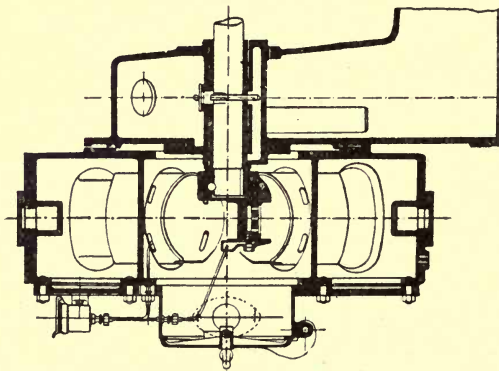

FIG. 137.



pressure guide pistons tandem fashion. The low-pressure cylinders have no suction valves, but each connecting rod has two milled out passages, which connect the cylinder with the space in which the shaft works during its inward or suction stroke, but on the return stroke are closed. There are also passages in the cylinder walls, which are opened just before the end of the stroke, thus ensuring the complete filling of the cylinder. On its outward or return stroke the air is compressed until it lifts the discharge valves, and the air passes into the receiver. All four receivers are connected

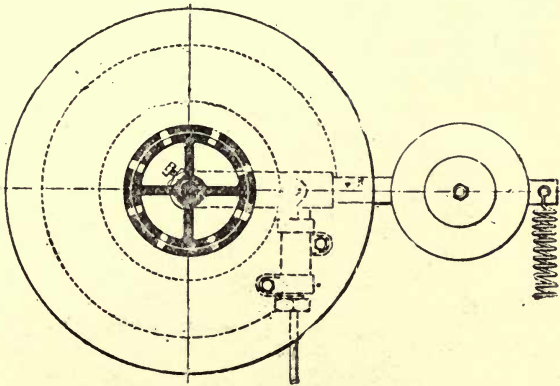

FIG. 139.

together by bent pipes, and as, while one low-pressure piston is compressing, the opposite high-pressure is drawing in a charge of air, the air has to travel from one side of the compressor to the other, and is thus cooled in the bent pipes, which are surrounded by water. The principal advantage of compound compression is, of course, that the air can be cooled in an intermediate receiver. When the small piston moves inwards air is drawn in through the suction valves at the side of the end of the cylinder, and on its outward stroke the air passes through the delivery valves in its end into a port cast round the periphery of the casing. Three sides of this port are in contact with the cooling water in the casing

or tank. The valves, one of which is shown in fig. 138, are of one size in all sizes of compressors, the number being governed by the requirements of each size of cylinder. Each valve weighs less than an ounce, the travel is only  $\frac{1}{16}$  in., and they work noiselessly. With a four-cylinder machine running at 250 revolutions, there are 1,000 deliveries of air per minute, or more than 16 per second. This continuous stream enables a large reservoir to be dispensed with. The diameters of the low and high pressure cylinders are 10 in.

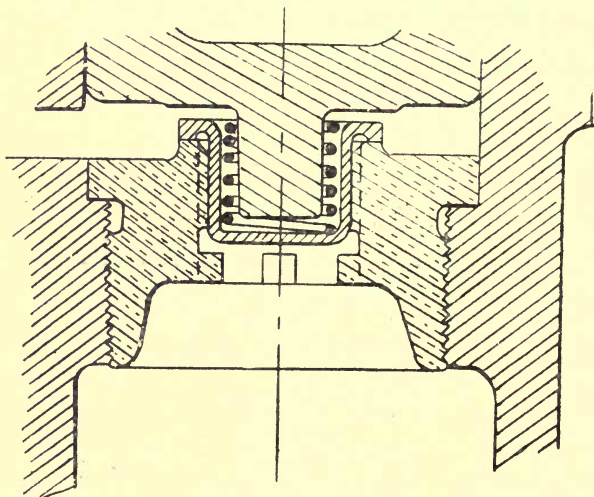

FIG. 140.

and 5 in. respectively, so that, as the larger piston is annular, the ratio of areas is 3 to 1. The stroke of the pistons is 5 in. The air is admitted to the centre of the casing through the openings at the end and through an automatic inlet arrangement, figs. 137 and 139, the former giving a vertical section through the central spindle and the latter one transverse thereto. The air supply is controlled by this, so that when no air is required from the compressor the inlet valve is automatically closed. Referring to fig. 139, it will be seen that the inlet valve consists of two concentric rings,

of which the inner is movable, while both have passages cut in them. The inner ring carries a spindle which has attached to it a weighted lever with a controlling spring. To the underside of the lever is fastened a small piston rod, whose piston works inside a cylinder, the underside of which is in connection with the air delivery pipe. When the

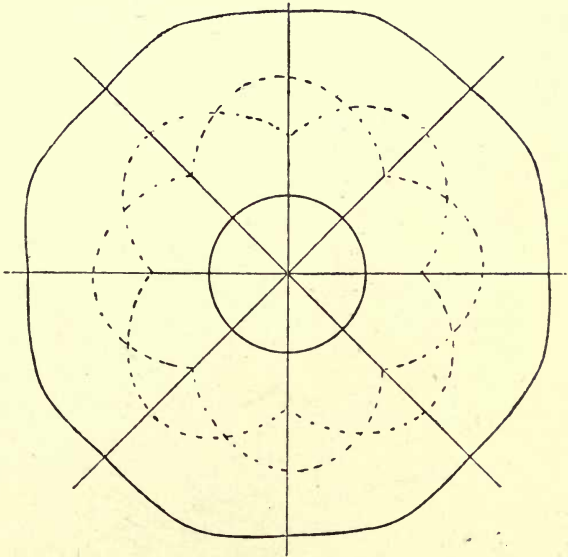

FIG. 141.

compressor is working normally the valve is in the position shown, so that the ports are open, but when the pressure exceeds a certain amount the piston raises the lever and closes the passages. Then, since a vacuum is soon formed in the suction chamber, the compressor requires very little work to drive it.

The type of valve fitted is shown in section in fig. 140. Each cylinder has a suitable number of these valves. These compressors can be driven singly, or one at each end of the engine or motor shaft. Fig. 141 is the diagram of torque

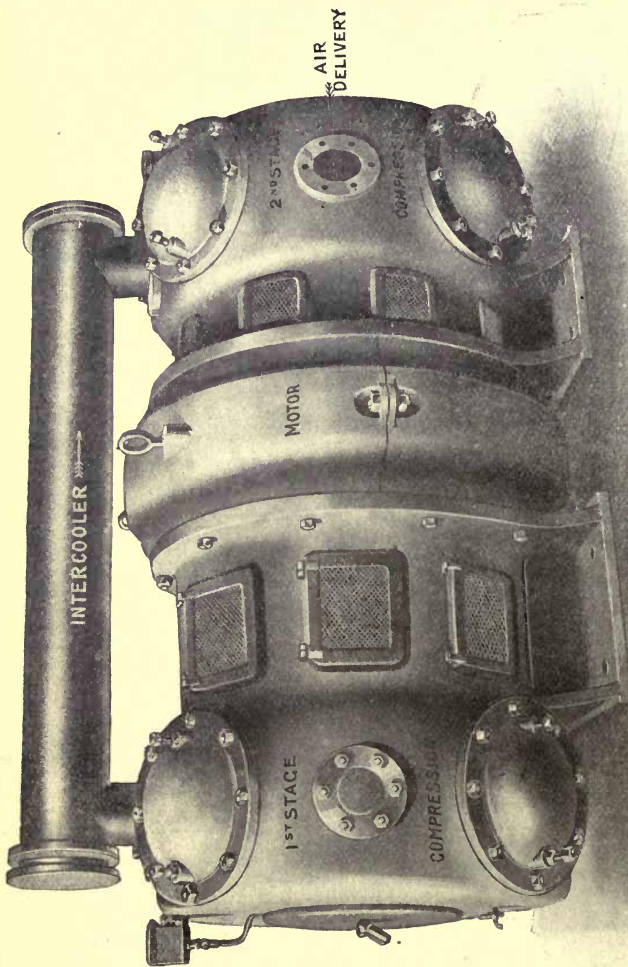

FIG. 142.

in the latter case, the dotted lines showing the torque required by each compressor, and the full line the sum of these, giving very nearly a uniform resisting moment.

41. *Reavell Two-stage Air Compressors.*—The latest design of these compressors, which is intended to supersede those already described, is shown in perspective in fig. 142. There is a motor in the centre, the low-pressure cylinder being on the left and the high-pressure on the right; between these is an inter-cooler. Each of these compressors is similar to the belt-driven single-stage compressor shown in section in figs. 143 and 144. In fig. 145 a sectional elevation is also shown of the arrangement of motor and compressor. A continuous shaft passes through the whole machine, with a crank at each end for the compressor, and on this shaft is mounted either the armature of a continuous-current motor or the rotor of an alternating-current machine. Single-ended compressors are also constructed by this firm on the same lines as illustrated in fig. 146, who also build single and double ended portable compressors, one of the latter being shown in fig. 147. These compressors have no suction valve, air being admitted above each piston by means of a port in the latter, which coincides with a similar port in the top of each connecting rod, during the suction stroke; and near the end of this stroke the piston overruns the ports cut through the cylinder wall, as shown in figs. 143 and 144, thus making direct communication between the cylinder and the inside of the compressor casing, which is arranged to form a suction chamber. Messrs. Reavell claim that this feature alone results in a gain of at least 5 per cent in the volumetric efficiency as compared with compressors having spring-loaded valves, the cylinders being filled with air at atmospheric pressure at each stroke, instead of a reduced pressure due to the resistance of the valve springs. A special feature about the construction of this quadruplex compressor is the simplicity of construction and the ease with which the machine may be dissected for examination or repair, for on removing the nut which retains the end cap on the crank pin the whole of the connecting rods and pistons can be removed without the use of a spanner. The method by which the connecting rod can be removed is clearly

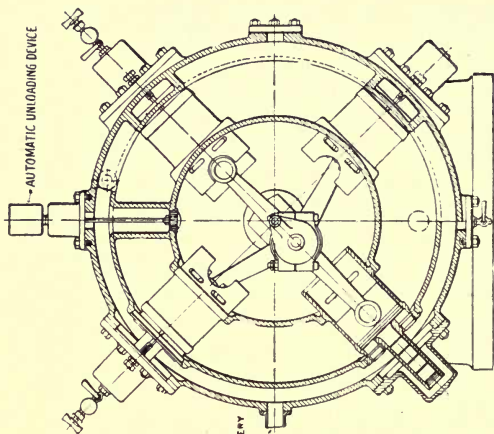

FIG. 144.

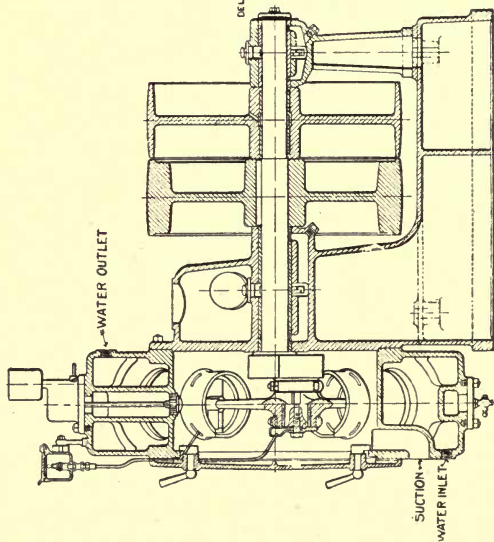

FIG. 143.

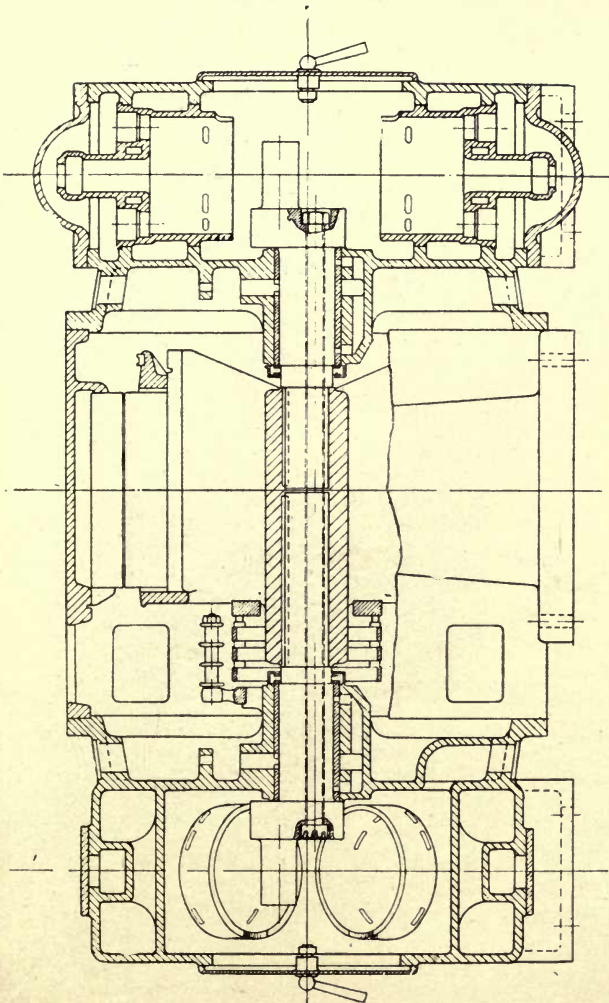

FIG. 145.

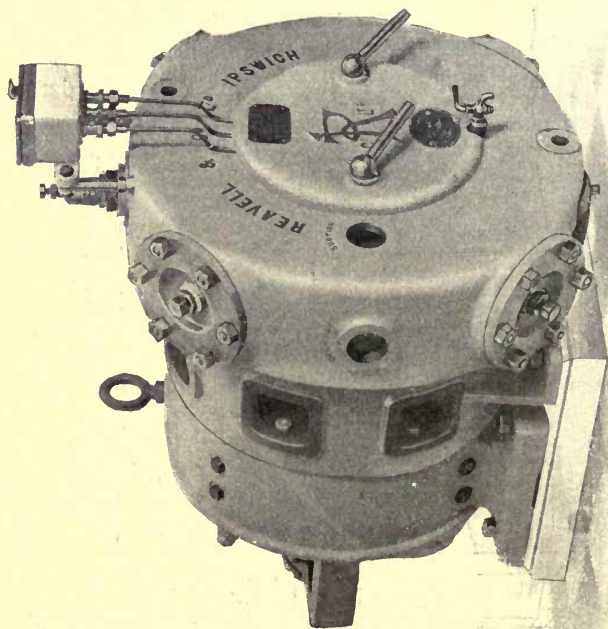

FIG. 146.



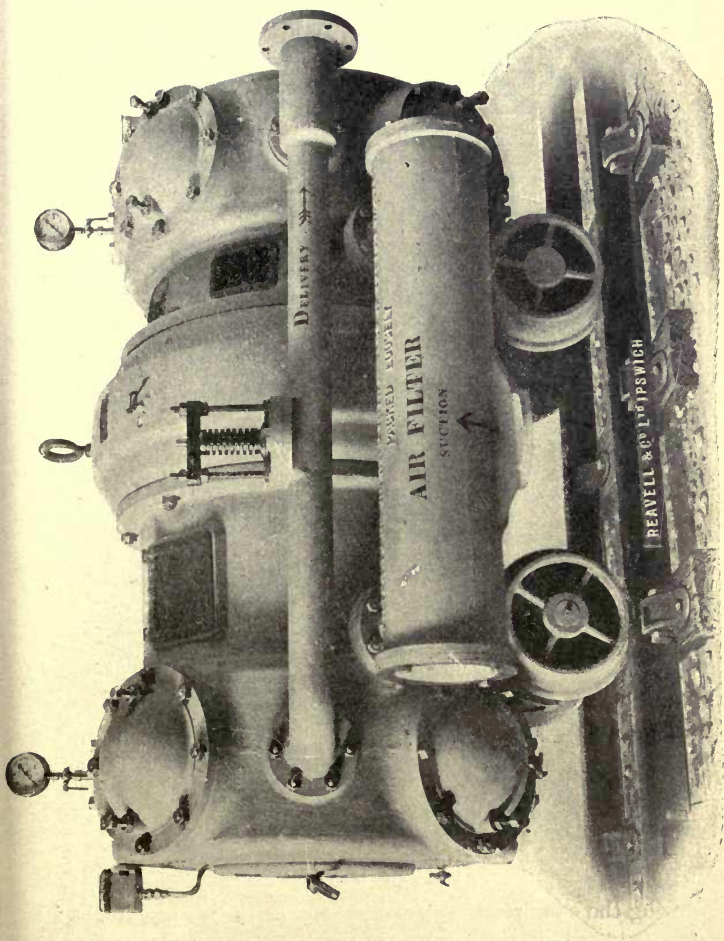

FIG. 147

shown in figs. 148, 149, and 150. The delivery valves are fitted at the outer end of each cylinder, and they open



FIG. 148.



FIG. 149.

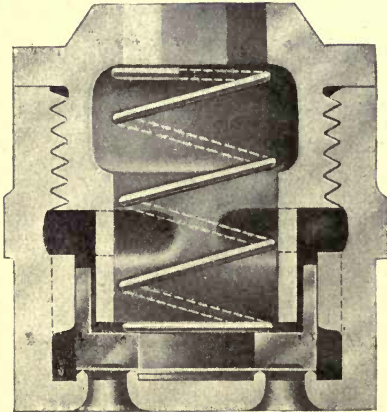

FIG. 151.

during the compression stroke as soon as the air has reached the required delivery pressure, and through them the air passes to the delivery belt or passage shown, from which it

may pass away through any of the four openings provided. These valves are made from steel, and are very light. By using a number of valves to each cylinder their weight and lift are reduced to the minimum, thus ensuring freedom

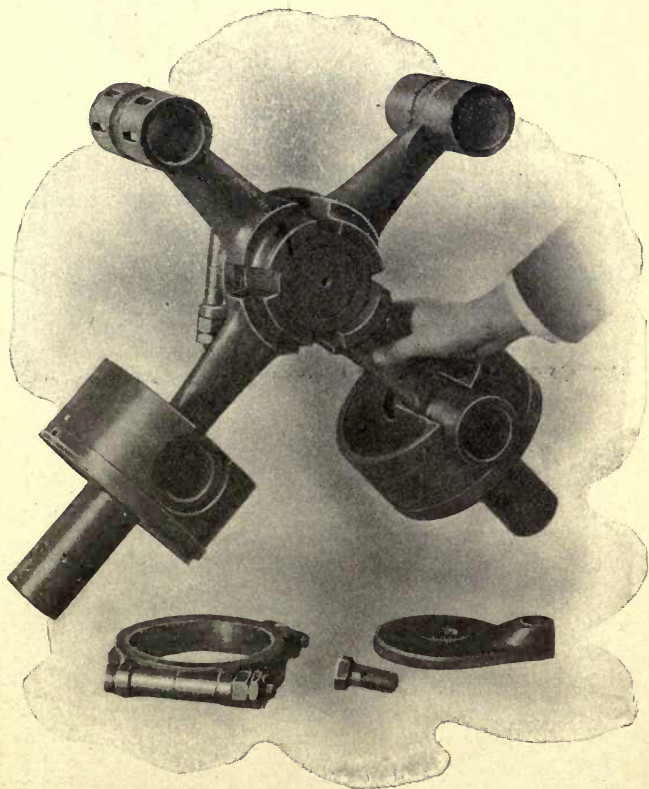

FIG. 150.

from undue wear and silence in working. This valve, with seat, cap, and spring, is shown in fig. 151. The annular part of the casing, figs. 143 and 144, forms a water jacket.

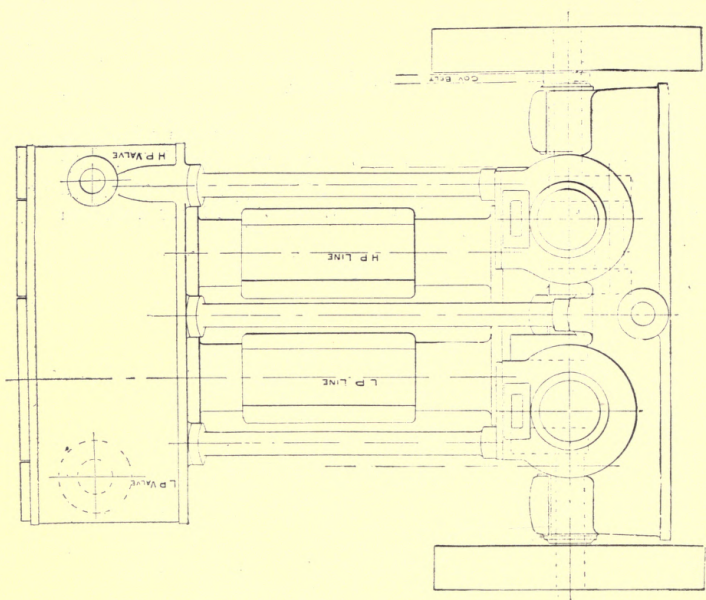

FIG. 153.

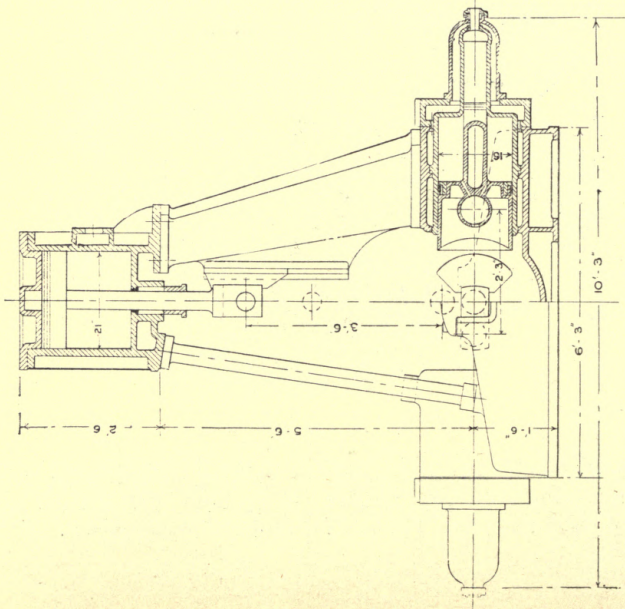

FIG. 152.

Messrs. Reavell also construct a type of compressor having vertical compound steam cylinders and horizontal compressing cylinders. One of these is shown in figs. 152 and 153.

41. *Air Compressor Delivery Valve constructed by the Gutehoffnungshütte, Oberhausen a. d. Ruhr.*—Figs. 154 and 155 show one of four delivery valves for the two air-compressing cylinders of a twin air compressor. The former is a sectional elevation, the latter a plan, the upper part of which shows the valve guard, numbered 2, as seen from below the lower part showing the valve seat 3, seen also from below. The parts are all numbered, 1 being the valve-box cover of cast iron, 2 the valve guard or stop of the same metal, 3 the valve seat of cast steel, while 4 and 5 are two rings of steel plate forming the valve. There are eight spiral springs, numbered 6 and 7, the former exercising a force of 12 lb. when they are compressed about  $\frac{1}{2}$  in., and the latter 21 lb. for the same compression. These springs are coiled round 8 and 9, studs upon which grooves are cut for the ends of the spiral springs. The valve guard is fitted upon a central bolt 10, and a stuffing box is fitted in the centre of the cover. The inside diameters of the two rings are 240 and 120 mm. or 9.45 and 4.72 in. The rings are 30 mm. or 1.18 in. in width. Figs. 156 and 157 are indicator diagrams from air-compressing cylinders made by this firm, while 158 and 159 are those from the steam cylinders. The mean pressure  $p$  is given in atmospheres. The horse power of the air cylinders is 923, and that of the steam cylinders is 1,157, so that the mechanical efficiency is about 80 per cent. The volumetric efficiency is 87 per cent, and the pressure to which the air is compressed is 6.6 atmospheres, and the average mean pressure per square inch of the four diagrams is 33.3 lb., the ideal mean pressure

$$p_i = .87 \times p_2 \text{ hyp log } \frac{p_1}{p_2}$$

the volumetric efficiency being .87 ;

$$p_i = .87 \times 14.7 \times 2.3 \log 6.6 = 24 \text{ lb.}$$

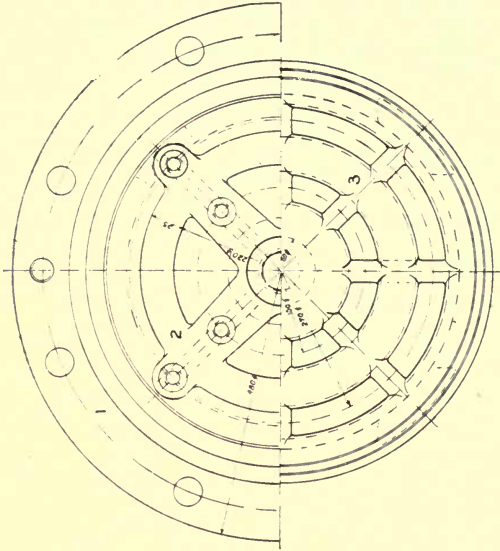

FIG. 155.

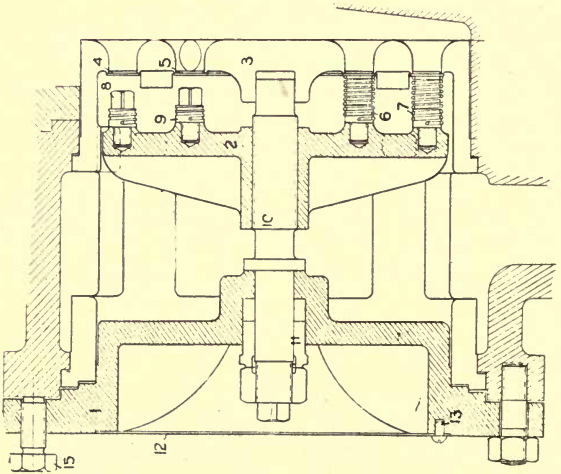

FIG. 154.

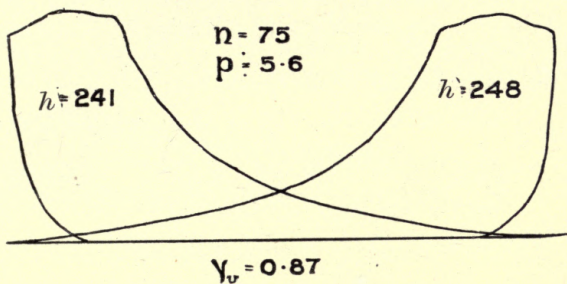

FIG. 156.

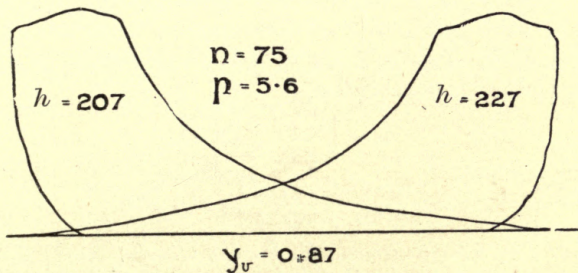

FIG. 157.

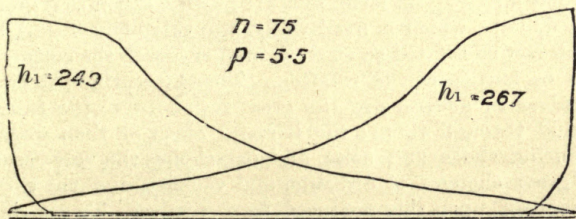

FIG. 158.

Hence the air efficiency

$$\eta_2 = \frac{24}{33.3} = 72 \text{ per cent,}$$

and the total efficiency of the engine is

$$\eta = .80 \times .72 = .576, \text{ or } 57.6 \text{ per cent.}$$

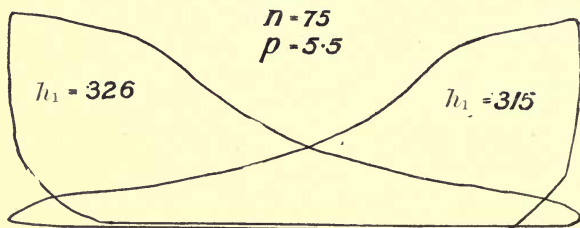

FIG 159.

Taking the diagram in which the indicated horse power is 241, and using the equation,

$$\begin{aligned} n &= \frac{\log p_1 - \log p_2}{\log v_2 - \log v_1} \\ &= \frac{\log 6.56 - \log 1}{\log 98 - \log 23.75} = 1.325. \end{aligned}$$

42. *Professor Guttermuth's Spring Clack Valves.*—These are constructed by the Humboldt Engine Works, Kalk, near Cologne, and are shown in figs. 160, 161, and 162. The valve itself consists of a thin plate, which for 50 atmospheres need not exceed 1 mm. in thickness. It is coiled at one end into a spiral form, and fits at this end into a groove in a spindle, which is fixed whilst the valve is working, but which can be rotated so as to tighten or loosen the spring for high or low speeds of rotation. The three principal faults of valves in general are the great resistance to the passage of fluid through them; the harmful effect of their masses, producing shock and noise, and destroying the valve seats; the great changes of direction and velocity, and the eddies consequent upon this produced by the valve. To get rid of these Professor Guttermuth carefully studied the working of



valves, both practically and theoretically, and claims to have designed one in which all these faults are reduced to the minimum possible. The mass of the valve is very small, as is also the tension of the spring, while the flow through the

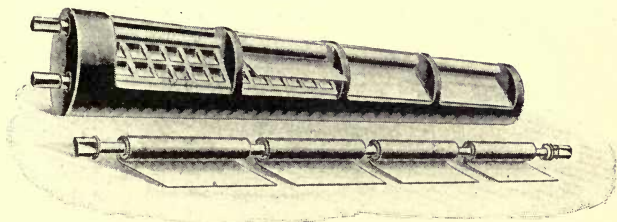

FIG. 160.

seat and past the valve is so arranged that there is very little change of velocity and direction, and consequently very little loss by the production of eddies. This is very clearly shown in fig. 161, which contains a transverse and longitudinal section of an air-compressor cylinder. In the

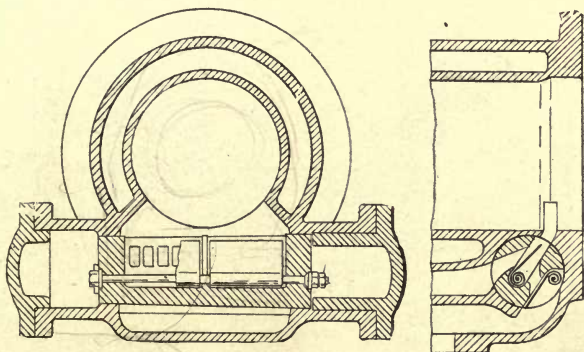

FIG. 161.

latter the air enters from the left, and it will be seen how small is the change of direction in its passage through the valve, while the same holds good for the discharge. The opening of the valve is not affected appreciably by the

tension of the spring, but depends upon the volume flowing through it. The spring is necessary merely to close the valve with sufficient rapidity. The valves are noiseless in their action, and easily accessible. Fig. 162 shows their arrangement for an ammonia compressor where a small

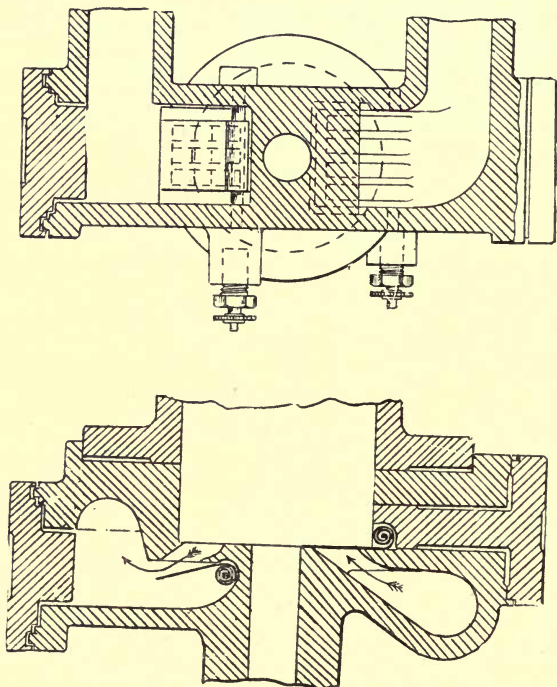

FIG. 162.

clearance is necessary. Two small covers are arranged to give access to the valves. Fig. 163 gives the diagrams of a compound air compressor made at the Humboldt works, compressing to seven atmospheres. The diameters of the steam cylinders are 630 and 950 mm. (24.8 in. and 37.4 in.), and those of the air-compressing cylinders 400 and 650 mm.

(15.75 in. and 25.6 in.), while the stroke is 1,000 mm. (39.4 in.).

The speed at which the diagrams are taken is 75 revolutions per minute, but the engine is capable of discharging 5,000 cubic metres of free air per hour. The ease with which the valves work is shown by the fact that the pressure on the diagram only exceeds seven atmospheres by about  $3\frac{1}{2}$  lb. at most. The advantage of compounding is also shown by the great reduction in volume of the air in the intermediate reservoir. The mean volume of air discharged from the low-pressure cylinder is 0.436 of its volume, while that drawn into the high-pressure cylinder is

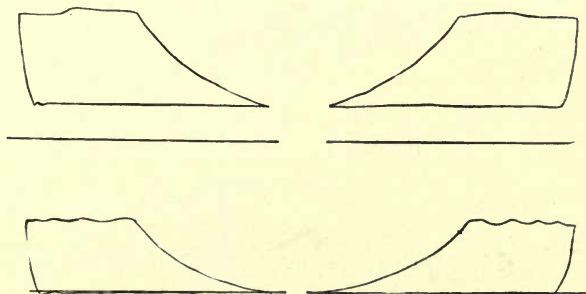

FIG. 163.

.95 of its volume. It follows that the air discharged from the low-pressure cylinder has a volume whose ratio to that of the air drawn into the high-pressure cylinder is

$$\frac{\cdot436 \times (650)^2}{\cdot95 \times (400)^2} = 1.21.$$

The pressure at discharge from the low-pressure cylinder is 27.45 lb., and from the high-pressure cylinder 88.2 lb., both above the atmosphere. The average volumetric efficiency of the low-pressure cylinders is 94 per cent; that of the high-pressure cylinders is  $94\frac{1}{2}$  per cent. The mean pressures from the low and high pressure cylinders are 16.12 and 30.65, so that the mean pressure referred to the low-pressure cylinder is 29.57 lb. per square inch.

The ideal mean pressure that would be obtained with isothermal compression and volumetric efficiency of .94 is

$$\cdot 94 \times 14.7 \text{ hyp log } 7 = 26.85.$$

The air efficiency

$$\eta_2 = \frac{26.85}{29.57} = 91 \text{ per cent,}$$

a very good result, showing the advantage of compounding.

If we assume that the mechanical efficiency of the engine is 80 per cent (and it is hardly likely to be less), we get a total efficiency of 72.8 per cent; while with an average mechanical efficiency of 85 per cent it is 77.2.

The value of the exponent  $n$  in the low-pressure cylinder is calculated from the formula—

$$n = \frac{\log p_1 - \log p_2}{\log v_2 - \log v_1},$$

where  $v_2$  is the length on the diagram between the feet of the compression and expansion curves, and  $v_1$  is the length measured parallel to the atmospheric line between these curves from the highest point on the expansion curve; while  $p_1$  must then be chosen as the pressure corresponding to this point, and  $p_2$  is the pressure at the foot of the compression curve—

$$n = \frac{\log 40.2 - \log 14.7}{\log 90.5 - \log 41.25} = 1.28,$$

mean values of  $p_1$ ,  $p_2$ ,  $v_1$ ,  $v_2$  being taken from the two diagrams.

In the high-pressure diagram we get

$$n = \frac{\log 85.2 - \log 39}{\log 90 - \log 45} = 1.125.$$

The following dimensions of this engine will be of interest:—

Piston-rod diameter .....	125 mm.
Tail-rod diameter .....	115 mm.
Crosshead gudgeon diameter .....	130 mm.
Bearing length .....	250 mm.

Length of connecting rod.....	2,500 mm.
Diameter at small end .....	120 mm.
Diameter at large end .....	150 mm.
Overhang of crank .....	630 mm.
Diameter of journals .....	325 mm.
Length of journals .....	540 mm.
Diameter of shaft at flywheel .....	430 mm.
Length of flywheel boss .....	600 mm.
Diameter of crank pin... ..	190 mm.
Length of crank pin.....	270 mm.
Diameter of flywheel .....	5,000 mm.
Width of rim .....	300 mm.
Radial depth.....	300 mm.
Number of arms .....	8
Centres of cylinders .....	4,450 mm.
Diameters of side shaft .....	80 and 90 mm.
Diameter of mitre bevel wheels .....	640 mm.
Diameter of high-pressure steam and exhaust double-beat valve .....	180 mm.
Diameter of low-pressure steam and exhaust double-beat valve .....	290 mm.
Diameter of high-pressure steam pipe.....	175 mm.
Diameter of high-pressure exhaust pipe .....	200 mm.
Diameter of intermediate receiver .....	835 mm.
Length of intermediate receiver .....	2,540 mm.
Diameter of low-pressure steam pipe .....	275 mm.
Diameter of low-pressure exhaust pipe .....	325 mm.
Diameter of low-pressure air cylinder suction pipe .....	300 mm.
Diameter of low-pressure air cylinder dis- charge pipe .....	275 mm.
Two intermediate receivers—diameter and length .....	575 and 4,200 mm.
Diameter of high-pressure air cylinder suction pipe .....	225 mm.
Diameter of high-pressure air cylinder dis- charge pipe .....	175 mm.
Thickness of high-pressure cylinder .....	30 mm.
Thickness of high-pressure liner.....	35 mm.
Thickness of high-pressure air cylinder .....	25 mm.

Thickness of high-pressure air liner .....	32 mm.
Total length of low-pressure air valves .....	1,000 mm.
Total length of high-pressure air valves.....	605 mm.
Number of passages in low-pressure gratings	40
Area of each passage about .....	33 × 42 mm.
Number of openings in high-pressure gratings	30
Area of each passage .....	27 × 30 mm.

The steam valves are double-beat, and are actuated by eccentrics from a side shaft. Each cylinder has four valves—two admission above and two exhaust beneath. A trip gear is used, the cut-off in the low-pressure being adjustable by hand, and that in the high-pressure being controlled by the governor.

43. *The Boreas Air Compressor, constructed by Messrs. Alley and MacLellan.*\*—This is a two-stage compressor. The air enters the upper end of the cylinder through valves in the cover, fig. 164, on the down stroke, and is discharged on the up stroke through valves at the side, fig. 165, into a long pipe, which forms a receiver and intercooler between the upper and lower side of the piston. As shown in fig. 165, this pipe is immersed in a tank in the base of the machine, which forms a reservoir for the water circulated through the cylinder jacket. The lower side of the piston has a trunk, so that the air is again compressed on the down stroke, the suction and discharge valves being shown in fig. 165 at the side of the cylinder. These, as also the discharge valves for the upper side of the piston, are contained in boxes quite distinct from the cylinder proper, and are readily accessible for inspection and renewal. The crank is lubricated on the splash system, and is completely enclosed. Other working surfaces are kept oiled by a system of forced lubrication worked by the small pump without valves, which is at the right end of the crank shaft. This draws oil from a well in the casing through a filter, and delivers it to the different bearings. The oil is returned again to the well from oil catchers. In order to regulate the machine there is a pneumatic switch, adjusted for any desired pressure, which, when this pressure is reached on

\* *Engineering*, October 4th, 1903.

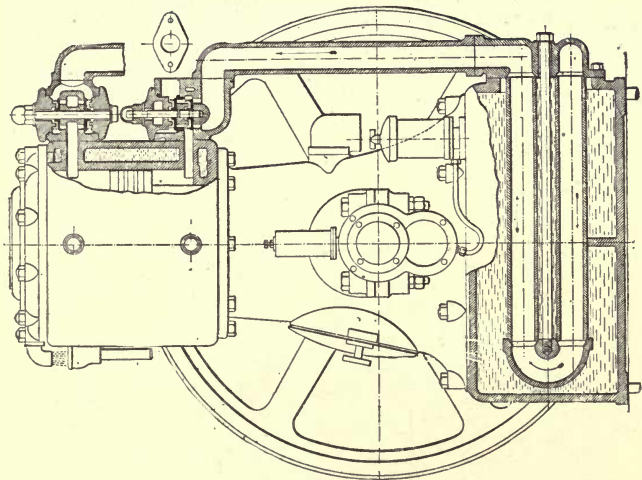

FIG. 165.

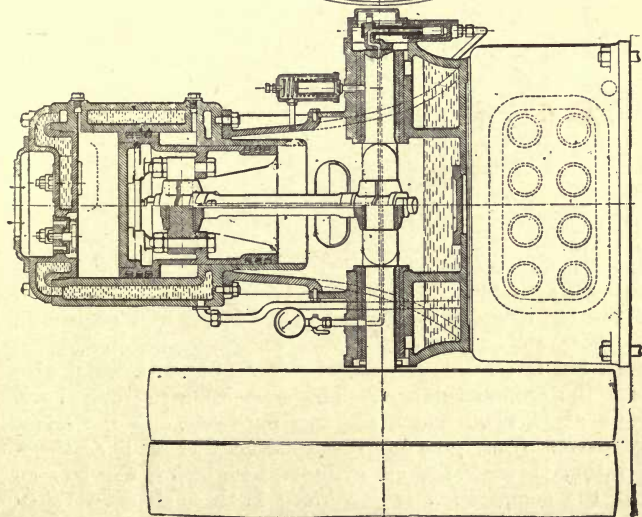

FIG. 164.

the receiver, turns the air discharged from below the piston back to its upper side, so that the air simply circulates through the machine, no work being done except that necessary to overcome frictional resistances. The pressure is thus very closely regulated.

44. *The Brotherhood Air Compressor.*—Fig. 166 is a front elevation of a small compressor constructed by this

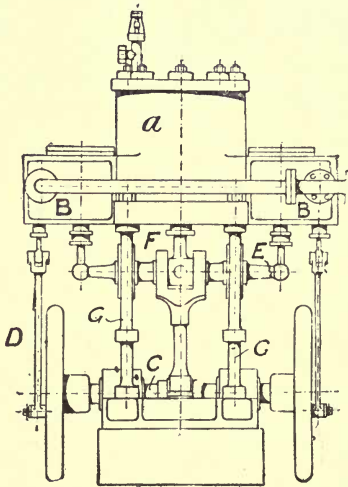

FIG. 166.

firm for a pressure of 125 atmospheres. A is the compressing cylinder, and B are two steam cylinders. The rod of the air cylinder is attached to the centre of a crosshead, to whose ends the steam piston rods are connected. The crosshead is guided vertically by four guides G, which also form the engine columns. The connecting rod drives the crank shaft, upon which are two flywheels, and the valves are driven from pins on these. Fig. 167 is a sectional elevation through the air cylinder, by which it will be seen that the compression is performed in three stages. When the piston D descends, air is drawn in above it through the



valve in the cover. On the up stroke this air passes through valves in the piston into the annular space A, so that, its volume being reduced, its pressure rises; on the down stroke it is compressed in this annular space, and passes

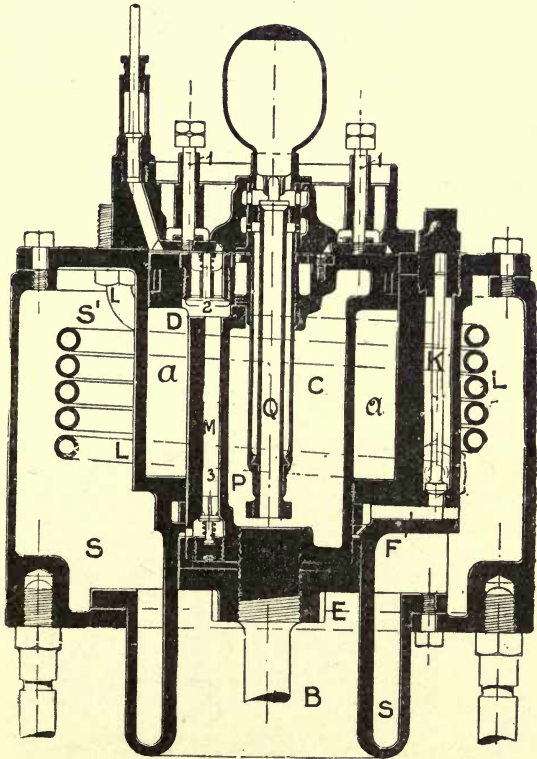

FIG. 167.

down passages M into the annular space above the piston E, so that its pressure is still further increased. On the up stroke the air is still further compressed and passes the valve K, and flows in a spiral tube L, which is enclosed in

a tank of water and connected to the air reservoir. The cooling water is not only sprayed into the cylinder with the inflowing air, but also circulates within the piston in the

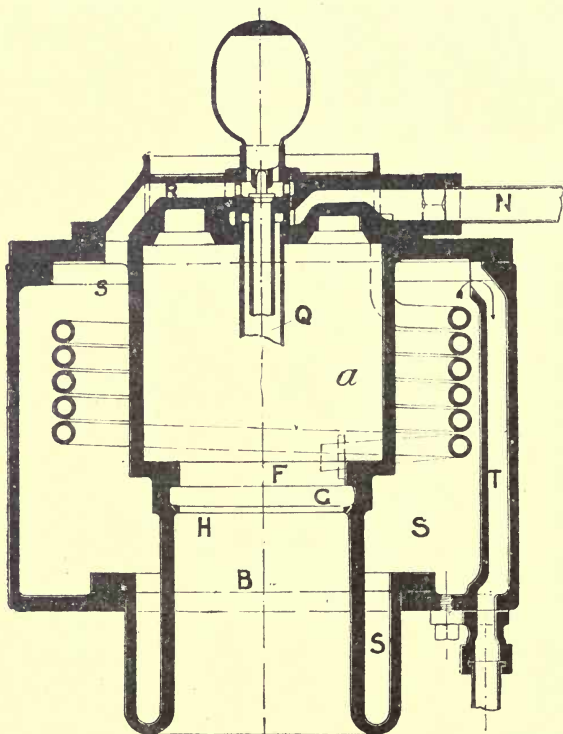

FIG. 168.

space C and the tank S. The manner in which the circulation is carried out is partly shown in fig. 168, which is a sectional elevation on a plane perpendicular to the axis of the shaft. The water enters the pipe N, and is drawn into the annular space surrounding the pipe Q, the water flowing

in as the piston D descends, and passing the valve P into the space C. On the up stroke the water ascends Q, passes

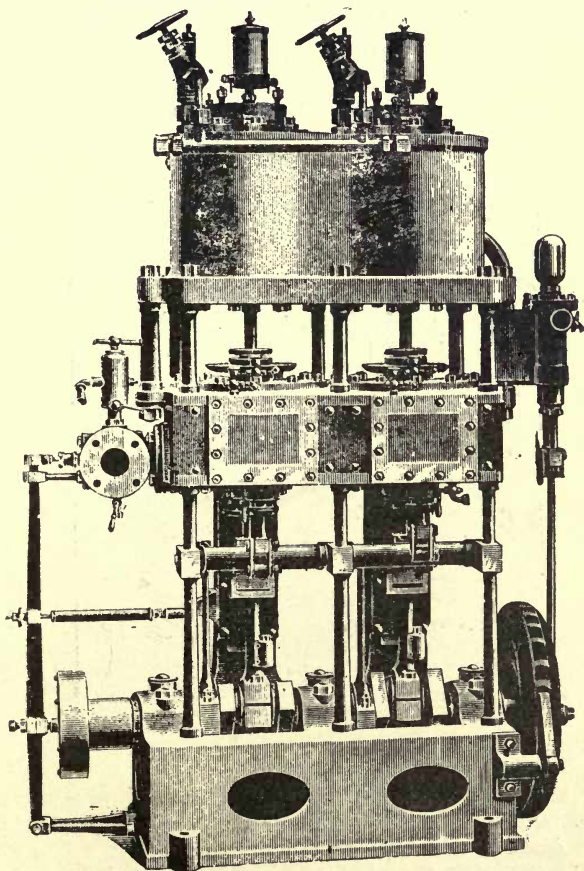

FIG. 169.

the valve at the top, and flows by R into the tank S surrounding the air cylinder, which it leaves by the passage

T. This type is capable of compressing 10 cubic feet of air per hour at a pressure of 100 atmospheres, and weighs only 5 cwt. A larger one, fig. 169, with two compressing cylinders, has a capacity of 20 cubic feet of compressed air

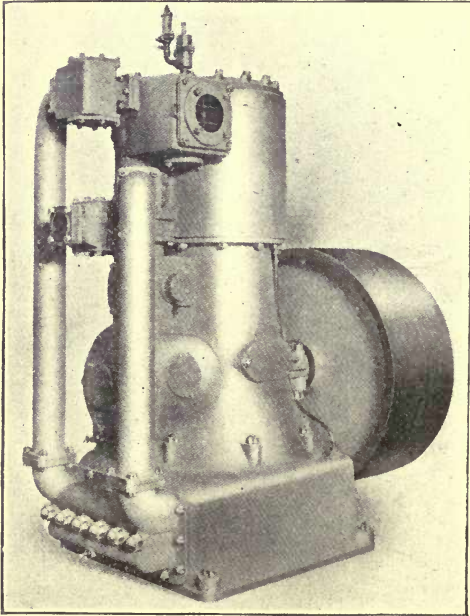

FIG. 170.

per hour, and both can, if necessary, work up to a pressure of 2,500 lb. per square inch. Three-cylinder engines are also constructed.

45. *Sentinel Air Compressors, constructed by Messrs. Alley and MacLellan of Glasgow.*—Through the courtesy of Messrs. Alley and MacLellan we are able to describe their latest improvements in this type of compressor. Fig.

170 shows an outside view, and fig. 171 a sectional elevation of their series B two-stage vertical type, fitted with intercoolers and forced lubrication. In fig. 170 the suction port is visible in the centre of the top, and the discharge to the left. It will be seen from fig. 171 that the piston valve has three pistons; on the down stroke of the main piston the piston valve is above mid-stroke and is admitting air to the top of the main piston from the space between the top and middle piston valves which is in

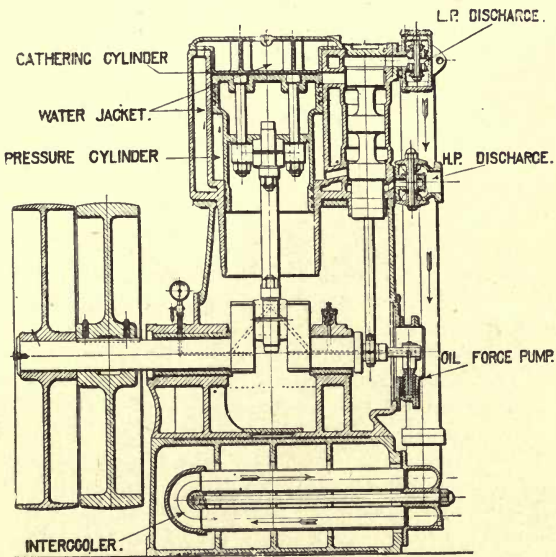

FIG. 171.

connection with the suction port. In the annular space below the main piston the air is being compressed, and when the valve has risen sufficiently it flows to the H.P. discharge valves, lifting these when compressed to the reservoir pressure. The piston valve closes the discharge port just at the end of the stroke, and descending further,

forces the air beneath it through the discharge valves; at the same time these latter are seated very quietly because they have beneath them a cushion of high-pressure air. On the up-stroke air is forced from the large space above the main piston into the annular space below it, to reach which it has to pass through the intercooler beneath the engine, which consists of pipes immersed in a reservoir of water, from which that used in the cylinder water jacket is drawn. Lubrication is effected by means of the force pump at the

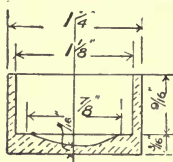

FIG. 172.

right end of the crank shaft. This type is constructed in five sizes, delivering from 100 to 600 cubic feet of free air per minute. Messrs. Alley and MacLellan also make this class of compressor with two or three cylinders delivering a proportionate quantity of air. The valves in fig. 171 are thin rings of steel, but the types shown in fig. 172 are an improvement on these. They are of steel, drop-forged, and are kept on their seats by springs. Fig. 173 shows the piston and discharge valves, and also the arrangement of the automatic air-inlet control valves. On the left of the piston valve will be seen the balanced throttle valve, through which the air from the suction port must pass to reach the piston valve. The throttle valve is raised or depressed by means of a spindle, upon the top of which is a piston, called the control piston, forced down by a spring, so that unless a sufficient air pressure acts underneath it the throttle valve will remain open. As long as the pressure in the reservoir or discharge pipes does not exceed that required by 2 lb., there is only atmospheric pressure under the control piston, for the pipe connecting it to the air governor on its left is connected to the atmosphere by means of the

adjustable leak screw. But when the pressure rises above this the air governor admits air underneath the control

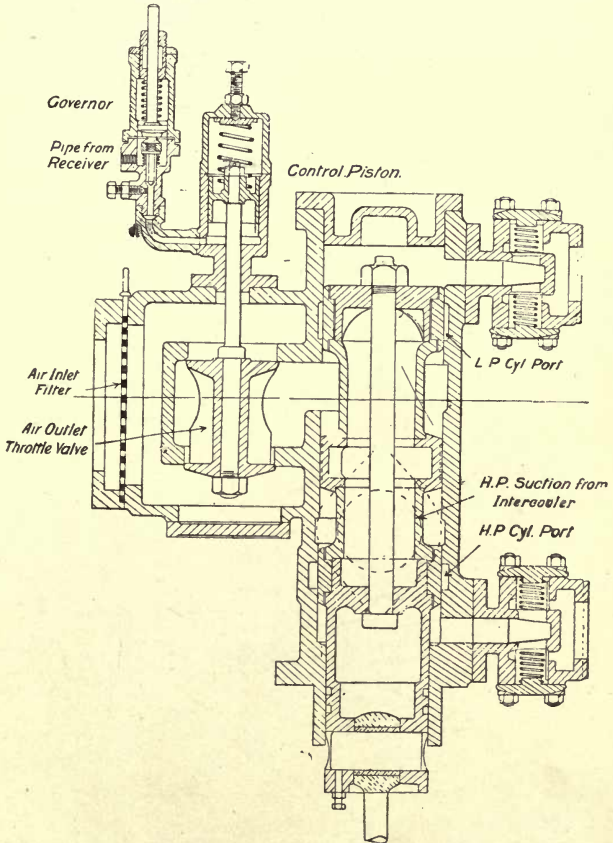

FIG. 179.

piston and raises it, thus closing the throttle valve, so that the only work required to drive the machine is that needed

to overcome friction. The air governor is shown to a larger scale in fig. 174 ; it consists of a flexible copper diaphragm held between the two parts of the casing and loaded on the top by an adjustable spring ; the function of the bolt in the centre is to reinforce the diaphragm and to receive and

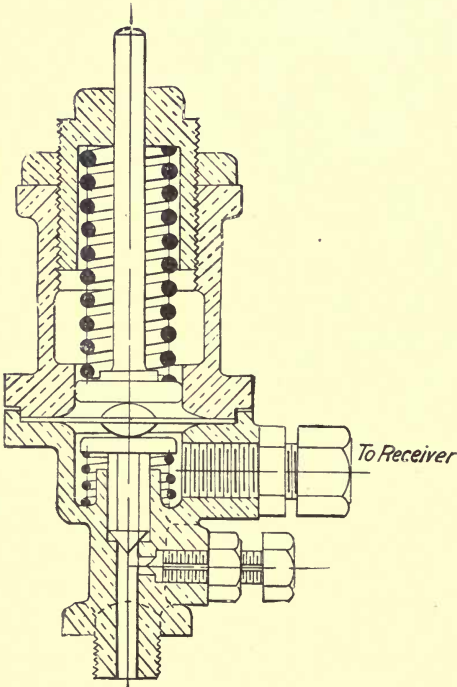

FIG. 174.

transmit the load of the spring to the small valve at the bottom with a conical head ; the connection with the receiver is on the left in fig. 173, and on the right in fig. 174, just above the valve. When the pressure rises 2 lb. above the normal the diaphragm is raised, and the valve is



lifted by the spring beneath; air then flows underneath the control piston and closes the throttle valve. In the steam driven or "Series C" compressors, a further connection from the air governor controls an equilibrium throttle valve on the steam inlet, which closes simultaneously

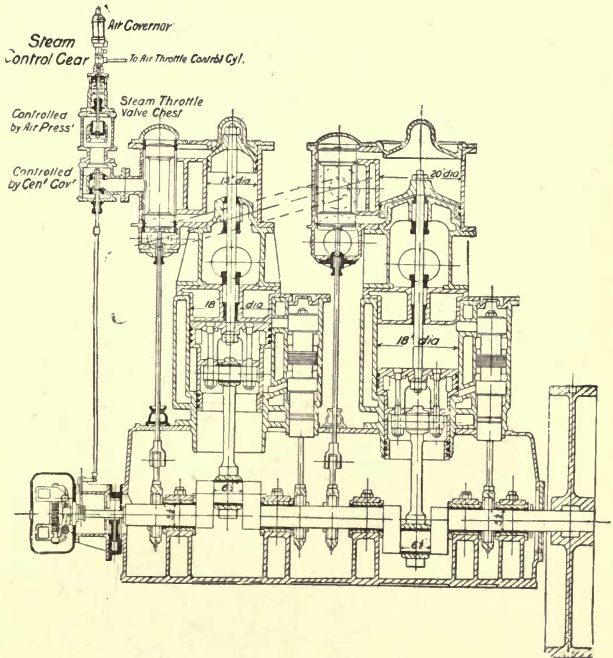

FIG. 175.

with the air throttle. A bye-pass is arranged, which supplies sufficient steam to keep the machine running light until the steam and air throttles re-open and the load is resumed. This ensures the economical running of the compressor whether light or under load. Fig. 175 is a sectional elevation of a series D compound double air compressor with steam cylinders 13 in. and 20 in. diameter, air cylinders

18 in. diameter, with a stroke of 10 in. The piston rods are  $2\frac{1}{4}$  in. diameter, the crank-shaft is  $5\frac{1}{2}$  in., and the crank pins are  $6\frac{1}{2}$  in. long. The cranks are set at 180 deg. The steam valves are piston valves. The speed governor is on the left

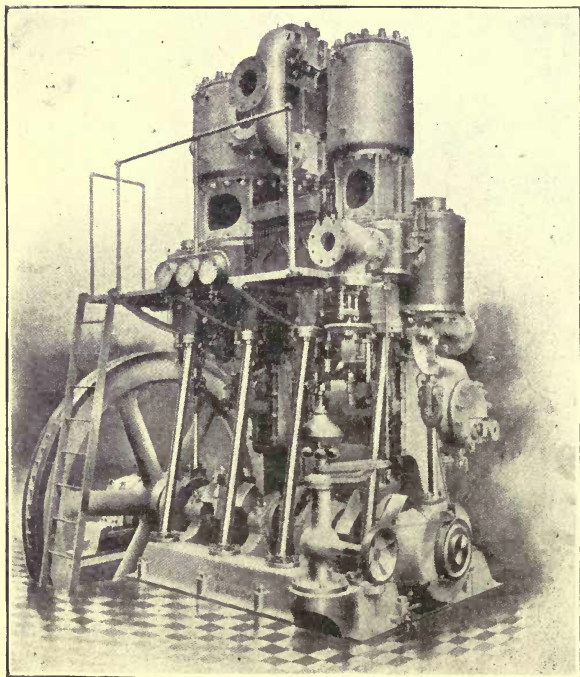

FIG. 176.

end of the shaft, but in addition to this, in the left-hand upper corner of the figure, is the air governor for shutting off steam, except that through the bye-pass sufficient to keep the engine in motion. When the required pressure is reached this valve is shut down by the control, and

immediately after the air suction is shut off. On the pressure again falling the steam equilibrium valve opens first, running the machine up to speed, and then the air

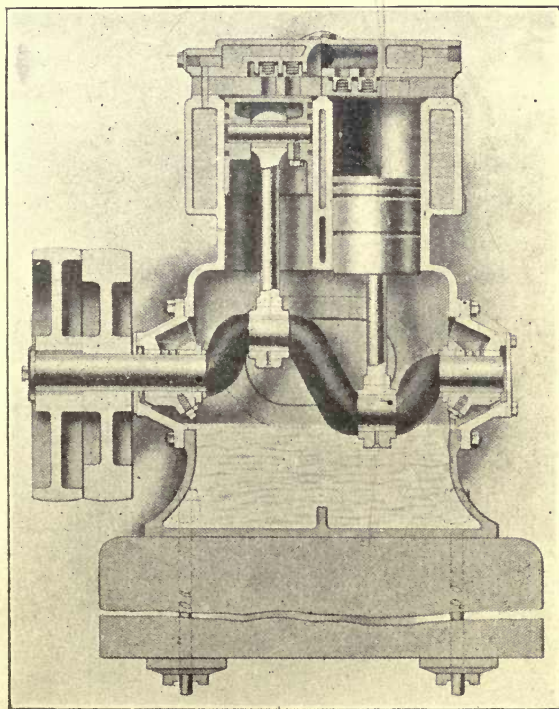

FIG. 177.

control opens, taking up the compression again. Fig. 176 shows a series J air compressor. These are made of the following capacities in cubic feet per minute: 500, 1,200, 1,500, 2,000, 2,500, 4,000, and 5,000.

Where only a small amount of compressed air is required, or where it is not constantly used, or for low-pressure work, Messrs. Alley and MacLellan recommend their "Sentinel

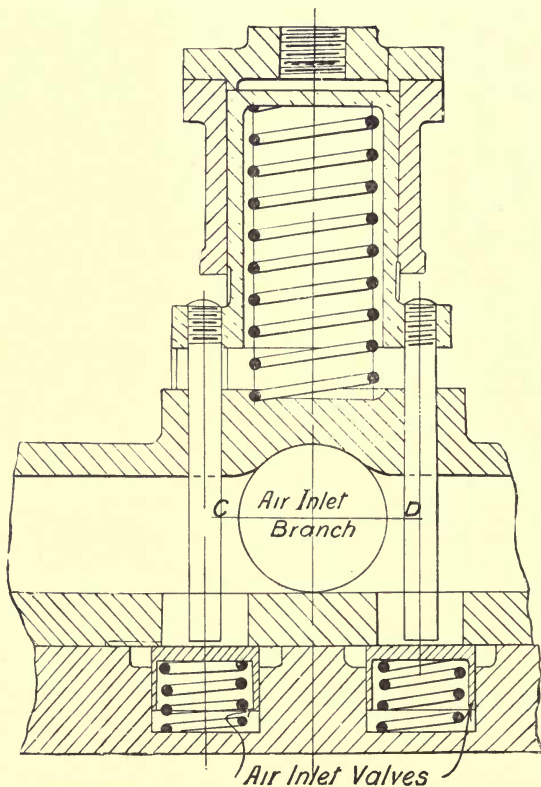

FIG. 178.

Junior" single-stage air compressor. One of these is shown in fig. 177. The machine is completely enclosed, and the pistons are single-acting. The valves, which are similar to those shown in fig. 172, are placed in the cylinder cover and

are self-acting. There are only six bearings in the machine ; these are of ample proportions, and working as they do, protected from flying grit and dirt and in an oil bath, run for very long periods without attention. The valves work successfully at 1,200 revolutions per minute. This type of

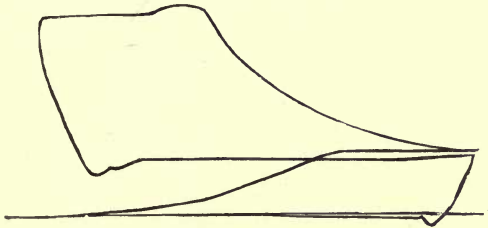

FIG. 179.

compressor can be fitted with a governor which is a modification of that already described, the control piston being shown in fig. 178. When this is depressed by air pressure it forces open two air inlet valves by means of the two  $\frac{3}{8}$  in. spindles fastened to it. Thus the compressor continues to run without doing any work. Want of space prevents the description of several other types of compressor constructed by this firm.

Fig. 179 is a diagram from a two-stage compressor of series B, taken at 225 revolutions per minute. The receiver pressure is 100 lb. per square inch and the scale is  $\frac{1}{100}$ .

46. *High-pressure Air Compressor, by MM. Elwell Fils, Plaine St. Denis, Paris.*\*—Fig. 180 is a sectional elevation through both cylinders. Figs. 181 and 182 are also sectional elevations through the small and large cylinders, both at right angles to the shaft, and fig. 183 is a sectional elevation through the large cylinder. The compressor is intended for a pressure of 1,430 lb. per square inch, and the air is compressed in four stages. On the down stroke of the large piston the air is drawn into the cylinder through the eight valves E, E, fig. 183, in the cover, which are closed by helical springs. A spray of water

\* From the *Engineer*, March 16th, 1894.

is introduced at the same time, and a small quantity of oil is drawn in from the lubricator. When the piston ascends

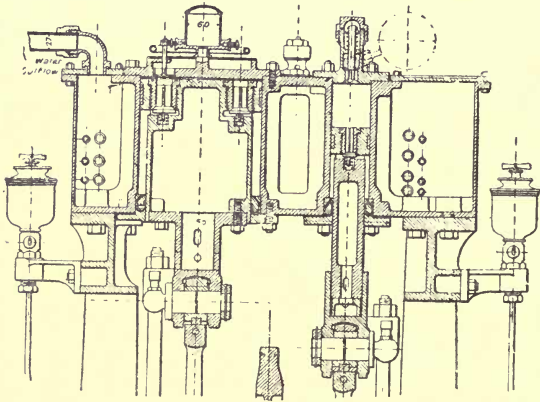

FIG. 180.

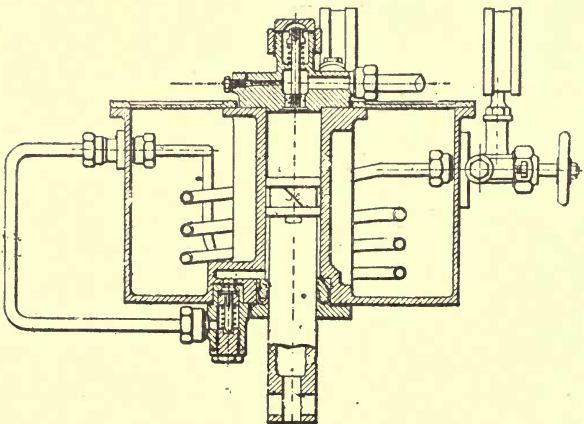

FIG. 181.

it compresses the air above the piston until it is able to open the valves F in the piston and to enter the annular space B,

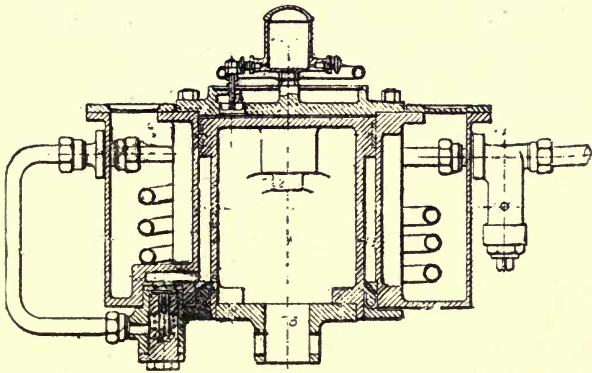

FIG. 182.

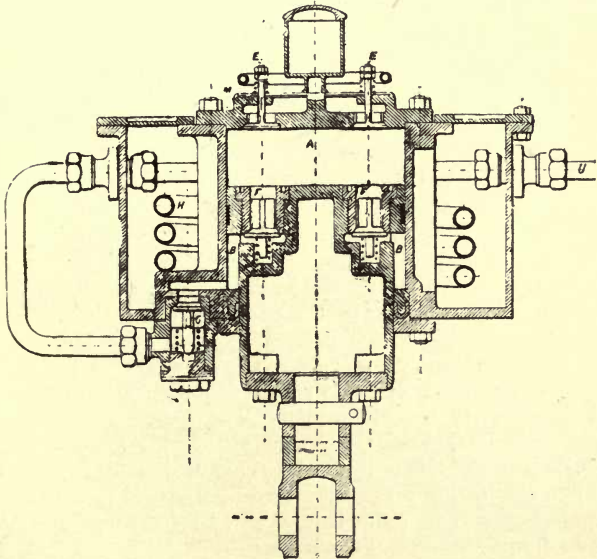

FIG. 183.

so that compression goes on with diminishing volume until the end of the stroke, when the pressure is about 57 lb. On the return stroke the pressure is raised to 142 lb., and the air is forced into a coil of pipes connecting the large with the small cylinder, and as this is in a tank filled with water which is kept in motion by a pump, the air is cooled before it enters the small cylinder by the central valve at the top. The air passes through the valve in the small piston on its up stroke into the annular space beneath, and its pressure is then raised to 430 lb., and on the return stroke it is discharged at 1,430 lb. It is to be noticed that the water introduced into the first cylinder passes through all the stages, and is always above the valves. It is claimed by the makers that this is a feature of considerable importance in high-speed machines, because there is no danger of knocking a cylinder end out, or breaking the piston if too much water should be admitted. These compressors are specially designed for charging torpedoes, and are used in the French Navy. The leading dimensions of the machine shown are :—

Diameter of large air piston....	210 mm. (8·26 in.)
Diameter of trunk .....	180 mm. (7·1 in.)
Diameter of small piston .....	66 mm. (2·6 in.)
Diameter of trunk .....	55 mm. (2·17 in.)
Diameter of steam pistons.....	180 mm. (7·1 in.)
Stroke of all pistons .....	150 mm. (5·9 in.)

A general view is shown in fig. 184, in which it will be seen that the air cylinders are at the top and the steam at the bottom. The steam piston rods are connected to the air trunks by means of two rods and two crossheads, and the crank shaft is driven by two connecting rods fastened to gudgeons in the air trunks. The valves are driven by eccentrics on this shaft, and the circulating plunger pump, which is to the left of fig. 184, is also driven by it by means of two connecting rods and a lever. Another size, intended to discharge 17·65 cubic feet of air at 1,400 lb. pressure, has the following leading dimensions :—



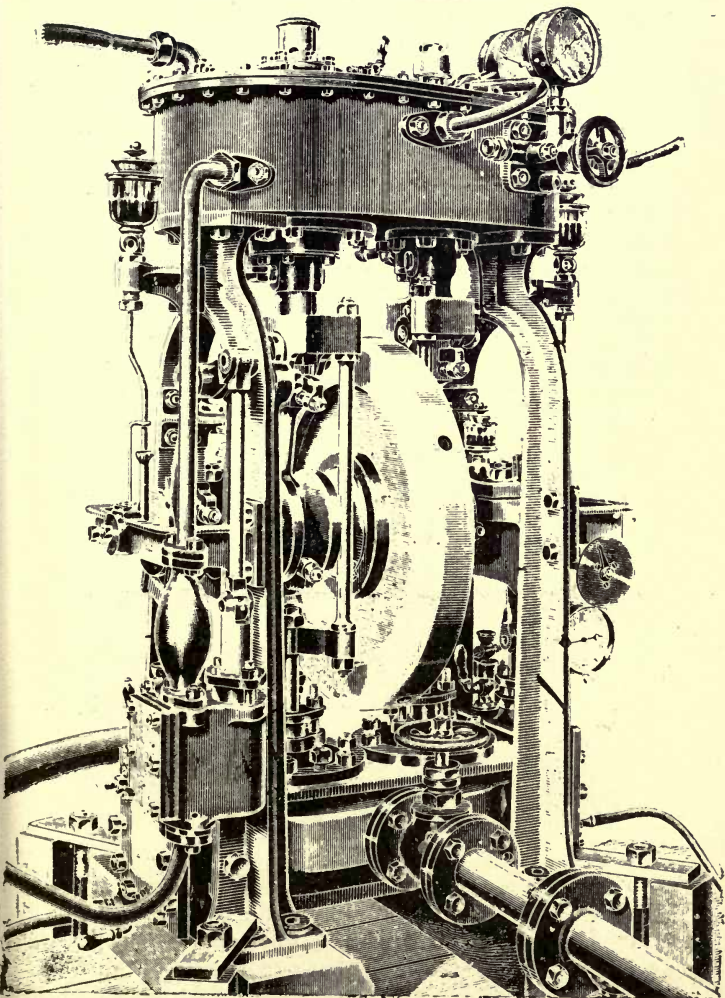

FIG. 184.

Diameter of large air piston.....	7 $\frac{3}{8}$ in.
Diameter of trunk.....	6 $\frac{3}{8}$ in.
Diameter of small piston .....	2 $\frac{5}{8}$ in.
Diameter of trunk.....	1 $\frac{9}{16}$ in.
Diameter of steam pistons .....	6 $\frac{1}{2}$ in.
Stroke of all pistons .....	4 $\frac{3}{4}$ in.
Revolutions per minute .....	300 to 350
Steam pressure....	43 lb. to 71 lb. per square inch.

47. *Air Compressor Cylinder, constructed by the Allis-Chalmers Co., Milwaukee.*—The inlet valves are of the Corliss type, and the discharge are self-acting. The wheel at the side is driven by an eccentric rod, whose end is attached to the pin, which in fig. 185 is at the lowest point

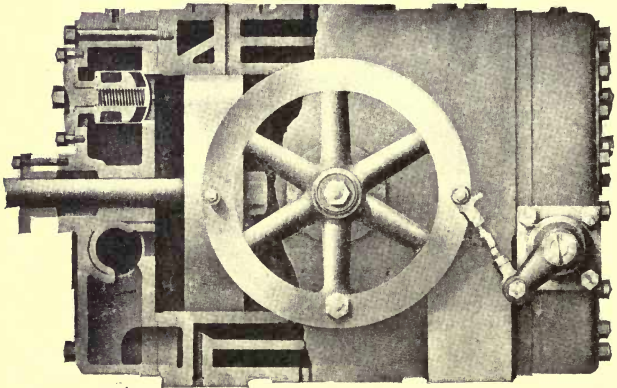

FIG. 185.

of the wheel. The connecting link and valve levers are so set that their motion is very small when the valve is closed, *i.e.*, when pressure acts upon it, so that waste of power by friction is minimised. The valve is balanced when closed, a small passage above the suction connecting the cylinder to a space at the back of the valve. The discharge valve has a

spherical seat, and is guided by a projection on the cover, which also forms a dashpot, cushioning the opening of the valve. There is also a central spring fitted in a cylindrical case with the right end closed, which presses the valve on its seat.

## CHAPTER VI.

48. *Double King Riedler Air Compressor.\**—This was constructed by Messrs. Fraser and Chalmers, of Erith, in September, 1901, for the Powell Duffryn Steam Coal Company.

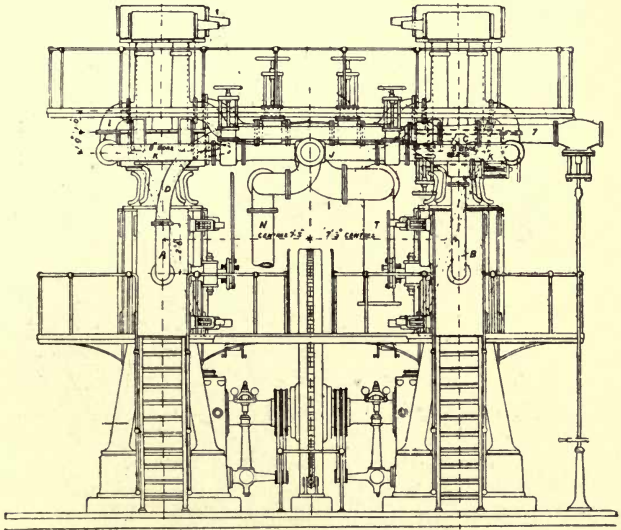

FIG. 186.

Its capacity is 8,300 cubic feet of free air compressed in two stages to 60 lb. pressure at 70 revolutions, with a boiler

\* From *Engineering*, November 14, 1902.

pressure of 95 lb., and an indicated horse power of 1,050. Figs. 186 and 187 show that it consists of two compressors side by side, with a flywheel between, whose diameter is 16 ft., and which weighs about 16 tons. Each half can, if it is desired, run independently of the other by uncoupling the connecting rods. The steam cylinders are 23 in. and 38 in., and the air cylinders 23 in. and 37 in., the common stroke being 48 in. All the air pipes to and from the cooler are fitted with Hopkinson's gate valves, so that either side may

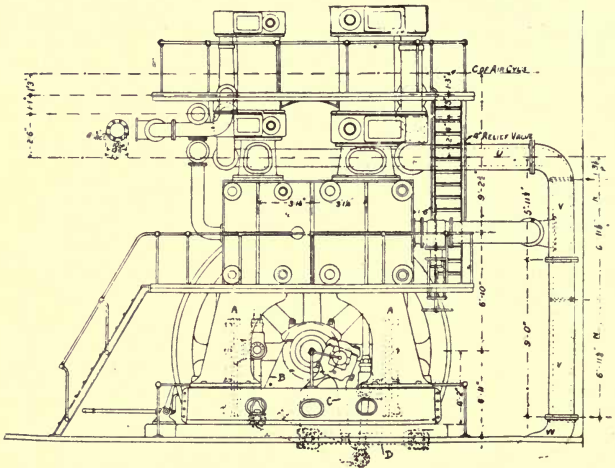

FIG. 187.

be rapidly disconnected and one side run alone. The cranks are set opposite so that the engine is balanced, and the triangular connecting rod not only reduces the height of the engine, but also gives as uniform a turning moment for each half as would be obtained with two cranks at right angles. Fig. 187 shows the connecting rod very clearly. Shoes on the lower ends of the two piston rods slide in single guides A, and are coupled by short links B to the bottom angles of the triangular frame C, of which the apex is on the crank of the

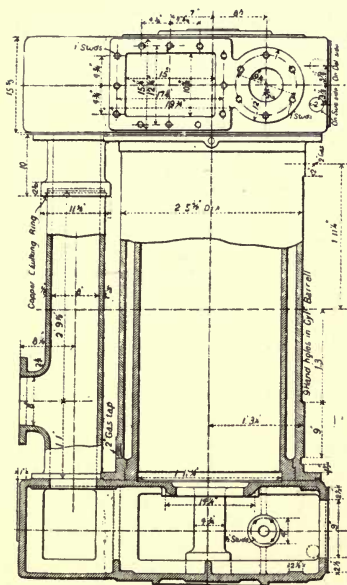

FIG. 188.

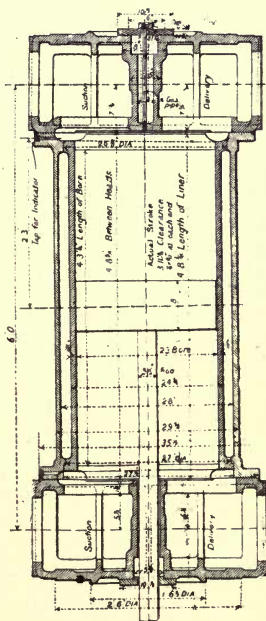

FIG. 189.

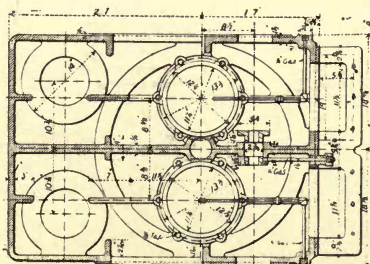

FIG. 190.

flywheel shaft. A pivoted radius link D is connected in the middle of the base of the frame so that the linkage practically

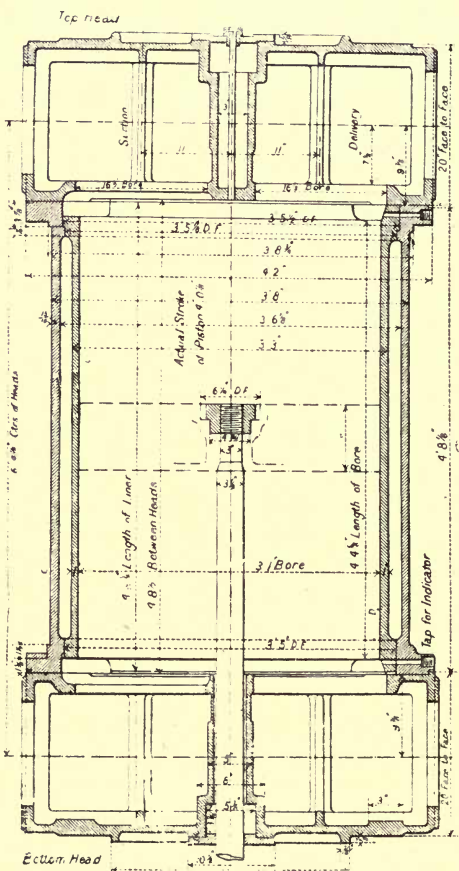

FIG. 191.

connects the piston rods to the crank shaft as if they acted on two cranks at right angles. Figs. 188, 189, and 190

show the high pressure air cylinder, and fig. 191 a sectional elevation of the low. They are connected to the steam cylinders by cast-iron distance pieces, which are in halves, so that they may be removed after the weight of the air cylinder

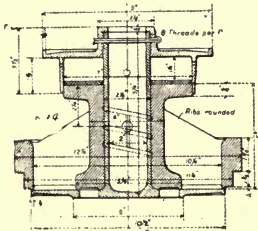

FIG. 192.

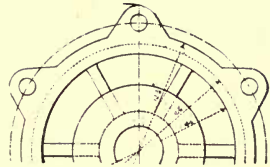

FIG. 193.

has been supported by bottle jacks supplied with the engine. The lower covers can then be removed and the pistons examined. The valves are Riedler's patent, and are mechanically controlled. There is one suction and one delivery valve in each cylinder head, arranged as in fig. 190. The valves for the high pressure cylinder are shown in figs. 192, 193, 194, and 195, the two former giving the suction

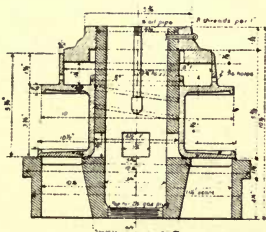

FIG. 194.

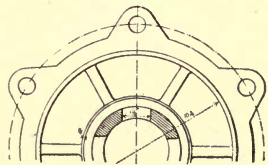

FIG. 195.

valve and the two latter the delivery. The inner diameter of the outer seat of both is  $10\frac{1}{4}$  in., and the outer diameter of the inner seat is  $5\frac{3}{4}$  in. The same dimensions for the low-pressure valves are  $15\frac{1}{4}$  in. and  $9\frac{1}{2}$  in. The latter are very

similar in construction to the former. The lift of the high-pressure valves is  $1\frac{1}{4}$  in. and of the low-pressure  $1\frac{1}{2}$  in. No springs are used, so that extremely little force is required to open the valves, and they are closed as shown in figs. 196

FIG. 196.

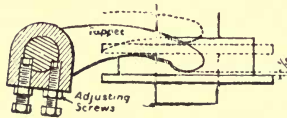
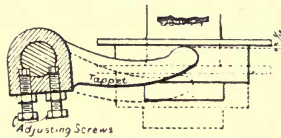

FIG. 197.

and 197; the former showing the tappet acting upon the upper flange of the suction valve, and the latter the same for the delivery. These tappets are oscillated by means of the Corliss gear, fig. 202. The tappets do not control the motion

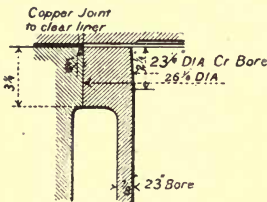

FIG. 198.

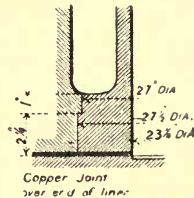

FIG. 199.

while the valve is opening, but shortly before it should close, the tappet brings it very close to its seat, so that when it closes by pressure it does so without shock. Dashpots are fitted at the top of each valve, so that they open without shock. In the delivery valves the air discharged at the



inner seat escapes through the passage formed in the guide. In all these valves care is taken to ensure efficient lubrication. Oil pipes are connected up to the seats, and through these oil is forced under pressure from a special oil pump driven from the engine shaft. The air pistons are of cast iron, fitted with spiral springs, and the air cylinders are water jacketed by means of a liner forced into the barrel and secured in position by copper rings caulked in place, figs. 198, 199, 200, and 201. The outer jacket is provided with a number of hand holes for scraping and cleaning out the water jacket space. The cooler, which is common to both sides, is placed under the floor, and consists of a boiler-plate shell having  $\frac{3}{4}$  in. brass tubes, through which water circulates. Cast-iron pipes connect the air cylinder to the cooler. Each engine is controlled by a Whitmore combined air and speed governor, fig. 204. The two governors are connected

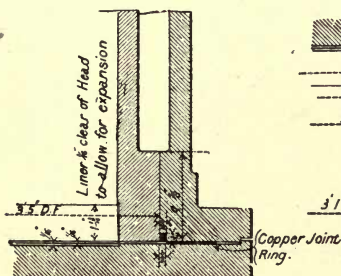

FIG. 200.

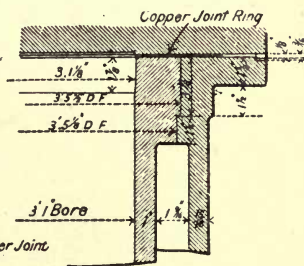

FIG. 201.

together when both engines are running. They are designed to control the engine according to the amount of air required, and to keep the engine running at its minimum speed when no air is needed. Again, should more air be required than the engine can deliver, the governor will prevent it from exceeding its greatest speed. As shown in fig. 202, the governor bar is connected at one end to a ball governor, fig. 204, and at the other end to an air pressure governor, fig. 203. Increase of speed or air pressure raises the free end of the governor bar. This motion alters the position of the

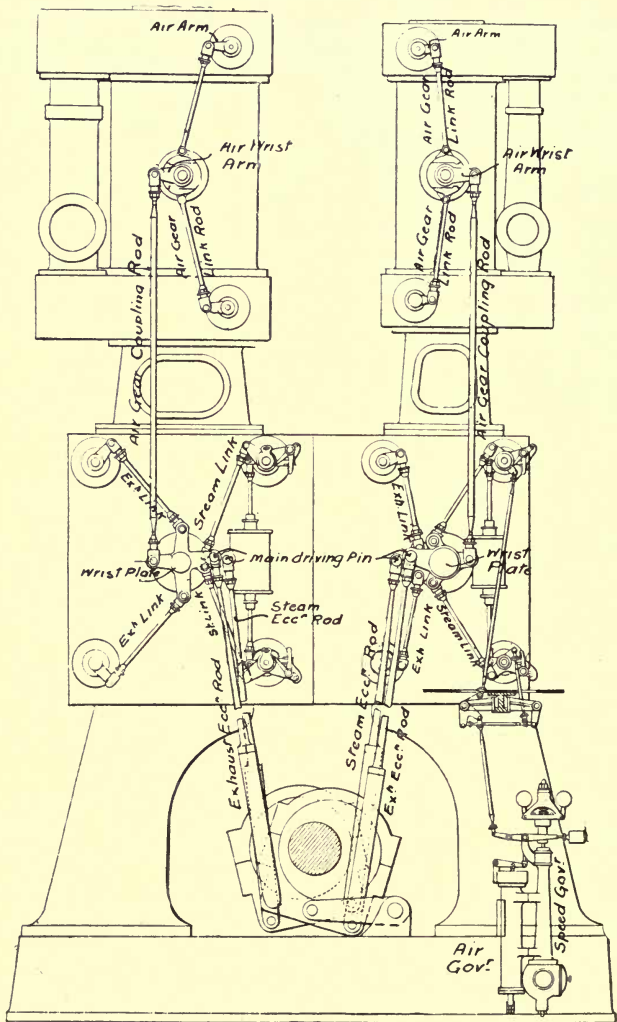

FIG. 202.

trip cams of the Corliss gear, and makes the cut-off earlier. The air governor, fig. 203, consists of a casing G, the interior of which is connected through an open pipe with the air receiver. A piston M is connected at the top by suitable linkwork with the governor bar, and at the bottom with a spring D and also by a link H with the plunger E, which

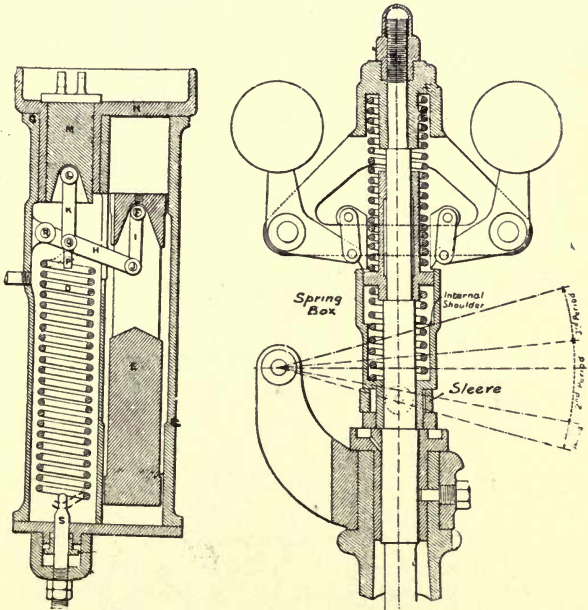

FIG. 203.

FIG. 204.

fits comparatively loosely in its cylinder. As the pressure rises in excess of that required, for which the spring is adjusted, the piston M rises and cuts off steam in the manner already explained. If the pressure were suddenly reduced, *e.g.*, by the bursting of a main, the compressed air which has collected below the plunger E will force it up, and by means of the linkwork I H K, raise M, cutting off steam

exactly as before. The steam valve gear is Reynolds' Corliss gear, with separate eccentrics for the exhaust and steam valves; fig. 202 shows the manner in which motion is taken from these. We have already stated that the I.H.P. developed was 1,050 at 70 revolutions to the minute, their  $a$  being compressed to 60 lb. pressure or 74.7 absolute. The statement that 8,300 cubic feet of free air is compressed per minute implies that the volumetric efficiency is unity. Assuming this, the ideal horse power required to compress to 74.7 or 5.1 atmospheres isothermally is

$$\begin{aligned} \text{H.P.} &= \frac{144 p_2 v_2 \text{ hyp. log } r.}{33,000} \\ &= \frac{14.7 \times 2 \times 37^2 \times 7854 \times 8 \times 70 \text{ hyp. log. } 5.1.}{33000.} \\ &= 870. \end{aligned}$$

The total efficiency

$$= \eta_1 = \frac{870}{1050} = 83 \text{ per cent.}$$

Even if we assume a volumetric efficiency of 90 per cent, which is rather lower than we should expect with such valves and the probable smallness of the clearance, this only reduces to

$$\eta_1 = .9 \times 83 = 74.7,$$

a very good result. With a volumetric efficiency of 95 per cent, this becomes nearly 79 per cent.

49. *Compound Air Compressor with Mechanically-controlled Valves.*\*—This engine is constructed by the Philadelphia Engineering Works, of Merlin Street, Philadelphia. It consists of two air cylinders of 23 in. and 38 in. diameter, whose pistons are driven direct by those of two steam cylinders 22 in. and 40 in. in diameter; the stroke is 48 in., and the boiler pressure 125 lb. The engines are horizontal, and they are arranged as usual, tandem fashion, the two high-pressure cylinders being in line, and also the two low-pressure. The crank shaft carries a flywheel 20 ft. in diameter, weighing 54,000 lb., and the cranks are at right

\* *Engineering*, October 3rd and 31st, 1901.

angles. The valves, both steam and air, are actuated by Corliss gear, but we intend to confine our description to the

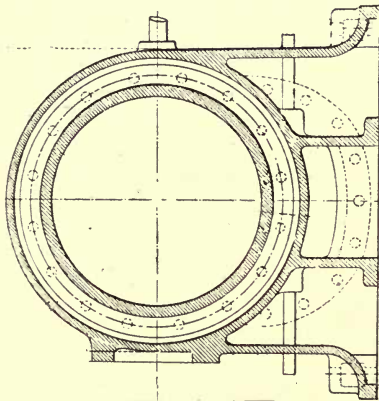

FIG 206

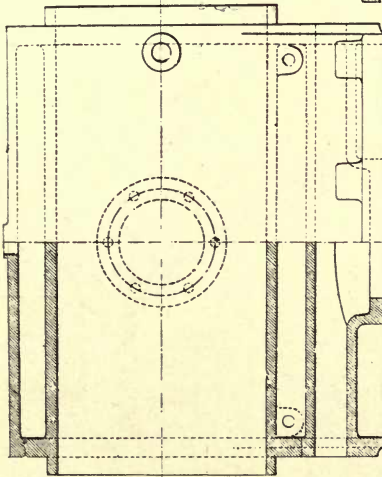

FIG. 205.

air cylinders. The high-pressure cylinder casting is shown in figs. 205 and 206, from which it will be seen that there is

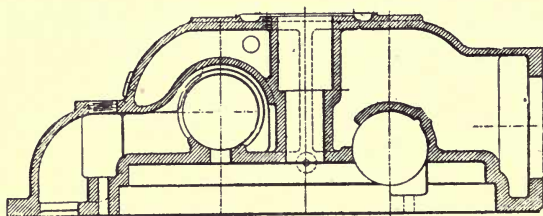

FIG. 209.

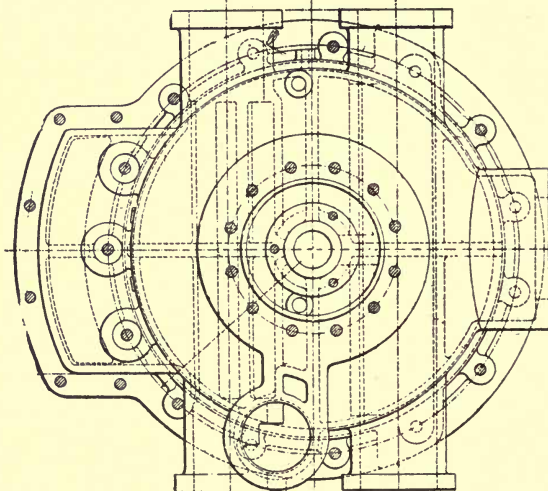

FIG. 208.

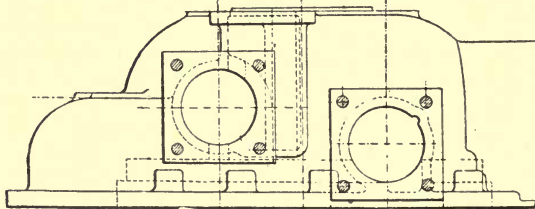

FIG. 207.

a water jacket ; the low-pressure is similar in design. The cover, figs. 207, 208, and 209, shows the valve casings and

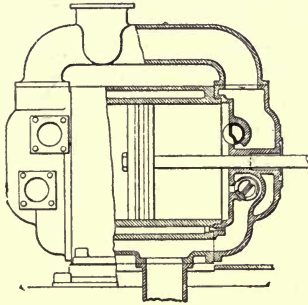

FIG. 210.

arrangement of passages, while fig. 210 is a sectional elevation of the cylinder and valves, the lower being the suction

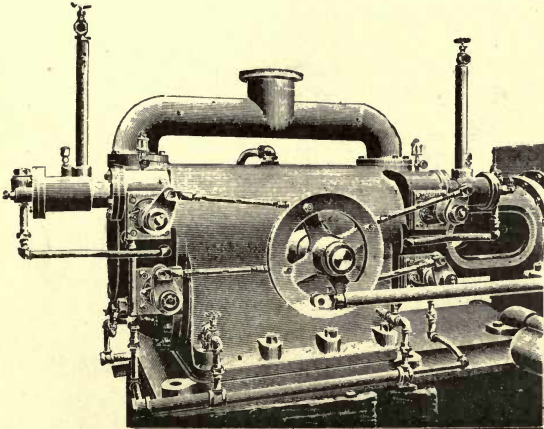

FIG. 211.

and the upper the discharge valve. These are operated by a wrist plate, connecting rods, and levers, fig. 211 ; but while

the motion of the suction valves is entirely dependent upon that of the wrist plate, the motion of the discharge valves is dependent upon the air pressure in the cylinder. The valves are shown in figs. 212 and 213, the first showing the discharge and the latter the suction valves. Figs. 214 and 215 show the manner in which the discharge valve is

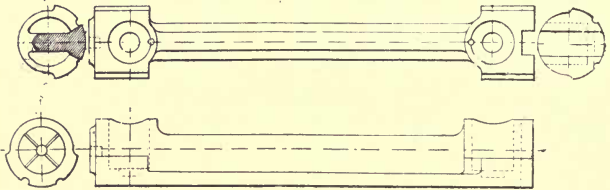

FIG. 212.

opened. In fig. 214 there is a trunk piston, connected by a link to a lever, which moves the valve. The lever is not, however, directly connected to the valve, whose stem can rotate in its boss through a small angle; the trunk piston is connected at the large end to the cylinder, and on the annular surface to the pressure pipes, so that the valve is opened slightly before the pressure in the cylinder reaches

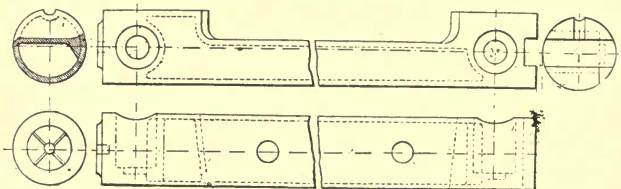

FIG. 213.

that in the pipes. The opening of the valve is shown in fig. 215, the part of the valve over the passage being dotted. Near the end of the stroke the wrist plate forces the valve back again to the closed position, and the valve remains thus because the pressure on the annular side of the trunk piston is greater than that on the side connected to the



cylinder, in which the pressure falls to that of the suction. Figs. 216, 217, and 218 show the air cylinder diagrams, the combined steam diagram, and the combined air diagrams. From these it appears that the air was compressed to

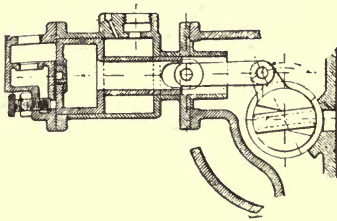

FIG. 214.

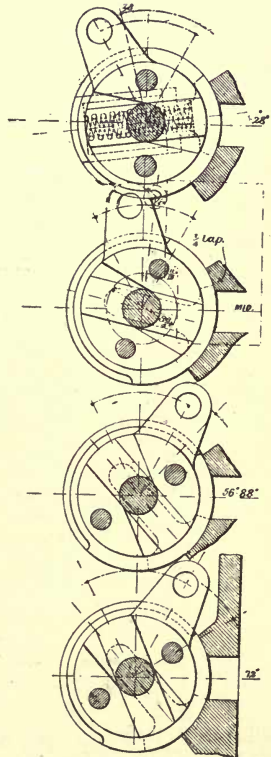

FIG. 215.

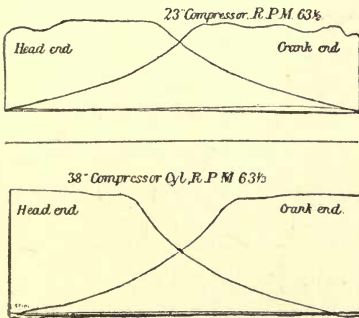

FIG. 216.

111.7 lb. absolute, while the steam pressure was 128 lb. by gauge. The mean load on the two air pistons was 39,643 lb., while that on the steam pistons was 43,316.5 lb., showing a mechanical efficiency of 91.5 per cent. The mean pressures

in the high and low pressure air cylinders were 43·2 lb. and 19·426 lb. per square inch, which, as the piston areas are 410·25 and 1,128·5, gives a mean effective pressure referred to the low-pressure piston of 35·1 lb. The volumetric

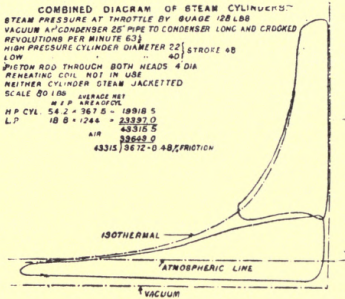

Fig. 217.

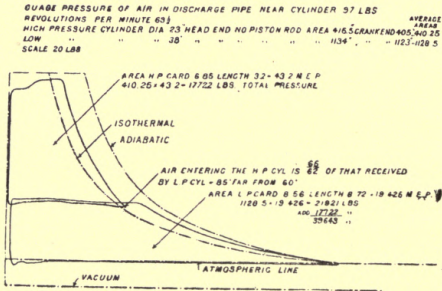

FIG. 218.

efficiency of the low-pressure cylinder appears from fig. 216 to be unity; consequently the ideal mean pressure is

$$p_2 \text{ hyp. log. } \frac{p_1}{p_2} = 14.7 \times 2.3 \log. \frac{111.7}{14.7} = 29.7,$$

so that the air efficiency

$$= \frac{29.7}{35.1} = 84.6 \text{ per cent,}$$

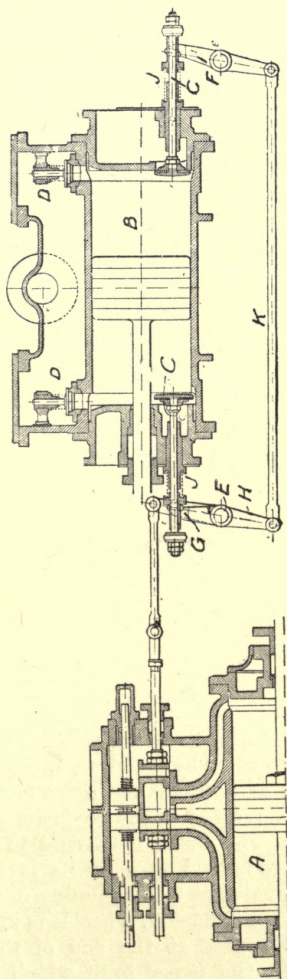

FIG. 219.

and the total efficiency of the engine is

$$91.5 \times .846 = 77.4 \text{ per cent.}$$

The revolutions are  $63\frac{1}{2}$  per minute, so that the piston speed is 508 ft. per minute.

50. *Air Compressor by M. Joseph Francois, Seraing.\** Figs. 219 and 220 show a sectional elevation and end view partly in section of an air compressor for working rock drills. The delivery valves D, D are conical, and are controlled by springs; there are two at each end of the cylinder. The suction valves, of which there is one at each end, are also

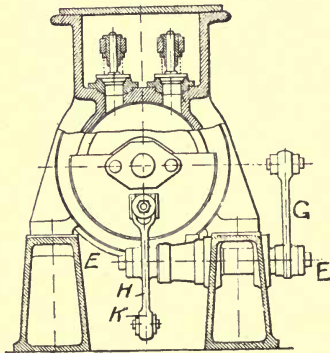

FIG. 220.

conical, with horizontal axis, and are pressed on their seats by springs. They are opened by levers H, I, connected by a link K and pivoted on axes E, F, and these levers are made to oscillate by being connected to the eccentric that drives the distribution valve. The piston is moving to the right, and the left suction valve is held open by its lever. The lever probably opens the valve at the beginning of the stroke, and holds it open until near the end, when it is almost closed by the spring, and of course at the end of the stroke it is closed entirely. In the paper from which we obtain our

\* *Engineering*, September 3rd, 1897.

information this is unfortunately not made clear, and the fact that the eccentric must have advance to drive the steam valves makes it impossible for the levers to open the valve at the beginning and close it at the end of the stroke. The diameter of the steam cylinder is 12·6 in., that of the air cylinder is 11·81 in., the stroke being 19·69, and the highest speed 80 revolutions and the least 5. At 60 revolutions and 71 lb. pressure of air above the atmosphere the horse power is 25, and the weight of air delivered per minute 660 lb. The steam and air cylinders are, of course, in line and the lever G at one side, so that the left half of fig. 219 is a plan, and the right an elevation.

51. *Compound Air Compressor with Mechanically-controlled Valves, constructed by Messrs. Schneider and Co., Creusot.\**—The leading dimensions of this engine, of which four were constructed for the Compagnie Parisienne de l'Air Comprimé, are:—

Diameter of small steam cylinder.....	900 mm.	(35 $\frac{7}{16}$ in.)
Diameter of intermediate cylinder.....	1,400 mm.	(55 $\frac{1}{8}$ in.)
Diameter of large steam cylinder.....	2,000 mm.	(78 $\frac{3}{4}$ in.)
Diameter of low-pressure compressors.	1,100 mm.	(43 $\frac{1}{4}$ in.)
Diameter of high-pressure compressors	780 mm.	(30 $\frac{1}{16}$ in.)
Stroke .....	1,400 mm.	(55 $\frac{1}{8}$ in.)
Diameter of flywheels .....	5,500 mm.	(18 ft.)
Diameter of air pumps .....	800 mm.	(31 $\frac{1}{2}$ in.)
Stroke of air pumps .....	550 mm.	(21 $\frac{5}{8}$ in.)
Diameter of intermediate reservoirs...	1,600 mm.	(63 in.)
Length of intermediate reservoirs.....	9,000 mm.	(29 $\frac{1}{2}$ ft.)

The normal indicated horse power was 2,000 at 60 revolutions; the air pressure, by gauge, 113·8 lb. per square inch; and the boiler pressure 170·7 lb. per square inch.

The engine is shown in figs. 221 to 225. It is vertical, direct-acting, and there are three cranks; the air cylinders are placed above the steam, the high-pressure being in line, and the two low-pressure air cylinders being above the intermediate and low-pressure steam cylinders. The air valves are mechanically controlled, and those of the steam cylinders

\* *Engineering*, September 23rd, 1898.

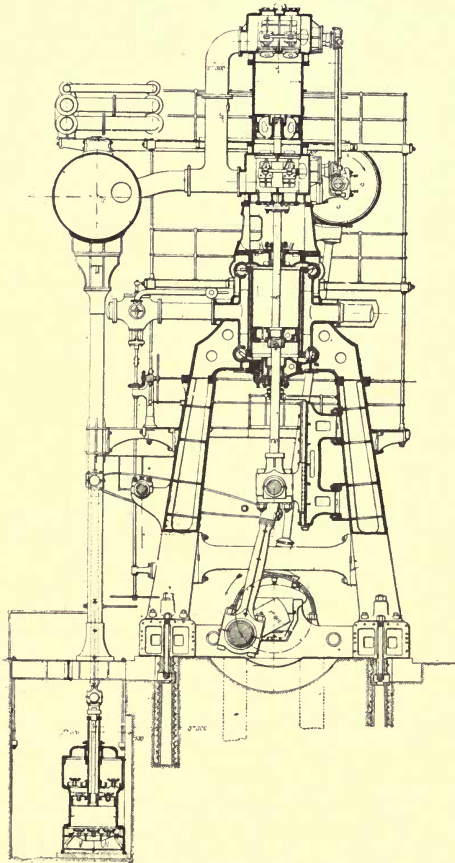
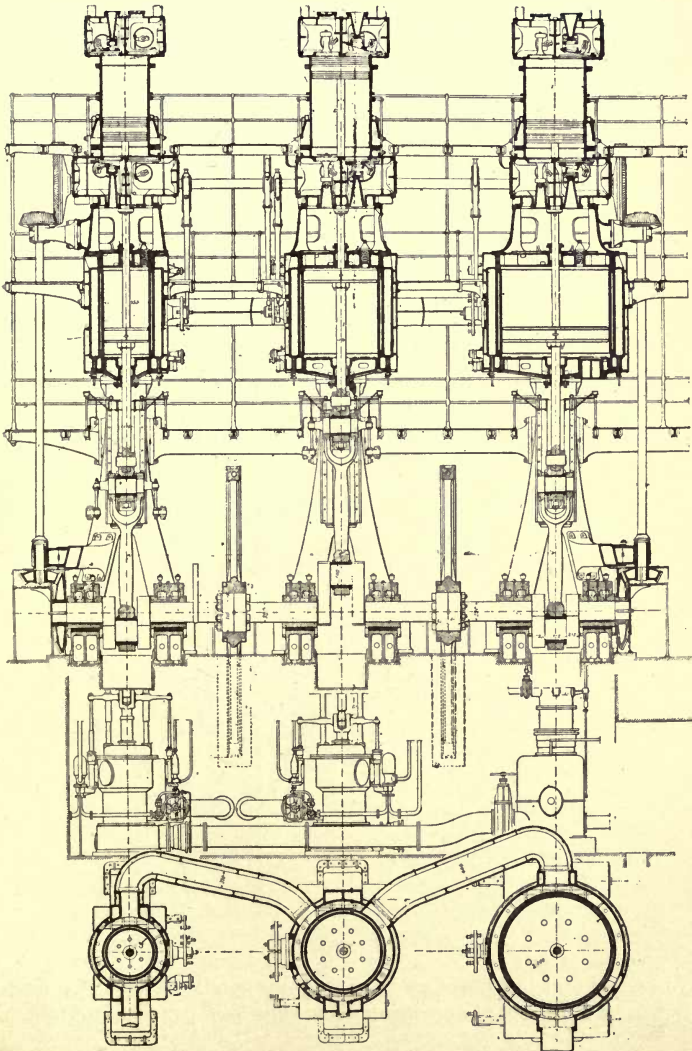

FIG. 221.



Figs. 292 and 293

are of the Corliss type. The engine is controlled by varying the cut-off in the high-pressure cylinder ; that in the inter-

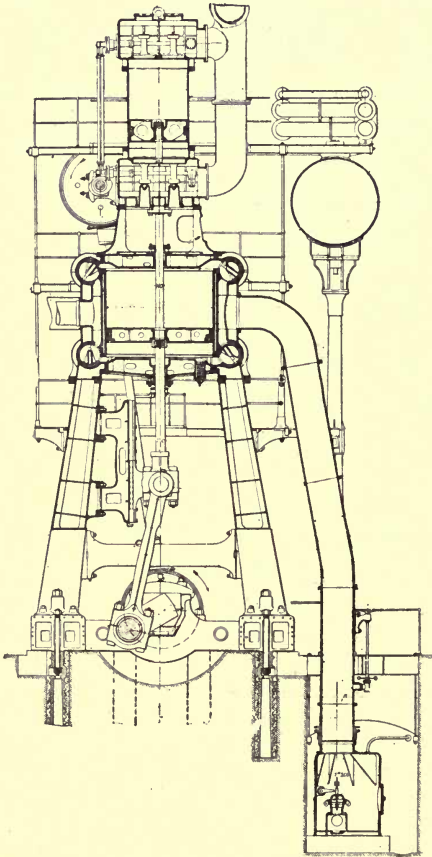

FIG. 224.

mediate and low-pressure is varied by hand. The governor prevents the speed exceeding 72 revolutions per minute, and



to prevent the air pressure rising too high, a special governor slackens the speed when the pressure passes 113·8 lb. per square inch (8 kilogrammes per square cm.). Both governors act on the same expansion gear. In fig. 222 it will be seen that there is a bevel wheel at each end of the main shaft driving two vertical shafts, which, by means of a pair of bevel

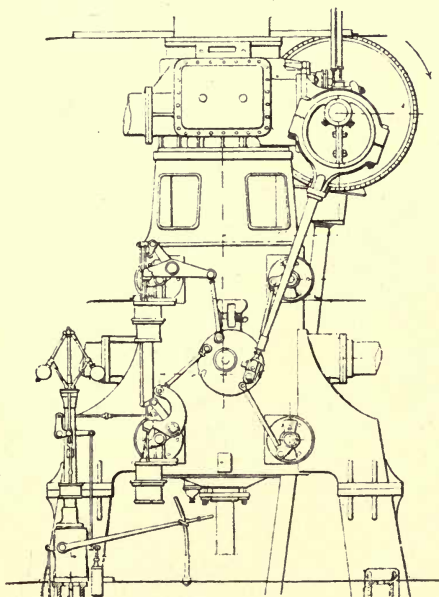

FIG. 225.

wheels at their upper ends, drive a horizontal shaft, upon which are keyed eccentrics whose rods drive the wrist plates of the steam Corliss gear, fig. 225. The air valves are operated by cams upon this shaft, figs. 221 and 223, the valves themselves being of brass with indiarubber flaps, as shown in figs. 226, 227, and 228, the first, fig. 226, being a suction valve in half plan and section; fig. 228 a section through a delivery valve, and fig. 227 a plan. The mechanical control in no way affects the opening of the

valve, but near the end of the stroke brings it close to its seat, so that it closes without shock when a reversal of pressure takes place. The condensers, air, feed, and drain pumps are below the engine room floor level, in a space 12 ft. deep, well lighted, and free of access. There are two single-acting air pumps, each a little more than one-sixteenth of the volume of the low-pressure cylinder, worked by cast-iron levers driven by the small and intermediate piston rods.

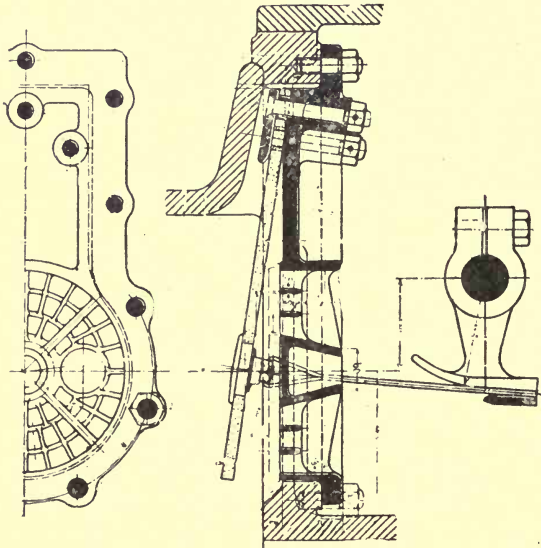

FIG. 226.

Air is drawn in through the louvres on the roof, which are in communication, through the box girders and hollow pillars that support them, with the two low-pressure compressing cylinders. Special pumps with valves worked mechanically on the Riedler system, and independent of the main engines, deliver the water necessary for cooling the air in the compressors and intermediate reservoirs.

Several efficiency and coal consumption trials were made with these engines, in one of which the indicated horse power was 1,996.5 at 59.635 revolutions, with a boiler pressure of 157.2 lb., a pressure in the high-pressure valve chest of 146.4 lb., and an air pressure of 102.4 lb. per square inch. If the volumetric efficiency of the air cylinders had been given, this would have enabled us to calculate the total

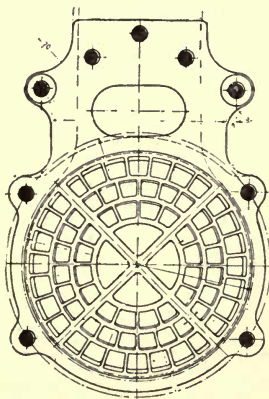

FIG. 227.

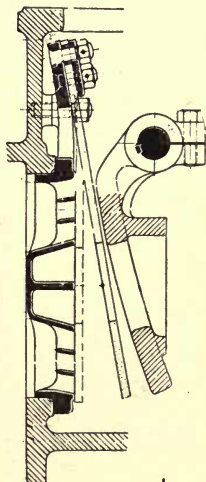

FIG. 228.

efficiency of the engine. The clearances are undoubtedly small, and with mechanically-controlled valves the admission line is very little below the atmospheric, so that the volumetric efficiency cannot be much below unity. Taking this value, we have the ideal horse power necessary to compress to 102.4 lb. above the atmosphere, or 117.1 absolute is

$$\begin{aligned} \text{Air horse power} &= \frac{144 p_2 v_2 \text{ hyp. log. } r}{33000} \\ &= \frac{14.7 \times 2 \times .7854 \times (43\frac{1}{4})^2 \times 55\frac{1}{8} \times 59.635 \times 2 \times 2.3 \text{ log. } 7.975}{12 \times 33000.} \\ &= 1485 \text{ at } 59.635 \text{ revolutions.} \end{aligned}$$

So that the total efficiency is

$$\eta_1 = \frac{1485}{1996.5} = 74.4 \text{ per cent.}$$

The volumetric efficiency is certainly not less than 95 per cent, which would give a total efficiency of 71 per cent nearly.

52. *Air Compressor, with Equalisation of Pressure at the End of the Stroke.\**—This compressor is constructed by Messrs. Richardson, Westgarth, and Co., of Middlesbrough, and is principally of interest as its valves are constructed to produce equalisation of pressure at the end of the stroke, and so increase the volumetric efficiency. The slide valve resembles very closely the distribution valve of Meyer's expansion gear. It carries on its back another valve, which, however, moves with it, and is held down by a spring, rising when the pressure in the cylinder is slightly in excess of

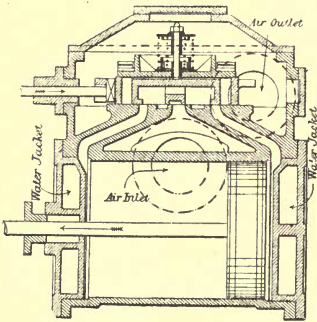

FIG. 229.

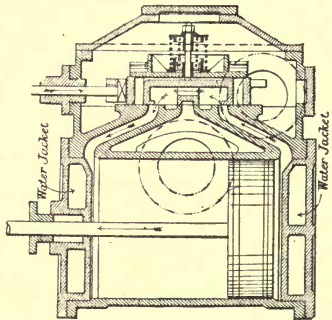

FIG. 230.

that in the valve chest. The air is admitted at the port, which in a steam engine is usually the exhaust, and is discharged through the two vertical passages at the end of the valve. Fig. 231 shows admission taking place on the right of the piston; the air is passing through the middle port, and over and under the small central valve within the

\* From *Engineering*, September 4th, 1903.

larger valve. Discharge is taking place through the left-hand vertical passage in the slide valve, and the upper valve is raised. Fig. 229 shows the piston close to the end of its

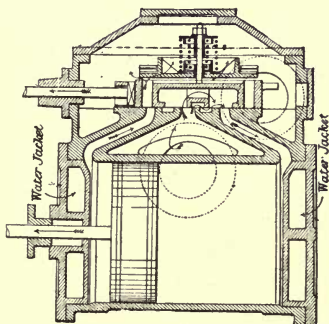

FIG. 231.

stroke. Discharge has ceased, as the right-hand vertical passage in the slide valve is now closed, and equalisation of pressure is just about to commence, while admission on the

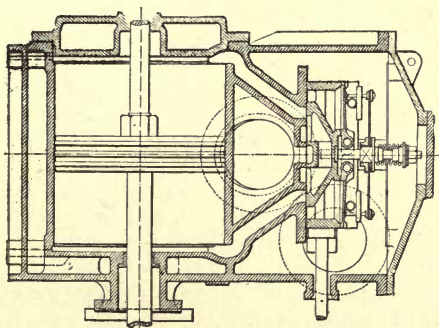

FIG. 232.

left of the piston is just at an end. Fig. 230 shows equalisation taking place, admission and discharge being both closed. This construction provides a large equalisation

passage, which cannot become choked. Fig. 232 shows a vertical cylinder and equalisation valve in which two flap valves are fitted.

53. *Messrs. Hughes and Lancaster's Patent Glandless Corliss Valves.*—Fig. 233 is a side elevation of the compressing cylinder, and shows the manner in which the valves are driven from the eccentric. The end of the eccentric rod is on the left, and a coupling rod connects the two valve cranks, of which one, T, is seen on the right. There is only one valve at each end, V, fig. 235. The piston is moving to the right, and both valves are turning counter-clockwise; the left is admitting air from the suction passage A through

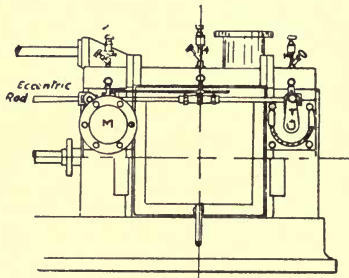

FIG. 233.

the cylinder port G, and the right is connecting the cylinder to the space D in the valve, but discharge has not yet commenced, as the non-return valve H, fig. 234, closes the passage to the discharge F. The piston is, in fact, in such a position that the air compressed in the clearance has expanded to atmospheric pressure, and as the delivery lap is equal to the admission lap, the valves open simultaneously. The valve diagram has already been discussed in Section 13, fig. 13, for the motion of the valves V, V is approximately harmonic. In that figure *cn*, *cr* are the admission and delivery laps; admission commences when the crank is at *cg* and ends when it is on the dead centre *cb*, the eccentric following the crank in the direction of the clock, the angle between them being *acd*. On the next stroke the valve opens the delivery passage D when the crank reaches *ct*, which is *gc* produced,

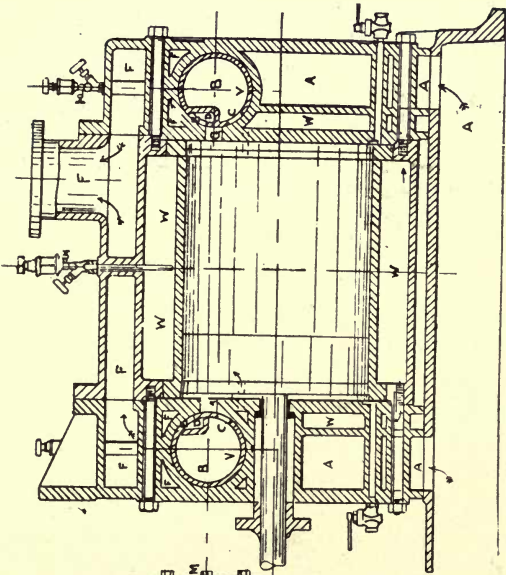

FIG. 235.

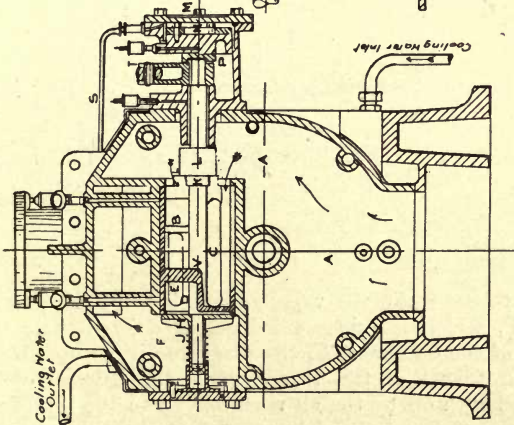

FIG. 234.

so that admission and the opening of the delivery passage occur simultaneously. The delivery passage is closed at the dead centre  $ca$ , and the valve H returns to its seat without shock under the force of the spiral spring, the pressure on both sides of it being the same. I is a dashpot for the valve; H and J are passages allowing the air to escape from it. The valve lever T is shown in section on the right of fig. 234. K is the intermediate piece of an Oldham coupling, and L is the driving fork. As the air pressure produces a

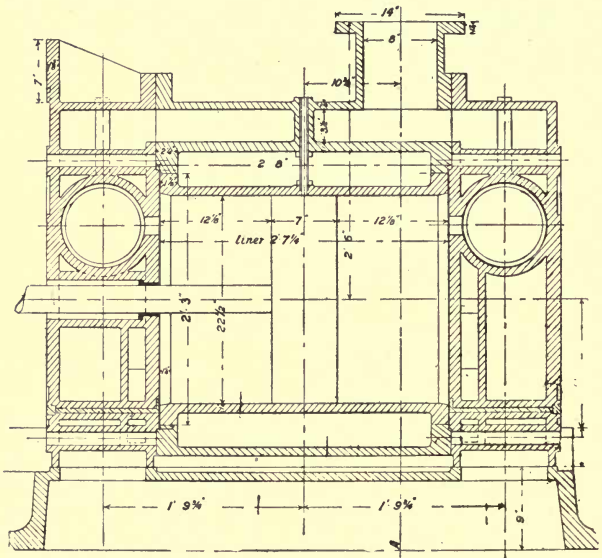

FIG. 236.

thrust to the right, the valve spindle is fitted with a thrust-piece P, which is lubricated through a small hole in the centre of the oil piston N, the pressure upon which balances the end thrust of the valve. M is the balance cylinder, supplied with oil by the oil reservoir R, to the top of which air pressure is admitted by the pipe S. The advantages claimed for these valves are: (1) That the valve is opened and



closed mechanically for suction, which avoids wire drawing and prevents any leakage past the valve at the end of the stroke. (2) The delivery valve is shut mechanically, also preventing leakage, and it is opened automatically. (3) The

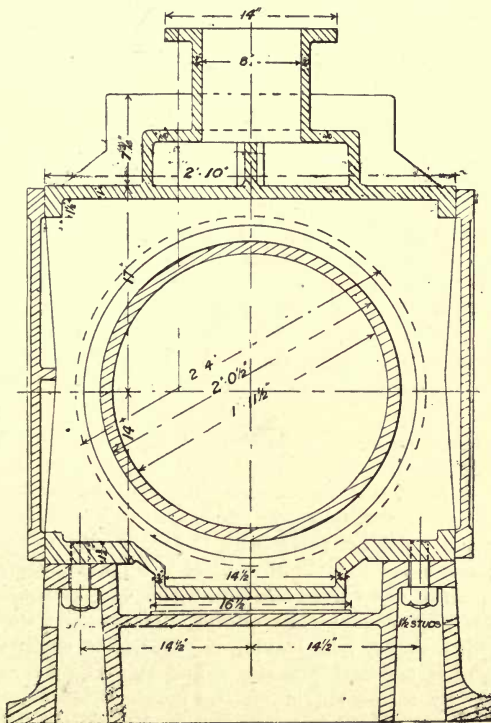

FIG. 237.

clearance is small, being not more than 1 per cent of the cylinder volume in large sizes, so that a high volumetric efficiency is obtained. The air imprisoned in the Corliss valve passage D does not affect the volumetric efficiency, as it is only let back into the cylinder after the compression

stroke has commenced. (4) There is no jar or knock in valves, and the running is extremely quiet at all speeds. Very high speeds are obtainable; *e.g.*, 450 revolutions with an 8 in. stroke, or 600 ft. of piston speed per minute, which is very high for such a short stroke. (5) The small number of valves makes their upkeep small, and there is a smaller number of moving parts to get out of order. (6) There is no gland to pack, and the valve is in almost perfect equilibrium, and the lubrication perfect. The Oldham coupling allows the valves to follow up their wear with certainty. (7) Both body and about three-quarters of the end covers are water jacketed in the spaces W W, and the air at inflow does not come in contact with any heated surface till it reaches the inlet valve. (8) Should the valve go wrong, there is only one cover, which is held down by four studs, to remove. The engine can be stopped, the valve taken out, examined, replaced, and the engine re-started on the largest compressors in less than five minutes. Figs. 236 and 237 are sectional elevations, showing details of construction of a 22½ in. diameter and 24 in. stroke air cylinder.

54. *Air Compressor Constructed by the Worthington Pump Company.*—Fig. 238 is a sectional elevation of the compressing cylinder, the distinguishing feature of which is the valve gear, which combines in a very ingenious manner the positive action, noiseless operation, and durability of the mechanically moved valve with the elasticity of the poppet valve; the noise and rapid wear of the poppet valve, due to the impact of the valves closing at the end of the stroke, is eliminated by mechanically closing the passages underneath the poppet valve, and leaving a cushion of compressed air upon which the latter seats. The two Corliss valves are operated by an eccentric on the crank shaft in a manner very similar to that shown in section 50. The action of the valve gear is clearly shown in figs. 239, 240, 241, which give the position of the valve at various points of the stroke. At the beginning of the suction stroke of the piston, indicated by position 1, fig. 241, the mechanical valve A, fig. 239, is just about to close port B, the discharge edge of A being in line with the upper edge of port B, and the valve moving in the direction shown by arrow C. After

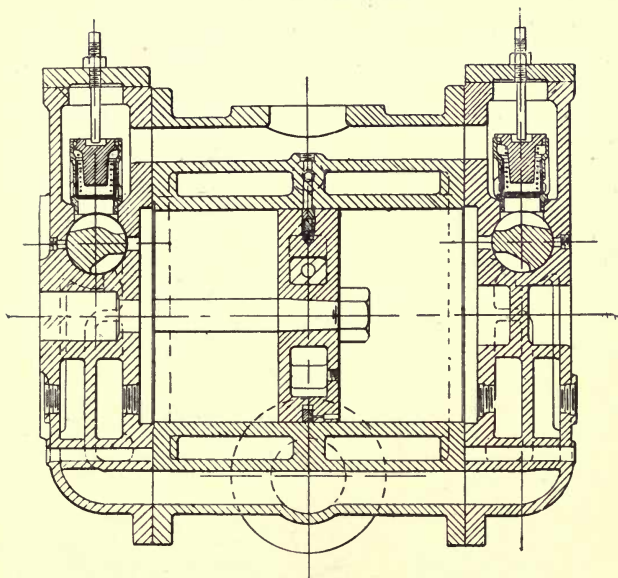

FIG. 238.

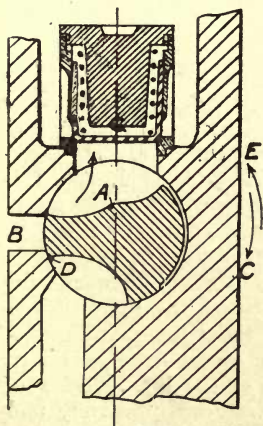

FIG. 239.

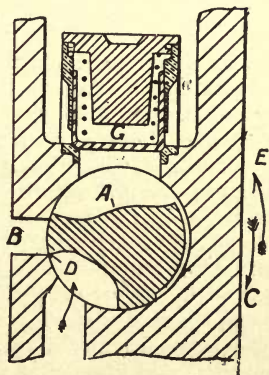

FIG. 240.

the piston advances a short distance, the valve has reached the position shown in fig. 240, in which the inlet edge of the valve D is just coming line and line with the lower edge of port B. The valve continues to move in the direction of the arrow C until about mid-stroke, when it reverses to that shown by the arrow E, bringing the valve back to the position shown in fig. 240, at the end of the stroke corresponding to position 3 on the ideal card, fig. 241. The compression stroke now commences, the valve still moving in the direction of the arrow E. After the mechanical valve opens, the poppet valves G, fig. 239, which have had the entire return stroke in which to seat, prevent the flow of air back from the discharge passages to the cylinder, and

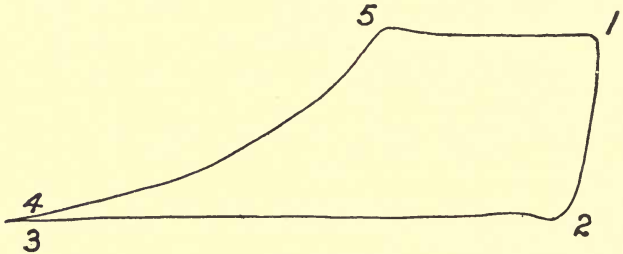

FIG. 241.

remain closed until position 5 in fig. 241 is reached, when the pressure inside the cylinder slightly exceeds that in the discharge passages. The poppet valves G thereupon open, and remain open, until position 1, fig. 241, is reached, at which point the valve A, which in the meantime has changed its direction to that shown by arrow C, has resumed the position shown in fig. 239, thus leaving a volume of compressed air in the space between the mechanical and poppet valve, permitting the light springs back of the poppet valves G to seat them easily and gently during the return stroke. Thus the three fixed points in the compression cycle, viz., opening of the inlet, closing of the inlet, and closing of the discharge, are positively and mechanically controlled; the opening of the discharge, the

only variable point in the cycle, is controlled by the automatic poppet valves, which are relieved, however, of the necessity for quick closing, and are consequently free from

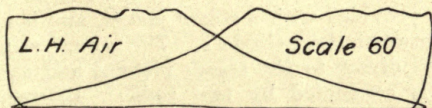
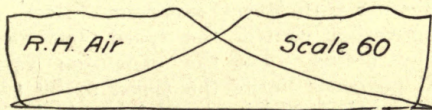
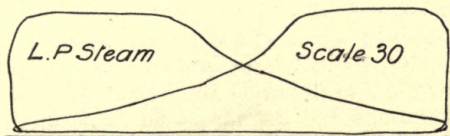
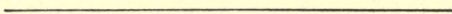
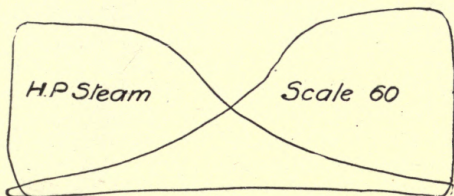

FIG. 212.—Complete cards from  $\frac{1}{20}$  in.  $\times$  14 in.  $\times$  18 in. Cincinnati Gear Compressor. Steam pressure, 85 lb. per square inch; air pressure, 30 lb. per square inch; 150 revolutions per minute.

the objectionable feature of noise and rapid wear. Two of these compressors were exhibited working at the St. Louis Exhibition. Indicator diagrams are shown in fig. 242.

55. *Cross-compound Two-stage Compressor constructed by the Breitfeld Daněk Engineering Company for the Krimich shaft of the St. Pankraz Mine in Nürschau.*—Compressed air has been used for many years in this mine for driving machinery underground, and when an increase of power was needed, it was decided to replace the existing small compressors by a large compound two-stage machine. This was constructed by the Breitfeld Daněk Engineering Company, of Prague-Karolinenthal, and since the 9th of March, 1903, has worked without a stop. At present it drives six hauling engines, ten piston pumps, three coal cutters, and several ventilators on Körting's system. The high-pressure steam cylinder has a diameter of 675 mm. (26·6 in.), the low-pressure 950 mm. (37·4 in.), that of the small air cylinder is 550 mm. (21·7 in.), and of the large 875 mm. (34·5 in.); the stroke is 900 mm. (35·5 in.). With a boiler pressure by gauge of  $5\frac{1}{2}$  atmospheres (81 lb.) and the same air pressure, the engine runs at 60 revolutions and discharges 60 cubic metres (2,110 cubic feet) of free air per minute, and can, if necessary, discharge 80 cubic metres (2,820 cubic feet). The high-pressure cylinder is fitted with Rider expansion gear, and the low-pressure with Meyer expansion valves. Not only does the governor control the speed, but also the air pressure by acting upon the expansion valve. The centrifugal governor limits the speed to 80 turns. The air pump is vertical, and is placed beneath the crankshaft at the right end. It is driven by a connecting link from the end of the crank, and a lever; its diameter is 600 mm. (23·6 in.), and its stroke 250 mm. (9·84 in.). The steam receiver is provided with a steam jacket, and is also underground, between the cylinders. The compressing pistons are coupled direct to the steam pistons, and each pair of cylinders is connected by two rods. Between the air cylinders, parallel to them and under the floor, is the intermediate air cooler. The effective length of this is 3,015 mm. (119 in.), and its diameter 800 mm. (31·5 in.).

It contains 156 drawn-brass tubes of 32 mm. (1.26 in.) outer and 29 mm. (1.14 in.) inner diameter, which are divided into groups by plates in order to increase their cooling action. An inclined plunger pump driven by an eccentric on the main shaft supplies water to a reservoir, from which it flows through these tubes. The plunger diameter and stroke are 175 mm. and 180 mm. (6.9 in. and 7.1 in.). The tubes have an effective length of 3,000 mm. (118 in.), so that their external cooling surface is 47 square metres (505 square feet). The intermediate cooler has a volume of 1.508 cubic metres (53 cubic feet); the tubes occupy 0.374 cubic metres (13.15 cubic feet), so that the cooler contains 1.134 cubic metres (39.85 cubic feet). The volume of the small air cylinder is 0.21 cubic metre (7.43 cubic feet), and that of the large cylinder 0.54 cubic metre (19 cubic feet); so that the ratio of the three volumes of cooler, large cylinder, and small cylinder is as 5.40 : 2.57 : 1. The tubes have a total section of 0.109 square metres (1.17 square feet), while the effective section of the cooler is 0.38 square metre (4.08 square feet), the ratio being 1 : 3.49. The latter section bears to that of the two compressing cylinders the ratio 1 : 1.56 : 0.61. Each cubic metre of air has a cooling surface of 41.44 square metres, or 1 cubic foot to 12.05 square feet. The air, before being drawn into the large cylinder, passes through a Möller filter in the roof, and a manometer shows whether this filter requires cleaning or not. At each end of a compression cylinder there is a suction and a delivery valve. In figs. 243 to 246 are shown mechanically-controlled suction and delivery valves similar to, although not the same size as, those used in this engine. Figs. 243 and 245 are sectional elevation and plan of the delivery valve and figs. 244 and 246 of the suction. The valves are operated from the tail end of the expansion valve spindle by levers outside and inside the valve chest, the latter being fitted with adjustable springs. These offer no opposition to the opening of the valves, which is therefore effected by a difference of pressure sufficient to overcome friction and inertia, an extremely small quantity, the valves being very light; but shortly before the end of the stroke the valves

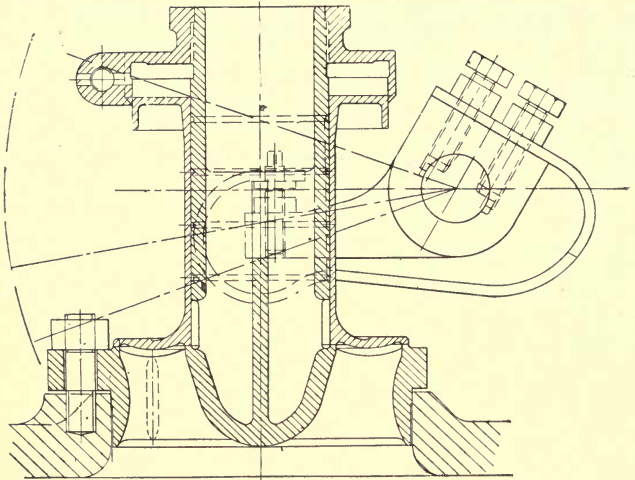

FIG. 243.

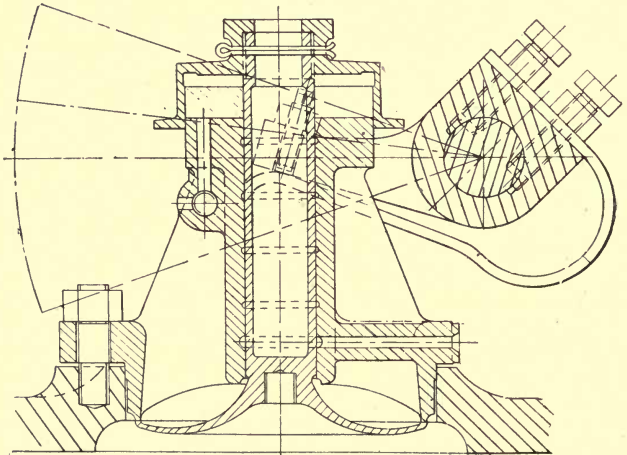

FIG. 244.



are compelled to approach their seats very closely, and finally close without shock, owing to the difference of pressure. Thus one valve with a large lift can replace a number of small ones. At the normal speed of 60 revolutions the valves work without the least noise, and it is only at 70 revolutions that their working can be heard, and then only slightly; a speed of 85 revolutions is admissible. The valves themselves are of forged steel, and carry pistons at the ends of their hollow guide spindles, which work in cylinders so as to limit the strokes of the

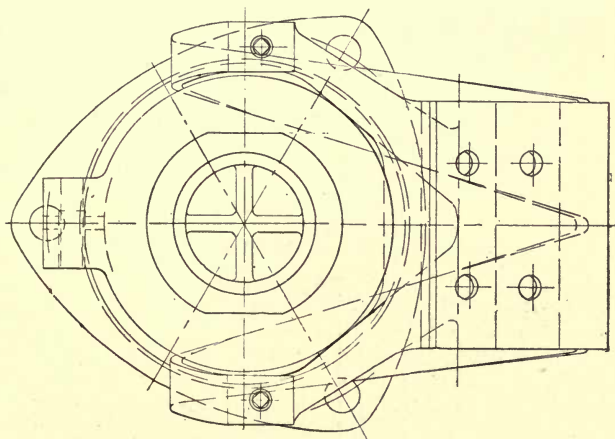

FIG. 245.

valves and form air cushions, the force exerted by which can be adjusted by screws, to the left of the air-cushion cylinder in figs. 243, and to the left and below it in fig. 244. These screws, of course, control the rapidity with which the air can escape from the cylinder. The seat and valve guides are in one piece, and are of cast iron, while the air-cushion cylinder is of bronze. The air-cushion screws can be adjusted for noiseless working from the outside of the casing. Both suction and delivery valves of the large cylinder and the delivery valve of the small cylinder have each two seats 4 mm. broad, but the suction valve of the

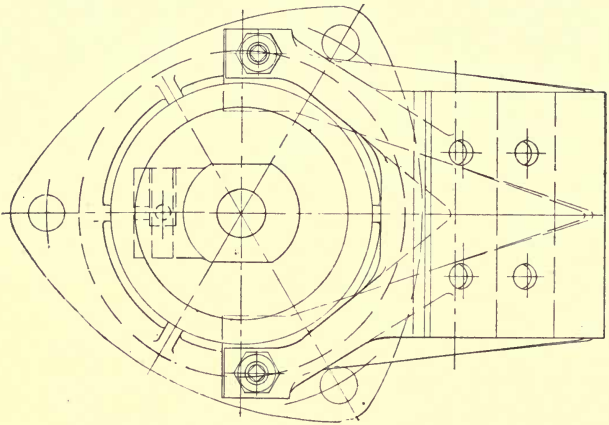

FIG. 246.

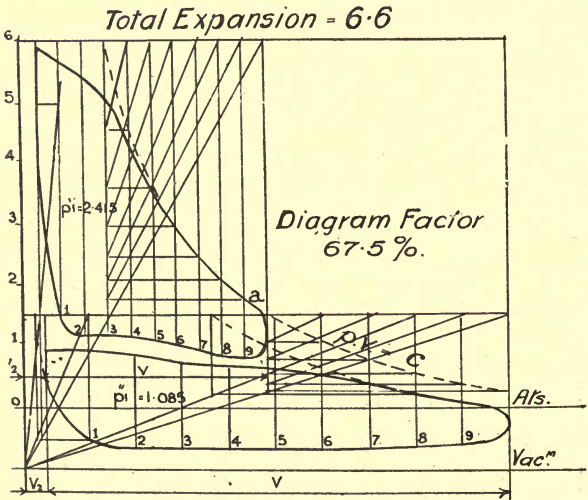

FIG. 247

latter has only one of the same breadth. In the suction valve of the small cylinder the air passage is 154.48 square centimetres (24 square inches), that of the delivery valve is 151 square centimetres (23.4 square inches). In the suction valve of the large cylinder it is 397 square centimetres (62.5 square inches), and in the delivery valve 393 square centimetres (62 square inches). The effective piston area of the small piston is 2,312 square centimetres (358 square inches), while that of the large one is 5,950 square centimetres (922 square inches). The piston areas are therefore about fifteen times those of the valve passages. As the mean piston speed at 60 revolutions per minute is 1.8 metres per second, it follows that the mean velocity of the air through the valves is 27 metres per second (88.5 ft.). Both compressing cylinders have water jackets, in which water circulates. The pistons have three cast-iron rings. The piston rods are of Siemens-Martin steel; as also the pins and bolts of the valve gear, which are hardened. The steam is superheated to 250 deg. Cen. (482 deg. Fah.). Shoda and Hering superheaters are used. Combined steam and air diagrams are given in figs. 247 and 248. The following is a list of air compressors constructed by the Breitfeld Danék Engineering Company:—

SINGLE CYLINDER—SINGLE STAGE.

Stroke in mm.....	250	300	400	500	600	700	800	900		
Stroke in ins.....	9.85	11.82	15.75	19.7	23.65	27.6	31.5	35.5		
Diameter of steam and air cylinders.	{ mm..	240	300	380	475	500	575	625	675	
	{ ins..	9.45	11.82	14.95	19.15	19.7	22.65	24.65	26.6	
Steam press. in atmosphere.	5-6	5-6	5-6	5-6	5-6	5-5	6-8	6-8		
Air pressure in atmosphere.	4	4	4	4	4	4	4-5	4-5		
Revolutions per minute..	{	125	125	100	90	90	80	70	60	
	{	to	to	to	to	to	to	to	to	
		150	150	125	100	100	90	80	70	
Air per minute..	{ c. metres..	2.5-3	5-6	8-10	14-16	19-21	25-28	30-33	34-40	
	{ c. ft....	{	88	176	251	492	668	880	1055	1195
		{	to	to	to	to	to	to	to	
			105.5	211	352	572	739	984	1160	1410

## COMPOUND—TWO STAGE.

Stroke in .....	{ mm..	700	800	900
	{ ins. ..	27·6	31·5	35·5
Diameter of H.P. steam cylinder..	{ mm..	500	575	675
	{ ins. ..	..	..	..
Diameter of L.P. steam cylinder..	{ mm..	735	840	950
	{ ins. ..	..	..	..
Diameter of small air cylinder....	{ mm..	430	500	550
	{ ins. ..	..	..	..
Diameter of large air cylinder ....	{ mm..	675	775	875
	{ ins. ..	..	..	..
Steam pressure by gauge in atmosphere..		6—8	6—8	6—8
Air pressure by gauge in atmosphere ....		5—7	5—7	5—7
Revolutions per minute .....		70—80	60—70	60—70
Air per minute .....	{ c. metres.	33—38	43—50	60—70
	{ c. ft.....	1160—1335	1510—1760	2110—2460

A test made June 20th, 1903, gave the following results:—

Revolutions per minute, 68.

Mean steam pressure by gauge, 5·6 atmospheres (82·3 lb.).

Mean air pressure by gauge, 5·8 atmospheres (85·2 lb.).

Mean vacuum, 61·4 centimetres (24·2 in.).

Injection water, 28 deg. Cen. (82·4 deg. Fah.).

Indicated steam horse power, 437·5.

Indicated compressor horse power, 386·8.

Mechanical efficiency, 88 per cent.

Volumetric efficiency, 97 per cent.

Total efficiency, 71 per cent.

Volume of free air compressed per steam I.H.P. hour,  
9·376 cubic metres (330 cubic feet.).

Steam per I.H.P. hour, 7·8 kilogrammes (17·15 lb.).

Weight of steam per cubic metre of free air compressed,  
0·799 kilogrammes.

Cubic feet of free air compressed per pound of steam,  
20 cubic feet.

Temperature of atmosphere, 27 to 29 deg. Cen. (80.6 to  
84.4 deg. Fah.).

Temperature of air entering intermediate cooler, 115 to  
136 deg. Cen. (239 to 277 deg. Fah.).

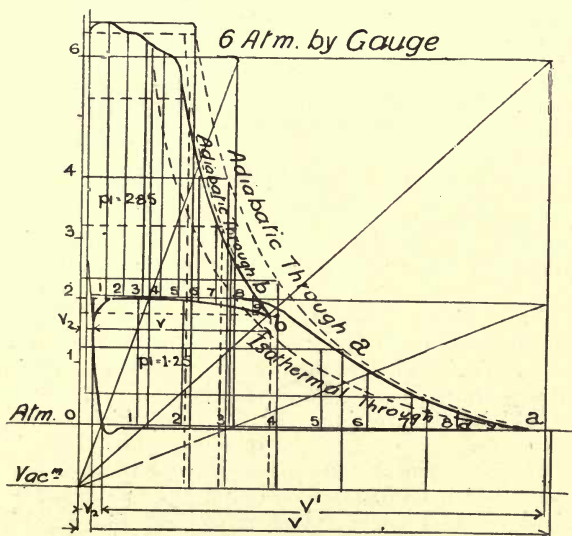

FIG. 248.

Temperature of air leaving intermediate cooler, 50 to  
57 deg. Cen. (122 to 134.5 deg. Fah.).

Temperature of air after compression, 124 to 146 deg.  
Cen. (255 to 295 deg. Fah.).

At the St. Pankraz Mine, it may be mentioned, the compressed air is heated by petroleum burners before its use in the engines that it drives, and experiments are being made for the introduction of these burners into the pressure pipes themselves. It is an unfortunate fact that

the total efficiency of compressors and motors is only about 40 to 50 per cent.

56. *Castellain Air Compressor constructed by the Breitfeld Dânek Engineering Co., of Prague-Karolinenthal.*—Figs. 249 and 250 show in plan and elevation a belt-driven Castellian compressor. Fig. 251 is also a section through cylinders and receiver, showing the Corliss and self-acting valves. Its working is as follows: Atmospheric air enters the left-hand side of the large cylinder, being admitted by the Corliss valve to the left, and slightly below it. This valve is driven by an eccentric on the shaft, fig. 249, which also drives the Corliss valve of the high-pressure cylinder. When the piston moves from right to left the air on the left side is compressed until its pressure is sufficient to open the self-acting valve that is placed below the Corliss valve, and air flows into the receiver. On the other side of the piston there is at first expansion from the receiver, and after the discharge from the other side commences there is expansion from the air on the other side of the piston and from the receiver, assuming that the rod or trunk on the right is less than that on the left. If it is the same size there is no change of pressure, and if greater there will be compression. In fig. 253, which shows the indicator diagram on the right side of the piston, the lower part of the curve shows expansion, and the upper compression, which takes place on the stroke to the left in the receiver, high-pressure cylinder, and on the right-hand side of the piston. This is also the suction stroke of the high-pressure piston, to which air is admitted by the Corliss valve above its left end. The discharge valve is self-acting, and is just above the Corliss valve. The Corliss valves are arranged to close at the end of the stroke, so that the self-acting valves seat themselves upon an air cushion, and therefore quietly and without shock. Fig. 252 is the high-pressure diagram, with mean effective pressure 3·17 atmospheres; fig. 253 has a mean effective pressure of 0·18 atmospheres, and fig. 254, the low-pressure diagram, 1·133 atmospheres. These were taken on the 16th of February, 1904; the speed was 160 revolutions, the two cylinders 200 mm. and 400 mm. diameter (7·89 in. and 15·78 in.),

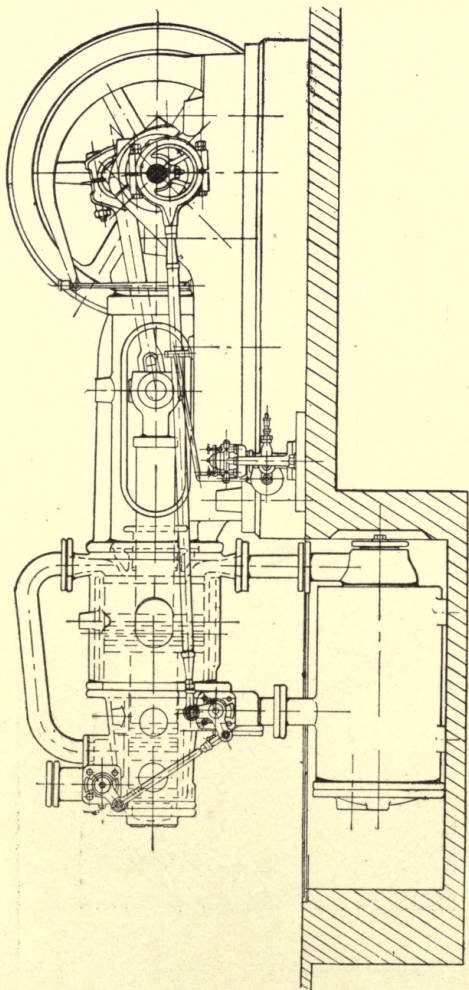

FIG. 249.

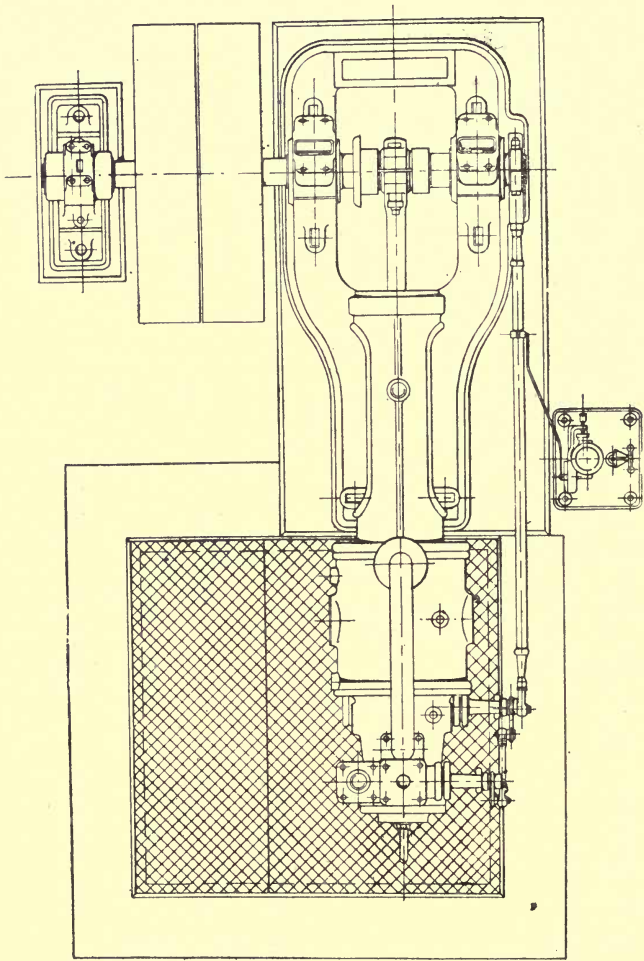

FIG. 250.



with 300 mm. stroke (11·8 in.), and a trunk piston rod of 150 mm. (5·9 in.). If  $p_e$  is the mean effective pressure referred to the low-pressure piston in atmospheres,

$$p_e = 1.133 + 0.18 \times \frac{400^2 - 150^2}{400^2 - 200^2} + 3.17 \times \frac{200^2}{400^2 - 200^2} \\ = 2.396.$$

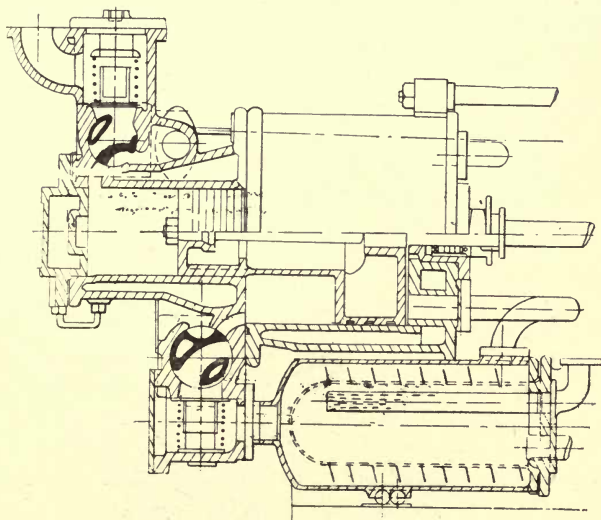

FIG. 251.

The volumetric efficiency on the low-pressure diagram is 0·9821, and the ideal mean effective pressure in atmospheres with isothermal compression

$$p_i = \text{hyp. log. } 6.8 = 1.912,$$

the absolute pressure of compression measured from the end of the high-pressure diagram being 6·8 atmospheres absolute. The efficiency of compression is, therefore,

$$\eta_2 = \frac{1.912 \times 0.9821}{2.396} = 79.4 \text{ per cent.}$$

According to the Breitfeld Danék Engineering Company, the chief advantages of the system are to be found in the fact that—

(1) According to the pressure of compression required, the compressor can be built to work as a two or three stage machine.

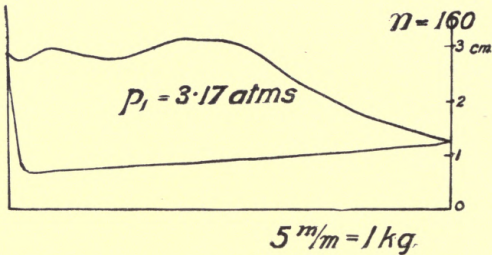

FIG. 252.

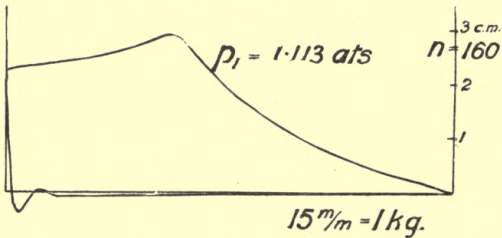

FIG. 253.

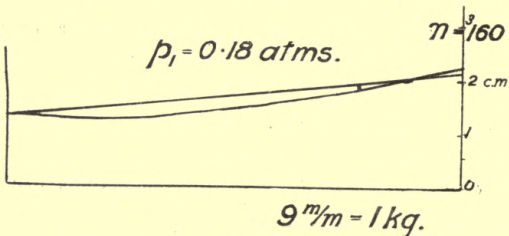

FIG. 254.

(2) Compact arrangement of a two-cylinder machine, saving length as compared to the ordinary tandem engine, or breadth in comparison with a cross-compound arrangement.

(3) Reduction in the number of moving parts, valves, etc.

(4) As twin compressor, each side can be run separately, so that, according to the amount of air required by varying demand, either one or both sides of the machine can be run at will.

(5) Saving in weight and space.

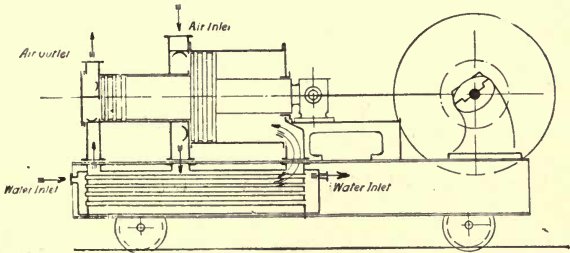

FIG. 255.

Fig. 255 shows in outline a portable Castellain compressor with plate valves for use in coal mines. The smaller the trunk piston rod is made, the greater will be the variation of pressure in the receiver, the less will be the work done as the piston moves to the left, and the more as it moves to the right, so that upon the diameter of trunk depends the variation of pressure on the crankpin.

57. *The "Daw" Compressor.*—We are indebted to Messrs. A. and Z. Daw, of 11, Queen Victoria Street, London, E.C., for the following description of their compressors:—

The distinctive features of the air compressors designed by Messrs. A. and Z. Daw, of London, is the "Daw" method of directly controlling and balancing the inlet and discharge valves by the air pressure, by which means the air is compressed with greater economy, and at speeds of compression hitherto thought unobtainable, with attendant

greater output from the compressor and reduction in first outlay for plant.

The salient features of the Daw valve gear are its automatic controlling, adjusting, and balancing action. The valves are directly controlled and balanced by the air pressure; have a rapid movement, with quick opening and closing; and, when once set, the valve gear is self-adjusting for all speeds and pressures. The valves are practically noiseless in operation, and the wear and tear is scarcely appreciable.

*“Daw” Inlet Valve.*—One large inlet valve (fig. 256) only is used in each head of the compressing cylinder, giving a wide opening and free passage. There is no delayed valve action. During admission each valve is kept wide open, so that the compressing cylinder is completely filled with air at the atmospheric pressure throughout the whole stroke, and during compression there is no loss of any part of the contained air by reflux to the atmosphere. Like results are obtained with gas as with air. From this action of the “Daw” inlet valve full-volume efficiency is obtained, with corresponding greater economy of power in compression than is possible with inlet valves which are operated wholly or partly by “suction pressure,” as, owing to the suction work required to be done to overcome inertia and spring load, they cannot open, or remain open, unless the pressure in the compressing cylinder is less than the exterior pressure. The “Daw” inlet valve system eliminates the great loss of efficiency due to the throttling of the air in its admission to the compressing cylinder, caused by mechanically-operated valves which are closed gradually, and also by automatic or self-acting valves which require a small lift, making large numbers of small valves necessary. The various losses caused by defective inlet valves are saved by the “Daw” inlet valve system; and, although not easily determined, the saving effected thereby is very appreciable.

*“Daw” Discharge Valve.*—One large discharge valve only is used in each head of the compressing cylinder, and to ensure free delivery it is made the same size as the inlet valve. As the “Daw” delivery valve is perfectly

balanced and controlled, it offers the great advantage over all other valve systems that it enables air or other gases to be compressed without "excess pressure," thus saving the serious loss of efficiency which this entails. In all other valve systems the seating always causes "excess pressure," owing to the valve presenting a greater surface to the pressure in the receiver than to the pressure in the compressing cylinder. Further, other valve systems necessitate the reduction of the seating to the lowest possible margin, as will be seen from the following calculations, showing the great loss of efficiency which otherwise would result. There is some risk also that undue reduction of the seating may cause the valve to be leaky in actual work.

A 3 in. circular valve with  $\frac{1}{4}$  in. seating exposes a surface of 7.07 square inches to the pressure in the receiver and 4.91 square inches to the pressure in the compressing cylinder. If, then, air was being compressed to 80 lb. gauge, the pressure on the valve on the receiver side would be  $7.07 \times 80 = 565.5$  lb., which would have to be balanced by an equal total pressure—*i.e.*, 565.5 lb.—on the cylinder side of the valve before it could open and the compressed air be delivered into the receiver. The unbalanced valve, therefore, necessitates a pressure per square inch of

$$\frac{565.5}{4.91} = 115.2 \text{ lb.}$$

in the compressing cylinder, or 35.2 lb. above the required pressure.

On the other hand, a 6 in. circular valve with  $\frac{5}{16}$  in. seating exposes a surface of 28.27 square inches to the pressure in the receiver, and 22.69 square inches to the pressure in the cylinder. The total pressure on the receiver side of the valve before it could open and the compressed and would have to be balanced by a pressure per square inch of

$$\frac{2261.6}{22.69} = 99.7 \text{ lb.}$$

which is an excess pressure of 19.9 lb.\*

\* This reasoning neglects the pressure between the valve and its seat, and therefore over-estimates the lifting pressure.

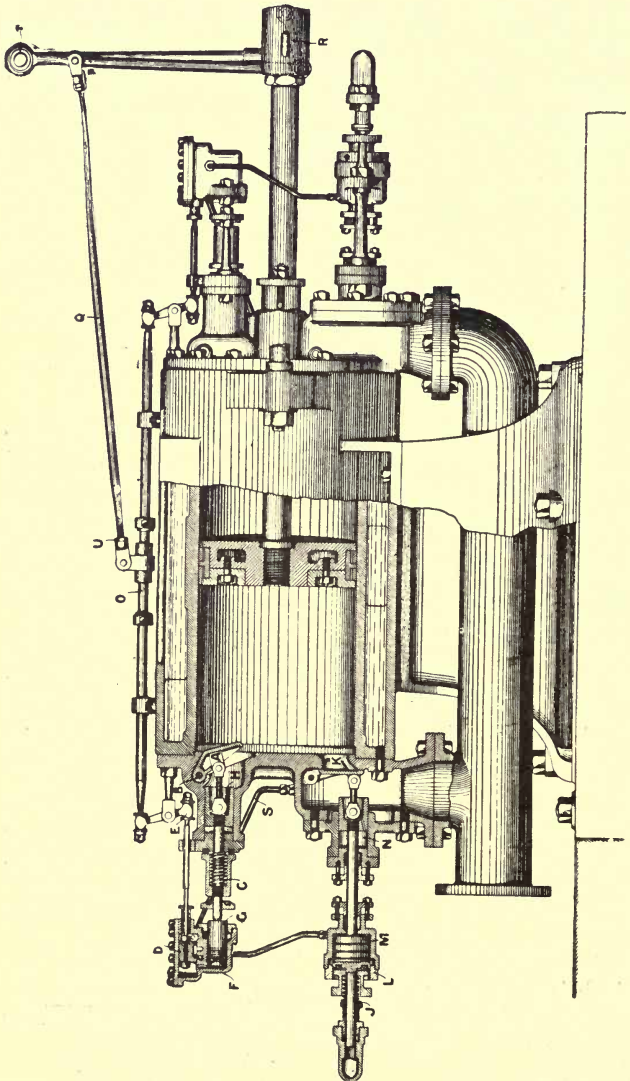

FIG. 256.

In the latter and most favourable case, owing to the excess pressure, the whole volume of air in the cylinder is heated 50 deg. higher than with balanced valves. The increased work during compression only, which this causes, according to the law of the equivalence of heat and work, is 13·4 per cent, and it is much greater for the smaller valve. Owing to some of the "excess pressure" being lost during expulsion of the air under the receiver pressure, the actual loss of efficiency is perhaps not so high as the 13·4 per cent; but, nevertheless, the loss is serious, and is saved by the balanced-valve system. The "Daw" compressors have a water jacket for cooling the air as completely as possible during compression.

#### DESCRIPTION OF ACTION OF "DAW" INLET AND DISCHARGE VALVES.

Taking first the inlet valve gear, fig. 256 shows the inlet valve A in an open position. It is pivoted at B, and opens inwards, its weight and the pressure within the compressing cylinder, and also the strong spring C, tending to keep it closed.

The valve is opened at the commencement of the suction stroke through the small slide valve D, which is actuated by the valve gear E, placing the rear end of small cylinder F in communication with the receiver through pipe S, so that the pressure in the latter acts upon the piston G, to overcome the action of the spring C, and the weight of valve A, such pressure being maintained and the inlet valve thereby kept in its open position, after it has been opened, during the full length of the suction stroke. On the completion of the suction stroke the small slide valve D is reversed to exhaust, and the spring C, being thus relieved from the pressure acting against it, closes the valve. The small cylinders F and H act as dashpots or buffers, and ensure the valve opening and closing quietly without shock. The pressure set up on the inlet valve piston G at the commencement of the suction stroke is sufficient to ensure the inlet valve A opening instantly, and the removal of the pressure causes the equally ready closing of the valve by the spring C.

The discharge valve is shown in its closed position, the spring J, pressure in receiver, and weight of valve K tending to close it. It is pivoted similar to the inlet valve, and is arranged to open outwards in its relation to the compressing cylinder, and is enclosed in a casing in open communication with the receiver, the pressure in which consequently is always exerted on the back of such valve.

The discharge valve K is also balanced through the small slide valve D, which is actuated by the valve gear, placing the front end of balancing cylinder L in communication with the receiver, so that on the pressure in the compressing cylinder becoming equal to the pressure in the receiver, the latter pressure, acting upon the piston M, balances the difference in pressures on the discharge valve K, due to the valve seating, also the spring J, and the weight of valve, causing the discharge valve to open without any excess pressure being set up in the compressing cylinder. As the discharge valve lifts off its seat a portion of the balancing pressure in cylinder L becomes an active force, opening the valve rapidly, and maintaining it full open until the compression stroke is completed. The slide valve D is then reversed by the valve gear, so that the pressure in cylinder L is exhausted, and the strong spring J, being thus relieved from the pressure acting against it, instantly closes the valve. The cylinders L and N act as dashpots or buffers, and ensure the valve opening and closing quietly without shock.

The small slide valve D controlling the small pistons, governing the opening and closing of the inlet and discharge valves, are mechanically actuated as follows:—

To the piston rod is connected a short rod R which actuates the long arm of a lever, the fulcrum T of which is placed a distance above it approximately equal to the travel of the piston. Forming part, or connected with this lever, is a connection nearer to the fulcrum to give a short travel to the rod Q. This has a sliding connection U upon the horizontal rod O, upon which are adjustable stops which actuate the small slide valves D exactly at the end of each stroke of the air compressor, the valves



remaining stationary at all other times. By this positive motion it is ensured with absolute certainty that the valves D will move exactly at the time required, thus causing the admission valves to open and the discharge valves to close in the manner required to give the best results.

The use of a special gear for operating the valves greatly simplifies the compressor, as instead of a large number of small valves only one inlet and one discharge valve are required. All the valve gear is upon the outside, where it is easily accessible for adjustment and attention.

*Automatic Governor.*—Frequently the demand for air is of such an intermittent character that it is of great importance to automatically govern the speed of the compressor according to the quality of air required. This regulation is an important feature of the "Daw" compressor, and is automatically effected by a specially-devised air pressure regulator acting in conjunction with the usual speed governor on the steam valve gear, controlling the cut-off mechanism and regulating the speed of the compressor from maximum to minimum, according to the quantity of compressed air required, so that the consumption of steam is proportioned to that of the compressed air used.

SHOP TEST OF A "DAW" PATENT CLASS E CROSS COMPOUND STEAM AND TWO-STAGE AIR COMPRESSOR.

Registered No. 112.

Date: 25th November, 1903.

*Dimensions of Compressor.*

Low-pressure air cylinder, diameter.....	20½ inches.
High-pressure air cylinder, diameter.....	13 inches.
Low-pressure steam cylinder, diameter .....	24 inches.
High-pressure steam cylinder, diameter .....	12 inches.
Common stroke of all cylinders .....	30 inches.
Clearance of low-pressure air cylinder .....	1.12 %
Clearance of high-pressure air cylinder .....	.90 %
Revolutions per minute during test .....	94
Piston speed.....	470 feet.
Capacity cubic feet of free air at 94 revolutions per minute .....	1077
Reduction in capacity due to clearance in low-pressure cylinder.....	29 c. ft.
Net capacity in free air per minute .....	1048 c. ft.

*Temperatures.*

Shop temperature, Fah. ....	65 deg.
Temperature of cooling water, Fah... ..	80 deg.
Temperature of water jacket, low-pressure air cylinder	88 deg.
Temperature of water jacket, high-pressure air cylinder .....	86 deg.
Temperature of air at exit from low-pressure cylinder...	215 deg.
Temperature of air at exit from intercooler .....	88 deg.
Temperature of air at exit from high-pressure cylinder	214 deg.
Temperature of water passing intercooler .....	90 deg.

*Cooling Water used.*

Quantity of water passing intercooler, gallons per hour .....	1490
Quantity of water passing water jacket, low-pressure cylinder, gallons per hour ... ..	45
Quantity of water passing water jacket, high-pressure cylinder, gallons per hour .....	40

*Pressures.*

Barometer .....	29.9
Initial steam pressure, pounds per square inch .....	140
Intercooler gauge pressure, pounds per square inch ...	21
Receiver gauge pressure, pounds per square inch .....	72
Steam Cylinders—	
Mean pressure: High-pressure cylinder .....	62.3
Mean pressure: Low-pressure cylinder .....	11.25
Air Cylinders—	
Mean pressure: High-pressure cylinder .....	34.85
Mean pressure: Low-pressure cylinder .....	15.67

*Indicated Horse Powers.*

Air Cylinders.		Steam Cylinders.	
Low pressure.....	73.66	Low pressure ...	72.48
High pressure ...	65.89	High pressure ...	100.35
	Total ... 139.55		Total ... 172.83

*Isothermal* power required to compress net capacity of free pressure, viz.: 1,048 cubic feet to 72 lb. gauge ..... 119.47

*Efficiency ratio of compression.*

$$\frac{\text{Total isothermal power}}{\text{Total I.H.P. air cylinder}} \times 100\% = \frac{119.47}{139.55} \times 100\% = 85.61\%$$

*Efficiency ratio between steam and air cylinders.*

$$\frac{\text{Total I.H.P. air cylinder}}{\text{Total I.H.P. steam cylinder}} \times 100\% = \frac{139.55}{172.83} \times 100\% = 80.75\%$$

*Efficiency of compression from atmosphere to receiver.*

$$\frac{\text{Isothermal air}}{\text{I.H.P. steam}} \times 100 \% = \frac{119.47}{172.83} \times 100 \% = 69.13 \%$$

*Remarks.*—During the shop test the compressor was supported on loose foundations only, and when erected in position, on solid foundations, the efficiency between steam and air cylinders, on the known efficiency of similar “Daw” compressors, will exceed 90 per cent, and the efficiency of compression from atmosphere to receiver will in actual work exceed 90 per cent of 85.61 per cent, or 77.05 per cent.

The compressor ran smoothly, and both the mechanical and air governors acted promptly.

*Types of Daw Compressors.*—The Daw compressors are made for either single or multi-stage compression, the compressing cylinders being disposed in such manner that the work of the motor will be a minimum, and according to requirements are built in the following types:—

Direct steam driven.

Driven by oil or gas engines.

Driven by belt or rope.

Driven by water power.

Driven by electric motors.

Sectionalised for mule or manual transport.

*Single Straight-line Class “E” Daw Compressor.*—A view of one of these is shown in fig. 257. The inlet and discharge valves of the compressing cylinders are as described; the air cylinder is placed tandem with the steam cylinder. The steam cylinder has Richardson’s trip gear, which obviates the friction due to slide valves, and maintains the speed of the engine practically constant, whilst giving a perfect distribution of steam under all loads. The governing, as will be seen from the illustration, is controlled by the automatic air-pressure regulator, in addition to the usual speed governor.

This compressor has a free air capacity of 790 cubic feet per minute compressed to a pressure of 80 lb. per square inch. The number of revolutions is 100 ft. or 550 ft. piston speed per minute.

*Cross Compound Two-stage Air Compressor with Air Washer.*—This compressor was built by Messrs. A. and Z. Daw for a colliery in Natal, an express condition being that

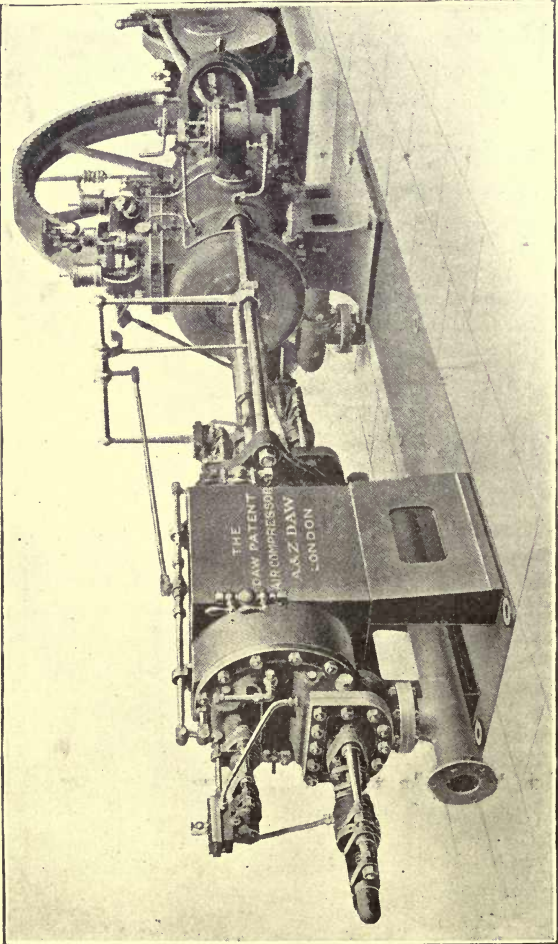

FIG. 257.

they were to provide an air washer, through which all the air was to be drawn and thoroughly washed before entering the low-pressure air cylinder. The capacity of the compressor is 2,500 cubic feet of free air per minute at sea level, compressed to 90 lb. per square inch, running at 90 revolutions or 600 ft. piston speed per minute. The

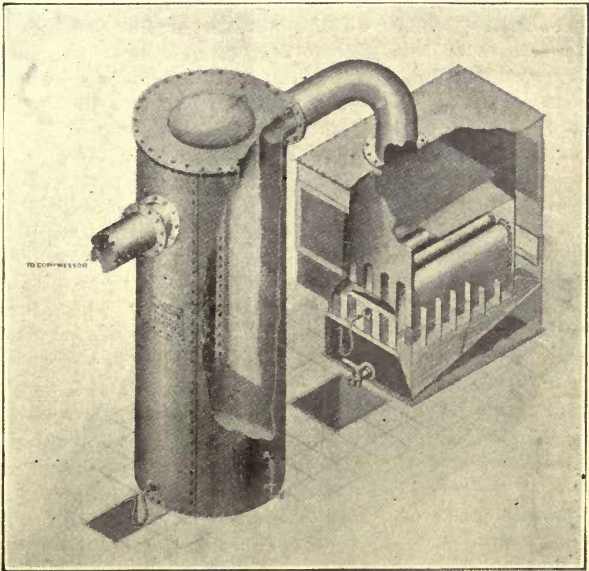

FIG. 258.

cylinders, as in all Daw compressors, are water-jacketed, and the air cooled between the stages, and in this way the isothermal condition of compression is approached. The intercooler consists essentially of a large number of tubes, through which there is a constant flow of water, the air being compelled to traverse across the tubes by a series of baffle plates, by which means the air is split up and every particle brought into intimate contact with the

cooling surface of the tubes. The water for cooling and the air which is being cooled are arranged to flow so that the air just before it leaves the intercooler meets with the coldest water.

The air washer designed by Messrs. A. and Z. Daw is shown in fig. 258. It is extremely simple and remarkably efficient. The inlet openings are protected by wire gauze, and arranged on opposite ends of the washer to balance any suction pressure on the surface of the water. The air passes down through the end vertical channels, and is distributed through five horizontal troughs over the surface of the water in the washer. Slots are cut in the side plates of each of the troughs, and the air, in passing through these slots, is split up into thin streams and thoroughly washed by the water, which normally covers the slots to a depth of 3 in. The vertical baffle plates arranged along the troughs are to prevent swishing of the water, and the horizontally-inclined baffle plates are to arrest any particles of water carried up by the air, and as a further precaution a vertical water separator is introduced between the washer and compressor. A sludge cock is fitted for periodically washing out the sludge that may accumulate.

The action of the air washer was exhaustively tested by Geo. A. Goodwin, Esq., M.I.C.E., Wh.Sc. Hoppers were fixed in front of the wire-gauze protected openings, and fine coal dust fed into them, the compressor being run at its full speed of 90 revolutions per minute for about twenty minutes. The pipe leading the air from low-pressure cylinder to intercooler was disconnected, and a large clean duck bag secured thereto, through which all the air from the low-pressure cylinder during the trial had to pass. About  $1\frac{1}{2}$  cwt. of dust was fed into the washer, and, so far as observation was possible, every particle was separated in the washer, the bag being quite clean at the end of the run. The piping was then coupled up, and a full run of 55 minutes' duration made, during which 150,000 cubic feet of free air were drawn through the washer, the loss of water during the run being 2 gallons, or 1 gallon for 75,000 cubic feet of free air. A vacuum

gauge attached to the washer was not sensitive enough to record any reduction in pressure below the atmospheric pressure.

Altogether the run was highly successful, and most gratifying to the designers.

*Belt-driven Daw Compressor.*—On fig. 259 is shown a reproduction of a photograph of a two-stage belt-driven compressor, the test of which is given on page 259.

*Sectionalised Daw Air Compressor.*—The compressor shown on fig. 260 represents probably the most remarkable example of sectionalised air compressor ever built, and was built by Messrs. A. and Z. Daw for a gold mine in Ashanti before the advent of the railway to Kumasi.

The compressor is of the direct-acting duplex type, with a capacity of 624 cubic feet of free air per minute, compressed to 70 lb. per square inch, running at 133 revolutions, or 400 ft. piston speed, per minute. Its destination was 110 miles up country, the pathway to the mine being for the greater part through a primeval forest, and the difficulties of transport were so great that the limits of weight of each section was fixed at 80 lb. to 90 lb., except for the cylinders, crankshaft, and rims of flywheels, which parts were limited in number, and not to exceed 250 lb. each in weight packed. The gross weight of the compressor was 15½ tons, and was carried the 110 miles inland by 600 carriers, over rivers and through swamps, many of which were dangerous to human life. About two months were occupied in the transit through the bush, and the whole was safely delivered without loss or damage to any part. This compressor has now been at work for several years, and, although built up in the remarkably small sections above described, has worked with the greatest smoothness and steadiness, and with complete immunity from breakdowns and repairs.

58. *Bailey's "Köster" Air Compressors.*—These are constructed by Messrs. W. H. Bailey and Company, Albion Works, Salford, Manchester. They belong to that type in which there is a reciprocating part or parts forming the suction valve, and also closing the discharge passage at the end of the stroke, but which also have self-acting

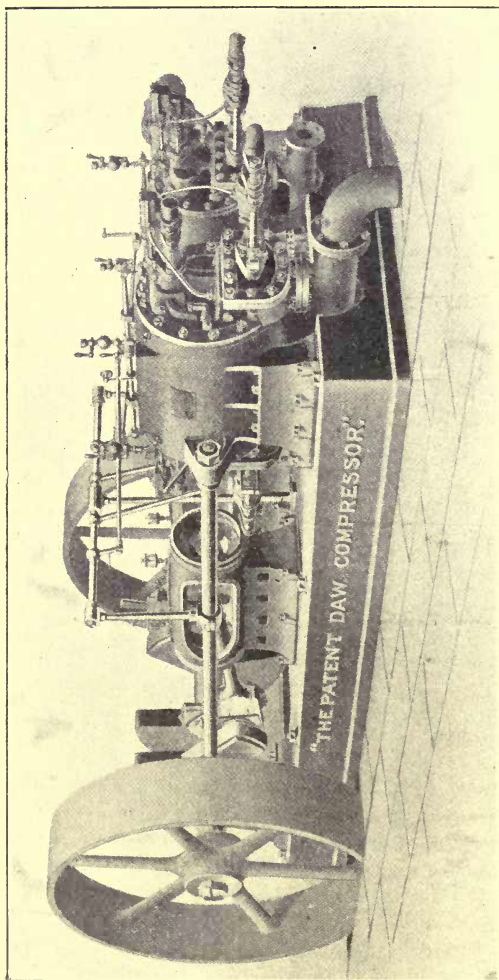

FIG. 259.



TEST OF A TWO-STAGE BELT-DRIVEN AIR COMPRESSOR FOR  
 TERMINAL AIR PRESSURES OF 70 LB. AND 80 LB.  
 GAUGE PER SQUARE INCH.

Class K. Size 17 in. and 11 in. × 24 in.

Date, 5th December, 1902.

Shop temperature 65 deg. Fah.

Barometer 30·2 in.

	Receiver gauge pressure.			
	70		80	
Revolutions per minute .....	70	104	116	88
Piston speed, feet per minute .....	280	416	464	352
Capacity, cubic feet free air per minute .....	441	656	732	555
Temperature of cooling water, Fah. ....	56°	56°	56°	56°
Temperature of water jacket, L.P. cylinder....	86°	86°	86°	87°
Temperature of water jacket, H.P. cylinder ..	91°	91°	93	98°
Intercooler gauge pressure.....	21	21	21	22
Temperature of air at exit from L.P. cylinder to intercooler ....	137°	202°	207°	208°
Temperature of air at exit from intercooler....	70°	73°	75°	72°
Temperature of air at exit from H.P. cylinder.	206°	212°	218°	222°
Temperature of water passing intercooler ....	63°	65°	70°	66°
Quantity of water passing intercooler, gallons per hour .....	702	702	730	730
Quantity of water passing waterjacket, L.P. cylinder .....	33	33	33	33
Quantity of water passing water jacket, H.P. cylinder .....	30	30	30	30
I.H.P. of L.P. cylinder .....	28·65	44·30	50·75	38·25
I.H.P. of H.P. cylinder .....	27·00	42·00	47·50	37·00
Total mean I.H.P. of air cylinders .....	55·65	86·30	98·25	75·25
Total isothermal power required to compress air at rated speeds and pressures .....	49·56	73·74	82·27	66·22
Efficiency of the compressing process, viz. :—				
$\frac{\text{Total isothermal power}}{\text{Total mean I.H.P.}} \times 100$ per cent.	89·06%	85·45%	83·74%	88%

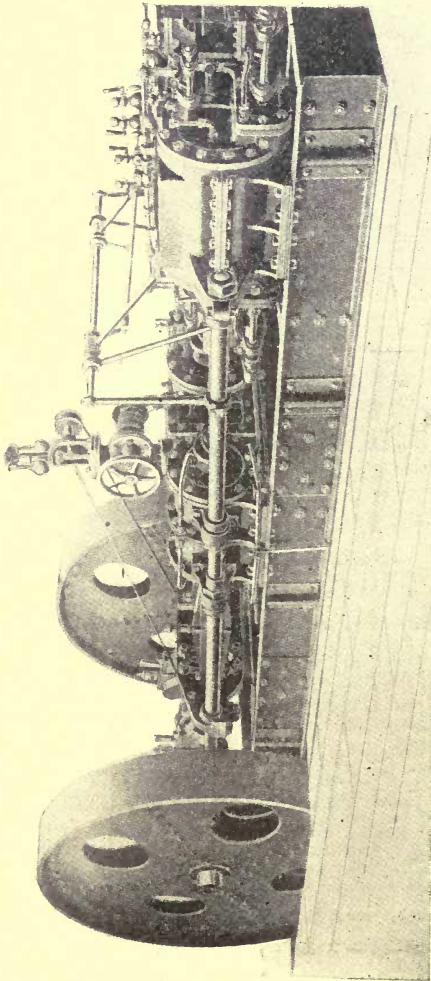

FIG. 260.

discharge valves, which control the movement of discharge. The action of the valves is shown in figs. 261, 262, and

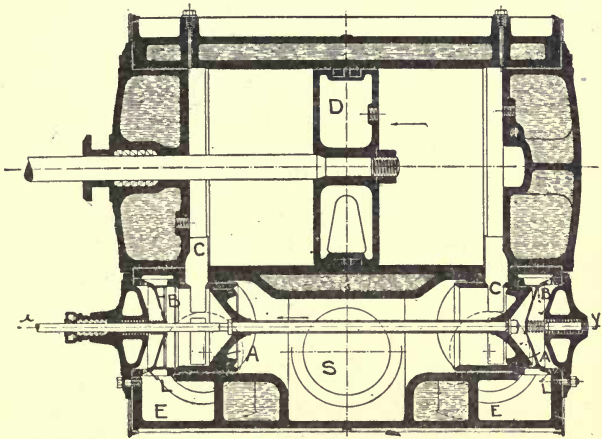

FIG. 261.

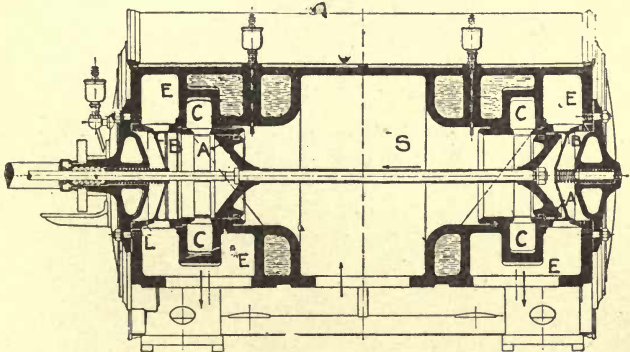

FIG. 262.

263, which represent a double-acting cylinder fitted with Köster's patent piston valve gear. The air enters through a suction pipe at S. In fig. 263 the piston is moving to

the left, so that air enters from S by the port C to the right-hand side of the piston. The piston valve has opened both ports C, C, and the air can pass without throttling. On the left-hand side of the piston the air drawn in previously is being compressed, and when it reaches the final pressure the valve B opens, and the air is discharged to the delivery pipe. The piston valve A is now moving to the left, and closes the port C exactly when the piston arrives at the end of its stroke. As the suction stroke

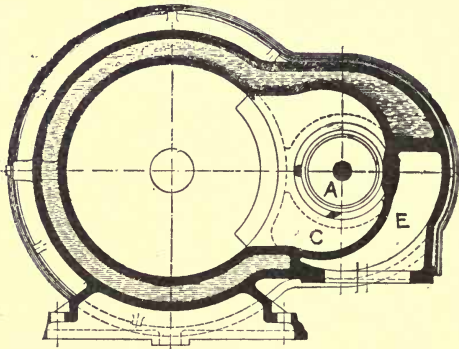

FIG. 263.

on the right-hand side is completed at the same time, the port at this end is closed at this moment, so that the piston valve prevents communication between the left-hand side of the piston and the discharge chamber E, and the right-hand side and the suction space S. The piston D now moves in the opposite direction, and during this time the piston valve passes through its middle position to the left, opening the port C at the left-hand end of the cylinder to S, and the port C at the right-hand end. The space to the right of the piston is not connected with the discharge chamber E until the pressure on the right of the piston is sufficient to open the right-hand self-acting valve B. It is claimed that the Köster valve gear has the following advantages:—

(1) It offers no resistance to the entrance of the air; (2) the entering air is not heated during the suction stroke; (3) it gives the highest volumetric efficiency; (4) it has no defects inherent in the design; (5) there is no resistance to the discharge of air from the cylinder; (6) is suitable for all speeds; (7) noiseless; (8) wear and tear are reduced to a minimum; (9) and is positive, safe, and reliable.

The self-acting valves are seated by a light spring, and *not by a difference of pressure*; in fact, they seat themselves on an air cushion between them and the piston valve ends. Many serious accidents and fires have been caused by the explosion of the oil vapour from the lubricating oil in the receivers and cylinders of air compressors. These explosions are always possible with automatic valve compressors, as their valves are liable to stick, and do not seat themselves properly. The sticking of the valve causes leakage, and some of the compressed air flows back to the cylinder from the discharge pipe, and the consequence is that the hot air raises the temperature in the cylinder so much that at the end of the next compression stroke it is sufficiently high to vaporise the oil, and fire the mixture of the gas and air. With the Köster patent mechanically-operated valve gear the risk of cylinder and receiver explosions is entirely eliminated in both single and two-stage compressors.

Figs. 264, 265, 266, and 267 are sectional views of Bailey's "Köster" two-stage compressor, while fig. 268 shows indicator diagrams. In fig. 264 the differential air piston P is actuated by the connecting rod R; the piston air valve by means of the eccentric O and rod S. Free air is being drawn through the suction opening A, and passes through the port B to the cylinder, the piston valve C being on the right-hand side of the port at the time. When the air piston arrives at the end of its stroke the piston valve C closes the port B, and on the return stroke the air drawn previously into the cylinder is compressed. On the desired pressure being reached, the piston valve C having some time before opened the port B, and passed to the left-hand side of it, the compressed air flows through the spring

valve D to F. The first stage of the compression is now completed, and the air thus compressed passes through an intercooler to H on the high-pressure side of the

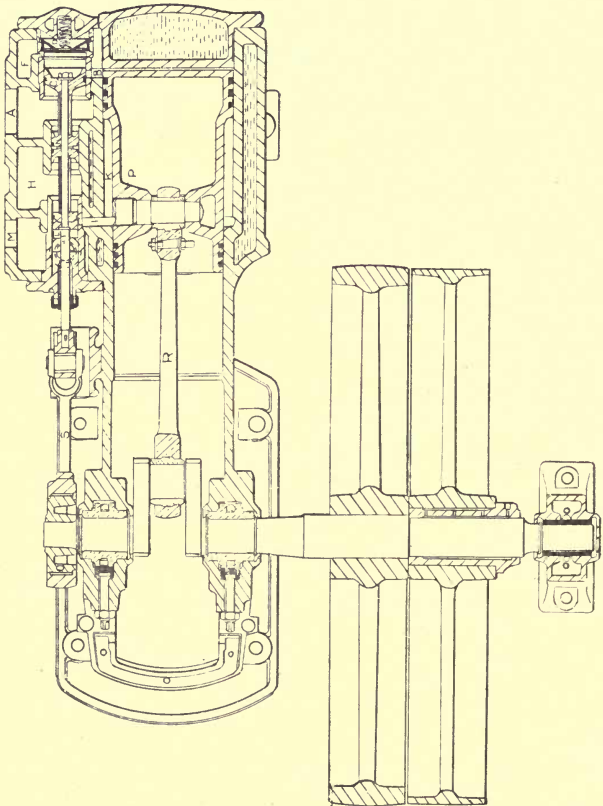

compressor. From H it passes to the annular space K, the air piston moving towards the right-hand side of the cylinder, and the piston valve L being at the left-hand side

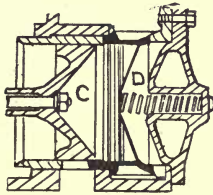

FIG. 265.

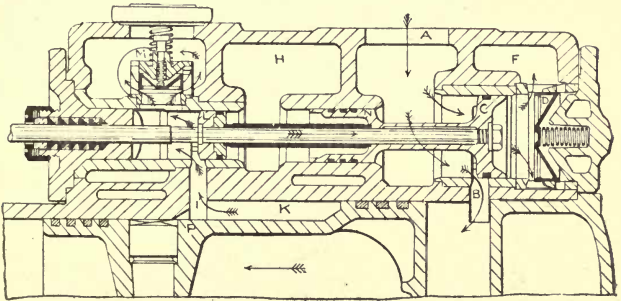

FIG. 266.

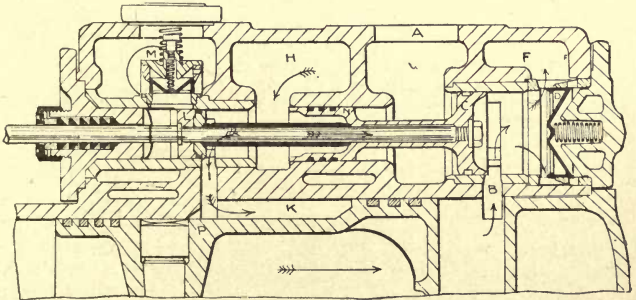

FIG. 267.

of the port I, so that in the same stroke towards the right-hand side the air compressed in the first stage of compression is discharged through port B and drawn in through port I. On the return stroke to the left-hand side free air is again drawn in through the port B, and the air in the space K is compressed to the final pressure, and now passes through I to the spring discharge valve, and into the delivery pipe at M. A special advantage in this valve gear must be noticed. If Corliss valves are used in place of the

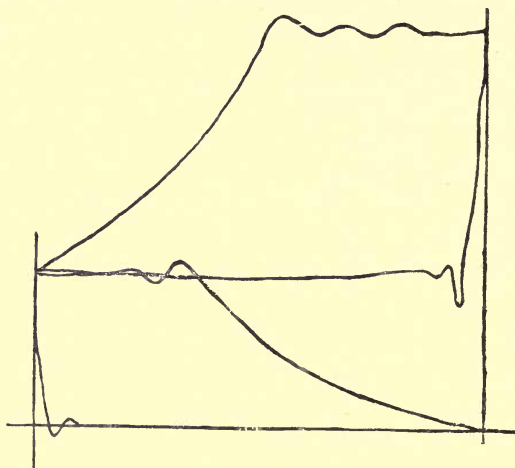

FIG. 268.

piston valve the air between the discharge Corliss valve and the self-acting valve is re-admitted to the cylinder near the beginning of the compression stroke, and this sudden fall in its pressure causes a loss of efficiency; but the piston valve C, after it has closed the port B with its right-hand edge, continues its motion to the right, and forces out the compressed air left between it and D through D into F. Thus in fig. 266 the piston C is moving to the right and discharging the air as explained, although on its left-hand side free air is flowing through B. In fig. 267 discharge is taking place from the low-pressure side of



BAILEY'S "KÖSTER" BELT-DRIVEN SINGLE-CYLINDER TWO-STAGE COMPRESSOR. Fig. 255.

Free air per minute .....	38.5	78.3	116.0	156.4	236	320
Diameter of differential pistons .....	7.87-6.69	10.23-8.66	11.81-10.07	13.38-11.41	15.74-13.38	17.71-15.15
Length of stroke .....	5.9	7.87	9.84	11.81	13.78	15.74
Revolutions per minute .....	250	225	200	175	160	150
B.H.P. required for—						
90 lb. ....	7.1-7.8	13.7-15	19.8-22	26-29	38.5-41.5	49-54
105 lb. ....	7.5-8.3	14.7-16.2	21.5-24	27.8-31	40.5-44.5	53-59
120 lb. ....	8.1-9	15.7-17.3	23.3-26	29.8-33	43-47.5	57-64
Fast and loose pulleys .....	32	40	50	60	69	80
Diameter of—						
Inlet .....	2.5	3.5	4.5	4.5	5.5	6.5
Discharge .....	1.5	2	2.5	3	4	4.5

the piston, and suction on the high-pressure side. The reciprocating valve has a guide N, which is fitted with spring rings. The two piston valves work in fitted liners. The piston and spring valves are very accessible, separate covers being provided for access to each spring valve; no other part need be removed. The water jacket completely surrounds the reciprocating piston, the cylinder head, and

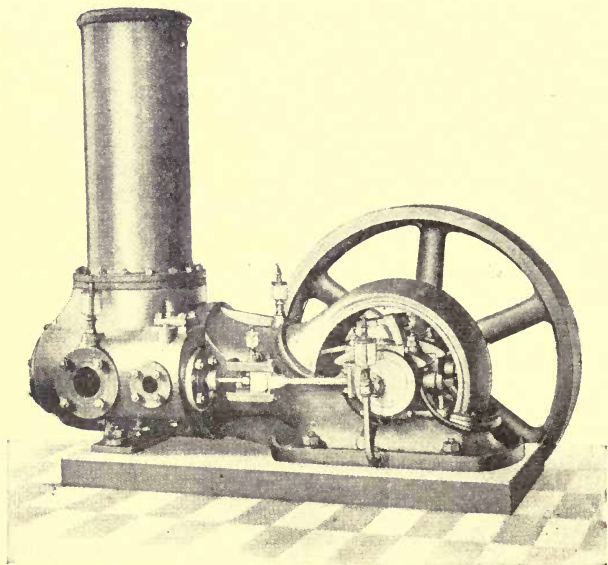

FIG. 269.

the air valve chest. The cooling water in the jacket also circulates through the intercooler. The cooling of the high-pressure side is particularly effective, as the inner or high-pressure side of the piston is always in contact with the external air, and the water-jacketed surface is very large compared with the annular volume. The intercooler is mounted on the top of the machine (fig. 269) in the most accessible position. All sizes are suitable for pressures

from 70 lb. to 150 lb. per square inch, and are proportioned for continuous working at the latter pressure. In the smaller sizes the cylinder and frame are cast in one piece. The whole arrangement, being very rigid and compact, requires very small foundations and very little attention.

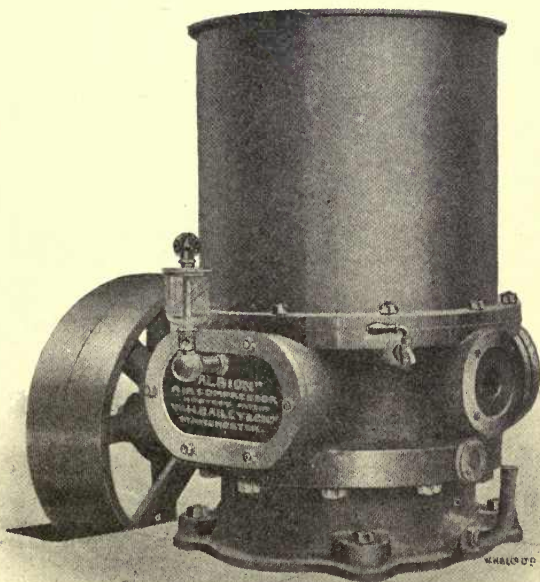

FIG. 270.

The bearings are of the very best metal, and of generous proportions; lubrication is automatic and continuous, the supply to the bearings being on the ring principle, and to the other parts of the machine from adjustable sight-feed lubricators. The leading dimensions of these compressors are given in the table on page 267.

Figs. 270 and 271 show vertical belt and electrically-driven two-stage air compressors. Messrs. Bailey and Company claim that this type is lighter and more compact than

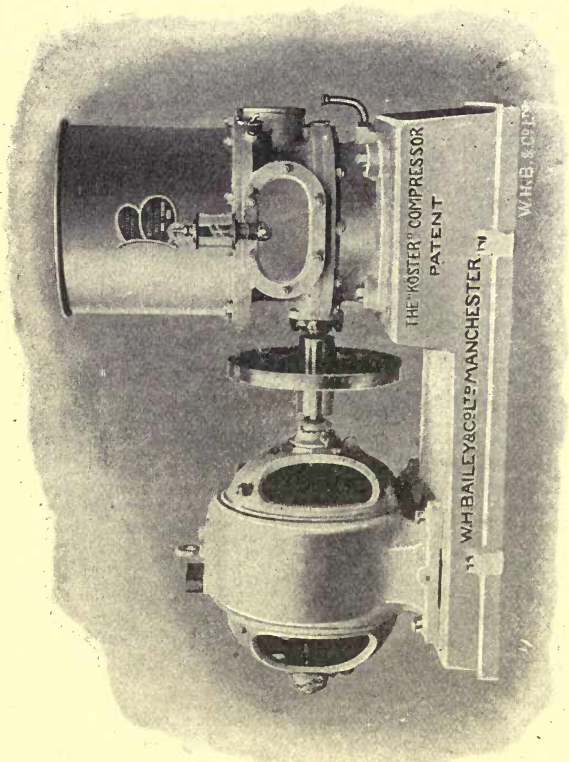

FIG. 271.

any other compressor made. All sizes have water jackets and intercoolers. The working parts are enclosed and dust-proof. It is very suitable for arrangement as a portable plant in combination with a steam, oil, or electro motor.

AIR COMPRESSORS.

Free air delivered per minute...cubic feet	7 55	9 92	18 52	41 26	75 89	109 99
Diameter of differential pistons .....	3 54, 1 65	4 32, 2 16	5 89, 2 95	8 26, 4 12	10 23, 5 11	12 59, 6 68
Length of stroke.....	3 14	3 14	3 14	3 93	4 72	4 72
Revolutions per minute .....	600	550	550	500	500	500
B.H.P. required for—						
90 lb. ....	1 7—2 07	2 3—2 7	4 3—5 0	9 6—11 4	17 7—20 9	25 8—30 5
130 lb. ....	2 0—2 3	2 8—3 3	5 3—6 3	11 5—13 6	21 3—25 2	30 9—36 5
180 lb. ....	2 5—3 03	3 3—4 0	6 3—7 4	14 0—16 5	25 8—30 5	37 3—44 1
Fast and loose pulleys .....	20	20	24	30	36	42
Diameter of pipe—						
Inlet.....	1 5	1 5	2	2 5	3 5	4 5
Discharge .....	$\frac{3}{4}$ gas	$\frac{3}{4}$ gas	1 gas	1 5	2	2 5

It is extensively used for starting large gas engines, raising, stirring, and cooling liquids, working pneumatic tools and machines, blowing dust out of dynamos and motors, inflating and testing rubber goods, etc.

The table on page 271 gives leading dimensions (figs. 270 and 271).

Figs. 272 and 273 show a compound tandem two-stage air compressor by the same firm, and similar engines with only one steam cylinder are also constructed by this firm. Fig. 272 is a general view, and fig. 273 an elevation and sectional plan. The compressing cylinder has been already described; the high-pressure steam cylinder is fitted with equilibrium double-beat lift valves, with coiled spring closure cushioned by oil dashpots. The low-pressure is fitted with similar valves or Corliss gear. The high-pressure valve gear is driven from a cross shaft by eccentrics, is controlled directly by the governor, and is fitted with a disengaging motion. Admission is from 0 to 70 per cent. The governor is designed to control the speed or the capacity. The number of revolutions is adjustable by hand between large limits. If desired, it can be arranged to regulate the speed automatically, and to stop the engine when a certain speed is reached. The following table gives the leading dimensions of two sizes of this type:—

TWO-STAGE COMPOUND AIR COMPRESSOR. FIGS. 272 AND 273.

Free air per minute, in cubic feet.....	808·6	1059·3
Diameters of differential pistons..... large	25·00	28·14
"    "    "    .....small	20·27	22·83
Diameters of steam cylinders....high-pressure	12·8	13·80
"    "    "    ....low-pressure.	20·67	22·44
Length of stroke.....	21·65	23·62
Revolutions .....	145	140
B.H.P. required in steam cylinders for 90lb. air pressure .....	150 to 160	195 to 209

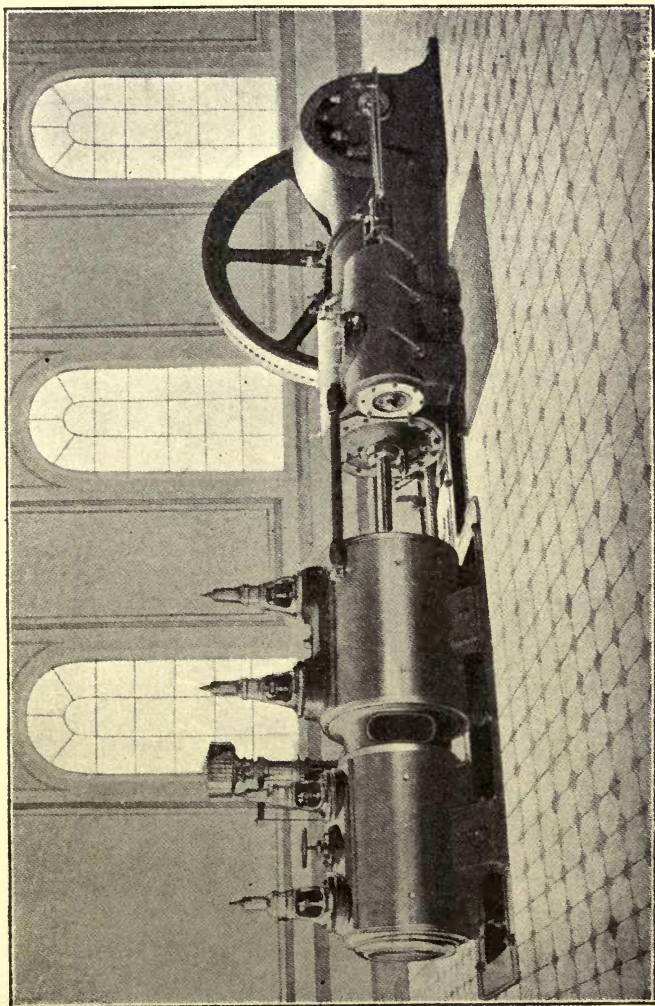

FIG. 272.

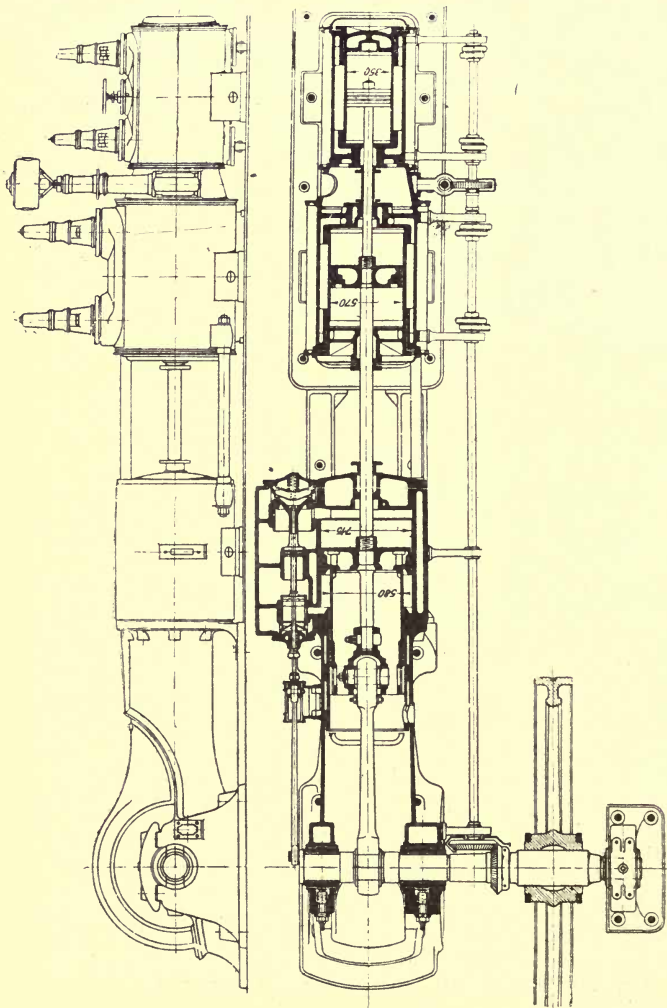

FIG. 273.



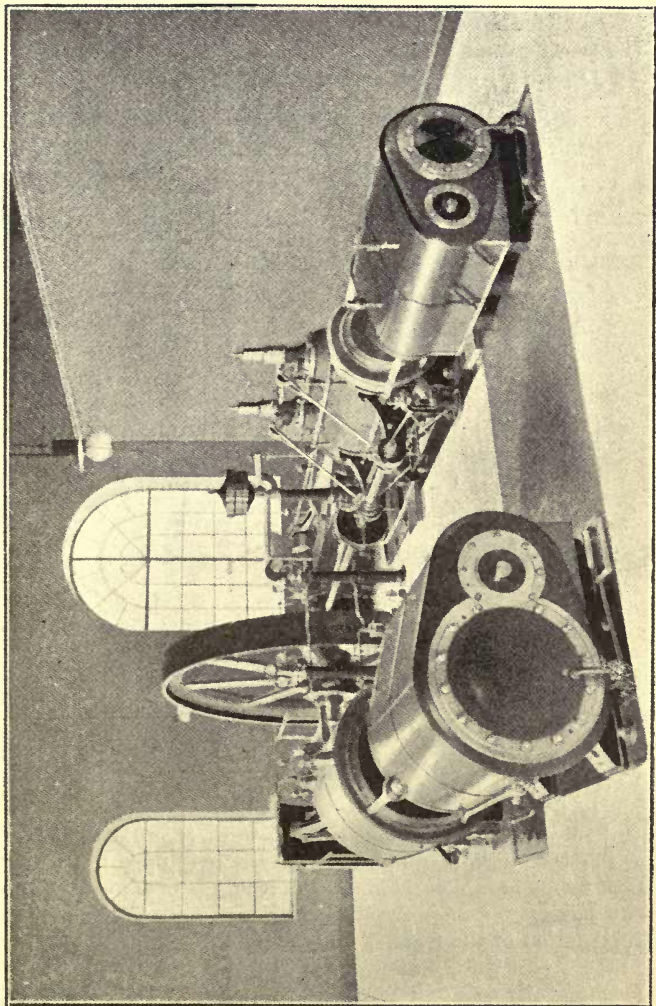

FIG. 274

Fig. 274 shows a cross-compound two-stage compressor. The leading dimensions of this type are given in the following table:—

CROSS-COMPOUND TWO-STAGE AIR COMPRESSORS.

Free air per minute.	Diameters of air cylinders.		Diameters of steam cylinders.		Length of stroke.	Revolutions per minute.	Brake horse power required in steam cylinders for 90 lb. air pressure.
950	19·68	12·40	14·56	22·44	27·56	110	163—173
1180	22·05	13·78	15·75	24·60	29·52	100	216—230
1765	26·57	16·73	18·70	29·13	33·46	90	320—337
2365	29·52	18·70	20·67	32·50	37·40	85	415—445
3000	33·46	21·06	23·62	37·00	41·39	80	530—570
3650	35·8	22·63	25·00	39·37	45·27	76	640—685
4410	38·39	24·21	26·57	42·32	49·23	72	770—825
5420	42·32	26·57	29·13	46·26	53·16	68	950—1010
6700	48·23	30·51	33·46	52·75	53·16	65	1175—1245

59. *Express Compressors*.\*—Probably the greatest improvement in compressor valves has been made by Professor Stumpf, because with these a very high speed is obtainable, and consequently the size of compressor for a given power is much reduced. These valves open inwards in the opposite direction to the flow of air, and are closed by the piston in the same direction as that in which the air is flowing. These are undoubtedly mechanically-controlled valves, but special gear to work them is dispensed with; the valve piston, whose duty it is to open the valve, also forms an air cushion, and during the opening supplies the necessary pressure, and controls the acceleration and retardation of the mass of the valve, and acts as a vacuum brake at the commencement of closing. Other mechanically-controlled valves are too complicated for

\* "Kompressoren," by A. Riedler.

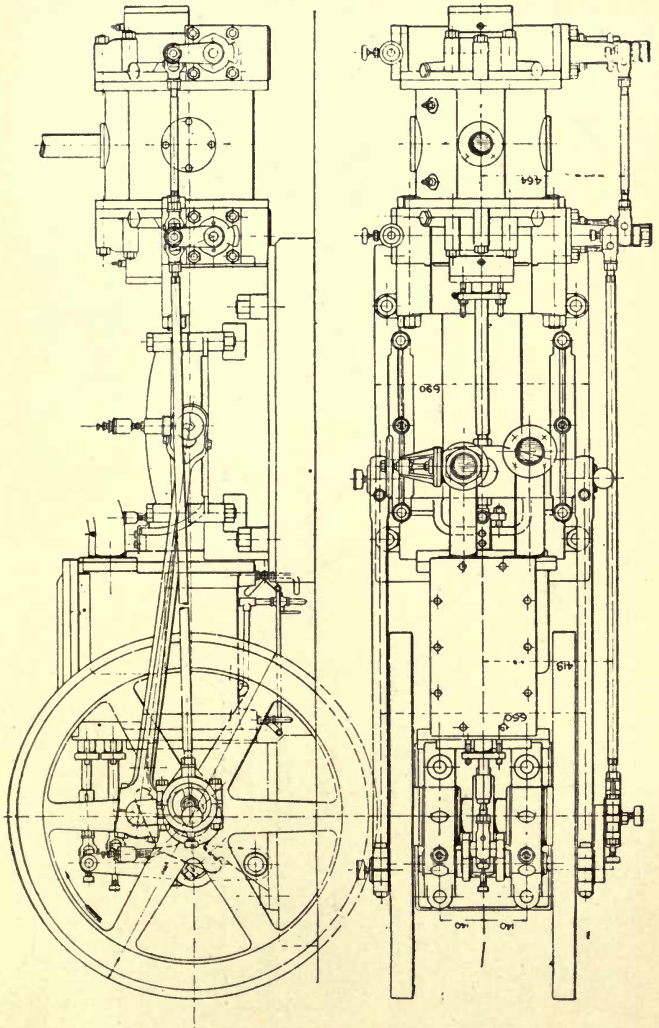

FIG. 275

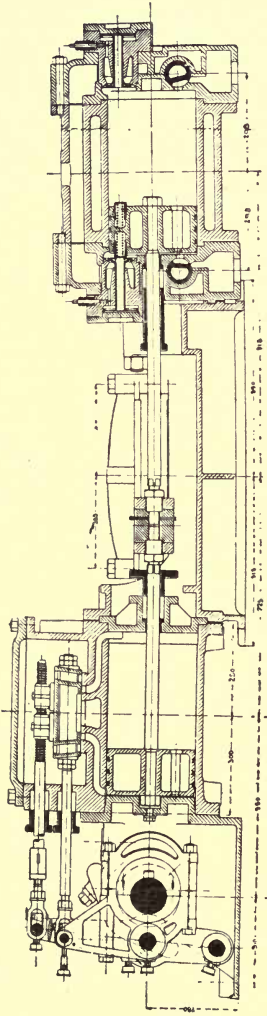

FIG. 276.

small compressors, for which there is increasing demand. Figs. 275 and 276 show a small compressor of 270 mm. diameter (10.63 in.) and 350 mm. stroke (13.8 in.) constructed for experimental purposes by A. Borsig, in Berlin-Tegel, and tested in the engine laboratory of the Berlin Technical High School. The compressing cylinder is bolted to the guide casting at one end, and the steam cylinder at the other. Behind the steam cylinder are the crank-shaft bearings, cast in one piece with the

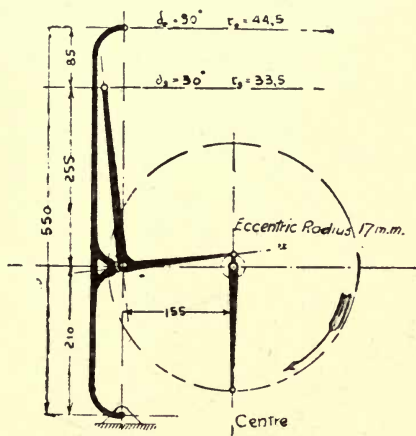

FIG. 277

cylinder cover. The crank is driven from the piston rod by a crosshead and two connecting rods. The steam valves are driven by a gear whose centre lines are shown in fig. 277, from which its action will be readily understood. Its action is the same as that of two eccentrics, one having a small angle of advance driving the distribution valve, and the other having an angle of advance of 90 deg. driving the expansion valve.

The suction valves are Corliss, and are driven by a return crank, connecting rod, and crank arms (fig. 275). The opening of the discharge valves, which are "express

valves," is effected by the pistons at their outer ends, and their closing by the compressing piston, in which there are springs to lessen the shock of contact. The air from the compressing cylinder passes through the centre of the valve to the back of the piston, and when it has risen slightly above the discharge pressure, it opens the valve; the escape of the air at the back is controlled by a screw

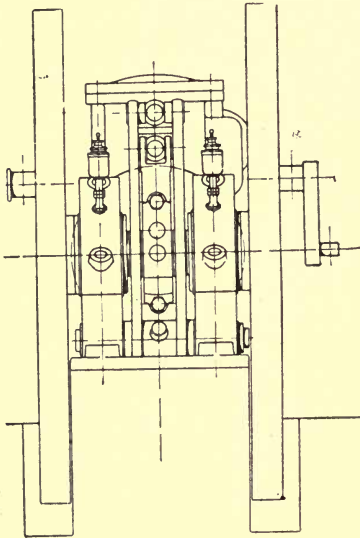

FIG. 278.

(fig. 279), so that an air cushion is formed. When the piston closes the valve, the other side now forms the air cushion, the air escaping through the small holes at the right-hand end of the valve (fig. 279). The springs in the piston were compressed  $1\frac{1}{2}$  mm. when the piston was at the end of the stroke. Satisfactory diagrams were obtained up to 200 revolutions per minute; they had all, however, a sudden rise of pressure at the commencement of discharge, after which the pressure fell to that

at the end of discharge, which was also the same as that in the receiver. Fig. 281 shows two diagrams at 50 and 160 revolutions, and 4 atmospheres pressure by gauge.

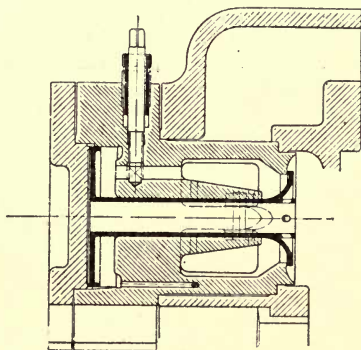

FIG. 279.

The size of the valves was fixed for 120 revolutions, and it was not surprising to find that at speeds above

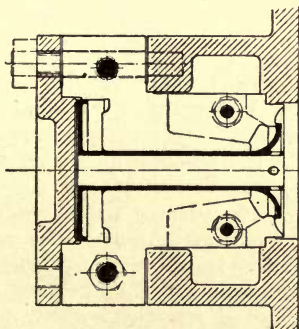

FIG. 280.

150 revolutions suction was noisy, and the diagrams showed a considerable fall of pressure below that of the atmosphere.

In order to study the motion of the discharge valves during these experiments, diagrams of valve motion were taken by connecting the valves directly with the pencil of an indicator, as the valve stroke was less than that of the indicator piston. The valve motion is shown by the ordinates (fig. 282), and the abscissæ are proportional to the stroke of the piston. A series of diagrams were taken in which the resistance of the air cushion was varied to suit the revolutions. These are shown in fig. 283 the figures annexed to the curves denoting the revolutions. It will be seen that up to 60 revolutions the velocity with

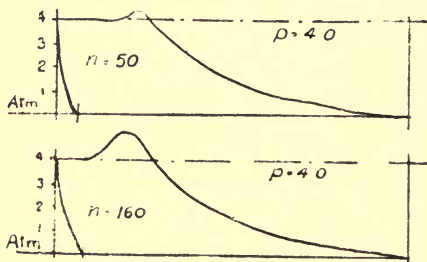

FIG. 281.

which the valve opens is uniform. Above this speed, however, the line of opening is curved, showing that the air cushion acts more effectively towards the end of the valve stroke, and the opening increases with the speed. At a constant speed, by increasing air cushioning, the opening of the valve is reduced. In none of these experiments could any irregular motion of the valve be noticed.

Diagrams were also taken at 50 to 200 revolutions with very little air cushioning. All of these showed at first a uniform velocity of opening, which fell off towards the end, and a quick closing with uniform velocity shortly before the end of the stroke. Fig. 284 shows similar diagrams in which the drum of the indicator was not connected to the piston rod, but was driven by an eccentric in such a manner that when the valve closed



the indicator drum was moving at a high speed. The opening curve is now on the right and the closing on the left, and the valve was not acted on by the piston during the last 3 mm. of its motion when closing. The closing curve shows the rapidity with which the valve

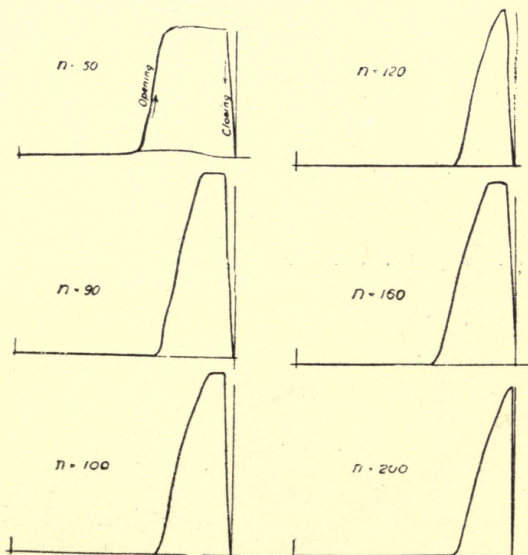

FIG. 282.

is partially closed by the piston, and the slowness with which the closing is completed automatically after the dead centre has been passed.

These diagrams were taken at various revolutions, and showed that the higher the speed the sooner after the dead centre was the valve closed. Diagrams were also taken in this way when the valve was mechanically controlled during its whole closing stroke. The closing takes place shortly before the dead centre, and at high speeds the valve re-opens again slightly and closes again

before the dead centre is reached. This, however, is not noticeable in the compressor diagram. This is an illustration of the experimental work done in German technical schools, which differs somewhat from the testing of toy

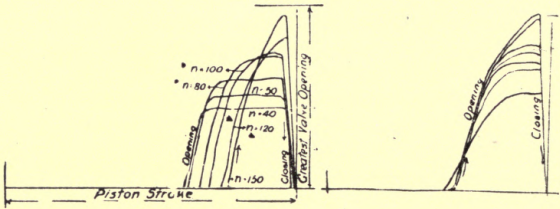

FIG. 283.

cranes and jacks, and the measurement of the kinetic energy of toy flywheels and the like, which is now recommended for English colleges.

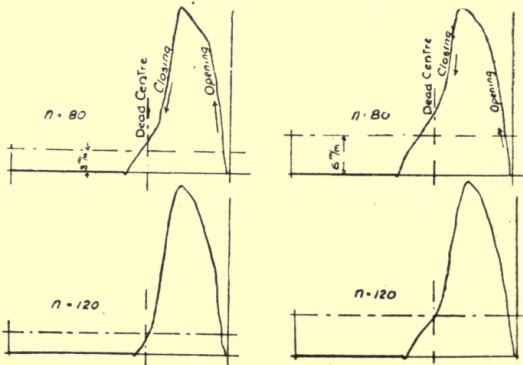

FIG. 284.

As a comparison between equivalent sizes of compressors, the three crank engines at the Quai de la Gare, Paris, are 12.2 metres high, and take up a floor space of 11.5 by 6.15 metres. An equivalent express compressor would be 5.7

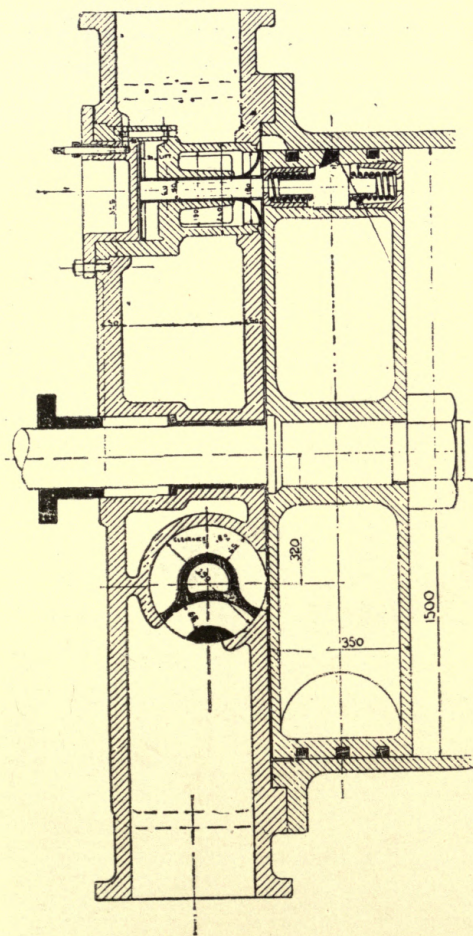

FIG. 285.

metres high, and take up a floor space of 7·1 by 5·3. Fig. 285 shows the cylinder and cover of a large blowing engine fitted with express delivery and Corliss suction valves. Gas power for blowing engines is coming into fashion, and high speeds are necessary if the power of the gas is to be used efficiently, and for this reason express valves have been much used.



# INDEX.

## A

Air Compressor:—  
Allis-Chalmers Co.'s, 196.  
Bailey's "Koster," 257.  
Boreas, The, 176.  
Brotherhood, 178.  
Castellian, by the Breitfeld Danek Co., 240.  
Daw, 245-257.  
Daw, Belt-driven, 257.  
Daw, Sectionalised, 257.  
Delivery Valves, by the Gutehoffnungshütte, 167.  
Duncan, Stewart, and Co.'s, 132.  
Elwell and Son's High-pressure, 191.  
Express, 276.  
Francois, 214.  
Humbolt, 172.  
Ingersoll-Sergeant, 143.  
King Riedler, Double, 197.  
Koster, Bailey's, 257.  
Kryszat, 134.  
Reavell, The, 150, 159.  
Reuniaux, Test of, 31.  
Richardson, Westgarth, and Co.'s, 222.  
Riedler, Test of, 33.  
Schaffer and Budenberg's Kryszat, 134.  
Sentinel, Alley and MacLellan's, 182.  
Suction and Delivery Valves, by the Friedrich Wilhelm Hütte, 124.  
Tilghman's Patent Sand Blast Co.'s, 128.  
Worthington Pump Co.'s, 228.

Air Compressor Valves:—  
Davey, Paxman, and Co.'s, 146.  
Guttermuth's, 170.  
Hughes and Lancaster's, 224.

Air Compressors, Compound, 18.  
Air Compressors, Compound, Bailey's Köster, 272, 276.  
Air Compressors, Compound, Breitfeld, Danek Engineering Co.'s., 232.  
Air Compressors, Compound, Daw, 251.  
Air Compressors, Compound, Duncan, Stewart, and Co.'s., 132.  
Air Compressors, Compound, Philadelphia Engineering Co.'s, 206.  
Air Compressors, Compound, Reavell, The, 153.

Air Compressors, Compound, Schneider and Co.'s, 215.  
Air Compressors, Compound, Schüchtermann and Kremer, 138.  
Air Compressors, Two-stage, Bailey's Köster, 259.  
Air Compressors, Two-stage, The Reavell, 159.  
Air, Cooling of, 16.  
Air Efficiency, 5.  
Air, Horse Power Required to Compress, 26.  
Air, Physical Properties of, 1.  
Air Washer, The Daw, 255.  
Air, Work Required to Compress, 2.  
Alley and MacLellan's Boreas Air Compressor, 176.  
Alley and MacLellan's Sentinel Air Compressor, 182.  
Allis-Chalmers Co.'s Air Compressor Cylinder, 196.

## B

Bailey, W. H. and Co., "Koster" Air Compressors, 257, 276.  
Berlin Technical High School: Experiments on Express Valves, 279.  
Bessemer Blowing Engines, 114.  
Bessemer Blowing Engines: Breitfeld, Danek, and Co., 116.  
Bessemer Blowing Engines: Kölnische Maschinenbau-Actien-Gesellschaft, 116.  
Bessemer Blowing Engines: Schneider and Co.'s, 120.  
Blast Furnace Blowing Engines, Efficiency of, 111.  
Blowing Engines, 44.  
Blowing Engines, Bessemer, 114.  
Blowing Engines, Blast Furnace:—  
Breitfeld, Danek, and Co., 54, 80.  
Efficiency of, 111.  
Elsädischen Maschinenbau-Gesellschaft, 98.  
Friedrich-Wilhelm Hütte, 78.  
Gutehoffnungshütte, 74.  
Kölnische Maschinenbau-Actien-Gesellschaft, 109.  
Lang, 44.  
Sächsischen Maschinenfabrik, 61.  
Schneider and Co., 67.

Blowing Engine, Compound :—  
 Davy Bros., 101, 103.  
 Lillieshall Co., 99.  
 Boreas Air Compressor, 176.  
 Borsig Experimental Compressor with  
 Stumpf Valves, 276-285.  
 Breitfeld, Danek, and Co. :—  
 Blast Furnace Blowing Engine, 54, 80.  
 Blast Furnace Blowing Engine, Test  
 of, 60.  
 Cross-compound Two-stage Com-  
 pressor, 232.  
 Diagrams from Bessemer Blowing  
 Engines, 116.  
 Brotherhood Air Compressor, 178.

## C

Central Power Station, Paris, Test of a  
 Riedler Compressor at, 33.  
 Chicago Pneumatic Tool Co.'s Com-  
 pressor, Test of, 33.  
 Cincinnati Gear Compressor, Indicator  
 Cards from, 231.  
 Clearance, Effect of, 7.  
 Compound Air Compressors, 18.  
 Compound Blowing Engine :—  
 Davy Bros., 101, 103.  
 Lillieshall Co., 99.  
 Compression: Quantity of Heat that  
 must be Withdrawn, 13.  
 Compression, Rise of Temperature  
 during, 13.  
 Compression Curve, Exponent of, 17.  
 Cooling of Air, 16.  
 Corliss Valve, Glandless, Hughes and  
 Lancaster's, 224.  
 Crewe and Davy's Radial Trip Gear, 114.  
 Cylinder Air Compressor, by Allis-  
 Chalmers Co., 196.  
 Cylinders, Ratios of, 24.

## D

Davey, Paxman, and Co.'s Air Com-  
 pressor Valves, 146.  
 Davy Bros.' Compound Blast Furnace  
 Blowing Engine, 101, 103.  
 Daw Air Compressor, 245.  
 Daw Air Compressor, Test of, 251.  
 Daw Air Washer, 255.  
 Daw Discharge Valve, 246.  
 Daw Governor, 251.  
 Daw Inlet Valve, 246.  
 Delivery Valves: Guttehoffnungshutte,  
 Oberhausen a. d. Ruhr, 70, 167.  
 Duncan, Stewart, and Co.'s Vertical  
 Compound Air Compressor, 132.

## E

Effect of Clearance, 7.  
 Efficiencies, Total and Volumetric, 5.  
 Efficiency, Air, 5.  
 Efficiency of Blast Furnace Blowing  
 Engines, 111.  
 Elsädsischen Maschinenbau-Gesellschaft  
 Vertical Blast Furnace Blowing En-  
 gine, 98.  
 Elwell and Son's High Pressure Air  
 Compressor, 191.  
 Equalisation of Pressure at Both Sides  
 of the Piston at the End of Stroke, 10,  
 222.  
 Equalisation of Pressure, Valves for Pro-  
 ducing, 39.  
 Equalisation of Pressure, Work done per  
 Stroke with, 12.  
 Experiments on Express Valves, 279.  
 Experiments with Compressors, 31.  
 Exponent of Compression Curve, 17.

## F

Francois: Air Compressor, 214.  
 Fraser and Chalmer's King Riedler  
 Compressor at the Powell Duffryn  
 Collieries, 197.  
 Friedrich-Wilhelms Hutte :—  
 Blast Furnace Blowing Engine, 78.  
 Suction and Delivery Valves, 125.

## G

Gas Engine and Blowing Cylinder, Kort-  
 ing Double-acting, constructed by the  
 Siegerner Maschinenbau-Actien-Gesell-  
 schaft, 84.  
 Governor, Air and Speed, Whitmore's,  
 203.  
 Governor of Schneider Blowing Engine,  
 69.  
 Governor, The Daw Automatic, 251.  
 Goodwin's Test of the Daw Air Washer,  
 256.  
 Guttehoffnungshütte Delivery Valves, 70,  
 167.  
 Guttehoffnungshütte Blast Furnace Blow-  
 ing Engine, 74.  
 Guttermuth's Spring Clack Valves, 170.

## H

Heat to be Withdrawn during Com-  
 pression, 12.  
 High-pressure Air Compressor, Elwell  
 and Son's, 191.  
 Horse Power Required to Compress Air.  
 Table, 26.

Hughes and Lancaster's Glandless Corliss Valve, 224.  
Humbolt Air Compressor with Gutter-mouth Valves, 172.

## I

Indicator Diagram from Tilghman's Patent Sand Blast Co.'s Compressor, 15.  
Ingersoll-Sergeant Compressor, 143.

## K

Kennedy's Inlet Valve, 100.  
King-Riedler Compressor, 197.  
Kolnische Maschinenbau-Actien Gesellschaft Blast Furnace Blowing Engine, 109.  
Kolnische Maschinenbau-Actien Gesellschaft Bessemer Blowing Engine, 116.  
Korting Double-acting Gas Engine and Blowing Cylinder, constructed by the Siegener Maschinenbau-Actien-Gesellschaft, 84.  
Koster Air Compressors, 257, 276.  
Koster Piston Valve Gear, 261.

## L

Lang Blast Furnace Blowing Engine, 44.  
Lilleshall Co., Compound Blowing Engine, 99.  
Loss of Pressure in Pipes, 27.

## M

Matthewson's Valves, 128.  
Mechanically-controlled Valves for Air Compressors, Philadelphia Engineering Co.'s, 209, 211.  
Mechanically-controlled Valves for Air Compressors, Schneider and Co.'s, 215.

## O

Offenbach Power Station, Test of a Straad Compressor at, 32.

## P

Philadelphia Engineering Co.'s Compound Air Compressor with Mechanically-controlled Valves, 206.  
Physical Properties of Air, 1.  
Pipes, Loss of Pressure in, 27.  
Powell-Duffryn Colliery, King Riedler Compressor at, 197.

Pressure, Equalisation of, Valves for Producing, 39.  
Pressure, Equalisation of, Work Done per Stroke with, 12.  
Pressure, Loss of, in Pipes, 27.  
Pressure on both Sides of Piston at End of Stroke, Equalisation of, 10.  
Properties of Air, Physical, 1.

## R

Ratios of Cylinders, 24.  
Reavell Air Compressor, The, 156.  
Reavell Compound Compressor, 153.  
Reavell Two-stage Compressors, 159.  
Reumaux Compressor, Test of, 31.  
Reynold's Discharge Valves, 100.  
Richardson, Westgarth, and Co.'s Air Compressor, 222.  
Riedler Compressor, Test of, 33.  
Riedler-Stumpf Discharge Valves, 84, 85.  
Riedler Valves, 201.

## S

Sächsischen Maschinenfabrik, Blast Furnace Blowing Engine, 61.  
Schäffer and Budenberg's Air Compressor, 134.  
Schneider and Co.'s Air Compressor with Mechanically-controlled Valves, 215.  
Schneider and Co.'s Bessemer Blowing Engine, 120.  
Schneider and Co.'s Blast Furnace Blowing Engine, 67.  
Schneider and Co.'s Blast Furnace Blowing Engine Governor, 69, 70.  
Schneider and Co.'s Valves, 122, 215.  
Schüchtermann and Kremer's Compound Air Compressor, 138.  
"Sentinel" Air Compressor, 182.  
"Sentinel Junior" Air Compressor, 190.  
Siegener Maschinenbau Actien Gesellschaft, Korting Double-acting Gas Engine and Blowing Cylinder, 84.  
St. Pankraz Mine, Brietfeld Two-stage Cross-compound Compressor at, 239.  
Straad Compressor, Test of, 32.  
Stumpf's "Express" Valves, 276.

## T

Table of Horse Power Required to Compress Air, 25.  
Temperature during Compression, Rise of, 13.  
Test of Breittfeld Danek and Co.'s Blowing Engines, 60.  
Test of a Daw Cross-compound Two-stage Compressor, 251.

Test for a Koster Two-stage Belt-driven Air Compressor, 259.  
 Test of a Reumaux Compressor, 31.  
 Test of a Riedler Compressor, 33.  
 Test of a Straad Compressor, 32.  
 Test of a Two-stage Compressor, by the Chicago Pneumatic Tool Co., 33.  
 Tilghman's Patent Sand Blast Co.'s Compressor, Indicator Diagram from, 15.  
 Tilghman's Patent Sand Blast Co.'s Air Compressor, 128.  
 Total and Volumetric Efficiencies, 5.

## V

Valve Diagrams, Stumpf "Express," 282.  
 Valves :

Blowing Engines, Best number of, 52.  
 Davey, Paxman, and Co.'s, 146.  
 Daw Inlet and Discharge, 246.  
 Discharge, The Daw, 246.  
 Express, 276.  
 Friedrich-Wilhelm-Hütte, 125.  
 Glandless Corliss, Hughes and Lancaster's, 224.

Valves—*continued.*

Guttermuth's, 17.  
 Gutehoffnungshütte, 70, 167.  
 Inlet, The Daw, 246.  
 Kennedy's, 100.  
 Köster, 261, 263.  
 Matthewson's, 128.  
 Riedler, 201.  
 Riedler-Stumpf, S4, 85.  
 Reynold's, 100.  
 Schneider and Co.'s Mechanically-operated, 122.  
 Stumpf Express, 276.  
 Valves for Producing Equalisation of Pressure at End of Stroke, 39, 222.

## W

Whitmore Air and Speed Governor, 203.  
 Work Done per Stroke with Equalisation of Pressure at End of Stroke, 12.  
 Work Required to Compress Air, 2.  
 Worthington Pump Co.'s Air Compressor 228.











THIS BOOK IS DUE ON THE LAST DATE  
STAMPED BELOW

AN INITIAL FINE OF 25 CENTS

WILL BE ASSESSED FOR FAILURE TO RETURN  
THIS BOOK ON THE DATE DUE. THE PENALTY  
WILL INCREASE TO 50 CENTS ON THE FOURTH  
DAY AND TO \$1.00 ON THE SEVENTH DAY  
OVERDUE.

SEP 01 1940

SEP 22 1940  
OCT 9 1941

JAN 4 1946

JAN 19 1946

15 Nov '48 EC

2 Apr '49 BC

26 Oct '49 JA

1 Dec '49 JLS

1 Dec '50 H J

4 Nov '58 BB

REC'D LD

5 21 1958

YB 16086

187724

TJ  
950  
I6

**THE UNIVERSITY OF CALIFORNIA LIBRARY**

