

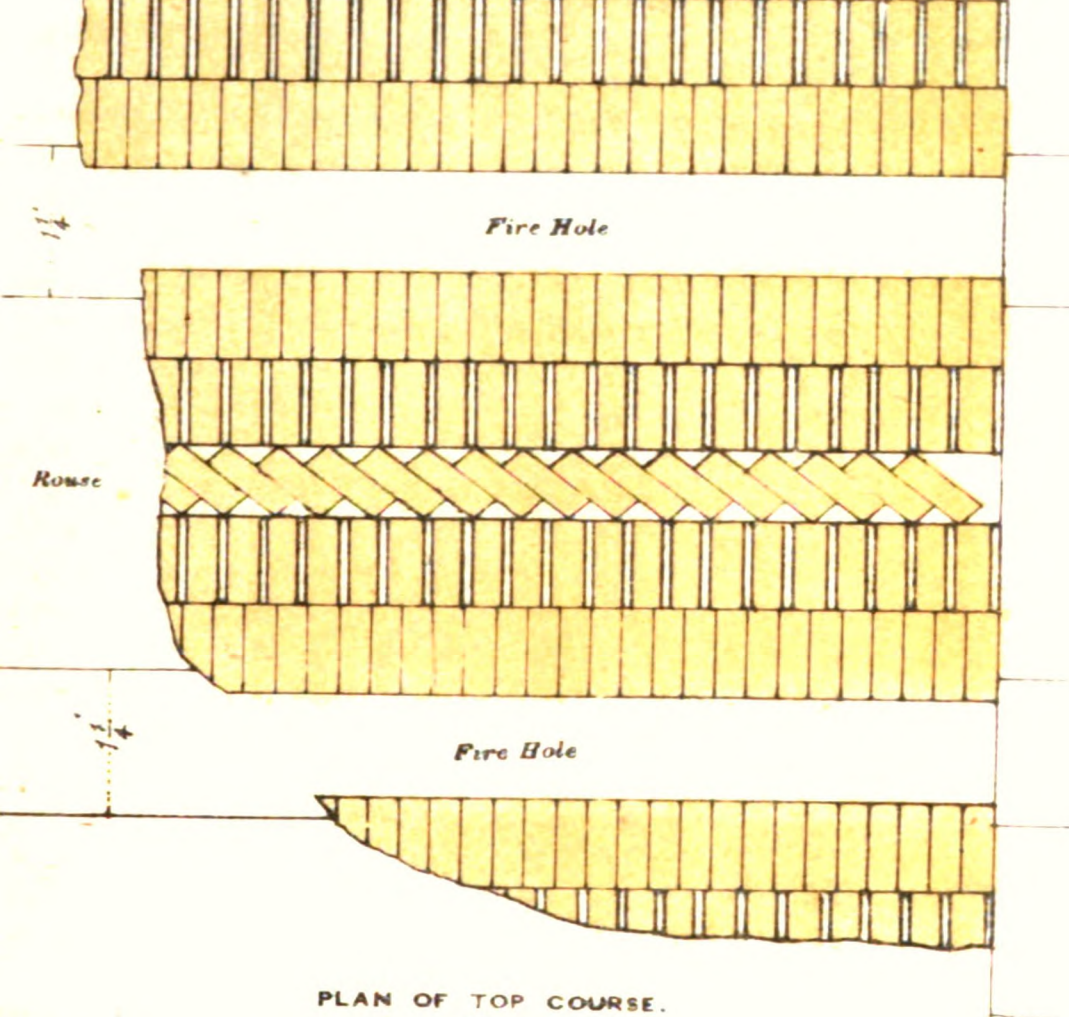
---

This is a reproduction of a library book that was digitized by Google as part of an ongoing effort to preserve the information in books and make it universally accessible.

Google™ books

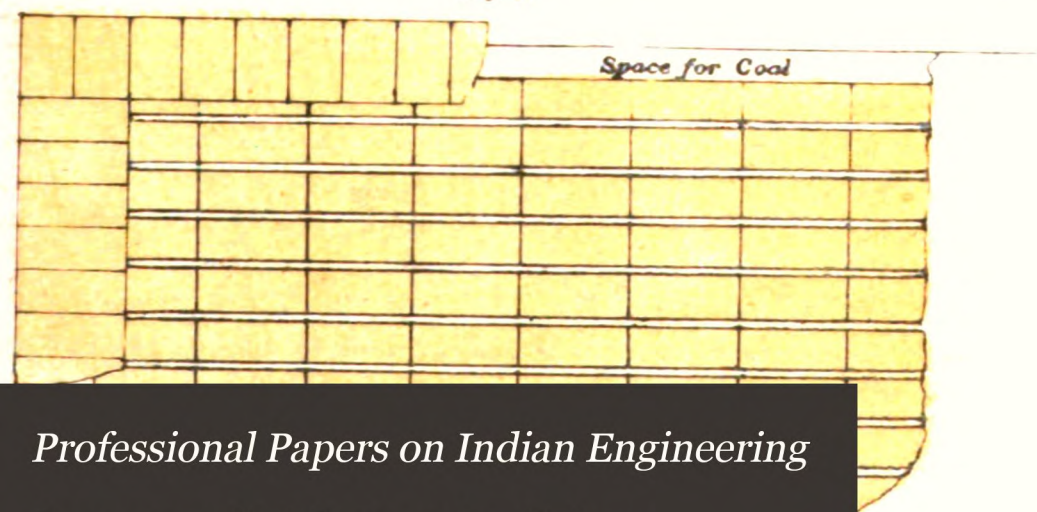
<https://books.google.com>

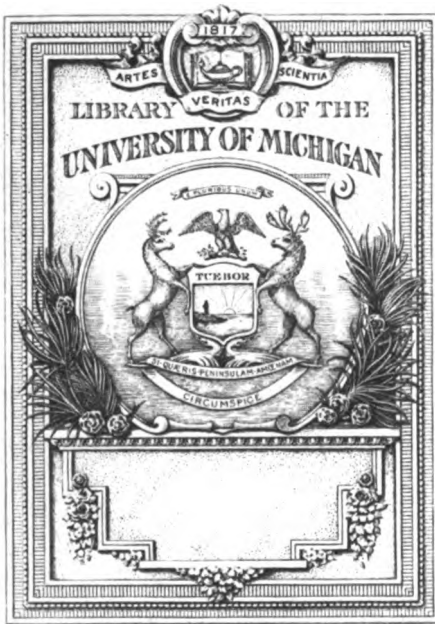




PLAN OF TOP COURSE.

*Fig. 5.*





TA  
1  
.P963





**PROFESSIONAL PAPERS**

ON

**INDIAN ENGINEERING:**

---

[SECOND SERIES.]

---

EDITED BY

**MAJOR A. M. LANG, R.E.,**

**PRINCIPAL, THOMASON C. P. COLLEGE, ROORKEE.**

---

**VOL. III.**

---

**ROORKEE:**

**PRINTED AND PUBLISHED AT THE THOMASON COLLEGE PRESS.**

**CALCUTTA: THACKER, SPINK & Co. BOMBAY: THACKER, VINING & Co.**

**MADRAS: GANTZ, BROTHERS. LONDON: H. & F. N. SPON & Co.**

**1874.**

*[All rights reserved by the Secretary of State for India in Council.]*

**JAMES JOHNSTON, SUPERINTENDENT.**

Ref-sths  
12-14-40  
41779

## PREFACE TO VOL. III.

---

THE "Second Series" of the Professional Papers of Indian Engineering has now reached the end of a Third Annual Volume. Ten volumes of these papers, commenced in 1863, have now been published, and embody a large collection of interesting Records of Indian Engineering during the past eleven years.

The volume just concluded contains thirty-nine articles on a variety of subjects in the several branches of Engineering. Thus four relate to works connected with Irrigation; and the same number to Railway questions: three are descriptive of Buildings: two refer to Harbour Works: seven discuss Well Sinking and Apparatus connected with that operation: seven enter into details of Construction, Arches, Dams, Walls, Roofs, &c.: two are descriptive of Surveying and Mathematical Instruments: two treat of Cement Manufacture and Testing: and one article is devoted to each of the following subjects:—Artesian Wells, Earthwork, Tiles, Brickmaking, Trucks, Waterway of Bridges, Meteorology, and Forestry.

Thus the present volume is more varied in its contents than perhaps most of its predecessors: and contains one or two articles of more than ordinary interest. Among many interesting papers it is difficult to particularize those of the greatest value: but the following may be noted as treating of recent important works or manufactures well worth the study of the profession in India.

The Head-works of the New Agra Canal present some very important novelties in construction, the experience gained from which may cause considerable modifications in the practice of building weirs, and perhaps other structures, in the sandy beds of Indian rivers: these works are well described in an interesting article by Major Helsham Jones, R.E. Major Falconnet, R.E., has furnished an exhaustive paper on the Manufacture of the superior description of Bricks and Tiles now used for the Military Buildings at Allahabad,—a paper which should prove of great practical value to Engineers in this Country. The extensive use of well-foundations for bridges and other important structures in this Country, calls forth the inventive talents of many officers engaged on such works, and numerous descriptions of new excavators and dredgers have appeared in the pages of this periodical: the volume now issued introducing to notice seven new instruments of this class.

The first number of the new volume,—forming No. 15 of this Second Series,—will be issued in January next: the terms of Subscription, payment for single numbers, &c., remaining unaltered.

A. M. L.

# INDEX TO VOL. III.

[SECOND SERIES.]

---

	PAGE.
<b>Agra Canal, The.</b> By Major H. Helsham Jones, R.E., ... ..	302
<b>Artesian Boring at Umballa.</b> By Major E. T. Thackeray, R.E., Exec. Engineer, ... ..	117
<b>Barometric Readings at High Stations to Sea Level, Reduction of.</b> By Capt. Allan Cunningham, R.E., Hony. Fellow of King's Col- lege, London, ... ..	133
<b>Brick and Tile Manufacture at Allahabad.</b> By Major G. P. deP. Falconnet, R.E., Supdg. Engineer, ... ..	146
<b>Brickwork, Hollow Walls of.</b> By Major C. S. Thomason, R.E., Supdg. Engineer, 1st Circle, Provincial Works, N. W. Provinces,	413
<b>Bridges, Waterway of, in India.</b> By C. O. Burge, Esq., Assoc Inst. C.E., Resident Engineer, Madras Railway, ... ..	237
<b>Canals, Inundation, Multán, Notes on the.</b> By E. A. Sibold, Esq., Exec. Engineer, Sirhind Canal, ... .. 39 and	351
<b>Cement Testing Machine, Michele's.</b> Communicated by J. Mac- donald, Esq., ... ..	67
<b>Chief Court at Lahore.</b> By Rai Kunhya Lal, Assoc. Inst. C.E., Exec. Engineer, ... ..	223
<b>Civil Buildings, Lahore.</b> By Rai Kunhya Lal, Assoc. Inst. C.E., Exec. Engineer, ... ..	54
<b>Clay-cutter, Bull's fixed.</b> By W. Bull, Esq., Resident Engineer, Oudh and Rohilkund Railway, ... ..	143
<b>Clay-Scoop and Sub-Aqueous Excavator, Naylor's.</b> By R. DeG. Naylor, Esq., 1st Asst. Supdt. of Telegraphs, ... ..	19
<b>Clay Under-Cutter for Well Sinking.</b> By Edward Byrne, Esq., M. Inst. C.E., Exec. Engineer, ... ..	83
<b>Concrete Blocks for Manora Breakwater.</b> By W. H. Price, Esq., M. Inst. C.E., Superintendent, Kurrachee Harbor Works, ...	398

	PAGE.
Dredgers, Pitt's proposed. By Sergt. W. H. Pitt, R.E., Overseer, P. W. D., Bombay, ... ..	405
Dredger, Ratchet, Molesworth's. By G. L. Molesworth, Esq., Consulting Engineer to the Government of India for State Railways, ... ..	369
Earthwork in Sind. By W. H. Price, Esq., M. Inst., C.E., Superintendent, Kurrachee Harbor Works, ... ..	48
Flanges, On Angle-iron. By Capt. Allan Cunningham, R.E., Hony. Fellow of King's College, London, ... ..	415
Flat Roofing, Scantlings and Cost of. By ( <i>the late</i> ) E. L. Asher, Esq., Exec. Engineer, ... ..	280
Garden Lodges and Toll-House, Ootacamund, ( <i>with Photographs</i> ). By Capt. J. L. L. Morant, R.E., Assoc. Inst. C.E., F.R.G.S.,	1
Girder-Bridges for Metre Railways, Designs of. . By C. H. G. Jenkinson, Esq., Assoc. Inst. C.E., Assoc. King's College, London, and Assist. Engineer, Western Rajpootana (State) Railway,	174
Grating for stopping Floating Logs near head of Ganges Canal, Proposed. By J. S. Beresford, Esq., C.E., Exec. Engineer, ...	372
Harbor Works, Kurrachee, Memoir of. By W. H. Price, Esq., M. Inst. C.E., Superintendent of the Harbor Improvement Works,	186
Integrometer, On the. Translated by Capt. Allan Cunningham, R.E., Hony. Fellow of King's College, London, ... ..	8
Levelling Staff, The "Milne" Pattern of. By C. C. Sullivan, Esq., Head Master, Thomason College, ... ..	242
Levels, and of Everest and Transit Theodolites, Adjustment of. By Capt. Allan Cunningham, R.E., Hony. Fellow of King's College, London, ... ..	294
Limestones, Mysore. By Lieut.-Col. R. H. Sankey, R.E., Chief Engineer, Mysore, ... ..	26
Lock Tiles, Cantwell's, ... ..	343
Masonry Dams for Reservoirs. By G. L. Molesworth, Esq., Consulting Engineer to the Government of India for State Railways, ... ..	394
Metre Gauge for State Railways in India, On the Adoption of the. By C. H. G. Jenkinson, Esq., Assoc. Inst. C.E., Assoc. King's College, London, and Assist. Engineer, Western Rajpootana (State) Railway, ... ..	105

	PAGE.
Oblique Arches, On the Construction of. By A. C. Lawford, Esq., Assoc. Inst. C.E., Exec. Engineer, D. P. W., Madras Presidency,	377
Rafters and Purlins. By Capt. Allan Cunningham, R.E., Hony. Fellow of King's College, London, ... ..	245
Rail Joints, Experiments on. By Edward Byrne, Esq., M. Inst. C.E., Exec. Engineer, ... ..	85
Railway on the Ladder System, The Rigi. By Major T. F. Dow- den, R.E., ... ..	327
Sleeper Slides in Jounsar Forests. By C. Bagshawe, Esq., Assist. Conservator, Jounsar Forests, ... ..	262
Soils and Waters, Impurities of. Translated by A. Nielly, Esq., Assistant Engineer, ... ..	57
Trucks and Wheelbarrows, Improved types of. By Capt. J. L. L. Morant, R.E., Assoc. Inst. C.E., F.R.G.S., ... ..	290
Well Foundations and Well Sinking. By Edward Byrne, Esq., M. Inst. C.E., Exec. Engineer, ... ..	70
Well Foundations, Review of Paper (No. CVII.) on. By Capt. Allan Cunningham, R.E., Hony. Fellow of King's College, London,	128

---

## LIST OF PLATES.

---

### PHOTOGRAPHS.

Ootacamund Garden Lodges and Toll-House ( <i>Frontispiece</i> ), ...	1
--	---

### LITHOGRAPHS.

Ootacamund Garden Lodges and Toll-House. Entrance Lodges, Iron Gate and Railings. Ground Plan and Front Elevation (2)— Toll-House and Gate at entrance to Town. Ground Plan, Front and Side Elevations (2)—Details of Garden Gate Pillars, &c. Side Elevation and Section of Roof of Garden Lodge, Section and Elevation of Garden Rails, Top Plan and Elevation of Side Pillar Cap, Top Plan and Elevation of Centre Pillar Cap, Section and Elevation of Exterior Cornice (4)—Toll-House and Gate at entrance to Town. Enlarged Elevation of Gate hinge, Elevations of Gate, Chimney, Toll Board Box, Elevations and Sections of Cornice, and Console to Doors and Windows, Section of Roof,	4
--	---



	PAGE.
Naylor's Clay-Scoop and Sub-Aqueous Excavator. Showing the from when ascending and descending, ... ..	24
Notes on the Multán Inundation Canals. General Map of Coun- try (40)—Cross Section of Sutlej Valley on right bank, Working and sudden change of deep stream, Length of private water- course (42)—Sketch Map of the Upper Chenab Canals (358)— Plan, Longitudinal Section and Section of Syphons, Plan of Regulator (366) Longitudinal and Cross Section of Pier, Bridge, 1st mile, Shahpore Canal; Half Plan and Section of Luftabad Road Bridge, Suraj-Miani Feeder; Plan of Tail Fall, Improved Plan and Section of Fall, up-stream Elevation and Cross Sec- tion of Waste Weir, ... ..	368
Civil Buildings, Lahore. Front Elevation and Sections, and part of Longitudinal Section of Verandah (54)—Plan (54)—Part of enlarged Elevation of Cornice with Bracket, Section of Truss, and Doric order for upper story, ... ..	54
Well Foundations and Well Sinking. Explanatory type diagram of Resisting and Overturning powers, ... ..	72
Clay Under-cutter for Well Sinking. Cutter for the removal of hard material from beneath a well curb, .... ..	84
Experiments on Rail joints. Old Permanent Way of Cawnpore Branch, Oudh and Rohilkund Line. Section and Sectional Ele- vation (86)—Rails of New Permanent Way, 60 lbs. per lineal yard, joined with Ibbotson's Steel Clip. Joint of 36 lb. Rail, Old Permanent Way, Lucknow and Cawnpore Branch, 60 lb. Rail, New Permanent Way, joined with Clip, in two parts, similar to that of Old Permanent Way (92)—New Permanent Way of Cawnpore Branch, Oudh and Rohilkund Line. Cross Sections of Sleeper, Sand and Ballast, Plan and Elevation of Chair, and Longitudinal Section of Sleeper, ... ..	94
Artesian Boring at Umballa. Section showing the lengths and dimensions of the Pipes and point of fracture of 3-inch tubes (122)—Fish head with two steel cutters for detaching and lifting up 3-inch tubes, Section through the boring, showing screw- jacks with clamps for lifting the rods (124)—Plans and Eleva- tions of Clamp for holding the rods and pipes, Section through the boring showing Clamps for holding rods and 3-inch pipes,	124

	PAGE.
Bull's fixed Clay-Cutter. Plan, Section and Elevation of an eight foot curb, ... ..	144
Brick and Tile Manufacture at Allahabad. Plans of courses, Nos. 3, 4, 8, pocket course or No. 12, 13 to 23, and top course (156)—Part Longitudinal Section of Kiln (156)—Cross Sections of Tum Tum, part of Kiln (156)—Plan, Elevation, Section and End Elevation of Kiln (156)—Elevation of double layer of tiles (164)—Section through Pug-mill, Cross Section of Tile shed, Side Elevation, Section and Isometrical Projection of Clay Cutting Bow, Plan, Longitudinal Section and Isometrical Projection of Moulding Table with Water box, Sand box and Kneading board (164)—Plan, Longitudinal Section and Isometrical Projection of body of Flat Tile Mould; Plan, Section and Isometrical Projection of Fork of Flat Tile Mould (164)—Plans, Sections and Isometrical Projections of Dressing Block, Strike, Dresser and Flat Tile; Side Elevation of Dressing Knife (164)—Plan and Isometrical Projection of Body of Mould for Half Round Tile, Plan, Longitudinal Section, and Isometrical Projection of Fork Half Round Tile Mould; Elevation and Isometrical Projection of Strike for giving a bevelled edge, Dressing Knife for Half Round, and Semi-hexagonal Tile (172)—Plan, Longitudinal Section and Isometrical Projection of Dressing Block, hinged to table, Plan and Isometrical Projection of Dresser for Half Round Tile, Isometrical Projections of Half Round Tile with two buttons turned up side down, and mould for Half Round Tile (172)—Plan, Cross and Longitudinal Sections and Isometrical Projection of Half Round Tile; Plan, Cross Section, and Isometrical Projection of Fork for Half Round Tile (172)—Plan and Isometrical Projection of Mould for Semi-hexagonal Tile, Plan and Isometrical Projection of frame used for moulding Semi-hexagon Tile (172)—Plan, Longitudinal Section and Isometrical Projection of Mould for Semi-hexagon Tile, showing method of securing it; Lever for Press used with Semi-hexagon Tile (172)—Plan, Cross Section and Isometrical Projection of Fork, Plan and Isometrical Projection of Dresser; Plan, Cross Section and Isometrical Projection of Dressing Block (172)—Plan, Cross Section and Isometrical Projection of Semi-hexagon Tile, Isometrical Pro-	

	PAGE.
jections of the different Semi-hexagon Tiles, Plan, Cross Section, Side Elevation and Isometrical Projection of the Semi-hexagon Tile (172)—Plan, Cross Section and Isometrical Projection of Body of Mould for Ridge Tile ; Plan, Cross and Longitudinal Section, End view, and Isometrical Projection of Fork for Ridge Tile Mould ; Plan, Cross Section and Isometrical Projection of Drying Block for Ridge Tile (172)—Elevation, Cross Section and Isometrical Projection of Strike for Ridge Tile, Clay Cutter ; Plan, Longitudinal and Cross Sections and Isometrical Projection of Body of Mould for Ventilating Ridge Pipe, Plan and Isometrical Projection of Fork for Ventilating Ridge Pipe Mould, Isometrical view, Mould complete (172)—Plan, Cross Section and Isometrical Projection of Block for Ventilating Ridge Tile ; Plan, Longitudinal Section and Isometrical Projection of Ventilating Ridge Tile (172)—Plan, Section, Longitudinal Section and Isometrical Projection of Mould for Half Round Ridge Tile ; Plan, Elevation and Isometrical Projection of Strike for Half Round Ridge Tile ; Plan, Longitudinal Section and Isometrical Projection of Half Round Ridge Tile (172)—Plans, Cross Sections and Isometrical Projections of Body and Fork of Mould for Hip Tile (172)—Plan, Cross Section and Isometrical Projection of Block for Hip Tile ; Plan, Cross Section and Isometrical Projection of Hip Tile, Projection of the Hip Cap, Block for drying Hip Cap on, ...	172
Examples of Wrought-iron Girder Bridges. On the Design of Wrought-iron Girder Bridges for Metre Railways, ...	178
Memoir of Kurrachee Harbor Works. Plan of Kurrachee Harbor, December 1873, ... ..	186
Chief Court at Lahore. Front Elevation (224)—End Elevation (226)—Cross Section (228)—Longitudinal Section (230)—Out-houses ; Ground Plan, Elevation and Section of Stalls, Ground Plans and Elevations of Godown and Police Guard, Suitor's Shed and Servant's houses (232)—Plan, ... ..	234
Levelling Staves. Gravatt's, Roorkee, and Conybeare's Staves, showing the different methods of graduation (244)—G. T. Survey Staff (244)—The "Milne" Pattern, and Triangular Pattern as used in Rajpootana, ... ..	244
Sleeper Slides in Jounsar Forests. Mundhol Slide, Details of Tres-	

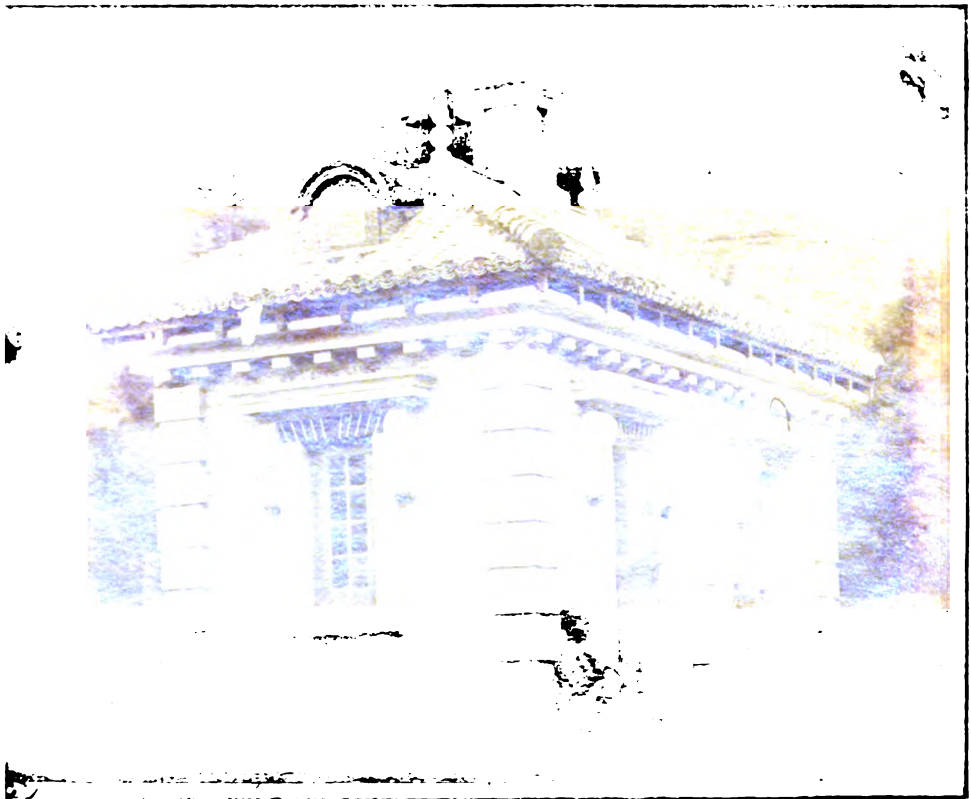
	PAGE.
ties, Plan, Side and End Elevations of Truck (268)—Slides and Tramway at Lambaiach, Plans and Cross Sections of Roadway, and slide uncovered, Plan and Elevation of Truck, showing how sleepers are carried, Method of joining bottoms, Elevation and Section, ... ..	276
Scantlings and Cost of Flat Roofing. Plan, Elevation and Section of Standard Goordaspore Queen-Trussed Beam (original pattern), Elevation and Section of Standard Truss (286)—Plan and Longitudinal Section (improved pattern), Detail of tie-bar head, Plan, and Section through centre of Scarf, showing hoop and wedging,	286
Improved Types of Trucks and Wheel-Barrow. Top and Bottom Plan, Front and Longitudinal Elevations of a Wrought-iron Wheel-barrow (292)—Top and Bottom Plan, Longitudinal and Rear Elevation and Cross Section of a Stoue Truck (292)—Do. with round iron bars, ... ..	292
Adjustment of Levels, and of Everest and Transit Theodolites, ...	296
The Agra Canal. Sketch of course of Agra Canal, with course of Rajbuhas (302)—Okhla Weir Works; Block Plan (306)—Head Works Okhla Weir, left wing-wall; Plan, Elevation and Sections; Plan, Elevations and Section of Foundations (306)—Record Plan of Foundation of Under-slucies; Elevation and Section of Blocks, down-stream side; Plan and Section of Foundation, End Elevation of Blocks (308)—Plan, Sections, Longitudinal and Transverse Sections and up- and down-stream Elevations, Enlarged plan of pier head, (308)—Plans, Sections and Elevation of Head Slucies; Plan, Longitudinal and Transverse Sections of Foundation above floor Canal, Elevation from river (308)—Record Plan Okhla Lock; Plan, Sections and Elevation (308)—Sections of Okhla Weir (310)—Old course of Jumna showing the Island Cuts (314)—Plan of Canal from Okhla to 8th mile, showing Reservoirs (320)—Chajunagar Weir and Lock; Plan, Sections and Sectional Elevation, ... ..	324
The Rigi Railway on the Ladder System. Ground Plan, Transverse and Longitudinal Sections of Railroad, Ground Plan and Side Elevation of Turntable (328)—Wrought-iron Plate Bridge over the Schnurtobel. Ground Plan, Side Elevation and Transverse Section of Bridge, Longitudinal Section of the Bridge Railing, Elevation of large and small girder piers (330)—Elevation of	

	PAGE.
Locomotive, Longitudinal and Transverse Sections of Ladder Rails, Driving and back wheel axles. Driving Wheels and Ladder Cogs (330)—Side Elevation and Longitudinal and Transverse Sections of Passenger Carriage, ... ..	332
Molesworth's Ratchet Dredger. Diagrams showing different positions of Dredger (370)—Positions of Ratchet, Pawl, Stop, Lever Arm and Catch (370)—Details of Dredger, ... ..	370
Proposed Grating for stopping Floating Logs near head of Ganges Canal. Plans of Grating complete, and Footway removed, upstream Elevation of Grating (374)—Sections of Grating; when at rest, and position when bringing log to rest, Enlarged Side Elevation of Rocker and Segment, ... ..	374
On the Construction of Oblique Arches. Detailed Drawing of an Oblique Arch, ... ..	380
Masonry Dams for Reservoirs. Sections of different dams compared with sections calculated by Molesworth's formula, ...	394
Concrete Blocks for Manora Breakwater. General Plan (398)—Plan of Block Ground, Longitudinal Elevation, Transverse Section and Elevation of Goliath Traveller and block, Transverse Section and Elevation of Small Traveller (400)—Plan, Front Elevation and Transverse Section of Concrete Mixing Station ... ..	402
Pitt's proposed Dredgers. Half Elevation and Half Longitudinal Section Angur Dredger, Elevation showing position of Posts, Plan and Section of Shutter, Plans of Capstan, Screws opened and closed, bottom of Dredger showing position of cutting bits, half with the bottom covering plate removed, and showing vents closed (406)—Half Elevation of Cylindrical Dredger, showing position of chains, &c., when ready for lowering, Half Longitudinal Section showing interior arrangement of chains, &c., Plans of bottom of Dredger showing doors neatly closed, top of Dredger, and Plan and Elevation of Capstan (408)—Plans, Elevations and Sections of different parts of Boulder Extractor (410)—Rough Sketches showing positions of Cylindrical Dredge during its proposed operation in Well or Block Sinking, also a sketch of Boulder Extractor, as proposed to be applied in the clearing out of a Boulder from a Well, ... ..	410
Hollow Walls of Brickwork, ... ..	414





OOTACAMUND GARDEN LODGES.



No. XCVIII.

OOTACAMUND GARDEN LODGES AND TOLL-HOUSE.

[*Vide* Photographs and *Plate* Nos. I. to IV.]

BY CAPT. J. L. L. MORANT, R.E., *Assoc. Inst. C.E., and F.R.G.S.*

THE Government Botanical Gardens at Ootacamund are placed in a position of great beauty. They lie on a steep declivity which was once a wood or "sholah." The opportunity has been taken in laying them out to make the most of these advantages. Much of the virgin forest has been retained, and the gardens abound in glades, terraces and swards, from whence extensive views of the distant blue hills are obtainable. One of the latest improvements has been to furnish the gardens with entrance lodges and iron gates and rails.

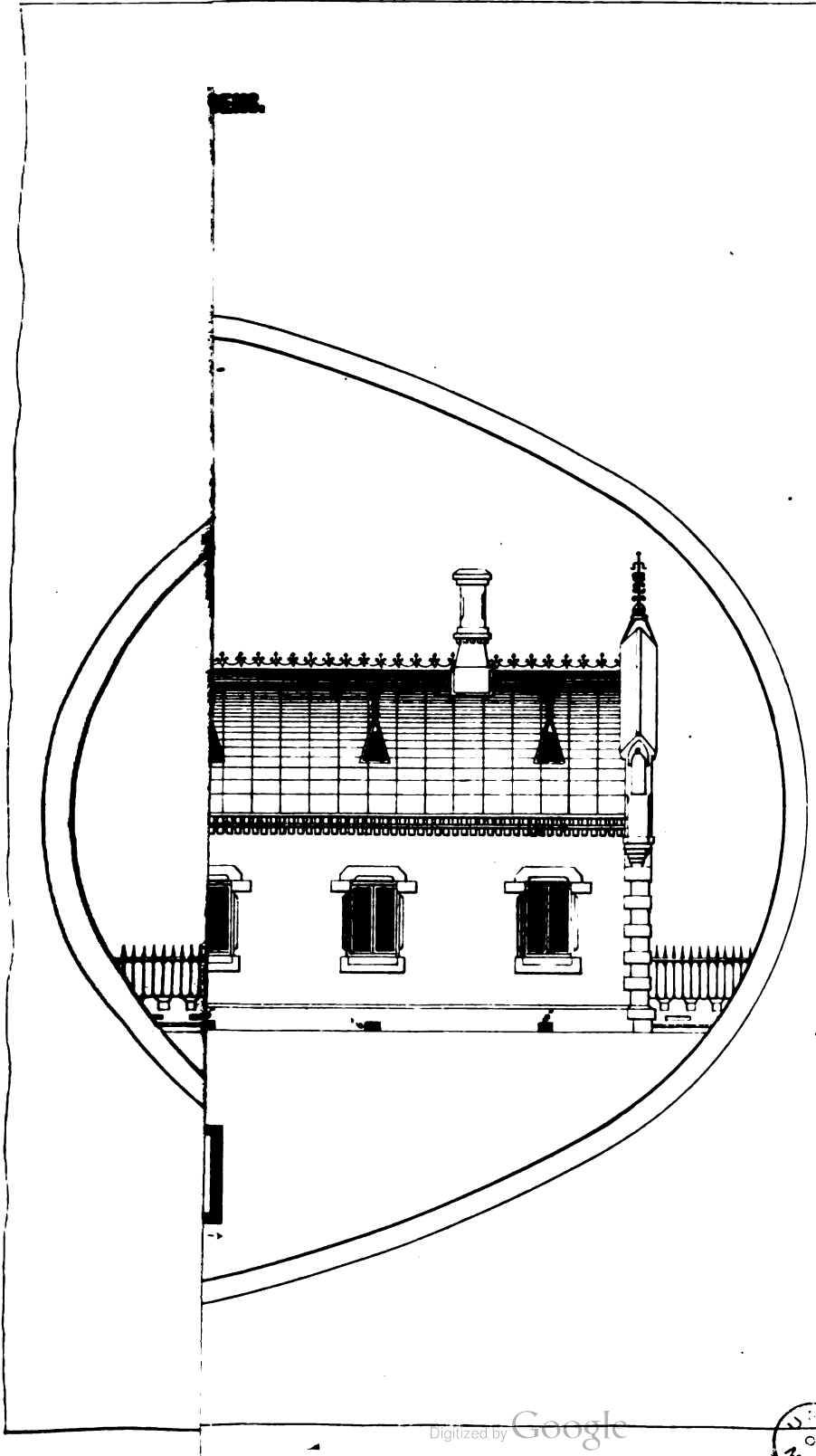
The two lodges, which are exactly similar, each consist of two rooms, one  $17\frac{1}{4} \times 11$  feet, and the other  $9\frac{1}{2} \times 11$  feet. Of the larger rooms, one is for seeds, and the other for herbs; the smaller for an office and for stores, respectively.

These buildings are built of brick and mortar throughout. The basements are plastered and chamfered at top. The angles of the building are strengthened by smooth quoins of brickwork plastered projecting  $\frac{3}{4}$  and  $1\frac{1}{4}$  inch from the naked of the wall. The walls have been built very carefully with colored bricks (yellow and red) forming the patterns shown in the Photograph. All the doors and windows, except those in the gable walls lighting the roof, are square-headed with chamfered jambs. Their sills, labels and socles are of plastered brickwork, painted in imitation of stone. The front and rear walls are topped with a two layered block cornice separated by a thin string; these are formed partly of colored bricks, and partly of plastered brickwork. The coping of the gables, which is of plastered brickwork, painted to imitate stone, is purposely high and massive to protect the roofs from the strong gusty side winds which prevail on this site. They are terminated at the eaves with high projecting



gables, supported by a stepped corbel springing block. Their crest is surmounted with wrought-iron finials resting on a four gablet-faced apex saddle. The steep pitched roofs are simply of corrugated iron laid over teak trusses, and purlins. They are ventilated by louvred dormers, with well inclined glass luffers, to admit a free current of air and a good deal of light, at the same time excluding the rain. The dormers are crested with terminals, and provided with barge boards. The roofs are crested with a wrought-iron ornamental ridging. The floors are of teak wood with under ventilation, and are provided with skirting boards 7 inches high, with hollow and torus moulding at top. The door steps are of plain solid tool-ed granite. The chimney tops are of colored bricks in bands, with bases, plinth, and caps of plastered brickwork painted to imitate stone. The interior of the buildings is of plastered shell lime brought to a fine polish. The iron roof is internally painted with two coats of white oxide of zinc; externally with four coats of a pale blue in horizontal bands of dark and light (*see* Photograph). All the woodwork (which is teak) is oiled internally and painted externally with three coats of Carson's oak paint. These lodges cost Rs. 3,265.

It may be here, perhaps, not out of place to offer a few words about corrugated iron roofs. They should be well bolted together, and to the walls which they cover, otherwise they are very apt to be displaced by the wind. The trusses should be well tied to the walls by long holding bolts  $\frac{3}{8}$ -inch thick, embedded in *mortar* masonry, (never with clay for mortar,) and terminated at their lower ends by broad pieces of iron in the shape of a wind-mill. The purlins should then be bolted to the principal rafters with galvanized iron bolts, and to the gable walls with long wrought-iron bolts, embedded in masonry. The corrugated sheets should then be bolted to the purlins, and should be provided with wooden or wrought-iron battens laid outside and parallel to the purlins, so as to prevent the heads or nuts of the bolts wearing large holes in the iron, by the slight movement to which all the sheets are subject through contraction and expansion. Molesworth says, " sheets should overlap about six inches, and be double riveted at joints. Purlins should be about 6 feet apart." My experience leads me to think that the sheets should not be riveted together. The purlins should be placed where the sheets overlap, and one bolt should fasten together the two sheets to the purlin; one purlin of a little less width being placed between every two of the main ones, to sup-

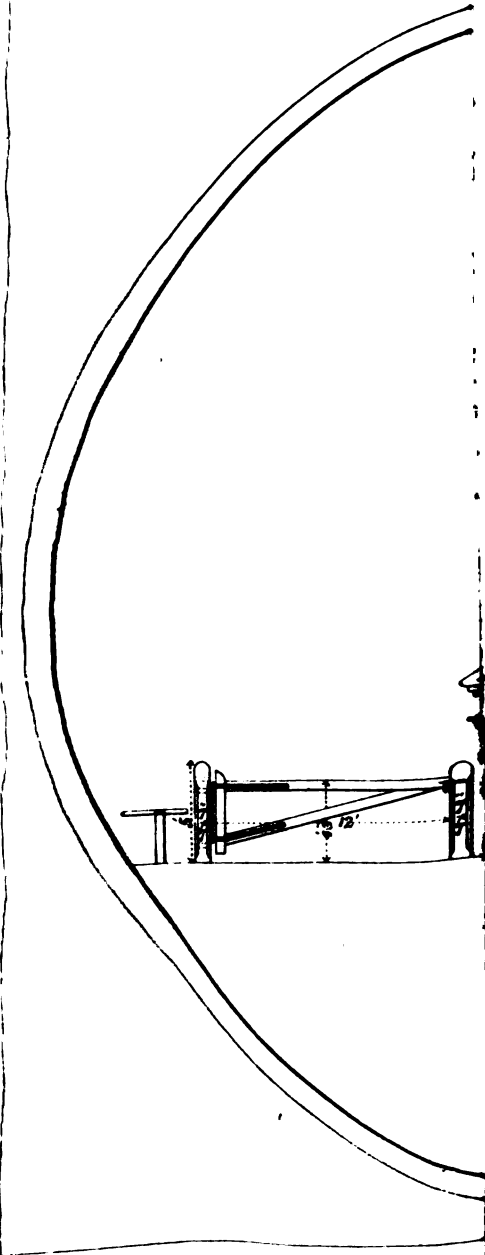


gables, supported by a stepped corbel springing block. Their crest is surmounted with wrought-iron finials resting on a four gablet-faced apex saddle. The steep pitched roofs are simply of corrugated iron laid over teak trusses, and purlins. They are ventilated by louvred dormers, with well inclined glass luffers, to admit a free current of air and a good deal of light, at the same time excluding the rain. The dormers are crested with terminals, and provided with barge boards. The roofs are crested with a wrought-iron ornamental ridging. The floors are of teak wood with under ventilation, and are provided with skirting boards 7 inches high, with hollow and torus moulding at top. The door steps are of plain solid tool-ed granite. The chimney tops are of colored bricks in bands, with bases, plinth, and caps of plastered brickwork painted to imitate stone. The interior of the buildings is of plastered shell lime brought to a fine polish. The iron roof is internally painted with two coats of white oxide of zinc; externally with four coats of a pale blue in horizontal bands of dark and light (*see* Photograph). All the woodwork (which is teak) is oiled internally and painted externally with three coats of Carson's oak paint. These lodges cost Rs. 3,265.

It may be here, perhaps, not out of place to offer a few words about corrugated iron roofs. They should be well bolted together, and to the walls which they cover, otherwise they are very apt to be displaced by the wind. The trusses should be well tied to the walls by long holding bolts  $\frac{3}{4}$ -inch thick, embedded in *mortar* masonry, (never with clay for mortar,) and terminated at their lower ends by broad pieces of iron in the shape of a wind-mill. The purlins should then be bolted to the principal rafters with galvanized iron bolts, and to the gable walls with long wrought-iron bolts, embedded in masonry. The corrugated sheets should then be bolted to the purlins, and should be provided with wooden or wrought-iron battens laid outside and parallel to the purlins, so as to prevent the heads or nuts of the bolts wearing large holes in the iron, by the slight movement to which all the sheets are subject through contraction and expansion. Molesworth says, " sheets should overlap about six inches, and be double riveted at joints. Purlins should be about 6 feet apart." My experience leads me to think that the sheets should not be riveted together. The purlins should be placed where the sheets overlap, and one bolt should fasten together the two sheets to the purlin; one purlin of a little less width being placed between every two of the main ones, to sup-

TOLL HOUSE

10





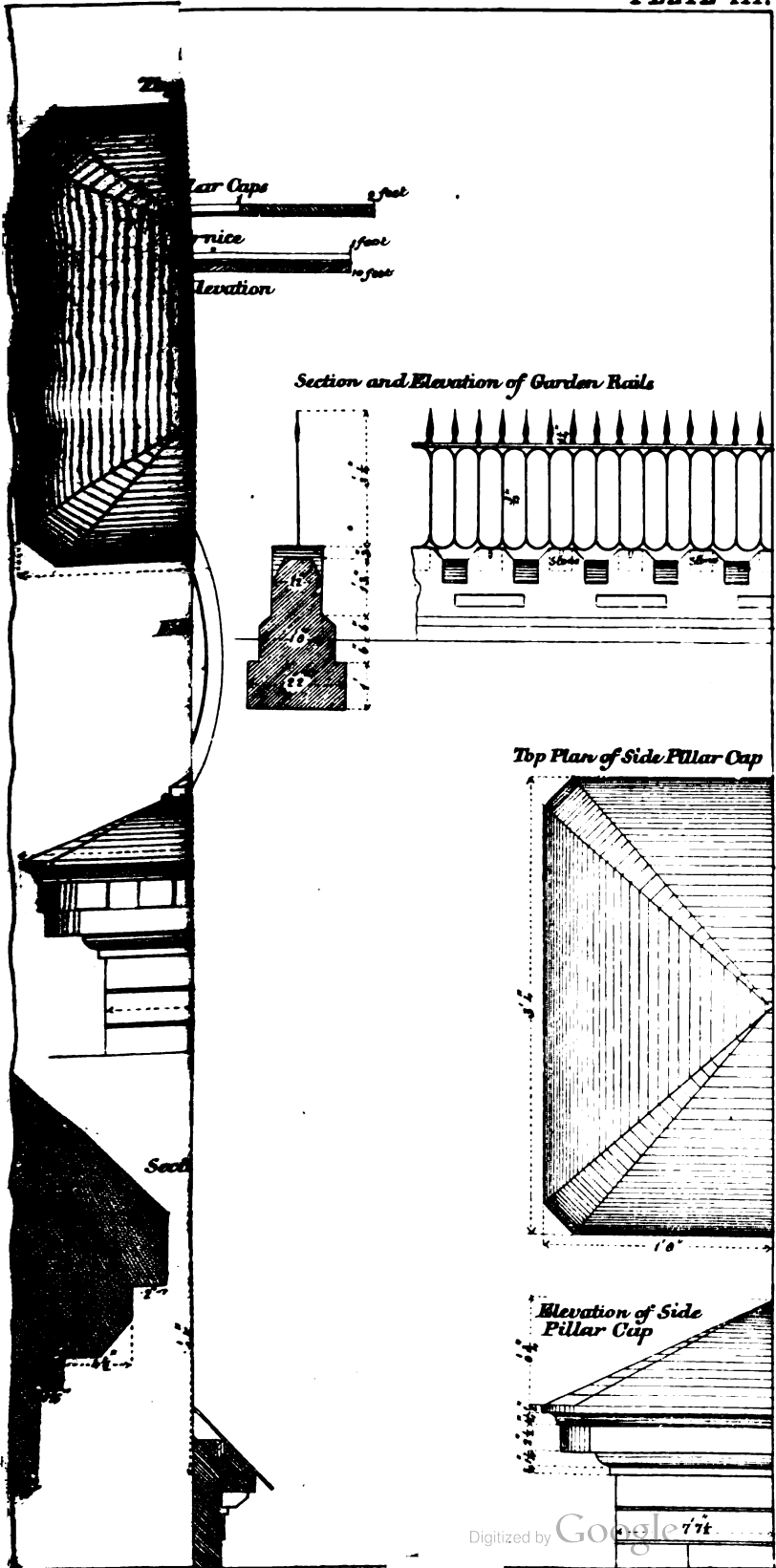
port the sheet midway without being attached to it. Corrugated iron roofs should always be of a steep pitch, (if intended to cover living rooms,) and be provided with ridge and dormer ventilation, not only for the sake of keeping the air under them cool, but also to take off the noise of falling rain. If this be done, they form of themselves with neither planking nor Leroy's composition (*at least in this climate*) a quite sufficient covering, are never too warm, and the noise of falling rain is not markedly perceptible. If the iron be laid over boarding, thick felt must be placed between the iron and the planks, or otherwise the sound of the rain is increased by the boarding alone. The Superintendent of the Gardens assures me that the roofs of these buildings constructed as they are of corrugated iron alone, fairly satisfy the above particulars. Corrugated iron roofs are suited for almost any kind of building. For churches or for dwelling-houses, they might be treated as follows :—Make the steep pitched corrugated iron with plenty of ventilation the roof covering. Let it be supported on a wrought-iron frame-work. (The whole of this roof covering might be procured ready made from England direct). Place beneath this external roof, leaving an air space between, a groined ceiling or inner wagon roof of timber. Let this be as ornamental or as plain as is desired. In this way the best external and internal effect is obtained, and the whole roof is made extremely durable.

These iron roofs can be rendered not only less ugly outside, but really picturesque by ornamental ridging and dormers, sometimes by a pierced terra cotta parapet to conceal the eaves, and by horizontal or vertical band painting in shades of the same color, the external battens forming the division of the horizontal bands. Where the iron covers the gable walls, it may be protected either by a strong barge board or by a gable coping, the latter being the most expensive. In the case of the gable coping, the iron should be let into a space under it, about 3 or 4 inches deep, and  $1\frac{1}{4}$  inches wide, and over this space on the inner side of and under the coping, a small string course should be projected, or if cope stone project well, it will suffice. The corrugated sheets should then be merely pushed rather tightly into this space, which should on no account be filled up with plaster (*see Photograph*). If the sheets be thus allowed a play, the roof will never leak there, but if the space be filled up, the plaster will crack. Apologising for the above digression, which I trust may not be altogether useless, I continue describing the designs.

The gates and rails to these lodges are of cast-iron, and have been procured from Morton and Co. of Liverpool. They will be painted with some four coats of Carson's paint. The gate pillars are of brick and mortar pointed, with the brickwork raised here and there. They are capped with cut granite, and granite is placed at the hinges, locks and bolts. The exact cost of the gates is not known—but it is something like Rs. 1,500.

The entrance to the town of Ootacamund from the Conoor side commences at a point about two miles from its centre. The high scarp road here passes under huge precipitous rocks, the forms and size of which are beautiful and imposing. At this spot a substantial toll-house and gate have just been erected. The house is built in the classic style, and consists of two rooms, each 8 by 8 feet, with a fire-place to one of them. It is of 9-inch brick and mortar strengthened by pillars, with plinth, angle quoins, cornices of building and of doors and windows, consoles, and chimney cap of plastered brickwork, painted in imitation of stone. The interior is white-washed, the exterior neatly pointed. The roof is formed of teak collar-beamed couples, with flat and pan tiles with small chunam borders at every other row of tiles, and with teak terminals over roof and dormers. The floors are of rammed earth overlaid with thick foot-square tiles. The doors are glazed, with long panes of glass to enable the toll keeper to look out at passers by. They and the windows are of teak. All the interior woodwork is coated with oil, and the exterior is painted with three coats of Carson's blue paint. This building cost Rs. 770.

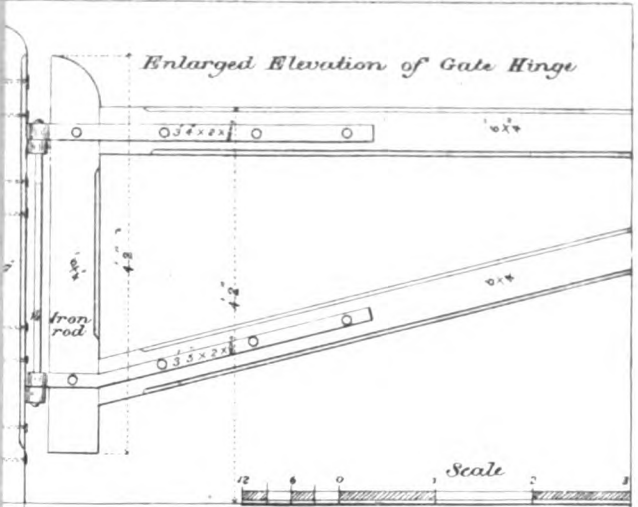
The toll-gate is of teakwood, of a simple elementary form, designed on correct principles. The gate itself consists of a head rail (6 × 4 inches), tenoned into a hanging style (6 × 4 inches). There is no bottom rail, but the top rail is kept in its place by a diagonal strut (6 × 4 inches) which is tenoned into the hanging style, and notched into the top rail. The junction of the rail and strut is further strengthened by iron plates and bolts, as shown in the drawing. The upper and lower hinges of the gate are connected by a hanging rod, 1½ inches in diameter, which runs through the eyes of both leaves of the two hinges. One leaf of each of the hinges is stoutly riveted to an iron plate, which is bolted to the hanging post by four through bolts; the other leaf of the hinges is attached in the usual way to the top rail and diagonal strut. The falling post is of the same size



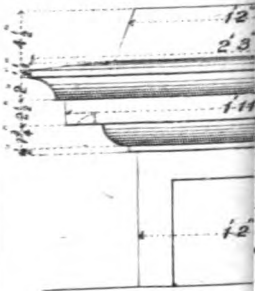




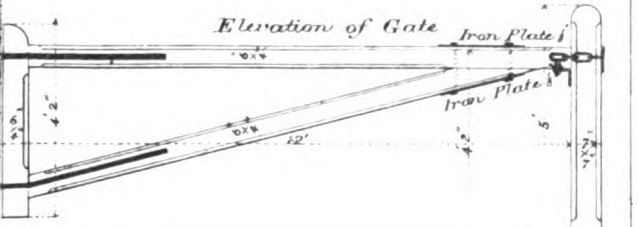
*Enlarged Elevation of Gate Hinge*



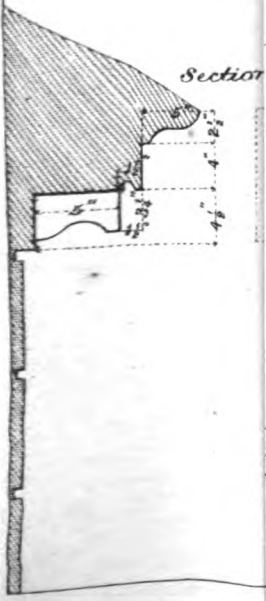
*Elevation of*



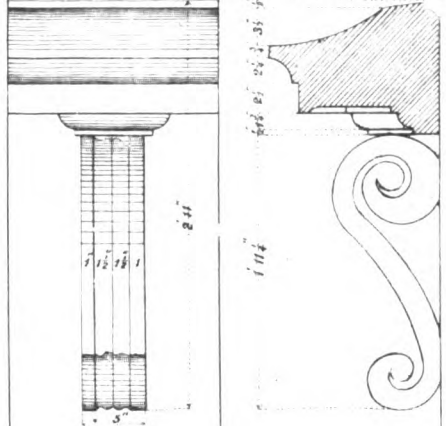
*Elevation of Gate Iron Plate*



*Section*



*Elevation and Section of Cornice & Console to Doors & Windows.*





as the hanging post, each being 7 × 7 inches. These posts project five feet above, and are sunk four feet below the ground. Their feet are morticed into two sleepers placed cross ways, and are further strengthened by angle braces. All the woodwork below ground is covered with boiling tar, and is embedded in rubble stone and mortar masonry. All woodwork above ground is coated with four coats of Carson's blue paint. This gate complete, cost Rs. 150.

A glass teakwood case mounted on a vertical bar of wood has been provided for this toll-house. Within it is posted the printed paper containing the scale of charges for passers through the toll, and other particulars; all these being thus shielded from the rain and legible in all weathers.

ESTIMATE FOR ENTRANCE LODGES.

	Contents.
Foundation to pillars, .. .. .	225 7½
„ walls of seed house and herbarium, .. .. .	240 6
„ „ office and stores, .. .. .	140 10
„ centre and end cross walls, .. .. .	180 6½
„ front walls, .. .. .	70 5
„ chimneys, .. .. .	27 0
„ steps, .. .. .	36 0
„ steps, .. .. .	32 0
Basement to pillars, .. .. .	105 5½
„ walls of seed house, &c., .. .. .	148 9
„ „ office and stores, .. .. .	86 3
„ centre and end cross walls, .. .. .	109 2
„ front walls, .. .. .	45 7½
„ chimneys,.. .. .	18 0
Pillars above, .. .. .	453 9
Walls of seed house, &c., above, .. .. .	889 0
„ office and stores above, .. .. .	511 0
Centre and end walls above, .. .. .	639 4
Front walls above, .. .. .	283 6
Chimney above 1st course, .. .. .	42 0
„ „ 2nd „ .. .. .	63 0
„ projection, .. .. .	4 4½
„ above roof, .. .. .	20 0
„ stacks, .. .. .	24 9
Gables at end walls, .. .. .	272 8½
„ centre walls,.. .. .	120 3½
	4,789 11½
Deductions, .. .. .	263 11½

Brick in mortar, .. .. .	c. ft.	4,526
Plastering with two coats chunam, .. .. .	sq. ft.	3,800
Pointing with chunam, .. .. .		1,912
Teak flooring, .. .. .		684
Granite for steps, .. .. .		60
Projected brickwork over doors and windows, .. .. .	c. ft.	50
Cornice work, .. .. .	r. ft.	162
Gable cornice, .. .. .		88
Teakwood for purlins, plates, battens, &c., .. .. .	c. ft.	35
„ trusses with iron ties, &c., .. .. .	No.	2
Sheets, corrugated iron, 6 feet, .. .. .		148
Iron bolts and nuts, large, .. .. .		52
„ „ small, .. .. .		312
Ornamental iron ridging, .. .. .	r. ft.	83
Large wrought-iron finials, .. .. .		4
Small „ „ .. .. .		12
Doors and windows, .. .. .	sq. ft.	225½
Dormer windows, .. .. .	No.	12
Painting with two coats Carson's paint, .. .. .	s. ft.	1300
Teakwood shelves, .. .. .	r. ft.	46
Excavating foundation, .. .. .	c. yds.	36

## ESTIMATE FOR TOLL-HOUSE.

	Contents.	
Foundation to pillars, .. .. .		33 4
„ doorways, &c., .. .. .		36 8
„ chimney, .. .. .		9 4½
„ walls between pillars, .. .. .		19 4½
„ „ „ .. .. .		23 9
„ „ „ .. .. .		4 10½
Basement to pillars, .. .. .		14 2½
„ doorways, .. .. .		4 6½
„ windows, .. .. .		9 0½
„ chimney, .. .. .		2 2½
„ walls between pillars, .. .. .		12 6½
„ „ „ .. .. .		14 8

	Contents.
Walls between pillars above, .. .. .	86 0
"    "    "    "    "    "    "    "    "    "	108 0
"    "    "    "    "    "    "    "    "    "	80 0
Pillars above, .. .. .	87 1½
Doorways, &c., above, .. .. .	105 0
Chimney, &c., above, .. .. .	46 11½
"    "    "    roof, .. .. .	6 1½
	<hr/>
	653 9½
Deductions, .. .. .	55 9½
	<hr/>
	c. ft.
Brick in mortar, .. .. .	598
	sq. ft.
Plastering with chunam, interior, .. .. .	870½
White-washing, interior, .. .. .	670
Pointing with chunam, .. .. .	231
Roofing with teak couples, hips, reefers, mats, tiles, &c., .. .. .	320½
Mud flooring, .. .. .	128
Doors and windows, .. .. .	40
	r. ft.
Cornice work, .. .. .	112
	No.
Dormer windows, .. .. .	2
	c. yds.
Excavating foundations, .. .. .	8
	<hr/>

ESTIMATE FOR TOLL-GATE.

	c. ft.
Brick in mortar for foundation of posts, .. .. .	64
	" " "
Posts, .. .. .	9 × 2 × 3
Longitudinal bars, .. .. .	3 " 0 " 0
Uprights, .. .. .	0 " 4 " 6
Cross ties at foot, .. .. .	6 " 8 " 0
Struts, .. .. .	2 " 8 " 0
Wastage, .. .. .	1 " 3 " 0
	<hr/>
	c. ft.
Teakwood, wrought, and put up, .. .. .	22
	lbs.
Iron for straps, bolts, and nuts, &c., .. .. .	130
	sq. ft.
Painting with two coats, Carson's paint,.. .. .	80
	<hr/>

OOTACAMUND, }  
 July 5th, 1873. }

J. L. L. M.

## No. XCIX.

## "ON THE INTEGROMETER."

*Translated by CAPTAIN ALLAN CUNNINGHAM, R.E., Honorary Fellow of King's College, London.*

[*Translator's Preface.*—The object of this translation is to introduce this new and simple instrument to English Engineers. It is a free translation of a Paper in the "Annales des Ponts et Chaussées" for March 1872, page 223, styled "Note on an instrument for finding the area, moment of inertia, and co-ordinates of the centre of gravity of a plane area," by Mr. Ed. Collignon, Civil Engineer].

The "integrometer" of Mr. Marcel Deprez, Civil Engineer, is an instrument designed to find the "area," the "co-ordinates of centre of gravity," and the "moment of inertia" of any plane figure whatever, almost without calculation. It is an extension of the instrument known as *Amsler's Planimeter*,\* now extensively used by foreign engineers.

Before describing the instrument, it will be well to recapitulate some principles of analysis.

Let EGF (*Fig. 1*) be a closed contour referred to two axes  $Ox$ ,  $Oy$  at right angles.

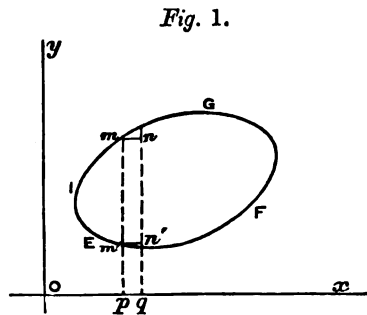
Let  $\Omega$  be the area contained within the contour.

Let  $y_1$  be the ordinate of its centre of gravity.

Let  $I$  be its moment of inertia about the axis  $Ox$ .

Let  $\rho$  be its radius of gyration about the same axis.

These several quantities are found by taking the double integrals,



\* For a very full description of this instrument, see *Professional Papers on Indian Engineering*, Second Series, No. XLII., by J. Elliott, Esq., M.A.

$$\Omega = \iint dydx$$

$$\Omega y_1 = \iint y dydx$$

$$I = \Omega \rho^3 = \iint y^2 dydx.$$

The integrations should be extended over the whole of the given area. Consider in particular the integral  $\Omega = \iint dydx$ : the first integration may be effected with respect to  $y$ ; this gives  $\Omega = \int ydx$ . In order to effect the second integration between the proper limits, conceive the operation to be governed by a moving point,—defined by the simultaneous values of  $x$  and  $y$ ,— which starting from any point I in the given contour shall return to that point I after having traced out the whole contour in the direction IGFE.

The integral  $\int ydx$  taken along the closed curve IGFEI will be equal to the area contained within that curve, for this integral is the algebraic sum of the area-elements,—positive such as  $mnqp$ , and negative such as  $m'n'qp$ —i. e., in fact the sum of the area-elements  $mn'n'm'$  which make up the area sought.

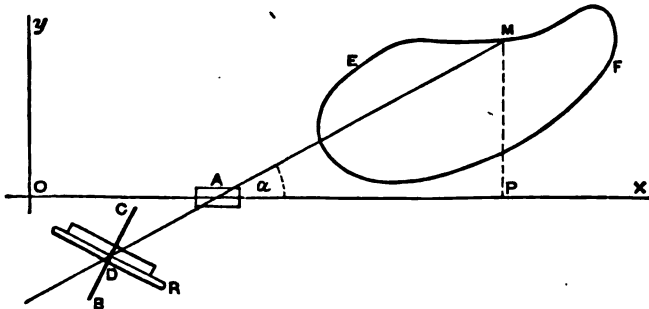
The other integrals give in like manner

$$\Omega y_1 = \frac{1}{2} \int y^2 dx$$

$$I = \Omega \rho^3 = \frac{1}{3} \int y^3 dx,$$

the integrals indicated being taken along the closed contour, in such sort

Fig. 2.



that the moving point which governs the integration shall return to its starting point.



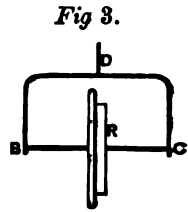
These formulæ are the basis of Mr. Deprez's method.

His instrument consists essentially (*Fig. 2*):—

1°, of a ruler OX,—which will be taken for axis of abscissæ,  $x$ ,—along which a slider A can slide freely;

2°, of a straight rod MAD which is freely pivoted on the slider A, and carries at one end M a pointer with which the contour of the given figure EF is to be traced (*Fig. 2*); at the other end it carries a stirrup of which (*Fig. 3*) is an elevation.

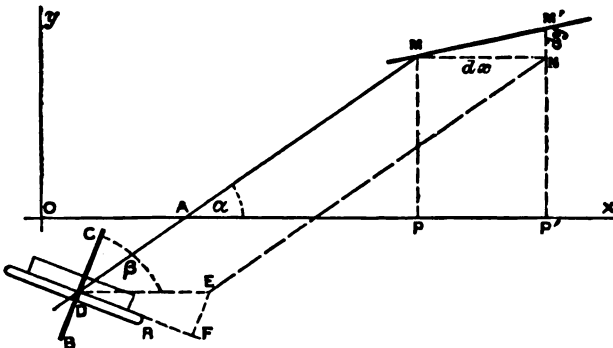
The branches of the stirrup are traversed by the horizontal axis BC of a wheel R which rolls on the plane of the figure. An arrangement which will be described further on sets the axis BC continually in a direction making with the ruler OX an angle  $\beta$ , which depends—according to a certain law—on the inclination MAX =  $\alpha$  assumed by the rod MAD.



On the circumference of the wheel is a tire (or edge) on which it rolls, and to one side is a drum of somewhat less diameter, divided into 100 equal parts. A vernier and a reading disc fixed on the stirrup enable one to estimate tenths of divisions, and to read the number of turns of the wheel. These accessories are not shown in *Figs. 2* and *3*.

*Theory of the instrument.*—Take the line OX as axis of abscissæ,  $x$ ; and a perpendicular to it Oy as axis of ordinates,  $y$ .

*Fig. 4.*



It is proposed to find the length of the arc which the wheel describes

on the paper, when the pointer traces out an infinitesimal arc  $MM'$  of the given contour (*Fig. 4*).

This arc-element  $MM'$  may be replaced by its projections  $MN$ ,  $NM'$  parallel to the axes, and instead of the displacement  $MM'$  which the pointer really undergoes, the components ( $MN = dx$ ,  $NM' = dy$ ) of this displacement may be considered. In consequence of the displacement  $dx$ , the rod  $DAM$  is moved parallel to the axis  $OX$ , and the wheel  $R$  undergoes therefore a translation  $DE$  equal and parallel to  $dx$ ; to find the rotation which thence results about its axis  $CB$ , resolve this translation  $DE$  into two components, viz.:  $DF$  perpendicular to, and  $FE$  parallel to, that axis. Call  $\beta$  the angle which  $CB$  makes with  $OX$ ; then

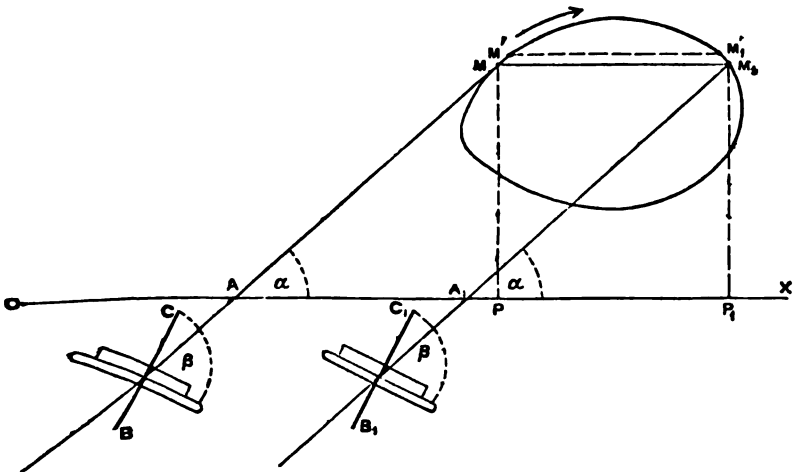
$$DF = DE \sin \beta = dx \sin \beta$$

$$FE = dx \cos \beta.$$

This latter displacement  $FE$  is parallel to the axis of rotation of the wheel, and therefore does not cause any rotation. The former displacement  $DF$  causes a rolling of the edge of the wheel over the plane of the figure, so that the horizontal displacement  $dx$  of the pointer  $M$  impresses on the wheel a rotation  $da = dx \sin \beta$ , this rotation being measured by the length of the arc which it describes in the plane of the paper.

During the displacement  $dy$ , the point of contact of the wheel describes

*Fig. 5.*



a certain arc-element, and the wheel traces on the paper an arc-element,

which need not be calculated. For, consider the points  $M_1, M_1'$  on the closed contour (*Fig. 5*) which have the same ordinates  $y$ , and  $y + dy$  as the points  $M, M'$ . When the pointer during its motion passes from the point  $M_1'$  to the point  $M_1$ , the arc-element described by the wheel, in consequence of the vertical displacement  $-dy$ , will have a value equal but opposite in sign to that which it had during the passage from the point  $M$  to the point  $M'$  in consequence of the displacement  $+dy$ . For in the two positions corresponding to the points  $M$  and  $M_1$ , the pointer-carrying rod is in positions perfectly similar with respect to the axis  $OX$ . It makes with that axis the same angle  $\alpha$ , and this insures the same direction to the axis of the wheel.

It follows that the algebraic sum of the arc-elements described by the wheel—in consequence of the displacements of the pointer parallel to the axis of  $y$ —vanishes when taken between two points  $M$  and  $M_1$  which have equal ordinates; the same thing takes place when the pointer after tracing out the closed contour  $EF$  returns to its starting point. The whole arc described by the wheel under these circumstances is, therefore, the definite integral of the expression.

$$d\alpha = dx \sin \beta, \dots \dots \dots (1).$$

Also  $y$  being the distance  $MP$  of the point  $M$  from the axis  $OX$ ,  $\alpha$  the angle  $MAX$ , and  $l$  the constant length  $AM$ , then

$$\sin \alpha = \frac{y}{l} \dots \dots \dots (2).$$

Suppose now that a certain relation has been established between the angles  $\alpha, \beta$ , and consider in particular the three following cases:—

$$\beta = \alpha; \quad \beta = (2\alpha + \frac{\pi}{2}); \quad \beta = 3\alpha.$$

These will lead to the determination of areas, centres of gravity, and moments of inertia.

*1st Case.*— $\beta = \alpha$ . *Calculation of areas.*—In this case,

$$\sin \beta = \sin \alpha = \frac{y}{l}$$

hence by (1),  $d\alpha = \frac{y}{l} dx$ .

Let  $a_1$  be the integral of  $d\alpha$  extended over the whole contour, and furnished by the reading of the whole arc rolled in the motion of the wheel; then  $a_1 = \int y dx \div l$ , the integral being taken over the entire length of the given contour. Hence

$$\int y dx = la_1.$$

But it has been seen that this integral  $\int y dx$  is actually equal to the area, of the figure.

2nd Case.— $\beta = (2\alpha + \frac{\pi}{2})$ . To find the centre of gravity.—In this case,

$$\sin \beta = \sin \left( 2\alpha + \frac{\pi}{2} \right) = \cos 2\alpha = 1 - 2 \sin^2 \alpha,$$

therefore by (2),  $\sin \beta = 1 - \frac{2y^2}{r^2}$

$$da = \left( 1 - \frac{2y^2}{r^2} \right) \cdot dx.$$

Hence denoting by  $a_2$  the integral extended over the whole contour and read on the wheel :

$$a_2 = - 2 \int y^2 dx \div r^2$$

for the term involving  $x$  vanishes between the limits, thus

$$\int y^2 dx = - \frac{1}{2} r^2 a_2 \dots \dots \dots (4).$$

Half this integral divided by the area of the figure gives the ordinate  $y_1$  of the centre of gravity, thus,

$$y_1 = \frac{\frac{1}{2} \int y^2 dx}{\int y dx} = - \frac{\frac{1}{2} r^2 a_2}{la_1} = - \frac{1}{4} \cdot \frac{a_2}{a_1}.$$

3rd Case.— $\beta = 3\alpha$ . To find the moment of inertia.—In this case,

$$\sin \beta = \sin 3\alpha = 3 \sin \alpha - 4 \sin^3 \alpha = 3 \frac{y}{r} - 4 \frac{y^3}{r^3},$$

$$da = \left( 3 \frac{y}{r} - 4 \frac{y^3}{r^3} \right) dx.$$

Let  $a_3$  be the integral of  $da$  extended over the whole contour, then

$$a_3 = 3 \frac{\int y dx}{r} - 4 \frac{\int y^3 dx}{r^3}$$

the integrals being extended over the same contour. Hence

$$\int y^3 dx = \frac{r^3}{4} \left( 3 \frac{\int y dx}{r} - a_3 \right)$$

But as  $\int y dx = la_1$ , it follows that

$$\int y^3 dx = \frac{r^3}{4} (3a_1 - a_3) \dots \dots \dots (5).$$

The third of this integral is the moment of inertia of the figure about OX, and the square of the radius of gyration will be obtained by dividing this by the area ; this gives

$$\rho^2 = \frac{\frac{1}{4} \int y^3 dx}{\int y dx} = \frac{r^2}{12} \cdot \frac{3a_1 - a_3}{a_1}.$$

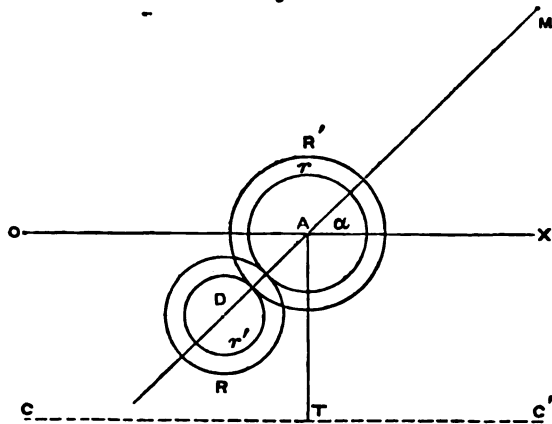
*Method adopted to secure at will the relations*

$$\beta = \alpha; \quad \beta = \left(2\alpha + \frac{\pi}{2}\right); \quad \beta = 3\alpha.$$

The relation  $\beta = \alpha$  is obtained by fixing the stirrup in the prolongation of the rod AM. Instead of making the axis A traverse a material ruler OX, it is guided along that line by means of a rod AT, of which the end T, shaped like a double square, slides in a groove in a fixed ruler CC', which keeps it always perpendicular to its own direction.

The straight rod DAM (*Fig. 6*) moveable on the axis A, carries at M the pointer, with which the given contour is to be traced, and at D the vertical axis of the stirrup, between the branches of which the wheel turns.

*Fig. 6.*



On this axis D are fixed two toothed wheels R,  $r'$  of unequal diameter, which continually engage two other wheels  $r$  and  $R'$  centred on the axis A.

Each of the wheels  $R'$ ,  $r$  has on its circumference a hole into which can

be inserted a small screw fixed to the rod AT; this enables either of the wheels to be fixed and prevented from turning. Its whole motion is then reduced to a translation along CC'.

That one of the toothed wheels whose centre is at D, for instance the wheel  $r'$ , which works into the wheel  $R'$  so fixed then moves *like a planet* round A. Denote by  $\alpha$  the angle MAX, and by  $\beta$  the angle which a line fixed on  $r'$ , and so taken that  $\beta = 0$ , when  $\alpha = 0$ , makes with OX, then by the known properties of "planet-wheel movements,"

$$\beta = \alpha \left( \frac{R'}{r'} + 1 \right)$$

Making in succession  $R' = r'$ , and  $R' = 2r'$ , there result  $\beta = 2\alpha$ , and  $\beta = 3\alpha$ . Now these are precisely the two cases met in the instru-

ment in which  $\frac{R'}{r} = 2$ , and  $\frac{r}{R} = 1$ . It follows that according as the wheel  $R'$  or the wheel  $r$  is fixed, the angle  $\beta$  will be equal to  $3\alpha$  or to  $2\alpha$ .

To make  $\beta$  equal to  $(2\alpha + \frac{\pi}{2})$ , it will be sufficient to place the axis of the wheel at right angles to  $OX$  at the beginning of the operation whilst  $AM$  is applied along that line. This is fulfilled by using one of the screws and the corresponding hole made in the wheel  $r$ .

*Trial and Use of the instrument.*—To ascertain that the "integrometer" is in good order, and will give exact results, it is necessary to see that it fulfils the following conditions.

1°. The instrument being set up, bring the pointer on the line  $OX$ , and direct the stirrup, or—which amounts to the same—the horizontal axis of the wheel along that same line. This is easily done by bringing a hole made in the wheel  $r$  opposite the screw fixed in the rod  $AT$ . Then tighten a screw (not shown in the figure) intended to fix the vertical axis of the stirrup on the rod  $DM$ . This done, set free the two wheels  $r$  and  $R'$ , after having set the zero of the wheel opposite the zero of the vernier, and trace out the line  $OX$  with the pointer. Under these circumstances there should be no motion of the wheel which should remain at the zero of its graduation.

2°. Loosen the screw by which the stirrup's vertical axis was set fast on the rod  $DM$ , and set the horizontal axis of the wheel at right angles to the line  $OX$ : the second hole made in the wheel  $r'$  will then be opposite to the screw corresponding to this wheel; tighten this screw so as to set the wheel  $r$  fast on the rod  $AT$ , and set the pointer  $M$  on a straight line parallel to  $OX$ , and at a distance from it equal to  $AM \times \frac{1}{\sqrt{2}} = \cdot 7071$   $AM$ . In this position the line  $AM$  makes with  $OX$  an angle of 45 degrees; if the wheel-work is well made, the vertical axis of the stirrup will have turned through twice the angle, *i. e.*, through 90 degrees, and the horizontal axis of the wheel will be parallel to  $OX$ . If then, in this position, the zero of the wheel be brought opposite the zero of the vernier, it should remain steady whilst the pointer traces out a parallel to  $OX$ .

3°. To try the wheel-work  $R'$  and  $r'$ , loosen the screw corresponding to  $r'$ , and screw up that corresponding to  $R'$ , then trace out with the pointer another parallel to  $OX$  at a distance from it equal to  $AM \times \frac{\sqrt{3}}{2} = AM \times \cdot 866$ ; the rod  $AM$  will then make with  $OX$  an angle of 60 degrees,

and the horizontal axis of the wheel should have turned in consequence through thrice the angle, *i. e.*, through 180 degrees in the horizontal plane; when the pointer is made to trace out the new parallel to OX, the wheel should, as in the preceding cases, remain at the zero of its graduation.

*To find the area of a figure.*—Arrange the instrument as directed in the first trial, then trace out the contour of the figure, always in the direction of the hands of a watch, ending at the starting point. The formula for the area of the figure is  $\int y dx = a_1 l$ ,  $a_1$  being the length of the arc through which the wheel has turned round its horizontal axis, and  $l$  the length AM. To find  $a_1$  it is not sufficient to read the number of divisions which measure the whole rotation of the wheel; it is further necessary to find the value  $\lambda$  of the length of the arc corresponding to one division. The value of  $\lambda$  can be found in two ways:—

1°. By tracing with the pointer a geometrical figure of known area: let A be the area of this figure,  $n_1'$  the number of divisions read on the wheel after the operation, then

$$A = la_1 = ln_1' \lambda, \text{ whence } \lambda = A \div ln_1'.$$

This constant once found, the value of the area of any figure whatever, for which the wheel has turned through  $n_1$  divisions, can be found from the formula,

$$\text{Area} = n_1 \lambda l.$$

The constants  $l$  and  $\lambda$  are the *parameters* peculiar to the particular instrument used.

2°. The value of  $\lambda$  can also be found by setting the horizontal axis of the wheel at right angles to OX, and tracing this line with the pointer, till the wheel has turned through 100 divisions, or through one complete revolution. Then measure the path traced by the pointer; the value of  $\lambda$  is equal to the length of this path divided by 100.

*To find the centre of gravity.*—Arrange the instrument as in the second trial, set the wheel to zero, and then trace the figure with the pointer in the same direction as before. The distance  $y_1$  of the centre of gravity from OX is

$$y_1 = -\frac{l}{4} \cdot \frac{n_2}{n_1},$$

$n_1$ ,  $n_2$  being the number of divisions read in the process of finding the area, and in the present operation respectively. To avoid the confusion which might follow from  $y_1$  being affected with the negative sign, it is convenient to set up the instrument so that the centre of gravity may

fall beyond the line OX with respect to the fixed ruler CD, a condition easy to fulfil *à priori*. The finding the actual position of the centre of gravity requires of course, whenever the given figure is unsymmetrical, a repetition of the operation about an axis not parallel to OX. -

To find the moment of inertia.—Arrange the instrument as in the third trial; trace the contour always in the direction of the hands of a watch, and note the third reading, say  $n_3$ . The value of the moment of inertia is

$$I = \frac{r^2}{12} \cdot \lambda (3 n_1 - n_3),$$

and that of the square of the radius of gyration is

$$\rho^2 = \frac{r^2}{12} \cdot \frac{3n_1 - n_3}{n_1}.$$

Such is the description of Mr. Deprez's new instrument. Its use is simple and easy. The instrument enables the rapid and correct performance of operations hitherto considered very laborious, especially when dealing with tortuous contours, which are with difficulty reducible to simple geometrical figures.

The principle of the apparatus is one of great fertility, for the planetary wheel-work by which the ratio  $\beta : a$  is made equal to 2 or to 3 might easily be replaced by a train of wheels yielding any ratio whatever. If the inquiry be confined to the consideration of integer values  $p$  of this ratio,  $\sin pa$  if  $p$  is odd, and  $\sin \left( pa + \frac{\pi}{2} \right)$  or  $\cos pa$  if  $p$  is even, are expressible in finite polynomials of the degree  $p$  in  $\sin a$ . Now  $\sin pa$  introduces into the investigation the  $p^{\text{th}}$  power of the ordinate  $y$ ; a similar instrument, somewhat differently mounted, would thus furnish the value of the integral  $\int y^p dx$  taken throughout the length of a closed contour; this integral would be expressed in terms of the integrals  $\int y^{p-1} dx$ ,  $\int y^{p-2} dx$  ..... which would have to be taken throughout the length of the same contour, and which would moreover be found by using the same instrument after having changed its mounting.

Mr. Deprez has considered the method which can be drawn from these remarks of graphically solving algebraic equations of any degree whatever, and by an ingenious modification of his instrument, has succeeded in



freeing the process from the necessity of completing the entire round of the figure, and returning to the starting point in the successive trials.

In fine—to return to the particular instrument which has been described—the “integrometer” is an instrument simple, inexpensive, easy to handle, and one which seems likely to be of the greatest use, for there are few inquiries in which it is not required to find areas, centres of gravity, or moments of inertia of various plane figures, (*e. g.*, in finding the centre of pressure of plane surfaces immersed in a heavy liquid, in questions of strength of materials, of stability of floating bodies, &c., &c.) and it is to be hoped that this instrument will come into common use among engineers, as it will serve to economize time and labor.

A. C.

---

No. C.

---

NAYLOR'S CLAY-SCOOP AND SUB-AQUEOUS  
EXCAVATOR.

[*Vide* Plate V.]

---

BY ROBERT DE G. NAYLOR, *1st Assistant Supdt. of Telegraphs.*

---

*Description of a new method of sinking Wells and facilitating the sinking of cylindrical foundations of Bridge Piers, &c.*

THIS method is the result of several experiments made partly at my own expense, and partly at that of some friends, who very kindly allowed me to experiment on their wells, to give me different opportunities of trying my method of well-sinking, which I put in practice whenever I had time, with no other object than the discovery of some means of facilitating the completion and reducing the heavy cost of works of the kind.

I consider the idea entirely my own, as I have never seen it tried on any of the numerous works I have inspected, nor have I ever heard it mentioned by any Engineers, or seen it in any books on Engineering subjects. Indeed I have observed in all parts of the country, that the very contrary to my method has invariably been adopted; when any water has been taken out of a well in course of sinking, that it has been led as far as possible away from the well, instead of being utilised on it in any way.

My method is to make the water assist the process of sinking the well; I therefore draw it up from inside as fast as possible, (by pumping or otherwise, according to the supply of water, and the importance of the work,) as regularly as the earth which is being raised from the bot-

tom, and pour it over the outer sides of the well, equally all round, thus causing it to run down the outside of the masonry, and cut and loosen the earth round it as far as it possibly can, and then to percolate through the disturbed earth round the well into it again from the bottom.

This will be found very considerably to reduce what may be called the lateral pressure and friction, and to most materially aid the operation of sinking. It has a most surprising effect in some soils, especially where the water is a great depth below the surface—and I believe it will be equally efficacious where the water is close, if properly managed.

The principle is, that water will find its own level; and when it is drawn up from inside a well, and poured all over the outside evenly, regularly, and with rapidity for any length of time, it will naturally cut and loosen the disturbed earth round the well for a considerable depth, and find its way into it again from the bottom. The action of the water percolating through the earth round the well,—even if ever so slow,—will be a great help to the sinking of the well; and it may be accelerated by keeping the level of the water inside very much below that of the outside.

I first tried my method as an experiment on a well I was sinking for myself at Meerut in 1868: and at the time I had a gang of skilled workmen, who had been employed on the sinking of the East Indian Railway Bridge Piers in the Jumna river at Delhi, and other similar works. They besought me not to do it, and said it had never been done on any works of the kind in the country. But when I insisted, and continued my experiment for some time, and they saw the result, they were astonished at it, and said, that they “thought they had seen all the Engineering knowledge of the English on the Railway, but there was more to be seen yet.”

On large and important works I would recommend, as soon as the earth and water can be simultaneously raised, that it be done without any cessation, and with all practicable rapidity: the water being evenly poured down the masonry all round, and the earth used to form a dam round it in order to raise the level of the water outside, as much above that of the inside as possible. This will facilitate the action of percolation, and help to keep it up in the event of any stoppage of the work. Once the action commences, there is not much difficulty in keeping it up; in fact the work has only to go on, as long as the earth and water are regularly raised, it will continue. But if it is checked through any delay or stoppage of the work, it is difficult to start it again at times as

the earth settles, and the water will not sink through it till the well moves, which there is always some trouble about, as it is held tight by the lateral pressure of the earth, increased by the settling of the disturbed soil which has taken place by stoppage of work. This necessitates in India the use of an instrument for Sub-aqueous excavations which can be worked in any substance short of stone or rock, with ordinary native labor, night and day without intermission, so that there may be no check to the progress of the work, and this instrument I have endeavoured to supply by my Clay-Scoop or Sub-aqueous Excavator;—with what success, the future will decide.

It may be urged that my method would be of no assistance or very little, in some soils. I beg to differ on this point. In all the experiments I have tried, I have found it of the greatest use. I will not answer for it in other countries, as my experience of such works is entirely Indian; but in India where the sub-soil is generally sand, I consider it very valuable. I can believe in compact close soils it would afford little assistance; but it should not be forgotten that the slightest assistance is of importance on works of the kind.

The saving of *time* effected by the rapidity with which a well can be sunk by my method, will fully make up for any extra expense incurred in raising the water; even if it will not effect a large saving of *expenditure*, which has always been the case on all the experiments I have tried.

As before stated, I have tried several different and expensive experiments with numerous wells in my endeavours to find a practicable method of facilitating the completion, and reducing the cost of well-sinking. As the level of the water inside a well can be much more easily raised than that outside, I have not failed to try it; but I regret to say it had no visible effect, though the level of the water inside was kept very much above that of the outside for a considerable time, a large excavation having been made round the well as deep as possible, and the water pumped up from it into the well.

There is no doubt that in drawing the water from inside a well, a large quantity of the sand, under and round it, is drawn in also by the action of the water; but this helps the sinking of the well, though it actually increases the quantity of earth to be got out; and I consider this the proof of my theory, that the percolation of the water does take place and assists the work. I have known instances in which the surface soil

has been taken out of some wells after they had been sunk to a depth of forty feet.

It must not be supposed that it is unnecessary to weight a well when sinking by my method: on the contrary, nothing should be neglected that will help the work; though more sinking can be done without weight by my method than by any other: and when weights are used, they should be so arranged, as to allow of the water running down the outside of the masonry freely. However, I consider it very necessary that every precaution should be taken to prevent bricks, timber, &c., falling into the excavation round the outside of a well while it is in course of sinking, as they are carried down by the action of the water and of the well, and when any quantity gets down on one side, it checks the even or perpendicular sinking of the same, and causes it to lean over to one side.

I do not consider the shape of the wells for Bridge Piers should of necessity be perfectly cylindrical; the substance they have to be sunk through in most parts of this country is sand, with very thin layers of set silt or kunkur,—which offer no very great obstacle to overcome, in sinking the foundations;—and therefore it would be advantageous to shape the Piers, so as to better resist the scour and force of sudden floods. That single cylinders of small diameter have proved a mistake, is illustrated by the failure of most important Bridges on some of the Indian Railways. Some years ago I superintended the sinking in a river of some Piers, which consisted of double wells in one mass of masonry. To the best of my recollection, the measurements were 5 feet internal diameter of wells, and 19 feet by 11 of the total mass of masonry, including both wells, and no difficulty was experienced in sinking them on account of the shape.

A suggestion was made not long ago of conical-shaped Piers for the bridges of large rivers. I am not aware who was its author, but I consider the suggestion an excellent one. As far my experience goes, there will be no difficulty in sinking them. Small test wells could be sunk to ascertain the nature of the river bed where conical Piers are to be used. Doubtless it will cost more to sink a pier 24 feet diameter at the base and 12 feet at the top, than it would to sink a 12 feet cylinder; but I think with conical Piers there will be no occasion for making the bridge twice over, and spending fabulous amounts on temporary bridges, and maintenance and supervision of the same. The shape of the conical Pier

will, I am of opinion, help it in sinking, and will divert the scour of the water from its base, which is a great advantage: and I believe Engineers of Indian experience will agree with me in pronouncing the conical form of Pier superior even to the cluster of cylinders, which has proved so successful on the East Indian Railway.

In writing the above, I only desire to respectfully lay before the Government of India my experience of well-sinking, and nothing is further from my intentions than to criticise any Engineering works in any part of the country, though I have seen most of the important ones in every stage of progress, and after completion.

---

*Description of a new Clay-Scoop and Sub-aqueous Excavator, for sinking Wells, cylindrical foundations of Bridge Piers, and sub-aqueous excavations of all kinds, in clay, rubble, set silt, gravel, shingle, kunkur, or sand.*

---

I think it necessary to say that the idea of this Instrument was suggested to me by the common native scoop, called "Jham," and (as it will be observed) my instrument is nothing but two "Jhams" modified, and hinged together, with two handles or arms to each blade, attached to the sides, instead of one in the middle. This being necessary in order to allow of the use of the hammers when they are required.

The hammers are the common monkey-hammers adapted for this instrument when working in hard substances, and so attached, as to be lowered and raised with it, or raised separately, without interfering with its action.

The instrument acts on the principle of the common pick and hoe. The two blades face each other, and have arms at right angles, so that when the blades are driven into the earth, and the arms pulled up, the blades come together, turning up whatever is between them, and enclose it—and the spoil can be raised without loss through any depth of water.

After having in the course of several years personally inspected the sinking of the foundations of the greater number of the largest and most important bridges in India, and seen all the different descriptions of apparatus ever used in this country, and carefully made observations of their comparative performance, I am of opinion that my scoop is the only instrument yet invented, that answers all purposes of sub-aqueous excavations, in anything short of stone or rock.

I am of opinion that the loss of many important and most expensive Bridges in India has been caused by the want of some instrument of the kind, that could satisfactorily ascertain the nature and depth of the substance they rested on.

I have often observed a layer, or stratum of clay, shingle, or set silt, only a few inches in thickness, and of little more than ordinary hardness, check most of the instruments at present used for sub-aqueous excavations; and I believe it is thus that experienced Engineers have been led to believe that they had got good foundations, when they were unable to excavate further, whereas it was only the imperfect instruments used, that were unable to work in any hard substance.

In working in hard substances, especially clay, and those with a clayey admixture and tenacity, it is necessary to fairly break and turn them up before they can be raised.

The old native scoop "Jham" is capable of fairly breaking and turning up these substances, when properly made, and properly used; but it is not able to bring up any quantity of the spoil, in any depth of water: and owing to its clumsy construction, and the rude methods of working it, its use has not been found very satisfactory.

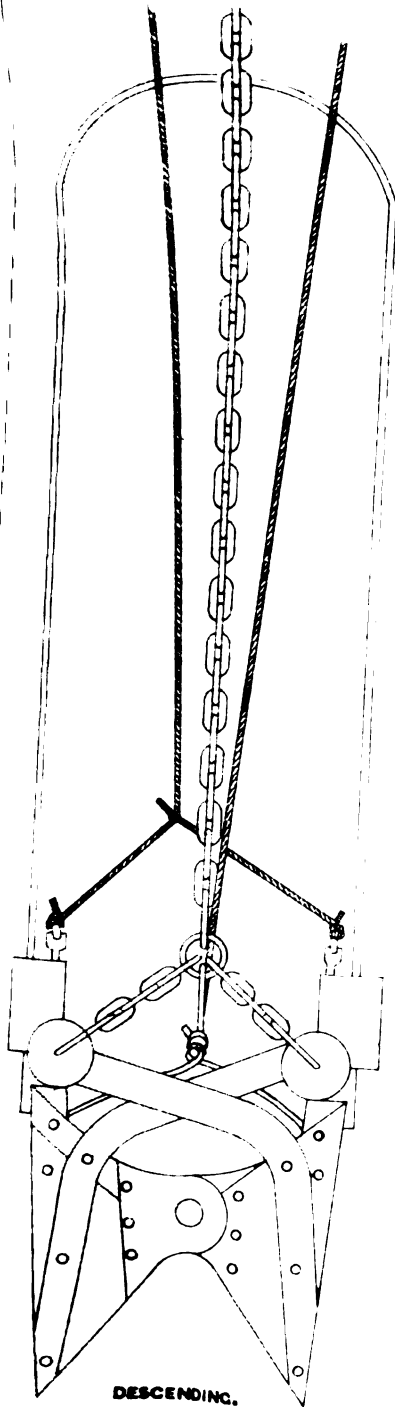
In many parts of the country, the Jham is used entirely by means of divers, who go down with it, and put it in a position to grip or act: these divers are frequently drowned by getting entangled in the ropes or chains, or from being stunned by knocking their heads against the chains; or sides of the wells: and the employment of divers is always expensive, and troublesome.

I have labored to produce an instrument that will alone answer all purposes of sub-aqueous excavation, an instrument that can be worked economically and effectually, night and day, without intermission, by hand or machinery, equally well either in hard or soft substances without the aid of divers, or other troublesome and expensive means. And I now beg to offer it for trial and competition with any of the apparatus now used for purposes of Well and foundation sinking of all kinds, in deep or shallow water.

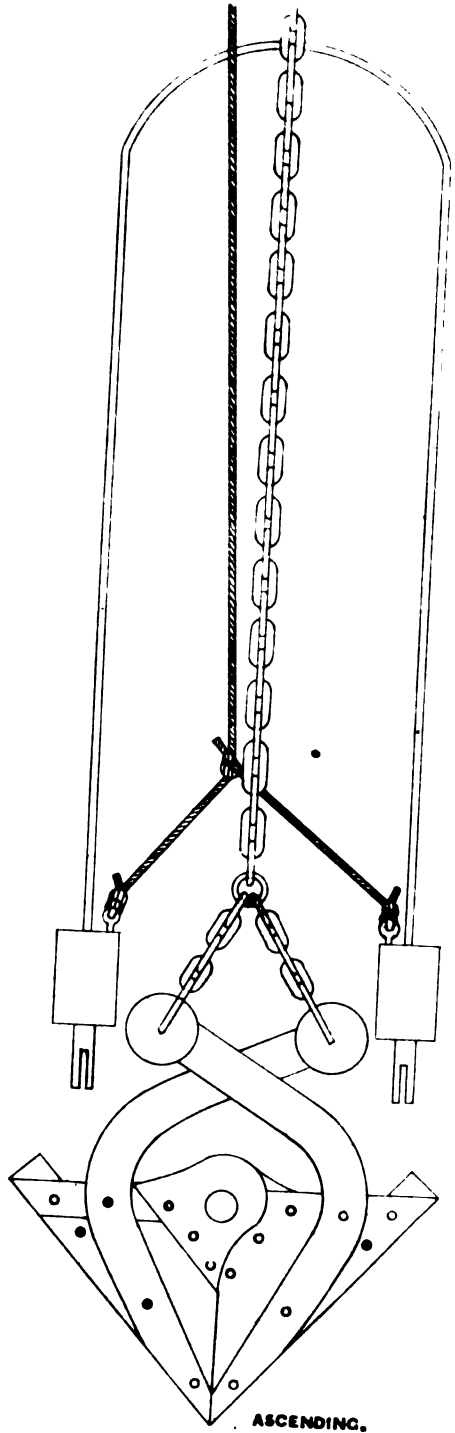
The scoop is worked by lowering it open. It is kept open by means of a link or key which must be removed before it is raised, to allow the cutting blades to turn up the spoil and close.

In hard substances, such as clay, rubble, set silt, gravel, shingle, or

**MAYLOR'S PATENT CLAY SCOOP, OR SUB-AQUOUS EXCAVATOR.**



**DESCENDING.**



**ASCENDING.**







kunkur, it is necessary to drive the blades in with the hammers,—single, double or quadruple,—according to the hardness of the substance worked in. After a little practice the workpeople will know exactly how many strokes of the hammer are required to drive it in sufficiently; and the scoop should not be driven in too deep. The hinge should always be an inch or so clear of, or above the earth, to prevent its being strained and to admit of the instrument being worked fast.

When the blades are driven in, and the opening link removed, the instrument has only to be raised, when the blades will break and turn up the earth, uniting in a right-angle triangle resembling a square box, cut across diagonally, and thus enclose and bring it to the surface.

For working in soft substances, such as sand, puddly clay, soft silt, &c., the hammers need not be used, (they are so contrived as to be detached at will,) as it is only necessary to keep the scoop open and\* shake the chain a little, when it will sink itself a sufficient depth to bring up a full load: or it may be let down with a little run, and it will bury itself.

In soft substances this instrument may be worked with great rapidity—and in hard ones it is not slow.

The scoop can be made of any size, and for working with any power, but up to a calibre of two cubic feet contents, it can also be worked equally as well by the hand: which is perhaps its greatest advantage.

A scoop of one cubic foot content can be worked all day by four coolies and a pair of bullocks,—I prefer working with this size, as there is no delay and loss of time from breaking of chains, and fishing for the scoop,—and it can be kept constantly and regularly at work at a small cost.

I take no credit for the invention of the hammers, as they are the common monkey hammers, which I have only adapted to my instrument:—and I think it necessary here to add that the only hammer I have ever used is the pole, with which I have broken through layers of clay and kunkur, and also several layers of sandstone from 1 to 2 inches thick: but as the use of the pole-hammer requires practice and skill, the monkey hammers are obviously better.

R. DE G. N.

\* If used in this manner, and without the hammers, the arrangement is very similar to *Bull's Hand-Dredger*, vide *Professional Papers*, [2nd Series,] Vol. I., page 279.—(ED).

## No. CI.

## MYSORE LIMESTONES.

BY LIEUT.-COL. R. H. SANKEY, R.E., *Chief Engineer, Mysore.*

*From—G. NORTON, Esq. To—Chief Engineer, Mysore.*

*Dated January, 1867.*

I beg to forward the result of my analysis of the several samples of limes received with your letter of the 5th December last.

A brief statement of the processes pursued in the analysis is annexed, and the results obtained from the several samples tabulated.

The analysis was conducted with the view of determining the qualities of the limes and their fitness for the preparation of mortar for building purposes.

With this object in view the quantity of pure carbonate of lime in each sample was ascertained. In this respect the samples vary considerably, ranging from 52 per cent. in No. 13 to 97 per cent. in No. 2. No. 17 contains only 39 per cent. of carbonate of lime; this is not a true lime, but is a magnesian limestone; the quantity of carbonate of magnesia contained in it is 11·823 per cent.

The sand and clay, and silica, and iron and alumina, which are evidently derived from the soil in the localities in which the limes are found, also vary considerably.

No.	13	contains	44·3	per cent.	of these	impurities.
"	19	"	42·8	"	"	"
"	16	"	42·6	"	"	"
"	6	"	31·4	"	"	"
"	3	"	28·8	"	"	"
"	9	"	27·7	"	"	"
"	5	"	26·3	"	"	"
"	7	"	25·7	"	"	"
"	8	"	19·8	"	"	"
"	11	"	19·1	"	"	"

These foreign matters are in the proportion of  $\frac{1}{8}$ th to nearly the quantity of carbonate of lime contained in the above-mentioned samples. They must in consequence be set down as limes of inferior quality, and their use in the preparation of mortar must be regulated by the quantity of sand to be added to them, which of necessity must be much less than that used with rich and fat limes. These latter contain generally less than 6 per cent. of impurities, and after calcination, increase remarkably in volume when water is added to them, the increase being as much as from 3 to 4 parts of their original volume when measured, and they absorb about  $1\frac{1}{2}$  times their bulk of water during expansion. The quantity of sand to be mixed with lime for the purpose of making mortar should be regulated by the rate of expansion of the lime during its absorption of water in the process of slaking. A lime that expands three times its volume will take three times the quantity of sand.

All the samples contain oxide of iron. The presence of this substance imparts color to the limes when they are heated; the color varies in degree in proportion to the quantity of iron present in the sample. The color noted in the table will no doubt be greatly heightened when the limes are in a mass or quantity, owing to the prolonged heat they will undergo during their calcination. Nos. 1, 2 and 20 were least affected as regards color when heated, and as they contain, respectively, 91, 97 and 93 per cent. of pure carbonate of lime, are better fitted than the other samples for smooth plastering the interior of buildings.

The sand and clay, and silica, and iron and alumina, were determined in groups; it was not considered necessary to separate each singly; their separation would give no additional information in regard to the true quality of the limes and their fitness for the preparation of mortar, while the processes involved in the analysis for their separation would add very considerably to the labor.

The quantity of impurities in each sample vary, but the carbonate of lime seems to be pretty constant, as will be seen by the results obtained in the following samples, which were analysed twice to correct some discrepancies in the first results:—

Sample No.	7,	Carbonate of limes	1st trial.	2nd trial.
"	9,	"	71.0	69.0
"	11,	"	68.4	68.0
"	16,	"	73.6	73.6
"	17,	"	53.0	53.4
"	17,	"	39.0	38.0

In No. 21 "Specimens of lime procurable at Chittledroog" there were three separate packets, marked—

Chunam-powder.

Burnt lime.

Limestone.

The limestone alone was analysed. If the chunam-powder and burnt lime are from the same source, or from the same sample of lime, it would be needless to subject them to analysis, unless you so order.

The results obtained are a fraction less in some samples; in others they exceed a little. The deficiency is set down as loss incurred during the analysis, and the excess may be ascribed to the oxide of iron present being wholly or in part in the state of protoxide, but which is determined as peroxide.

---

*Analysis of twenty-one samples of Limes received from MAJOR R. H. SANKEY, R.E., Chief Engineer, Mysore.*

#### ANALYTICAL PROCESS.

*Comminution.*—Fragments of each sample were chipped off by a chisel hammer, the fragments enveloped in a towel, placed on an anvil and struck several times with a hammer. The particles so obtained were introduced into a steel mortar (such as is used in analysis) and crushed by repeated blows of a hammer.

*Pulverisation.*—The crushed particles were reduced to a fine powder by trituration in an agate mortar.

The *moisture* contained in each sample was determined by weighing 50 grains of the fine powder on a watch-glass and dried in a water-bath for several hours, re-weighed and the weighings repeated until the sample ceased to lose weight. The final weighing noted; the weight of the watch-glass deducted; the difference gave the quantity of *moisture* at 212° Fahrenheit.

The *dried* powder was next heated to a dull red heat in a platinum crucible for about ten minutes or longer; the change of color by heat noted; the crucible with its contents allowed to cool, and weighed; the weight of the crucible deducted from the total weight, the difference gave the quantity of *organic matter* and *moisture* not dissipated at 212° Fahrenheit.

*Separation of sand, clay and silica.*—Fifty grains of the powder treated with dilute hydrochloric acid in a beaker glass, the acid added in small portions at a time until effervescence ceased. The glass was covered after each addition of acid to prevent loss by spiriting. The hydrochloric solution was then evaporated to dryness, the residue mixed with water, a little hydrochloric acid added, gently heated and filtered. The portion insoluble in hydrochloric acid remaining on the filter thoroughly washed, the washings received into the filtered solution. The filter containing the *sand, silica* and *clay*, dried in a water-bath and weighed. The weight of the filter which was dried and weighed before-hand, subtracted from the total weight, gave the *sand, clay* and *silca* in the sample.

*Separation of iron and alumina.*—The hydrochloric solution of the previous operation was mixed with chlorine water, then with ammonia, and gently heated. The precipitate that formed was separated by filtration, thoroughly washed, the washings received into the filtered solution, the filter with the precipitate dried in the water-bath, the precipitate removed from the filter by rubbing it between the hands, the filter ignited, the ash returned to the precipitate, which was ignited in a platinum crucible and weighed. The weight of the crucible deducted gave *oxide of iron* and *alumina* in the sample.

*Separation of lime.*—The solution filtered after the separation of iron and alumina was nearly neutralised by hydrochloric acid, leaving the ammonia in slight excess, solution of chloride of ammonium added, and then oxalate of ammonia so long as a precipitate continued to form. The mixture set aside at a gentle heat for 12 hours and filtered. The oxalate of lime on the filter thoroughly washed, the washings received into the filtered solution, the filter with its precipitate dried in a water-bath, the oxalate of lime removed into a platinum crucible, the adhering portions scraped by rubbing the filter between the hands, the filter ignited, the ash returned to the precipitate, which was ignited and weighed. The weight of the crucible deducted, the difference gave *lime* combined with carbonic acid, the form in which the lime exists in the sample; 100 parts of carbonate of lime contain 56 parts of lime.

*Separation of magnesia.*—The filtered solution of the last operation was mixed with a little ammonia, and phosphate of soda added in excess, stirred with a glass rod and set aside for 12 hours. The granular precipitate that formed, consisting of basic phosphate of magnesia and ammonia col-

lected in a filter, washed with ammonia containing  $\frac{1}{4}$ th part of ammonia, dried in a water-bath, the precipitate removed from the filter ignited, the ash added to the precipitate which was ignited in a platinum crucible, allowed to cool, and weighed, the weight of the crucible deducted gave *magnesia* in combination with phosphoric acid. One hundred parts of pyrophosphate of *magnesia* contain 85.936 parts of *magnesia*.

*Carbonic acid.*—The carbonic acid was computed from the quantity of lime and *magnesia* found, and varified by determining in a few samples the loss on 50 grains by Hill and Fresinins' apparatus for analysing carbonates.

*Physical appearances of the Limes, and the effect of heat as regards color on them.*

No. of sample.	Physical appearances.	Effect of heat as regards color on them.
1	Massive, nodular grayish brown color with specks of gray interspersed through the mass, hard and compact, surface encrusted with a whitish brown matter, ... ..	No change.
2	Bivalve, covered with a mealy powder, yielding to the scratch of a nail, ... ..	Dull grayish white.
3	Nodular concretions, interposed with clay, grayish in the interior, whitish on the surface, ... ..	Grayish brown.
4	Fragments of a crystalline texture, whitish, with a light brown tinge, ... ..	Light brown.
5	Brownish gray masses, hard, surface irregular, encrusted with earth, ... ..	Ochre brown.
6	An irregular shaped mass, whitish on the surface, grayish within, ... ..	Dull gray.
7	Grayish white, irregular shaped masses, surface tuberculated, ... ..	"
8	Like No. 7, masses larger, ... ..	"
9	Whitish gray, oblong mass, with asperities on the surface, ... ..	Light gray.
10	A whitish friable mass, mealy on the surface, ... ..	Dull white.
11	Irregular shaped nodules of a grayish color, ... ..	Dull brown.
12	Whitish mass tinged with brown, in appearance like No. 10, but firmer in texture, ... ..	Light brown.
13	Brownish gray mass, with whitish incrustation, ... ..	Reddish brown.
14	Brownish gray mass, ... ..	Light brown.
15	Whitish brown, irregular shaped mass, ... ..	"
16	Slaty colored nodular masses, with a whitish incrustation, ... ..	Dull gray.
17	Gray colored mass with specks of white, ... ..	Light brown.
18	Whitish gray, irregular mass, ... ..	Grayish brown.
19	Light brown grayish looking mass, ... ..	Brown.
20	Whitish concrete, ... ..	No change.
21	Nodular masses of a whitish color, ... ..	Light brown.

ES.

14	15	16	17	18	19	20	21
1-700	1-500	1-600	1-600	0-800	1-200	0-800	0-800
0-900	1-000	1-200	5-800	0-600	1-200	0-700	0-800
6-000	8-400	36-600	30-400	3-200	35-800	4-800	4-400
2-600	2-600	6-000	10-800	1-300	7-000	0-200	3-000
48-872	48-048	29-908	21-840	52-080	30-456	52-416	50-400
1-180	0-430	0-860	7-760	0-788	0-214	0-286	1-004
38-546	37-976	23-946	21-223	41-331	24-135	41-337	40-125
0-202	0-046	...	0-577	...	...	...	...
100 000	100 000	100-114	100-000	100 099	100-005	100-539	100-529
86-200	85 800	53-400	39-000	93-000	54-600	93-600	90-000
1-798	1 305	1-305	11-823	1-199	0-325	0-435	1-529

Division.

look, Colar Division.

ision.

oor Division.

Hurryhur Road, Chittledroog Division.

enhully Talook, Bangalore "

oga Division.

l Talook, Toomkoor Division.

sipoor and Thagooroo, 3 miles from the former, Hassan Division.

hittledroog—

... ..  
 ... .. Not analysed.  
 ... ..







Dated 20th May, 1871.

The five specimens of lime-stones received with your letter No. 897, dated 26th April, 1871, were submitted to analysis; the following is a tabulated result exhibiting the composition of each specimen centesimally:—

Names of places where found.	Chickana- kenhully.	Major Johnson.	Linghully.	Burma- gherry.	Tirmul- poor.
No.	1	2	3	4	5
Carbonate of lime, .. ..	41.80	86.60	78.60	68.40	75.00
„ „ „ „ „ „ „ „ „ „ magnesia, .. ..	10.54	6.92	0.74	4.86	9.88
Sand and clay, .. ..	35.60	37.00	13.60	16.40	9.40
Iron and alumina, .. ..	5.20	11.20	4.80	7.80	5.80
Water, .. ..	5.00	7.40	1.00	1.60	1.00
Loss, .. ..	1.86	0.88	1.26	1.44	...
	100.00	100.00	100.00	100.00	100.58 excess.

The quantity of each specimen operated upon was 50 grains; the results obtained were doubled to express the centesimal quantity of each ingredient.

All the five specimens are poor as regards the quantity of carbonate of lime each of them contains, and all of them have an admixture of carbonate of magnesia. The impurities consisting of sand or silica, clay, iron and alumina, are considerable in all, being as much as 40.8 per cent. in No. 1, and 48.2 per cent in No. 2. No. 3 is the best specimen; it contains the largest quantity relatively of carbonate of lime, and a minute proportion of carbonate of magnesia.

These limestones, particularly Nos. 1, 2 and 4, if calcined with care, are likely to form *hydraulic cements*; the experiment deserves a trial, as they approach in composition, though varying in degree to the hydraulic cements used in Europe; a portion of Nos. 1 and 2 reduced to fine powder and heated to bright redness had the color of trass or puzzolana.

The quantities marked as loss in the analyses are very likely due in

part to the presence of potash and soda in the limestones, which were not specially searched for. Many hydraulic limestones contain potash or soda, or both in minute quantities.

---

*From*—LIEUT.-COL. R. H. SANKEY, R.E. *To*—P. DEJOUX, Esq.

*Dated 4th July, 1872.*

I am directed to enclose copies of the Analyses which have been already made of the limestones most commonly used in the Province of Mysore, and which Colonel Meade considers, so far as chemical analysis is concerned, supply all the information generally required by our Officers. Should, however, any large project be hereafter undertaken, your services in analysing the limestones in its neighbourhood will be gladly availed of.

I am, however, to say that if you could suggest any rough and practical test by which an Officer or Subordinate could, at his inspections of a work, decide whether the lime ready for use was fit for employment in ordinary building or not, the suggestion would be of great value. The area comprised in a division of this Province is very large, and the works not only small, but very numerous and widely distributed. The Inspecting Officer will therefore commonly visit several works in the course of a morning's shift of camp, and will probably not see them again until completed. At present his only test is to break down a part of the work already done in the case of works in progress.

In the case of works for which cement is required, such as foundations in the beds of rivers or streams, it would be most useful if you could suggest any apparatus, not chemical, by which an Executive Engineer could ascertain roughly whether a limestone was naturally hydraulic or not, and could furnish a drawing of a kiln for burning natural cements in very small quantities, which are what we have to deal with; also instructions regarding the actual preparation of the stones, whether it is indispensable to pulverize it before burning,—a process which necessitates the use of steam-power, and is therefore only practicable in the case of works of considerable size,—time and degree of heat to which to be exposed to, &c.

Mr. Norton's analysis of the five limestones on the 20th May showed that three were good natural cements, but our experiments showed that

only one (entered in list as " No. 2, Major Johnson ") furnished a cement which set readily under water on immediate immersion. It is probable therefore that the treatment of the other two limes should have been different. Should you be able to furnish the information requested in my last para., the Chief Commissioner will be obliged if you would indicate the limes in the lists furnished, to which it would be suitable.

I am to add that the results obtained from the cements of English manufacture purchased in the local market are invariably unsatisfactory, and I am therefore to enquire the distinguishing brand or trade-mark of the manufacturer you would recommend. Suggestions as to the best method of storing such cements to protect them from deterioration are also required.

---

From—P. DEJOUX, Esq., C.E., *Exec. Engineer, Cement Experiments Division. No. 112.*

*Dated, 30th July, 1872.*

I have the honor to forward my replies in juxta-position to the queries put by you.

In such a case it must be ascertained if the lime does not contain too

By what means is it to be known if a lime (fat or hydraulic proceeding from a quarry, producing stones, of which the chemical composition is known, and which produces good lime when properly treated) may be used in masonry works?

large quantities of either unburnt or overburnt portions, or if it is not mixed with too large a proportion of impurities as sand, &c.

For such a research it is sufficient to take a certain quantity, of which the weight or volume is known, put it into a vase, mix it with water, take out by decantation the water then containing the lime in suspension, add fresh water again, decant it, and continue going on in this manner until the water stands perfectly clear.

The portions such as unburnt or overburnt sand, &c., being heavier will remain at the bottom of the vase, so that by taking their weight or volume, the degree of impurity of the lime will be known.

If such portions are in pieces large enough to be separated from the lime by sifting through a finer sieve, it will only be necessary to sift them again. But if they are in too fine a state, or if they are in rather large proportions, the lime should be entirely rejected.

If, however, you are obliged to use this lime, it will be necessary in such

a case to reduce the quantity of sand in the mortar by a quantity three times larger than the volume of the impurities contained in the lime.

For instance, if with a lime of good quality you use a mortar composed of—

Sand,	...	... 2 parts,
Lime,	...	... 1 part,

you ought with a lime containing 25 per cent. of impurities to use a mortar made of—

Sand,	$[2 - (3 \times .25)] = 1.25$
Lime,	... 1.00

The *rich limes* (or fat limes) have their volume doubled (or more).

By what means can it be recognized if a lime (not hydraulic) proceeding from a stone of which the chemical composition is not known, is of good or inferior quality, that is to say, whether it is fat or meagre?

In slaking, they hiss, decrepitate, give out a great quantity of hot vapour, and fall in powder instantaneously or nearly so. By means of a sufficient quantity of water, they are transformed into a

smooth and fat paste.

The *poor limes* (or meagre limes) have their volume but little (or not at all) augmented by slaking; a certain time elapses before the slaking takes place, and it does so with little (or without) decrepitation; slight fumes are given out, but little heat disengaged. The paste made with them is rough, and has not such a binding power, and is not so unctuous as the paste made with the rich limes. When in powder, they seem rough to the touch.

The mode I think the best and which is certainly the most simple, is

By what means can it be recognized if a lime is hydraulic, and up to what degree?

the one shown by Vicat, and in which a small apparatus, called "Aiguille of Vicat" (Vicat's Needle)\* is used.

As, however, doubts on the efficacy of test by this apparatus have been expressed to me, I must say that all the *Ingenieurs des Ponts et Chaussées*, and those of the large Companies in France, enter always in their specification for hydraulic works, that the lime shall be tested by such an apparatus.

But as I have since traced amongst my papers two such specifications, one of the *Ponts et Chaussées*, and the other of the Paris Municipality, I translate the following extracts in support of my recommendation and argument for the use of the apparatus in question:—

\* *Vide Professional Papers on Indian Engineering, Second Series, No. LXII.*

## PONTS ET CHAUSSEES.

## RE-BUILDING OF THE BRIDGE LOUIS PHILIPPE IN PARIS.

*Specification.*

*Places from which materials ought to be obtained, and what quality is required.*

"The hydraulic lime procured from the Mancellerie, put under water, ought to support the weight of the Aiguille of Vicat four days after immersion. The hydraulic lime procured from the Moulineaux ought to support the Aiguille eight days after."

(Sd.) FELIX ROMANY,

*Ingenieur en chef des Ponts et Chaussées.*

---

II.—*Specification for the works of the Paris Municipality.*

"Act XXVII.—*Lime.*—The hydraulic lime will be either natural or artificial. The Engineers will accept the limes as hydraulic, which, when put immediately in water after being slaked, will set 12 days after immersion, that is to say, it will support without depression a needle of 0.0012m. of diameter, filed square to its end, and loaded with a weight of 300 grammes. Such limes are to be tested in such a way as many times as the Engineers may require."

(Sd.) DUPAIT,

*Ingenieur en chef du service Municipal de la Ville de Paris.*

Now, as it is mentioned in your letter, "that in this Province the works are not only small but very numerous and widely distributed, and consequently the Inspecting Officers can visit very seldom twice the same work," I think it would be advisable, under such circumstances, to make the Overseer in direct charge of each work send before-hand, either bi-monthly or monthly, a small quantity of the lime he is about to use, to the head-quarters of the Assistant Engineer, who could then and there test the lime himself by the process of Vicat above alluded to.

It is only necessary to build a small kiln which may be loaded with some pieces of the stone which are to be calcinated entirely by a moderate fire; you then ascertain that the calcination is complete when, pouring in a few drops of either hydrochloric acid or vinegar, no more effervescence takes place.

If the stones so calcinated do no slake when put in water, they may be cement stones, provided they contain clay in a proper proportion.

To ensure this, the stones are to be pulverized finely and tested, similarly as the hydraulic limes by means of the Aiguille of Vicat.

If it sets within one hour, it may be considered as a quick-setting cement.

If the setting does not take place after that time, the stone may be calcinated more strongly, so as to very nearly vitrify it, after which it is to be pulverized and tested as above described, and if it sets within 15 hours, it may be considered a slow-setting cement.

If the stone shows a pretty good homogeneity, it may be burnt in its natural state. But generally speaking, pulverize a cement stone before it is only necessary to pulverize the marly clays and stones of the same kind as the "ghooting" or "kunkur" found in Bengal.

Not having, however, received specimens of the stones, of which the analyses were only sent, it is impossible for me to state exactly in what manner they ought to be treated.

I cannot specify what quantity of fuel may be required for the burning of a cement stone; it varies so much according to the nature of the stone, that an idea can only be formed by experience.

I find it difficult, indeed impossible, to give an exact opinion about the quality of the stones of which the analyses were only sent to me, because the sand and clay having been weighed together, I cannot know one essential point in the composition of a cement stone, viz., the proportion of sand.

I will explain this impossibility by an example. If the analyses of three different stones, which I will call A, B, and C give the following results :—

		Carbonate of lime, &c., &c.,	...	...	...	...	...	70.00
A	{	Clay,	...	...	...	...	10	30.00
		Sand,	...	...	...	...	20	30.00
								Total, ... 100.00
								Total, ... 100.00
		Carbonate of lime, &c., &c.,	...	...	...	...	...	70.00
B	{	Clay,	...	...	...	...	17	30.00
		Sand,	...	...	...	...	13	30.00
								Total, ... 100.00
								Total, ... 100.00
		Carbonate of lime, &c., &c.,	...	...	...	...	...	70.00
C	{	Clay,	...	...	...	...	28	30.00
		Sand,	...	...	...	...	2	30.00
								Total, ... 100.00
								Total, ... 100.00

it will be seen that the total amount of clay and sand is the same in the

three stones. Notwithstanding, A will yield a meagre lime of very inferior quality, which ought to be generally rejected; B a very hydraulic lime, but which, containing a rather large proportion of sand, must be used in the mortar with less sand than otherwise; C must be taken as a good cement stone, because it contains a proper proportion of clay, and less than 5 per cent. of sand. It is admitted that stones containing more than  $\frac{1}{10}$ th part of sand yield cement of inferior quality, and are generally to be rejected.

To give an idea of the enormous proportion of sand which may be found in a limestone, I will quote the result of an analysis I made on a limestone from the Girhilee Road Division (1st Presidency Division, Bengal).—

Carbonate of lime,	...	...	...	...	...	...	...	41.60
" magnesia,	...	...	...	...	...	...	...	trace.
Oxide of iron,	...	...	...	...	...	...	...	2.90
Clay { Silica,	}	...	...	...	...	...	...	22.50
Alumina,								
Sand,	...	...	...	...	...	...	...	33.00
							Total,	100.00

If admitting that the proportion of sand in your analyses of the 20th May does not exceed 5 per cent, the only stones which may be cement stones are those marked Nos. 1 and 2, while No. 4 does not contain enough clay.

The rather large proportion of magnesia which No. 1 contains, may have been the cause of the failure noticed; however, by calcinating this stone with a very slow fire, a cement of good quality may be obtained.

It may, perhaps, be better not to calcinate it entirely, and thereby to leave in it a feeble quantity of carbonic acid.

In the table of the analysis of 21 samples, the stones marked Nos. 3, 5, 6, 9, 16 and 19 may also be cement stones, by observing the same restriction as regards the sand.

The one marked No. 17 is doubtful on account of the large proportion of oxide of iron, and No. 13 contains too much clay.

I cannot furnish more precise instructions on this subject, *first*, for the reason already adduced; and *secondly*, because it is almost impossible to pronounce on the mode of treating a cement stone without having seen it.



The best and only one of all the cements imported into India I would recommend, is that manufactured by Messrs. White Brothers. I have used in India about 10,000 casks of it, and I may safely say that I never had any occasion to complain about its quality.

A precaution in the purchase of this description of cement is requisite. This consists in buying only the casks made of oak, because Messrs. White Brothers, in order to make a small reduction in the price at times, export in casks made of pine-wood. These latter not being strong enough, generally give way in loading or unloading, and consequently the contents get spoilt very soon.

When the cement in stock cannot be used up immediately, it is advisable to apply to each cask a coat or two of coal-tar. The casks should be put on joists resting on small brick-walls of about one foot high. Besides, it is not advisable to put the casks against the walls of the godown in which they may be stored.

P. D.

## No. CII.

## NOTES ON THE MULTAN INUNDATION CANALS.

[*Vide* Plate Nos. VI. and VII].

By E. A. SIBOLD, Esq., *Exec. Engineer, Sirhind Canal.*

THE numerous traces of old canals with their countless branches, and the frequent pottery mounds, show that the Multan wastes must at one time have been well populated and highly cultivated. On the borders of the waste nearest the Chenab, the present cultivators are from the N. E., the more highly cultivated lands on the river banks are chiefly owned by men whose ancestors crossed the Indus, and in other cases by Hindus, who have dispossessed them since the Sikh and British rule; but these modern Multanees claim no relationship with the men who constructed the ruined canals and towns and villages; nor, except in the case of a few isolated tombs of Mahommedan martyrs, have they any traditions about them. In Canal Engineering it is an interesting question whether want of science or the successive invasions of the Mahommedans have led to the conversion into waste of 1,400,000 acres out of the total of 1,800,000 acres of soil in this district. Not many centuries ago the district was intersected by the Beas, Ravi, Chenab, and Sutlej, the two former now join the latter higher up.

There are two sets of canals—the Chenab and the Sutlej—the Chenab canals only irrigate a strip of land on the river bank, varying in width from 2 to 7 miles, but that strip owing to the canals being supplemented by the wells, is as well cultivated as the most favored district in the Punjab. In the Shujáhábád Tehseel, the greater portion of which is owned by Hindus, a number of estates have 12 to 16 out of 24 acres constantly

under cultivation. The Sutlej canals irrigate as far as from 15 to 20 miles from the river bank, but owing to the carrying powers of the channels being small, compared to the large extent of country traversed, the cultivation appears in isolated patches. These canals owe nothing to the British Government, beyond a definite procedure in enforcing water-rights and systematic annual clearances. A description of the Multán Canals is chiefly useful in showing what should be avoided in designing irrigation works. Many of the points touched upon would appear to be more in the province of the Magistrate and Collector, but it is not as in a railway, where the Engineer is given a definite plan to work upon, and left to cope with the Engineering difficulties only; the Canal Engineer has to consider the revenue as well as the Engineering points, and to learn to appreciate the necessities of the cultivator.

The works of Spain, Italy, and France teach but little, because their largest plains are but fields compared to the extensive level tracts of Northern India; canals in India are chiefly important from their magnitude.

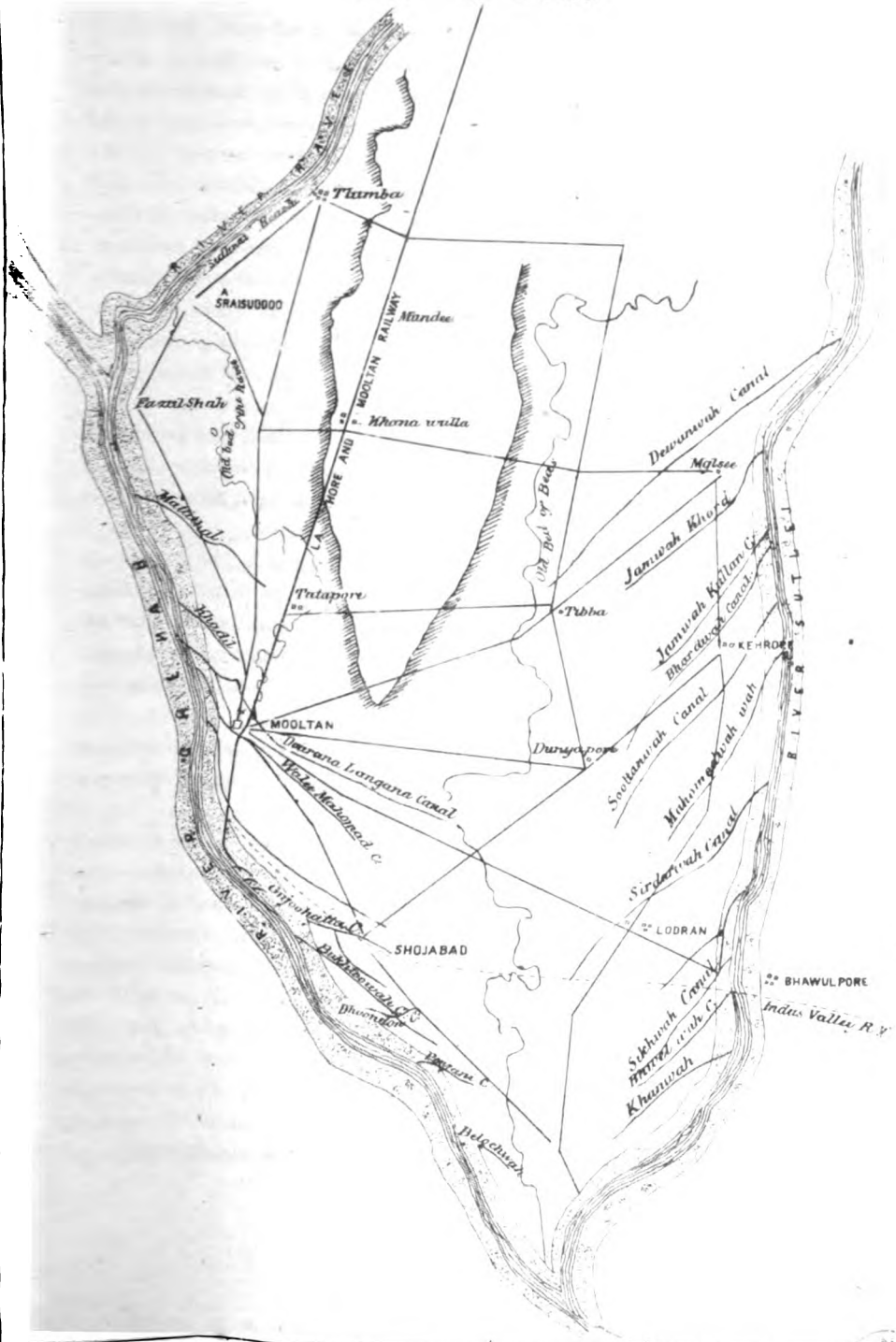
The district of Multán is essentially an agricultural one. It possesses no building materials beyond good brick clay, and the distances from which lime and stone have to be brought, account for the absence of ancient buildings dating from before the invasion of Mahmoud of Ghaznee. Greek and Hindu coins are often found in canal excavation, but little information can be deduced from such by any but experts.

It is a difficult question to determine whether the numbers that once inhabited Multan were decimated by gradual physical changes, or were the victims of crushing disasters.

Doubtless the Mahomedan invasions were one cause of the decline of Multán, and it is probable that the other cause was that irrigation ultimately became too expensive, owing to silting due to vicious alignment of channels and absence of systematic distribution. Present experience shows that in some cases the expense of silt clearance may make the burden of maintenance too intolerable to be endured, but as in these canals, the slopes were often favorable, such a complete and apparently sudden collapse must have been caused also by the inroads of the early Mahomedan invaders, the wantonly destructive nature of whose successes would render the blotting-out of a people dependent for their very life on artificial irrigation, a matter far from difficult or improbable.

THE MULTAN INUNDATION CANALS.

Scale. 16 miles = 1 inch





Though the Engineering defects are patent, there are points in the climate, and the customs of the people worth consideration. In the tract irrigated by these canals, the spring level (except on the Dourana Langana) is no where more than 20 feet, and very often is not more than 15 feet below natural surface. The excessive dryness of the climate appears to make well irrigation unremunerative, even when the spring level is only 15 feet below ground. The sediment in the canal water fertilizes the ground, for the cultivators often petition for permission to spread the silt banks over their fields. Every plot has a well, and the owner works it too, but the supply thence is looked on as only supplementary to the canal supply. Splendid rubbee crops are grown, but only on grounds well saturated by the canals during the hot weather, supplemented by one or two waterings from the wells in the cold weather. It is marvellous that the people are so healthy, and that malaria does not prevail, considering that during the irrigating season, the canals convert the tracts they traverse into sheets of water, and stop all communication on all except two high roads. The absence of malaria may be due to the canals not being perennial.

At first sight it appears perplexing how to manage the distribution when water is most wanted at the first ploughings, and again when the crops are maturing, whereas the rivers are at their highest, and water most abundant in the middle of the season. The Hindus and most of the cultivators on the Chenab meet this by a timely working of their wells, but the improvident Belochees on the Sutlej cultivate to an extent that the whole crop can only be matured in very favorable years. The fluctuations of the supply give the irrigators at the tail of a canal a great advantage over those in the middle reach; remodelling would clear away this disadvantage, and then there would be no inducement for the irrigators of the middle reach to sacrifice the economical slope of the canal to favor themselves.

The difference between highest flood level and lowest level in the Chenab is 12 feet. The maximum rise of the Sutlej appears to be the same from where it leaves the hills at Rúpar, to its junction with the Chenab. The same may be said of the Ravee and Beas; in fact the maximum rise where the Punjab rivers (excepting the Indus) are working in beds of loam and sand may be taken at 12 feet; it never exceeds 13 feet. The Ravee in the Sidnai has a maximum rise of 11 feet, and the Beas a little less

50 miles above the Delhi Railway Bridge. A comparison of several cross sections gives roughly as the cross-section of the Sutlej valley on the right bank (*Fig. 1, Plate VII.*); any striking departure from this general section would on investigation be found due to sand hills and local depressions and elevations. In the alignment these mounds make a difference in the amount of earthwork, but do not vitiate the power of the canal, to irrigate by gravity.

The popular idea is that the rivers destroy in the most sudden and unaccountable manner the heads of the inundation canals, and that the supply from them is most precarious.

The canal heads are fairly stable, and exceptional cases of disaster may be traced to causes that might have been remedied or avoided. Remedies are possible but not practicable, partly because there is not time to work out the details of each individual accident, but chiefly because the canals are too insignificant to bear the burden of extensive alterations. The supposed advantage of having numerous small canals taken from the river independently is that failures are not likely to be so disastrous. When, however, the river destroys one of these small canal heads the local disaster is complete, and in those cases where two canal heads are dug one along side the other, so that if the river affects one, it necessarily affects both, the disaster is aggravated and becomes more general. Erosion and silting are the causes, and the one necessarily accompanies the other, and the equilibrium of the river is being constantly disturbed by the former, and adjusted by the latter. In canals, the side silting is invariably considerably higher than the highest flood mark. This may be due to the washing down of the water slopes by rain, except in cases where the maximum supply at any time comes down in a wave, and rolls up the side slopes, leaving on returning to its real working level the heavier sediment. In rivers, the curves are necessarily in some part broadside on to the current, and the sandbanks thus formed are found to be often considerably higher than the maximum rise, and the sediment is thrown higher than the highest waves on the slope, owing to its superior momentum. An examination of the surface levels of rivers in flood at different points would give some data, and explain a great deal now thought inexplicable.

Two miles below Tolumba, the Ravee passes through a hard stratum of clay for 9 miles on a slope of about 4 inches to the mile. In this reach it is quite straight, the high banks are from 410 to 420 feet apart,

THE MULTAN INUNDATION CANALS.

Fig. 1.

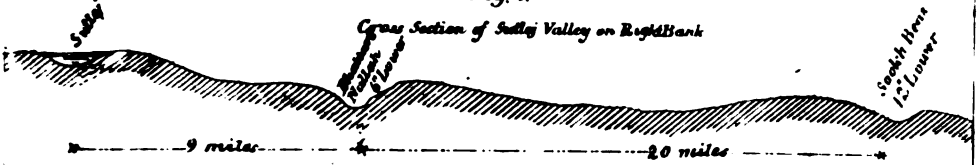


Fig. 2.

Working of Deep Stream

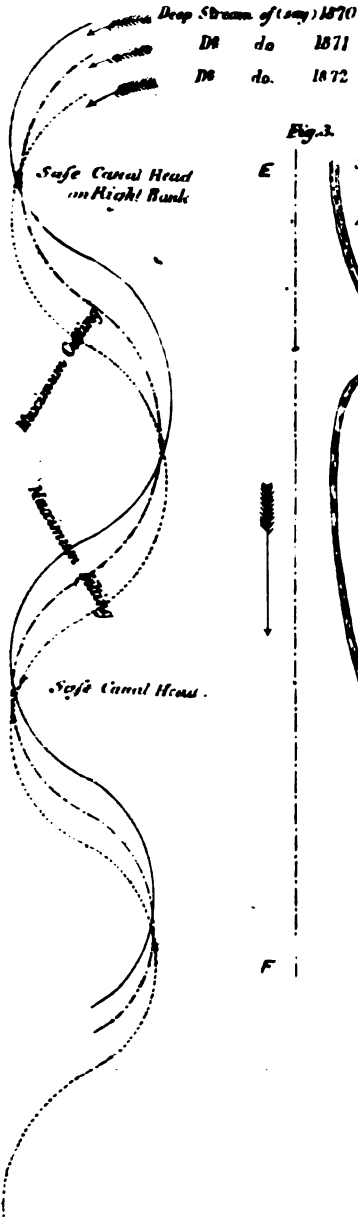
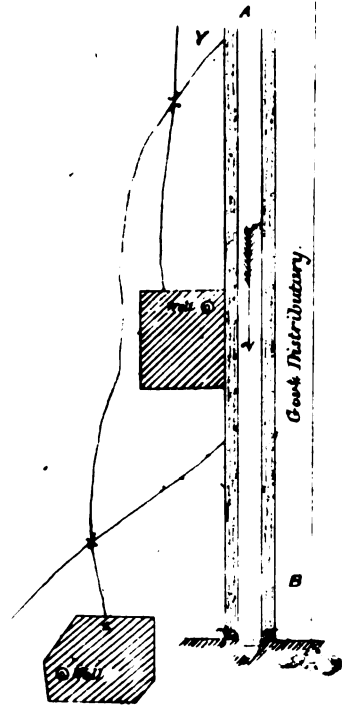
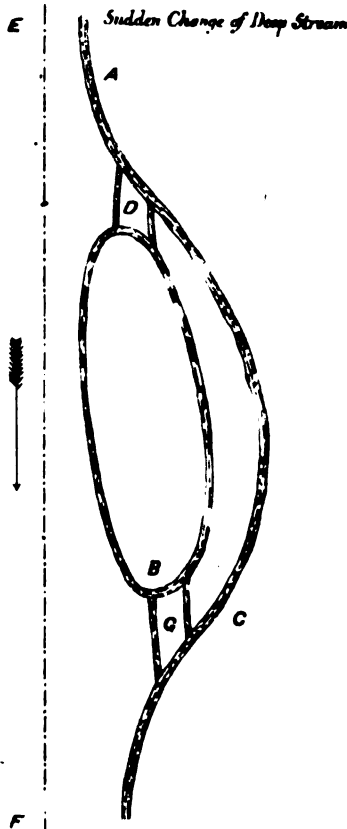


Fig. 4.

Length of Private Water-Course

Fig. 3.







and covered with magnificent trees dipping their branches in the water. This straight reach, which is called the Sidnai, looks like an artificial canal. After leaving this, the river, as before entering it, winds about in loops that give its course at least 2.5 times the length in a straight line. Formerly after leaving the Sidnai it flowed past Multán. This course has been abandoned, and it now (by turning to the N. W.) joins the Chenab, about 70 miles higher up. This change in its course must have occurred some time after the first Mahommedan invasion, as on the old course there are the remains of Mahommedan tombs; one is a very extraordinary building, containing Hindu and Persian inscriptions. The levels show that it is quite possible, and by no means improbable for the Ravee to change its course to the south by Tolumba, and again flow past Multán. The fall in this direction is nearly 2 feet a mile, and spill water in ordinary floods finds its way down 20 to 30 miles, and a very high and sustained flood is quite capable of scouring out a permanent bed on this line. It is strange that the river traverses the high land of the Sidnai in preference to this line. The Hindus explain it by a reference to Rama and Seeta, and the Mahommedans believe it to be the work of some king. It is improbable that it was an artificial cut, as there is no spoil. If the soil had been more friable, and the course winding, it might have been attributed to the river enlarging a canal cut, and sweeping the banks of the smaller channel before it. It is, however, rare to find erosion without winding in a stream.

On the Beas nullah there are remains of second banks, forming as it were a step up to the general level of the ground. In places, regular ridges as of spoil may be traced on the old Beas, and its branch nullahs. Are these gigantic attempts at silt clearances to keep the river and the nullahs from deserting these channels? The channels as would appear from these second steps, have gradually *contracted in width* by deposits where current was slack; the process remaining in many cases half completed by total desertion of their beds. The late Col. Anderson noted this fact in silting.

A little acquaintance with the working of the rivers gives rise to the idea, that there is an oscillation of the deep stream that works slowly up and down each river. The intensity and the direction of the oscillation in a given length varying with quality of the river banks and its declivity. The distance travelled by this oscillation in one year will give the maximum

distance of safety between two canal heads—*i. e.*, when one is damaged the other is untouched, so if both discharge into the same channel, the irrigation is almost a certainty (*Fig. 2, Plate VII.*) On the Sutlej the distance between two canal heads should not be less than 3 miles, and on the Chenab not less than 5 miles, though the latter is the more stable river. The above includes a vibration in the width of the river—*i. e.*, the deep and eroding stream first works on one side, and then on the other. The people believe, and there are facts to support it, that the Punjab rivers are all working to the West. If true, it is so gradual, that it may be neglected. It would affect inappreciably the question of the utility of permanent works. We may therefore assume that all works beyond the limits of vibration in the widths of the rivers are not affected by their changes, and can therefore be looked upon as well worth permanent improvements. On the Chenab all land beyond one mile from the high bank of the river may be said to be entirely out of its influence. On the Sutlej about three miles would be the safe limit. On the Sutlej if there were three canal heads each three miles from the other, and feeding the same trunk line, this trunk line being three miles from the high bank of the river, we have

- (a). In one year it is probable that one of the three heads may work badly or become useless; it is possible that a second one might be damaged, but improbable that the third one should share the same fate.
- (b). Accidents to any of the heads could be foreseen, and remedies possibly applied, because we should have only to watch the changes in 15 miles of river bank.
- (c). Permanent improvements could be carried out on the trunk line and its distributaries, and the revenue arrangements could be settled once for all. On the Multán canals, it is a mere matter of arithmetical calculation and convenience as to the way in which the existing canals should feed from a permanent trunk line, and their old heads be gradually abandoned.

This excludes sudden changes of the river due to the following cause (*Fig. 3, Plate VII.*) ADG is the deep stream of the river with a branch DCG. The deep stream shifts to the line EF, silting up area AEF, and throwing bars of silt across the branch at D and G. In course of time DCG is ploughed over, and becomes only perceptible as a local hollow. Again the deep stream shifts, cutting away the bank EADF, and in flood

sending a wave down DCG, which topping the silt bar G, may cause a scour sufficient to ensure that being the line of the deep stream for the future, and transferring bodily standing crops on B to the other side of the river. If the fall between D and G is considerable, the results will be most disastrous. This is no imaginary case, as the records of alluvion and diluvion in the courts will show. A careful examination, however, of the country will easily show where only such accidents are possible.

The substitution of a relatively few definite heads give—

(i). *Effect of Widening.*—Take the case of a 5 foot and 10 foot width of bed, both having vertical sides and the same declivity, the discharge of the latter will be two and a half times that of the former, though the excavation will be but double. The 30 foot channel gives nine times the discharge for six times the excavation.

(ii). *Effect of Declivity.*—A channel discharges 1·707 times the volume on a slope of 1 in 5,000, than it does on a slope of 1 in 10,000.

(iii). *Effect of deepening.*—

Width of bed, .. .. .	18 feet.
Side slopes,.. .. .	½ to 1.
Declivity, .. .. .	1 in 7,500.

A depth of 5 feet of water gives a discharge of 200 cubic feet per second; of 10 feet, 571 cubic feet. It would be useful to work out the ratio for the sizes of channel usually adopted on Indian canals.

(iv). The cost of survey and Engineering establishment diminishes relatively as the magnitude of a work increases.

(v). *Less length of river to be watched.*—The length of river channel to be watched being limited, the fixed establishment would speedily acquire a thorough knowledge of all the possible changes of the current, and be able to make arrangements in good time to overcome all difficulties.

As no two men have the same opinion about river works, and there is no possibility of laying down rules absolutely correct and fitted for all particular cases, it is easy to see that, without this thorough local experience, the majority of hasty and temporary attempts to train the river by spurs and bunds would be sure to fail.

If a country becomes highly cultivated, many of the minor drainage lines

disappear. This has occurred in several instances on the Barea Doab Canal. In the Multan district the drainage has little or no relation to the contour of the country. The only important drainage is from the high land or "bar," where nearly the whole of a heavy fall of rain is shed on to the river valley. The wastes of the high land are covered with scrub jungle on mounds with rounded depressions between, thus giving the greatest facilities for passing off the rain.

The canals from both rivers begin to work about the end of April and run dry about the end of September. The canals are simply open trenches taken from the river, and unprovided with regulating works of any kind. It is generally the most judicious plan to start the canal head from a creek or back water of the river. Floods affect canal and river equally, but it is a curious fact that serious damage is rarely caused by a flood down a canal. The violence of the river floods are tempered by the tract of sandy low land that intervenes between where the Multan canals take off, and the point where the river issues from the hills. In the canal, this is further tempered by the numerous open private cuts, and on the Walli Mahomed canal which passes Multan city 20 miles from its head, the gauge at Multan did not vary more than a few inches in 3 months in 1872.\* Below Multan the depth of water in this canal is almost as certain as in canals provided with regulating works. The serious difficulty at present is when the river rises and falls early. This could be arranged for by providing more than the average waterway by supplementary heads worked when needed.

The defects are—

- (i). Bad alignment owing to influential landholders naturally seeking their own benefit.
- (ii). Want of longitudinal slope. Any improvement of this would be strongly resisted by those whose lands would suffer near the head of a canal by the lowering of the water level.†
- (iii). Intricate net-work of channels that has grown up during centuries. The cause of this can be understood from (*Fig. 4, Plate VII.*) AB is a canal, but the water level at B is below plot X, so the owner runs his cut up to y to get the neces-

\* Very bad floods are met by breaching the canal bank on the river side at any convenient point. Such a method is only possible where a Native Government introduced irrigation.

† On two Canals the bed level was the same at head and tail. The take-off was the sole cause of these Canals working.

sary head. The results when such plots can be counted by hundreds on a canal can be imagined. Some water-courses run parallel with five or six others for from 6 up to even 12 miles. It is strange that the Multanees never put a canal into embankment. On the old Husli canal which the Bares Doab canal superseded, there is one rather heavy embankment near the town of Majhita.

*(To be continued.)*

E. A. S.

## No. CIII.

### EARTHWORK IN SIND.

BY W. H. PRICE, ESQ., *M. Inst. C.E., Superintendent, Kurrachee Harbor Works.*

*Memorandum and Table of Tasks, also some account of System on Eastern Narra Supply Channel.*

THE subjoined Table is based chiefly on data gathered when in charge of the Eastern Narra Supply Channel Works, near Roree in Upper Sind, during the years 1856-58.

The data are as follows :—

1st.—That an able-bodied laborer, (Sindee,) accustomed to earthwork, can excavate and fill into a basket 320 cubic feet of alluvial soil, in a day of 9 hours.

2nd.—That a similar laborer can, on smooth level ground, go a distance of 80 feet with a loaded basket, (holding about two-thirds of a cubic foot of earth, measured in "situ,") and return the same distance with the empty basket, while the excavator is "getting" and filling another basket.

3rd.—That each foot in height to which the material is raised, is equal to 7 feet of horizontal distance.

4th.—That the inclination of the runs should not be greater than 1 in 10, otherwise the man cannot carry the full weight, so as to work to advantage. At the above inclination, the "stage" should be 47 feet or about three-fifths of the length on a level.

Thus, in addition to the man for "getting" and filling, each foot of "lead," measured horizontally, requires one-eightieth of a man's labor, and for every foot in height, 7 feet is to be added to the horizontal distance.

*Example.*

“Lead” measured (horizontally) along the line by which the material is to be conveyed, ... ..	70 feet.
Height to which material is to be raised—say 5 feet,—× 7 =	35 „
Total, ... ..	105 „

$$\frac{105}{80} = 1.31 \text{ men.}$$

Add getter and filler, ... .. 1 „

Total No. of men required, ... .. 2.31

$$\frac{220}{2.31} = 139 \text{ cubic feet} = \text{task for one man.}$$

The quantities given in the Table, multiplied by the current rate of wages of the District, will give the cost of the work for labor, including use of “phouras,” which the men found for themselves on the Narra Supply Channel, or paid 3 pies daily for hire of one from Government.

In estimating the entire cost of such work, the following items, (based mainly on practice at the Narra Supply Channel,) should be added to cost of labor as above :—

	Per cent.
Cost of baskets (and loss on wheel-barrows when such were used), .. .. .	6
“Tarwallahs,” <i>i. e.</i> , laborers for levelling and dressing spoil banks, one allowed to every 50 men, at same rate of pay,	2
Dressing slopes of cutting, <i>see</i> next page, .. .. .	1½
Muccudums (gangera) one allowed to every 50 men, at same rate of pay, .. .. .	2
<i>Supervision, exclusive of Engineering Establishment.</i>	
To every 500 men, on an average, were allowed—	
1 Head moonshee or “darogah,” at per mensem, .. Ra.	25
3 Assistant moonshees, at Rs. 10 each per mensem, .. „	30
1 Jemadar, .. .. .	10
1 Shroff for daily payments, .. .. .	10
Share of storekeeper and store expenses, about, .. „	10
Total Rs., .. .. .	85
which, on the work of 500 men for 26 days in the month, at 3 annas daily wages, amounts to .. .. .	3½ „
Total,	14½ per cent.



If phouras had been supplied to the men on the Narra Supply Channel, their cost would have amounted to about  $2\frac{1}{2}$  per cent. in addition.

The above percentage rates would not all apply to small channels, on which the rate for dressing slopes would be higher; the Narra Supply Channel was 155 feet wide at bottom, and on a channel 30 feet wide the sloping would be 7 per cent. Also supervision would be more costly, owing to the greater proportionate length of the line.

At the utmost, however, the total percentage on cost of labor should not exceed 25 per cent., which was the amount allowed to Contractors on the Ganges Canal (*vide* Sir Proby Cautley's Report, Vol. II., pages 557, 558) to include levelling and smoothing off embankments, finishing slopes, and provision of tools.

In applying the subjoined Table to canal clearance work in Sind, allowance should probably be made for extra labor (in taking out scattered and small portions of excavation) as compared with new cutting.

As regards this, however, officers who have had experience on canal clearance (of which I have had none) would be better qualified to judge.

*Table showing number of cubic feet of Earthwork which an able-bodied laborer (Sindee) can execute in a day of nine hours in the alluvial soil of Sind.*

Height to which the material is raised, i. e., average height of spoil bank + average depth of cutting.	"Lead," in feet, measured horizontally along the line by which the material is conveyed.																
	10	12	15	18	20	25	30	35	40	45	50	55	60	65	70	75	80
Feet.	c.ft.	c.ft.	c.ft.	c.ft.	c.ft.	c.ft.	c.ft.	c.ft.	c.ft.	c.ft.	c.ft.	c.ft.	c.ft.	c.ft.	c.ft.	c.ft.	c.ft.
1	264	258	252	244	239	229	219	211	201	194	187	181	174	168	163	158	153
2	---	---	---	---	224	215	206	199	190	184	178	172	166	161	156	151	147
3	---	---	---	---	---	---	195	188	181	175	169	164	158	155	150	145	142
4	---	---	---	---	---	---	---	---	172	167	162	157	152	148	144	140	136
5	---	---	---	---	---	---	---	---	---	---	155	151	146	142	139	135	131
6	---	---	---	---	---	---	---	---	---	---	---	---	140	137	133	130	127
7	---	---	---	---	---	---	---	---	---	---	---	---	---	---	129	125	123

Height to which the material is raised, i. e., average height of spoil bank + average depth of cutting.	"Lead," in feet, measured horizontally along the line by which the material is conveyed.															
	80	90	100	110	120	130	140	160	180	200	220	240	260	280	300	
	c.ft.	c.ft.	c.ft.	c.ft.	c.ft.	c.ft.	c.ft.	c.ft.	c.ft.	c.ft.	c.ft.	c.ft.	c.ft.	c.ft.	c.ft.	c.ft.
8	119	113	108	104	100	96	93	86	81	76	72	68	65	62	59	
9	—	110	105	101	97	93	90	84	79	75	70	67	63	60	58	
10	—	—	103	98	95	91	88	82	78	73	69	66	62	59	57	
11	—	—	—	96	92	89	86	81	76	72	68	64	61	59	56	
12	—	—	—	—	90	87	84	79	74	70	67	63	60	58	55	
13	—	—	—	—	—	85	82	77	73	69	65	62	59	57	54	
14	—	—	—	—	—	—	81	76	72	68	64	61	59	56	54	
15	—	—	—	—	—	—	—	74	70	67	63	60	58	55	53	
16	—	—	—	—	—	—	—	73	69	65	62	59	57	54	52	
17	—	—	—	—	—	—	—	—	68	64	61	58	56	53	51	
18	—	—	—	—	—	—	—	—	66	63	60	57	55	53	51	
19	—	—	—	—	—	—	—	—	—	62	59	56	54	52	50	
20	—	—	—	—	—	—	—	—	—	61	58	55	53	51	49	

NOTE.—The smallest lead allowed for in the above, is ten times the height to which the material is raised, so as to allow for a proper inclination of "run," see page 48.

*System on Eastern Narra Supply Channel.*

The following particulars relative to the works of the Narra Supply Channel, under the excellent system organised by Lieutenant, (now Colonel,) Fife, R.E., in 1853-54, may prove interesting and useful in connection with the subject of Earthwork.

This channel was a new cutting 13 miles in length, chiefly in alluvial soil, opening from the left bank of the River Indus just above the town of Roree.

The bottom width was 155 feet, average depth 15 feet, and side slopes generally 1½ horizontal to 1 vertical; on either side the spoil was deposited in a bank about 200 feet wide by 8 to 10 feet high, leaving an interval of 15 feet between the bank and the cutting, to serve as a berm or towing path.

The cutting was divided into lots of 100 feet in length, at the extremity of each lot a ramp 10 feet wide was left for ascent and descent. The earth between the ramps was then removed in layers of  $1\frac{1}{2}$  foot thick, until the requisite depth was attained, after which the sides of the channel were dressed to the proper slope and the ramps removed.

The excavation was carried out by task-work, the daily tasks being marked out in widths of 2 feet, and lengths proportionate to the quantity, which varied of course with the depth.

A tin-ticket was given to every man who completed his task, and these tickets were cashed for wages on presentation to the Shroffs, who went along the channel for this purpose, each afternoon.

In this way the trouble of muster rolls for many hundreds of workmen who were constantly changing was dispensed with.

Under the task-work system also no restriction as to hours was necessary, and in the very hot weather much of the excavation was done at night.

The excavation was done by means of "phouras" (hoes), and the material was put to spoil chiefly by means of wicker baskets.

The able-bodied men in many cases brought their wives and families to assist them; thus one man, his wife, and three children would, perhaps, take three men's tasks.

Wheel-barrows also were considerably used by the able-bodied single men, who did one-sixth more work for the same money than those who used baskets. The gain in this way did not quite pay for the extra cost of the barrows, but it paid in time, by enabling 6 men to do the work of 7, and so causing a saving in establishment, and expediting the completion of the work.

Donkies were also used (chiefly by the migratory class of laborers called "Oades") for conveyance of the spoil.

The small country carts each drawn by a pair of bullocks, were also considerably used, but these as well as the donkies did not work deeper than about 12 feet, below which the ground was moist.

The cost of these different methods of working was much the same.

The men as above stated found their own phouras, or paid 3 pies each for the hire of one daily.

They were found in baskets and wheel-barrows, but paid a portion of the cost of the latter—as already stated—by doing one-sixth more work than with baskets.

The tasks did not include the dressing of the side slopes or of the spoil banks.

The spoil banks were formed by commencing to deposit the material at the outer edges, so as to make the "lead" as equal as possible throughout.

The embankments not being liable to any heavy pressure of water, this method of forming them answered well; but had it been necessary to consolidate them quickly, it would have been requisite to form them in layers, commencing next the cutting, so that each layer would have been consolidated by the trampling of the people, and by the wheels of the carts.

This last method of proceeding would of course have involved greater cost.

The daily rate of pay for one man's task was  $2\frac{1}{2}$  annas from 1853 to 1855, when it was raised to 3 annas, and finally in 1858 to 4 annas.

The channel was opened in 1859.

The donkies' rate of pay was the same as that of the men, and the rate of carts, including one excavator with each, was as 11 to 3, compared to a man's wages.

The scale of tasks was as follows:—

*Basket Work.*

No. of layer, each $1\frac{1}{2}$ feet deep.	Task for one man.	LENGTH.		BREADTH.		DEPTH.	
		Feet.	Inches.	Feet.	Inches.	Feet.	Inches.
1st and 2nd, ..	Cubic feet. 70	23	4	2	..	1	6
3rd and 4th, ..	65	21	8	2	..	1	6
5th and 6th, ..	60	20	..	2	..	1	6
7th and 8th, ..	56	18	8	2	..	1	6
9th and 10th, ..	52	17	4	2	..	1	6
11th and 12th, ..	48	16	..	2	..	1	6

For wheel-barrow work, the tasks were, as already mentioned, one-sixth in excess of the above; and for each cart, the task was to a basket task as 11 to 3.

MANORA, }  
21st June, 1873. }

W. H. P.

## No. CIV.

---

### CIVIL BUILDINGS, LAHORE.

[Vide *Plate* Nos. VIII., IX. and X.]

---

*Designed by* W. PURDON, ESQ., M. INST. C.E., F.G.S., *Supdg. Engineer.* *Built by* RAI KUNHYA LAL, *Assoc. Inst. C.E., Exec. Engineer.*

---

THE building is situated on the Mall, Anarkullee, on the high ground opposite the Presbyterian Mission Chapel.

The principal facade is 233 feet in length, the breadth being  $61\frac{1}{2}$  feet. This part is double-storied, the lower  $18\frac{1}{2}$  feet, and the upper 17 feet in height.

The wings which have a single story only, are each  $166 \times 51$  feet by  $18\frac{1}{2}$  feet in height.

The masonry, throughout, is pukka, of the best description, faced with dressed bricks, set in proper bond; the mouldings over pillars, arches, doors, windows, being in cut bricks.

The foundations are 6 feet deep, 3 feet of which consist of the best concrete, well consolidated.

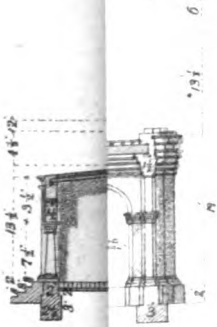
The floors consist of square tiles  $12 \times 12 \times 2\frac{1}{2}$  inches, set in lime or concrete, with close joints.

The main roof consists of lime terrace, over square tiles, laid on kurries and trusses of deodar wood; the verandahs have also, the same description of roof covering, over kurries and beams, the latter being in continuation of the rafters of the main roof.

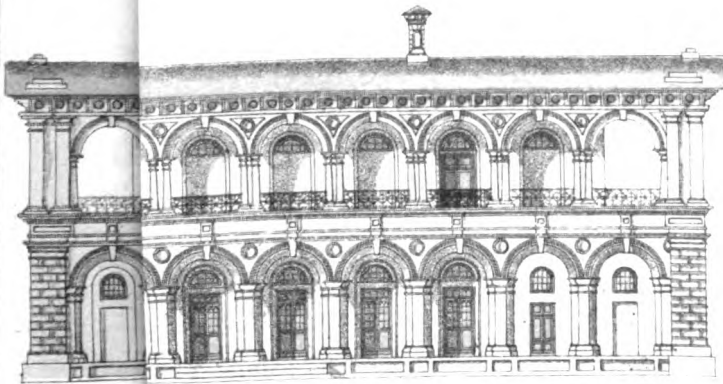
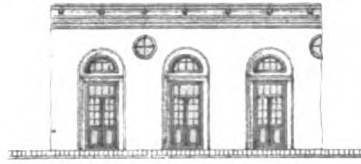
The floors of the upper rooms, which are used as Record Rooms, consist of 2-inch deodar planking, over kurries and beams of the same wood.

18.

Engineer.



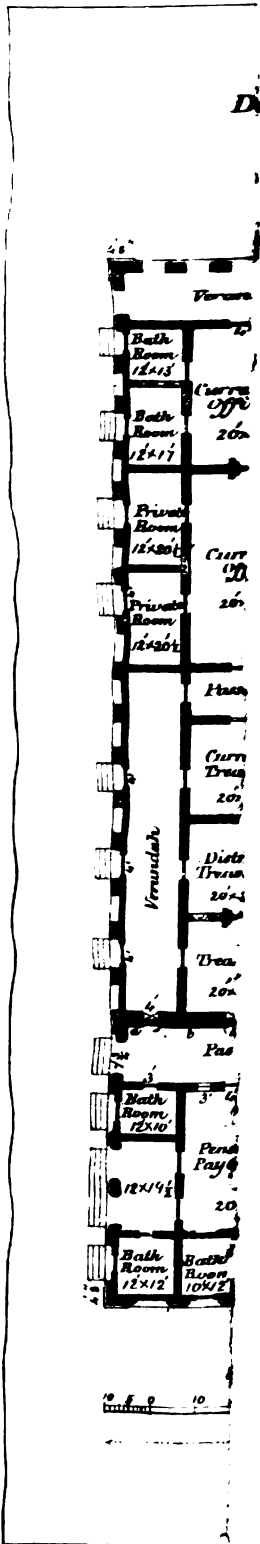
PART OF LONGITUDINAL SECTION OF VERANDAH.



50 feet









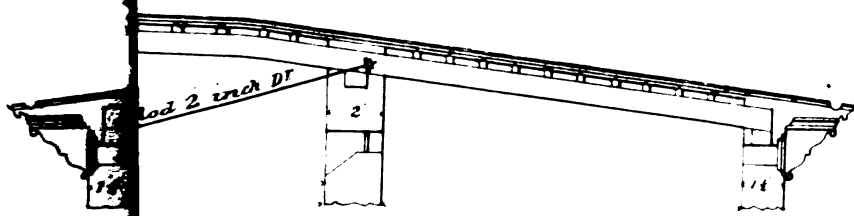
—  
udin  
7174

—  
/

—  
r ]

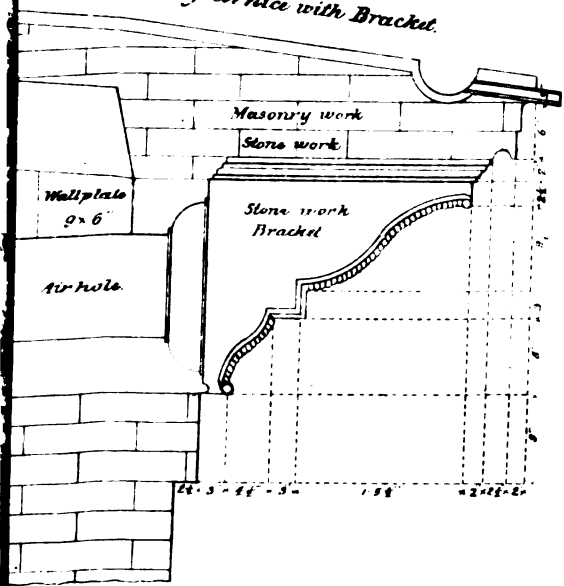
—  
22

ading Engineer.  
gineer,



Rooms

arged Section of Cornice with Bracket.





The floors of verandahs round the Record Rooms, are terraced, same as the verandah roof.

The Record Keeper's room, which is above the Deputy Commissioner's Court Room, has a boarded floor same as the Record Rooms, with this difference that the floors of the latter rest on good large beams, while those of the former are supported on strong trusses of deodar wood with iron tie-rods.

The doors are of sound deodar wood, 2 inches thick, (with joints properly fitted), hung on English hinges, and fitted with English bolts.

A masonry staircase in one of the rooms at the back of the Deputy Commissioner's Court Room, gives access to the upper floor.

The main outer cornice is of red sandstone properly cut and supported on corbels of the same description.

All the Court Rooms are fitted with proper railings and seats for the Judges, &c., and the Currency and District Treasure Rooms have each an iron vault, 4 × 4 × 4 feet, sufficient to contain 5 lakhs of treasure.

The Record Rooms are fitted with racks for the records, along the walls, with a double row of racks in the middle.

A space of 18 feet all round the building is metalled with bricks, with a good slope outwards, so as to lead the drainage away from the building.

The accompanying plan shows the style of the building, and the abstract gives the quantities of different descriptions of work, together with the *actual working rates*.

---

Area covered by the Building, 82,564.5 superficial feet. Cost Rs. 95,420-8-5. Rate per superficial foot, Rs. 2-15-0.

---

ABSTRACT.

c. ft.		RS.	A.	P.
30,080.5	Foundation of small bricks, at Rs. 14-15-11½ per 100, .	4,511	3	7
6,9437	Pucka plinth, outer walls, of small bricks, faced with large bricks, at Rs. 22-5-6 per 100, . . . . .	1,551	6	1
1,648-125	Pucka steps of large bricks, at Rs. 35 per 100, . . . . .	576	0	0
8,488	Pucka plinth inner walls, of small bricks, at Rs. 17-3-9 per 100, . . . . .	1,462	12	5
1,14,882.26	Dressed pucka superstructure of outer walls, at Rs. 30 per 100, . . . . .	34,465	0	6
	Carried over, . . . . .	42,566	6	7

		RS.	A.	P.
		Brought forward, . . .	42,566	6 7
r. ft.				
1,990	Outer brick cornice of lower floor, at Rs. 0-12-0 a foot, . . .	1,492	0	0
1,660	Stone cornice of outer walls of main building, at Rs. 0-12-0 a foot, . . . . .	1,245	0	0
No.				
100	Stone corbels, at Rs. 8 each, . . . . .	800	0	0
r. ft.				
143	Cutting and dressing of mouldings, at Rs. 3-14-0 per foot, . . .	554	0	0
2,354	Inner cornice, at Rs. 0-6-0 per foot, . . . . .	882	11	7
s. ft.				
17,332	Flat pukka roof, 12 to 14 feet span, at Rs. 42 per 100, . . .	7,267	8	8
6,312	Floor over rooms, 12 feet span, at Rs. 40 per 100, . . .	2,525	0	0
6,120	Trussed roof, 20 feet span, at Rs. 56-15-10 per 100, . . .	3,487	6	0
6,580	Floor over rooms, from 20 to 24 feet span, at Rs. 90-2-6 per 100, . . . . .	5,932	6	0
5,310	Trussed roof, 30 feet span, at Rs. 88-10-2 per 100, . . .	4,706	10	2
1,468	" 24 " 74-9-10 " . . . . .	1,095	6	0
4,374	Doors, glazed and pannelled, at Rs. 1-0-4 a foot, . . .	4,474	0	0
466-52	Glazed fan lights, at Rs. 1-2-0 per foot, . . . . .	525	0	0
26,400	Tiled floor, at Rs. 14-15-4 per 100, . . . . .	3,949	6	10
71,592	Pukka plaster inner, including mouldings, at Rs. 3-6-8 per 100, . . . . .	2,448	0	0
69,992	Inner white-washing, at Rs. 0-4-0 per 100, . . . . .	174	0	0
r. ft.				
9,700	Mouldings round arches and doorways, at Rs. 0-3-0 per foot, . . . . .	1,818	0	0
1,131	Iron railings, in upper story, at Rs. 1-8-0 per foot, . . .	1,696	0	0
c. ft.				
9,776	Concrete below foundations, at Rs. 10-0-6 per 100, . . .	980	14	0
11	Fire places, (9 double and 2 single) including mouldings and extra cost of making wood work of roof, <i>fireproof</i> , at Rs. 50 each, . . . . .	550	0	0
	Clearing site and dismantling three barracks, . . . . .	1,510	0	0
	Clearing rubbish after completion of work, and dressing ground outside, . . . . .	200	0	0
Total Rs., . . . . .		90,889	11	5
Deduct value of old materials, . . . . .		8,000	0	0
		82,889	11	5
Add contingencies, at Rs. 5 per cent., . . . . .		4,530	13	0
Grand Total Rupees, (cash expenditure,) . . . . .		87,420	8	5

K. L.

## No. CV.

---

IMPURITIES OF SOILS AND WATERS.

---

*Translation by A. NIELLY, Esq., Assist. Engineer, P. W. D., of an article written by M. C. BULOZ, editor of the "Revue des deux Mondes," and published in the Number dated 1st August, 1871.*

---

*Note by Translator.*—This article does not treat of subjects which belong, strictly speaking, to engineering science; but it treats of the causes of fevers and epidemics in districts and towns, and shows indirectly that the remedy to those scourges lies in the hands of Engineers. I have thought, therefore, that it might be very useful to attract the attention of the Engineering Corps to the causes of maladies which have become so general in India. The members of the profession have more occasion than any body else to study the soils, and sub-soils, and can therefore suggest the remedies which would purge them of impurities and restore health to districts and towns decimated by fevers.

In this article is also found the description of the formation in France of a curious kind of tufa or kunkur which, except that it does not seem to contain lime, has some points of resemblance with our kunkura. This description may throw a great light on the formation of many of our sub-soil deposits, and is therefore worth publishing.

THE IMPURITIES OF THE SOILS AND OF THE WATERS.

A few months ago, the mail of South America brought us the news that the inhabitants of the town of Buenos Ayres were decimated by yellow fever. It is known now that the terrible epidemic which so cruelly contradicted the general belief in the salubrity of that place, was not yellow fever, but a very peculiar illness caused by effluvia from the soil. At Buenos Ayres they have no sewers; the soil is directly permeated by all the residue of organic and social life. This secular neglect has taken its revenge; they have sown filth, and they reap fever.

This is an occasion for recalling very important researches which have contributed in throwing light on the rôle which the sub-soil plays in the production of epidemic and endemic maladies. There is a district in France where it has been possible to study that influence in a very complete manner, and in conditions which have been considerably modified with the time; that country is called the "Landes de Gascogne" (the brambles of Gascony). The sand of this district resembles that of the sea shore; it is white, mixed with some black grains in which are found the peroxide of iron and the oxide of manganese. Rain water has washed them during centuries, so that they no more contain any thing readily soluble; but at the mean depth of 3 feet below the surface is found, interposed in the thickness of that sand, a stony layer, compact and impervious, which acts as a receptacle of organic matters. That species of tufa, of a dark brownish red color, called "alios," is to be met with only in the grounds covered with brambles, and it does not exist either in the swamps, or on the sand hills—even those which are covered with shrubs and sheltered by secular forests. The pickaxe only can break the 'alios,' but it is of variable hardness; in some places it softens when exposed to the weather, in other places it is hard enough to be used as a building stone. As to the chemical composition of that mineral, it is sand agglutinated by a red cement of an organic nature, which receives its color from a weak proportion of hydrated oxide of iron.

M. Fauré of Bordeaux, who has thoroughly studied the tufa of the Landes, has found since 1847 that the matter to which the cohesion of the siliceous molecules is due, is a vegetable sediment deposited by the water which penetrates the soil. That matter by solidifying forms an impervious layer, which keeps rain water at a small depth below the surface. This rain water stagnates, loads itself with the products of decomposed vegetation, and go to poison the wells from which the population of that district draw water for domestic use. The waters of the sub-soil examined by M. Fauré were too rich in mineral matters, and also contained organic matters in a proportion truly dreadful. It is admitted that water is not insalubrious, and may be declared drinkable, when it contains by litre, about 60 centigrammes of mineral matters, and 1 centigramme only of organic matters. The analyses of M. Fauré have revealed the presence of from 10 to 20 per cent of organic substances in some of the subterraneous waters of the Landes, whereas mineral matters existed in the

proportion of from 20 to 80 centigrammes per litre. Here are three analyses (3, 4, 5,) which can be compared to the analysis (1) of a very pure water, that of the river Garonne at Castets, and to the analysis (2) of the water of a well at Reims, which is known as very insalubrious.

		In one Litre	
		Mineral matters.	Organic matters.
(1).	Garonne at Castets, .. ..	0 gr. '145	0 gr. '008
(2).	Reims, well of Hotel Dieu, ..	0 " '420	0 " '142
Sub-soil of the Landes district.	(3). Le Parpt, .. ..	0 " '890	0 " '186
	(4). Le Buch, .. ..	0 " '574	0 " '217
	(5). St. Vivien, .. ..	0 " '821	0 " '022

The color of the waters of the Landes is yellowish brown, more or less dark, sometimes slightly greenish; they have a swampy smell and sapidity which partly disappear by ebullition after the deposit of a frothy sediment which has the character of vegetable albumen. This boiled water could be kept in bottle for one month or more without alteration, whereas four or five days are sufficient to putrefy the water which has not been boiled. This water may be considered as the principal cause of the paludal fevers which for centuries have been endemic in that district of France.

The state of things is now very much changed since the Landes have been transformed into vast plantations of the maritime pine. This is how M. Faye, looking back on an interval of thirty years, describes his impressions in a note which he has read at the Academy of Sciences during last spring. "These vast plains which," he says, "I have seen deserted, and the heath of which was the miserable food of a few herds of sheep, watched by shepherds on stilts, are covered now with rich plantations of maritime pine; but what has not changed is the impervious layer of alios. . . . The influence of this invisible layer on the health of the inhabitants of the Landes has been great; by keeping the products of vegetable decompositions near the surface of a soil almost without slope, the alios has made intermittent fevers permanent in this poor region, whose inhabitants principally fed themselves with the almost antediluvian food, bread without yeast. Now fevers have disappeared, they speak no more of the sinister and mysterious 'Pollagre,' and the alios acts only on the roots of the pines, which instead of screwing themselves in the soil as they generally do, have now to follow the hard crust of the alios. How can this result be explained? By looking back on the causes which gave birth to the tufa



of the Landes." M. Fayè has been able to study them thoroughly during the levelling works of which he was in charge in 1837, and which necessitated so many soundings.

The layer of 'alios' is met with at the depth of about three feet, it varies in thickness, which is generally small and covers an indefinite layer of sand identical to that of the surface. When during the summer a hole is made in the soil as far as the 'alios,' there appears a small quantity of yellow water scarcely drinkable; but if the hole goes beyond the tufa, an abundance of limpid water is found immediately. They succeed now in preserving the limpidity of that water by cementing the sides of the wells as far as the 'alios,' so as to prevent any lateral infiltration. There exists therefore during the summer a subterranean layer of water which stands at the level of the stony concretion. During the winter and at the beginning of the spring, the almost level soil of the Landes is like a sponge impregnated with rain water. Under the influence of the sun, that water evaporates during the spring and the summer to a depth of three to six feet, which agrees with the general level of the tanks and swamps of the country. The 'alios,' therefore, seems to mark the "etiage" or lowest point of the ebb of the sub-soil waters; it somewhat materialises this subterranean ebb. The roots of the vegetables which grow on the Landes cannot remain in stagnant water during one half of the year without being partially decomposed, the products of which decomposition are carried downwards by the ebbing waters at the approach of the summer. During the periodical stagnation of the 'etiage,' the organic sediment are deposited, and they agglutinate the grains of sand; these deposits renewed during centuries formed the layer of tufa the existence of which appeared so difficult to explain. In the swamps the 'alios' cannot be formed, because the waters do not retire under the soil; it is not to be found also in the sand hills covered with trees, because rain water does not remain there, but flows immediately either towards the sea or towards the swamps of the interior. On those sand hills, the long roots of the pine go down to a great depth without meeting any obstacle. The 'alios' is formed only in the plains where the winter rains produce a subterranean sheet of water forced to ebb vertically, and to remain periodically stagnant at a fixed level. The presence of ferruginous matter in the aliotic cement can be explained by the action which, according to M. Spindler, the putrified plants exercise on the oxides of iron. This chemist

has proved that under the influence of decomposed roots, the peroxide of iron modifies itself and becomes soluble by the acids which are made free; the iron of the black grains, rendered soluble, is carried away by the waters and such is the origin of the ochreous coloration of the 'alios.' M. Daubrée has explained by the same chemical action of the vegetals, the formation of the marshy iron in the lakes of Sweden. The waters having become ferruginous by the action of the plants run into the lakes, and by slow degrees deposit a rich mineral on the bottom. This marshy iron is also met with in some of the swamps of the Landes; for instance in those of Mimizan, which in times past have been worked for iron.

The fatal influence of the impervious layer of 'alios' has been now neutralised by very numerous trenches of small depths and widths which favor the drainage of the waters. The heath and the herbs which used to rot on the place where they grew have been driven away by the maritime pines, the roots of which little capable of alteration produce no more putrified deposits. With the products of the vegetal fermentation the fevers which weakened the races of this country have disappeared. Drainage has been the best and the surest of remedies.

M. Faye has drawn from these facts a generalization which appears altogether justified by experience. The sub-soil must play the principal rôle in the development of certain maladies. "In every place," says M. Faye, "where there exist at a depth of from two to three feet, an impervious sub-soil, contaminated by vegetal rotteness, intermittent fevers are to be met with; and typhoid fevers, when it is contaminated by animal putrefaction. This last point has been established in my mind by a long personal experience." Every time that when visiting a school, M. Faye heard that mucous or typhoidal illness came back periodically, he found immediately, by studying the soil, that there existed an infected superior layer reating on an impervious sub-soil; and reciprocally every time he found such a sub-soil with superior layers contaminated by cess-pools or by sewage cisterns not water-tight, he found also that the epidemic came back periodically.

The relation of cause to effect which exists between certain conditions of the soil and the development of fevers of various natures seems therefore to be established in an indisputable manner by the above remarks. The remedy is simple enough, it consists in preventing as much as possible any fermentations in the soil, and to insure the running off of the waters

by drainage operations. The rains then wash the soil, instead of impregnating it with dangerous germs.

What has been said is further confirmed by very curious observations which from a certain number of years have been made at Munich. This town, although situated at more than 500 metres above the level of the sea, in a country looked upon as salubrious, is frequently visited by terrific epidemics of typhus, the cause of which looked mysterious. For a long time the medical men have made vain efforts to discover some connexion between the illness and the atmospheric agents which might exercise some action on the human body. The barometer, the thermometer, the hydrometer, the weather-cock were interrogated, but none of these instruments could reveal the cause of the strange oscillations of the scourge, which came back periodically to decimate the population. Then the wells were suspected. To eliminate their influence, from 1860 the town was provided with spring water of an excellent quality; but the typhus, as if to show their impotency to men, came back on the same year with greater intensity; and the quarters of the town provided with spring water were as ill-treated as those in which well water was still drunk. It was, therefore, evident that the causes of the returns of typhus could not be looked for either in the atmospheric agents, or in the drinkable water. The sub-soil remained. It is M. Pettenkofer who had the idea of connecting the typhoid phenomenon with the influence of the sub-soil, and in particular with the tides of subterranean waters.

This chemist has followed during more than 10 years the movements of water in the soil of Munich and some other localities, and has proved that the lowest 'etiage,' or level of the ebb of the subterranean lake shows considerable variations from one year to another, and even sometimes in the space of a few weeks, the difference of levels being sometimes as much as several metres. The comparison of these variations with those of the typhoid epidemics, written side by side, revealed the concordant march of the two phenomena. Every time that the level of the subterranean waters has fallen perceptibly, the typhus has shown a remarkable increase, and it is seen to diminish as soon as the waters rise. In his journal of Biology, M. Pettenkofer has published in 1868, a chart which shows the curves of mortality caused by typhus at Munich, those of rain water, and those of the mean 'etiage' of subterranean waters for every month during 12 years, from 1856 to 1867. By glancing only at these curves it is easy

to find immediately a great relation between the oscillations of the subterranean lake and those of the epidemics. If you look for the very lowest ebb, which was observed in 1857, it is to be found by the side of the most terrible epidemic which took place in the winter of 1857-58. The epidemic next in intensity was that of 1865-66; it corresponds to the second minimum of the 'etiage.' This coincidence of the relative minima of the 'etiage' with the relative maxima of the mortality exist also for the winter of 1863-64, for 1862, and for 1861. If we look for the inverse proof and find in what year the highest 'etiage' took place, it is met with in 1867, which is the year when typhus acted with the lowest intensity since 1857, the number of cases reducing itself to 96. The striking parallelism of the curves almost compels us to suppose that there exist between the 'etiage' of the subterranean waters, and the development of typhus a relation of cause to effect.

We can also inquire in what way the influence of the water with which the sub-soil is impregnated is exercised. It is proved that the maladies attributed to the action of the miasms develop themselves more easily in the places the soil of which is formed by light and porous alluvium. These grounds absorb constantly some organic detritus capable of decomposition under the influence of heat and dampness. Experience teaches us also that swampy localities, that plains exposed to frequent inundations and covered with a rich vegetation, favor eminently the production of miasms, whereas regions where the soil is formed by a compact rock generally enjoy an almost complete immunity. In connecting together all those well known facts, we come at once to the conclusion that the essential condition for the development of the miasms is the presence of putrescible organic matters which are alternately exposed to the influence of air and water. This condition is fulfilled by a porous soil where water presents great variations of level near the surface. By rising quickly, this water produces a sort of subterranean inundation, in receding it leaves behind a marsh full of fermentescible substances, which air, by penetrating in the ground, surrounds in proportion as the water leaves them. This marsh is not influenced by the wind which might scatter away the emanations, it is a receptacle of decomposition, the products of which accumulate at the surface of the soil. The surfaces of contact which decomposed matters present alternately to air and water are indefinitely multiplied by the interstices between the pebbles and grains of sand which compose a

light ground. Suppose, for instance, that the ground is formed of globules of a mean diameter of two millimetres, by going down to the depth of one metre, the total surface developed would exceed three thousand times the free surface of the soil. This shows sufficiently the pernicious influence of the dissemination of organic matters in a porous soil. It is again possible that the temperature of the sub-soil has also some relation with the apparition of the epidemics. At Munich, the typhus appears generally towards the end, or at the beginning, of the year (in December, January, February); this is the time when the temperature attains its maximum,  $11^{\circ}$  at the depth of 7 or 8 metres, as it takes six months to penetrate as far in the soil.

Several authors think that cholera depends equally on tellural influences. They bring forward the argument that this epidemic does not exercise its devastation in localities the soil of which is rocky and compact; that it decimates the population of villages built in a hollow between two heights on a soil formed with detritus, whereas it spares neighbouring hamlets built on rocks: but we must not allow ourselves to be carried away by the attraction of simple theories which often persuade us to accept bold analogies for facts. In the case in which the influence of subterranean waters is well proved, we conceive the possibility of regulating the tides by artificial means, as water-courses are regulated by sluices, and of preventing too sudden variations in the interest of public health.

The next cause of these tellural influences must be undoubtedly looked for in the microscopic beings, infusoriæ and fungi, which develop themselves during the decay of dead matters. It is through this cause that these phenomena connect themselves with those due to the miasms of swamps. These last have been greatly studied lately; we shall bring forward, among the works which treat of this subject, only the very interesting paper by Doctor Balestra, which was communicated to the Academy of Sciences about a year ago. In examining with a microscope the waters of the Pontine swamps (near Rome) particularly by those of Maccarebbe and Ostia, the Italian physiologist found them full of infusoriæ of all types, and of granulated microphytes, among which the most remarkable was a small alga, the form of which somewhat resembles the *Cactus peruvianus*. This plant is found in the waters in proportion to their degree of putrefaction, together with a great quantity of transparent spores of a greenish yellow, so small that a thousand of them placed on one line

would scarcely make one millimetre, and which are accompanied by sporanges, (vesicles,) about twenty times bigger. The small alga floats on the surface of the water where it produces an appearance like oil. It develops itself rapidly in water laden with vegetal detritus and exposed to the sun; but if you pour on it a few drops of arsenious acid, or sulphite of sodium, or better still, sulphate of quinine, you see in the microscope the infusoriæ dying, and the spores fading and falling. M. Balestra has found, besides, that these spores are disseminated in the air of the swamps; he found them in quantity in the dew which deposits itself on a cold glass. The atmosphere of Rome and of the suburbs contain them in variable proportions according to the season; they are in abundance towards the end of August, and especially in the day which follows the end of the rains. Everything concurs to prove that these spores give birth to the small alga already mentioned, and that it represents the miasmatic principle of the Pontine swamps. The small alga becomes developed only under the influence of a moderate dampness, of a little rain, of a night dew or a fog. This explains the increase of intermittent fevers at Rome in August and September. The evident action that the salts of quinine and other febrifuges exercise on the spores explain also the effect of those specifics on the human organism. In presence of facts of this nature, it would be difficult to deny that these miasms have in them something material, tangible, even then alive; it is the germ which the atmosphere carries about and which weakens the organism at the expense of which it develops itself.

It is difficult to say how the deleterious action of water when polluted by animal and vegetal matters is exercised when such water is absorbed; but that this action is proved, is undisputable. Many reports have been made by competent commissions on the noxious effects of the pollution of rivers which receive the sewage of manufactories and of towns. It is certain that below all the large towns, the water is horribly insalubrious. It has been believed during a long time that the organic matters mixed with the waters of a river oxidised themselves by the action of air, and that in consequence the river becomes completely pure again after a certain length of its course. It is not so; the recent experiments of an English commission, the reporter of which was a celebrated chemist, Mr. Frankland, has demonstrated that there is not in all the United Kingdom a river long enough to render possible the destruction of organic matters by the oxygen of atmosphere. The course of a river can only exercise a material

influence by the deposit of a large quantity of organic and mineral impurities suspended in the water, and which, carried by their weight, sink to the bottom. It is that external clarification which made us believe in the rapid improvement of running waters; but the dissolved matter is eliminated with very great difficulty, and what is deposited gives to the river a muddy bed. The Seine receives annually at Paris 260,000 cubic metres of dirty water, and every year this muddy flood encumbers the river with 120,000 tons of solid deposits, without speaking of the chemical pollution of the water. Instead of spoiling the rivers by the dejections of the towns, it would be better to utilise the sewage for the irrigation of the plains, as agriculture loses what the public health could spare. Fortunately this question begins to attract the serious attention of hygienists. The inhabitant of the towns pays very dear for the advantages he enjoys, if the ground that he treads upon and the water which he drinks poisons him slowly; but it is the deserved punishment of our carelessness. We learn at our expense that to bury is not to annihilate, and to drown is not to destroy. We believe ourselves cleared at a small outlay, of that filth which incommodes us, but it comes back, implacable ghost, under the hideous features of epidemics.

A. N.

---

---

**No. CVI.**

---

**MICHELE'S CEMENT TESTING MACHINE.**

---

*Communicated by J. MACDONALD, Esq.*

---

In connection with the subject of Cement Manufacture in India, which is now attracting the attention of many Engineers in this country, the accompanying drawings and descriptions of a good form of testing machine may be studied with interest.

*Patentee's description.*—"The block to be tested is placed in the jaws prepared to receive it; the hand wheel is then turned, which raises the weighted lever, by exerting a pull on its short end through the medium of the cement block. When the leverage is so increased as to exert a force too great for the cement to sustain, it breaks, and the lever falls, leaving the index-pointer at the spot to which it had been raised. The arc along which the pointer moves is graduated to show the number of pounds of tensile strain applied. A suitable arrangement, when the cement block breaks, prevents the lever from falling more than half an inch.

"As the force is thus gradually applied to the block of cement, it is impossible that its breaking point can be influenced by any jerk or uneven strain.

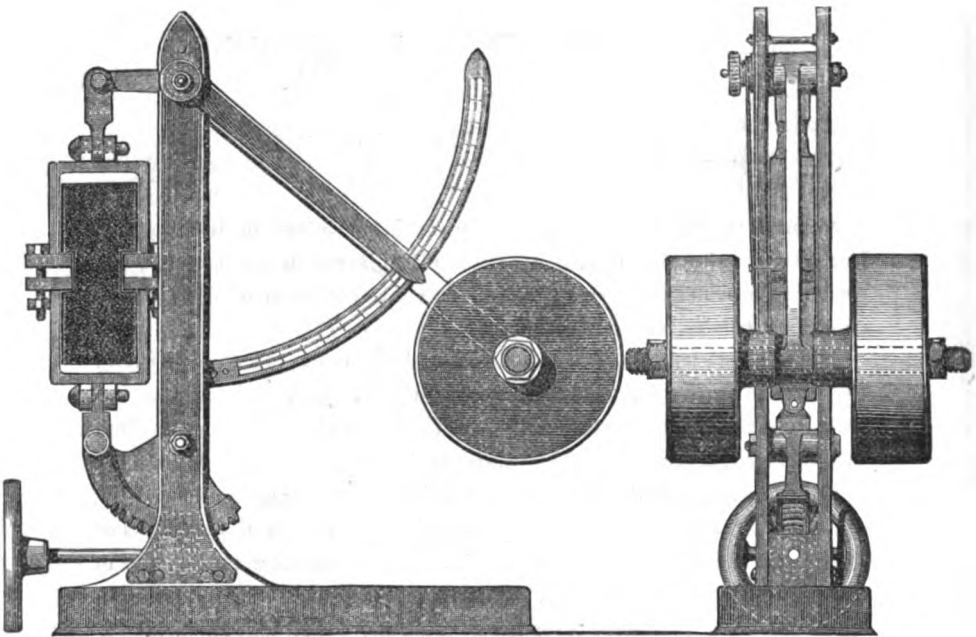
"Price of a Machine to exert a tensile strain not exceeding 1,000 lbs., £24."

*Notice in the "Engineer," dated 23rd December, 1870.*

"In the accompanying engraving we illustrate an improved cement testing machine which appears to possess many advantages over those ordinarily used. The general idea of its construction originated with



M. Michele, but all the details were worked out by Mr. Carrington. Its action will be understood in a moment. By turning the hand-wheel the lower clip, holding the cement to be tested, is drawn down, and thus a tensile strain is exerted on the block or brick, which increases as the weights are raised, until a fracture takes place, when the weights fall, leaving the pointer indicating on the segment the exact maximum strain withstood. There are small bolts provided on the clips, which are so adjusted that the



clips can only part slightly when the cement breaks, and the weights thus drop only to a very limited extent. The use of cement, especially Portland, is rapidly becoming more general, and the want of a good testing machine is felt. To meet this want the machine we are describing has been designed, and what is claimed for it is that it will apply a regularly increasing strain without any jerk, that it is of a convenient size, and that it can be purchased at a moderate price. One has lately been obtained for their London tests by Messrs. Francis and Co., the well-known cement manufactures, and it may be seen at work at their office, Vauxhall Bridge, any day. It may be taken as a proof of the satisfaction it has given, that

Messrs. Francis have ordered another for their works, and their cement will be tested with no other machines."

*Notice in "Engineering," dated 23rd December, 1870.*

"We illustrate, above, a very neat arrangement of cement testing machine, designed by M. V. de Michele, of Weybridge, and lately patented by him. The action of the machine will be readily understood on reference to the illustration. It will be seen from the latter, that the sample of cement to be tested is held by two clips, the lower one of which is coupled to one corner of a toothed segment, into which a worm gears, as shown; while the upper clip is attached to the short arm of a bent lever, of which the longer arm carries a counterweight. This longer arm also has projecting from it a pin, which, as the arm moves outwards, causes it to carry with it a light pointer, which traverses a divided arc. The sample to be tested having been fixed in the clips, the hand wheel, with which the worm is provided, is turned, thus applying through the toothed segment a tensile strain to the sample, the amount of this strain being measured by the extent to which the longer arm of the bent lever is moved outwards. When the sample breaks, the longer arm of the bent lever of course falls, but it leaves behind it the pointer, which indicates on the scale the amount of strain at the moment of fracture. We should add that the two clips by which the cement is held, are connected by a pair of small bolts, as shown, these bolts being adjusted, so that the weighted arm of the bent lever can fall through but a small distance when the sample breaks.

"The machine we have described is altogether a very simple and convenient one, and we expect to see it largely employed amongst cement manufacturers and cement users. We may add that Messrs. Francis and Co., the cement manufacturers, have got one of these machines in use at their office, near Vauxhall Bridge, and we understand that they are about to put up another. In conclusion, M. de Michele desires us to state that although the idea of applying a weighted bent lever to a testing machine was his own, yet that the credit of working out the details of the machine in its present form is due to his friend Mr. W. Carrington."

J. M.

## No. CVII.

---

### WELL FOUNDATIONS AND WELL SINKING.

---

BY EDWARD BYRNE, Esq., *M. Inst. C.E., Exec. Engineer, P. W. D.*

---

WHEN on the Oude and Rohilcund Railway, and about the time that serious disasters occurred at certain well known bridges in India, I had to prepare stability calculations of the principal works on that line.

They were criticised, in a kind spirit, by others,\* who probably from a wish to provoke discussion, expressed the belief, 'that whilst the overturning forces had been over-estimated, sufficient consideration had not been given to the resisting power.'

Having bestowed some thought on the subject, and written out the conclusions at which I arrived, my observations were issued for limited circulation.

Strange as it may appear, nothing on the subject, so far as I could discover, had ever before been published; and to the discouraging feeling of having to act, in a matter of so much importance, without a precedent, may be attributed my unwillingness to let these papers appear in the Roorkee Series, until I could send them in a more complete form.

From the nature of the subject, much of the calculations had to be based on very uncertain data. Besides, though they fully answered the purpose for which they had been intended, I was desirous of substituting, as far as possible, strictly mathematical calculations for what, in part, had been dealt with approximately.

\* Especially by General Beadle, R.E., Agent of the Oude and Rohilcund Railway Company; discussions with whom gave rise to the observations which accompany the calculations.

With a view the better to make my efforts useful to others, I purposed consulting some one, whose special knowledge, as a professed mathematician, would enable him to assist me in the solution of problems, like that of friction, to which I, myself, might feel unequal. Moreover, in order to supplement the treatise with such practical data as might guide the Engineer in framing his estimates, as well as in selecting machinery, I tried, but unsuccessfully, to collect reliable information from various sources, regarding the cost of sinking in different strata, and at specified depths; with statements descriptive of the implements employed, and the way in which difficulties, if any, had been overcome.

By Captain Allan Cunningham, into whose hands a copy of my papers fell, I have, in the mathematical bearing of the question, been ably anticipated. But, as something more has still to be done, my original pamphlet, in abridged form, is now submitted, in order to ventilate the subject; and with the hope of inducing others to give their contributions.

---

1. In all cases in which there is reason to fear that scouring action may take place to within a short distance of foundation level, overturning leverage should be measured from the base. Leading, however, as this does, to the erroneous conclusion '*that increased depth of sinking is attended with diminished stability,*' the system must be wrong in principle, and calculated, at times, to exaggerate the forces which tend to overthrow.

2. A well should not be left in a position to overturn, but be sunk to such a depth that failure can only occur in the event of fracture.

3. The depth to which a well must be sunk in order that the hold at bottom may necessitate fracture, has been approximately determined first, by assuming, as the level of scour, that which (the Ramgunga and Gurrah being excepted) appeared to be the lowest possible consistent with experience of past floods, and a knowledge of the river bed; then, according to the nature, more or less unyielding of the strata passed through, considering the breaking off to occur at a distance, below this, of from 3 to 10 feet; and, afterwards, adding such further depth as might correspond to a mass of earth that should, in case of displacement by overthrow, yield a resisting power equal to that which might be afforded by the tenacity of mortar in the plane of fracture.

4. The breaking off point has been assumed to lie below the level of

greatest scour, because, not until going some feet further down, would the river bed be sufficiently indurated to act as a fulcrum across which the well might break; but, as the resistance below, from a mass of vast horizontal extent, would, no doubt, exceed that derived from multiplying leverage into the weight of earth displaced, the depth of sinking required, in order that the holding or grip at bottom should occasion fracture, would probably be less than that assumed in the calculated tables.

5. Overturning leverage has been measured from the level thus assigned, to the breaking off point, because, in the event of overthrow, it would be the turning point: fracture might, however, occur higher up.

6. The heaving of a well, in part, with sand, is clearly inadmissible where, by reason of contracted base, and limited cross section of masonry, stability and strength are dependent on deep undersinking, and tenacity of mortar—a statement that applies more particularly to single than to double, or a system of wells, of which the stability, due to extended base, and weight, may, alone, be amply sufficient.

7. The amount of injury which it is possible for a floating mass to inflict on a body at rest, depends on the nature, and relative weights of both; on the velocity, and direction of the blow; the height, above base, at which it is given; and on the power of the striking body to preserve its form after collision. If easily destroyed, it may, itself, be injured, while the pier, on which it is shattered to pieces, may, comparatively speaking, escape unhurt; and even when able to bear the shock, if, instead of coming, end foremost, down the stream, and bearing directly on the middle of a pier, it should swerve aside, and then glance off, the effect produced might be very trifling. However, as this is quite a matter of chance, it is evidently best to prepare for the more serious contingency, and calculate the effect of impact at a maximum.

8. Rough treatment to brickwork should, as much as possible, be avoided, for disturbance, of any kind, is prejudicial to the setting of mortar; and its proper adherence to work which it is intended to keep together. Yet, contrary to what should be the practice, sinking, as a rule, is commenced before the mortar has time to set.

9. The resistance due to tenacity of mortar is not a certain force; because, so much depends on its quality; on the time it may have been in the work; and on the conditions under which setting has been allowed to progress. Hence, tenacity has been presumed to apply to one-half only

OVERTURNING POWERS.

5 feet.

Ramgunga

Roofing

With Flooring

Leverage of Overturning Powers.

Leverage of Overturning Powers

level

level

Flood

level

Low water

level

Line of scow and Urd of plane of fracture

FLOORING

Wind v. Girder

Wind v. Pier

depth of snow?

plane of fracture?

S a n d

S a n d

S a n d

Girder  
Wells  
Pier  
Cap

Leverage of  
Resisting Powers.

Girder  
Pier  
Wells

.8

Leverage of  
Resisting Power





of the plane of fracture, though, if the work be uniformly good, it should be calculated for the whole plane; or credit given for resistance to compression, in that part which is not in tension.

10. Vertical tie-rods are employed to establish connection between the curbs, and the masonry; but the advantage of carrying them higher up than is necessary for that purpose, is questioned by some engineers, who are of opinion that they acquire a vibratory motion, in the operation of sinking, which tends to loosen the masonry. It may, however, be presumed that good cement would be employed, if less expensive, as the advantage of using quick setting mortars, in well masonry, is beyond all doubt.

11. The tenacity of mortar, calculated at 20, 50 and 300 lbs., may, as a high figure, be taken at 50 lbs., per square inch. That of 300 lbs., attainable by the use of certain cements, is not a thing of ordinary practice; and if a floating mass, carried down by unexpected floods, should bear upon new, and hurriedly constructed brickwork, the shock received may quickly prove that the mortar had not attained a tenacity of even 10 lbs. per square inch.

12. The oscillating manner in which wells sometimes go down, is more or less attended with risk; for, if heeling over be excessive, and, when the mortar is still fresh, force be employed to regain position, fracture may ensue.

13. An injury sustained high up, which may be readily seen, and as easily repaired, is of little consequence; but, if low down, below the range of sight, remedy may be difficult, if not altogether impossible.

14. Steady sinking, in constantly shifting sand, may be accompanied by difficulties that test, to the utmost, an Engineer's skill. The habit, however, of relying too much on mechanical contrivances, as a means of righting a well, should be avoided, lest it be accountable for injuries like that described; and which ordinary precaution might alone prevent.

15. Past experience has shown that the Ramgunga river bed, if unprotected, may, wherever piers obstruct, be scoured out to a depth of 50 or more feet below low-water-level; and though, at any one time, this action may be of limited extent, yet, from the frequent shifting of the main water course, the concentrated force of a flood may, in different years, pass through as many different channels, and act, one after another, against all the cylinders.

16. Notwithstanding the deep scour in some places, the river bed is so





of the plane of fracture, though, if the work be uniformly good, it should be calculated for the whole plane; or credit given for resistance to compression, in that part which is not in tension.

10. Vertical tie-rods are employed to establish connection between the curbs, and the masonry; but the advantage of carrying them higher up than is necessary for that purpose, is questioned by some engineers, who are of opinion that they acquire a vibratory motion, in the operation of sinking, which tends to loosen the masonry. It may, however, be presumed that good cement would be employed, if less expensive, as the advantage of using quick setting mortars, in well masonry, is beyond all doubt.

11. The tenacity of mortar, calculated at 20, 50 and 300 lbs., may, as a high figure, be taken at 50 lbs., per square inch. That of 300 lbs., attainable by the use of certain cements, is not a thing of ordinary practice; and if a floating mass, carried down by unexpected floods, should bear upon new, and hurriedly constructed brickwork, the shock received may quickly prove that the mortar had not attained a tenacity of even 10 lbs. per square inch.

12. The oscillating manner in which wells sometimes go down, is more or less attended with risk; for, if heeling over be excessive, and, when the mortar is still fresh, force be employed to regain position, fracture may ensue.

13. An injury sustained high up, which may be readily seen, and as easily repaired, is of little consequence; but, if low down, below the range of sight, remedy may be difficult, if not altogether impossible.

14. Steady sinking, in constantly shifting sand, may be accompanied by difficulties that test, to the utmost, an Engineer's skill. The habit, however, of relying too much on mechanical contrivances, as a means of righting a well, should be avoided, lest it be accountable for injuries like that described; and which ordinary precaution might alone prevent.

15. Past experience has shown that the Ramgunga river bed, if unprotected, may, wherever piers obstruct, be scoured out to a depth of 50 or more feet below low-water-level; and though, at any one time, this action may be of limited extent, yet, from the frequent shifting of the main water course, the concentrated force of a flood may, in different years, pass through as many different channels, and act, one after another, against all the cylinders.

16. Notwithstanding the deep scour in some places, the river bed is so

high in others, as to average, on the entire length of bridge, more than three feet above low-water-level.

17. A well constructed flooring, as much as possible below low-water-level, would conduce to the removal of those elevated sandy portions which, by their very obstruction, give rise to scour elsewhere. Its value, in this instance, would be as a guard against scour, a regulator of flow, and a something to diminish maximum velocity of current. However, in order to avoid the heavy expense, and probable difficulty of successfully dealing with flooring, the system of deep sinking, and throwing in block kunkur around the wells, as a defence against scour, is that which is being adopted.

18. Training the course of a river, where practicable at a moderate cost, for some distance above the site of a bridge, should be attended to, helping, as it would, to equalize flow, and lessen the maximum velocity of current.

19. Among the well sinking appliances that have been found to act expeditiously, may be mentioned the vertical dredger with buckets. But if expedition be regarded as paramount to all other considerations, it may be used in such a way as to cause oscillation: that is to say, if through an imprudent desire to sink more in a given time than is possible, consistently with the execution of good—reliable work, the buckets be allowed to excavate too deeply in one place, before being moved to another, the well is certain to get out of perpendicular. To counteract this defect, the apparatus is then, perhaps, shifted, and made to act, until the leaning-over takes an opposite direction. After many repetitions of some such process, which, reckless as it may appear, has, even on important works, been practiced, the well is at length dropped down to what is intended to be its final resting place, in less time, of course, than if the dredger had been more frequently shifted; but, in such a manner, as to render accuracy of position uncertain, and soundness of masonry very doubtful, if not absolutely out of the question.

20. When the difference between low water and highest flood is small, the level of girders relatively low, and the action of scour certain to be confined within shallow limits, single wells, *carefully sunk*, may be quite sufficient; but the adoption of single wells, for great depths, is manifestly wrong. Wells are built and sunk in short lengths; one length being out of sight before the building of that immediately over it is commenced. If precision and solidity of work be strictly attended to by all concerned, from the Executive Engineer down to the humblest well sinker, it is quite

within the bounds of possibility to build and sink high columns with approximate accuracy; but where the merit of well sinking is supposed to consist in passing through as many lineal feet of ground as possible, within a given time, they are likely to be not only very crooked, but terribly out of perpendicular—so much so, that were it possible to expose these structures to view, from the very bottom, their appearance would probably cause dismay; and make converts of those who had previously adhered to the single well system—forced, as they would be, to admit, that the weight of the piers, with girders on top, must help to overthrow the columns, in whatever direction they may be leaning; which could not, in fact, stand at all, in a heavy gale, but for the grip or hold of the ground below.

21. In the district through which the Oude and Rohilcund Railway passes, wind may never attain a greater pressure than 14 lbs. per square foot; but instances are spoken of in which that of 40 lbs., corresponding to a velocity of about 90 miles an hour, has been exceeded elsewhere.

22. The weight of brickwork, in water, has, for simplicity sake, been taken at 50 lbs. per cubic foot, instead of 49·6 lbs., the difference between 112 and 62·4 lbs.

23. On the supposition, however, that there is no connection between the bottom of a well, securely sealed up with concrete, and the water above, it has been urged that loss of weight, by immersion, *is not sustained*.

24. A statement of this nature, involving, as it does, a no less serious question than that of *doubling*, approximately, the calculated stability given in these tables, is too important to pass unnoticed.

25. Masonry maintains its full weight as long as it is effectually protected, at the bottom, against the action of water. Moreover, by reason of the same laws upon which loss of weight, by immersion, depends, it may gain weight if, while thus protected below, it be covered by water above; in as much as to the weight of brickwork, must be added that of the superincumbent water.

26. If sunk into, and resting upon, stiff clay, such a thing is quite possible; but it is easy to conceive how, *at any moment*, the conditions of such a very exceptional case may be completely altered. The broken vertical surface of the clay, burst through, is unfavorable to the formation of a water-tight joint. If, too, on account of some disturbing cause—of the possible, and very probable proximity of sand, gravel, or kunkur, water, in communication with that above, get beneath the masonry, the latter would

be urged upwards by a force equal to the difference between the pressure upwards and that downwards—by a force equal to the weight of a column of water having the same base, and the same height—that is, by a force which takes from it a weight equal to that of the volume of water displaced.

27. The pressure of a liquid against the vertical sides of an immersed body has nothing to do with diminishing its weight, as this depends entirely on the upward pressure against its lower surface; and though very convenient, for calculation, to consider the weight, per cubic foot of brickwork, below high flood level, as 62·4 lbs. less than that above, it would be more in rule—what, in result, would be the very same, to give all brickwork, with girders on top, credit for full weight; and then, to deduct, from this sum, the weight of the volume of water displaced.

28. If water from the bottom of a well should rise within, to a higher level than that without, it must come from a higher source—from one that imparts a greater upward pressure—that gives, in fact, a larger amount of support than the latter; and which, for that very reason, tends, still more, to diminish the weight of brickwork. After going through thick beds of clay and kunkur, springs were tapped in the Gumti, Burna, and Saie, which rose, within the wells, to a height of from two or three, to sixteen feet (at the Saie) above the level of the water outside.

29. Communication between water above the river bed, and that below a well, may take place close to its outer vertical surface, unless cut off by the interposition of stiff clay, when it could be effected only by means of a more circuitous channel. Communication, however, may be so imperfect—the passage of water may be so interrupted, that the pressure due to the entire column of water, measured from surface to base, cannot come into force. The manner in which springs burst up, from beneath a well, proves, however, that it sometimes does do so; and that it is advisable to calculate as if it always would.

30. Next, as sound masonry, resting on a rock foundation, with perfect contact, and no water between, loses nothing by immersion, it has been argued that the upper portion of a well—that above the plane of fracture, though in water, will maintain its full weight. To which it may be said that, in such a case, there may be no loss by immersion before fracture takes place; but, from the very moment that it does, there certainly would be.

31. If, as an experiment, when a perfectly cylindrical column, of a material specifically half the weight of water, has been sunk, to the very top, in sand, sandy clay, gravel, or other strata permeated by water, the surrounding material be held back, so that the water, from percolation, be allowed to fill the intervening space, then, friction from the outside—the *only thing that could have held it down*, being withdrawn, the well would ascend until half its length appear above the surface.

32. The earth from beneath a sinking well being removed, descent, depending on weight, is opposed by the supporting action of friction, as well as, if in a river bed, the upward pressure of water. The question arises, can friction also act as a holding down power, in opposition to the upward force of water? For, if so, upon the extent to which it neutralizes the latter, will the amount to be deducted from full weight depend. At all events, in the manner in which wells are sometimes suspended in kankur clay, or other hard material, through which they are being sunk, there is much to suggest, *that friction may act as a large counteracting force to that of buoyancy*—so large, that if, of the total height of masonry from foundation level to that of high flood, the greater part remain in such a bed, credit *might* be given for full weight, without practically deviating from truth. Scour, however, tends to destroy its very existence, so that if, at the time of high flood, the masonry, below the level of scour, be small in depth, and embedded in mere sand, friction, as an aid to stability, would be worthless.

33. It is when bearing in mind that scouring out, to foundation level, is to render stability dependent on weight and base, and that firmness, so frequently wanting in the latter, being absent, stability *cannot* exist, that the value of deep sinking may be best understood, admitting, as it does, of lateral support to steady a well, and make it, in a measure, almost independent of base.

34. The sudden bursting up of clay, at the bottom of a well, which, for a while, had served as an almost water-tight joint, to keep the work inside sufficiently dry, without the aid of pumping apparatus, is a thing of ordinary occurrence. Due to a change of soil, and the presence of water, it shows how unusual it is, in the river beds of India, to meet with clay, for any considerable depth, that is free from sand and kankur; and proves, if proof be wanting, that at any time, and at all depths, water may be found. If this had an outlet below, through which it could make a *down-*

ward escape as fast as it arrives, there would be no accumulation of water nothing to constitute a force, no upward pressure, and, consequently, *no diminution of weight*. But as this is manifestly not to be expected, it cannot be noticed in calculations of stability.

35. The pier, with its foundation, has *not* been supposed to stand on water, but in, and upon a water bearing stratum—to rest, as it were, on a series of points, like those presented by a bed of gravel, through which the water has freedom of passage.

36. The truth of these assertions being admitted, it appears that if, in the same river bed, solid rock, clay traversed by water-bearing strata, and semi-fluid sand be found, the retention of full weight would be, in one case, possible; in another, improbable; and, in a third, impossible. And as it is necessary to calculate for the two latter, the former being very exceptional, only 50 lbs. per cubic foot, have been allowed as the weight of brickwork below high flood level.

37. In the following calculations\* of stability, all the forces, tending to overthrow, *taken at a maximum*, have been supposed to act, simultaneously, against the *minimum* resisting power. Any amount of the latter, due to friction at the bottom, being deemed too insignificant, and the masonry, above the plane of fracture, possibly so much injured by careless sinking, as to render full weight out of the question; and to suggest the advisability of considering all undecided resisting power as a mere set off against some possibly unforeseen disturbing element.

\* The calculations are given in abstract only, the details of one case—that of the Cawnpore Ganges Bridge, being considered sufficient.

**CLAYTON GANGES BRIDGE.**

One 18 feet, and one 10 feet well, connected at the top, with Pier to carry the Girders on the former.  
**RESISTING POWER.—Depth of Scour, 35.4 feet below low-water-level. Breaking off point 40.0 feet below low-water-level.**

Description.	Quantities.		Weight.		Leverage.	Power (product of Weight and Leverage).	Remarks.
	c. feet.	cu. feet.	Total weight in lbs.	Lineal feet.			
10 feet well	...	2,963	...	12.778	...	7,996,637	Reduced level of top of girder, ... 205.00
18 feet do.	...	9,568	636,050	15.000	...	8,551,250	Do. bottom of girders, ... 175.60
Pier { portion over } both wells, {	...	4,785	286,750	23.000	...	1,540,448	Do. low-water-level, ... 161.00
Do.—(cap of cut-water) above do., ...	...	598	66,976	9.000	...	2,733,168	Do. top of wells, ... 158.60
Do.—(over 18 feet well), do., ...	...	2,771	201,600	9.000	...	1,814,400	Do. scour, ... 125.60
Girders, planking, rails, &c.,...	...	...	...	...	...	...	Do. breaking off point, 121.00
<b>Power due to Weight and Leverage, ... 17,695,803</b>							
Tenacity of mortar in lbs. per square inch, ...	...	...	...	...	...	...	*Considering the mortar and bricks, together, as one mass, of uniform tenacity.
Corresponding resisting power, ...	...	...	...	...	...	...	
Power due to weight and leverage, ...	...	...	...	...	...	...	
<b>Total Resisting Power, ... 18,175,303 18,894,553 24,888,303</b>							
Difference between low-water-level and that of breaking point, ...	...	...	...	...	...	...	NOTE.—The possible depth of scour in the bed of the Ganges river, has been determined by borings which were taken in the beginning of 1869.
Depths below breaking point to which the wells must be sunk in order that the mass of earth to be displaced, before overthrow can ensue, should give an equivalent resistance to that arising from adhesion of mortar, ...	...	...	...	...	...	...	
<b>Corresponding depths of well sinking below low-water-level,</b>	...	...	...	...	...	...	...
...	...	...	51.3	55	...	63	...



**CAWNPORE GANGES BRIDGE.—(Continued).**

One 18 feet, and one 10 feet well, connected at top, with Pier to carry the Girders on the former.

**OVERTURNING POWER.—Depth of Scour 85.4 feet below low-water-level. Breaking off point 40 feet below low-water.**

Description.	Velocity (lineal feet per second).	Pressure (lbs. per square ft.).	Surface (square ft.).	Leverage (lineal ft.).	Power (product of pressure x surface x leverage.)	Remarks.
Action of current against lower half of well,	6.60	43	306	130	112,896	Velocity of current at surface, ... .. 15 feet per second. (15 feet per second = 10.23 miles per hour.)
Do. do. upper do.	13.33	173	288	29.6	973,962	Velocity at half-way between top of well and scour line. This may be considered as coinciding with the natural bed of river; and all velocities between this level and that at the surface, have been determined, proportionally, according to the distances from either.
Do. do. pier, ... ..	14.44	202	170	46.0	1,042,563	That which, according to Beardmore's tables, would be the corresponding velocity at bottom.
Do. do. floating mass, ... ..	15.00	218	175	54.6	2,082,990	It has been presumed that anything lower is sand, in a state more or less semi-fluid. Approximation is all that can be attempted, as there are certain data on which to found perfectly accurate calculations.
Do. wind against pier, ... ..	...	40	189.4	63.0	458,388	Velocity at greatest depth of scour.
Do. do. against girders, &c., ... ..	...	40	1,200	78.6	3,772,800	The velocity against lower half of a well has been taken as the average between that at bottom of scour and the velocity which, according to Beardmore, would be that at bed of river.
<b>Total overturning power, ... ..</b>	<b>...</b>	<b>...</b>	<b>...</b>	<b>...</b>	<b>8,442,999</b>	That sufficient to impart motion to grains of sand. The pressure of the water in lbs., corresponding to velocity of current, has, in each case, been calculated by the formula $V = \sqrt{2gh}$ . The effective pressure due to current against the wells and piers would, on account of their rounded surface, not exceed two-thirds of that shown in Column 2. For this reason the figures have been multiplied by 0.66.

**NOTE.—**The possible depth of scour in the bed of the Ganges river, has been determined by borings which were taken in the beginning of 1869.

COMPARATIVE TABLE of the proportion between Height and Base.

Description.	CAWSPORN GANGRA.		RAJGHAT GANGRA.		RANGUNGA.		RAIS (JAUPUR).		GUMTI (JAUPUR).		GURRAH.	
	One 18 feet, and one 10 feet well.	Scour, 35 1/4 feet deep.	16 feet well.	Scour, 30 feet deep.	14 feet well.	Scour, 50 feet deep.	16 feet well.	Scour, 25 feet deep.	18 feet well.	Scour, 28 feet deep.	20 feet well.	Scour, 30 feet deep.
Width of base, .. .. lin. ft.	80	80	16	16	14	16	16	16	18	20	14	14
Height of rails, above low-water-level, 1. ft.	44	44	31.5	31.5	29.6	29.6	49.5	49.5	50.7	50.7	33.5	33.5
Depths of breaking off point, below low-water-level, .. .. lin. ft.	40	56	35.0	35.0	60.0	60.0	28.0	28.0	33.0	33.0	30.0	30.0
Do. below breaking off point, to bottom of well, .. .. lin. ft.	15	15	13.0	13.0	12.0	13.0	18.0	18.0	13.5	14.0	12.0	12.0
<b>Total height of rails above plane of fracture, .. .. lin. ft.</b>	<b>84</b>	<b>100</b>	<b>66.5</b>	<b>66.5</b>	<b>89.6</b>	<b>89.6</b>	<b>77.5</b>	<b>77.5</b>	<b>83.7</b>	<b>83.7</b>	<b>52.5</b>	<b>52.5</b>
* Do., do. foundations, .. .. lin. ft.	99	115	79.5	79.5	101.6	102.6	90.5	90.5	97.3	97.3	64.5	64.5
Ratio of height to base (height being measured from plane of fracture), .. ..	2.8	1.33	4.2	1.42	6.4	1.56	4.8	1.48	4.7	1.42	1.88	1.88
Ratio of (height being measured from foundations,) .. ..	3.3	1.38	5.0	1.50	7.2	1.64	6.7	1.67	5.4	1.49	4.6	4.6

These depths and heights correspond to calculations, in which the tenacity of mortar has been taken at 50 lbs. per square inch. The Gurrah wells have been sunk to a depth of 70 feet below low-water-level. The lesser depth (38 feet less) has, however, been assumed, in order to preserve uniformity of system.

COMPARATIVE TABLE OF FLOATING MASSES.

Description.	CAWNPORE GANGES.		RAJCHAT GANGES.		RAMGUNGA.		SAIE JAUNPUR.		GUMTI—(JAUNPUR.)		GURRAH.	
	One 18 feet, and one 10 feet well.	Scour 35'4 feet deep.	Scour 30'4 feet deep.	Without flooring.	With flooring.	16 feet well.	Scour 28 feet deep.	18 feet well.	Scour 28 feet deep.	20 feet well.	Without flooring.	With flooring.
	175	2,082,990	779,000	1,406,000	393,000	175	661,500	677,565	677,565	175	226,800	81,000
A. Assumed superficial area of a floating mass, lying against a pier, with the full force of the current acting upon it. (in s. ft.)	175	2,082,990	779,000	1,406,000	393,000	175	661,500	677,565	677,565	175	226,800	81,000
B. Overturning effect (surface x pressure x leverage) of the above, .. .. . (in lbs.)	921'91	1,202'41	317'77	627'68	144'19	295'31	302'48	302'48	302'48	101'25	36'16	36'16
C. Do do, .. .. . (in Tons.)	5,460	5,460	3,125	3,121	3,121	5,557	5,557	5,557	5,557	3,175	3,175	3,175
D. Weight of a body which, at the tabulated surface velocities, and leverage, would produce, by Impact, an equal overturning Force, (in lbs.)	2'437	2'437	1'395	1'393	1'393	2'481	2'481	2'481	2'481	1'418	1'418	1'418
E. Do, do, .. .. . (in Tons.)	109'2	109'2	62'5	62'42	62'42	111'14	111'14	111'14	111'14	63'5	63'5	63'5
F. Size of timber which, at 50 lbs. per c. ft., would be an equivalent, in weight, to a body producing such Impact, .. .. . (in c. ft.)	10,451,554	10,814,673	2,474,626	..	856,049	3,048,187	5,029,772	7,444,247	7,444,247	2,097,266	1,140,426	1,140,426
G. Excess of Resisting, above Overturning Powers, (tenacity of mortar being taken at 50 lbs. per square inch), .. .. . (in lbs.)	342'44	27'4'04	124'10	28'73	103'40	315'62	793'91	367'00	367'00	19'956	19'956	19'956
H. Weight of a body which, at the tabulated surface velocities, and leverage, might, by Impact, overcome the stability due to the aforesaid excess, .. .. . (in maunds.)	12'230	9'787	4'432	1'026	3'693	11'425	28'354	13'107	13'107	19'956	19'956	19'956
I. Do, do, .. .. . (in Tons.)	410'676	342'272	163'156	18'256	67'732	142'408	389'368	585'088	863'380	406'700	598'472	598'472
J. The contingency of floating masses being left out of the stability calculations, the excess of Resisting above Overturning Powers, will be equal to the sum of B and G, .. .. .	14'667	12'224	5'827	0'662	2'419	5'086	20'896	30'835	30'835	14'525	21'374	21'374
K. Do, do, .. .. . (in Tons.)	14'667	12'224	5'827	0'662	2'419	5'086	20'896	30'835	30'835	14'525	21'374	21'374

REMARKS.—The immersed body may be taken as that of a boat. If this, with its load, present a large surface above water level, when the river is so high as not to admit of its passage under the piers, the overturning effect (not included in these calculations), of a high wind acting upon it, at such a moment, in a down-stream direction, might be considerable. The chances of an accident, would, in such a case, tend to lessen the effect of Impact. Boats at nearly 2,000 maunds burden are infrequently ply on such rivers as the Ganges and Gumti. However, in the event of collision, the mass of the boats is so great that it is from the collision of a floating mass, strong enough to bear the shock, that the danger arises.

*ponding Ratios of Stability.*

		SAIE (JAUNPORE) 66 feet Girders.		GURRAH. 72 feet 6 inches Girders.			
SCOUR, with low-water-level.		SCOUR, 25 feet below low-water-level.		SCOUR, 14 feet below low-water-level.		SCOUR, 3 feet below low-water-level.	
Cylindrical Pier, top of wells taken as a fixed base; and bed of river protected, level, by flooring.		Cylindrical Pier on one 16 feet well.		Cylindrical Pier on one 14 feet well.		Cylindrical Pier, top of wells being taken as a fixed base; and bed of river protected at that level, by flooring.	
	Overturning Power.	Resisting Power.	Overturning Power.	Resisting Power.	Overturning Power.	Resisting Power.	Overturning Power.
24	990,815	5,224,128	2,610,221	3,128,626	1,363,880	1,406,808	510,642
28	1	2·001	1	2·293	1	2·755	1
64	990,815	5,658,408	2,610,221	3,461,146	1,363,880	1,651,068	510,642
64	1	2·167	1	2·538	1	3·233	1
64	990,815	9,277,408	2,610,221	6,232,146	1,363,880	3,686,568	510,642
51	1	3·554	1	4·569	1	7·219	1





---

No. CVIII.

---

## CLAY UNDER-CUTTER FOR WELL SINKING.

[ *Vide* Plate XIL ]

---

BY EDWARD BYRNE, ESQ., *M. Inst. C.E., Exec. Engineer, P. W. D.*

---

THE well-sinking apparatus described, from time to time, in the Roorkee "Professional Papers," are more or less suitable for the removal of sand, clay, or, it may be, other material, from the interior of a well; but, so far as I have noticed, to that alone is their usefulness limited. The following account, therefore, of how a difficulty, to which they would be quite unequal, was overcome by a hurriedly devised clay cutter, may not be deemed without some interest.

The shoeing of well curbs, with a strong, sharp, cutting edge, is manifestly useful where opposing seams of kunkur have to be pierced; but the absence of such an edge, in the Lucknow Goomtee curbs,\* tended considerably to increase the expense of sinking, and aggravate difficulties to an extent that were found, in one case, insurmountable, by any of the ordinary means employed.

Excavation, within the well, was carried to a depth of seven or eight feet below the level of curb, the hole being cut with vertical sides; but, though two hundred tons weight of bricks were afterwards placed on the top, it did not move. The water, which was deep, was fed by too strong a spring to be mastered without pumps, of which none were available; and the divers, unprovided with any suitable dress, came up exhausted, without being able to effect anything.

The obstacle, consisting of a compact clay and kunkur walling, that underlay the curb, was successfully overcome by means of an excavator,

\* The curbs, unfit for the material through which they had to pass, had been made, and the sinking commenced, before I got charge of the bridge.—E. B.

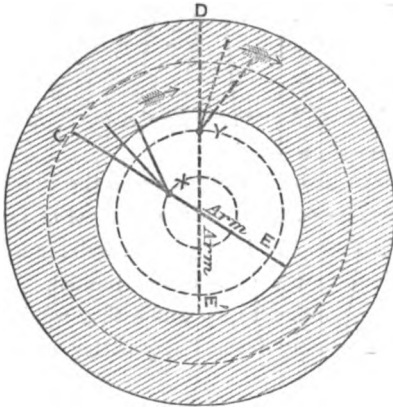
made for the purpose, out of such materials as happened to be close at hand.

To one end of a long wooden shaft, blades of angle iron were attached.



These, three in number, were of unequal lengths; the shortest being that to go first, and prepare the way for the one next longer; which, in like manner, prepared the way for the third, or longest blade.

The shaft, to which was imparted a rotary motion,



by means of a lever handle at top, was made to travel successively on the circular paths X and Y, so that the blades might first cut away the walling as far as C, and then, as far as D—a method that was found to answer exceedingly well, obviating, as it did, the necessity for employing steam power; as well as avoiding the inevitable breakages that would

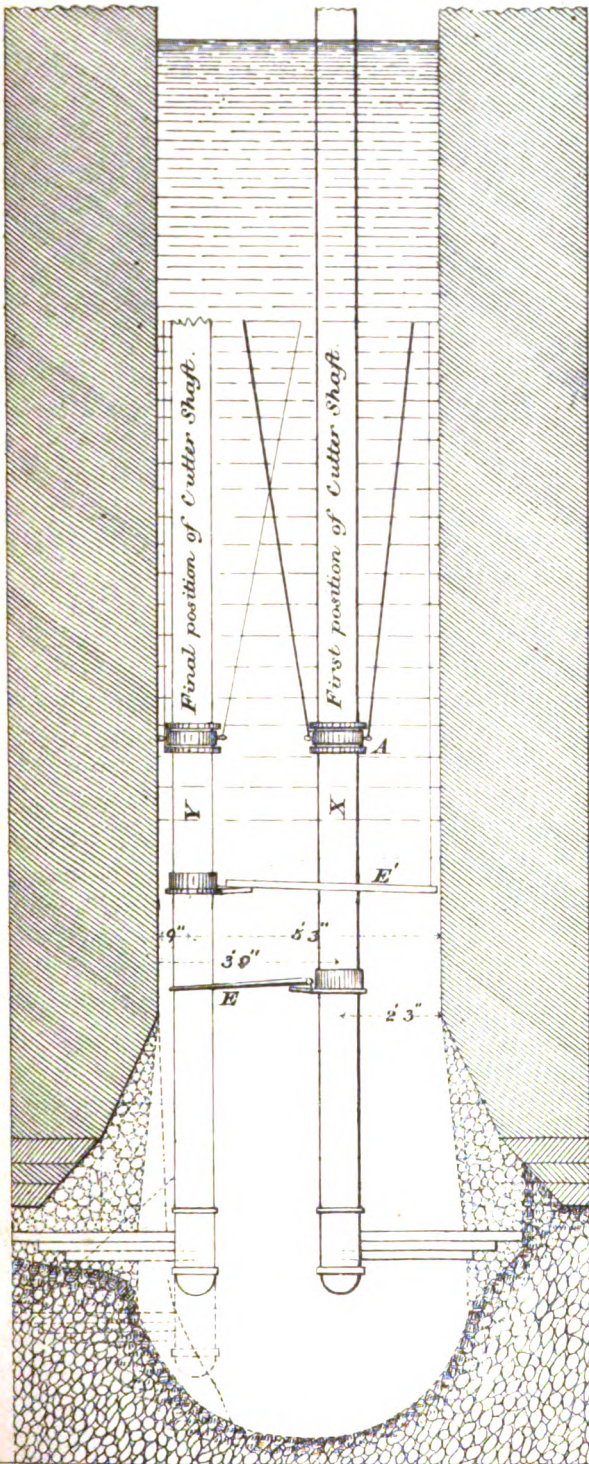
have resulted from trying to remove all the material at once, by using longer blades worked from the centre.

E and E' are arms attached to a sliding collar, and placed opposite to the blades, in order to keep them to their work—E being used with the shaft when it is on the circle X, and E' when it is on the circle Y. On the fast collar A, (*vide Plate XII.*) is a revolving collar, with ropes attached, to facilitate the raising or lowering of the apparatus.

I afterwards saw how it might be improved. It was an inexpensive, and unpretending looking contrivance. *It did the work intended, however,* though introduced by one whose acquaintance with well-sinking appliances, was, at the time, (Autumn of 1869) extremely limited; and whose residence in the country had been so very short, as to save him, it is hoped, from the suspicion, that sometimes falls on longer residents, of passing off as his own, what long previously had been the creation of others.

E. B.

CUTTER FOR THE REMOVAL OF HARD MATERIAL FROM BENEATH A WELL CURB.







## No. CIX.

## EXPERIMENTS ON RAIL JOINTS.

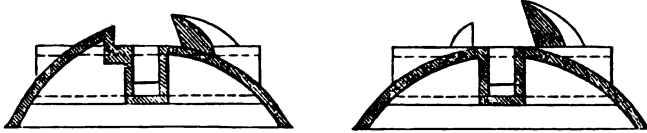
[ *Vide* Plates XIII, XIV, and XV.]BY EDWARD BYRNE, ESQ., *M. Inst. C. E., Exec. Engineer, P. W. D.*

BEFORE joining the P. W. Department, and while on the Oudh and Rohilkund Railway, I had to relay the greater part of the open line between Lucknow and Cawnpore; that is, for the old 36 lb. rails, resting on corrugated iron sleepers, *vide* Plate XIII., to substitute the pot sleeper system of Permanent Way, with 60 lb. rails, *vide* Plate XV., joined by Ibbotson's Steel Clips.

At this very period the Permanent Way of the Khamgaon Railway was being laid with precisely the same kind of rails, sleepers, tie-bars, keys, and joint fastenings; from a report on which, by the Superintending Engineer, Hyderabad, the following remarks are quoted:—

“On the 14th March, 1871, the official opening took place by the Viceroy, when three heavy trains passed over the line, drawn by heavy Goods Engines. The day after, the line was carefully inspected, and found to be seriously damaged. That the line had settled in many places was only to be expected, and could easily have been rectified by ballasting up again, which has been done in some places, to a height of 14 and 15 inches; but, unfortunately, the Permanent Way itself gave way in a very extraordinary manner, which, after careful inspection, I am of opinion was due (though of course primarily to the green banks) to the shape of the pot.”

[NOTE.—Two patterns, as in sketch, were used on the Cawnpore Branch. That of 1869 has one side more vertical than the other. That of 1870 has its sides symmetrical. Both were found to answer well. *Vide* also *Plate XV.* and para. 12, page 94.—E. B.]

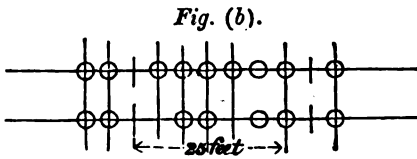


1869 has one side more vertical than the other. That of 1870 has its sides symmetrical. Both were found to answer well. *Vide* also *Plate XV.* and para. 12, page 94.—E. B.]

“When the heavy engines and trains passed over the line the pots gave on the outer edges more than the inner, and the result was that the tie buckled up from  $1\frac{1}{2}$  to  $2\frac{1}{2}$  inches, by actual measurement, thus throwing the gauge out from  $\frac{1}{4}$  to  $\frac{3}{4}$  of an inch, (*Fig. a*).



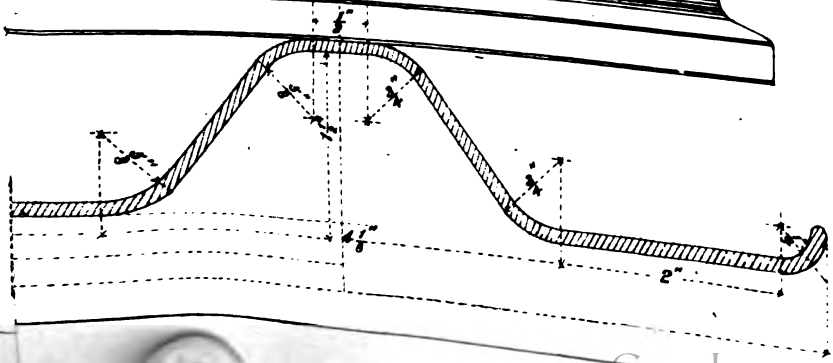
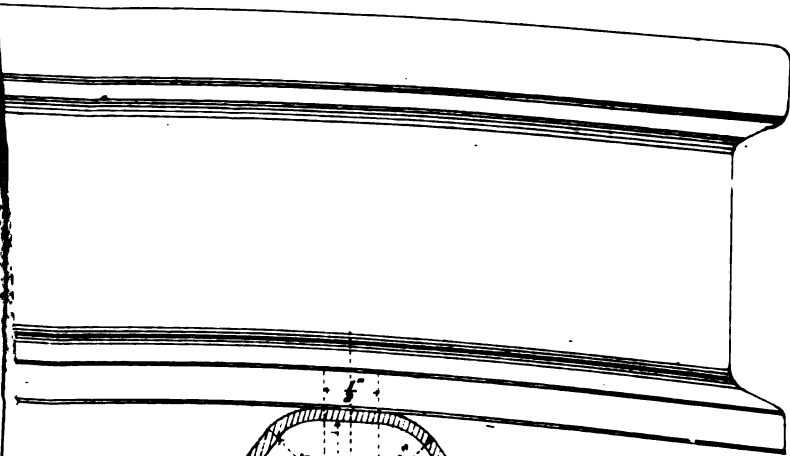
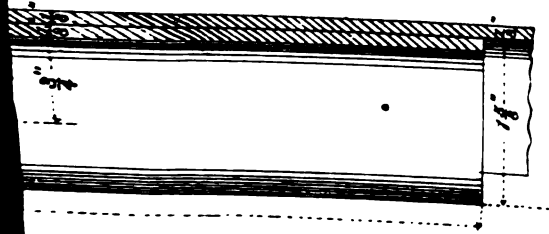
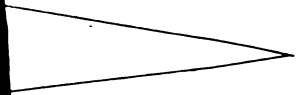
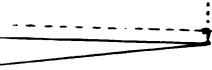
“The tie-bars are being hammered down, and the line is being rectified, as quickly as possible; but I fear it will be always an expensive line to maintain. I would mention here that six\* pairs of pots were laid to every 25 feet rail, and two tie-rods out of every three fixed, as shown in (*Fig. b*)†.



“The next difficulty that the Executive Engineer has had to contend with, is that no allowance has been made for expansion, and this no doubt is the fault of the construction, and not in the laying. The fish-plates are such that, when fixed, the joints of the rails are tight, and the result is, as I witnessed, though the line may be perfectly adjusted in the morning, by the evening it is distorted in every way. They are gradually adjusting this by cutting a rail here and there, and after allowing the line to expand during the heat of the day, boring new holes in the rail and allowing space for the expansion. The bolt holes in the rails even were reported to fit too tight, the bolts being  $\frac{7}{8}$ ”, I suggested to the Executive Engineer, by way of providing means of expansion in each rail, that he should get some  $\frac{9}{8}$ ” bolts which would be quite sufficient, so

\* Seven pairs to every 25 feet rail, were laid on the Cawnpore Branch.

† This is simply evidence of carelessness on the part of platelayers. I insisted on my men using a T-square. (See para. 21, page 96).—E. B.





long as a moderate rate of speed only is maintained. It was a choice between new bolts or new fish-plates.

“The third defect, and which is very serious, is the quality of the material. The chairs are constantly breaking. On examining the broken specimens, I cannot but attribute this to the nature of the material more than to any abuse in driving home the keys too tight. The result of a broken chair is the loss of the whole pot; a very serious affair, not only on account of the cost, but of the difficulty in taking out a pot; the only way being, on account of its being keyed inside, to excavate underneath it and take it out from below, thereby also disturbing the ballasting of the neighbouring pots; the difficulty of re-ballasting which has been already pointed out. With the ordinary chairs and wooden sleepers, the loss of a chair is only a chair, and it is very easily supplied. This is also a very serious objection against the use of this Permanent Way.

“The want of room for expansion, so well as the inferior quality of materials, being defects in construction, may be remedied; but the defective shape of the pots, as also the difficulty of effectually packing and replacing them, are defects in system, quite sufficient, in my opinion, to justify Government in not using them on other lines.”

Owing to such a very unfavorable account, I was called on to make a report upon this Permanent Way, founded on my own experience of that laid by myself—for the information of Government, and the Board of Directors at home.

Subsequently, it fell to my lot to make experiments, by order of the same Board, on rail joints; and of which the results are given in the accompanying Tables.

The experiments 14, 15, and 16, with the clip, in two parts, introduced by Mr. Wilson, on the Lucknow and Cawnpore Branch, gave admirable results, though the extent to which they were carried, was unfortunately limited by the weak section of the 36 lb. rail, which failed completely before the clip itself was even cracked. Its superiority over ordinary fish-plates, made so strikingly manifest by these, and experiments 17 and 18, suggested the idea of conducting those that followed with Ibbotson's fished clips, cut, along the bottom, into two halves.

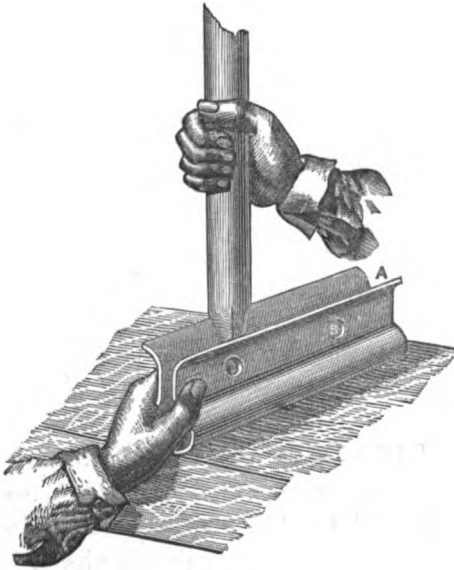
In the General Table (Rails and Rail Joints tested with a falling weight) an instance is given of rail deflection, for comparison with that

of joints. The particular series from which it is has been taken, would not be of general interest. Besides, I do not feel at liberty to insert the experiments in full, intended, as they were, for the purpose of comparing the strength of rails made by different manufacturers. However, the deductions drawn from the several experiments, as well as a summary of my report on the Permanent Way referred to, with such additional observations as have since occurred to me, are given in the following paragraphs.

To render, however, this Article more complete, and for the benefit of such readers as have had no personal experience of Ibbotson's Clip, I preface my notes by a copy of the "directions" issued by the Patentees.\*

The joint consists of only five parts, viz., a steel sheath 12 inches long, two steel

*Fig. 1.*



fish-plates 9 inches long, and two iron set screws, weighing, complete, only 19½ lbs.

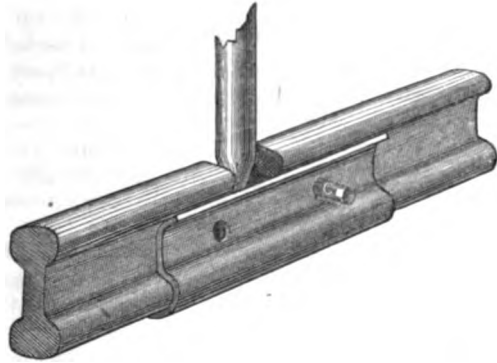
*Directions for placing them on the Rails.*—Each joint with its fish-plates and bolts fitted thereon, and the whole well tarred to prevent rust, is usually sent abroad loose, without packages, and on arrival at its destination, the fish-plates and bolts are temporarily removed, and laid on the ground. The steel sheath is then seized by the left hand, and the point of the ordinary platelayer's crowbar is inserted by the right hand, a little distance from the centre, as shown in *Fig. 1*,† then the steel sheath with point of crowbar in it is brought with a smart blow on to the ground or on to a

sleeper, which blow causes the crowbar by its own weight to wedge itself into the sheath, and so to open it sufficiently from end to end as to enable the workman with the mere

\* The copy of "directions" sent to me, from England, by the Company's Consulting Engineer, was not delivered, as intended, through some unaccountable mistake. *I did not see it until long after the new Permanent Way had been laid, and my report written.* There is nothing, however, in these directions, which could have influenced my opinion.—E. B.

† Unless the sheath be much wedged open so as to fit easily, it gives trouble in fixing—which is objectionable on a line with traffic.—E. B.

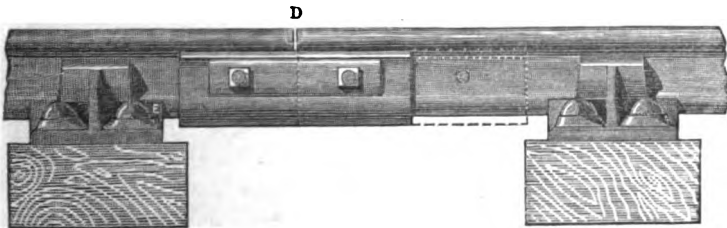
force of his left hand to push the end (A) of the sheath into its exact position on its rail, so that the hole (B) is brought into juxtaposition with the corresponding fish-bolt hole in the rail, when a drift pin, (shown in *Fig. 2*, at C,) or one of the loose

*Fig. 2.*

bolts is temporarily inserted through both to prevent the sheath being driven further on to that rail by the next process, which simply consists in pushing the end of another rail into the remaining open end of the sheath till it touches the crowbar as shown in *Fig. 2*; the crowbar is then withdrawn and the steel sheath at once grips both rails rather tightly; the crowbar is now applied as a lever at the furthest end of the last rail inserted, to push it further into the sheath, *i. e.*, into its proper final position.

The whole process of jointing the rails with one of these sheaths does not therefore need to occupy more than one minute of time, so that a line on which traffic may be commenced with perfect safety, can thus be laid down most rapidly. The fish-plates, with the two bolts to strengthen the joint, and keep both it and the rails permanently in position, can be attached at any convenient time afterwards, without the least interference with the said traffic.

When a rail requires to be replaced, the fish-plates and bolts are first removed, and the sheaths are then easily forced by a few blows of the flat end of an ordinary plate-layer's beating pick, or by means of a simple tool made to pass through the chair, from off one rail their full length on to the next adjoining one, as shown in dotted lines in *Fig. 3*; the old rail is thereupon removed, and the sheath at its end forced

*Fig. 3.\**

off it on to the new rail, which is then put down into its place, and both sheaths are driven quickly back again into their original and final position: or to make the pro-

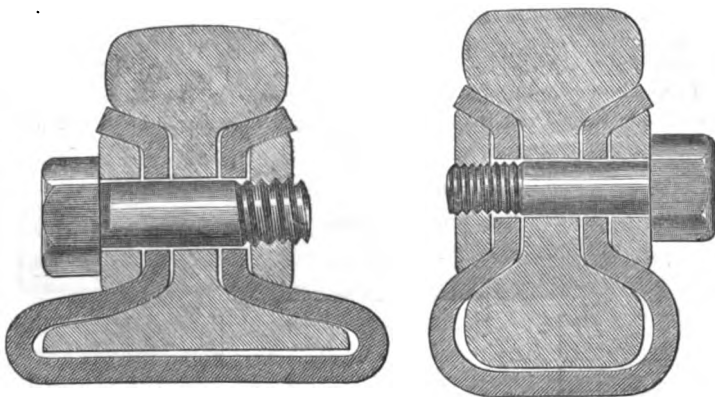
\* On the Oudh and Bohilkund line, for the wooden sleepers and chairs as shown in this figure, Livray's Pot sleepers, (chair and pot combined) were used, *vide Plate XV.*, and *Figs.* on p. 86.—E.B.



cedure still more rapid, a spare sheath may be put upon the new rail before commencing to remove the old one. As however these steel sheaths are usually made 12 inches long, and the distance on most of the English Railways between the bearings on the joint chairs is only about 20 inches, there is not on either rail sufficient length projecting from beyond the bearing on the chair to admit of the sheath being forced thereon its full length flush with the end of the rail as above described, unless the ends of the two rails to be jointed are placed at unequal distances from their bearings on their said joint chairs, as shown in *Fig. 3*, at D, and this mode of laying the rails, as illustrated in said *Fig. 3*, is strongly recommended as a great advantage where these Patent Rail Joints are used, not only because they can then be forced their full length on to one of the rails without necessitating the removal of one of the chairs, but because the wear, tear, and strain upon the joint sleeper of the mounting rail is greatly decreased by reason of the leverage between the point D and E, being thereby so much reduced in length.

These Patent Rail Joints during manufacture are forced through several sets of accurately prepared cast steel dies, to make them all exactly alike; the external fish-plates as well as the bolts, are also made precisely to correspond with the sheaths, and all the parts are therefore interchangeable; so that where a large quantity of rails is being sent abroad at the same time as the joints, one of the sheaths can be placed on each rail flush with one end thereof, and made to grip the rail with sufficient force to retain its position till it arrives at its destination, when, on the rail being laid down, the sheath can be forced half off that rail on to the adjoining one, and the fish-plates with bolts, which can be shipped separately in cases, can afterwards be attached.

Whether the form of rail be of a double-headed section, or flat-bottomed, the mode of putting on the joint is precisely the same.

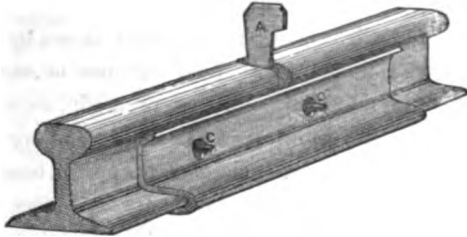


Sectional view of the joint as made for flat bottomed rails.

Sectional view of the joint as made for double headed rails.

*Supplemental directions for connecting the ends of Rails.*—Place a joint on the ground near to the end of the rail already secured in position, unscrew the bolts and

take off the fish-plates, laying for the sake of convenience the *tapped* fish-plate on the ground *inside* the rail and the other on the outside. Exactly in the centre of the sheath drive in a steel wedge, A, *Fig. 4*, which will open it sufficiently to allow of

*Fig. 4.**Fig. 5.*

its being slipped easily on to the fixed rail until the wedge touches the rail. Then slide into the open end of the sheath the end of the other rail and insert in each bolt hole a tapered steel drift <sup>C</sup> as shown at C, *Fig. 5*, withdraw the wedge and drive up the two drifts until the bolt holes in both sheath and rails properly correspond; then knock out the drifts and place the fish-plates in the same position on the sheath they originally occupied, with the tapped fish-plate facing the inner side of the rails, screw in *both* bolts *loosely* and *then* tighten them up, and the fixing of the joint is completed.

The smaller end of the wedge should be slightly "chisel-pointed," as shown at "a" in *Fig. 4*, to allow of its being used either for separating the ends of rails, or for removing a joint.

1. **Ibbotson's Clip.**—*Defective fitting.*—Close and even contact should take place at the sloping underside of the rail head, and at the corresponding portion of the lower flange; but the lips or turned over portions of Ibbotson's steel clips, *as they are used in the work*, are sometimes so much bent at the ends, as not even to touch the rails; while, at the corresponding lower portions, there is often space enough left to admit of inserting the thin blade of a pen-knife between the clip, and the flange of the rail.

2. To carelessness in the manufacture, or a practical difficulty in making the clips true, may be due imperfections that cause trouble in fixing them. However, one of the defects alluded to is undoubtedly owing to rough usage—probably in the operation of unloading; and the other, almost entirely, to the treatment the clips receive in the course of platelaying. That is to say, in order to avoid the trouble and loss of time consequent on dealing with a tight-fitting clip, it is wedged open, before

being slipped on the rail; and, owing to the resistance offered by the foot or bow, no amount of screwing up, afterwards, may be sufficient to bring it back to its original form. In fact, the clips, which were intended to fit as in *Fig. 1*, frequently *misfit* as in *Fig. No. 2*. (*Vide Plate XIV.*)

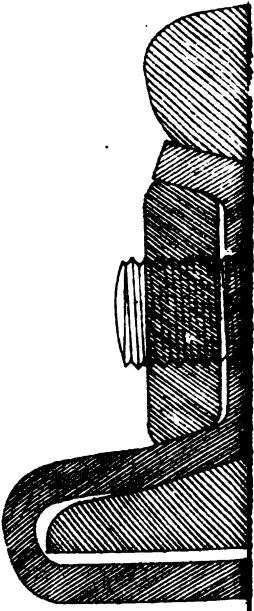
3. These defects, when they occur, shown by dotted lines in *Fig. 2*, are certainly confined to a short distance at each end. Still, they must considerably lessen the efficiency of a clip, *on which the rigidity of a joint is dependent*, by limiting surface contact, where it should take place, to little more than three-fourths of its proper length.

4. *Rigidity.*—As a joint, unless kept down by some counterbalancing weight, is raised when a moving load reaches to within a short distance of either of its bearing points; the extent to which it is so, (depending, in part, upon the manner in which the road is packed, but, chiefly, on the kind of joint itself,) must be added to the registered deflection, in order to ascertain the total amount of play.

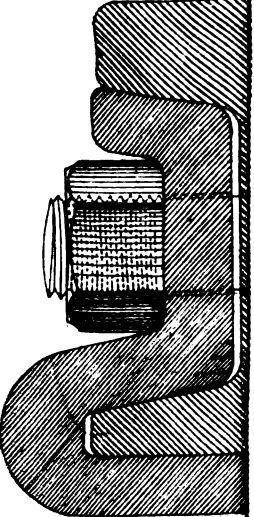
5. With a standing load of about six tons, in the centre of a bearing eight feet four inches long, the deflection of a rail was 1.6 times less than that of a joint, made with two fish-plates, sixteen inches long, and four bolts; *of which joint* the deflection was found to be almost exactly as much less than that of one fished with clips. From this it seems that a line of rails, joined by four-bolted fish-plates, more nearly resembles a perfect roadway in which there is no joint whatever, than that in which clips are used; and, when tested with a moving load, over bearing distances varying from one foot ten inches to six feet, the advantage of one system over another appears to be still more striking.

6. In an emergency, Ibbotson's clip, though deprived of its bolts, might make a safe joint, whereas the fish-plates, with less than two bolts, could not be depended on. As no test, however, to which the latter need be exposed, can possibly result in shearing off three out of four bolts, the matter is not important. Moreover, the truth of the assertion that the former, *without bolts*, would make a sufficiently good joint for the running of ordinary trains, is not borne out by actual experience, because, as a rule, the ends of the rails will not coincide properly, until the sides of the clip are drawn towards each other by actual force.

7. The frequent misfit of Ibbotson's clip is fatal to rigidity. Besides, the difficulty in putting it on a rail is considerable, unless when previously



*Joint of 36 lbs. Rail  
Lucknow and C*



*Scale, two-*





opened out to an extent that must eventually lessen its efficiency; and, if with a view to obtain increased rigidity, the bearing distance at the joints be reduced to the length of a clip, the subsequent removal of a rail would be very troublesome.

8. *Experiments.*—Finally, experiments, of which the results are given in the following tables, have served to prove that the clip form of joint is stronger, and better able to resist the shock of a falling weight, than that of ordinary fish-plates; but, when tested with a standing or moving load, the latter make a much more *rigid* joint. They have served, moreover, to indicate that, possibly, an improved joint may be made by means of a four-bolted clip, in two parts, which might possess the essential advantages of both systems, without the weak points of either (*vide Plate XIV., Figs. 3 and 4, and experiments Tabulated on pages 97 and 98*).

9. *Allowance for Expansion.*—The elongation of the holes in the rails, compared with the diameter of the bolts, is such that, if the clips were truly made, there would be no difficulty whatever in giving an intermediate space of  $\frac{1}{4}$ th of an inch for expansion. But being more or less twisted, so that the corresponding parts of their sides are not opposite each other, there is frequently a want of coincidence in the holes of the clip and of the rail, that renders it difficult to allow anything like that amount. Instances, in fact, have occurred, in which not more than  $\frac{1}{8}$ th of an inch could be obtained, with great trouble, and after the bolts had, of necessity, been forcibly driven through the holes, and partially stripped of their threads.

10. *Relaying.*—With even well made clips, when tight fitting, ample room for expansion, in the operation of *relaying*, cannot always be given, without expending a larger amount of time in the effort to do so, than can well be afforded on an *open line*; the rules of which, imposed by traffic requirements, render very difficult that which, under other circumstances, might be exceedingly simple.

11. *Plate-laying* may be done expeditiously, and at a comparatively low rate, where there is no interruption from running trains, especially those for passengers; because, it might matter little whether that commenced in the morning, be finished or not upon the same day, or within the same week. But where there is traffic, closures have to be made, perhaps hurriedly, soon after commencing to work; and the struggle to effect a

timely closure for an approaching train I have known, more than once, to be made, in a torrent of rain, by those of the gang that had not run away in search of shelter.\*

12. *Pot Sleepers.*—The pot or bowl sleepers employed were those known as ‘Livesey’s patent,’ of combined hollow block and chair in one casting; the iron keys, and key jaws of the chairs to receive them, being corrugated on the surface; (the corrugations are vertical, as shown in Elevation;) and the gauge preserved by ties to each pair of sleepers, placed, on an average, 3 feet 7 inches apart. The portion of key *c* to *d* is corrugated to correspond with surface of jaw, and the way in which the key fits at *f* prevents the rail from being pushed over; the abutting pieces *a*, are not exactly opposite the key jaw. The portion of jaw (*b*), darkly shaded, is a core of cold iron. (*Vide Plate XV.*, and figures page 86).

13. *Keys.*—The cast-iron keys require care in driving, and constant watching after they have been driven, until such time, at all events, as the reduced height of the wooden cushions may admit of driving the keys home. But it is not always possible to drive them in sufficiently far, to be proof against being afterwards shaken out by a passing train, without running the risk of fracture, or breaking off the chairs.

14. *Chairs.*—To effectually resist the shock which attends the insertion of a key, it would be very advisable to strengthen, if possible, the jaws which form the chair portion of the sleepers. Upon close examination, they will be found to contain a core of iron that had been let in cold, with a view to diminish the mass of metal, insure more equal cooling, and obtain, it was hoped, increased strength in the casting. However, even with great care in driving the keys, chairs have often been fractured; and as the contrivance adopted, to obviate this, has been less successful than had been anticipated, the matter is one to which both patentee and manufacturer should give attention.

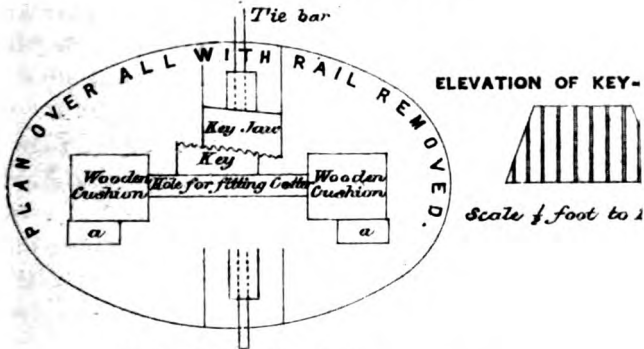
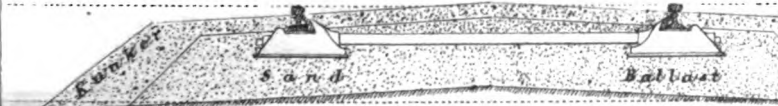
15. If the sleepers be well bedded or packed, the keys may be absent for two, three, or more lengths, without endangering the safety of the road, because the rails would be confined by the upright prominences on the top, against which the outer edge of the lower flanges abut; but if these keys be absent where the bedding or packing is so imperfect as to let the sleepers drop, the rails, which will then be at a higher level than

\* This was in the rainy season of 1870; when moreover, the men I had under me, were new to such work.—E. B.

# EXPERIMENTS ON RAIL JOINTS.

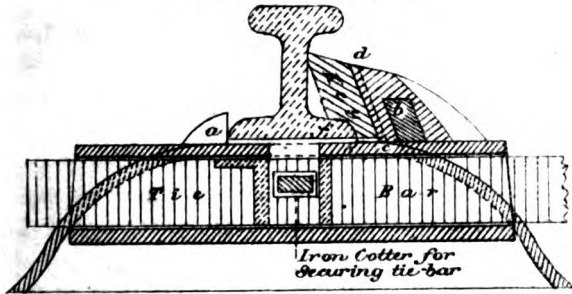
*New Permanent Way of Cawnpore Branch, Oudh and Rohilkun*

CROSS SECTION OF SAND AND BALLAST.



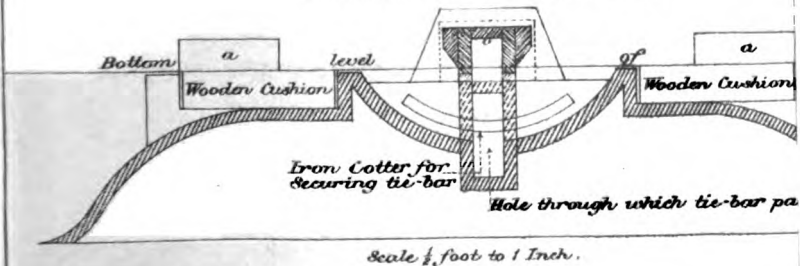
Scale 1 foot to 1 Inch

CROSS SECTION OF SLEEPER.



Scale 1/2 foot to 1 Inch.

LONGITUDINAL SECTION OF SLEEPER.



Scale 1/2 foot to 1 Inch.





these abutting pieces, may *mount over* them, and be forced outwards, *out of gauge*, by a passing train.

16. If a roadway were uniformly rigid, there would be no occasion to bestow more attention on joint sleepers than on others. When, however, the joints are weak, or have too much play, the adjacent sleepers undergo an amount of hammering, during the passage of heavy trains, that tends to knock them down below their proper level. The lower this is, relatively with that of others, the less support will they give to the rails. In fact, when driven very low down, they may give no support whatever. Thus, the bearing points, at each side of the joint, in reality, get transferred to sleepers more remote, until the distance between them becomes, it may be, quadrupled. As a consequence, depressions, at the joints, are rendered excessive; damage, to the rails, imminent; and travelling far from pleasant.

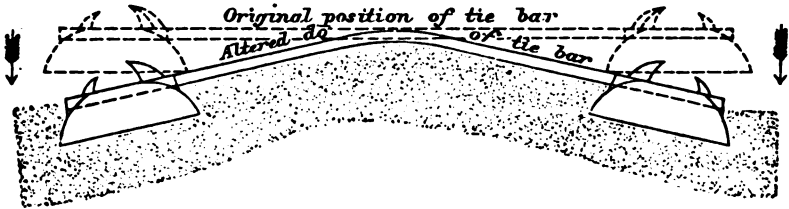
17. *Bedding*.—It has been remarked that the safety of the pot sleepers, whether packed with sand, with kunkur, or not packed at all, has been secured by having them bedded on a smooth surface of sufficient resistance to prevent sinking by heavy pressure. A clay surface will not answer, because it becomes too soft in time of rain; and if an excessive depth of sand be employed, especially when light, the repeated liftings of the road, to which it would give rise, might cause the maintenance, for sometime afterwards, to be very expensive.

18. The best portion of the road—that which, moreover, has cost the least to maintain, and where no sleepers have been broken, is where little sand has yet been used, but where this little (enough for packing only) rests on a well levelled surface of the old kunkur—that which lay undermost, which had been *rammed* originally, and which was left in, as forming a useful crust of small, well consolidated, and, to some extent, impenetrable material.

19. *Consolidation of Bank*.—There can be no doubt that much of the success met with on the Cawnpore Branch, has been due to a thorough consolidation of the banks, as also to a proper levelling of the surface, on which the new Permanent Way has been laid; and, from what has been stated in the preceding paragraph, it may be inferred, that consolidation, so essential in the earthwork, would be attended with advantage in the substratum of ballast, if only for a width of two or three feet, on each side; to serve as a firm foundation on which to place the coarsest pro-

curable sand, which should be of moderate uniform depth, and confined, as much as possible, to avoid escape. Almost as in masonry, equal subsidence cannot harm them; whereas, irregularity, in this respect, would be putting castings to a test for which they were never intended.

20. The system of forming banks in layers, and then converting them on the top, into a series of shallow tanks, or catch-water basins, will in-



sure consolidation. If, however, on carelessly constructed, ill consolidated banks, any Permanent Way be laid and ballasted, the early effects produced by heavy loads passing over it, will be unequal sinking of the earthwork, and a partial forcing into it of such ballast as may lie beneath the sleepers; while, comparatively speaking, the middle portion of the road will remain unchanged. Resting thus, in the centre, upon some unyielding material, and forcibly taken down, at each end, by the sleepers to which they are keyed, as a matter of course the tie-rods must bend.

21. A practised eye may detect a small deviation from a right angle; but, both for accuracy, and despatch, a T-square should always be used in placing the tie-rods.

22. *Packing.*—It was observed, upon lifting up the sleepers, that they had been satisfactorily filled; and in cases where very small kunkur or clayish material, to bind the sand together and save it from dissipation, had formed a component part of the ballast, the packing was found to have taken, even to the innermost crevices, an exact impression of the bowl itself. The sleepers, moreover, have *not* tilted—the tie-rods have *not* buckled up; nor, will they do so, as long as the former be firmly supported, and the latter left free in the centre.

23. *Replacing sleepers.*—As to the difficulty of replacing a bowl sleeper, it is enough to say that, with a little practice, natives become expert in the operation. The keying of the tie-bars beneath the rail, inside the sleeper—that which, in fact, gives rise to an alleged inconvenience, is, in

point of security, a good arrangement; while, the certainty with which the line may be kept in true gauge, is a very essential point, and one on which great value should be set. Besides, the bearing afforded by two points of support, is one advantage gained by using these sleepers; and the elasticity in the road, imparted by the wooden cushions, is another.

24. Cast-iron sleepers certainly require more careful handling than those of wood; but, if the conditions to insure success be at first properly carried out, the maintenance of a Permanent Way, in which the former have been used, ought, in a country like India, be eventually less expensive than one in which the latter have been employed. However, for a *narrow gauge*, with light loads, a system like that of the old Permanent Way,\* as first laid down on the Cawnpore Branch, might be more suitable than either.

\* Taken up in order to relay the line with heavier rails, and stronger sleepers. (See Plate XIII.)  
VOL. III.—SECOND SERIES. O

EXPERIMENTS ON RAIL JOINTS.

CLIP, WITH STIFFENING PLATES.

Distance between bearing points.	Particulars.	LOCOMOTIVE AT REST.			VELOCITY OF LOCOMOTIVE 5 MILES PER HOUR.			VELOCITY OF LOCOMOTIVE 10 MILES PER HOUR.			VELOCITY OF LOCOMOTIVE 20 MILES PER HOUR.		
		Deflection in inches.			Deflection in inches.			Deflection in inches.			Deflection in inches.		
		At middle of joint.	At bearing points (Average).	Deflection due to joint.	At middle of joint.	At bearing points (Average).	Deflection due to joint.	At middle of joint.	At bearing points (Average).	Deflection due to joint.	At middle of joint.	At bearing points (Average).	Deflection due to joint.
1 foot, ...	...	.119	.108	.011	.158	.127	.031	.203	.150	.053	.290	.160	.070
1 foot, 11 in.,	...	.093	.075	.018	.169	.093	.076	.219	.099	.130	.240	.102	.138
3 feet, ...	One side of line,	.166	.112	.054	.250	.135	.115	.320	.137	.183	.370	.160	.210
	Opposite do., ...	.200	.123	.078	.310	.140	.170	.358	.158	.200	.385	.159	.226
	Averages, ...	.183	.117	.066	.280	.138	.142	.339	.148	.191	.377	.159	.218
4 feet, ...	One side of line,	.186	.101	.085	.284	.127	.157	.340	.145	.195	.345	.150	.185
	Opposite do., ...	.202	.109	.093	.430	.188	.292	.470	.147	.223	.640	.153	.485
	Averages, ..	.194	.105	.089	.357	.133	.224	.405	.146	.259	.492	.152	.340
6 feet, ...	One side of line,	.353	.148	.205	.615	.175	.440	.630	.185	.445	.750	.185	.565
	Opposite do., ...	.472	.199	.273	.750	.230	.520	1.200	.230	.470	1.280	.240	.990
	Averages, ...	.412	.173	.239	.682	.202	.480	.915	.208	.707	.990	.213	.777
8 feet, 4 in., ...	One side of line,	.466	.175	.291	...	...	...	...	...	...	...	...	...
	Opposite do., ...	.824	.286	.538	...	...	...	...	...	...	...	...	...
	Averages, ...	.645	.230	.415	...	...	...	...	...	...	...	...	...

NOTE.—Of the four cases (sets of experiments) given in the preceding General Table, this has been selected, to show how the average deflections were obtained. Details of the other three are omitted, in order to avoid unnecessary bulk.

GENERAL TABLE.—PERMANENT WAY.—Rails and Rail Joints tested with a falling weight of 1,291 lbs.  
(Distance between bearing points, 4 feet.)

Height of fall, in feet.	Momentum of blow, in lbs.	AVERAGE DEFLECTION, IN INCHES.										Remarks.
		60 LBS. RAIL.—NEW PERMANENT WAY.					36 LBS. RAIL.—OLD PERMANENT WAY.					
		Ibbotson's Steel Clip.		Fish Plates.			Rail, 36 lbs. per lineal yard		Wilson's Clip, with four 3/4" bolts.		Fish plates 1 1/2" long, 3/4" thick, with four 3/4" bolts.	
0.50	7,350	0.25	0.26	0.62	0.50	0.50	0.50	0.25	0.31	0.77		
1.00	10,305	0.88	0.90	1.59	1.25	1.30	1.30	0.85	0.85	2.02		
1.50	12,731	1.65	1.77	2.69	2.39	2.40	2.40	1.70	1.69	3.58		
2.00	14,639	2.66	2.87	3.88	3.38	3.42	3.42	3.05	2.65	...		
2.50	16,435	4.00	4.40	4.60	4.75	4.77	4.77	4.60	...	...		
3.00	18,004	...	...	...	...	...	...	Broke	...	...		
3.50	19,447	...	...	...	...	...	...	...	...	...		
4.00	20,790	...	...	...	...	...	...	...	...	...		
4.50	22,051	...	...	...	...	...	...	...	...	...		
5.00	23,243	...	...	...	...	...	...	...	...	...		

The average amount of deflection, in each case, has been given up to the point where further testing resulted in breakage, or absolute unfitness for use.  
The deflection of rails was ascertained by another, special, series of experiments.

See paragraph at top of page 84, and also 5th paragraph, page 92.

Description.	WEIGHT.		
	Clip.	Fish plates.	Bolts and nuts.
Ibbotson's Clip, with stiffening plates, ...	lbs. 13-25	lbs. 4-50	lbs. 1-75
Do. without do. ...	13-25	...	2-75
Fish plates, 12" long, 1/2" thick, with two 3/4" bolts, ...	...	14-90	2-75
Do. 16" do. four do. ...	...	17-50	5-50
Wilson's Clip, 14" long, 1/2" thick, with four 3/4" bolts, ...	18-75	...	2-75
Fish plates, 14 1/2" long, 3/4" thick, with four 3/4" bolts, ...	...	12-25	4-00
Fish plates, 14 1/2" long, 3/4" thick, with four 3/4" bolts, ...	...	...	16-25

PERMANENT WAY.—Rail joints tested with a falling weight of 1,291 lbs.

(Distance between bearing points, 4 feet.)

Number of experiment.	Description.	Height of fall in feet.	Momentum of blow in lbs.	Deflection caused by blow, in ins.	Remarks.
1	Steel clip, with stiffening plates, (rail, 60 lbs., per lineal yard), ... ..	0.50	7,350	0.30	Buckled out, at top, in the centre, $\frac{1}{4}$ "
		1.00	10,395	1.04	do., $\frac{1}{2}$ "
		1.50	12,731	1.86	do., $\frac{3}{4}$ "
		2.00	14,699	2.90	do., $\frac{1}{2}$ "
		2.50	16,435	4.46	do., $\frac{1}{2}$ "
		3.00	18,004	...	One bolt sheared off. Clip and stiffening plates much distorted, and unable to give any support.
2	Do. do., do.,	0.50	7,350	0.20	Buckling out same, approximately, as in first experiment
		1.00	10,395	0.80	Do. do.
		1.50	12,731	1.50	Do. do.
		2.00	14,699	2.80	Do. do.
		2.50	16,435	3.15	Do. do.
		3.00	18,004	...	One bolt sheared off. Clip and stiffening plates much distorted, and unable to give any support.
3	Do. do., do.,	0.50	7,350	0.25	Buckling out same, approximately, as in first experiment.
		1.00	10,395	0.80	Do. do.
		1.50	12,731	1.60	Do. do.
		2.00	14,699	2.80	Do. do.
		2.50	16,435	4.40	Do. do.
		3.00	18,004	...	Both clip and stiffening plate cracked on one side, below one of the bolts. Unfit for further use.

4	Steel clip, without stiffening plates, (rail 60 lbs, per lineal yard), ... ..	0.80	7,850	0.88	Buckling out, approximately, as in first experiment.
		1.00	10,395	1.06	Do.
		1.50	12,731	2.84	Do.
		2.00	14,699	3.96	Do.
		2.50	16,435	4.88	One bolt sheared off. Clip much distorted, and spread out considerably at same end. Unfit for further use.
5	Do.	0.50	7,350	0.55	Buckling out, approximately, as in first experiment.
		1.00	10,395	1.50	Do.
		1.50	12,731	2.75	Do.
		2.00	14,699	4.80	Piece, at end of clip, broken off on one side. One bolt sheared off.
6	Do.	0.50	7,350	0.48	Buckling out, approximately, as in first experiment.
		1.00	10,395	1.48	Do.
		1.50	12,731	2.48	Do.
		2.00	14,699	3.88	Do.
		2.50	16,435	4.88	One bolt sheared off, clip distorted.
7	Fish-plates, 12' long, 1" thick, with two 1/2" bolts, (rail, 60 lbs. per lineal yard), ... ..	0.50	7,350	0.50	Buckling out scarcely perceptible. { Neither fish-plates, nor bolts broken. { Rail (E. V. A. 1869) broken in vertical web, and failed partially in upper table.
		1.00	10,395	1.25	
		1.50	12,731	2.50	
		2.00	14,699	3.25	
		2.50	16,435	4.50	
8	Do.	3.00	18,004	...	Buckling out scarcely perceptible. { Neither fish-plates nor bolts broken. { Rail (E. V. A. 1869) failed, by piece coming out at one of the bolt holes.
		0.50	7,350	0.60	
		1.00	10,395	1.40	
		1.50	12,731	2.60	
		2.00	14,699	3.70	
		2.50	16,435	5.00	
		3.00	18,004	...	



PERMANENT WAY.—Rail Joints Tested.—(Continued).

Number of experiment.	Description.	Height of fall in feet.	Momentum in lbs.	Deflection caused by blow, in ins.	Remarks.
9	Fish-plates, 12' long, $\frac{1}{2}$ " thick, with two $\frac{1}{2}$ " bolts, (rail, 60 lbs. per lineal yard), ...	0.50	7,350	0.40	Buckling out scarcely perceptible. Fish-plates not broken, but both bolts sheared off.
		1.00	10,395	1.10	
		1.50	12,731	2.07	
		2.00	14,699	3.20	
10	Fish-plates, 16' long, $\frac{1}{2}$ " thick, with four $\frac{1}{2}$ " bolts, (rail, 60 lbs. per lineal yard), ...	2.50	16,435	..	Buckling out very trifling. Fish plates, both sides, broken completely across, at one bolt hole. { Rail (Blacuavon) gave in web, at same bolt hole.
		0.50	7,350	0.50	
		1.00	10,395	1.35	
		1.50	12,731	2.40	
		2.00	14,699	3.45	
		2.50	16,435	4.75	
11	Do. do., do., do., do., do., do.,	3.00	18,004	..	Buckling out very trifling. Fish-plates, on both sides, gave below one of the bolt holes. One bolt sheared across.
		0.50	7,350	0.61	
		1.00	10,395	1.45	
		1.50	12,731	2.50	
		2.00	14,699	3.48	
		2.50	16,435	4.96	
12	Do. do., do., do., do., do.,	3.00	18,004	..	Buckling out very trifling. Fish-plates gave as in Experiment No. 11.
		0.50	7,350	0.40	
		1.00	10,395	1.28	
		1.50	12,731	2.30	
		2.00	14,699	3.82	
		2.50	16,435	4.60	
		3.00	18,004	..	

13	Clip, in two parts, 14' long, with four $\frac{3}{4}$ " bolts, as employed in fishing the joints of the old Permanent Way, between Lucknow and Cawnpore, (rail, 86 lbs. per lineal yard), ... ..	0.50 1.00 1.50 2.00	7,350 10,395 12,731 14,699	0.97 1.25 2.62 ...	One end bolt, with very weak thread, became useless. End bolt sheared off, and the two halves of clip, at same place, buckled out.
14	Do. do., do., do., (The $\frac{3}{4}$ " worn out bolts being replaced by new bolts, $\frac{3}{4}$ " in diameter), ... ..	0.50 1.00 1.50 2.00 2.50	7,350 10,395 12,731 14,699 16,435	0.33 0.80 1.53 2.70 ...	Web of rail much injured—portion torn out. Clip neither broken nor cracked. Bolts uninjured.
15	Do. do., do., do.,	0.50 1.00 1.50 2.00 2.50	7,350 10,395 12,731 14,699 16,435	0.35 0.83 1.55 2.45 ...	Rail, at one end bolt hole, completely broken across. Clip and bolts as in Experiment No. 14.
16	Do. do., do., do.,	0.50 1.00 1.50 2.00 2.50	7,350 10,395 12,731 14,699 16,435	0.25 0.90 1.70 2.80 ...	Same, exactly, as in Experiment No. 15.
17	Fish-plates, 14 $\frac{1}{2}$ ' long, $\frac{3}{4}$ " thick, with four $\frac{3}{4}$ " bolts, (rail, 86 lbs. per lineal yard), ... ..	0.50 1.00 1.50 2.00	7,350 10,395 12,731 14,699	0.75 2.00 3.50 ...	Both fish-plates sheared completely across.
18	Do. do., do., do.,	0.50 1.00 1.50 2.00	7,350 10,395 12,731 14,699	0.80 3.05 3.66 ...	Both fish-plates sheared completely across.

PERMANENT WAY.—Rail Joints Tested—(Continued).

Number of experiment.	Description.	Height of fall, in feet.	Momentum of blow, in lbs.	Deflection caused by blow, in ins.	Remarks.
19	Ibbotson's fished steel clip, divided into two parts, a piece $\frac{1}{2}$ " wide, having been cut out of the bottom, (rail, 60 lbs. per lineal yard), ... ..	0-60	7,350	0-17	
		1-00	10,395	0-60	
		1-50	12,781	1-25	
		2-00	14,699	2-25	
		2-50	16,435	3-45	One side of clip cracked at bolt hole. Piece broken off clip at do.
20	Do. do., do., do., do., do.,	0-50	7,350	0-35	
		1-00	10,395	1-20	
		1-50	12,781	2-30	
		2-00	14,699	3-50	
		2-50	16,435	...	Both bolts sheared off, and clip jumped out.

E. B.

1 bolts  
 20  
 222  
 180  
 142  
 255  
 198  
 157  
 141  
 130  
 122  
 114  
 106  
 98  
 90  
 82  
 74  
 66  
 58  
 50  
 42  
 34  
 26  
 18  
 10  
 2  
 when ru

TABLE OF ORDINARY FISH-PLATES.

No. of bolts.	FISH-PLATES. 16 inches long, with 4 bolts.					Remarks.
	Velocity of Locomotive in miles per hour.					
	20	0	5	10	20	
..	..	..	..	..	..	
..	..	..	..	..	..	
..	..	..	..	..	..	
5	.322	.113	.165	.170	.178	
5	.180	.108	.129	.130	.135	
0	.142	.010	.036	.040	.043	
5	.355	.214	.273	.301	.306	
3	.198	.177	.205	.214	.216	
7	.157	.037	.068	.087	.090	
5	..	.208	.276	.299	.299	
4	..	.143	.164	.169	.169	
1	..	.065	.112	.130	.130	
0	.622	.262	.372	.447	.460	
0	.204	.139	.168	.180	.186	
0	.418	.123	.204	.267	.274	
..	..	.426	..	..	..	
..	..	.226	..	..	..	
..	..	.200*	..	..	..	

The deflection was first taken with a Locomotive at rest, and then when in motion. It was found to increase with that of the velocity, though, in some cases, there was an apparent exception to this rule. But, owing to the jerking action of the Indicators as communicated, through the rail, by a load moving at a high speed, it is probable that the actual deflections, corresponding to greater velocities than that of 5 miles an hour, were less than those registered.

These figures represent average deflections, as shown by the following Table (clip, with stiffening plates).

* Deflection of rail, similiary tested.			
At centre of rail, ... ..	...	...	.473
„ bearing points, ... ..	...	...	.349
Difference (actual deflection of rail),			.124

When running at the rate of 5, 10, and 20 miles an hour, approximately.





No. CX.

---

ON THE ADOPTION OF THE METRE GAUGE FOR THE  
STATE RAILWAYS IN INDIA.

---

By C. H. G. JENKINSON, Esq., *Assoc. King's College, London, and Assistant Engineer, Western Rajpootana (State) Railway.*

---

ONE rises from the perusal of the discussion on the paper by Mr. Thornton, C.B., of the India Office, read before a Meeting of the Institution of Civil Engineers, and published in their Minutes on the advantages of the Metre Gauge for India, with a feeling of satisfaction that the Author has been able to make out a good case for the Metre Gauge, even in the case of the Northern Punjab and Indus Valley Railways, in spite of the almost universally expressed opinion against any break of gauge at Lahore, or between Lahore and Mooltan.

The question of the expediency of making an expensive railway through a country, where that, nor yet a cheap one, can hardly be expected to be a commercial success, is one for the Statesman, and not for the Engineer. And here it must be said that the Author of the paper has enlisted on his side the sympathy of Lord Lawrence, our former Viceroy, than whom no one can be said to be better acquainted with the Punjab. The discussion turns chiefly on the evils of break of gauge, especially in the two Railways just mentioned, and to support the argument, it is endeavored to be shown, that no real advantage is gained in the first cost, or in expense of maintenance, but rather the reverse. But it is remarkable that Engineers who have been connected with narrow gauge lines, as Messrs.

Brullees, C. Douglas Fox, E. W. Young, Captain Tyler, R.E., and others have not in their experience found narrow gauge railways to disappoint the expectations formed of their success; and they still advocate the system, subject to the qualification that it must be suited to the country; a question more fitted to be decided on the site of the railways, than in the meeting room of the Institution, or in an Engineer's office in London.

The greatest opposition to the introduction of another gauge seems to be (putting aside those whose pecuniary interest would suffer by it) from Engineers whose practice has not led them to think of countries under much different circumstances to England, and from venerable Members of the Profession, whose spirit is still stirred within them at the sound of another "Battle of the Gauges," such as they fought so well, and to so great an advantage, in their younger days.

In the discussion on the paper, the policy of Government is declared by Mr. C. D. Fox, (a great advocate of narrow gauge,) as "suicidal" in regard to the Northern Punjab and Indus Valley Railways; it is also much condemned by all military commanders, though the lines are declaredly only made for strategic purposes; and public opinion in this country is universally against any break of gauge on the North West Frontier, though it does seem to any one looking at the map that a narrow gauge might suffice from Kurachee to Lahore, especially remembering the barren country traversed, and the competition there would be with the river. But it appears now more than probable that these two railways will be made on the 5' 6" gauge. If they are, it may be suggested that, for the same reasons there are against a break of gauge, the railway, at all events from Lahore to Peshawur, should be continued on the *same type* as the existing railways, capable of bearing the same rolling stock and locomotives, running at the same speed; for, if the locomotives are to be debarred from the extension, there might be on emergencies a deficiency of tractive power from Lahore onwards.

Now looking at the map of India, accepting that the Northern Punjab and Indus Valley Railways will be executed on the broad gauge, we see, commencing from the south, one continuous railway zig-zaging across the country. From Beypore to Madras, Hyderabad, Bombay, Nagpore, Allahabad, Calcutta, Agra, Delhi, Lahore, Peshawur, Mooltan and Kurrachee, touching the coast at no less than five points; passing through all the

great arsenals and commercial centres of India; and a railway capable of conveying the heaviest material at the highest speeds: no less than 4,000 miles in length, and having cost more than £10,000 per mile; in fact £10,000 is nearly a minimum.

There is yet wanting for the railway system which it is desirable to complete within the next few years a length of 10,000 miles of railway, which if provided at the same price per mile as the existing lines, would cost the country £100,000,000, or more than two years gross income.

Such an expenditure is impossible unless spread over a very long time, thus deferring for long the increase of wealth and prosperity reasonably to be expected from the spread of railway communication.

Hence the wise determination of Government to build in future only cheap railways, and such as can be maintained cheaply; to secure their object, they have decided to introduce a smaller gauge which they consider more suited to the requirements of the country.

Of course there are many opponents to such a radical change, and it is urged that little or nothing is gained in first cost, that the maintenance will even be more costly, and lastly the object of Government would be better attained by the introduction of light and cheap railways of the existing gauge. There are even some to be found who are bold enough to assert that the existing type of railway may be made very nearly as cheaply as any light lines hitherto proposed, so that the saving, if any, is worth nothing.

The only answer worth giving to the latter is, to ask why all the Indian railways have on an average cost such enormous sums, out of all proportion to the wealth of the country. They traverse an exceptionally plain country for the greater part of their length, and the average of heavy works on them cannot be said to be exceptionally high. Is the reason this—that the proprietors of the lines and their servants have not sufficient interest in the country, and because the former, living in England and never thinking of their property, except to receive 5 per cent. on it when it becomes due; the latter only of their pay, and contemplating only a short residence in the country, do not consult the best interest of the inhabitants for doing which the public servants of this country have ever been justly famed?

The accusation is not to be denied, and no one can have travelled far in



this country by railway without remarking the profuse liberality with which money has been spent, without the smallest regard to the wants of the country, or indeed to the habits of the natives. The Government therefore has been wise to undertake the construction of new lines itself, and to entrust the work to men who look forward to a lengthened residence in India, and who can hardly help in a measure identifying themselves with the interests of the country they have adopted for the best years of their lives.

Many advocate the adoption of Light Railways on the 5' 6" gauge to avoid "a break of gauge," considered by many the greatest of evils wherever it occurs. These men say that light broad gauge railways, such as the Oude and Rohilcund, can be built for the same price as the metre gauge, but experience in India does not bear this out. The original permanent way of the railway instanced, was laid light with a 36 lb. rail, but has been relaid with a 60 lb. rail, as it would not bear the heavy wagons of the East India Railway which were allowed to traverse it. The speed is miserably slow, not that that is an objection in this country, but its increase would have been dangerous with the original permanent way of 36 lb. rail, laid on small square plates of corrugated iron. The rolling stock is built in the lightest way, and is liable to be mixed in the same train with the very heavy stock of the older railways, and that must be to its own detriment.

Now, is such a railway so efficient as a narrow gauge railway? supposing it to keep to its original light permanent way, for of course it may strengthen its stock and way, until it becomes a bad imitation of the older lines, only unable to transmit large loads as the locomotives are limited in weight.

The break of gauge effectually checks the tendency always manifested to strengthen the line, to provide for the weight of foreign stock. The permanent way of the narrow gauge is first class with a light rail suited to the weights to be taken over it, &c. If necessary, the speed may be increased at times without danger to more than 30 miles, for it is the small diameter of wheels of the stock which practically limits the speed. The strength of the stock of the narrow gauge is more proportioned to its size, and may fairly be expected to stand more rough usage than the light stock of the light broad gauge railway.

Mr. G. Berkley in the discussion, takes exception to the size of a

wagon mentioned by General Strachey having a gross weight of 16 tons. The General does not say where that wagon is;\* but wagons weighing between 5 and 6 tons and carrying 9 tons, have come under the writer's notice in Madras. That is a total load of from 14 to 15 tons on two axles.

This is an ordinary waggon on the Madras Railway, and differs only from many others there of the same weight, but carrying not more than 6 tons, in improved axle boxes. The lubrication in the former case being oil, and in the latter the old grease.

Could a wagon bearing so good a proportion between paying and non-paying weight, be constructed to suit the requirements of a light railway on the same gauge?

Supposing it could be made, how is a waggon of such large capacity to be profitably filled? Where they are in use, a few heavy commodities are found to fill them, such as pressed cotton and salt, and it is to be remembered that this is no exceptional wagon, but one proportioned in size to the gauge. In fact the capacity of the 5' 6" gauge is too great for India. Gauge must surely have something to do with the capacity of well proportioned wagons; so the capacity of the 4' 8½" wagon would be less than the 5' 6" "gauge" wagon, and yet we see the enormous traffic of the London and North Western carried on a smaller gauge than was considered necessary for India; when its traffic gets unmanageable on two lines, it lays-down three, and then four.

Any one who has been a short time in India must have observed that the wants of the people are small; and the trade of country towns is limited to the simple wants of the people there, and of the surrounding villages: there is little to send away, as the produce of the country is chiefly consumed there. So the trade is very little, and it seems folly to provide for it wagons, one or two trains of which would convey the merchandize of a whole year.

The principle to guide us seems rather to be the subdivision of the load of a train into a number of small and well loaded wagons; so that full wagons may be detached at a station, instead of having been hauled half empty for many miles; or a wagon having been left empty at a station, may be refilled without inconvenience arising from its demurrage or

\* Since writing the above the author has seen a wagon on the E. I. R., whose gross weight was over 17 tons on three axles.

necessitating its being attached to the train without its complement of load.

Hence in the country for which we have to provide railways, accepting for sake of argument, that the light 5' 6" gauge railway may be made for the same price as the metre gauge, the conclusions we arrived at are, that it is not so efficient, and cannot be worked to so great an advantage, in other words would not pay so well. It is evident too, that a paying railway will bring more indirect advantage to the surrounding country, than one paying less, not to say not at all. Therefore we are brought to the conclusion, that the Indian Government has best supplied the true wants of the country by ordering the reduction of gauge.

It is argued by the opponents of the metre gauge scheme, that the saving consequent on the reduction of gauge is small, not more than £200 per mile, and does not compensate the country for the great evil of a break of gauge.

Supposing the utmost saving to be only £200 per mile, then in 10,000 miles the saving will be £2,000,000, and the sum however paltry is worth saving. And the evil of break of gauge cannot be shown to exist.

The poverty and extent of this country are not sufficiently appreciated in England. People there forget that the income of a country, in which England would appear but a very small state of the empire, has an income less than three-fourths that of Great Britain; and though two millions more or less would be thought nothing of in England in the expense on such a vast system of railways, yet in India, where roads, railways, and irrigation works are all wanted at once, the smallest sums saved from the expense of one, goes to enable the others, which are of no less importance, to be carried out.

As to the difference in first cost between a broad gauge and narrow gauge railway, the extremes gone to by the advocates of either system, and the great discrepancies in the conclusions arrived at, suggest the idea that no one has studied the subject without a foregone conclusion; some endeavoring to make the difference as high, others as low, as possible, according to the sides they commenced by favoring. But it is not denied by a great majority, that there is a saving, however small.

Mr. Juland Danvers, the able Government Director of guaranteed Railways, and an advocate of the narrow gauge system, in the discussion

cites the Carnatic Railway, for which both broad and narrow gauge estimates were prepared, as an example in support of his theory. He says that there the narrow gauge is estimated at, £1,730 less per mile than the broad gauge. Most unfortunately for the cause, Mr Danvers advocates his figures will not bear examination; and, on looking closer at them, all the £730 will be found to disappear: still leaving it is true a good round saving of £1,000 per mile. Still it is to be deplored that the credit of a good cause should be damaged by the carelessness of its advocates in quoting figures, in this case more especially, as it is the only time in the whole discussion where an actual comparison of estimates for the broad and narrow gauge, made under precisely similar circumstances, is quoted.

Having taken a principal part in the preparation of both those estimates, the writer speaks from a knowledge of the facts of the case. The broad gauge estimate never advanced beyond the preliminary stage; while the other was estimated in detail, exactly the same location of line being adhered to. When those two estimates left the engineer's office, (speaking from memory,) no greater saving than £1,000 per mile was shown, if quite so much; but the metre gauge estimate was reduced in the Government Consulting Engineer's office, in some items contrary to the opinion of experienced railway engineers, so they will probably have to be replaced in practice; more especially by the substitution of wooden sleepers, in place of De Bergue's iron sleeper, which appeared in both the engineer's estimates.

The Oude and Rohilcund railway, the specimen in this country of the light broad gauge, has cost £9,000 per mile in round numbers; and who can say in face of the fact, that railways are being built in this country for very little more than half that sum that the broad gauge can be made for the same cost as the narrow.

Mr. E. W. Young at the close of his speech well sums up some of the most forcible arguments in favor of the narrow gauge and expresses his believe in suitability of the proposed railways to a country with an enervating climate, whose population is poor, and their wants small, who are physically weak, and unable to handle heavy weights.

Those who have ever had cause to make hasty repairs to a railway, with temporary bridges and ways, must fully appreciate the argument of the "handiness" of these small railways. In this country we are peculiarly

liable to the interruption of traffic from damage inflicted on the line by heavy floods. Material for repairs frequently is not to hand, and there may be insuperable difficulties in bringing up heavy appliances. But with the light loads to be carried, sleepers and rails will supply material for temporary bridges, capable of bearing the narrow gauge engines. The banks are narrow, and therefore more quickly made up, and will be capable of taking the light loads over them sooner than if a heavy engine has to be borne. This is not imaginary, but is the result of a sad experience on a narrow gauge railway much damaged by floods; and there is no doubt that had the rolling weight been heavier, the repairs could not have been effected, or even commenced as soon as they were, from the impossibility there existed for a time of transporting heavy or bulky material to the parts where it would have been required.

The narrow gauge is further most convenient for tramways either for locomotive or animal power. Many districts would be benefitted by being connected to the railway by a tramway, on which the lighter stock of the railway could be run, laid on the roads. Thus the trade of districts too poor as yet to maintain a railway would be fostered at a slight outlay, while the expense of road maintenance should be lessened. In time the tramway would give place to the railway, still on the road, the gradients being improved, and bridges built and strengthened where necessary; as a rule the road culverts would be found quite strong enough for the railway.

We have found many reasons demonstrating the superior suitability of the narrow gauge to India; and it is so, not to parts only, but to the whole; for nothing is so striking to a traveller in this country, as the sameness of scenery, and the little difference there is in the habits of the natives inhabiting different parts.

Now let us turn our attention to the "break of gauge." We have seen how there is an unbroken line of communication from south to north, connecting the principal ports and great centres of trade. We see from the map, that India is divided into several parts by this railway, of rather a triangular shape, bounded on two sides by the railway, and on the other by the sea. It is for these tracts of country, the area of each of which as big or bigger than France, that railways are required. Now, the metre gauge being adopted for these lines, how far will the break of gauge with the existing railways be prejudicial?

In discussing the question of the break of gauge at Madras, between

the Carnatic and Madras Railways, with a gentleman well informed on such subjects, it was said that goods were never shipped straight from the Railway, but first went to the godowns of a middle-man in the town of Madras, and he had no doubt that such would be the custom, even if the railways were of the same gauge, and there could be a through traffic. It is also not unreasonable to expect, that the inland trade of the country will converge towards a few large towns which are already connected with the coast and each other by a railway, and established as trading centres. The merchandize must necessarily there break bulk, and be stored in warehouses waiting the opportunity and convenience of the merchants for its distribution. Such is the custom in other parts of the world, and there can be no reason to suppose it would be otherwise in India, especially considering the large areas from which the goods are collected.

Again regarding each of these areas into which India is divided by the broad gauge railways, as separate countries, we see that each one has an essential to a mercantile country—a sea coast.

Trade with neighbouring countries by land is good, but limited; trade by sea with other countries far off is better and unlimited. Hence a railway to carry the produce of a country to the sea, and bring foreign imports to the interior, must be considered of more importance than a railway, giving only internal communication. The guaranteed railways now claim the privilege of carrying all the export and import trade of India between the coast and the interior, and hence the probable reason for the cry of "break of gauge."

To completely silence those who cry so lustily of the break of gauge, it is only necessary to see that the railway system of each of these countries is connected with the coast. And it is in the true interest of the trade of the country to do so, for the Indian produce is not of so costly a nature as to bear the cost of a lengthened inland transport, but precisely the reverse. If it is objected that there are no ports, it may be said that, if it pays to ship merchandize at Madras, or towns on the Coromandel or Malabar coasts, it will pay anywhere.

Examining the map again, we find that the whole south of India south of the Madras railway, is served by two lines, the Carnatic and Great Southern of India, which are to be amalgamated as the South of India Railway, and have a main line from Madras to Tuticorin. Is it reasonable to suppose that merchandize will pass the port of Madras and those south

of it; or that Tinnivelli cotton will go to the port of Bombay for shipment? Rather let us hope that a new harbour will be found at the south of the Peninsula. The proposed Carwar railway will serve all the Dharwar cotton plains, and have its port of Carwar. Hyderabad is connected with Bombay and Madras by a broad gauge railway, but it may be reasonably supposed that that town being the capital, will be the centre of trade of the Nizam's dominions. The Central Provinces have as yet only had one railway proposed for them, and that rather visionary, namely, an extension from Nagpore to Calcutta, if that is made, a connection is easily effected with the narrow gauge system of the Nizam's dominions. No one can say that at Nagpore there would be a break of gauge of the lightest consequence, as merchandize will always take the shortest route to the sea, and would be drawn one way from Nagpore to Bombay, and the other way to Calcutta. As this break would occur nearly half way between the ports, but little merchandize would require to pass through Nagpore. Lower Bengal, Orissa, and the northern provinces of the Madras Presidency have their own ports, and here the physical features of the country almost preclude the possibility of any large continuous railway system, or its junction with the existing broad gauge lines. In Rajpootana, a system of narrow gauge railways is in progress; and here occurs the only serious break of gauge in all India. At Ahmedabad or Deesa the Western Rajpootana railway, the connecting link of the Rajpootana system with the sea, will meet the Bombay and Baroda railway; and the utility of the Rajpootana lines will be seriously impaired by their connexion with Bombay being practically cut off.

The broad gauge line need not be extended; and should be strictly limited to what it is now, no branches even on that gauge being permitted. In fact the gauge must be altered, but it may be done gradually. As soon as ever the traffic would warrant a double narrow gauge line, or if in parts a double line is now wanted, let that line be laid on the narrow gauge, and not on the broad. As soon as ever the single narrow gauge reaches the whole length, let the other line be altered to the standard gauge. Of course the expense of working lines of different gauge side by side would be greater than if they were alike, and more stock would be required; but the excess here would be narrow gauge, and that afterwards would not be lost, but be spread over the remainder of the railways.

It is not a time to pay too great a regard to the private interests of

the guaranteed railways, or to suppose that their system is to be extended in the least; nor have they deserved indulgence at the hands of the Indian Government, and the time must be looked forward to, where Government shall be the absolute owner of all the lines in India. All these lines have been made with a view to a second line, and their works are of a necessary width. It is not probable that the double line will be wanted the whole length for many years, if at all, but it may happen a double line will be required between certain points.

The second line might in many instances be more profitably made, and worked in connection with the standard gauge systems of the surrounding country, as the very need of isolated portions of second line indicates that the traffic is local, and thus break of gauge would be avoided. By simple arrangements in working, and by, perhaps, some payment in compensation for the loss of part of the traffic, it could be provided that the Companies should not be losers by the arrangement. For military purposes, what is sufficient now will be sufficient hereafter; so the second line will not be needed for them.

The broad gauge lines must not be permitted to make branches on that gauge, or else the ends of the branches will become innumerable points of breaks of gauge. Indeed, it is one of the bad points of the broad gauge system, that it cannot serve the country properly, by making branches on account of the expense, and its strongest partisans advocate the construction of light railways or tramways to feed the great main lines.

We have seen now that the great evils anticipated from break of gauge are quite visionary. In only one place is there any inconvenience from it, and that can be remedied without much loss, as the broad gauge line is only about 300 miles long. This step will be essential to the welfare of the Rajpootana States, and when done, a new route will be opened from Bombay to Delhi and the north. On one gauge throughout, it will be a valuable auxiliary to the G. I. P. Railway in transporting troops to the north. The men with the lighter baggage could be conveyed to Delhi *via* Rajpootana; while the heavier munitions are conveyed by the broad gauge lines, arriving there a short time after the men.

It may be that the prospects of the companies are damaged by the change in the policy of Government; but they have still a very good chance of earning a fair revenue from the countries they traverse. The



broad gauge lines are of the first advantage strategically connecting as they do the North West frontier, the arsenals, and garrisons with the principal ports. This enables troops and stores to be forwarded on landing at a rapid pace to any part of India ; and it may well be doubted that, far from being the encumbrances to the country that many say they are, they are not rather a great protection. It is possible that we are all wrong in looking on these lines as commercial enterprises that should pay, but we should regard them as auxiliaries to the army capable of earning money in times of peace. We make military roads, why not military railways ?

But we have enough of such expensive works. The arsenals are well supplied by them with stores, which can always be distributed over the country by the other railways in case of the interior being disturbed, and the future railways are required to forward the arts of peace rather than the arts of war.

SIMLA,  
September 29th, 1873. }

C. H. G. J.

## No. CXI.

## ARTESIAN BORING AT UMBALLA.

[ *Vide* Plates XVI, XVII and XVIII ].

*Report by* MAJOR E. T. THACKERAY, R.E., *Exec. Engineer, Umballa Division, Military Works.*

## REPORT ON BORING OPERATIONS.

IN consequence of the scarcity of the supply of water from the wells in the Cantonments and City of Umballa, it was determined by the Government in 1869 that the experiment should be tried of sinking an Artesian boring in the Cantonments.

Opinions in favor of finding water at a depth of from 200 to 500 feet had been expressed by\* Dr. Oldham, Superintendent of the Geological Survey of India, to the Government of India, and the experiment was also advocated by H. B. Medlicott, Esq., Officiating Superintendent of the Geological Survey in India.

The engine and well-boring machinery were ordered from Messrs. Mather and Platt, of Manchester. The distinctive features of the machinery, are the mode of giving the percussive action to the boring tool, and the construction of the tool or boring head, and of the shell-pump for cleaning out the hole after the action of the boring head. These are described at length with illustrations, page 106, *et seq.*, in the Extra Number of the "Professional Papers of Indian Engineering," 1st Series, April 1870.

The soil at the bottom of the bore is loosened by repeatedly letting fall (from a height of about 2 feet) cutting tools suspended at the end of a flat-rope. After a certain depth has been loosened in this way, the cutting tools are brought up, and water is put down the bore (if necessary), and the material, of whatever description, is brought up in a suction-pump about 4 feet long let down by the same flat-rope. The pump is called a slush-pump.

\* *Vide* page 122, *et seq.*

In a firm soil a hole could be bored in this way (if sufficient water was available) to a great depth without tubing.

In Umballa the soil hitherto met has consisted of alternate layers of clay and sand at close intervals, and all the sand strata are more or less water-bearing.

In boring here generally the sand-beds have been shut out as soon as they have been bored through, by pressing the tube into the top of the underlying clay strata, and the tubing has generally been kept going, while the boring and pumping are going on, so that the bottom of the tube and the bottom of the hole have been kept nearly on the same level.

But in boring through clay strata, the boring tools have been allowed to be some depth below the bottom of the tube.

By this arrangement the hole bored is somewhat larger than the external diameter of the tube (owing to free play of the tools below). This is of the greatest advantage in stiff clay soils, because the resistance in getting down the tubing becomes so much reduced.

The tubing is pressed down by means of screw-jacks adjusted to "clams" firmly fixed to it, occasionally assisted by gentle tapping on a wooden block fitted to the top of the tubing.

These screw-jacks work against seams let into the sides of an ordinary masonry well about 30 feet deep, within which the boring was commenced.

The machine was erected, and the boring operations commenced on the 1st November, 1869, by Mr. Herrop, the Engineer in charge of the work; and the boring was continued daily, Sundays excepted, until the 16th April, 1870.

When the bore had reached less than half its final depth, water was found, and rose in the tube to a level of 35 feet below the surface of the ground. The supply was, however, very scanty, and could be pumped out in a few hours.

In the hope of reaching a more useful water-bed at a greater depth, it was resolved to push on and go lower.

On the 16th April, 1870, a depth of 381 feet was reached, and it was found necessary to discontinue boring with tubes of  $9\frac{1}{4}$  inches in diameter: a pressure of 64 tons on the screw-jacks being insufficient to force the tubes to a further depth.

The 7-inch tubes were then lowered and forced down to a depth of 455 feet; but on the 13th August, 1870, the lower tubes broke at the bottom

joint 9 feet from the bottom of the bore, a pressure of 80 tons having been exerted on the screw-jacks.

Work was then stopped; and Mr. Herrop proceeded to Subzilkote under orders of Government, where he was successfully employed in sinking an artesian well.

The Umballa boring was not re-commenced until the 23rd May, 1871; and in that month a detachment of Sappers, consisting of a Naik and five Sepoys, arrived from Roorkee for the purpose of being employed on the boring.

The 5-inch tubes were now lowered and forced down inside the 7-inch tubes to a depth of 552 feet. At this depth it was found that the tubes had become bent, and it was necessary to bring up the whole of the 5-inch tubes. This was completed on the 22nd July, 1871.

On again lowering the 5-inch tubes, it was found that the lowest of the 7-inch tubes had become detached from the others, and was obstructing the hole at a depth of 456 feet.

Efforts were made to straighten the tube with a large cigar-shaped iron-bar, but this was not successful.

The 5-inch tubes were then again brought up, and attempts made to cut up the broken 7-inch tube. In doing this, the 7-inch broken pipe was driven into the sand and clay, and the whole of the 7-inch tubes were forced down after it.

On again lowering the 5-inch tubes on the 26th August, 1871, it was found that the broken 7-inch tube still obstructed the boring.

On the 2nd September, 1871, the broken tube was cut up by means of a heavy bar, and several pieces of the broken tubes were brought up, and on the 9th September the obstacle was sufficiently got out of the way to allow of the further descent of the 5-inch tubes.

During the week ending 23rd September, 1871, the flat rope broke twice, and there was considerable difficulty in bringing up the pump which had become covered up in the sand and clay. The rope was brought up in six pieces, the last portion with the bar attached being brought up on the 23rd September.

The rope being now so much damaged as to be unfit for use, operations were now resumed with boring rods.

At a depth of 526 feet it was found impossible to pass the pump down the 5-inch tubes, owing to their having become bent from the pressure. A small pump of 3 inches diameter was then attached to four 3-inch

pipes, and the whole lowered down within the 5-inch tubes; but the pump and 3-inch pipes stuck fast in the joint of the 5-inch pipes. The pump, was however extricated on the 11th September, and it was then determined as a last recourse to lower the 3-inch pipes.

Boring was continued by means of boring rods and the 3-inch tubes, and a depth of 638 feet was reached on the 16th December, 1871, when the new flat 3-inch rope arrived from Calcutta.

The boring then proceeded more rapidly to a depth of 660 feet, when the twenty-fourth 3-inch tube from the top of the well broke at the flange under a pressure of 40 tons.

The upper 24-inch tubes were then brought up, but the boring was obstructed at the point of fracture, and Mr. Herrop commenced drilling through the obstruction.

The first obstruction was drilled through, but another was found at a depth of 323 feet.

This was also passed, and a third obstruction met with at 580 feet.

These obstructions were probably caused by portions of the fractured tube having fallen down the hole.

Another obstruction was met with at a depth of 646 feet, but this was got through, and the 3-inch tubes were lowered to a depth of 655 feet.

Boring was continued to a further depth of 41 feet without tubing, but the sides then began to fall in, and it was necessary to discontinue work.

Several of the 3-inch and 5-inch tubes have been brought up in accordance with the instructions received from Government, but the boring rods to which the implements necessary to bring up the pipes have to be attached are only  $\frac{3}{4}$ -inch in thickness, and in consequence have broken, and remain in the hole.

It will be necessary to procure a length of 750 feet of rods of not less than  $1\frac{1}{4}$  inches in thickness before the remaining pipes can be brought up.

Specimens of the clay met with at depths of 585, 593 and 601 feet were forwarded to the Geological Survey Office, Calcutta, for analysis, and the results are as follows:—

	No. 1. Depth 585 ft.	No. 2. Depth 593 ft.	No. 3. Depth 601 ft.
Water and organic matter, ...	8	1.2	1.5
Insoluble sand and clay, ...	92.8	8.8	82.1
Oxides of iron and alumina, ...	5.2	6.4	8.
Lime carbonate, ...	1.2	4.4	8.4
	100	100	100

The specimens, as will be seen from the analysis, contained very little organic matter, and are very silicious, the residue insoluble in acids, being almost entirely silica.

It is worthy of remark that at the depths of 600 to 700 feet, very little sand was met with : a stratum of 5 feet of coarse-grained sand only being found at a depth of 683 feet.

Should it again be proposed by Government to sink another boring, the experience gained would seem to show that a larger machine should be employed, and that the diameter of the upper tubes should not be less than 2 feet. It might then be possible to bore to a depth of 1,400 or 1,500 feet.

*Nature of soil met with in boring the Artesian well at Umballa.*

		Feet.			
Clay,	Total depth, of,	283 $\frac{1}{2}$	Number of separate strata.	47	
Sand,	do., ...	186 $\frac{1}{2}$	"	" ...	39
Sand and Clay,	do., ...	54 $\frac{1}{2}$	"	" ...	13
Kunkur Bearing,	do., ...	93	"	" ...	22
Boulder do.,	do., ...	83	"	" ...	16
	Total,	...			186

METHOD OF WITHDRAWING THE TUBES.

The pipes used in the Artesian well boring were of four sizes, viz., 9 $\frac{1}{4}$ -inch, 7-inch, 5-inch, and 3-inch diameter, and were each 9 feet in length.

The pipes of the same diameter screwed on to one another by means of screws and flanges, and were sunk into the boring by means of a Mather and Platt's Steam Artesian Well Boring Engine.

The diameter of the boring at the top was 9 $\frac{1}{4}$  inches, and owing to various obstructions—in most instances caused by bending or fracture of the tubes—pipes of a less diameter than those with which the boring was commenced had to be used. These were lowered inside the larger tubes, so that the diameters of the tubes were gradually contracted, at first owing to an obstruction at a depth of 381 feet being reduced to 7 inches; then at a depth of 456 feet to 5 inches; and, lastly, at a depth of 525 feet to 3 inches.

In consequence of the bending and fracture of the 3-inch pipes at a depth of 513 feet from the surface of the ground, it was found impossible to sink pipes of so small diameter to a greater depth than 655 feet, and

although the boring was continued with rods and boring tools to a further depth of 46 feet, making a total depth of 701 feet from the surface, the clay at that depth not being supported by tubes began to fall in, and the boring had to be abandoned; *Plate XVI., Fig. 1*, showing the condition of the boring, and the numbers and dimensions of the tubes left in the bore at the time of the boring operations being closed.

The following is a short description of the means adopted for raising the tubes from the boring:—

An implement called a fish-head, with steel cutters, (*Plate XVII., Fig. 2*), was attached by a screw to iron rods, which were lowered to a depth of 513 feet, at which depth the 3-inch tubes were fractured. The iron rods—which were also used during the boring work as boring rods—were each  $\frac{3}{4}$  of an inch square, and screwed on to one another by means of nuts and screws 3 inches long. The upper end of the rods was attached by clamps to four screw-jacks, two above and two below, (*Plate XVII., Fig. 3*). The screw jacks were turned by eight men, two men to each jack, and on pressure being applied upwards, the steel cutters, which turn on a pivot in the centre of the fish-head which is attached to the lower end of the rods, open outwards on encountering the jagged iron caused by the fracture of the 3-inch tubes and cut through the pipes at the junction of the screw and flange. The vertical pressure on the rods being still applied upwards by means of the screw-jacks, the upper tubes are separated from the lower ones at the point of fracture.

The tubes have now to be raised, and to effect this the screw jacks are removed, and a strong iron ring (*Plate XVII., Fig. 5*), is screwed on to the top of the upper rod, and is attached by an iron hook and shackle to the end of the flat rope, which winds round the drum of the boring engine. Steam being now admitted into the cylinder, the flat rope is wound round the drum and raises the iron rods, with the fish-head still holding in the under edge of the 3-inch pipes which have been separated from those below them.

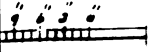
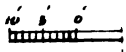
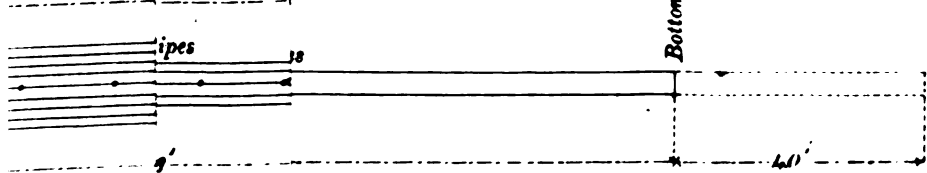
As each pipe arrives at the top of the boring it is unscrewed from the pipe next below it, steam pressure being still applied to prevent the rods and pipes from falling back into the boring.

Strong iron clamps (*Plate XVII., Fig. 4*) are then fixed round the upper part of the second tube. The clamps rest upon two beams of sál wood, of 14 x 10 inches scantling, which are let into the masonry which

Arts  
ing the leng

Bottom of 8-inch tubes.

Bottom of 8-inch tubes.







lines the upper part of the well. The second rod from the top is also secured by clamps, (*Plate XVII., Figs. 5 and 6*), which are also used for raising the rods, as before described, and which prevents the rods from falling back within the pipes.

The upper rod is now unshackled from the winding rope, and unscrewed from the second rod, and the upper tube and the upper rod are removed from the boring.

The ring is now screwed on to the nut of the second—now the upper rod—and is hooked on to the winding rope. Steam pressure is again applied, until the winding rope is taut and sustains the weight of the rods and pipes, and the clamps that secure the rods and pipes are unfastened. On the rope being wound round the drum, the second pipe is raised in the same manner as the first, the fish-head still holding at the bottom of the tubes; and this process is repeated until all the pipes are brought up.

Several pipes of 5-inch diameter were brought up in a similar manner, the diameter of the fish-head being increased to fit the larger tubes.

E. T. T.

---

*Opinion of T. OLDHAM, ESQ., L.L.D., Supdt. Geological Survey.*

7th August, 1872.

I beg to acknowledge receipt of your letter No. 927 B—M, dated 2nd instant, and in reply to state that the grounds of hope for success in prosecuting borings for Artesian wells near Umballa are exactly those which have been already fully set forth in this Office letter, of which a copy is annexed\*.

There is known to be, and must be, a very great absorption of water along the base of the hill region, of which there is a very limited or no re-appearance at the surface further south, and which therefore, it is most reasonable to suppose, must be found under ground.

The existing boring cannot be successfully carried further down; it was commenced with too small a bore, but others ought, I conceive, to be tried, and I would recommend boring at least to the sea level if success do not sooner reward the trial.

T. O.

---

\* *Copy of letter (above referred to). BY H. B. MEDLICOTT, ESQ., dated 27th May, 1867.*

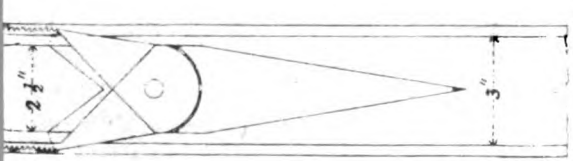
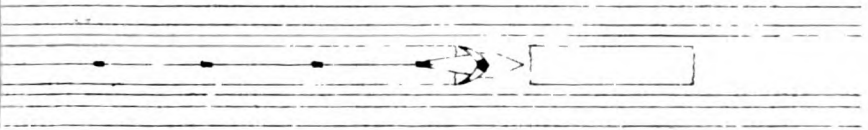
I have the honor to acknowledge your letter, No. 853 of 14th May,

1867, addressed to Dr. Oldham asking for an opinion upon the prospects of an Artesian boring at Umballa. Pending Dr. Oldham's return from Europe in November next, I would submit the following remarks on this interesting and important subject.

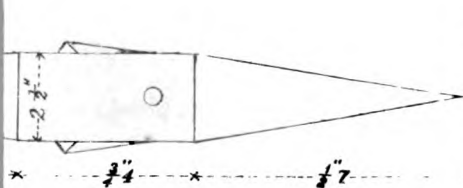
In Volume III. of the Memoirs of the Geological Survey of India, at page 182 of my paper descriptive of a portion of the North-Western Himalayas, I have briefly described the condition of formation of the Gangetic plains with reference to the prospects of artesian borings. Upon general considerations more or less matter of fact or matter of inference or conjecture, I then expressed an opinion decidedly in favor of such experiments. With reference to the definite project now emanating from the Government of the Punjab, I have endeavoured to supplement the independent opinion formerly arrived at by reference to numerous authorities and analogous examples, and I am happy to state that these have proved entirely satisfactory and encouraging. I can do no better than to cite a number of these cases; they are so untechnical and intelligible, that I hope they may be sufficient to give the Government much confidence in sanctioning the outlay, and in ordering the immediate execution of the project.

(a.)—At Conselice, in the Province of Ferrara, on the plains of the Po, which are formed by an unknown thickness of alluvial clays, sands and gravels, an artesian boring was made on account of the deficient supply, and the saline qualities of the surface waters (*see* Bull. Soc. Géol. de France, Vol. XIV., p. 102, 1856-57). The locality is 13 miles distant from the flanks of the Appenines, along which the plains' deposits rest against, and upon, disturbed strata of upper tertiary age. Water was found at 160 feet in a bed of gravel, and rose to 6 feet above the surface. The water bed is in the superficial deposits; the underlying formation was not reached. The surface beds are not stated, but I infer from the description that Conselice is but little above the sea level (it was formerly on the coast, though now 22 miles inland), and that the water bed is here far below the sea level, and was probably deposited under salt waters. The sweet water now drawn from it is, no doubt, derived by infiltration from the higher slopes at the base of the mountains. Success was confidently looked for, based upon arguments such as I have applied to the plains of Upper India.

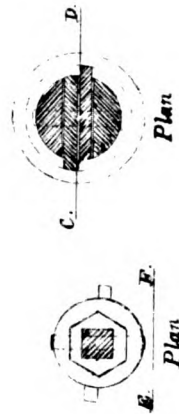
The numerous artesian wells sunk in the Eastern Sahara present strati-



Section on C.D.



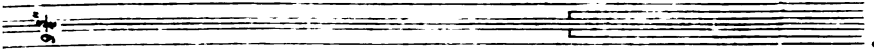
Elevation on E F



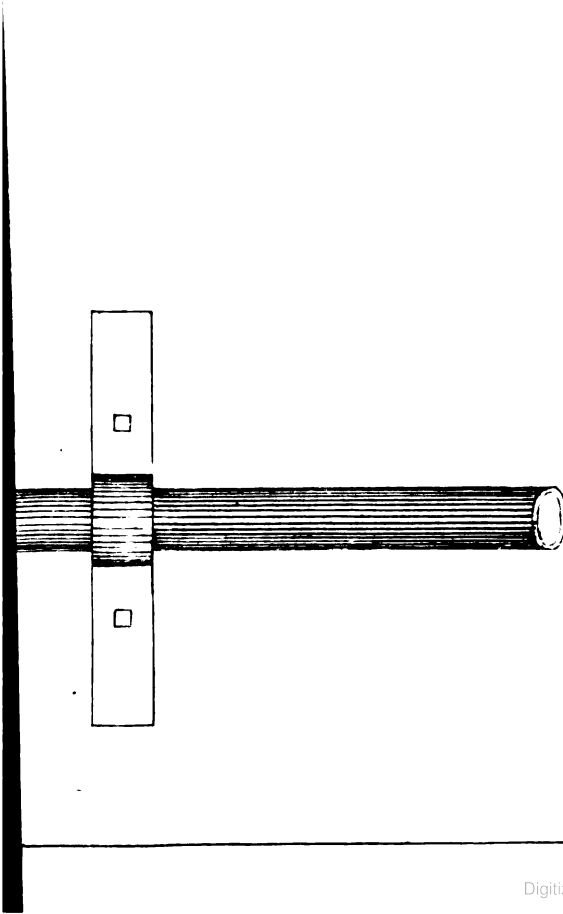
Scale, 1 foot to 2 1/4 inches







Scale, 4 feet to 1 inch.



Scale, 1 foot to 1 inch.



graphical conditions essentially like those of the plains of India, great deposits of coarse and fine detritus adjoining and overlying disturbed and denuded tertiary strata. The composition and the overlapping arrangement of the beds indicate their mode of deposition by diluvial transportation from the neighbouring mountains. The exact thickness of these deposits is not known; but the artesian water lies in them apparently in the coarser materials, which, as a rule, predominate at the base of the section. The chief features of some of these borings are worth recording here. The work was all done by detachments of French soldiers, the temperature being sometimes at 114°. (*See* Bull. Géol. de France, Vol. XIV., p. 615, 1856-57.)

(b).—At Oum el Thiour, elevation 115 feet, about 50 miles from the edge of the plains, where the elevation is 360, a first spring was reached at 100 feet in quicksand, and rose within 8 feet of the surface; a second spring at 138 feet in quicksand, rose to within 3 feet of the surface; the first jet rose from 178 feet in quicksand, and gave 4½ gallons per minute, a second jet rose from 224 feet in hard sand with kunkur, and gave two gallons per minute; a third jet rose from 264 feet in clear sand, and gave 33 gallons per minute. The deficiency of this spring was accounted for by the proximity of a deep depression of the surface. The chances were considered unfavorable.

(c).—At Famerna, elevation 128 feet, a jet rose from 198 feet in fine sand, giving 990 gallons per minute. The bore was sunk in 89 days.

(d).—At Sidi-Rached, elevation 142 feet, a jet rose from 178 feet in conglomerate, giving 990 gallons per minute. This is 60 miles from the supposed source of supply at foot of hills.

(e).—At Tamelath, a first boring, 198 feet elevation, and a depth of 148 feet in gravel, gave 9 gallons per minute. A second boring at 191 feet elevation, and a depth of 191 feet in conglomerate, gave 33 gallons per minute. These two wells were especially instructive, because of the total want of similarity in the sections of the beds passed through, although the positions were only 120 yards apart, thus showing that success is compatible with great irregularity in the nature of the strata.

(f).—At Oned el Aleng on the plain of Metidja, which slopes towards the Mediterranean from the north base of the Little Atlas, two borings were made in the deep diluvial deposits. The first boring at an elevation of 178 feet from a depth of 856 in gravel, delivered 260 gallons per



minute at 6 feet below the surface. *Annales des Mines*, 6th Sec., Vol. IX., p. 333.

(g).—The second well, four miles north of the first and 100 feet lower, from a depth of 237 feet in gravel, gave a discharge of from 660 to 780 gallons per minute; the former quantity equals nearly a million gallons a day. The first of these wells was sunk in 51 days of 20 hours; the second in 16 days. (*See Annales des Mines*, 6th Sec., Vol. IX., p. 333). In this case also the stratigraphical conditions are similar to those of the Indian plains.

Some particulars of cost and construction may be useful for comparison. I may take the well (f.)

						Ra.	Ra.
Freight and tools,	...	...	...	...	...	1,090	
Labor and supervision,	...	...	...	...	...	1,174	
Contingencies,	...	...	...	...	...	181	2,445
						<hr/>	
132 feet of 8-25 inch tubes,	...	...	...	...	...	350	
224 " 10-62 "	...	...	...	...	...	765	
158 " 11-88 "	...	...	...	...	...	600	1,715
						<hr/>	<hr/>
					Total,	...	4,160

The labor was done by military convicts, receiving 10 annas per day of 10 hours. The work was completed in 51 days of 20 hours.

The depth of this boring is a sixth more than that estimated for by Mr. Purdon; yet the cost is little more than a fourth; the time of execution also was about a sixth. The ground to be cut through being about identical in the two cases, the discrepancies in time and cost seem vastly greater than can reasonably be accounted for by the different circumstances of Algiers and India. The engine and the well are extra items in Mr. Purdon's estimate, for which the necessity or advantage is not apparent.

The comparison of all the knowable conditions in the cases I have enumerated with those at Umballa and other such positions on the plains of Upper India, seem altogether in favor of the latter: notably the condition of rainfall along the region of absorption. Although, as I have pointed out, there are assignable possibilities of failure, the apparent chances of success are far greater than can generally be counted upon in undertakings of this nature.

Viewing the very extensive and numerous regions of India, more

especially in the North West, in which the want of water is more or less felt, and where conditions obtain apparently and, as far as at present known, analagous to those which have been just described; considering, too, the trifling outlay of time and money requisite under *good management* to obtain very considerable supplies of water by artesian borings, it would surely be well worthy of Government to institute a series of experiments on a really efficient scale. For this it would be necessary to procure from Europe a set of the most improved tools, and one or more trained workmen.

H. B. M.

---

---

 No. CXII.
 

---

 REVIEW OF PAPER (No. CVII.)\*  
 ON WELL FOUNDATIONS AND WELL-SINKING.
 

---

*Reviewed by* CAPT. A. CUNNINGHAM, R.E., *Hony. Fel. of King's Coll., Lond.*

---

[The References are to Paper No. CVII. in Professional Papers on Indian Engineering, Second Series, Vol. III, No 11.]

---

THE Paper under review (No. CVII.) contains a short discussion of the principles—some theoretical, some practical—of calculation of Stability of Well foundations, followed by some Tables of the results of the author's calculations of Stability of the Piers on six large Bridges on the Oudh and Rohilkhand Railway.

The most important results are undoubtedly those in the "General Table," the figures in which show the *apparently satisfactory* result, that in five of the Bridges there is a considerable excess of Stability in the Piers, and that in one Bridge (over the Rámangá) the Stability is doubtful.

As these figures have been published for the information of the profession at large, and with the author's expressed "hope of inducing others to give their contributions" to the discussion of the subject, the writer deems it a public duty to show that at least two extraordinary errors appear to run through the calculations, of a character which renders the numerical results *wholly unmeaning*.

Four of the Tables, pages 79, 80, 82, and the large "General Table,"

\* By Ed. Byrne, Esq., M.I.C.E., Ex. Engr., P. W. D.

show details and abstracts of calculation of quantities, there styled "Resisting Power," "Overturning Power," "Overturning Effect," "Impact," "Excess of Resisting over Overturning Power," "Shock."

The term "Power" has been unfortunately chosen. In Table, page 79, column 5, it is explained to be "product of weight and leverage," and in Table, page 80, column 6 to be "product of pressure  $\times$  by surface  $\times$  by leverage." By this term "Power" is therefore really *meant* (what is usually styled) "Moment" thus—

"Resisting Power" of page 79, is equivalent to "Moment of Stability."

"Overturning Power" of page 80, is equivalent to "Moment of Instability."

A little examination of Table, page 82, and of the large "General Table," will show that by the word "Power" is there generally *meant* "Moment."

Such Statical Moments are of course measurable only in (statical) moment-units, *e.g.*, in (statical) foot-pounds (the weights having been calculated in pounds, and the leverages in feet), or in foot-tons, &c.

This "Power" is however *described* as estimated in *pounds* and in *tons*, see Table, page 79, column 5, and Table, page 82, lines B, C, G.

In the Table, page 80, and in the large "General Table," the *unit* of measure is not printed, but internal evidence shows that the figures are *intended* to be reckoned as *pounds*.

Again it is well known that "Shock" can only be measured in compound units of "work," or "energy," *e.g.* :—

1°. In *direct* effect by *vis viva*-units, *e.g.* (dynamical) "foot-pounds."

2°. In *overturning* effect by *vis viva*-moment-units, *e.g.* (dynamical) foot-foot-pounds.

In the Table, page 82, lines J, K, "Shock" (apparently of the latter sort) is described as estimated in *maunds* and also in *tons*.

Such mistakes, though misleading, would not of themselves vitiate the numerical result, but they often lead to much more serious errors; at least two such errors appear to run through the calculations under review, of a character rendering the numerical work wholly illusory.

The figures, &c., on page 79, together with the text, show that the term "Power" has been used both for "Force" (its legitimate meaning)—which is measurable in pounds—and for "moment"—which is measurable in foot-pounds, and that these two (totally unlike) quantities have been actually *added* together, and the result styled "Total Resisting Power."

It need hardly be remarked that the result of adding the figures which ex-

press the magnitudes of two such totally unlike quantities has *no physical meaning*.

This error is carried forward under columns headed "Cawnpore Ganges Bridge," into Table, page 82, line G, and "General Table," and from internal evidence it seems probable that this error runs *right through both Tables*.

Again, the figures on page 82, lines D, H, leave little doubt that in order to compare the results of impact with the Statical Forces, two utterly unlike quantities, viz., a statical Moment—measurable in statical foot-pounds and a *vis viva*-moment—measurable in dynamic (kinetic) foot-foot-pounds,—have been equated.

It need hardly be remarked that the result of equating two such utterly unlike quantities has *no physical meaning whatever*.

*Proof of the above statements.*

i. In para. 9 of the text, it is stated that "tenacity has been presumed to apply to one-half only of the plane of fracture."

Now, in the Cawnpore Ganges Bridge—see Table, page 79—the "plane of fracture" is the cross section of "one 18 feet and one 10 feet well."

$$\begin{aligned} \therefore \text{Area of half of } \left. \begin{array}{l} \text{plane of fracture} \end{array} \right\} &= \frac{1}{2} \left\{ \pi \cdot \left(\frac{18}{2}\right)^2 + \pi \cdot \left(\frac{10}{2}\right)^2 \right\} = 58 \pi \text{ sq. ft.} \\ &= 144 \times 58 \pi = 28975 \text{ sq. in.} \end{aligned}$$

Hence taking tenacity of mortar at 20 lbs., 50 lbs., and 800 lbs., (as in the Table, page 79), there result

"Corresponding Resisting Power" = 479,500 lbs.; 1,198,7500 lbs.; 7,192,500 lbs. These are the very figures in the Table, page 79; it will be observed that they are all three *Forces* (Tensions) and measured in pounds, and it will be seen in the Table that they are each separately *added* to the quantity styled

"Power due to weight and leverage" = 17,695,808,

which as before explained is *really* a "moment," and measured in foot-pounds. The result has been styled "Total Resisting Power."

ii. The Table, page 82, styled "Comparative Table of Floating Masses" professes to give in lines D, E, H, I, J, K, the weights of bodies which would produce by their "Impact" an overturning effect equivalent to that of certain of the Statical Forces in play.

Now, this is really a Problem of considerable difficulty: Problems of Impact are generally treated by equating the various actual visible "strains" which a structure suffers under impact and under (statical) pressure; but this is always a Problem of some complexity, and for its numerical solution requires that the co-efficients of elasticity of the material corresponding to each of the strains should be known: they are, however, known only for certain materials, and are *not known for brick-work* (the material under consideration).

Neither the Text nor the Table itself explain how the numerical results in lines D, E, H, I, J, K were arrived at, but there can be little doubt (from the close agreement of the numerical results) that the process used was the following:—

The Problem is—To find the weight  $W$  of a body which moving with a given velocity ( $v$ ) shall produce with a given leverage ( $h$ ) an equal "overturning effect" to a given (statical) moment ( $M$ ).

Whatever may have been the actual formula used, it is probable that the following (an impossible equation)

$$W \cdot \frac{v^2}{g} \cdot h = M, \text{ whence } W = \frac{Mg}{v^2 h}$$

was used: for it will be found (on actual trial) to give the whole of the numerical results in lines D, E, H, I, J, K, under column headed "Cawnpore Ganges Bridge," in the Table, page 82. The data are

$v = 15$  feet per second. (See Table, page 80).

$h = 54.6$  ft. with scour 85.4 ft. deep } these may be deduced from page 79.  
 $h = 70.6$  ft. with scour 51.4 ft. deep }

$M$  is given in lines B, C, G, Table, page 82.

Take one example,  $M = 2,082,990$ , line B, page 82.

$$\therefore W = \frac{2082990 \times 32.19}{15 \times 15 \times 54.6} = 5460 \text{ lbs.}$$

This is the very result printed in line D, page 82. The other results lines D, E, H, I, J, K, can be obtained in same way.

From the strict agreement of the numerical results of this formula with *all* those stated there can be little doubt that this formula, or some modification of it, was that actually used. It is easy to see that it is a *false* equation, thus  $W \cdot \frac{v^2}{g}$  is twice the *vis viva* or "accumulated work," and measurable in work-units, *e. g.*, in (dynamical) foot-pounds, and  $h$  is a length, so that  $W \cdot \frac{v^2}{g} \cdot h$  contains the compound unit foot-foot-pounds (dynamical), whereas  $M$  being a statical moment is measured in (statical) foot-pounds. The equation of these (totally unlike) quantities is simply impossible.

With these two errors alone, the whole of the numerical results of these Tables must be viewed as literally "unmeaning." It is possible that the author may be able to show that the close numerical agreements on which the proof of these statements rests are mere accidental numerical co-incidences; if the author is able to substantiate this, and to show that these errors do not exist in the calculations, no one will be better pleased than the reviewer, or more ready to own himself hasty in trusting to mere numerical co-incidences.

The theory of Well-foundations has been recently fully treated of in No. LXXXIII.\* of these Papers. It seems unnecessary to do more than notice certain points of principle in the Paper under review, which (the reviewer considers) cannot be upheld.

i. The little difficulty alluded to in para. 1. of the paper under Review, is very fully explained in Arts. 45, 46 of Paper LXXXIII. It is true, of course that the lower the "centre of Moments" is taken, the more the

\* by the present writer.

“Moment of Instability” is increased, but the “Moment of Stability” is always thereby *increased to at least an equal degree*, so that in fact (provided *all* Resisting Forces be included) it matters not where the “centre of Moments” is taken.

ii. A Pier may fail by tilting over *as a whole*, or by snapping across. These are *distinct* Problems (of Stability and Transverse Strength) requiring distinct examination.

In the Paper under review they are not separated. They will be found separately treated in Paper LXXXIII.

iii. The question of effect of Friction on the sides of a Well is one of the most difficult: it is treated of in Art. 21 of Paper LXXXIII., but the present state of *experimental* knowledge of subsoil does not admit of a thorough treatment. It seems (to the reviewer) most difficult to conceive the suggestion (in para. 32 of the Paper under review) that “*friction may act as a large counteracting force to that of buoyancy.*” This involves the idea that Friction may set vertically *downwards* round the sides of a Well. This is contrary to the fundamental principle of statical friction, viz., that Friction is developed only *contrary to incipient motion*: until therefore there be an *actual tendency* of a Well to *rise* vertically from its position, how can there be any *downward* friction?

A. C.

## No. CXIII.

## REDUCTION OF BAROMETRIC READINGS AT HIGH STATIONS TO SEA LEVEL.

BY CAPT. ALLAN CUNNINGHAM, R.E., *Hony. Fellow of King's Coll., Lond.*

*Remarks on existing Tables.*—The Smithsonian Hypsometrical Tables purport to be a complete collection of the most useful Tables for Meteorological work. Only two, however, of the Barometrical Tables of this extensive collection are suited to the problem in hand, (of reducing Barometric readings at *high* stations to sea level), viz., those of Gauss and Dippe, at pages 54 and 60, but they both have two grave inconveniences for the *frequent* use of English meteorologists, viz. :—

- (1). The measure of length employed is the old French toise.
- (2). The temperatures must be expressed in degrees on Reaumur's scale.

2. *New Tables proposed.*—New Tables have been calculated by the author to facilitate the reduction in question of English Meteorological observations. It is considered desirable to present an explanation of their construction, and a discussion of their sufficient accuracy.

3. *Relation between height and pressure of air.*—The state of the atmosphere is one of such extreme variability, and the laws of this variation are at present so imperfectly known, that the relation between the actual height of the barometer at two places, and the difference in elevation of the places can at present be only approximately (somewhat roughly) expressed: the true relation is most probably a very complex one.

Two formulæ have been proposed by the eminent mathematicians



Laplace and Bessel, which express this relation, more or less approximately, and are known by their names.

In Laplace's formula the following elements of variation are allowed for :—

- 1°. Variation in force of gravity in different latitudes.
- 2°. Variation in force of gravity at different altitudes.
- 3°. Difference of temperature of the mercury at the two stations.
- 4°. Variation of temperature of the air between the two stations.

In Bessel's formula the following elements of variation are allowed for :—

- 1°, 2°, 3°, 4° as in Laplace's formula.
- 5°. Variation of moisture of the air between the two stations.

4. *Defects in the formulæ.*—Both these formulæ labor under the following\* defects :—

- 1°. The investigation assumes that the air between the two places is in a *state of relative equilibrium*, so that the investigation is made according to the laws of Hydrostatics.
- 2°. The effect of the rotation of the earth is not considered.
- 3°. The variation in force of gravity due to local attraction of mountain mass is not considered.
- 4°. The allowance for variation of temperature of the air between the two stations is only roughly approximate.

With respect to the above :—

- 1°. It is obvious that the "relative equilibrium" supposed is frequently *non-existent*, particularly when the stations are *far removed* from one another.
- 2°, 3°. The effects of these two causes on the variation of pressure of the air are probably very small.
- 4°. The law of variation of the temperature with the height is even now unknown. As to the error due to imperfect estimation of this variation, Laplace states† in his investigation that, in consequence of the difference of altitude of the two places being always small compared with the whole height of the atmosphere, *almost any* (assumed) law which makes the *variation of temperature nearly in arithmetical progression*, and *agrees with the actual temperatures at the two stations*, is *admissible*.

The law of variation which he assumed (for convenience of calculation) amounts in the *resultant effect* to assuming the air between the two stations of a *uniform temperature equal to the arithmetical mean* of the temperatures of the two stations.

Laplace's formula has also the additional defect :—

- 5°. No allowance is made for *variation* of moisture in the air between the two stations.

\* Pointed out to me by J. Elliott, Esq., M.A., Professor of Mathematics, Muir College, Allahabad.  
 † *Mécanique Céleste*, Bowditch's Translation, Vol. IV., page 566.

5. In proposing new Tables for general use of Meteorologists, it has been judged advisable by the author to expose the defects in the above formulæ which are (it is believed) the only ones available for the purpose.

As to the confidence which may be placed in the results of using these formulæ it may be observed that the numerical values of the "constants" therein were corrected from the theoretical values which they should have had under the imperfect hypotheses (*see* list of "Defects") used in constructing the formulæ, in such a manner that the heights *calculated from the formulæ* might agree as nearly as possible with a series of heights calculated from a long and careful series of geodetic operations. The consequence is that the numerical values of the constants, as generally used, do *in themselves* contain an approximate correction for the error (especially that due to omission of effect of rotation of the earth) that would otherwise have resulted from those imperfect hypotheses.

6. *Bessel's formula*.—With respect to this, it seems sufficient to say that it is by no means\* certain that it yields results in any way better than Laplace's formula; as it is much more complex than the latter there seems to be no particular advantage in using it.

7. *Laplace's formula*.—The original investigation is contained in the *Mécanique Céleste*, Tome IV., page 292, also in Bowditch's translation of the same Vol. IV., page 565. There is a complete investigation with the improvement of a correction for effect of local attraction in Besant's "Treatise on Hydromechanics," Chap. V. There is also a fairly complete and concise investigation in Cape's *Course of Mathematics*, Vol. II., Art. 458, an easily accessible work; and in Spon's *Dictionary of Engineering*, 1869,—Art. Barometer.

8. *General accuracy of Laplace's formula*.—In consequence of the corrections to the numerical value of the "constants" alluded to in Art. 5, this formula does, *under suitable limitations*, give very good *average* results.

Guyot says (at page 34 of the Smithsonian Hypsometrical Tables)—

"The close agreement of the determinations furnished by Laplace's formula, in barometrical measurements carefully conducted, made in favorable circumstances,

\* Smyth and Thuiller's *Manual of Surveying in India*, 1855, page 426. On the use of the Barometer, by Major R. S. Williamson, U. S. Engineers, 1868, page 227. Smithsonian Hypsometrical Tables by A. Guyot, 1869, page 33.

and during the warm season, with those obtained from repeated trigonometrical observations, or by the spirit level, strongly testifies in favor of its general correctness."

After quoting several striking instances of this close agreement, he says—

"These figures show conclusively, that, when the errors which may arise from the great variability of the data furnished by the instruments have been removed by a repetition, in various states of the atmosphere, and by a proper combination of simultaneous observations at stations not too far distant from each other, those which remain, and may be attributed to the formula cannot be considerable. But on the other hand, we have no right to expect such results from single observations, taken perhaps in unsettled weather, without paying any regard to the time of the day at which they were made, to the distance or the non-simultaneity of the corresponding observations, or to other unfavorable circumstances. It is too well known, that in such cases large errors may, and do actually, occur; but for these the formula ought not to be held responsible."

9. *Laplace's formula simplified.*—The complete formula is (in the writer's opinion) unnecessarily complex for the purposes of the present problem. It will presently be shown (Art. 11) that, *in actual use* of this formula *for the present purpose*, one of the data (the temperature at sea level) will in most cases be so *inaccurately* determined, that great accuracy in the small quantities in the formula is quite unnecessary, and that therefore *all such small terms may be neglected*, as introducing needless complexity into the calculation. For this reason the factors depending on "local attraction" and on the variation of gravity both in latitude and in altitude may be neglected: one of the "constants" will however be suitably altered so as to *approximately* include the effect of variation of gravity in altitude.

With this simplification and with the following notation:—

$z$  = Altitude of upper station above mean sea level in feet.

$h$  = Height of barometer at upper station, } both measured in inches, and *reduced* to 32° Fahr.

$H$  = Height of barometer at sea level (required), } both in degrees Fahr.

$t$  = Temperature of air at upper station, } both in degrees Fahr.

$T$  = Temperature of air at lower station,

the simplified formula required for finding  $H$  is

$$\text{Log } H = \text{log } h + z \div \left\{ 60360 \left( 1 + \frac{T + t - 64}{986} \right) \right\} \dots\dots (1).$$

Observe that the premiss of "relative equilibrium" of the air between the two stations will involve in strictness.

\* This reduction is usually done at the observing station, in Meteorological practice.

REDUCTION OF BAROMETRIC READINGS AT HIGH STATIONS, ETC. 137

- 1°. That all the quantities  $\lambda$ ,  $t$ ,  $T$  should be *simultaneous* observations.
- 2°. That the quantity  $T$  should be determined (either by observation or by calculation) for the sea level *immediately under* the upper station.

10. *Constants in this formula.*—The “constants” (60360 feet, and  $\frac{1}{5138}$ ) proposed by the author for use in this formula are given in Rankine’s Useful Rules and Tables, 1866, page 132, and are believed to be the most recent determinations. The values chosen for the former by different author’s vary slightly: a number of these are quoted below. They are mostly given in metres in the originals: these have been reduced to feet for comparison with the English Tables. Observe that the figure 60360 is such as to include in itself an approximate allowance\* for the variation of gravity in altitude:—

Authority.	CO-EFFICIENT	
	In metres.	In feet.
Theoretical co-efficient from experiments of Biot and Arago, ..	18,317	60,096.8
D’Aubuisson, <i>Traité de Géognosie</i> , Theoretical co-efficient, ..	18,365	60,258.7
Laplace, <i>Mécanique Céleste</i> , Bowditch’s translation, Vol. IV., page 568, derived from comparing the formula with heights geodetically reduced by Ramond, .. .. .	18,336	60,158.6
Poisson ( <i>see</i> Cape’s Course of Mathematics, Vol. II., Art. 459). This co-efficient <i>includes</i> the effect of variation of gravity in altitude, .. .. .	18,393	60,345
Delcros’s Tables, .. .. .	18,336	60,158.6
Guyot’s Tables (in Smithsonian Hypsometrical Tables, page 38),		60,158.6
Loomis’s Tables (in Smithsonian Hypsometrical Tables, page 49),		60,158.6
Dippe’s Tables, <i>Astronomische Nachrichten</i> , No. 1056 of 1856, {	Toises. 9,407.78	60,158.6
Bessel’s Tables, <i>Astronomische Nachrichten</i> , No. 356, .. {	Metres. 18,336	60,158.6
Plantamour, E., <i>Mémoires de la Société de Physique de Genève</i> , Vol. XIII., Part I., page 73, .. .. .	18404.8	60,384.2
W. J. M. Rankine, Useful Rules and Tables, page 132, ..		60,360

11. *Uncertainty of the “temperature at sea level.”*—Laplace’s formula is, as already stated, strictly only applicable to two places, between which there is *relative aerial equilibrium*, so that the “temperature at sea level” ( $T$ ) required for the formula ought to be that of the sea level as close as possible to the upper station.

\* Cape’s Course of Mathematics, Vol. II., Art. 458. Guyot’s Hypsometrical Tables (Smithsonian Collection), page 9.

For high stations *near the sea*, the best value of  $T$  is no doubt that obtained by *actual simultaneous observation* at the nearest seaport.

But for high stations *far from the sea*, (like those in the N. W. Provinces and Punjab,) there are two courses open :—

- 1°. To take for  $T$  the value *actually* observed at the nearest seaport.
- 2°. To take for  $T$  the observed value of  $t$  (temperature at the upper station) *increased* by the increase of temperature due to the depression of the sea level below the upper station.

Both of these methods are (necessarily) very imperfect :—

- 1°. The nearest seaports are so far from the stations in the Himalaya, that the condition of *relative equilibrium* of the whole of the intervening air (involved as a premiss in the investigation of the formula) is necessarily violated.
- 2°. The law of variation of the temperature with the height is at present so imperfectly known that only a rough approximation to the true value of  $T$  can be expected by this method.

The law usually assumed in England is that the temperature increases roughly speaking about  $1^\circ$  Fahr. for every 300 feet of descent, but Mr. Glaisher's balloon ascents render it probable\* that this is *not even a rough approximation*. Mr. Blanford, Meteorological Reporter in Bengal, adopts†  $1^\circ$  Fahr. for every 450 feet of descent (in India): he states that Guyot's allowance of  $1^\circ$  Reaumur for every 100 toises "has been found by a late investigation to be much too great in the case of stations situated on plains and plateaux."

12. *Quantity to be taken for  $T$  in the formula.*—Both methods, 1° and 2°, alluded to, appear so imperfect, that it is difficult to express an opinion on the advisability of either. The author considers that this is a question for practical Meteorologists, and that it would be advisable for the Meteorological Departments of India, in concert, to decide on one *uniform* mode of estimating this quantity for the purposes of the present problem.

13. *Error due to incorrect estimation of  $T$ .*—In consequence of the uncertainty attending the estimation of this element ( $T$ ), it is worth while inquiring the error ( $\delta H$ ) likely to occur in the resulting "reduced barometric reading" ( $H$ ) due to a *small* error ( $\delta T$ ) in the estimation of ( $T$ ) the temperature at sea level.

In the original formula (1°) as it is proposed to ascertain the variation  $\delta H$  in  $H$  due to a small *arbitrary* variation ( $\delta T$ ) in  $T$ , it follows that the variations of the other quantities  $t$ ,  $h$  do not affect the question.

\* Annual of Scientific Discovery, 1864, page 149; On the Use of the Barometer, by Major R. S. Williams, U. S. Engineers, 1868, page 91.

† See his "Meteorological Abstract" for 1872, page 9.

Hence from (1),  $\frac{1}{H} \cdot \frac{dH}{dT} = \frac{-1}{986} \cdot \frac{z}{60360} \cdot \left(1 + \frac{T+t-64}{986}\right)^{-2}$

But  $\delta H = \frac{dH}{dT} \cdot \delta T$ , so that  $\delta H$  is proportional to  $\frac{dH}{dT}$ .

Now *ceteris paribus*,  $\frac{dH}{dT}$  is greatest when  $\left(1 + \frac{T+t-64}{986}\right)$  is least, i. e., when  $(T+t)$  is least.

Assuming then that in Indian climates  $(T+t) = 64$  is the least possible value of  $T$ ,  $\frac{dH}{dT} = 1$ , is the greatest value of  $\frac{dH}{dT}$ .

∴ the numerically greatest value of  $\delta H$  (which is the variation required) is  $\delta H = -\frac{1}{986} \cdot \frac{zH}{60360} \cdot \delta T$ ; so that  $\delta H$  is proportional to  $z$  the elevation of the station, or the effect of an error in estimating  $T$  increases with the height of the station. Assuming then that no station will be higher than 10,000 feet,  $\delta H$  cannot exceed (numerically)  $\frac{-10000}{986 \times 60360} \times H \cdot \delta T$ ,

i. e., an error  $\delta T$  in estimating  $T$  produces an error in  $H$  less than  $\frac{H}{6000} \times \delta T$

i. e., an error of 1° in estimating  $T$  produces an error in  $H$  less than  $\frac{H}{6000}$ .

Hence, since the greatest possible value of  $H$  is 30 inches, it follows that

“An error of 1° in estimating  $T$  produces an error in  $H$  less than .005 in.”

And so large an error can only occur for stations over 10,000 feet above the sea, and when the weather is coldest, i. e., when  $(T+t)$  is less than 64.

14. *Construction of the Tables.*—Laplace’s formula may be thus expressed

$$\text{Log } H = \log h + a.z, \dots\dots\dots (2).$$

where

$$a = 1 \div \left\{ 60360 \cdot \left(1 + \frac{T+t-64}{986}\right) \right\} \dots\dots\dots (3).$$

The Table contains the value of  $\log a$  for the argument  $(T+t)$  for every degree from 50° to 199° Fahr., between which limits it is believed that the quantity  $(T+t)$  will always fall in Indian\* practice.

The Table was calculated by the author himself, and two independent sets of computers, so that confidence may be placed in the figures.

\* The Table would require extension below  $(T+t) = 50^\circ \text{ F.}$  for very cold climates.

TABLE OF VALUES OF LOG  $\alpha$ : ARGUMENT ( $T + t$ ).

+ t	Log $\alpha$	T + t	Log $\alpha$	T + t	Log $\alpha$	T + t	Log $\alpha$	T + t	Log $\alpha$
50	5.225462	80	5.212259	110	5.199448	140	5.187008	170	5.174905
1	25016	1	11826	1	99028	1	86595	1	74508
2	24569	2	11393	2	98607	2	86187	2	74110
3	24123	3	10961	3	98187	3	85778	3	73714
4	23678	4	10530	4	97768	4	85371	4	73318
5	23233	5	10098	5	97349	5	84963	5	72921
6	22789	6	96677	6	96931	6	84557	6	72526
7	22346	7	92936	7	96512	7	84150	7	72130
8	21902	8	88806	8	96094	8	83744	8	71735
9	21459	9	83377	9	95677	9	83338	9	71340
60	5.221017	90	5.207947	120	5.195260	150	5.182933	180	5.170946
1	20574	1	07519	1	94842	1	82528	1	70552
2	20138	2	07090	2	94425	2	82123	2	70159
3	19691	3	06662	3	94009	3	81719	3	69765
4	19251	4	06234	4	93596	4	81315	4	69373
5	18811	5	05807	5	93183	5	80912	5	68980
6	18371	6	05380	6	92768	6	80509	6	68588
7	17932	7	04953	7	92353	7	80106	7	68196
8	17492	8	04527	8	91938	8	79704	8	67805
9	17055	9	04102	9	91525	9	79302	9	67414
70	5.216616	100	5.203677	130	5.191112	160	5.178901	0	5.167023
1	16179	1	03252	1	90700	1	78499	1	66632
2	15743	2	02828	2	90286	2	78098	2	66241
3	15306	3	02404	3	89873	3	77698	3	65855
4	14869	4	01981	4	89465	4	77298	4	65464
5	14433	5	01557	5	89053	5	76898	5	65076
6	13998	6	01135	6	88642	6	76499	6	64687
7	13563	7	00712	7	88232	7	76100	7	64298
8	13128	8	00291	8	87822	8	75701	8	63909
9	12693	9	5.199869	9	87412	9	75303	9	63522

15. Use of the Table.—This can present no difficulty to those who are familiar with the use of logarithms.

The rule for use of the Table may be thus expressed in words, but the Table cannot be used without a familiarity with the practical use of logarithms. A modification is suggested in Art. 16 by which Tables could be constructed involving *only a single multiplication*.

1. Add the tabular quantity, (*i. e.*, log  $\alpha$ ) corresponding to the sum of the temperatures ( $T + t$ ) of the sea level and upper station to the common logarithm of the height ( $z$ ) of the upper station.

[*Caution.* Observe that the "characteristic" of log  $\alpha$  is always *negative*, and its "mantissa" *positive*].

2. Find the "natural number" corresponding to the quantity just obtained (*via.*, log  $\alpha + \log z$ ) considered as a common logarithm, and add it to the common logarithm of the barometric reading ( $A$ ) at the upper station (reduced to 32°).

3. The "natural number" corresponding to this last sum considered as a common logarithm is the reduced height (H) required.

*Example.*

Upper Station, Chukrata, elevation, or .. ..	$s = 6884$ ft.
Mean Barometric reading reduced to 32° F. for } May, 1872, at Chukrata, .. .. }	$h = 23260$ in.
Mean temperature for May 1872, at Chukrata,	$t = 66°$ F.
Mean temperature for May 1872, at Calcutta,	$T = 87°$ F.
Hence $(T + t) = (87 + 66) = 153$ .	
$\text{Log } a = 5.181719$ (from the Table)	
$\text{Log } s = 3.837841$ (constant logarithm for the upper station).	
$\frac{1.019560}{\log h} = \log$	$.104607$
$\log h =$	$1.866610$
<hr style="width: 50%; margin: 0 auto;"/>	
$1.471217 = \log 29595$ .	

∴ H = 29595 inches, the reduced Barometric reading required.

16. *Further simplification for particular stations.*—Call  $\zeta$  the "natural number" corresponding to the quantity  $az$  in formula (2) considered as a "common logarithm", so that  $\log \zeta = az$ . Then the formula (2) is easily reduced to the *far simpler form*, peculiarly suited to those who are not familiar with the use of logarithms,

$$H = \zeta \cdot h \dots\dots\dots (4).$$

Here  $\zeta$  is evidently a function of the temperatures  $(T + t)$ , and also of the elevation ( $z$ ) of the upper station.

To enable this simple formula to be used, it would be necessary to construct for each high station a Table of the values of  $\zeta$  with the argument  $(T + t)$ , for every degree of temperature required as before. This may be readily done by any good computer from the Table already given of the values of  $a$ .

The simplification resulting is so great—a single multiplication being alone required—that it would probably be well worth the while of each Meteorological Office to have special Tables prepared for each of its own high stations.

17. *Practical application of the reduction.*—It appears to be admitted (see Guyot's opinion, Art. 8), that the application of Laplace's formula to single observations cannot be expected to yield correct results, but that the mean of the results of its application to many individual observations does yield good results.

Little confidence could therefore be placed in the reduction of the



regular *hourly* or *daily* barometric readings of a high station to sea level. by its use, but considerable confidence could be placed in the *mean* of the results of reducing the separate *hourly* or *daily* barometric readings of a whole month to sea level.

The *practice* of Indian Meteorologists, however, appears to be\* to apply the reduction only to the *mean of the month's readings*—both for high and low stations—and to consider the result to be the “Reduced mean monthly barometric reading.” The *strict* course would of course be to apply the reduction to the individual observations, and take the *mean of these results* as the required “reduced mean monthly barometric reading.”

It is to be observed, that except in the simplest kinds of processes, the result of applying a given process to the *mean of the data*, is by no means the same as the mean of the results of applying the *same* process to the individual data. But when the *variation* of the data is *very small*, the two methods do give approximately the same result.

Whether the problem in hand is one of those cases in which the results of the two methods are either *alike* or *approximately the same*, the author is unable to say.

Looking however to the great uncertainty (Art. 11) attending the estimation of one of the data (the temperature *T* at sea level), it seems doubtful whether the result obtained by employing the strict method would be *worth the great trouble* attending its use, compared to the case of the simpler method.

The author considers this to be a question for practical meteorologists; the adoption of a *uniform* method by the Meteorologists of India (even if confessedly somewhat inaccurate) would probably be preferable to the adoption of methods of greater accuracy by some.

A. C.

---

\* See the Explanation of Table IV., at page 9, of the Bengal Meteorological Abstract for 1872.

---

No. CXIV.

---

## BULL'S FIXED CLAY-CUTTER.

[Vide Plate XIX].

---

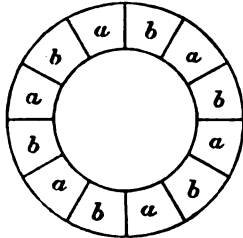
BY W. BULL, ESQ., C.E., *Resident Engineer, Oudh and Rohilcund Railway, Lucknow.*

---

THE want of an efficient machine for undercutting the clay or other hard stratum beneath the curbs of wells has been, and is, greatly felt. It is a comparatively simple matter to excavate below the level of the bottom of the curb a hole equal in size to the interior of the well it is desired to sink, and this has frequently been done to a depth of 15, 20 and 22 feet without the well moving in the least, although weighted to the utmost extent. Attempts have been made to supply the want above alluded to, and two years ago I designed and patented a machine which I had found to answer perfectly, but as I never could get anybody to use it, it can hardly be called an eminent success. Bearing in mind the great difficulty of getting any machine worked, as it necessarily must be, at the top of a comparatively small hole, to excavate hard subsoil from the bottom of this hole, it occurred to me that by the addition of a fixed clay-cutter firmly joined on to the curb, the passive and economically applied agent, "weight," might be induced to do the cutting-in part, and thus leave only the raising of the broken up material to be done by a machine for that purpose. The solid ring of clay or other hard stratum which remains under the curb after a hole has been excavated in the middle of the well, may be likened to a number of arches butting against, and supporting, each other. With the ordinary form of curb, until the

whole of the material forming these arches is completely disintegrated, the well cannot possibly sink, and in some strata no weight that can be put on a well has been found sufficient to do this. The cutters described below, by removing, as it were, the abutments of these arches, leave only, as the duty of the portions of the curb between the cutters the severance of the segmental pieces of clay thus left, which are held by adhesion only to the clay outside.

There should be four or more cutters fixed to each curb, according to the size of the well, which would remove the portions marked *a* in the sketch, leaving the parts *b* to be cut off and forced in by the curb.



The action of the cutters is thus very simple, and it will at once be seen that the power necessary to remove or break out the portions *a*, *a*, when not wedged in by *b*, *b*, will be infinitely less than the power required to cut in or break up the whole ring. The resistance offered by the parts *b*, *b*, would of course be very slight.

In experimenting to prove the correctness of the above theory, it was with a trial curb, made to scale of two feet diameter. This I fitted with six cutters, and built up two feet high, with segmental pieces of wood, and tried it on the hard dry upper surface of the ground. I also had a similar curb without the cutters, but in all other respects the same. The former I loaded with two tons, and the latter with four. The former sank down fully to its full depth of two feet six inches, by digging the hole in the middle, the latter never moved.

The advantages claimed for this invention are:—

1st.—Its simplicity.

2nd.—Its applicability to any curb, a section of which is all that is necessary to enable the cutters to be made.

3rd.—Its saving the undercutting the sub-soil beneath the curb by either machines or divers, both most expensive in operation, and slow in progress.

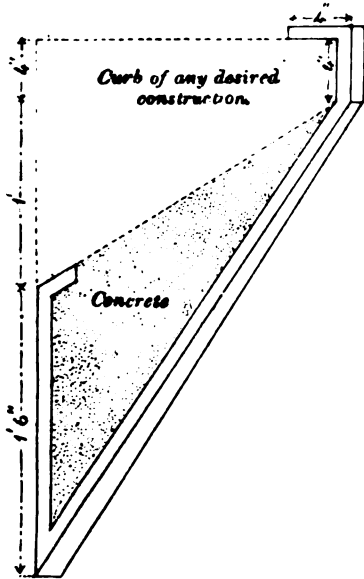
In pure sand, these cutters would, I believe, make hardly any difference, but whenever clay, kunkur, or any mixture of clay and sand may be expected, they will be found of the greatest service; in some cases rendering much less weight on the wells necessary, and in others by means of weight

**BULL'S FIXED CLAY-CUTTER.**

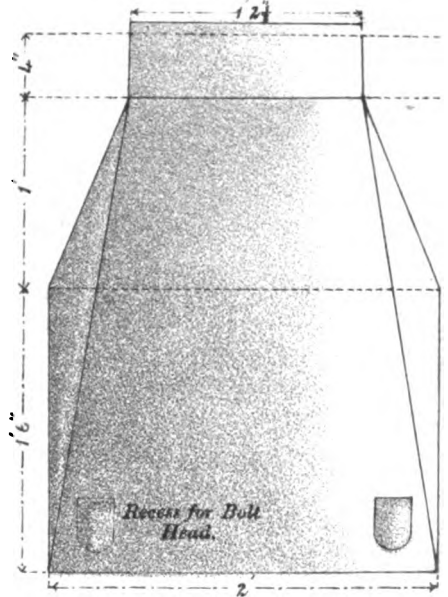
For an Eight Foot Curb.

Scale,  $\frac{1}{8}$  full size. 1 inch = 1 foot.

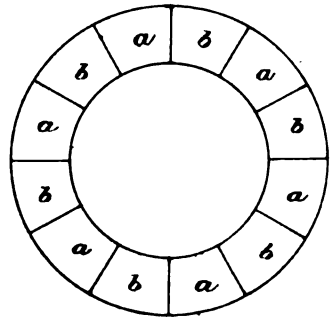
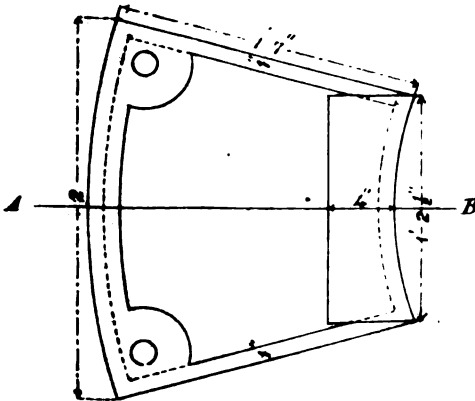
Section at A.B.



Elevation



Plan





alone allowing of a much more rapid progress than has hitherto been possible when divers or machines have had to be used.

It may be found an advantage to make a complete curb of cast or wrought-iron segments, which when bolted together, would be of similar shape to an ordinary curb with the cutters fixed to it, the principle on which each would work being the same, viz., that of breaking up the sub-soil at different levels, and practically speaking, dividing out the duty to be done.

W. B.

## No. CXV.

## BRICK AND TILE MANUFACTURE AT ALLAHABAD.

[ *Vide* Plates Nos. XX. to XL.]

BY MAJOR G. P. DEP. FALCONNET, R.E., *Supdg. Engineer, 6th Circle, Military Works.*

THE manufacture of good Bricks and Tiles, being a subject of considerable interest to all persons connected with the erection of Buildings in India, the following brief description of the manufacturing operations as carried on by the II. Allahabad Division, Special Military Works, during the working seasons of 1872-73-74, is given with the hope that it may prove useful.

The form and make both of Bricks and Tiles was excellent, and the tiling even when laid in single layers only, was found to be perfectly water-tight, but when laid double, (*vide Plate XXIV.*) it forms, it is believed, one of the cheapest, coolest, and most effective coverings for roofs in India.

The Brick and Tile fields were under the immediate supervision of Mr. J. Beale, Sub-Engineer, whose experience in the manufacture of Bricks and Tiles was acquired in England, and to his practical knowledge and constant supervision, the excellent quality of the articles produced is to be attributed.

The general success which has attended the operations and the satisfactory financial results of the manufactory are mainly due to

the superintendence of Mr. R. Tyndall, C.E., the Exec. Engineer, during the working seasons above alluded to, and from whom, as well as from Lieut. Laugharne, R.E., the writer has received much valuable assistance, in the compilation of this article.]

---

**Selection of Material.**—Before describing the different processes of the manufacture, a few remarks on the material used for Bricks and Tiles may be found appropriate.

The qualities to be sought for may be thus detailed. Hardness to enable the articles to withstand pressure and cross strain; soundness, that is freedom from flaws and cracks; uniformity of size; regularity of shape; uniformity of color and facility of cutting.

The combination of the above qualities depends almost entirely on a proper selection of the earth and its judicious preparation before the actual process of Brick or Tile making is commenced; the subsequent operations are matters of mechanical routine.

The argillaceous earths suitable for Bricks and Tiles may be divided into three principal classes as follows:—

**LOAMS**, which may be described as light, more or less sandy clays.

**MARLS**, which may be described as earths containing a considerable quantity of lime.

**PURE CLAYS**, composed chiefly of one-third alumina with two-thirds silica, but generally containing a small proportion of other substances, such as lime, iron, magnesia, salt, &c.

It does not always happen that earths are found which in their natural state are suited for the manufacture of bricks and tiles without some admixture. The pure clays require the addition of sand, loam or some milder earth; the loams on the other hand are frequently so loose that they cannot be made into bricks without lime being added to flux and bind the earth. Even when the clay requires no admixture the difference in the working of various portions of the same field is frequently so great, that it is advisable to mix two or three sorts together to produce uniformity in the size and color of the articles, or else to regulate the size of the moulds for each part of the field.

Alumina is the most important ingredient in all brick earth, and it is



this which gives to clay its plastic character. Alumina alone or the pure clays containing but little sand may with ease be moulded into any shape, but will shrink and crack in drying, no matter how carefully and slowly the operation may have been conducted. It will not stand firing, as a red heat causes the mass to rend and warp, although it becomes very hard by the action of the fire.

The addition of any substance which will neither combine with water, nor is subject to contraction, greatly remedies these defects, whilst the plastic quality of the clay is not materially affected. For this reason the strong clays are mixed with milder earths or with sand. The loams and marls are mixed with lime.

The color of the burnt articles depends on the chemical composition of the earth employed, and not on its natural color before being burnt. If iron be present without lime or similar substances, the color produced at a moderate red heat will be red, the intensity of color depending on the proportion of iron. If the clay be slightly fusible, an intense heat vitrifies the outside of the mass and changes its color to a greenish blue. The addition of lime changes the red produced by the oxide of iron to a cream brown, whilst magnesia brings it to a yellow. Few clays produce a clear red, the majority burning of different shades of color, varying from reddish brown to a dirty red, according to the proportion of the substances which they contain.

It is almost impossible to describe how it is best to select the clay required for the manufacture; it varies so much in different localities and even in the same field: it is sometimes found as a deposit in rivers, generally on the surface or a little below it of alluvial plains. The best way of ascertaining the quality of the material, on which the size to which the articles may be made and their quality entirely depends, is by actual experiment. Pure clay will not be found workable as it cracks and twists in drying, but clay mixed with sandy alluvial deposit, or with fine sand should be sought after, and when found experimented upon before operations on a large scale are commenced. If a manufactory exists within a reasonable distance of the locality where new brickfields are proposed to be started, it is recommended that samples of the various descriptions of clay found and proposed to be employed, be sent to its manager for the purpose of being moulded into trial bricks and tiles, these could be marked and burnt with the articles of the manufactory in question under

better conditions than would otherwise be the case, and by the results of such trial the selection of the clay would be guided.

**Brick Manufacture.**—The manufacture of bricks will be described under the following heads:—

- I. MOULDING AND DRYING.
- II. LOADING.
- III. FIRING.
- IV. RATES AND MISCELLANEOUS.

**I. MOULDING AND DRYING.**—The first operation is the excavation and preparation of the clay.

The clay having been excavated should be spread out to be scorched by the sun, after which it is soaked with water, turned over and tempered (*i. e.*, trodden down, all large lumps being broken up) for six days, before being carried to the moulding grounds, but it is better to follow the more preferable course of excavating the clay before or during the rains, and allowing it to weather throughout them.

The clay having been thoroughly tempered, is then taken to the moulding grounds, heaped up there, and pugged by feet in the following manner:—

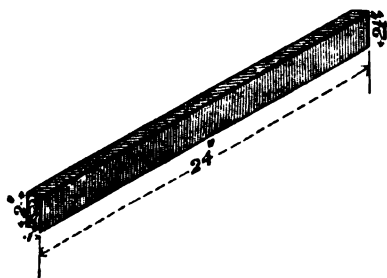
Two men stand on the heap and tread it down, a third cutting off, with a clay cutter, the edges as they bulge out, and throwing the pieces on to the top, where they are again trodden down.

This continues until the clay being perfectly homogeneous, and free from all foreign substances, is fit to be moulded into bricks.

A description of the moulding ground, moulds, tables, &c., will now be given.

**Moulding Ground.**—The size required having been marked out, (about 40 to 50 feet square for one table,) the grass and irregularities are removed, and the surface thoroughly flooded over night, this causes it to be sufficiently soft in the morning, to allow it to be scraped with a scraper 24 inches long shod with hoop iron of the shape and size shown in the margin. This process is con-

tinued for 3 or 4 successive days, until the ground has attained a perfect



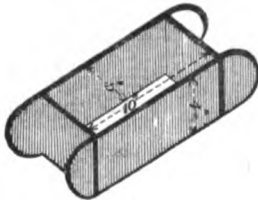
level, which is absolutely necessary for drying bricks upon without injury to their shape.

When in use, the part of the moulding ground where bricks are to be placed during the day, is scraped over before commencing work: very often, instead of the scraper above-mentioned, iron hoops about one foot diameter are used.

*Moulding Table.*—A block of wood about 15 inches diameter and 15 inches long, is either let into the ground, or built into a mud wall, about  $3 \times 5$  or 6 feet, and of a convenient height for the moulder (generally 2 feet 6 inches); if let into the ground a hole is dug for the moulder to stand in.

The block of the brick mould is nailed on to this block of wood; this method gives a more solid bed for the moulder to work on, than if an ordinary table was used, as is very often the case.

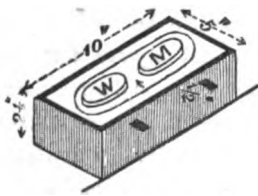
*The Mould.*—The mould is made of seesum wood, bound with thin iron, and is of the following dimensions, viz.,  $10 \times 5 \times 4$  inches, fitting  $\frac{1}{2}$ -inch over the block, and resting on iron pegs let into the latter. The size of mould will have to vary with the description of clay, and must be so regulated that when burnt, twice the breadth of the brick, plus a quarter of an inch, should equal the length.



*Block.*—The block is also of seesum wood, and consists of a piece of wood about  $2\frac{1}{2}$  inches thick, and of the exact length and breadth of the mould, which fits over it. A thin piece of counter-sunk sheet iron runs round the upper surface of the block, about  $\frac{1}{2}$ -inch wide. On to the upper surface of this block, and within the sheet iron, two pieces of wood about  $\frac{1}{4}$ -inch thick

are nailed, on these the letters required to appear on the finished brick are cut. Two hollows are consequently produced in the brick, which are required to afford greater hold to the mortar.

*Strike.*—The strike is a piece of sál wood, about 1 foot long by  $2 \times \frac{3}{4}$  inches, and is replaced each day, the old ones being planed over, before being again brought into use.



*Water Box.*—The water box is made either of wood, or an open mouthed gurra is used, it should be sufficiently large to allow of the strike being completely immersed in it.

*Pallets.*—The pallets used for carrying the bricks from the moulding table to the drying ground are made of deal, and are made about  $12 \times 6\frac{1}{2} \times \frac{1}{2}$  inches; great care is necessary to see that these are not in the least warped, as otherwise the brick is never of a good form.

*Wire-cutter.*—The wire-cutter consists of a single piece of wire, with a rag twisted round each end, to form a handle.

*N.B.*—All the above articles must be scrupulously washed at the close of the day's work, and the moulds, strikes, and pallets should be kept in water during the night.

*Moulding.*—The description of the moulding will now be given. When the men who are pugging have reduced the clay to a proper consistency for moulding, sufficient for a brick is cut off from the heap, and kneaded on a loose board, into a ball-shaped mass, after which, it is placed on the moulding table.

The moulder after sanding the kneading board, rolls this ball, and lengthens it into an oblong shape, and then throws it into the mould, previously sanded, with as much force as possible, giving it three blows with his hand, in order to consolidate the clay, and force it into the corners of the mould.

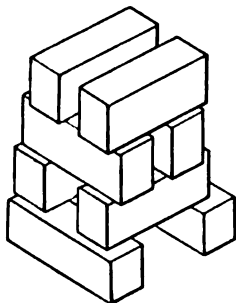
Care should be taken that the clay is neither too wet, nor too dry, as if the former is the case, the brick will not dry straight, *i. e.*, the brick will sink and become wider at bottom than at top; and if too dry it will be liable to crack, moreover the mould will not fill out properly, the spaces in the corners remaining empty, and greater difficulty is experienced in removing the mould.

The moulders should also be instructed to force the clay into the mould with equal power, otherwise the bricks will not be uniform in size, unequal shrinkage taking place; hence they are instructed to strike three times.

The superfluous clay is now cut off, with a bit of wire drawn across the top of the mould, the brick is sprinkled with water and smoothed with a strike, which is dipped in water each time before use, the moulder then sands the top surface and afterwards stamps the brick with a wooden stamp, on which his number is cut, this produces a "kick" in the bed of the brick, the other bed has two such, as already described.

A pallet board having been placed on the top, the mould with the brick in it is sharply inverted, the mould withdrawn, fresh sanded for another brick, and replaced on the block, leaving the brick resting on the pallet on the left of the moulder.

*Drying.*—A boy now comes, and placing another pallet on the top of the brick, carries it off between the two, and sets it carefully down on edge on the drying ground; the bricks are placed in parallel lines, a half inch space (the thickness of the pallet board) being left between each brick; they are left like this, until sufficiently dry to stand from four to six high, when they are scintled, that is built up in little open stacks to allow the air to pass through them, and so dry them quickly; this scintling is only necessary in the cold season.



The bricks take from two to fourteen days drying, before they are ready for the kiln, according to the time of the year. If no kiln is ready when the bricks are dry, they are stacked in loose walls until one is empty.

II. **LOADING.**—Care should first be taken to see that the floors between the fire-holes or “rouses” are perfectly level, or the whole of the kiln will be thrown out in the loading.

The sun-dried bricks are brought to the kiln, and loaded in the following manner:—

The first three courses are laid on edge over one another, with a space of one finger between them, (*see* Section and *Fig. 1.*)  
**PLATE XX.** the lowest resting on the rouse, the centre space insufficient for a brick placed lengthways like the outer ones, being filled by a brick laid in the contrary direction.

In the fourth course the bricks facing the fire-holes are set closely together, those at the back being loose, as before, (*see* Sections and *Fig. 2.*)

The fifth, sixth, and seventh courses are laid like the first, second, and third, with spaces.

The eighth course commences the corbelling over fire-holes, when the kiln is of dimensions shown in (*Plate XXIII.*), the rule being that the first corbelling course should be about 3 inches above the crown of the

firehole. In this course the bricks facing the fire-holes, are again placed close as in the fourth course.

The ninth, tenth, and eleventh courses complete the corbelling, and in these the bricks are set directly over each other, so as to allow the fire to come up between them, (*Plate XXII.*) The space in the centre, between the fire-holes in each course, must be filled up in the most convenient manner, either with bricks scintled, or with headers and stretchers as space allows, but not packed tightly together, (*Figs. 2 and 3.*)

The twelfth course is called the pocket course, and is set across the *others*. It must be tightly packed, in order to bind all the other courses together. The pockets allow the fire to come up through them, (*Fig. 4.*)

The kiln is now filled with alternate layers of headers and stretchers, a space being left all round the kiln at about 3 feet from top, as shown, (*Plates XXI. and XXII.*) to allow of coal, &c., being put in during the firing. The width of this place depends on

PLATE XXI. the fuel which it is intended to use (*see* description of firing further on) for coal  $2\frac{1}{2}$  inches at top and 2 inches at bottom, is the proper width to give; for charcoal 5 inches at top and 4 inches at bottom; for charcoal and coke mixed in equal proportion, same width as for coal. The way this space is covered over with bricks, laid flat and close together, is shown in *Plate XXI.*, and in *Fig. 5, Plate XX.*

The top course is also of bricks but laid flat, and with spaces between them, as in the other courses, (*Fig. 5, Plate XX.*)

The partition, or tum-tum, in the centre of the fire-holes, dividing the fires, is built up loosely in no particular form, one or one and a-half bricks thick, and is carried up to the top of the corbelling, the object of this partition is to act as a guide to the burners, and prevent them throwing their fuel too far, (*Plate XXII.*)

At each end of the kiln, during the process of loading, wood is built in at the back of the bricks, in order to heat the end  
PLATE XXII. wall, and draw the fire towards that part, (*Plate XXI.*) this wood lights itself from nearest fire-hole.

III. FIRING.—The firing is commenced by placing a few small pieces of lighted wood in each fire-hole, keeping them on the wall of the kiln (*i. e.*, not dropping them into the trough or fire-hole proper); the fire is gradually increased until the kiln is well heated, and the bricks at the

bottom thoroughly dried, this will be in about 36 hours in the cold season, and 18 in the hot season.

At the end of this time, the fire doors or dampers should be put on, which will cause the fires to burn with greater vigour; and now when fresh wood is added, the half burnt pieces already in the fire-hole, should be pushed down into the troughs towards the centre of the kiln. The fire doors are made of sheet iron  $\frac{1}{8}$  to  $\frac{1}{2}$ -inch thick, 21 inches wide, 24 inches high, hung by means of a hook 9 inches long, to a peg fixed in the wall of kiln above each fire-hole. In each fire door there is a peep-hole,  $1\frac{1}{2}$  inches diameter, centre of which should be  $7\frac{1}{2}$  inches from top of door; there should also be a hole 1 inch diameter at top for the hook to pass through.

In about 48 hours from the commencement in the cold weather, (and 24 to 36 hours in the hot season,) the bottom of the kiln will show a red heat, and the top of the kiln will in places be hot enough to ignite the fuel that may be spread over the top course of kiln; consequently a  $1\frac{1}{2}$ -inch thick coat of coal or else a 4-inch coat of charcoal is spread on the top, and as it ignites in places, the ignited coal or charcoal is stopped down with 3 inches of moist clay; the fire is thus forced towards the other parts, and little by little the whole of the coal or charcoal becomes ignited, and is stopped down until the whole top surface of kiln is covered over with clay with the exception of the spaces round the sides and ends, which are left unstopped, but which are still covered over with the loose bricks as before described. Whilst the above process is going on, the fires are reduced, less wood being employed.

*N.B.*—At Allahabad where coke is obtainable from the gas works, a two inch coat of charcoal and coke is now used, the coke and charcoal being in equal proportions. The above thickness suits the Allahabad clay, but elsewhere it may be necessary to employ thicker coats.

As there is now very little escape for the heat, the firing must be most carefully watched, a small excess of fuel causing the fire-holes to melt very quickly, the fire should therefore be again kept on the walls of the kilns, *i. e.*, not in the trough or fire-hole proper, and the larger pieces of wood employed, as they burn more slowly. This method of firing is continued to the end, unless the appearance of the fire-holes (or tum-tums) shows that more fuel is required in the fire-hole proper in which case some is thrown in.

During the time the top fuel is burning, all the heat escapes at the sides, which, consequently, get red hot, and in about 24 hours will be sufficiently so to ignite fuel placed there; consequently, the bricks covering in the empty space round the sides and ends of the kiln at top, are lifted up (10 or 12 at a time), and coal or charcoal dropped into the space; the bricks are then again replaced, and as the fuel dropped down, ignites; clay is put over them as was done over the rest of the kiln, until the whole kiln is covered with clay. During the above process the fire-holes are cleaned, *i. e.*, all charcoal found in the troughs is stirred up with the poker and the ashes are raked out.

After the above is completed, holes are pierced with an iron bar, all over the clay covering at top of kiln, about two feet apart, but none (at this period) within three feet of the sides and ends. These holes will draw the heat from the fuel dropped down the side and end spaces, through the bricks towards the centre of the kiln. The fires must be carefully regulated as there is but little escape at top.

After the holes have been pierced, the kiln is carefully watched, so that equal heat may be distributed all over it. This is done by covering over the holes, which show a good bright red heat with cakes of clay, thus stopping the currents of heat in this direction, and, causing them to find fresh vents for escape, and where the appearance of the bricks, as seen through these holes, shows that the heat is insufficient, additional holes are pierced through the clay covering until the proper heat has been attained, when they in their turn are stopped up. The burning is continued until a bright red heat has been observed all over the kiln. It is found necessary sometimes to drop coal or charcoal two or three times down the side and end spaces; generally it is necessary to do this twice at the corners and at the ends over the built up doorways. During the whole time that firing is going on, charcoal and ashes must not be allowed to collect or bank up in the fire troughs, and the draught holes at bottom must be kept perfectly clear. When charcoal banks up, a long iron poker is driven into the mass through the fire-hole, and the poker jerked up and down so as to loosen the mass and admit air; as the charcoal that may bank up close under fire-hole, cannot be reached, the poker is also driven through the draught holes. After this is done the ashes are raked out by means of a long iron bar with a crook at one end. There are no regular periods for doing this, it depends very much on the quality of fuel



and on its state of dryness. Very dry and good fuel forming only ashes and not charcoal.

Another test of the kiln being properly burnt is, when a settlement of 3 or 4 inches has taken place; the vents where this takes place first, must be stopped down, and the firing underneath them diminished, until the whole has settled uniformly.

As soon as the firing is completed, all the openings must be made and kept thoroughly air-tight with wet clay; this is especially necessary at the bottom. The kiln is thus allowed to cool gradually for about 8 days, when it may be opened at the top, care being taken never to open the kiln at the bottom, until the materials are thoroughly cool. The total time of firing at Allahabad is about 96 hours, but the duration of this operation depends almost entirely on the quality of the clay and fuel.

Instead of piercing holes over the kiln, a better plan is to fix upright cylindrical pipes, about 1 foot in length, and  $2\frac{1}{2}$  inches diameter, into the top course of bricks, covering them over with cakes of clay, when the coal is being put on. These cakes are taken off at that period when, as above described, holes would have been pierced, and are replaced at that period when the holes would have been stopped up.

These pipes are much used at Allahabad, as there is a large quantity in stock, and when tiles are being burnt in the kilns, at same time as bricks, they are most desirable, but for the manufacture of bricks alone, it would scarcely be necessary to make them for this purpose, the holes answering almost as well.

IV. RATES AND MISCELLANEOUS.—The following was the arrangement formerly in force, but it has lately been changed; the new method will be given further on.

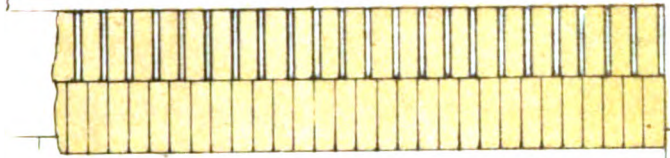
At the commencement of the season, all the kilns and moulding floors were put in order by the Department, the preparation of new moulding floors being paid for at the rate of Rs. 1-4 per table, and old ones at Rs. 1, but after a floor or kiln was thoroughly put in order for the season, it had to be kept so at the Contractors' expense.

The bricks when they came out of the kiln were paid for at the rate of Rs. 1-10 per 1000, all classes, as well as broken pieces, being paid at the same rate, the latter being calculated at 10 bricks per cubic foot.

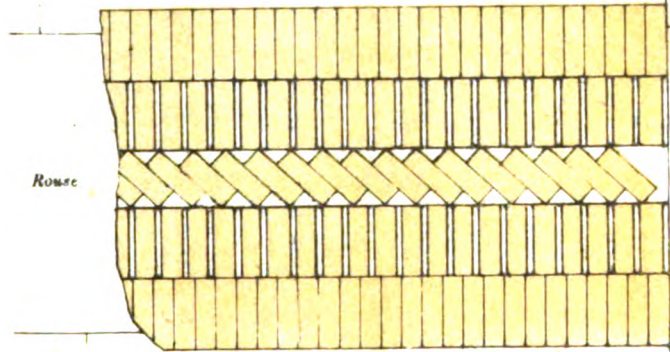
This rate included excavating, pugging, moulding, loading, and unloading. If there was any loss in kutchha materials from inclement wea-

AHABAD

PLAN OF NO. 8 COURSE.  
Fig. 3.

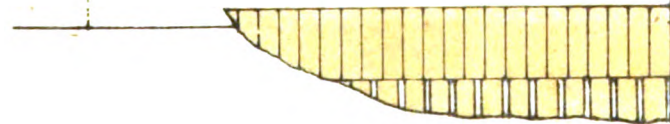


*Fire Hole*

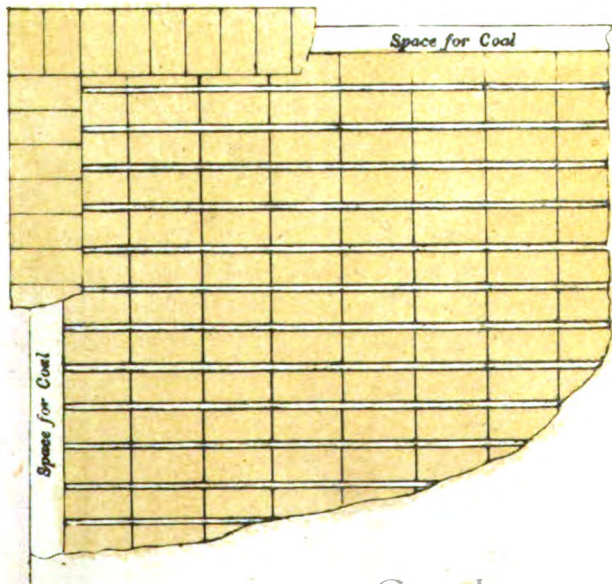


*Rowe*

*Fire Hole*



PLAN OF TOP COURSE.  
Fig. 4.



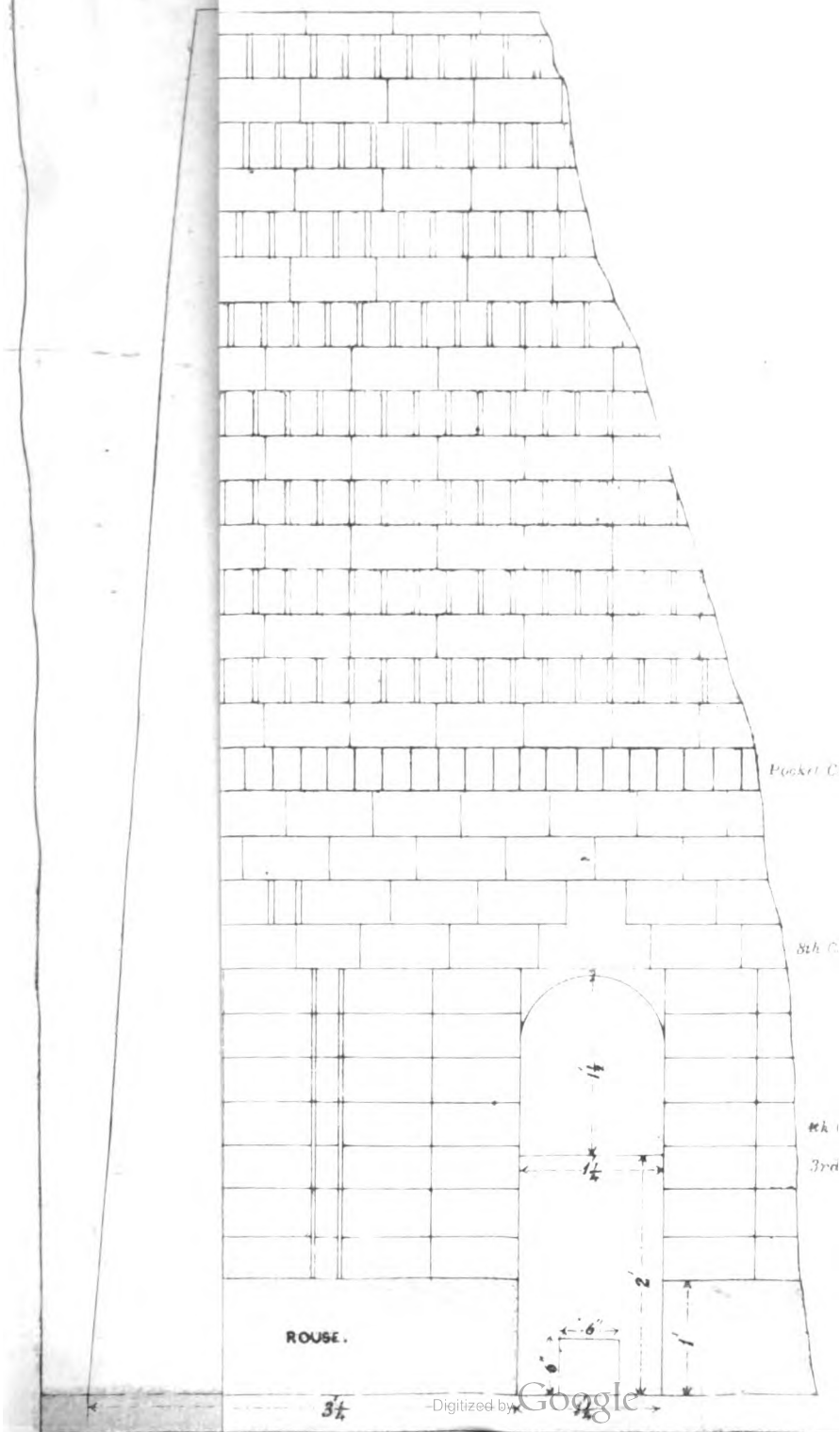
*Space for Coal*

*Space for Coal*



HABAD.

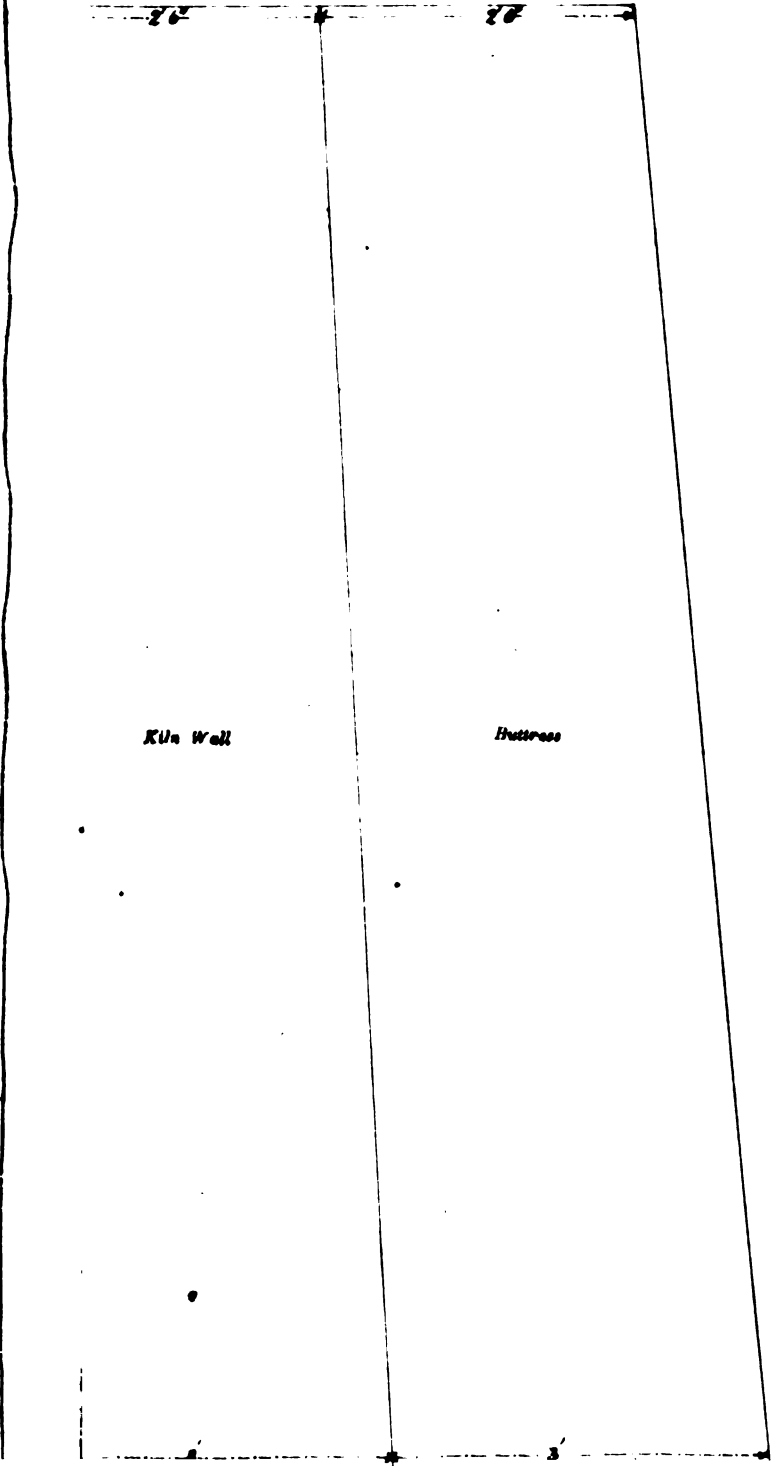
← SECTION OF KILN.





ALLAHABAD

OSB SECTION OF KILN.



*Kiln Wall*

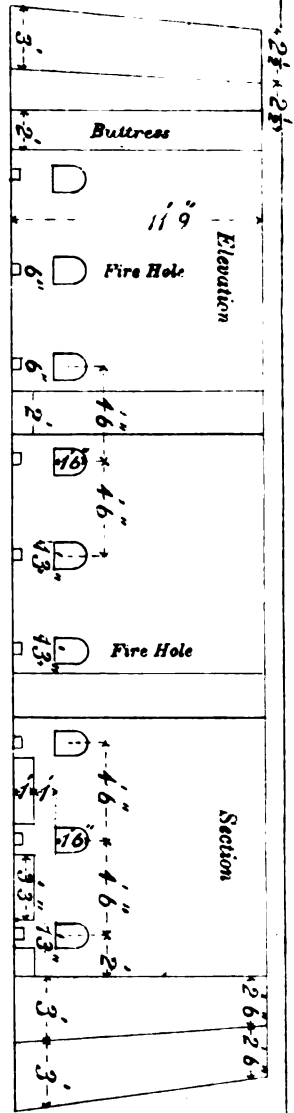
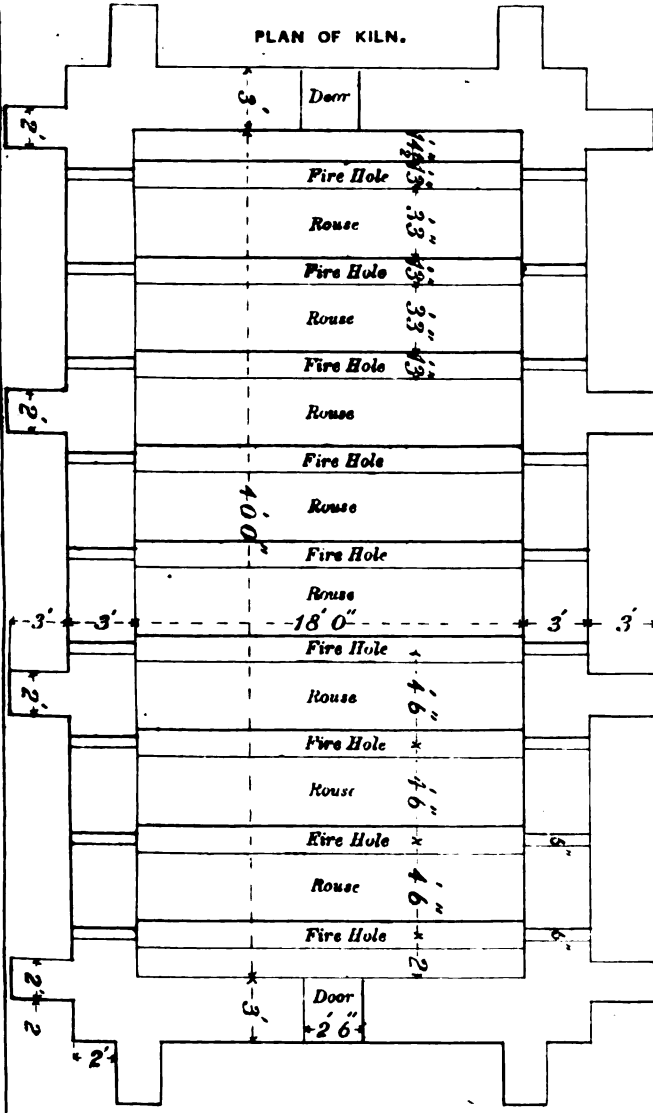
*Buttress*



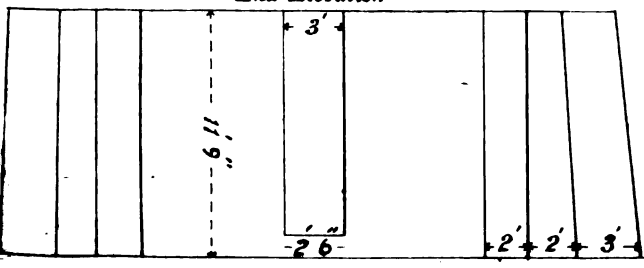
BRICK MANUFACTURE-ALLAHABAD

Scale,  $\frac{1}{8}$ " size—1 inch = 9 feet.

PLAN OF KILN.



End Elevation







ther, it was borne by the Department if the bricks had been loaded in the kilns, and by the Contractors if they had not been loaded; except in special cases, such as bricks being ready for the kilns, but none being vacant for them. The moulders found their own water, but sand was given to them, as well as all moulds, &c., the latter were also kept in repair by the Department.

For firing, the men were paid at the rate of  $2\frac{1}{2}$  annas for 12 hours, and two mates at 4 annas per 12 hours, one man being necessary for each fire-hole. Rs. 5 was allowed for putting coal and clay on a kiln with 12 fire-holes (counted on one side of kiln).

The firing gangs had to remove the clay from the top, and clean the kiln up ready for next firing, keeping the inside without extra payment.

A different system has recently been introduced.

A large Contractor takes the whole of the work, and is paid Rs. 2-4 per 1,000 bricks, 1st and 2nd class only being counted, 3rd class and rubbish not being taken into consideration.

This rate includes preparation of clay, moulding, loading, firing, unloading, and stacking produce, together with all *et ceteras* connected therewith; the Contractor bears all loss from inclemency of weather.

The kilns and floors are, at the beginning of the season, prepared as formerly by Departmental agency; and sand, moulds, &c., are provided by the P. W. Department.

The fuel used is principally Mohowa and jungle wood, (all wood except Mohowa, Babool, and Tamarind, is termed jungle wood,) cut in lengths of about 3 feet, and in sizes of from 3 to 12 inches diameter. The average expenditure is 6,000 cubic feet per lakh of bricks, and in addition 135 cubic feet of coal are used per lakh, for top and sides of kilns. When charcoal only is used, 335 cubic feet are required, and when coke and charcoal are employed in equal proportions, 200 cubic feet are required per lakh of bricks.

The prices of these materials are as under:—

Mohowa wood, ...	Rs. 8	0	0	per 100 cubic feet,	} stacked tightly.
Jungle wood, ...	„	6	8	0	
Coal, ...	„	0	12	0	per maund.
Charcoal, ...	„	1	0	0	„ of 6 feet.
Coke, ...	„	16	0	0	per ton.

The materials are delivered at site of kiln, and stacked near them, for these rates.

It should be noted that the height of the kilns may be increased, if the bricks underneath are not found to crack or bulge with the superincumbent weight.

The length of the kiln may also be varied at convenience, keeping  $4\frac{1}{2}$  feet as the distance of the fire-holes from centre to centre.

The first class bricks are brought on stock at Rs. 8 per thousand, their size being  $9\frac{1}{4} \times 4\frac{1}{2} \times 2\frac{3}{4}$  inches. The above rate is exclusive of carriage to sites. From 90 to 93 per cent. first-class bricks have generally been obtained from kilns fired as described.

---

**Tile Making.**—*Description.*—The tiling used, consists of a double layer of flat tiles with the side joints of the lower layer covered over by means of semi-hexagonal, and those of the upper layer with half round, tiles.

PLATE XXIV.

The first layer of flat tiles is laid on battens, each tile lapping 3 inches over the one below it.

A flat tile is shown in *Plate XXVII.*, there are two buttons on under-side of upper edge to hold the tiles in their positions on the battens, and side sides are turned up.

Rows of flat tiles are laid from top to bottom of the roof, each row touching the one next it, and the joint is covered over with semi-hexagonal tiles, which also lap 3 inches over one another; these tiles being made semi-hexagonal in form, give a fair bed for the upper layer of flat tiles to rest on; and this upper layer is laid on like the lower one, the buttons catching in the lugs provided on the semi-hexagonal tiles, (*see Fig. 3, Plate XXXIV.*,) and the side joints are covered over with half round tiles, lapping three inches over each other.

At the ridge where the two planes meet, the ridge tile (*Plate XXXVII., Fig. 3*) is placed, which fits into the upper flat tile on both sides of the ridge.

*N.B.*—To ensure the correct fitting of ridge tiles, the position of the battens must be regulated in every roof by actual trial; two or three battens should be fixed near the ridge, and a double or single layer of tiles laid according to the description of covering specified, and these trial bat-

tens must be shifted until the ridge tiles fit correctly. The position of top batten being thus regulated, all the remainder can be fixed, taking care that the measurements are made from upper edge to upper edge of battens, which must be perfectly straight and 12 inches apart, edge to edge.

The half round ridge tiles (*Plate XXXVIII.*) are used to cover the side joints of the ridge tiles in the same manner as the ordinary half round tiles do those of the flat tiles.

At the hips where two planes meet at an inclined angle, the flat and half round tiles are cut with a saw to meet, and the joint is covered over with the hip tiles built up in mortar and lapping six inches over each other (*Plate XL.*)

The hip cap tile, (*Plate XL.*) is used for the junction of the two hips with the ridge, and is also set in mortar, as are also the ridge tiles, and the three lowest horizontal rows of tiles at eaves. All the other tiles are laid dry both in lower and upper layers; all the tiles must be well soaked in water before being laid in mortar.

In fitting the tiles together, all irregularities should be adjusted by means of rasps, and no cutting tools should be allowed on the roof.

The portions of roof laid in mortar should be kept watered by means of garden watering pots for at least 12 days after they are laid, to ensure slow drying and avoid cracks.

The Manufacture of Tiles, as in Bricks, is carried on under the following heads:—

- I. MOULDING AND DRYING.
- II. LOADING.
- III. FIRING.
- IV. RATES AND MISCELLANEOUS.

I. MOULDING AND DRYING.—*Preparation of Clay.*—The clay required for the ensuing season should, whenever practicable, be excavated during the rainy months of the year, as the lumps break up and crumble with greater facility.

It is stacked in heaps about five feet high, and left to stand till the manufacture commences, when it is watered and tempered (*i. e.*, trodden down and lumps broken as already described for Bricks) for two days, in such quantities as may be required for daily use.

When the clay is not excavated during the rains, it must be spread out

to be scorched by the sun, after which it is soaked and tempered for six days.

*Pug-mill.*—After due tempering, the clay is taken to the pug-mill which consists of a vertical iron cylinder in which eight blades or knives revolve on a spindle.

PLATE XXV.

By means of these knives the clay is cut up, and at same time pressed downwards, small openings near the bottom, allowing the clay to escape.

The clay having been put into this, is soon forced out at the apertures, when it is cut off and again put in at the top, and this continues until the mass coming out proves to be perfectly solid and homogeneous; this takes place in about an hour after the clay is first put in the mill.

The clay as it comes out is then cut off and carried to the moulding shed, where it is placed on the floor of passage near the moulding table, and welded into a heap to prevent its drying quickly; during the hot winds, a wet mat should be thrown over the top to keep it moist.

The supply in the pug-mill is kept up by adding fresh clay at the top, but when the clay once comes from the mill in a homogeneous state, it is cut off and taken to the moulding shed continuously throughout the day, none being re-pugged unless its appearance shows that it is required. The pug-mill must be thoroughly cleaned every evening after work ceases, to prevent dry lumps collecting about the sides and knives, which becoming mixed with the next day's clay would spoil the homogeneity of the tiles.

*Moulding and Drying.*—The various sorts of tiles are moulded in sheds of a uniform pattern, and on a table which is common to all.

*Moulding Shed.*—The shed (of which a Section is shown in *Plate XXV.*) consists of two low walls with a row of pillars in the centre supporting the ridge pole, the whole being covered with grass choppers, or if the manufacture is likely to last more than one year, country tiles make as cheap a covering.

There are two passages running the length of the shed, and on each side of each passage are three earthen shelves made of kutchā bricks well plastered over with kutchā plaster, which must be brought to a perfectly true and level surface, as any defect in these is impressed on the newly moulded tile.

The shelves are made about one inch longer than the tiles, and about five inches high, only three are placed on each side, as with a larger num-

ber, the moulder is liable to step on the lowest shelves in placing the upper tiles, and so destroy the plaster.

*Moulding Table.*—The table consists of an ordinary table, about 6 feet  $\times$  2 feet 6 inches, on substantial legs, which must be well braced to prevent its moving; it stands about 2 feet 6 inches high, but can be adjusted at convenience by each moulder. The kneading board consisting of two pieces of deal carefully smoothed and jointed, is on the right front. The sand box is in the rear centre, and the water box in rear of the space for the mould, which is placed on the left front, with the handle projecting beyond the table end.

*Clay cutter, or clay cutting bow.*—The clay cutter is shown in *Fig. 3*, the wire for cutting the clay, is stretched between the ends of two pieces of wood (AA), these pieces are connected by another long piece (B) from centre to centre, and the wire is tightened as required by means of a small iron rod (D) and nut (E), which connects the other ends of the pieces of wood. The nut being screwed up, brings the upper ends of the pieces (AA) nearer together, separates the lower ends to which the wire is connected, and so tightens the latter.

**FLAT TILES.**—*The mould.*—The body of the mould is made of sál wood, the side pieces (which are generally of mango wood, and bound at edges with  $\frac{1}{8}$ -inch iron) are secured to the body by means of screws, and two bolts with nuts pass from side to side, to prevent the mould from opening out, (*Figs. 1 to 6.*)

The sides of mould regulate the height of the sides of the tile, and at the tail of the mould two pieces of wood project from them to form the sockets for the lap of the tile, these pieces are shown at (P), (*Figs. 1, 2 and 3.*)

At the tail end a guide bound with  $\frac{1}{8}$ -inch iron is fixed, (*see Q, Figs. 1, 2 and 3.*), this gives the thickness of the tile and also that of its sides.

*The fork* consists of three prongs which fit into spaces (DDD) left in the body of the mould, and by means of this fork the tile can be lifted out of the mould.

At the ends, the three prongs (AAA) are fastened to a block of wood, (*see R, Figs. 5 and 6.*) and over them a guide (Q), is fixed similar to the one at the end of the body of the mould.

A handle about 15 inches long projects from the fork to lift it up by;

in the block of wood to which the prongs are fixed, two small holes are made, (*see P, Figs. 4 and 5,*) in order to form the buttons of the tile.

When ready for use, the fork is inserted into the body of the mould and put home, the prongs fitting into the spaces left for them, and the block (R) being forced up tight against the frame at (O), and the fork which might otherwise move while making the tile is held in its place by a pin, (*see K, Figs. 1 and 3,*) the fork should be a little loose, as it swells when at work and wet.

*Dressing Block.*—The dressing block consists of a block of sál wood about three inches thick, with mango wood sides, and is made inside of the exact shape of the outer surface of the finished tile.

The dressing block is smaller than the mould in proportion to the degree to which the clay is likely to shrink, and which can only be decided by experiment, as clays of different localities vary in shrinkage during the process of drying.

*The Dresser.*—The dresser (*Figs. 7, 8 and 9,*) consists of a piece of sál wood very smooth, about  $18 \times 1 \times 3$  inches, with a handle six inches long—all the edges should be taken off.

*Dressing knife.*—The dressing knife (*Fig. 10*) is about  $\frac{1}{2}$ -inch thick.

*Strike.*—The strike (*Figs. 4, 5 and 6,*) consists of a piece of wood about  $24 \times 2 \times 1$  inches, with the keen edges taken off.

*Moulding the tile.*—The moulder stands in front of the table with the heap of clay on his right, and the mould on the left of the table as already described, and proceeds as follows :—

He first cuts off with a clay cutter, (*Plate XXXVI.,*) a piece of clay rather more than sufficient for one tile, and puts it on to the kneading board, (previously well wetted and sanded,) and then kneads it into a ball, which he finally presses out flat to about the size of the inside of the mould. Great care should be taken to prevent sanded portions of the clay getting into the interior of the ball, otherwise the tile is liable to crack in drying or burning.

In kneading, the moulder grasps the left wrist with the right hand, and presses the clay with the heel of the hand; when he has kneaded the piece to a thickness of about two inches, he cuts off both ends, so as to get clean edges, and sprinkles them with sand.

He then pulls the cake of clay towards him with his hands above it,

(palms down,) and as he gets it to the edge of the table, carefully inserts his hands underneath, (palms up,) keeping his fingers perfectly straight, or even a little bent backwards, in order that the points may not run into the clay.

When he has got it thus on his hands, he lifts it up and drops it into the mould, which has been previously wetted and sanded.

He then beats it with his hands to fill out the corners of the mould, taking care not to do it to excess, and pushes his thumbs into the clay above the holes provided in mould to form the buttons, in order to fill them, carefully re-filling the holes thus made with fresh clay.

Taking the clay cutting bow, he draws it along the tile mould lengthways, commencing from the button end, thus taking off the two pieces which project above the sides of the mould.

He now puts one end of the wire cutter (*Fig. 3, Plate XXV.*), against the inside of the vertical guide (C), (*Fig. 3, Plate XXVI.*), at one end of the mould, and straight along the tile mould down to the vertical guide at the other end, forcing the wire down until it rests on the top of the horizontal guides (Q), (*Figs. 3 and 6, Plate XXVI.*), he then draws it across the mould on the horizontal guides, and up against the opposite vertical ones, and in the last operation the moulder places one hand on to the clay to prevent the wire lifting the clay out of the mould.

The pieces of clay thus cut off are taken out of the mould in a roll, and thrown back on the kneading board, which has previously been re-sanded, or thrown in a heap on one side to be re-pugged before being again used, and this is the most advisable course to follow, in order that the sand that may adhere to the clay be properly amalgamated with the clay before it is used again. Thus the clay formed in the proper shape of the tile is alone left in the mould, and should any small holes appear on the surface of the tile they are carefully filled up with fresh clay; the moulder then takes the strike out of the water box, taking care to see that it is perfectly clean; holding the strike in his left hand, he sprinkles a little water on the tile with his right hand, and then runs the strike backwards and forward and up the sides to give a smooth surface to the tile, and if after this there is any excess of water on the tile, he wipes it off with a piece of flannel. No more water should however be used than is necessary.

He now dries his hands, and taking the handle of the fork with his right hand, raises it from the body of the mould (keeping the latter down on the



table with his left hand), until it is clear of the pin at (K), (*Plate XXVI.*) which secures it.

He then gently draws it with the tile on it out of the mould and carries it to the shelf.

He then gives the fork a slight jerk which projects the tile about an inch beyond the end of the fork; he next rests the end of the tile on the shelf, and puts a small piece of wood at the back of the tile so as not to touch it with his fingers, and withdraws the fork leaving the tile on the shelf; the buttons should not touch the shelf.

He now takes the fork back to the mould, sands it again, and proceeds with another tile in the same manner as before; a good moulder can mould 100 flat tiles in a day, but on the average 75 per man is the quantity turned out.

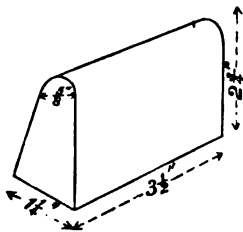
The tile having been put on the shelf, is left there until it is sufficiently dry (from 24 to 36 hours after being moulded) to bear handling, after which it has to go through the operation of "dressing."

To dress the tile, the moulder takes the dressing block, dresser, and knife, near the row of tiles, which have to be operated upon, and places the block on the floor of passage, and next taking up a tile puts it into the dressing block, and if it will not go in level with the front of the block, the end of tile must be tapped and pressed in with the dresser, (*Figs. 7, 8 and 9.*)

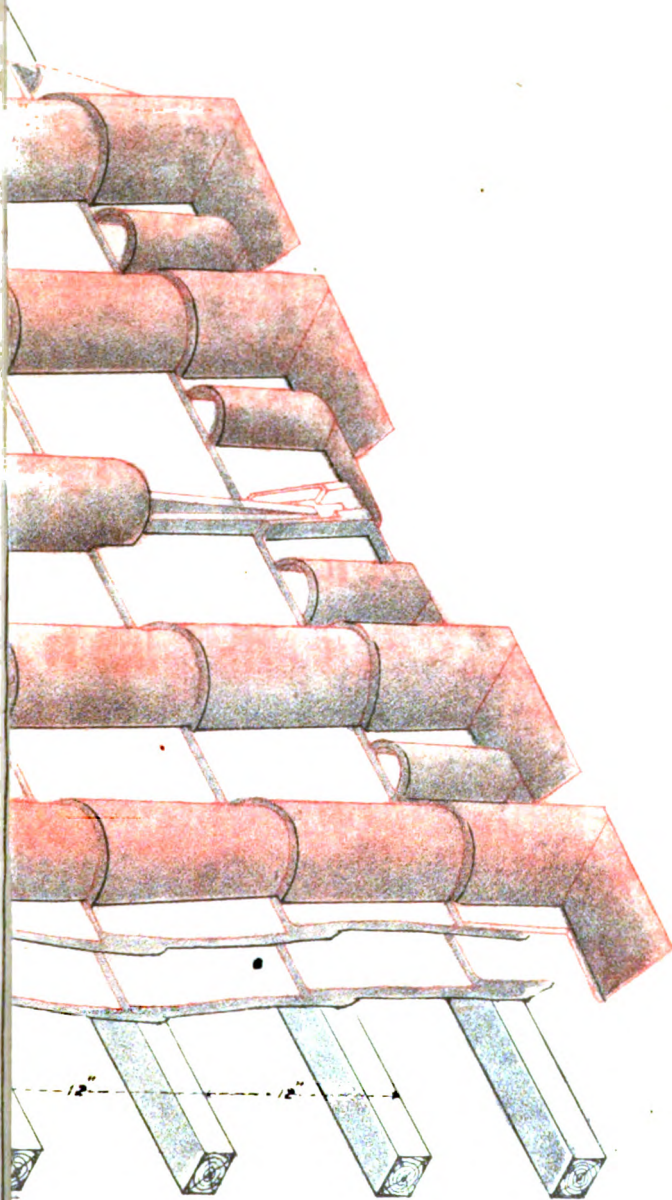
He then gives the top of the tile three or four equal and even blows with the flat side of the dresser, taking great care that all the blows are equal, as otherwise the tiles twist from unequal dressing; he next smoothes the surface with his hands, and with the dressing knife he pares over the sides to take off extra clay, doing the same to the two ends, and to the inner surface of the sides also if they require it, after which he smoothes the surface with the outside skin of a small piece of bamboo or with a small piece of wood, the bottom surface

of which is smooth and polished.

He then with the point of the knife makes the drip channels as shown in the tile, (*see A, Fig. 13*) about  $\frac{1}{4}$ -inch deep. These drip channels are intended to collect any rain water that may be driven under the tiles by high wind, and carry it off in proper direction.



TILE MANUFACTURE-ALLAHABAD.





D.

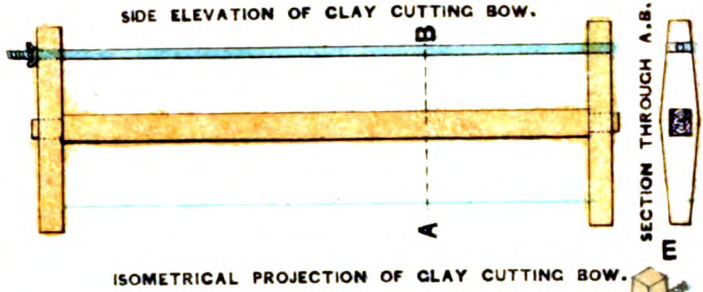
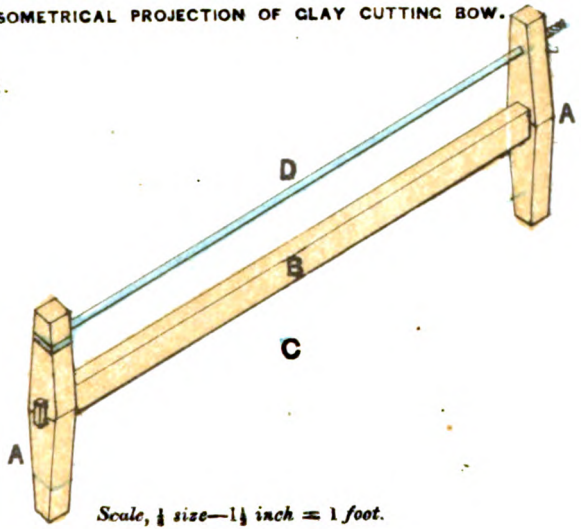
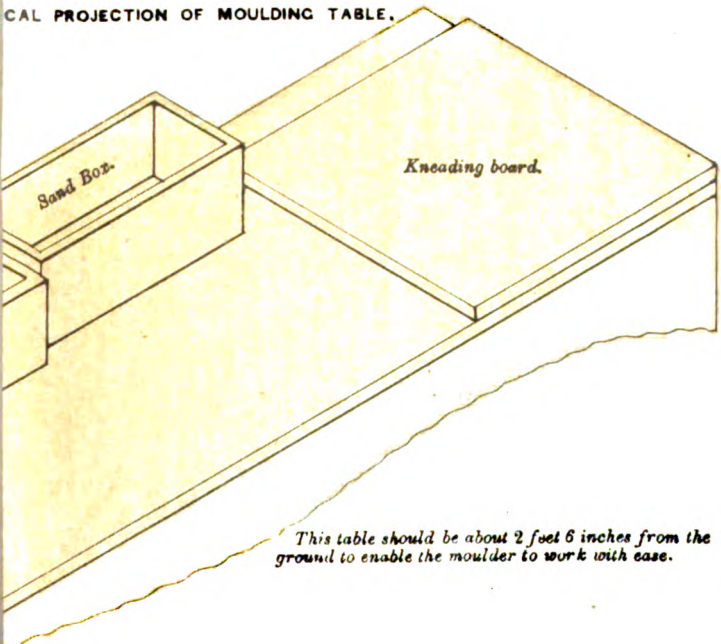


Fig. 3.



Scale,  $\frac{1}{4}$  size— $1\frac{1}{2}$  inch = 1 foot.

ICAL PROJECTION OF MOULDING TABLE.



This table should be about 2 feet 6 inches from the ground to enable the moulder to work with ease.

$\frac{1}{2}$  size— $\frac{1}{2}$  inch = 1 foot.



3AD.

FORK OF PLAT TILE MOULD

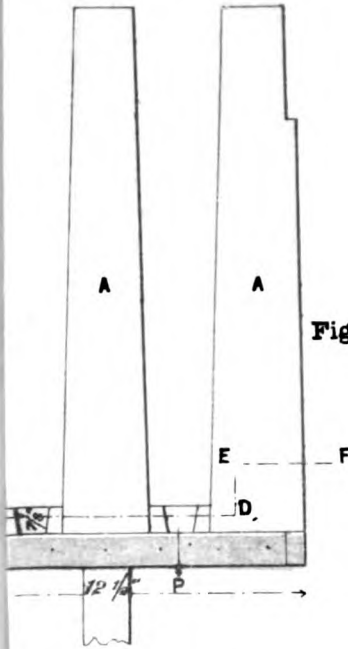


Fig. 4.

SECTION THROUGH ABCDEF.

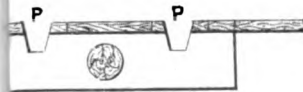


Fig. 5.

METRIC PROJECTION.

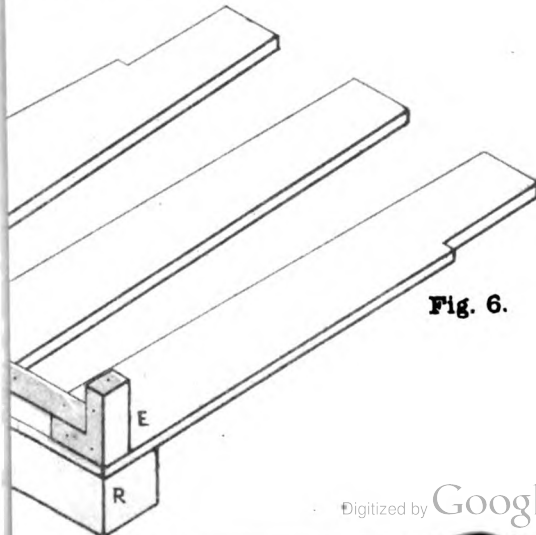


Fig. 6.



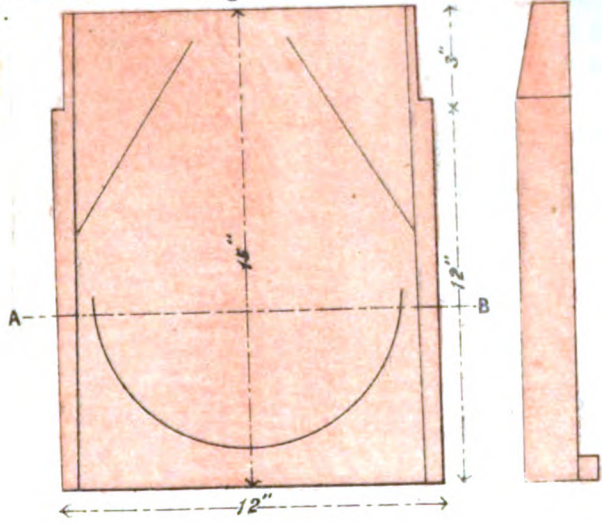


BAD.

SECTION THROUGH A-B.  
Fig. 5.



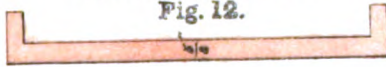
PLAN OF FLAT TILE.  
Fig. 11.



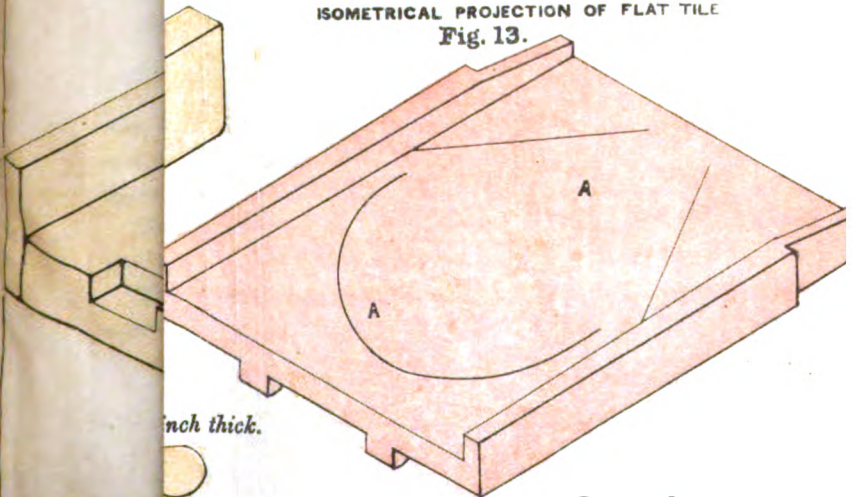
SECTION THROUGH A-B.  
Fig. 8.



SECTION THROUGH A-B.  
Fig. 12.



ISOMETRICAL PROJECTION OF FLAT TILE  
Fig. 13.







The tile is now taken out of the dressing block by a piece of wood being placed at the tail end, and pulled towards the moulder; it is then returned to the shelf where it is left to dry, as if taken out to dry quickly in the sun it will twist and warp. The tile is carried to and from the dressing block in the moulder's hands.

When dry the tiles are stacked upright in rows. They are put out into the sun on fourth day in hot, and sixth day in cold, weather. This is done for one, or at most two consecutive days immediately before the tiles are kilned and at night they should be carried back, and stacked inside the shed to prevent their being exposed to dew, &c.

The complete tile is shown in plate.

If the tile is to be used with the semi-hexagonal which has two side lugs, (Plate XXXIV., Fig. 3,) and which is the tile now adopted at Allahabad, the position of the buttons must be arranged to fit on to the lugs, this can easily be done, and requires no radical difference in the mould or moulding.

**HALF ROUND TILES. The Mould.**—The mould consists of a block of sál wood divided longitudinally and horizontally into two parts, the upper and lower; this mould is of the exact form of the inner or concave surface of the tile, and at each end of it is placed an upright piece of wood or guide to give the thickness of the tile, one guide is fixed to the bottom or body of the mould, and the other to the upper part or fork, to which also a handle is attached, so that it can be lifted off with the tile on it. Knotches (AA) are cut to form the buttons, and two pieces (BB) are screwed or nailed on to form the recess at the lap or tail of the tile.

**Strike.**—The same strike as for a flat tile is used, and if a bevelled lip is required, the strike shown in Figs. 4 and 5, is also used.

**Dressing Block.**—The dressing block, (Fig. 3,) for the half round tile consists of a piece of sál wood, hollowed out to the exact form of the outer or convex side of the half round tile, it is hinged on to the edge of a table, and is provided with a handle on one side; this arrangement admits of the tile after it is dressed, with a fork inserted, being turned over for the purpose of being carried back to shelf.

**Dresser.**—The dresser of sál wood is a block cut to correspond with the inside of the tile, see Figs. 4 and 5.

**Moulding the Tile.**—The moulder treats the clay in exactly the same manner as for a flat tile, and puts it on to the mould in like manner, tak-

ing care to strike it from the top downwards, so as to tighten it over the mould, and leave no space at the top between the clay and the mould, he then presses his thumbs into the buttons as for flat tiles, and makes good the holes by adding fresh clay.

He then takes the clay cutting bow, and holding it parallel to the sides of the mould, presses the wire down to the top of the end vertical guides, and draws the wire from the top downwards, one side at a time, the pieces thus cut off are thrown back on to the kneading board; a small strip of clay is left standing at the crown of the tile.

He then strikes the tile with the flat side of the strike, (*Plate XXVII., Fig. 4.*) but working it from top to bottom on each side, instead of backwards and forwards as for a flat tile, and if a bevelled edge is necessary, the strike (*Plate XXVIII.*) is used, to give the bevel after the tile has been smoothed with the ordinary strike.

The tile is now taken away on the fork (or upper part of the mould) which lifts off, and it is placed on the shelf. To do this no jerk is necessary, the depth of the fork being less than that of the tile, the latter is gently laid down, the fork is then dropped and removed, which can be done without touching the tile.

The shelf for half round tiles must be provided with strips of wood  $\frac{3}{4}$ -inch thick, and about one inch broad, to form a rest for the tail of the tile where notched out.

When ready for dressing, *i. e.*, when sufficiently dry to bear handling, the tile is put into the dressing block with the concave side of tile upwards, the dresser is then inserted and firmly pressed down, receiving two or three taps with a mallet, it is then taken out, and the extra clay projecting beyond top and ends of dressing block is pared off with the dressing knife; a fork (*Plate XXVIII., Fig. 3*) is now placed upside down in the tile and the dressing block, (which as above-mentioned is hinged to a table,) with the tile and fork in it is gently turned over, and the tile is taken back on the fork to the shelf to dry. *Plate XXIX.* shows the finished tile with two buttons. As it is desirable that the convex surface of the semi-cylindrical tile, which is exposed to the action of the weather, should never be sanded, but have as smooth a skin as possible, the concave surface of dressing block is oiled before the tile is inserted and no sand is used in this process. About two pounds of oil are expended by seven moulders per diem.

The tile can also be made with one button at the top. The plate shows this tile and the fork required for moulding it, but the introduction of the double button is considered a great improvement. *Fig. 8* shows another tile lately designed to suit localities where high winds are frequent, the ridge and eave tiles being laid in mortar, the rest cannot be lifted up.

The plate shows the form of the curves at each end of the dressing block.

**SEMI-HEXAGONAL TILES.**—Two moulds are used successively for this tile: the first one consists of a slab of wood about 2 feet

**PLATE XXXI.**  $\times$  1 foot 3 inches with another slab in the centre of it, and raised  $\frac{1}{4}$ -inch above it; on to this is placed a frame one inch thick so that it projects  $\frac{3}{4}$ -inch above the raised slab of the mould; this mould is then filled with clay which is struck off roughly with the clay bow, and the surface dry sanded, thus the superficial area and thickness of the clay required for making the tile is obtained.

The cake of clay is then taken out of the frame by two men, one at each end, and put into the second mould, which consists of a block of wood hollowed out in a semi-hexagonal form to the shape of the outer or convex side of the tile; this block mould is hinged on to a solid block of timber built in masonry.

Sockets are cut out of the mould to form lugs, which may be placed in the position considered most advantageous.

**PLATE XXXII.** The projecting portions (A) of the mould form the socket for the lap of the tile.

The clay having been put into the hinged block mould, is now beaten out into the angles with the hand. The clay is pressed into the sockets with the thumb to form the lugs, and extra clay is added to fill up the holes thus formed; after this the press, fitting exactly to the form of the inside of the tile is brought down by means of a lever on to the guides B provided at ends of the block mould, and which are at such a height above bottom of mould as is required to give the thickness of the tile.

The press (D), is of the form of the dresser shown in *Plate XXXIII.*, but lengthened so as to fit into the guides B, the lever and press must be fixed very strongly and carefully, and must come down in the exact position required. After being brought down, three or four blows with a mallet are struck on the top of the lever (which should be armed with plates of iron to protect the wood) until the press is driven home into the guides

(BB), the lever is then thrown up, and the excess of clay projecting at sides and ends cut off with a clay bow.

The fork, made similarly to that of a half round tile fork, but semi-hexagonal in form, is now put upside down into the tile, and the moulder taking the handle of the tile mould with his left hand

PLATE XXXIII. turns it (with the tile and fork in it) over; before the block has made the complete turn, the moulder drops the handle of the mould, and grasps the handle of fork with both hands, and lets the whole down without a jerk. He then lowers the fork, and the tile comes on top of it.

He then puts the tile into a rack or on a shelf provided with a strip of wood as for a half round tile, to dry, and when dry enough to be handled, dresses it in same manner as a half round tile is dressed; the dresser and dressing block used being of semi-hexagonal shape. Sand and not oil is used in the dressing block for semi-hexagonal tiles, which are rarely, if ever exposed, to the weather when laid on a roof.

The complete tile without lugs is here shown; also the lugs in four different positions. The tile with two side lugs shown PLATE XXXIV. in *Fig. 3*, is the one now adopted, as it is considered the best.

RIDGE TILES (*plain and ventilating*). *The Mould*.—The mould as for half round tiles is made in two portions, an upper and a lower; each

PLATE XXXV. consists of a block of sál wood with mango wood end, the top edge of which is plated with sheet iron, the two plain surfaces meet at the angle to which the roof is to be pitched. Four pieces of wood (A), *Figs. 1, 2, 3 and 4*, are affixed to form the recesses where the tile laps over the flat tile. The fork or upper part of mould to which a handle about one foot long is attached takes out of the body of the mould, in order that the tile may be lifted up as is done with the flat and half round tiles.

*Block*.—The block consists of any common wood that does not twist, and is of the form shown.

*Strike*.—The strike for this tile is different from those in use for the flat and half round tiles, and is of the form shown in plate, about 1

PLATE XXXVI. foot 9 inches long by 1 × 2 inches; there is a jaw at each end (AB), and the distance from (a) to (d) is but a trifle longer than the breadth of the tile mould measured from

the outer edge of one end, to the outer edge of the other, the projecting ends (EF), form handles, and act as guides, and run along the outer edges of the tile mould.

The jaws (AB) of strike, regulate the thickness of the raised edges of the tile, while the thick part of the strike from (b) to (c) takes out the clay in the centre part of the tile, leaving the necessary thickness only.

*Moulding the Tile.*—The clay is put on to the mould as for a half round tile, and well beaten with the hands and pressed into the corners; the moulder then takes the clay bow and cuts off the excess of clay, working from ridge downwards, the wire resting on top of end pieces CC, (*Figs. 2 and 6, Plate XXXV.*), which are respectively attached to the lower and upper portions of the mould—this surplus clay is then removed. The moulder now places the wire parallel to the side pieces (CC) and judging the thickness of clay necessary to form the sides of the tile and that to be left at the crown, dresses the wire down through the clay until it rests on the top of guide B, (*Figs. 1 and 2*), he then draws the wire across the mould to the other side, and again judging the thickness of clay required for the sides he draws the wire upwards, at same time holding down the clay with one hand to prevent its lifting out. The extra clay is then rolled off and the other side of mould is treated in same manner.

The moulder then sprinkles the surface of the clay with water, and strikes it from top to bottom with the strike already described; the clay on top of side pieces A, which it will be observed are not parallel to top of side pieces C, is removed with a small piece of wood, thus leaving the clay of the shape of the tile in the mould; after this he sands the tile, and taking the drying block, inverts it and puts it on to the top of the tile, he lifts the fork out of the body of the mould, and turning the whole upside down, leaves the tile on the block. The reason for inverting when drying, is to prevent the clay tearing, which takes place when dried the opposite way.

When hand dry, the tile is taken off the block, dressed with a knife, and then stood on end; if to be only a plain ridge tile it is now in a finished state, but if to be a ventilating ridge tile, there is another process before the tile is complete, which consists in adding a ventilating pipe.

*Ventilating Pipe.*—The ventilating pipe is formed by two semi-cylindrical pieces of clay about two inches wide meeting at same angle as the ridge, and which are moulded in the same manner as a half round tile;

the mould is shown, and the end (A), *Figs. 2, 3 and 4*, instead of being vertical as in a half round tile, is slanting to give the

**PLATE XXXVI.**

angle at which the two pieces meet; after moulding, these semi-cylindrical pieces of clay are not dressed, but left to stiffen, the plain ridge tile and the two semi-cylindrical pieces of clay which are to form the ventilating pipe have then to be joined together as follows :—

When they are all in a state sufficiently stiff to be handled, a ridge tile is removed from the drying block, and taken to the table and placed

**PLATE XXXVII.**

on another block, but in this operation the tile is not reversed, but placed in its natural position (one of these latter blocks only is required per moulder as the tile is removed as soon as finished); any sand which there may be on the tile is now removed with a knife, and then having placed the semi-cylindrical pieces of clay on top of ridge tile in the position they are intended to occupy, their place is marked on the ridge tile with the point of a knife, the moulder then cuts grooves about  $\frac{1}{8}$ -inch in depth out of the ridge tile, and of sufficient breadth for the lower edges of the semi-cylindrical pieces of clay to fit into.

The lower edges of the two semi-cylindrical pieces of clay are then jagged with a knife, and they as well as the grooves cut in the ridge tile are moistened with water; small quantities of extra clay are then put on to the upper ends of the two half pipes to ensure a good joint at the apex, and the two pieces are then worked and pressed down into their places, and the side joints worked over with the knife to ensure perfect fit; sausage-shaped pieces of clay are then placed over the side joints on the outside, and smoothed off with the hands. Care must be taken that the half piping, the ridge tile, and the extra clay, used are all of the same consistency, otherwise they will separate one from another, either in the drying or burning.

Either a few jags or a small bar of clay may be put on the ridge tile under the ventilating pipe, to prevent any spray being driven up the pipe; but though tried last year without these additions, no drift leakage took place.

Before the half piping is added to the ridge tile, a hole as shown at (A), *Fig. 2*, is cut out in the centre of the crown of the tile with a circular tin cutter, to the size required, about  $2\frac{1}{4}$  inches. *Fig. 3* shows a finished ventilating ridge tile.

**HALF ROUND RIDGE TILES.** *The Mould.*—The mould consists of two blocks of sál wood, hollowed out to the form of the outer surface of the tile; these two blocks are joined with a hinge and fastened up by means of the hook-and-eye at (A), *Fig. 4.* The two ends of the tile mould are raised to give the thickness of the tile *see* (B), *Figs. 3 and 4.* The drying block is formed of two plain pieces of wood about eight inches long and meeting at the same angle as that of the flat ridge tile, the block shown, *Plate XXXV.*, can also be used. The strike is of the form shown. The two pieces (B) at the ends act as handles and as guides, running along the outside of the mould, and the semi-circular portion at (A) takes out the clay in the centre of the tile, and the spaces between the jaws of the strike and the mould give the thickness of the tile. *Fig. 7* shows the curve at half size at A.

*Moulding the Tile.*—The mould is filled with clay, and the excess at the ends of the tile mould is taken off with a clay bow, the excess thickness inside is then taken out with the fingers, care being taken to leave an ample quantity for the thickness of the tile.

The tile is next struck from end to end, the strike acting in exactly the same manner as for a plain ridge tile.

After the tile is struck, an inverted drying block is put into the mould, and the whole is turned over, the mould is now opened by loosening the hook at (A), and carefully taken off—the tile being left to dry. When dry enough to be handled, it is dressed with a knife. The plate shows the finished tile.

**HIP TILE.**—*The Mould.*—The body of the mould consists of a block of wood as shown, into this the tray or fork fits, upright guides fixed at the ends on the lower half of mould, and at end of upper half or fork, give the thickness of the tile, *see* (A).

*Block.*—The block consists of two planes of wood meeting at the proper angle.

*Moulding the Tile.*—The tile is moulded exactly the same as for a half round tile, but instead of being dried on a shelf, each tile has a separate block on to which it is slid, as a flat tile is on to its shelf—this block is wetted and sanded before use.

When stiff enough to be dressed, the tile is not removed, but the dresser of the same shape as for a flat tile is put over it. It is then smoothed



with the hand, the edges are trimmed with a knife, and it is left to dry. The plate shows the complete tile.

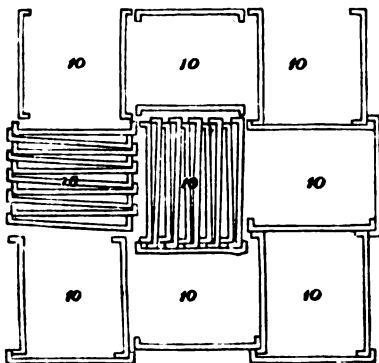
**HIP CAP TILE.**—The hip cap tile consists merely of two portions of a hip tile, and is made by cutting two hip tiles after they are moulded, until their respective surfaces meet at the required angle, these two are then joined together as follows:—

A drying block is made to the form of tile required. The ordinary hip tiles when fit to handle are cut to the angle required, and after adding some extra clay to the edges that are to be joined, they are put on this block, and the edges joined by forcing them together with a knife or the fingers, care being taken to ensure perfect amalgamation, the holes made by the fingers or knives are filled up with extra clay of the same consistency as the tile.

**II. LOADING OPERATION.**—The kilns are loaded with bricks as described in the report on Brick manufacture, to such a height as will admit of two layers of tiles being placed at the top, below the covering course of flat bricks.

The tiles are then loaded as follows:—

All round the sides of the kiln half round and semi-hexagon tiles are placed, usually in two or three rows, but if more are required they can be put in. The side and end spaces for fuel at top of kiln, as described in the report on Brick burning, must be left in doing this. In the centre,



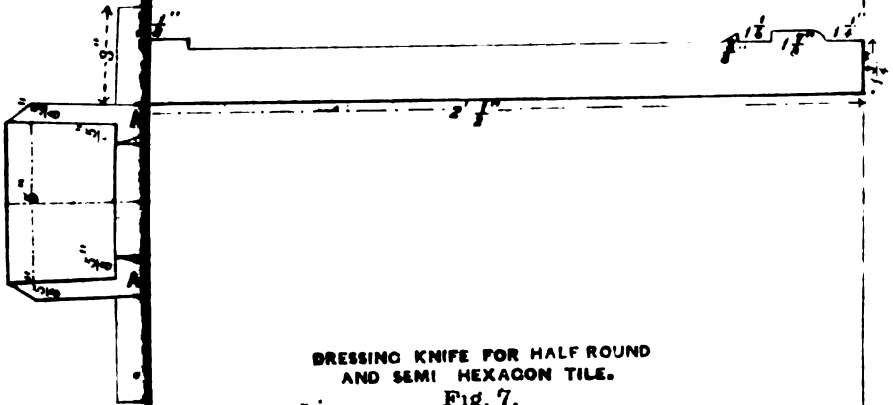
the flat tiles are placed in squares of 10, all the tiles are set on end, and

BAD

PLAN OF

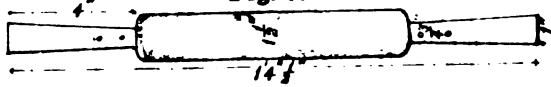
ELEVATION OF STRIKE FOR GIVING A BEVELLED EDGE.

Fig. 4.



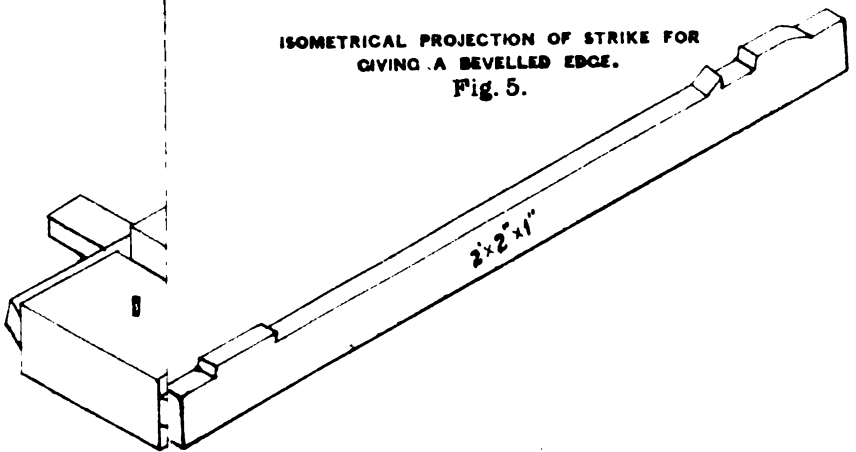
DRESSING KNIFE FOR HALF ROUND AND SEMI HEXAGON TILE.

Fig. 7.



ISOMETRICAL PROJECTION OF STRIKE FOR GIVING A BEVELLED EDGE.

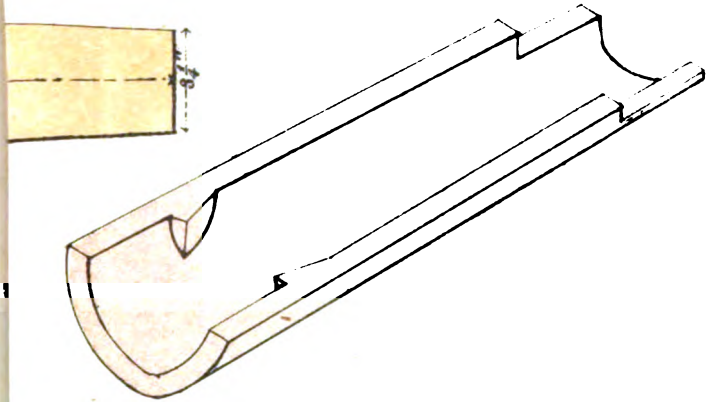
Fig. 5.



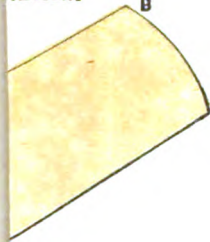


ABAD.

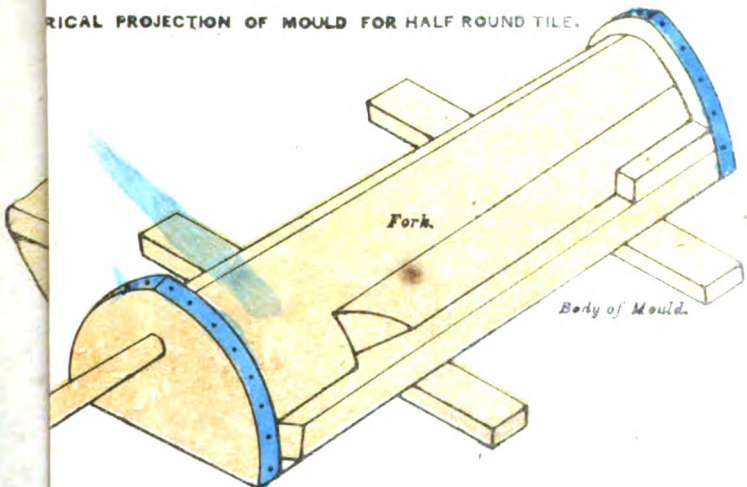
OND TILE. ISOMETRICAL PROJECTION OF HALF ROUND TILE WITH TWO BUTTONS TURNED UP SIDE DOWN.



RESSER. B



ISOMETRICAL PROJECTION OF MOULD FOR HALF ROUND TILE.

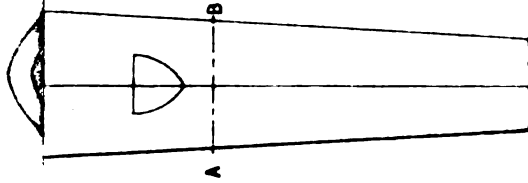




CROSS SECTION THROUGH A-B.

D.

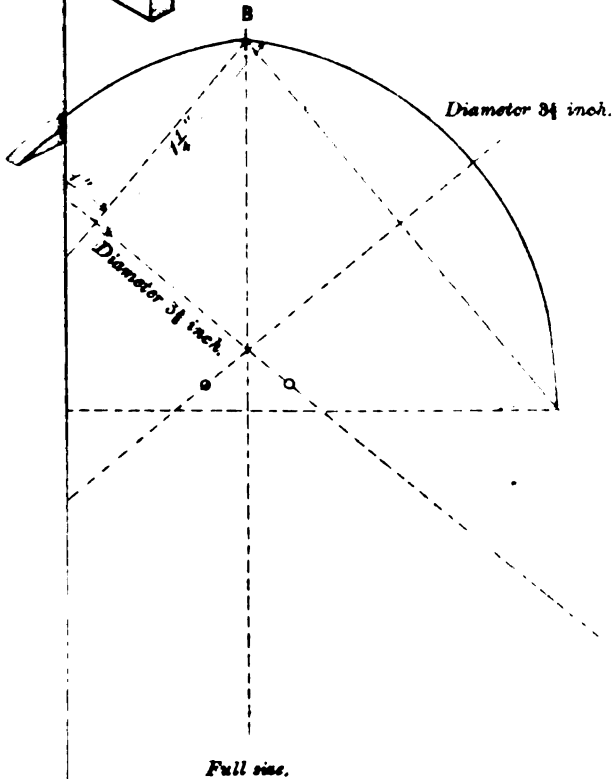
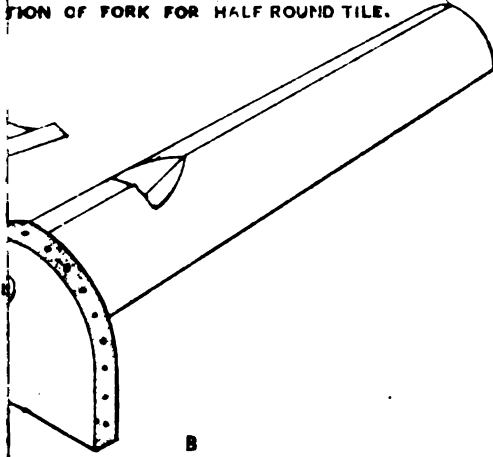
AN OF FORK FOR HALF ROUND TILE.  
WITH SINGLE BUTTON.



CROSS SECTION THROUGH A-B.



SECTION OF FORK FOR HALF ROUND TILE.



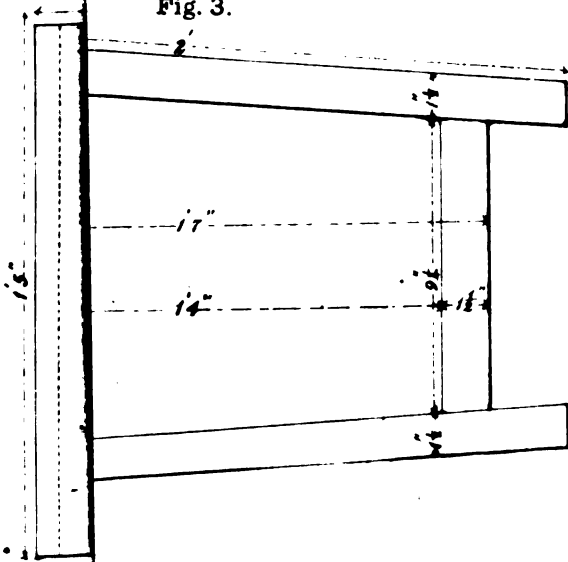
Full size.



D.

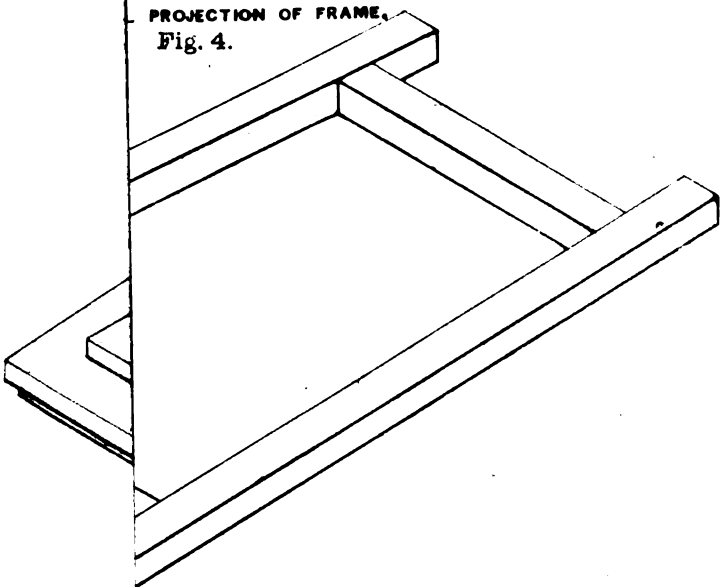
ED FOR MOULDING SEMI HEXAGON TILE.

Fig. 3.



PROJECTION OF FRAME.

Fig. 4.



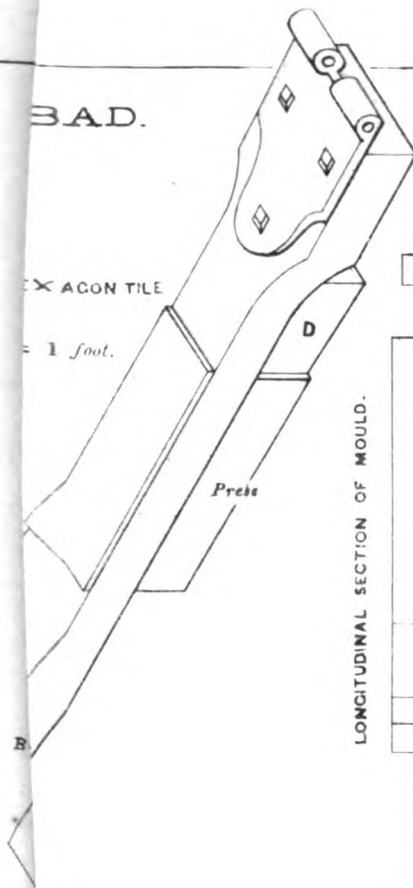




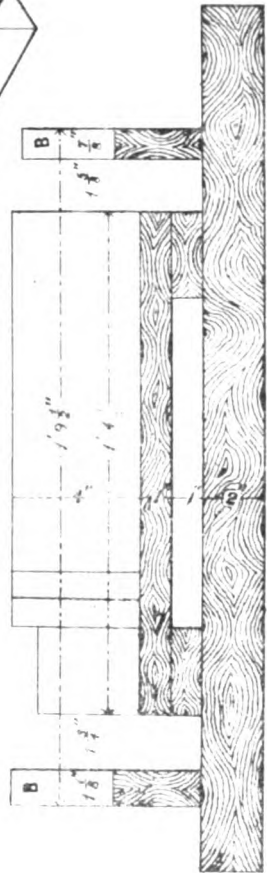
SAD.

X ACON TILE

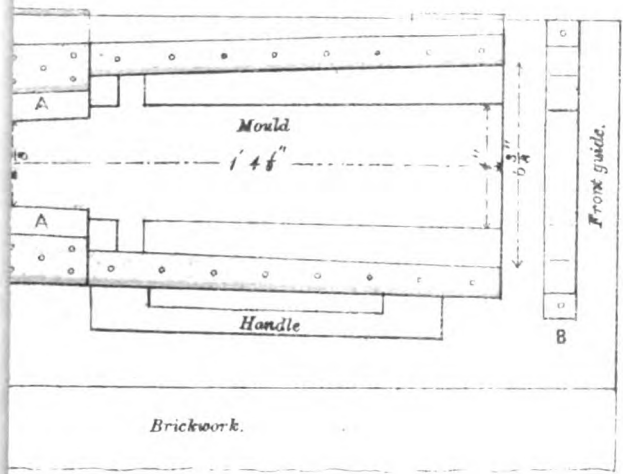
1 foot.



LONGITUDINAL SECTION OF MOULD.



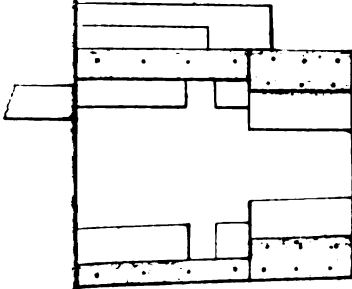
s,  $\frac{1}{8}$  Full size—2 Inches = 1 Foot.





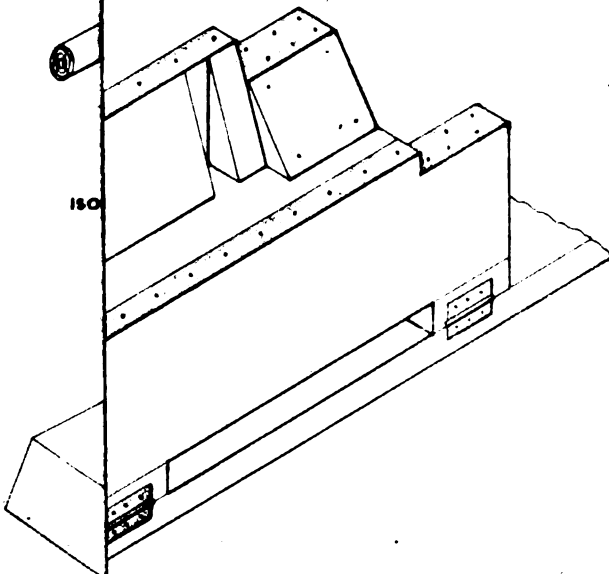
D.

DRESSING BLOCK.



B.

SECTION OF DRESSING BLOCK.



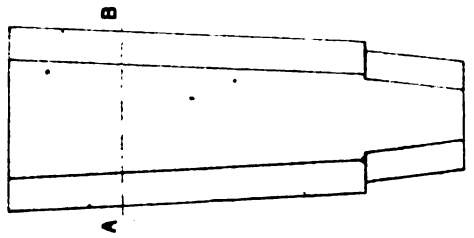


LABAD.

ACC.



PLAN OF SEMI HEXAGON TILE.



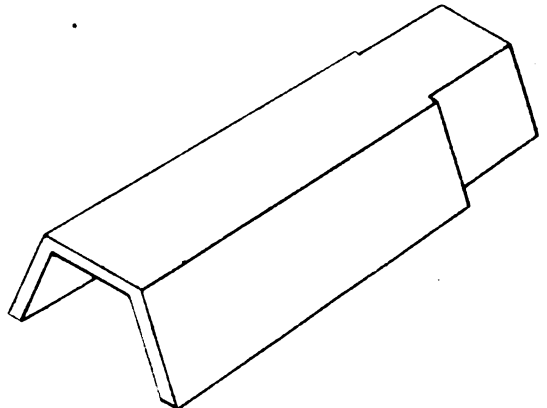
SECTION THROUGH A.B.



SIDE ELEVATION



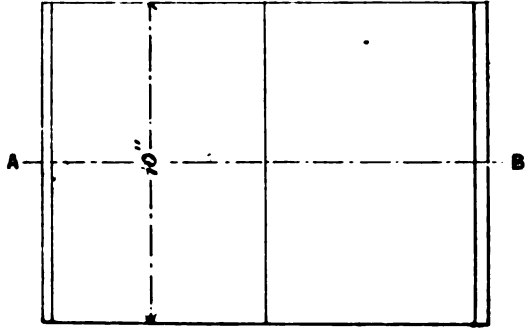
ISOMETRICAL PROJECTION OF THE SEMI HEXAGON TILE.



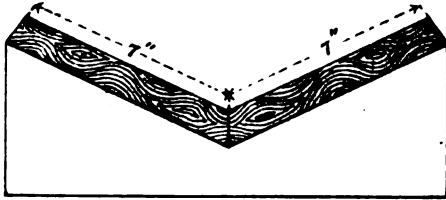


D.

PLAN OF DRYING BLOCK FOR R'DCE TILE.

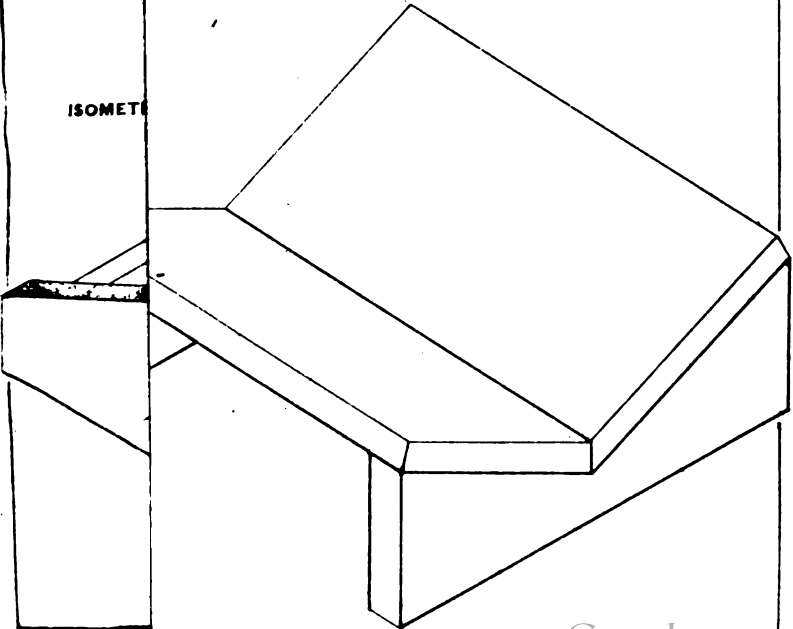


CROSS SECTION THROUGH A.B.



ISOMETRICAL PROJECTION DRYING BLOCK.

ISOMET

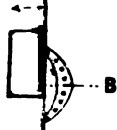






BAD.

VENTILATING RIDGE PIPE.



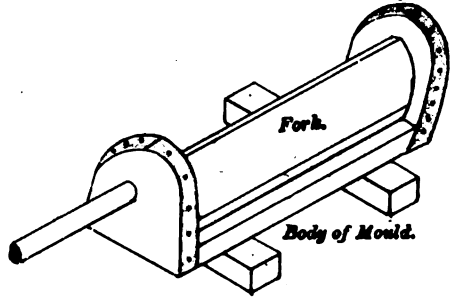
PLAN OF FORK FOR VENTILATING RIDGE PIPE MOULD.



RIGHT HAND SIDE A.B.



ISOMETRICAL VIEW MOULD COMPLETE.

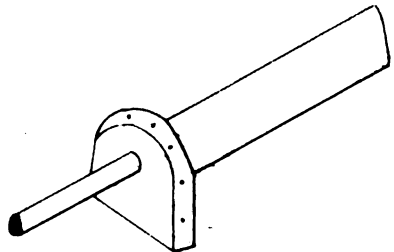


D.

MOULD.



ISOMETRICAL PROJECTION OF FORK.

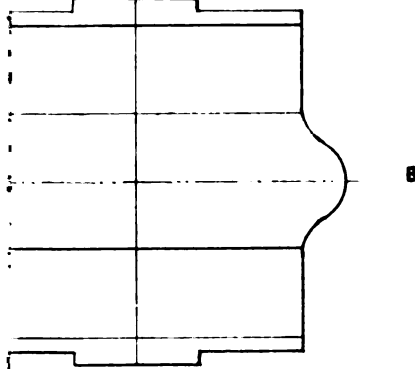




BAD.

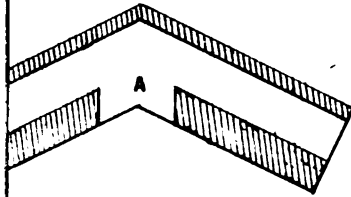
SECTION OF VENTILATING RIDGE TILE.

Fig. 1.



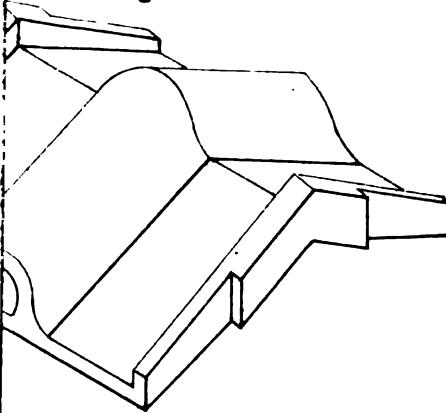
LONGITUDINAL SECTION THROUGH A.B.

Fig. 2.



PROJECTION OF VENTILATING RIDGE TILE.

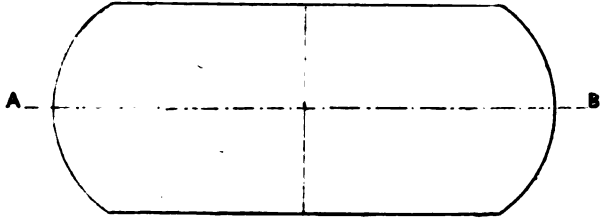
Fig. 3.



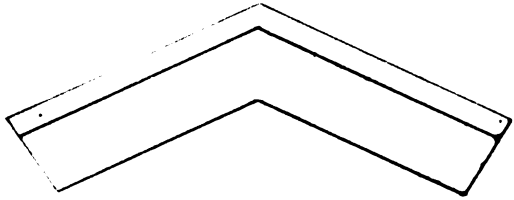


HABAD

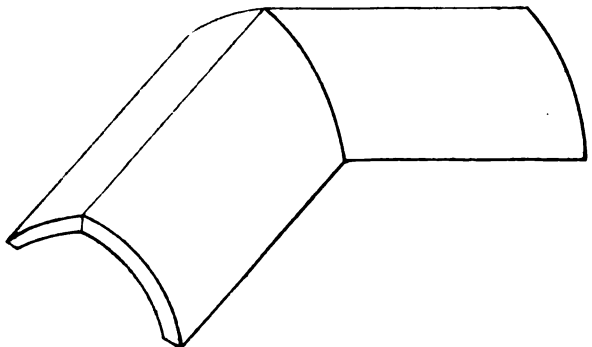
PLAN OF HALF ROUND RIDGE TILE.



LONGITUDINAL SECTION THROUGH A.B.



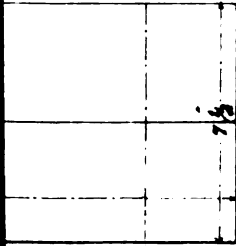
ISOMETRICAL PROJECTION OF HALF ROUND RIDGE TILE.





L.B.A.D.

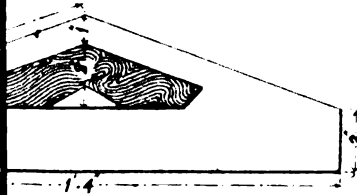
LE MOULD. B



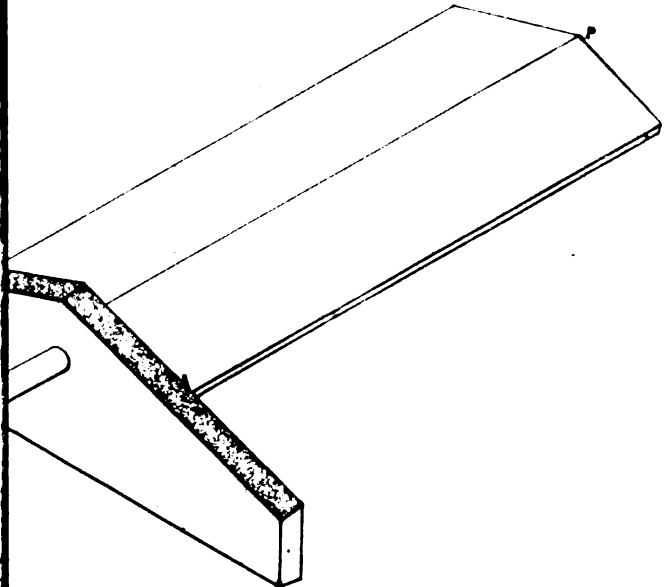
CROSS SECTION THROUGH A.B.



VIEW FROM P.



ISOMETRICAL PROJECTION OF FORK.

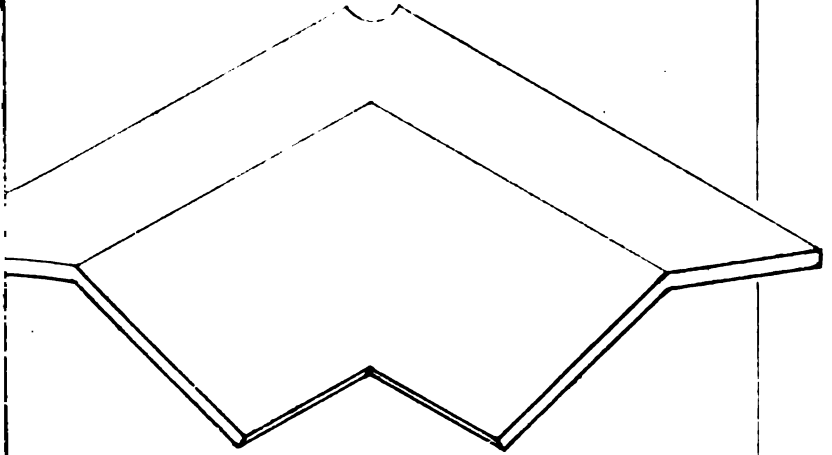




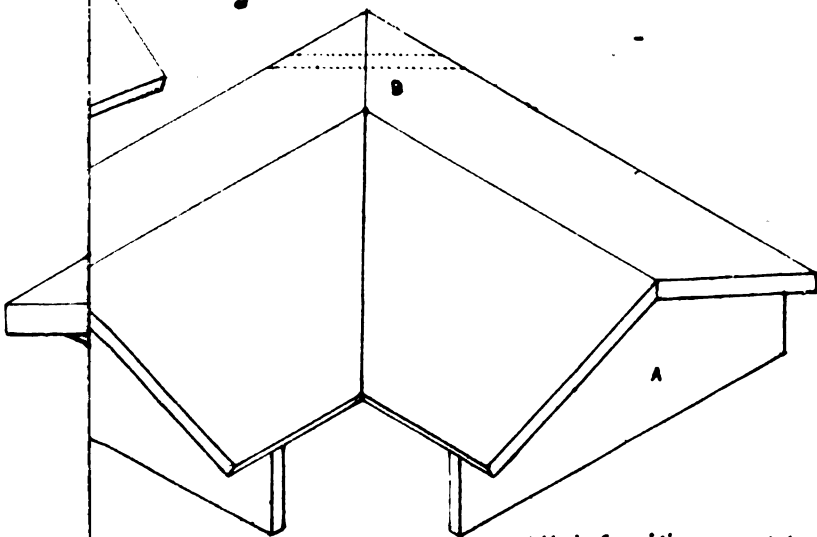


HABAD

PROJECTION OF THE HIP CAP.



BLOCK FOR DRYING HIP CAP ON.



*A block of wood the same as at A,  
A is fastened under the block  
at B*





the flat tiles in upper course are set across those on the lower. Over the tiles a flat course of bricks is put on as for Brick burning.

III. FIRING OPERATION.—The firing is the same as in Brick manufacture; cylindrical pipes should always be used on top of kiln for air flues.

All sorts of tiles can be burnt in the large kilns with the bricks, but at Allahabad there is a small round kiln in which all except flat, half round, and semi-hexagon tiles are usually burnt.

This small kiln has a domed roof, it is filled with bricks up to about three feet over the fire-hole, and the rest of the space is filled with tiles three or four deep, instead of two only as in a large kiln, the kiln only takes seventy-two hours to burn.

IV. RATES AND MISCELLANEOUS.—The rates paid at present to contractors are as follows :—

Flat tiles, .. .. .	Rs. 10 per 1,000.
Semi-hexagon, .. .. .	" 8 "
Half round,.. .. .	" 6 "
Plain, hip, and half round ridge tiles, .. .. .	" 15 "
Ventilating ridge tiles, .. .. .	" 30 "

Payment is only made for serviceable materials turned out of the kilns of first and second class, and the rate includes the following operations :—

Preparation of clay—Moulding—Loading—Unloading—Firing (labor only)—Repairs to sheds—Repairs to kiln, &c.

Moulds and tools are supplied to Contractor, and the sheds and kiln put in order at the commencement of the season Departmentally.

G. P. DEP. F.

---

No. CXVI.

---

ON THE DESIGN OF WROUGHT-IRON GIRDER  
BRIDGES ESPECIALLY IN REFERENCE TO  
THE INDIAN METRE GAUGE RAILWAYS.

[ *Vide* Plate XL ]

---

By C. H. G. JENKINSON, Esq., A.I.C.E., *Assoc. King's College,*  
*London, Assist. Engineer, Western Rajpootana (State) Railway.*

---

CONSIDERING the high cost of iron; the necessity for its large use for Railway bridges; its weight, and the consequent cost and difficulty attending its transport, it becomes the duty of engineers to consider how to employ this most necessary and costly material to the best advantage. In other words how to build bridges which shall carry the given loads at the least expense of iron.

It is not intended here to discuss the relative advantages of long and short spans: that can only be profitably done for particular cases, as so many local circumstances must weigh in the argument; and no engineer would ever adopt a long span where he could profitably use smaller ones. But we propose to discuss the relative advantages of the different forms of girder for bridging a given span. We shall too be more interested with spans from 50 to 150 feet, as below that limit plate girders are more economically used; and beyond 150 feet the dead weight of the bridge is so much increased that many of the considerations governing as in designing smaller spans have not the same importance, and from the circumstances of the case the engineer is often limited in his choice of truss, so that no general rule can be laid down for his guidance.

The railways of India cross many broad rivers, and torrents which

require the provision of a large amount of waterway. Too frequently the beds of these rivers consist of sand to a very great depth, which is liable to be scoured out by the impetuous torrents which come down in the monsoons. Hence there is no security in the foundations of a bridge unless carried at great expense to a firm stratum lying below the shifting sands of the river bed, as many failures of bridges have lamentably shown. Therefore to lessen the expense of the foundations of the piers of the bridge, tolerably long spans are resorted to, for which we now wish to enquire the best method of design.

Now on the Indian railways we have to deal with an exceptionally light rolling load: and the problem before us is how to design bridges whose girders shall not have an excessive amount of material in any of their parts for bearing the light strains to which they are subject; and at the same time to produce a stiff bridge without an excessive amount of external bracing.

On examination of diagrams of strains calculated for girders of moderately long span to carry the light rolling loads\* laid down by the Government of India, and for a single line of way, it is evident that much material must be included in the design which is not required to resist the strain, and which cannot do much good in adding stiffness to the girder; it is therefore material out of place, and little better than dead weight. For instance, at the ends of the flanges of a parallel girder the strain diminishes rapidly, and in order to keep the width of the flange, and a sufficient thickness of material for workmanship, and endurance, the sectional area is necessarily made far in excess of requirements. Also it may be necessary to make the diagonals near the centre of the web of greater sectional area than the strain on them demands.

Here are points in the design which deserve particular attention; and, by the correct choice of the kind of girder to be used, this useless metal must be reduced to a minimum, or be brought into direct use as bracing, &c., and a stiffer, more efficient, and therefore more economical bridge will be the result for (at most) the same cost. As our trouble is that the strains to be met are too light for efficient and economical design, the first necessity is obviously to select a system of trussing in which the

\* One ton per foot run up to 50 feet, and 0.68 ton added for every foot after 50 feet on two girders. Thus the rolling load on one girder 100 feet span is

$$\frac{50 + 0.68 \times 50}{2} = \frac{50 + 33}{2} = \frac{83}{2} = 41\frac{1}{2} \text{ tons.}$$

strains are concentrated to the utmost and carried to the pier by as few members as possible.

No bridge that is not stiff can be economical. Vibration destroys not only the connections of the different parts of the girder, and shakes the piers, but by some process unknown to us, entirely alters the structure of the metal, making tough fibrous wrought-iron crystalline and brittle like cast-iron. Of course any amount of lateral stiffness may be attained by bracing on the platform, and between the girders. Bracing is of course always required, but the amount of it should be reduced to a minimum by providing a design already stiff in itself. Bracing is but a clumsy way of attaining the object; the stiffness of the bridge should not depend on the bracing but be supplemented by it. In bridges with the platform on the top of the girders it is possible to introduce vertical cross bracing between the main girders, which, with the platform, effectually ties the girders together; but when the road is between the girders, it is often difficult to sufficiently stiffen the top flange. Now, again, we are led to look to the concentration of strain in the flange to solve our difficulty.

In designing bridges for India other important considerations are, the carriage of the iron work from England to the port in India, and thence to the site of erection, probably by a not very excellent road in the common country cart: the want of skilled laborers as rivetters; and the inability of the people of India to handle heavy weights unless in inconveniently large numbers. Means must, therefore, be provided of dividing the girder into pieces of not too great a weight, and small enough for easy carriage.

Bearing in mind the preceding guiding principles in the design, let us enquire how to carry them out.

Taking the platform of the bridge first. The length of the bays of the main girders is decided principally by the depth and span of the girder. The length of the bay should decide the question of the distance apart of the cross girders of the platform; unhappily it does not always do so. It is not uncommon to see the cross girders of the platform placed at short intervals along the top or bottom flange of the main girder without any regard to the points of support to the flanges themselves. Such is a vicious design. Each cross girder truly is lightened by it, but it may be easily proved that cross girders placed at intervals of ten or twelve feet, being then over the supports of the flange of the main girder, with iron

rail bearers connecting them is a lighter construction of platform than more frequent cross girders.

The first lesson the designer of a girder should learn is to avoid subjecting any part of the girder to uncertain strains whose amount it is impossible, or at any rate useless, to calculate. Best avoid them, for already there is a large amount of uncertainty in the strain to which the members are subject, arising from accidents of workmanship, changes of temperature, and the like. Many will say that such considerations are superfluous; for is there not a "Factor of Safety"\* to provide for all our faults of design? Why should we load this "Factor" with all these encumbrances arising from the designer's negligence? Why should we not have as much of it as possible to the good? It was not invented by the Board of Trade to hamper enterprising engineers, and to be avoided if possible; but it was the result of a scientific investigation by eminent men, and is even lower in England than in some foreign countries. When all the unavoidable imperfections of the girder are covered by it there is still much left for it to do in supplying strength when the two great elements of destruction, vibration and rust, have been at work.

Now, consider the effect of loading the top flange of a main girder, say with bays twelve feet long, with a platform having cross girders only six feet apart. A cross girder then falls at the centre of the bay, and the flange is at once subjected to transverse strain, and may now be considered as a continuous beam, bearing at the same time a compressive strain throughout its length. In general the top flange, or compression member, is in shape a box with the under side omitted, with perhaps a stiffening piece of angle-iron riveted along the lower edges of the sides. This section is calculated to bear an uniform strain of four tons per square inch all over as a maximum. Now submit the flange to a transverse strain; and the effect must be to throw the line of compressive strain into a wavy line alternately approaching the top and bottom sides of the box, according as the tensile strain induced is at the top or bottom of the continuous beam—for it is evident that a tensile and compressive strain cannot exist at the same time in the same line—then parts of the section of the flange are compressed more than is desirable, or has been anticipated by the designer. Worse still to support cross girders at the centre of

\* In England one fifth to one-third of the breaking weight of iron, and in France one-fourth to one-third.



suspension links of which the tension member is sometimes composed. The advantage of continuity is here lost, and the whole tensile strain on the flange is thrown towards the edge of the bars. Failure from tension is more certain and rapid than from compression, and seldom gives warning beforehand.

Much of the stiffness of the bridge depends on the platform whether above or between the girders. The platform advocated, *i. e.*, Cross girders only at the points where the flange is supported by the web, and longitudinal rail bearers, all securely riveted together and to the main girders, and with the addition of horizontal cross bracing connecting the ends of, or points on, the cross girders certainly provides all that is needed in the platform to stiffen the bridge.

When the road is carried on the top of the main girders the trusses which suggest themselves as best fulfilling the conditions, for all except the longest spans under consideration, are those known as the Warren (*Fig. 1.*) and the Whipple Murphy (*Fig. 2.*)

As these two girders are in very general use, a comparison of the weights of their webs has been made; the result of which is that the weight of the Warren girder, assuming the flanges equal in both, is to that of the Whipple Murphy as 1 to 1.28. Though the top flange of the Warren has the lightest strain on it, yet, practically, it is only in the largest girders where any saving in metal would be made. No account has been taken of the extra bracing rendered necessary at the centre of the web by the rolling load, as it may be considered about equal in the two girders, the Warren having the advantage as the diagonals are shorter.

Hence we must conclude that for like conditions the Warren is the lightest truss; and though the Whipple Murphy bridge might, by lengthening the bays of the girders, be reduced to equal the Warren bridge, yet the more pleasing appearance of the Warren still gives it the preference.

But in the largest spans of which we are speaking, as the length of the bay of the Warren, with diagonals inclined at  $60^{\circ}$ , bears a fixed proportion to the depth, the length of the bay may be found too long. And, because the compression in the top flange is small towards the ends, it may be found impossible economically, and preserving an uniform strain per sectional unit throughout, to make the flange wide and deep enough to be sufficiently stiff in so long a column.

Fig. 5.

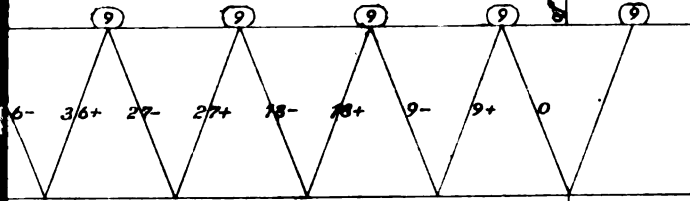


Fig. 6.

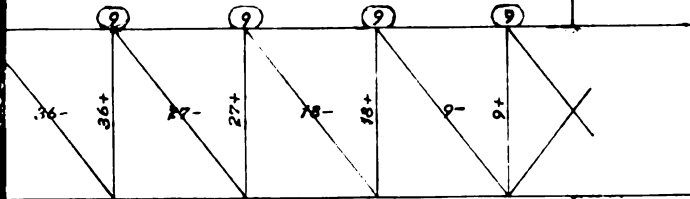
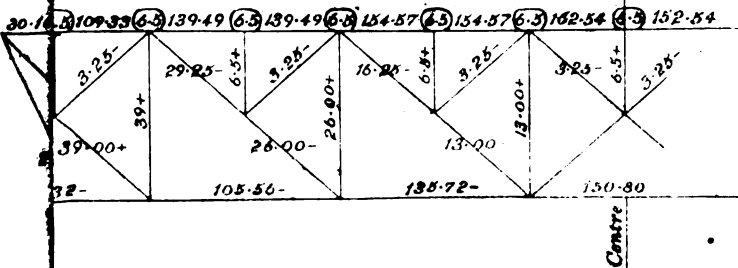


Fig. 6.





Comparison of weight between Warren and Whipple Murphy Girders, assuming that the weights of the flanges are equal: the corresponding struts and ties of each girder are subject to the same vertical strain S.

**WARREN.**

**WHIPPLE MURPHY.**

*Proportions.*

Depth of Girder, .. 1		Depth of Girder, .. 1	
Length of bay,.. .. 1.16		Length of bay, .. .. 1.16	
Length of diagonal, .. 1.16		Length of diagonal, .. 1.53	

*Ties.*

Number, .. .. 6		Number, .. .. 6	
Length, .. .. 1.16		Length, .. .. 1.53	
Total strain, .. S × 1.16		Total strain, .. S × 1.53	
Area, .. .. S × 1.16		Area, .. .. S × 1.53	
Contents, 6 × 1.16 × 1.16 S		Contents, 6 × 1.53 × 1.53 S	

Proportion as 1 is to 1.733.

*Struts.*

Number, .. .. 5		Number, .. .. 5	
Length, .. .. 1.16		Length, .. .. 1.00	
Total strain, .. S × 1.16		Total strain, .. S × 1.00	
Area, .. .. S × 1.16		Area, .. .. S × 1.00	
Contents, 5 × 1.16 × 1.16 S		Contents, 5 × 1.00 × 1.00 S	

Proportion as 1.35 is to 1.

Allowing for extra tracing in the Warren,  
say as 1.50 is to 1.

*Total.*

Ties, .. .. 8.10		Ties, .. .. 14.04	
Struts, .. .. 6.75		5	
		19.04	

Proportion as 1 is to 1.28.

**COMPARISON OF WEIGHT BETWEEN**

*Girder Fig. 3*

*and*

*Girder Fig. 6.*

*Proportions.*

Depth, .. .. 1		Depth, .. .. 1	
Length of bay, .. .. 0.58		Length of bay, .. .. 1.16	
"    diagonal, .. .. 1.16		"    diagonal, .. .. 1.53	
Weight on each bay,.. .. 6.5		Half " .. .. 0.765	
		Length of short struts, .. 0.50	
		Weight on each bay, .. 6.50	

*Top Flange.*

Sums of areas $\times$ length.	Sums of areas $\times$ length
904.80 $\times$ 0.58	467.48 $\times$ 1.16
	154.57 $\times$ 0.58
Contents, 524.784	Contents, 6.32
Proportion as 1 is to 1.15.	

*Struts.*

Sums of areas $\times$ length.	Sums of areas $\times$ length
146.25 $\times$ 1.16.	130 $\times$ 1
26 $\times$ 1	29.25 $\times$ 0.50
Contents, 195.65	Contents, 144.6

Proportion say as 4 is to 3.

*Ties and lower Flange.*

Sums of areas $\times$ length.	Sums of areas $\times$ length.
Diagonal, 117 $\times$ 1.16	Dragonals 289.25 $\times$ 0.765
Flange, 919.8 $\times$ 0.58	Flange } 301.60 $\times$ 1.16
Contents, 668.62	} 150.80 $\times$ 0.58
	Contents, 658.60

Proportion as 1 is to 1, nearly.

*Total.*

Top flange, .. .. . 524.78	Top flange, .. .. . 632
Struts, .. .. . 195.65	Shut, .. .. . 144.6
Ties, .. .. . 698.62	Ties, .. .. . 658.60
1,889.05	1,435.20

Proportion as 1 is to 1.03.

A cross girder at the centre of the bay would give the requisite lateral support to the flange; but, for reasons already stated, cannot be placed there without some support being also introduced underneath.

Hence the bay must be shortened, and to do so the double Warren, (*Fig. 3*), or the double Whipple Murphy (*Fig. 4*) must be resorted to. We may assume as a corollary to the proof already given, that a Warren (*Fig. 1*) is lighter than a Whipple Murphy, (*Fig. 2*), that the double trusses follow the same rule.

It may be suggested to shorten the bays as (*Fig. 5*), keeping the single triangulation by giving the diagonals less inclination; but such a truss is heavier than the double ones of the same system.

The truss, (*Fig. 6*), a modification of the Whipple Murphy, has been

introduced in America, and seems not unsuitable for light loads. A comparison is given of its weight with the double Warren, (*Fig. 3*), by which we see that it is very slightly heavier theoretically. An examination of this shows us that this truss more than others has the quality we are in search of, viz., a concentration of the strains into few members. The top flange is heavily loaded and we can give it a broad deep section throughout. The long struts are the shortest possible in a girder,—being vertical,—and fewest in number, but they are much more heavily laden than those of the double Warren. There is no difficulty, though, in giving them support at half their depth by vertical cross bracing between the girders which is easier introduced in this system than in the Warren. It seems probable too that, taking into account the inevitable waste in designing the ends and centre ties and struts of the Warren, the Whipple Murphy could be executed cheapest.

A perfectly rigid bridge can be constructed on this principle thoroughly braced between the girders both horizontally on the platform, and also on the level of the tie bar, and vertical bracing between the opposite struts of the girders, and at less cost; for every piece is doing its full work, and bracing between the girders must be much the same in all systems.

Having examined trusses for bridges with the road on the top, let us now proceed to do the same with the condition of the road between the girders.

All that has been said of parallel girders applies to this case also; but here we are not limited as before to the shape of the top flange. The girder (*Fig. 6*) is obviously unsuited to carry the load on the bottom, the short struts there not having any meaning except as supports to the top flange, which may be given by less expensive means.

When the girder is deep enough a system of horizontal bracing can be provided between the top flanges of the girders; but, at the same time, as no vertical bracing can be introduced between the girders, a greater width and stiffness should be given to the flanges and struts; and it follows that those trusses with a greater number of struts in the web are preferable where there is no suitable provision for the vertical stiffness of the girder in the direction of the width of the bridge. But to secure this stiffness without multiplying the members of the web is among the conditions laid down for us.

Bow-string girders have long been known as the lightest possible to

design, but for many reasons they have not found favor with engineers, who have found their advantage in weight counteracted by a higher price per ton; they require more accuracy in workmanship; and their appearance is not so pleasing as that of parallel girders.

Allowing all the objections against them, they still seem most suitable for the light loads we have to deal with in India, and best to fulfil our conditions. Parallel girders carrying a very light load are also, if designed only with a view of resisting the direct strains imposed, very light and would not have sufficient weight to counteract the vibration of a passing load, nor would their flanges and struts have sufficient width or stiffness; as has been explained, the web can now have no exterior support supplied to it.

It has been suggested that the way to avoid waste of material when dealing with these light loads is to find a truss which concentrates the strain into as few parts as possible. Now no truss can be found to do this in so perfect a degree as the bow-string, and hence its lightness. When at rest, the whole load is transmitted to the piers by the bow without any need of a web; when rolling load passes over the bridge, diagonals are needed to retain the shape of the bow. On account of the whole strain being in the bow, and as it increases from the centre towards the ends, we are enabled to give the bow the widest and deepest section possible without loss of material in any part of its length. The width of the bow gives width to the verticals and consequent stiffness; and as the length of the verticals decreases towards the ends their stiffness increases. The designer is not in any way limited in the length of his bay, but can make it the length best suited to his requirements; and the side surface exposed to wind is a minimum.

The platform and bracing thereon is the same as that for any other girder, and preserves the horizontal tie-bars in a truly straight line laterally. In low girders the stiffness of the verticals will preserve the perpendicularity of the bow over the tie-bar; and in long and deep girders bracing can be introduced over the centre bays, which is not wanted any more after the limit of height to which we can use it is passed, as then the girder itself is stiff enough; whereas parallel girders must be braced all along and especially the ends; while the ends of the bow-string are held fast by the platform and piers.

For these reasons it is contended that the bow-string girder, excels in

stiffness over all other girders, and therefore requires the least additional bracing. And on account of its stiffness and shape it is subject to less vibration. For all must admit that the amount of vibration is in some proportion to the proximity of the part to the origin of vibration. Thus the top flange must vibrate more than the bottom. Now the centre of the bow-string is the only part corresponding in depth with the parallel girder of the same span, and the depth of the bow-string rapidly diminishes. Also in girders too shallow to be braced on the top there must be more longitudinal horizontal vibration in the parallel flange with its free ends than in the bow-string with its two fixed points and those the ends.

As to surface exposed to wind it may be said to be so small in all cases as to be disregarded. So it is nearly: but it is an object to subject the girder to as little strain from exterior causes as possible. In cyclones which occasionally visit India, and in such a one as blew in Madras in May 1872, when ships were blown high up on shore, the strain must be considerable.

The strains on the web of a bow-string girder are very small and there is always an unavoidable excess of material in it. The verticals are braced as struts and do important work in stiffening the girder, and because of the diminution in height of the girder from the centre to the ends, and of the extreme lightness of the diagonals the excess of material is reduced to a minimum.

For many reasons the bow-string girder bridge seems the one best suited to carry the light rolling load of metre-gauge Railways. If it is possible to make a mistake in putting the girder together by transposition of pieces, it must be made on purpose; and the only riveting in the girder, if the web is connected by pins is in joining together pieces of the bow.

Because of the scarcity of skilled labor in India, connection by pins is the preferable method, and there can be no reason why with care in their manufacture they should not constitute as sound a fastening as rivets; and indeed, according to the theory lately advanced that a riveted joint depends for strength on the grip of the rivet heads, and the friction of the plates; pins would appear a fastening more to be depended on. If they are used their position in the flange should be carefully considered; frequently they are put too near the lower edge, the part least able to bear compression from its reduced section. The proper place for them is on the line of the neutral axis of the various sections there may be in



the length of the flange; then uniformity of strain throughout the section of the flange is secured.

The subject of this paper was suggested to the author when designing and estimating for the iron work of several large bridges on the Carnatic Railway in Madras; and he was then led to examine different trusses with a view of fulfilling the conditions imposed by the light loads of the metre-gauge. While doing so and looking over engravings of recent practice in railway bridges, he was struck with the divergence of practice of engineers under apparently the same conditions. There seems to exist a capriciousness in choosing the system of trussing; and yet it is certain that two trusses cannot equally best fulfil the same conditions. For instance, if the Warren girder used on the Great Indian Peninsula Railway for the Kistna and other large bridges is most suited to the 5 feet 6 inch gauge, why is a double system of triangulation adopted on the Scinde, Punjab and Delhi Railway under the same loads? However much money may be at the engineer's command it must always be his pride to display the power his science gives him of doing the maximum amount of work with the minimum amount of power or in this case material; and the really practical man is ever in search of these extremes.

At the same time the author noticed the apparently grave errors of construction condemned in this paper, and which are more glaring in American bridges than in those built by English engineers. The life of the girder must be shortened by a disregard of exposing it to extra and excessive strains; and economy of construction must be measured not only by cheapness of first cost but also by duration of the work.

As the writer has spent some years in India on the metre-gauge railways, the paper naturally alludes more to them and their peculiarities. He has put forward some system of trusses for both small and large spans, within certain limits, which appear to him to best fulfil the condition laid down at the beginning of the paper, viz., economical, that is light, and stiff, bridges for a very light rolling load. Concentration of strain is advocated for these loads by the adoption of the simplest or as they may be called the primary system of trussing. It is not desired to lay down any rule that this or that truss is to be used for such and such a span, but to guide the diligent engineer to examine before designing a bridge which system best suits his case.

As the dead weight of the bridge and the rolling load increase, so do many of the conditions put prominently forward in this paper disappear. For instance, for heavy loads it is more convenient to divide the strain among many members of the web, and the girder will be heavier and stiffer than is economically possible with light loads.

It is from the very lightness of the rolling load that the difficulty of designing Indian railway bridges arises; and if a road bridge can be combined in the same structure, a more economical bridge will result. The railways nearly always follow the main roads of the country, and there is no reason, considering the very few trains run, why the road should not be accommodated on the same platform as the railway. The platform would be of a heavier character, being entirely closed in and perhaps metalled, and the dead weight thus thrown on the bridge would to a great extent bring a uniform strain per sectional area throughout all the parts of the girder; and the bridge might be built, with the exception of the extra platform required by the road, for but little more than if only the railway was carried over it.

C. H. G. J.

## No. CXVII.

## MEMOIR OF KURRACHEE HARBOR WORKS.

[ *Vide* Plate XLII. ]

*Drawn up or compiled by W. H. PRICE, M. Inst. C.E., Superintendent of the Harbor Improvement Works.*

[*Note.*—The following Memoir, prepared by desire of the Commissioner in Sind has (with the exceptions to be noted) been drawn up from Official documents relating to the Kurrachee Harbor Works, or from personal knowledge.

Pages 192 to 204 are mainly a transcript of a Memoir drawn up in 1869\* by Mr. W. Parkes, M. Inst. C.E., Consulting Engineer to the Kurrachee Harbor Improvement Works, in which however, besides a change to the third person, some abridgement has been made, and some amplification from later and fuller knowledge.

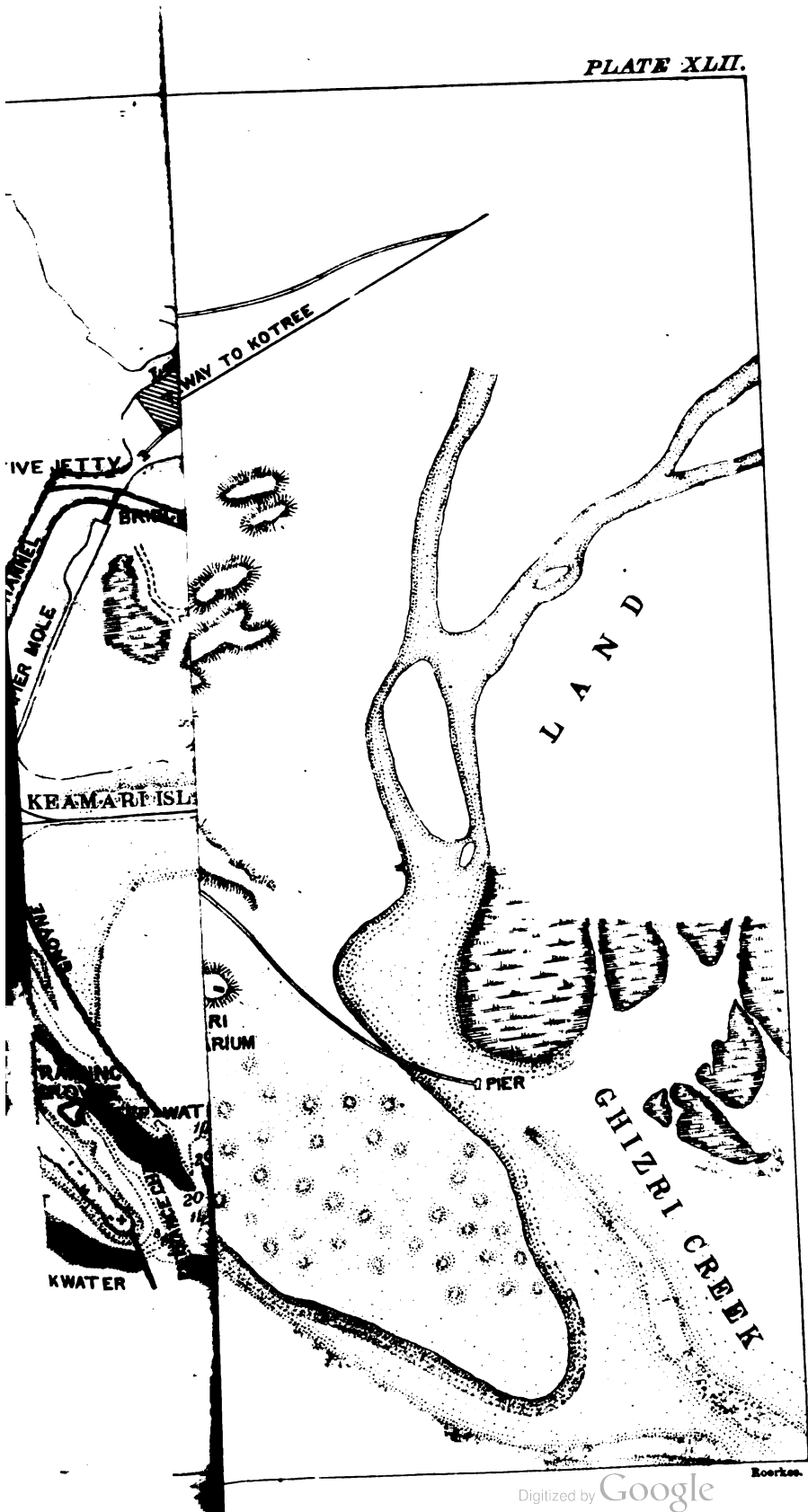
Some statistics of trade and other particulars connected with the history of the Port have been obtained from the "Sind Gazetteer," also some information in these particulars has been kindly afforded by the Collector of Customs and Master Attendant.]

*Description of the Harbor.*—The Harbor of Kurrachee (*Plate XLII.*) is situated on the northern border of the Arabian Sea, the entrance light being in latitude  $24^{\circ} 47'$  north, and longitude  $66^{\circ} 58'$  east, six miles west of the north-west (coast) angle of the delta of the Indus, and fifty-one miles west of the principal mouth of that river.

Cape Monze, the southern extremity of the Pabb (or Lukkeş) mountains, lies twenty miles to westward of the harbor.

This port bears much the same relation to the provinces of Sind and the Punjab, and to the mouths of the Indus, that Alexandria does to Egypt and the Nile. Both ports, notwithstanding their vicinity to the

\* See No. CCXLIII., Professional Papers on Indian Engineering, [First Series].





months of silt-laden rivers, maintain a vitality which seems mainly ascribable to the drift being kept off by the action of the prevalent winds, which in both cases blow from the port towards the river.

Thus the coast off Kurrachee dips to seaward very much more steeply than that off the eastern angle of the Indus delta, and—it may be added—is even more steep than that off Bombay. *See Appendix A.\**

The entrance of the harbor is flanked on the west side by the break-water lately constructed, running 500 yards in a south-by-east direction (into five fathoms depth at low water) from the base of Manora Point, a headland 90 feet in height, consisting of stiff clay capped by conglomerate rock, and dipping towards the north-west until at a distance of half a mile it meets a reef  $9\frac{1}{2}$  miles in length, extending to the mainland, and on which the surf has formed a beach topped by a ridge of blown sand.

On the extremity of the point, on a bastion of the (old Sindee) fort, stands the light-house, the apparatus of which is catoptric and of an inferior description.†

Eastward from Manora Point to Clifton hill opens a bay of  $3\frac{1}{2}$  miles in width, on the chord of which, at a distance of  $1\frac{1}{2}$  mile from Manora, lie the islets called the “Oyster Rocks” which, as well as Clifton, are of stratification similar to that of the Manora head-land.‡

From the Clifton shore westward for a length of  $2\frac{1}{2}$  miles, as far as the harbor anchorage, the head of the bay is separated from the east back-water by the sandy ridge of Keamari (300 to 500 yards wide), along which runs the Sind Railway, and which is termed an island, owing to its former separation from the Clifton land by the mouth of the Chinna Creek, the closure of which—recently completed—forms part of the harbor improvement works.

From Manora Point the Spit, called “the Bar,”§ runs in an easterly

\* There have been differences of opinion as regards the monsoon coast current, which will be found discussed at length in the printed volumes of Kurrachee Harbor Works correspondence.

There can however be no question as to the steepness of the coast off Kurrachee; and the vitality of the Harbor—which has never been directly questioned—is testified to by the records of accurate surveys extending over a period of 20 years.

† A design has been submitted for a new (dioptric) light, which has not however as yet been sanctioned.

‡ A native tradition, which is discussed at length in the Kurrachee Harbor Works correspondence, holds that up to about the middle of the last century a ridge or reef connected Manora with Clifton, and that the entrance to the Harbor was by a long narrow channel about 8 miles west of Manora, which was then closed, and the present entrance opened by an earthquake.

§ Chiefly sand, but having small patches of sand-stone rock, also boulders, shingle and clay, at its root near Manora.

direction, and the former exposed main entrance channel, only 14 feet in depth at low water, rounded the extremity of this Spit 1,000 yards from Manora.\*

Now however the Bar is cut across near its root, close to Manora, by the new and sheltered entrance channel, which is 20 feet in depth at low water, 900 yards in length, and is now being completed to its full proposed width of 500 feet.

This channel leads from the sea to the harbor anchorage, which commences opposite the south end of the stone groyne (one of the improvement works†) constructed along the ridge of the sand pit bounding the harbor to eastward for a distance of  $1\frac{1}{2}$  miles, up to the west end of Keamari island, where the lower harbor meets the "backwater."

On the west side northward from Manora the lower harbor is divided from the west backwater by a sand-bank extending to the mouth of the "Tullah" creek, which opens below "Baba," a small sandy island opposite Keamari.

The width between Manora and the south end of the groyne is 710 yards, and the width opposite Keamari 930 yards, the entire area of the lower harbor at low water being 700 acres, of which however only 121 acres having a depth of from 20 to 60 feet at low water is suitable for large vessels.‡

From Keamari the shallow backwater spreads out West, North, and East for a total area [at high water spring-tides] of 18 square miles, through which branch numerous creeks and the new boat-channel which leads to the town wharves or "Native Jetty," and taps the East backwater. This channel and the "Native Jetty," form part of the harbor improvement works.

From Keamari to the mainland the backwater is traversed by the causeway, called the Napier Mole, nearly 2 miles in length, forming the road communication with Kurrachee, and near the upper end of which is an opening 1,200 feet wide which now passes the waters of the East backwater, and is spanned by an iron screw-pile bridge, one of the improvement works.

\* There was also a west entrance channel, at about the same place where the new channel has since been formed, having a depth of 11 feet at low water.

† The portion of this first constructed 2,516 yards in length, is called the "Keamari Groyne," and its extension, 500 yards in length, the "East Pier," the two however may be looked on as one work under the name of the "Groyne."

‡ Before the improvement effected by the Keamari groyne, the deep water-space was only 99 acres, and (the Keamari portion especially) far less suitable for anchorage, owing to eddies.

The backwater is covered throughout to entire area by high water of spring tides,\* and with the exception of the creeks, of the portion West of "Nowa Nāl," and (for the present) a pool in the East backwater, the whole drains off at low water springs, thus constituting an immense natural sluicing reservoir, by which the deep water-space of the lower harbor and the entrance are maintained.

The only river channel discharging into the harbor is that of the Layari, which debouches at the head of the backwater near the town of Kurrachee, flowing at most only for a few days each year when heavy rain falls in the hills.

Though for the short time it flows, this stream is of considerable volume and carries down a large quantity of sand, nevertheless it is not found to have any appreciable permanent effect, either favorable or otherwise, on the harbor.

The backwater, shallow as it is, and receiving during the south-west monsoon a copious sand-drift from the West beach and Keamari, and the detritus washed in by the (occasionally heavy, though infrequent) rainfall round its borders, shows a remarkable vitality, which seems due mainly to the action of the strong monsoon winds, raising a ripple and so stirring up material which goes out with the ebbing tide. The flood-tide on the contrary, making from the Westward, runs in blue and clear, even during the monsoon, round Manora Point.

*History of the Port.*—Previous to, and for some years after, the conquest of Sind, the harbor of Kurrachee was generally considered to be barred against the entrance of European vessels, though an exception is on record in the entry and departure of the two vessels (of a small class however) belonging to the Honorable East India Company's Marine, by which—in 1809—the mission headed by Mr. Ellis was conveyed to Sind.

In the early years of intercourse with the Province, steamers and ships were accustomed to anchor outside Manora Point, and there to transfer the troops and stores into boats, by which they were conveyed up the harbor as far as the tide permitted, and thence again transferred in smaller boats to a spot near the site of the present Custom House, at the head of the harbor.

After a time it was found that the difficulties presented by the bar were not so great as had been supposed, and that vessels of moderate draft

\* The rise of an ordinary spring tide is 9½ feet.



could cross it with safety. This induced parties in England to send ships direct to Kurrachee, and the first of these was the "Duke of Argyll," a vessel of 800 tons, which arrived in October 1852, carrying troops and a cargo of coals and iron. After this the port became better known, and the number of ships rapidly and steadily increased, though the bar still continued to be a serious drawback.

The growth of the trade of the port may be judged of from a comparison of the value of the exports and imports, which in 1843-44 was £116,052, and in 1872-73 (a bad year) £3,370,076. The increase has not been without fluctuations, the chief rise having been caused by the American war, while of late years the opening of railways from the eastward has drawn off much of the Punjab traffic, in the absence of through railway communication by the Indus Valley route, a drawback which it may be hoped will before long be removed by the State railway works now in progress. During the current year, owing to the opening of the Suez Canal, the accessibility of the port to large steamers, and the removal of Customs duty, the export trade in wheat has grown to much importance.

A detailed statement of the value of the trade and of realizations by Customs' dues over a period of years will be found in Appendix B.

The number of vessels wrecked at or near the harbor of Kurrachee from 1856 to the present time is eight, of which six were sailing vessels and two river steamers.

A detailed statement of these wrecks is given in Appendix C.

By this it will be seen that out of the entire number of sailing ships, five were wrecked owing to difficulties more or less directly caused by the want of a direct, deep, and sheltered entrance channel, which has since been provided.

The sixth ship was wrecked on the Indus banks, near the Pitty mouth, about 12 miles from Kurrachee, and this would probably not have occurred had the Manora Light been of a more powerful class.

The wrecks of the two river steamers did not arise in any way from difficulties of the harbor, they broke up when leaving the port, owing to defect of construction.

It may be judged from the small number and the particulars of these wrecks, that Kurrachee harbor is safe and easy of approach, in fact there is probably no Indian port more (if so much) so, as the soundings are regular, there are no outlying dangers, or formidable currents, and in the

only season of hazy and rough weather, *i. e.*, the three months of the (so called) south-west monsoon, the prevailing wind being steady from the westward, a sailing vessel can work off from shore without difficulty.

Kurrachee has also the great advantage of being to northward of the limit of cyclones, in fact violent gales are unknown there, the south-west monsoon being at its worst only a high wind, though it brings a heavy sea.

The scantiness of the local rainfall also is in favor of this port, where trade can be carried on during the south-west monsoon, free from the interruption or inconvenience felt at that season in the ports of Western India.

The first works of accommodation executed in connection with the harbor of Kurrachee were the timber-pile Pier at Keamari, (accessible to native craft and lighters,) and the Napier Mole causeway, 2 miles in length, connecting Keamari island with the town of Kurrachee, and the upper part of which afforded a shallow wharfage to native craft. These works were initiated by Sir Charles Napier during his government of Sind, but were not completed until 1853 during the Commissionership of Mr. (now the Right Honorable Sir) Bartle Frere.

Both works were of considerable utility in facilitating traffic between the shipping and Kurrachee, but the Mole affected the harbor unfavorably by cutting off about one-fourth of the backwater space,\* and by causing accumulation in the creek leading to the head of the harbor.

It appears that Sir Charles Napier from the first contemplated openings in the Mole, these however—under the advice of his Senior Naval Officer—were not carried out during the construction of the work, but the want has since been remedied by the opening and iron bridge already referred to as part of the improvement works.

*Harbor improvement Works.*—The increasing trade and importance of the port now caused attention to be strongly directed towards the improvement of the harbor, and especially of the entrance, the deepening of which had indeed from the first engaged the attention of Sir Charles Napier, though no plans were then framed for carrying out the work.

Accordingly, from about 1852, under Mr. Frere's direction, the question was subjected to much discussion and enquiry by the Government

\* The space thus cut off still communicated with the sea by the Chinna creek, the mouth of which became greatly enlarged by the increased scour, and has recently been closed as part of the improvement works.

Engineers, headed by Major (now Major-General) Turner, the Superintending Engineer, in Sind, on whose advice an accurate survey of the harbor was made by the late Commander Grieve, Indian Navy.

Mr. Hardy Wells, a Civil Engineer of the Sind Canal Department, and afterwards the first Chief Engineer of the Sind Railway, took a prominent part in the discussion, and wrote a pamphlet on the harbor improvement question, in which was first publicly broached the project of removing the bar by natural scour.

This local discussion and enquiry went on for about four years, after which, on the suggestion of Major Turner, the question was brought before the Home Government, with the view to its being submitted to some Civil Engineer of eminence, and of special study and experience of harbor works.

The result was that the late Mr. James Walker was consulted as to the improvement of the harbor of Kurrachee in 1856, and on the 8th September of that year he made a preliminary report, based on the charts and documents furnished to him from India, and on information given by Mr. Frere, and by other gentlemen connected with the locality, who were at the time in England.

Mr. Walker's conclusion was that through the application of proper means, the "deepening or even entire removal of the bar, and the general improvement of the harbor," might certainly be accomplished.

Rather by way of illustration, than as pledging himself to any particular plan, he suggested a system of works which he thought would be suitable for the purpose. He at the same time recommended that an Engineer should be sent out to make the necessary surveys and examinations on the spot, and report to him previous to his making a complete design.

Mr. Parkes was appointed to this service, on Mr. Walker's recommendation, by the Court of Directors of the East India Company in the latter part of 1857, and after spending five months at Kurrachee, he returned to England and reported to Mr. Walker in June 1858.

Mr. Walker's second report, with which Mr. Parkes' report to him was combined, was made in October of that year. In it he confirmed the general principles which he had laid down in his former report, and repeated his recommendation as to the works to be executed, with little variation from his original suggestions.

Those works, which are shown on the accompanying plan, were, shortly, as under:

1. A breakwater in a direction south-by-east for 1,500 feet from Manora Point (Estimate £110,000).
2. A stone bank or groyne from the western end of Keamari island to opposite Manora Point, so as to confine the whole of the ebbing and flowing waters to the main channel of the harbor for a length of about two miles, and the entrance to a width of about 2,000 feet (Estimate £42,000, and east pier extension, if required, £40,000).
3. The diversion of the tidal-water which ebbed and flowed through the Chinna creek, into the harbor itself, by closing the creeks (£9,000); removing a portion of the Napier Mole, and carrying a bridge on piles over the opening (£40,000); excavating a channel into which the tide-waters would be collected and conducted into the harbor (£18,000); and the formation of a jetty ("Native Jetty") for further guiding them, which would be also used for wharfrage (£28,000, or for the whole of this series of works, £95,000).

Thus the estimate for the improvement of the harbour (exclusive of docks and basins, for which Mr. Walker indicated the best sites and arrangements) was, in round numbers, £300,000.

As the result of these works, Mr. Walker anticipated that a depth of at least 20 feet at low water of spring tides, giving 29 feet at high water of spring tides, and 25 feet at that of neap tides, with ample width for navigation sheltered from the worst winds, might be depended on.

The groyne, besides bringing the whole scouring power of the harbor to bear upon the entrance, was also calculated to enlarge and improve the anchorage; and the diversion of the Chinna creek waters, besides further increasing the scour on the entrance, would form and maintain a channel of sufficient capacity for the passage of the largest native craft up to the proposed new jetty near the town, and the offices and warehouses of the merchants.

It is worthy of remark that although Mr. Walker's proposals have been met by strong opposition from many quarters, and every detail has been subjected to the severest criticism, only one specific proposal of any other

system of improvement (that of Lieutenant Taylor, I. N., in 1860) has since been made, and that has not been pressed.

Thus the only recommendation ever prominently brought before the Government or the public has been to carry out Mr. Walker's plans in their integrity. All the opposition has been of a negative character, including that so strenuously led by General Tremeneere.

Mr. Walker's plans, submitted, as above stated, in October 1858, having been considered by the Government, it was decided on financial grounds that it was undesirable to give immediate sanction to the expenditure of so large a sum as £300,000, and it was therefore determined, with the very qualified and reluctant concurrence of Mr. Walker, to defer the sanction of the execution of the Manora breakwater. He afterwards (in April 1861) took an opportunity of formally expressing his regret at this decision.

In February 1859, then, the Keamari Groyne and the system of works connected with the diversion of the Chinna Creek waters, at an aggregate estimated cost of £137,000, were sanctioned by the Secretary of State for India in Council, who decided to place the execution in charge of the Officers of the Public Works Department, under the general superintendence of Colonel (now Major-General) Turner, R.E., then Chief Engineer in Sind, and who, having been in England and having frequently conferred with Mr. Walker during the preparation of the design, concurred in his recommendations. Mr. Walker had further recommended that tenders for the execution of the whole of the sanctioned works should be asked for from responsible Contractors.

Colonel Turner, however, having represented the improbability of any large Contractors in England tendering for the execution of any of the recently sanctioned works, with the exception of the iron work for the Napier Mole bridge, the Secretary of State decided to abandon the idea of inviting Contracts in England, leaving it to the Government of Bombay to have the works (with the above-mentioned exception) carried on either departmentally, or by means of arrangements entered into with Contractors in India.

A despatch was accordingly sent to Bombay, authorising the Government to adopt whichever mode might on enquiry appear most advisable, and adding that detailed drawings and specifications of the works would speedily follow, which must be strictly adhered to, no deviation being allowable without Mr. Walker's previous concurrence.

The detailed plans and specifications were accordingly furnished by Mr. Walker in April 1859. These documents were prepared without the cooperation of Mr. Parkes, who believed them to have been furnished on the understanding that they were to be adopted, modified, or rejected entirely on the responsibility of the Local Engineer.

Mr. Walker's advice and aid were further resorted to in the matter of the provision and inspection of the plant sent out from England, and the engagement of foremen, and he replied in 1860 to a reference made to him from Kurrachee through Colonel Turner, regarding the depth of the jetty and bridge foundations, also in 1861 he reported to the Secretary of State on Lieutenant Taylor's scheme.

The last-mentioned was the final service performed by Mr. Walker or his firm in connection with Kurrachee Harbor. He died in 1862.

Orders were given for the commencement of the works early in 1860, Mr. Price, C.E., (an Executive Engineer of the Sind Canal Department,) having been appointed Superintendent, under the general direction and control of Colonel Turner, Chief Engineer in Sind. Mr. Price has since continued in charge of the works, excepting two years' sick leave, 1864-65 (busy years), during which Lieutenant (now Major) Merewether, R.E., acted as Superintendent.

In May 1861 Colonel Turner was succeeded by Colonel Tremenheere, so that the works had not made sufficient progress to show material results before his connection with them ceased. Colonel Tremenheere from the first took an unfavorable view of Mr. Walker's plans, both in their principles and details, and persistently urged their abandonment upon the Government.

The offers obtained from Contractors in India having amounted to from double to treble Mr. Walker's estimates, the works were from the first carried on departmentally, petty contracts being resorted to so far as practicable for labor and materials.

In the early part of 1862 a revised estimate was made of the probable cost of the works as they were being executed, the amount of which was very much in excess of that of Mr. Walker's.

Much of this discrepancy is attributed by Mr. Parkes (while admitting that the details of the works were executed with every regard to economy) to misapplication and misunderstanding of the plans and specifications furnished by Mr. Walker, arising from a want of communication between that gentleman and the Engineers in charge while the works were in progress.

On the other hand the Engineers in charge represent that, with the exception of duly authorised departures, the plans and specifications were strictly followed in accordance with the original orders, and attribute the excess of cost partly to the original estimates having been framed at English rates, partly to the increased cost of labor and materials caused especially by the demand for the Sind Railway works,\* and partly to the increase (under Mr. Walker's advice) to the depth of the foundations of the jetty and bridge. The excess occurred mainly in the Napier Mole bridge, native jetty and new channel works, which estimated originally at £86,000, cost nearly double that amount, the chief excess being on the last-mentioned work, a modification of which with the view to great reduction of cost was proposed by Mr. Price in 1862, but was not sanctioned by Government, who agreed with the Chief Engineer in Sind in considering that Mr. Walker's specification should be adhered to. The Keamari Groyne (and East Pier, so far as executed) cost less than the original estimate, owing to saving in quantity, and omission of dressed stone, a change sanctioned by Government on the understanding that the omission could be afterwards supplied if found requisite.

The Keamari Groyne was commenced in November 1861, and was completed in April 1863 to the length proposed by Mr. Walker, viz., about a mile and a half. Mr. Parkes considers that there were no special physical reasons for the termination of the groyne at this particular length, and that it was no doubt assumed that before that length should have been completed, new materials for deciding the questions of its extension and of the principles of its construction at the outer end would have been collected, and that if an extension should appear desirable, it would be proceeded with without interruption. Mr. Price did in fact recommend such an extension early in 1863, and his recommendation was supported by Genl. Scott, Chief Engineer of the Bombay Presidency, but being opposed by Colonel Tremenheere, it was not prominently brought before the Government.

About the same time, that is in 1863, the works necessary for the diversion of the Chinna Creek waters were so far advanced, that preparations were made for closing the creek and removing the dam which separated the Chinna Creek marsh from that of the harbor.

Such was the state of the undertaking when, in October 1863, Mr.

\* The Sind Railway works were in active progress under the departmental system, the Contract with an English firm having been broken off.

Parkes was instructed by the Secretary of State, at the request of the Bombay Government, to give his opinion whether any of the facts noticed by Colonel Tremenheere in certain reports made by him to Government "rendered a change in any part of the plans of the harbor works advisable."

The facts so brought to notice were the effects produced by the action of the groyne upon the scour of the harbor, as shown by surveys made in January and April, 1863. Those effects may be described, shortly, as follows:—

A very large quantity of sand ( $23\frac{1}{2}$  millions of cubic feet) had been washed out from the harbor channel, thereby increasing the water-space of that portion of the harbor about 9 per cent. But of the sand so washed out a portion, though a very small one, had been deposited in the line of navigation between the end of the groyne and the sea. Moreover, the action of the scour extending to the bar at the entrance, which consisted of a very fine light sand, had completely deranged the form of equilibrium which the contending actions of the scour of the tidal waters in their original volume, and the surf raised by the south-west monsoons, had impressed upon the materials of the bar. Portions which were formerly deep had been filled up, while other parts had been lowered. The effect on the whole was encouraging as to the ultimately beneficial action of the increased scour, which had already carried so large a quantity of sand clear away to sea, but the immediate effect was injurious to the navigation of the entrance.

In view of these facts, Mr. Parkes expressed a confident opinion that the actually injurious action was only temporary, and that the evil would cure itself, but that as to any recommendations for further works which might be advisable for reducing the temporary evil to a minimum, or obtaining the maximum of ultimate advantage, he wished before making them to see what had been the effect of the monsoon then just over. His definite recommendations, therefore, were confined to one point, viz., that the diversion of the Chinna Creek waters then about to be carried out should be postponed. He advised this in the belief that the temporary evil then affecting the entrance was due to an excess of scour too hastily thrown into the channel, and that a further addition of scour, in the then condition of the entrance, would aggravate the evil. At a future time, when the channel should have recovered itself, and with certain precautions, he considered that the diversion might be carried out with much advantage.



Shortly after the delivery of this report, Mr. Parkes was instructed to visit Kurrachee, and after making a full investigation into the whole subject, to report to the Bombay Government.

With this view he arrived at Kurrachee early in January 1864, and remained there for two months. He had then the advantage of meeting Colonel Tremenheere, and of discussing the whole question with him, and they informed each other unreservedly of their respective conclusions, except upon one point which Colonel Tremenheere afterwards brought prominently forward, and which gave rise to much correspondence.

The effects produced during the monsoon were principally the following :

- 1st. The characteristic form of the bar was restored, a high bank of sand being piled up as a barrier immediately in front of the entrance, while the circuitous channel round the tail of this bank was re-opened to the same depth as formerly, but to a less width (and consequently less depth available for navigation).
- 2nd. A considerable quantity of sand was washed into the harbor channel, partially replacing that which had been washed out previous to the monsoon.

In view of these facts, Mr. Parkes repeated his previously expressed conviction that where actual injury to the navigation had been produced, it was only of a temporary character, and would disappear as the principles of the design were carried out.

The accumulation of sand in the harbor channel he believed to be due in great measure to exceptional causes, though he was not prepared to explain the whole action.

He thought, however, that certain obvious evils were caused by the position of the end of the groyne, and recommended its immediate extension for 1,500 feet, also that some assistance should be given to the natural scour for the removal of the opposite shore of Deep Water Point, so as to bring the force of the current nearer to the Manora shore.

With respect to the monsoon action on the bar, Mr. Parkes cited it as a confirmation of the opinion originally expressed by Mr. Walker and himself, that the south-west seas were an active agent in its formation and maintenance, and that it must be sheltered from them before any material measure of improvement of the entrance could be looked for. He therefore recommended the immediate construction of the Manora breakwater as laid down by Mr. Walker, but without pledging himself to its sufficiency.

On receipt of this report, the Bombay Government immediately sanctioned the extension of the groyne and the removal of hard material from Deep Water Point, which works were at once put in hand, and the first mentioned completed by May 1865, the hard material was also cleared from the surface of Deep Water Point, but the entire removal of that obstruction was found to involve protection of the shore and removal of buildings, as well as excavation of rock, which up to the present time has not been completed.

The construction of the Breakwater (of which the estimated cost was about £120,000) was recommended to the Secretary of State for his sanction.

In the meantime Colonel Tramenheere, with Mr. Parkes' report before him, prepared an elaborate statement of his views, which he embodied in a report to the Commissioner in Sind, dated 19th May, 1864.

In it he gives the following summary of his opinions:—

- 1st. The peculiar position of the harbor, with reference to the monsoon surf acting on the shallow coast, has not hitherto met with sufficient consideration.
- 2nd. The increased velocity given to the tides by the construction of the groyne, has increased the size and height of the bar, instead of opening a passage through it, or scouring it into deeper water, as was intended.
- 3rd. The tidal water to fill the harbor being now drawn from the vicinity of the breakers on the bar, and carried at a high velocity through a narrow deep funnel, is much more laden with sand, silt, and mud than it was formerly, and the amount of such sedimentary matter brought in by the flood during the monsoon, much exceeds what can be lifted and carried out by the ebb-tides, so that the amount of deposit within the harbor must annually increase.
- 4th. The result of extending the groyne still further must be to draw water during the flood-tide still more heavily charged with sand, and to cause still more rapid injury to the harbor.
- 5th. The bar has increased both in length and width and height since the works were commenced, and the depth of water in the entrance channels has been materially reduced.
- 6th. We find both within and outside the harbor the preservation of the general form, combined with a change of material from

very light to heavy sand,—a result which it should be an Engineer's object to avoid.

7th. The proposed Breakwater would not afford any effectual shelter to that part of the bar, which Mr. Parkes wishes to scour away, and it is very improbable that a deep channel could be formed in that direction.

It may be at once stated that the 2nd, 3rd, 4th, 5th, 6th, and 7th of these conclusions have—with one partial exception—been disproved by experience, based as they were upon the observation of effects which have long since disappeared.

The partial exception is the lengthening of the bar to eastward by deposit of a very small proportion—about two per cent.—of the material washed out from the harbor. This accumulation however does not at all affect the part of the bar which it was from the first contemplated to improve, and in which the object sought—of a deep and sheltered channel—has since been successfully attained.

The first objection is supported by a theory for the first time promulgated in this report, and as to which Colonel Tremenheere was silent in his previous communications with Mr. Parkes, viz., that there is during the south-west monsoon (when direct observations are impracticable) a coast current, produced by the action of the waves, running from the mouth of the Indus towards Kurrachee. The theory is supported by the fact (disputed by some persons, though it is believed, admitted by the majority) of the existence of minerals, especially mica, peculiar to the valley of the Indus, in the mud of Kurrachee harbor, and still more directly by the results of an experiment made by Colonel Tremenheere during the monsoon of 1865, in which out of a number of bottles set afloat at the mouth of the Indus, a considerable proportion\* were found on the beach a few miles to the eastward of Kurrachee harbor.

Colonel Tremenheere attributes the existence of the current to the supposed oblique action of the surf on the sandy coast, but in this part of his argument he is believed to stand absolutely alone in the support of some of the more important of his alleged facts and his inferences.

This coast current theory has been made the subject of a great deal of discussion, and has been contested from many points of view, but so far

\* About one-fourth, of which all except two had been thrown in on the ebb, though 214 had been set afloat on the flood tide.

as it regards the design for the harbor improvements, the discussion may be concentrated in two simple questions.

- 1st. If such a current exists, where is the evidence of its deteriorating effects upon a harbor of such acknowledged vitality as Kurrachee ?
- 2nd. Even if it be calculated to injure the harbor, what can better mitigate the evil than the Keamari groyne, which provides in the angle between it and Keamari island a trap for all silt brought from the eastwards, from whatever source, and prevents its entering the harbor ?

After the lapse of nine years, no facts or arguments have been brought forward which suggest replies to either of these questions.

Colonel Tremenheere concludes by a recommendation that the whole question should be referred for the opinion of scientific men.

This report, as above stated, was dated May 1864. In September 1865, sixteen months later, the Government of India recommended that the questions at issue between Colonel Tremenheere and Mr. Parkes should be referred to some independent Engineer for his opinion, and in accordance with this recommendation, Messrs. D. and T. Stevenson, of Edinburgh, were instructed by the Secretary of State to report on the following questions :—

- 1st. The validity or otherwise of Colonel Tremenheere's objections, and the consequent expediency or otherwise of stopping the works.
- 2nd. The amount of probability on general considerations, that Mr. Walker's plans, if prosecuted to completion, will effect an improvement of the harbor commensurate with their cost.

Messrs. Stevensons' report was presented on the 26th February, 1866. Although the form of their conclusion is favorable to Colonel Tremenheere's objections, yet their line of argument shows no one point of contact with Colonel Tremenheere's. Of the various questions at issue between him and Mr. Parkes, many are not mentioned ; and a decision is not given upon any one. They state that they hold one opinion even more strongly than Colonel Tremenheere and Mr. Parkes, though there is nothing in Colonel Tremenheere's report to show that he holds it at all, viz., the necessity of protection from the sea ; and upon the alleged ground that Mr. Walker's breakwater is insufficient for this purpose, they conclude that " Colonel Tremenheere's fears as to the success of Mr. Walker's

plans are well founded." It will be observed that the sufficiency of Mr. Walker's breakwater was an open question with Mr. Parkes in 1864, and Messrs. Stevenson lay down no principle for the determination of what the extent should be. They do, indeed, say that the whole of the extensive sand bank, called the bar, must be thrown completely under shelter, but this is a condition which may be interpreted with great latitude, and in a very reasonable sense might (as the result has proved) have been met even by Mr. Walker's short breakwater.

On the whole, it may be said that Messrs. Stevensons' report served to obstruct the progress of the works as designed by Mr. Walker, but did not give the slightest clue to the principles on which an improved design might be based.

Messrs. Stevensons' report was made the ground of an order by the Secretary of State, issued in April 1866, to "stop the works." There were no works at that time in progress, excepting Deep Water point removal, all others already sanctioned having been completed, but the order of course involved the refusal to the sanction of any new works.

The Government of India acquiesced in this decision, considering that, though the improvement of Kurrachee Harbor was an object of great importance, it would be better to wait till some plan commanding general confidence should be proposed.

The Government of Bombay called for and received a report from a Committee, consisting of Captain Giles, I. N., Mr. Price, C. E., and Captain Merewether, R. E., which was favorable to the prosecution of the plans of Messrs. Walker and Parkes.

This report the Bombay Government forwarded to the Secretary of State and to the Government of India, at the same time pointing out the inconsistent character of Messrs. Stevensons' conclusions, and suggesting a further reference to them for explanations, to be followed, in the event of this second reference not resulting in a withdrawal of their unfavorable decision, by a still further reference to some Engineer whose authority would justify the summary condemnation of Mr. Walker's designs.

Lord Cranbourne, then Secretary of State, did not adopt this suggestion, and the matter remained in abeyance for some months. During the suspension however, the side favorable to the prosecution of the works was strengthened by the replies of Messrs. Parkes and Beardmore to Colonel Tremenebeers' and Messrs. Stevensons' objections, by the warm

support of the Acting Commissioner in Sind, and of the Kurrachee Chamber of Commerce, as well as of the Sind Railway Authorities; by the favorable remarks of Mr. Ormiston, C.E., and last—not least—by the disappearance of most of the symptoms so much dwelt on as unfavorable by Colonel Tremenheere.

In January 1867 the Secretary of State practically admitted an appeal from the previous decision by referring the question to Sir Seymour Fitzgerald, then just appointed to the Government of Bombay.

Owing to other engagements, and especially to the pressure of business connected with the Abyssinian Expedition, His Excellency was unable to visit Kurrachee till January 1868. In that month, however, he did so, accompanied by General Tremenheere, and after a full investigation of the whole matter and of General Tremenheere's objections, he transmitted to the Secretary of State a strong recommendation for the immediate resumption of the works as designed by Mr. Walker.

In the following June, under instructions from the Secretary of State, Mr. Parkes proceeded to India, and, after full re-consideration of the whole subject in conjunction with the local authorities and officers, he reported his conclusions as to the effects of the works already executed, and his recommendations as to future proceedings.

His conclusions may be summed up as follows :—

That the works already executed had had a very beneficial effect on the interior of the harbor, expelling from it about two and a quarter millions of cubic yards of sand, by which the water-space of the anchorage was increased 14 per cent., while, by rendering the courses of the tidal currents more regular, they had made it so much more secure that the number of ships capable of being moored was increased from 20 to 55, and those of a larger tonnage.

That the injurious effects produced upon the bar and entrance immediately after the completion of the groyne had disappeared, leaving the navigation practically what it was before the works were commenced.

That although no actual improvement of the entrance had been effected, certain conditions necessary for effecting improvements had been established, which would produce useful results when supplemented by other conditions not yet provided.

Upon these conclusions Mr. Parkes based the following recommendations :—

That the breakwater, nearly as originally laid down by Mr. Walker, should be constructed, and, with a view to directing the scour of the ebb-tide into the most advantageous line, the bar and some of the shoals in the lower part of the harbor should be dredged.

That the obstructions in the entrance originally caused by the too sudden addition of scour to the harbor having been now cleared away, there was no further necessity for delaying the admission into the harbor of the Chinna Creek waters, the scour of which would effect a great improvement in the channel up to the wharfs near the town.

That in order to insure unity of purpose in the further prosecution of the works, the general direction of them should be placed in his hands as Consulting Engineer, in direct communication with the Officers of the Public Works Department now in charge of the works.

These recommendations having been duly considered by the Secretary of State, and by the Governments of India and of Bombay, the completion of the works was sanctioned in November 1868 by the former authority, who also in March 1869 intimated his appointment of Mr. Parkes as Consulting Engineer for the Kurrachee Harbor Works for a period of five years from September 1868. The Secretary of State at the same time requested the Government of Bombay to furnish the Superintendent in charge with such instructions as might be deemed suitable for regulating his relations to, and communications with, the Consulting Engineer. On this the Bombay Government ruled that all orders regarding the work and its progress, and all appointments, would be made as heretofore by Government, to whom should be rendered all returns and official reports, of which such as they might think fit would be forwarded to Mr. Parkes.

At the same time Government left it open to the officer in charge of the works to be in as free un-official communication with Mr. Parkes, as might be agreeable to them both.

Active operations were accordingly resumed early in 1869, and the works have since been carried on without a serious check, excepting the temporary stoppage (caused to them in common with most other Indian Public works) under the "deficit" orders in 1869-70.

In order to describe the progress made since the resumption, a summary will now be given of the operations of each official year.\*

\* The official year commences 1st April and ends 31st March, but for convenience of correspondence with the working seasons, the quantities of work are given in accordance with the latter.

1868-69.—As the resumption took place within (though towards the close of) this official year, it may be briefly stated that the deposit of rubble stone to form the base of the Manora breakwater was commenced on the 17th March, 1869, and 9,165 tons put in before the monsoon, also that the dredging on the bar in line of the new (west) entrance channel, which had been cleared by scour to 11 feet in depth, was commenced\* on 21st December, and a depth of  $13\frac{1}{2}$  feet, at width of 240 feet, reached by the close of the season, during which 65,032 tons were dredged, including a considerable quantity of boulders and shingle.

On Deep Water Point some dredging (8,261 tons during the season) was done, including much shingle and some fragments of rock, also the stone facing was secured and prolonged, and some shingle removed by hand.

Preparations were also made towards the diversion of the Chinna Creek waters, by repairing the staging across the mouth of the creek and the line at either side, for the passage of the Sind Railway traffic, so as to enable the line to be removed from, and a cut be made through, the temporary embankment alongside the Napier Mole bridge.

Some delay, as well as loss, was suffered by the want of the plant transferred in 1867-68 to the Abyssinian Expedition.

Some smaller works and repairs carried on under this charge during this and following years need not be noticed, as not forming part of the main project of harbor improvement.

The elaborate periodical surveys were carried on as usual during this, as well as previous (from 1863) and subsequent years, chiefly by Mr. Humby.

1869-70.—The works were stopped (to serious inconvenience and loss) from December 1869 to February 1870, under the "deficit" orders, but nevertheless the rubble base of the breakwater was carried to half its proposed length of 1,500 feet, making one-fourth the contents of the base, 16,238 tons having been deposited during the season. A portion of the superstructure, extending 86 feet from shore, was nearly completed, the blocks having been moulded "in situ" so as to make a starting place for the building with the "Titan" on its arrival from England.

\* Under orders from the Secretary of State, on recommendation by Mr. Parkes, dredging had been carried on for two months in the previous season, 1867-68, at the middle of the bar, but in that exposed position the narrow channel gained, 14 feet in depth, shoaled up at once at the burst of the monsoon of 1868.

The quantity dredged was 18,906 tons.



The approach and block ground were also in forward preparation.

The experiments on concrete blocks, Portland cement, and artificial hydraulic lime resulted clearly in favor of concrete blocks for the superstructure, and of cement, in preference to lime.

The dredged entrance (west) channel of 1868-69 proved of great value during the monsoon, but shoaled about  $2\frac{1}{2}$  feet (chiefly at the outer end), increased to  $3\frac{1}{2}$  feet during the fair season up to resumption of dredging.

The "deficit" stoppage prevented much being done at this work, but after funds were provided, 22,073 tons were dredged, including some boulders and shingle, and leaving the channel in a state slightly better than that gained the previous season.

The Sind Railway traffic having been shifted to the Keamari route, the diversion of the Chinna Creek waters was commenced in August 1869, by making a "Notch" of 175 feet in width, in the temporary embankment at the north end of the Napier Mole bridge. The immediate effect of this was not great, the ebb discharge not exceeding one-ninth that of the creek, so that a further contraction of the latter was evidently required, and all the more so to save further expenditure in clearing the boat-channel to the native jetty, on which Rs. 7,492 was expended during the year.

The office, workshops, and store-buildings were removed to Manora, a landing pier and quarters for Establishments constructed, and other preparation made for pushing on the breakwater works, on the arrival of the plant from England.

1870-71.—Fair progress was made during this year, though the supply of funds was not fully sufficient for speed or economy.

Only 8,024 tons of rubble were deposited in the base during the season, the funds being more pressingly required for the superstructure work. The plant having arrived from England, the making of concrete block was commenced in August 1870, on the 1st November following the first (27 ton) block was set by the "*Titan*" crane in presence of Colonel Sir William Merewether, K.C.S.I. and C.B., Commissioner in Sind, and of a large assemblage,—all the proceedings passing off successfully.

The setting then steadily progressed, though retarded by the irregularities of the bottom near the shore, and by the want of a full party of divers, also by some interruptions from weather. By the close of the season, 4th March, 1871, the superstructure was out 270 feet from shore.

The dredged west channel continued to be of great use during the mon-

soon of 1870, but shoaled a foot at outer end, less however than the previous year, and generally there was deepening during the monsoon at that part of the bar. As in the previous year however the shoaling increased during the fair season, so that it had reached  $2\frac{1}{2}$  feet by the time that dredging was resumed. This may probably be ascribed to a temporary deposit of material scoured from within.

Dredging was resumed late in November, and was continued to the close of the season, with some interruption from want of funds.

Much shingle and boulders and some clay, also a patch of sand-stone rock were met with, and the aid of the divers was made use of in removal of boulders and blasting under water. Altogether 66,335 tons were dredged or removed during the season, improving the channel to 250 feet in width, having a depth of 17 feet along the middle, rising to 14 feet at either side.

The mouth of the Chinna Creek was contracted by raising the stone-bank to 5 feet over low water, and thus the flow through the "Notch" (widened to 270 feet) was considerably increased, which,—with some aid by training bunds and removal of hard material,—greatly benefitted the boat-channel, not however adding as yet appreciably to the main harbor ebb.

The surveys showed generally an improvement more marked than usual, the water-space having increased throughout from Kearnari to the sea.

The Government of India called (in 1870) for report as to the practicability of establishing a Port Trust at Kurrachee, so that the Harbor Works might be carried on by loan, repayable from the receipts of the Port. On this the Commissioner in Sind appointed a Committee, consisting of the principal Officials connected with the Port, and of representatives of the Mercantile and Railway interests, who reported that in the then incomplete state of the harbor, the revenue necessary for an Improvement Trust could not expediently be raised by additional port charges, and recommended that the question be postponed until the works in hand, which were of imperial interest, should be fully completed.

This report was approved and supported by Sir William Merewether.

In October 1870, Captain (now Major) Merewether, R.E., Executive Engineer, was promoted to the charge of the Bombay Defences, after a connection with the Kurrachee Harbor Improvements which, deducting nine months passed on Field Service, had lasted for nearly 10 years of devoted and skilful work.

1871-72.—Fair progress was made during this year, though a larger grant could advantageously have been expended with the means available, both as to plant and establishments.

The piece of breakwater built in 1870-71 stood the test of the heavy monsoon of 1871 very satisfactorily, though not without some slight displacement of blocks, due mainly to unequal settlement on the large boulders near the shore.

Block-making was carried on during the monsoon, and building was resumed on 16th October, making good the displacement of blocks and relaying the centre road, after which setting ahead was resumed, and 523 running feet built during the season, taking superstructure out to 793 feet from shore.

The improved progress of this season was mainly due to the greater strength of the diving party, and to aid given by one of the dredges in clearing the line of foundation, so that the "Titan" was enabled to work more nearly up to its full power. Even greater progress could have been made had more blocks been ready to set.

The quality of the concrete blocks proved all that could be desired.

Funds did not admit of more than 12,265 tons of the rubble-base being put in this season, and that chiefly a surface layer to check cross scour ahead.

The seaward angle at the shore end, which suffered slightly during the monsoon, was secured by the deposit of 3,000 tons of large and small stone, and 1,395 tons of large stone were deposited as a "toe" to the superstructure chiefly on the sea-side.

The dredged (west) channel proved of increased value, completely superseding the old (east) channel for both inward and outward vessels.

The channel stood the (unusually long and heavy) monsoon of 1871 satisfactorily, since though it shoaled about 2 feet at outer end, the extent of shoaling was less than in any previous year since the dredging was commenced.

Dredging was resumed on 23rd October, and continued—so far as funds permitted—to 15th March, giving a straight channel of 220 feet least width, and 17 feet least depth.

The divers were also employed towards the close of the season in removing boulders from outer end, also a patch of sand-stone rock near inner end of channel.

84,517 tons were dredged, and 180 tons of stone removed by divers during the season.

Some work was done during the monsoon at the removal of Deep Water Point by dredging sand and shingle, 18,735 tons, and blasting, and removing rock with aid of the divers, 1,639 tons.

Scour also gave good aid, having in addition removed 26,000 tons in five months.

The Chinna Creek mouth was further contracted by raising the stone bank  $1\frac{1}{2}$  feet, *i. e.*, to  $6\frac{1}{2}$  feet above low water, and the scour so diverted, aided by a few small draining bunds and removal of hard shoals, greatly enlarged the new channel, especially in the most important portion west of Napier Mole.

Observations made in December 1871 showed that the maximum discharge at the "Notch" had increased to 400,000 cubic feet per minute at  $\frac{1}{2}$  ebb, which however added only about  $\frac{1}{4}$  to the main harbor discharge.

The increase of flow on the latter part of the ebb was more marked, this being the chief agent in deepening the channel.

The harbor surveys were kept up as usual, and showed continuance generally of improvement, with some exceptions in a slight shoaling of the Keamari and Manora anchorages, and off end of East Pier, all however due to temporary or remediable causes, *i. e.*, to deposit from the Chinna Creek waters and cross rush of flood tide.

A change in the survey lines resulted in the discovery of a pinnacle of sand-stone rock off Deep Water Point with only  $16\frac{1}{2}$  feet depth over it at low water, but which has since been easily lowered to 20 feet.

This has been called after its discoverer, the "Morris" Rock.

Mr. Parkes arrived from England on a visit to the harbor and works on 19th September, 1871, and remained until 20th October, when he left for the Persian Gulf, again visiting the works on the 14th and 15th November on his way back to England. He had thus an opportunity of seeing the state of the Break-water after the monsoon before work had been resumed, and of seeing the block-making and afterwards the setting in full progress.

Mr. Parkes embodied his observations and conclusions from this visit in a report to the Secretary of State, in which his chief positive further recommendation was the pushing on of the dredging of the entrance channel at full power, while he advised that that the further extension of the East

Pier and removal of Deep Water Point be held in abeyance, and recommended the continuance of the measures in progress for the gradual diversion of the Chinna Creek waters.

1872-73.—Good progress was made during this year, ample funds having been supplied for the works in hand.

The half length of Breakwater stood the monsoon of 1872 satisfactorily, though not without some damage chiefly from unequal settlement on the large boulders.

On the 8th October, the "Titan" was moved out again, and after repair of monsoon damages (with some interruption from weather) started work ahead on 1st November, and by 22nd February built 710 running feet, completing the Breakwater to its full length of 1,503 feet (running into 5 fathoms water) within two years and four months, out of which only twelve months were actually occupied in setting.

It was with no small difficulty that the block-making and rubble base were kept apace with the building. 51,101 tons of base rubble, 2,493 tons of "toe," and 779 tons of angle foreshore were deposited during the season.

The successful completion of this work, and the services of the Engineers, and of the Staff\* employed on it, were honored by the favorable notice of the Secretary of State and the Governments of India and Bombay,† also especially so by Colonel Sir William Lockyer Merewether, K.C.S.I. and C.B., Commissioner in Sind, who watched the Breakwater during its progress, and has throughout supported and forwarded the Harbor Improvements.

The dredged channel benefitted during the monsoon of 1872 from the shelter of the half length of Breakwater, since though it shoaled two feet at outer end, the quantity of accumulation was less than in any previous monsoon.

This channel was now established as the main entrance to the harbor, and the Mail Steamers enabled to leave at a fixed hour, independent of tide. Ships also very rarely requiring the use of the Steam Tug. Dredging was resumed on 15th October, and continued vigorously to the close

\* Mr. George Lowe, Foreman of Masonwork; Mr. William Sangster, Foreman Engineer of Machinery; Mr. Bhumya Saenna, Supervisor; Mr. John Humby, Sub-Engineer.

† The total cost of the Breakwater, including proportion of plant, subsidiary works and superintending establishment, tallies almost exactly with Mr. Walker's estimate of £110,000, but the height was reduced  $7\frac{1}{2}$  feet and parapet omitted; also this work had the advantage of the organisation, training of workmen, and complete system of appliances, derived from the works previously carried out.

of the season, leaving the channel 175 to 350 feet wide at 20 feet depth, excepting two or three shoaler soundings (the least 18½ feet) near inner end of channel.

The quantity dredged during the season was 224,898 tons (of 20 cubic feet), including some shingle and stone, and 434 tons of boulders and rock were removed by the divers.

Some tendency to deposit was found during the fair season (especially in the inner half of the channel) ascribable chiefly to the cross rush of the flood-tide which takes a greater circuit since the construction of the Breakwater.

The diving party were employed during the monsoon in blasting and removing part of the shelf of rock and Deep Water Point, and the top of the "Morris" rock adjoining. 1,065 tons were taken out or rolled into deep water.

No further contraction of the Chinna Creek mouth was made during the year, but the scour continued—with some aid and guidance—to work well in the "New Channel."

Owing to changes in the Staff and to busy occupation on works, the Surveys were not kept up fully, but enough so to show that progress was generally satisfactory, the only exceptions being the partial shoaling in the Keamari anchorage and opposite end of East Pier, the former however decreased since last year.

A design for a New Light-house and Light (2nd Order Dioptric) to cost Rs. 31,762, was submitted in consequence of a call from the Commissioner in Sind, on the representations of the Master Attendant and of Ship Masters frequenting the Port, but sanction to this has not been accorded.

In May 1872 the harbor and works were visited by Mr. George Robertson, M. Inst., C. E., Harbor Engineer for India, who was deputed by the Government of India to report on the results already attained, and further to be looked for from the completion of the works.

Mr. Robertson remained in Kurrachee on this duty from 27th May to 7th June. In his report Mr. Robertson went very fully into the question, and his conclusion was that very beneficial results might be expected from the further small outlay anticipated at Kurrachee. He thinks that it would be obviously unwise to arrest or delay the progress of what is in reality the most important portion of the works after spending such a large sum on the improvement of the inner harbor, and the accommoda-

tion for native craft, and he believes that when the works are complete, the Government of India may be congratulated upon having an excellent harbor at Kurrachee.

The works were visited by His Excellency Lord Northbrook, Viceroy and Governor-General of India, when passing through Kurrachee on the 11th November, 1872, at which time the block-making and setting, and the dredging on the Bar, were in full progress.

1873-74.—During this official year, of which nine months have passed, the funds assigned have been more than sufficient for the works in hand, so that a considerable sum has been surrendered.

The completed breakwater stood the monsoon of 1873 very satisfactorily, losing only four blocks, all as on former occasions from the harbor-side top-course, and on the shore half length, where unequal settlement was caused by boulders.

The gaps have since been filled in with concrete, which it is expected will prove a permanent repair.

The outer half length built last season settled a good deal on its deep rubble base, but uniformly, so that no dislocation took place.

The shelter afforded by the Breakwater has so far proved ample, so that no further extension seems likely to be required.

The dredged channel showed the good effects of the completed Breakwater by keeping quite clear at the outer end, which in fact rather improved during the monsoon. At the inner end a shoaling of about one foot took place, caused probably by the cross rush of the flood-tide, yet the channel as left by the monsoon was found capable of passing on a medium tide (among other large vessels) the "Atalanta," a steamer of 385 feet in length, which left the port on the 26th September, drawing  $23\frac{1}{2}$  feet, and carrying upwards of 3,000 tons, chiefly wheat.

Dredging was resumed in October, and it is hoped this season to complete the channel to 500 feet in width, at 20 feet in depth, though this is involving the removal of a considerable quantity of hard material, including sand-stone rock, on which the divers are at work.

The diving party were employed during the monsoon of 1873 in blasting and removing rock at Deep Water Point to the extent of 280 tons, also they sunk some trial pits. A further trial was made of dredging on the Point for a fortnight, and 2,687 tons were removed, about three-fourths stone and shingle, but the work was very trying to the machinery.

The completion of the stoppage of the Chinna Creek mouth having been recommended by Mr. Parkes and sanctioned by Government, was commenced in May and completed in July. The diverted scour has continued to work well in the "New Channel," though some protection of the banks and direction and aid to the scour have been—and will further be—required.

The effect of the increased flow on the lower harbor cannot be precisely stated until the completion of the survey now in hand.

In consequence of the great improvement of the entrance, confirmed by the experience of the monsoon, the Acting Master Attendant submitted revised directions for the harbor (a copy of which accompanies, Appendix D.), which allow of the entry and departure of vessels of 24 feet draught during the fair season (October to 15th May), and of 21 feet "without difficulty or delay during all seasons of the year."

The draughts allowed in the former directions of 1860, before commencement of the Harbor Works (*see* Note, Appendix D.) were 19 feet 6 inches at springs, and 18 feet at neap-tides in the fair season, and in the South-West monsoon 17 feet at springs, and 15 feet at neap-tides, while it was added that "there are days during this monsoon when the sea on the Bar is so heavy that ships at the above draught could not with safety cross." Thus the revised directions already show a gain of 4 to 6 feet in depth over the former capabilities of the entrance channel, with the addition of shelter, and as the capacities for tonnage of vessels vary about as the cubes of their draughts, it may be said that the capabilities of the entrance in reference to tonnage have been more than doubled as regards the fair season, and more than trebled as regards the South-West monsoon, while owing to the directness of the channel, the Steam Tug is now very seldom required. The Mail Steamers are also enabled to leave at fixed hours, independent of tide; and detention of vessels off the port, and the sending of those of heavy draught to lighten at Bombay—so frequent in former years—are now unknown. Also owing to the shelter of the Breakwater, native craft can now enter and leave the port through the monsoon. At the same time it must be noticed that though the capacity of the harbor anchorage as regards vessels of moderate size has been nearly trebled,\* yet only a small number of vessels of a very large class could at present be berthed.

\* In the ratio of 55 ships to 20.



In this respect, however, the capabilities of the harbor would be largely increased by the works now under consideration for the removal of Deep Water Point and extension of the East Pier, and further anchorage space might be gained by dredging, if hereafter found necessary, while the material removed might be used for reclamation purposes.

Mr. Parkes, the Consulting Engineer, visited the harbor and works in November 1873, in the interval of his visits to Madras, and remained nearly a fortnight, during which time his attention was especially directed to the questions of completing the removal of Deep Water Point, and of extending the East Pier, which will no doubt be dealt with in his forthcoming report.

In April 1873 the works were visited by His Excellency Sir Bartle Frere, when passing through Kurrachee on his way from the Persian Gulf to Bombay.

*Cost of the Works.*—Having now brought the history of the undertaking up to the present date (December 1873), it will be convenient to give some particulars as to cost, which will be found in detail in Appendix E.

The total expenditure on the works up to the present date, taking into account value of plant, buildings, and land, is £389,126, of which about half has been expended on the works bearing immediately (as yet) on the improvement of the entrance and harbor anchorage, and half on those connected with the diversion of the Chinna Creek waters.

In addition to the above, the expenditure on Establishments is £60,672, amounting to 14 per cent. on the gross expenditure on works. The percentage has of course been enhanced by the two years' stoppage of active operations, and by the short supply of funds for works.

The balance remaining unexpended of the sanctioned Estimates is £28,319.

This is not likely to be all required for the works to which it belongs, especially in the case of the Manora Breakwater, but will be needed to complete the improvements thoroughly, by such works as extension of East Pier, removal of Deep Water Point, and dredging, to develop and maintain the improvement of the entrance and lower harbor, pending their attainment of a "regimen" under the effects of the Chinna Creek waters.

*Summary of results so far obtained.*—The results so far obtained as regards the improvement of the harbor, may be summed up as follows:—

The entrance has been deepened 6 feet and sheltered by the Breakwater, so that it is now declared capable of passing vessels of 21 feet draught during the South-West monsoon, and 24 feet during the fair season. The capabilities of the channel as regards tonnage of vessels are thus more than trebled as regards the South-West monsoon, and more than doubled as regards the fair season, during which the harbor is now accessible to vessels of the largest class, such as Her Majesty's Indian Troop Ships.

The Steam Tug is also now very seldom required, and detention and disappointment to large vessels are avoided.

Also native craft can now enter and leave the port throughout the entire year.

The harbor anchorage has been deepened, enlarged, and stilled by the construction of the Groyne and Breakwater, so that its capabilities as regards vessels of moderate size are nearly trebled, though as yet limited for very large vessels.

The accommodation for native sea-going craft and harbor lighters has been greatly increased by the construction of a jetty 1,400 feet in length, faced on each side with masonry walls, to which access is afforded by a channel  $1\frac{1}{2}$  mile in length, and 500 to 270 feet wide, which already is passable at all times of tide by all but the largest native sea-going craft, and is being further improved by the scour of the Chinna Creek waters.

Eastward of the jetty also the channel one mile in length—formed, and still improving—will afford valuable facilities for the extension of wharfrage hereafter in the vicinity of the Merchants' godowns.

If the trade has not increased as yet, as might be looked for from the expense incurred and facilities now available, it must be borne in mind that Kurrachee has of late years been placed at great disadvantage by the want of Railway communication; also that owing to the order in which the works were undertaken, and to delays in their prosecution, it has been only within the last four months that any substantial improvement of the entrance could be announced.

Further, the wharfrage accommodation, though provided eight years since, remained in great measure inaccessible until the diversion of the Chinna Creek waters began to improve the beat-channel within the last three years.

In fact the Chinna Creek diversion is as yet far from the full measure

of effect which it may be expected to produce on the upper harbor channels, and as regards its effect towards the first object contemplated by Mr. Walker from the diversion, namely, the improvement of the lower harbor and entrance, it cannot as yet be said to have even come into operation, since the early ebb is still impounded for the immediate benefit of the upper channels.

*Conclusion.*—In conclusion, it may be interesting to notice that up to the present time Mr. Walker's plans have in no case been departed from, except as regards the order and delay of their execution: and the only substantial additions made to them have been in supplementing the effect of scour on the Bar and at Deep Water Point.

The necessity for dredging on the Bar arose partly from the order in which the works were carried out, by which scour was brought to bear in anticipation of shelter, and partly from unlooked for difficulties caused by hard material, which last have been also felt at Deep Water Point.

These cannot however be called a very large addition to Mr. Walker's design, constituting as they do less than one-sixth of the entire expenditure.

As regards the total excess (about 60 per cent.) on Mr. Walker's original estimates, besides the items just noticed, this has already been partly accounted for in page 195, also it will probably have been gathered from the entire history of the undertaking that the cost has been enhanced by the order in which the works were carried out, by stoppage, and by delays in execution through short supply of funds.

Also the piecemeal mode of proceeding hampered the due working of the design, the parts of which were intimately connected, so that none of the works have as yet produced the full benefit which might have been long since obtained, had they been carried on steadily and as rapidly as consisted with economy.

All things considered, however, and in spite of mistakes and misunderstandings, the mention of which may be useful in reference to future large undertakings, it is submitted that the history of the Kurrachee Harbor Improvements may fairly be looked on as the record of a successful as well as interesting and important work, which is also by far the largest project of general harbor improvement, as yet undertaken in India.

W. H. P.

## APPENDIX A.

*Statements of depths of Kurrachee, Luckput, and Bombay.*

Distance from shore to seawards, in nautical miles.	DEPTH IN FATHOMS.			Remarks.
	Off Kurrachee or Western limit of Indus Delta,	Off Luckput or Eastern limit of Indus Delta.	Off Bombay.	
5	11	3	7	The Section off Bombay is given in order to compare the depths off Kurrachee with those of a well-known Port.
10	14	6	10	
20	27	10	20	
30	34	12	30	
40	42	15	36	
50	30*	14	41	
60	49	25	44	
70	67	49	47	
80	115	57	48	

\* The sounding of 30 fathoms at 50 miles off Kurrachee, occurs on an elevation on which, according to the Charts, "sand, shells, and coral" are found. These materials, and the general form of the elevation, show it to be a sub-marine hill, and not a bank of drift from the Indus.

## APPENDIX B.

*Value of Imports and Exports at Kurrachee from 1843-44 to 1873-74.*

Year.	Imports.	Exports.	Total Value.	Remarks.
	Rs.	Rs.	Rs.	
1843-44, ...	11,50,925	9,595	11,60,520	
1844-45, ...	20,68,150	88,350	21,56,500	
1845-46, ...	29,72,550	3,84,750	33,57,300	
1846-47, ...	27,87,300	4,68,350	32,55,650	
1847-48, ...	27,34,784	14,69,943	42,04,727	
1848-49, ...	32,74,800	10,17,772	42,92,572	
1849-50, ...	39,83,852	10,86,594	50,70,446	
1850-51, ...	40,45,401	18,66,387	59,11,788	
1851-52, ...	46,47,592	23,19,167	69,66,759	
1852-53, ...	50,89,063	35,75,207	86,64,270	
1853-54, ...	48,33,537	35,74,952	84,08,489	
1854-55, ...	54,64,369	32,95,489	87,59,858	
1855-56, .	59,83,228	57,42,183	1,17,25,411	
1856-57, ...	65,13,825	69,77,961	1,34,91,786	
1857-58, ...	1,02,70,462	1,02,42,222	2,05,12,684	
1858-59, ...	1,46,35,755	99,20,590	2,45,56,345	
1859-60, ...	1,62,71,142	89,99,691	2,52,70,833	
1860-61, ...	1,57,88,252	97,56,423	2,54,94,675	
1861-62, ...	1,51,85,667	1,15,34,862	2,66,70,529	

## MEMOIR OF KURRACHEE HARBOR.

Year.	Imports.	Exports.	Total Value.	Remarks.
	Rs.	Rs.	Rs.	
1862-63, ...	2,18,89,487	3,12,74,812	5,31,64,249	} Great increase in value of export of Cotton owing to American War.
1863-64, ...	2,52,08,979	4,04,67,871	6,56,76,850	
1864-65, ...	2,37,21,986	2,80,22,887	5,17,44,873	
1865-66, ...	2,08,45,633	2,81,18,434	4,84,64,067	
1866-67, ...	2,68,24,474	2,07,31,178	4,75,55,652	
1867-68, ...	2,43,87,130	1,76,48,978	4,20,36,108	
1868-69, ...	2,18,41,075	1,79,23,746	3,97,64,821	
1869-70, ...	2,05,63,181	1,88,79,341	3,97,42,522	
1870-71, ...	1,80,66,121	1,88,98,898	3,69,64,519	
1871-72, ...	1,61,88,563	2,24,87,324	3,86,75,887	
1872-73, ...	1,62,24,255	1,74,76,506	3,37,00,761	
1873-74, ...	1,18,48,121	1,41,17,863	2,59,65,484	For 9 months ending 13 <sup>th</sup> Dec. 1873

*Realizations on account of Sea Customs Revenue of Kurrachee from  
1846-47 to 1873-74.*

Year.	Import duty.	Export duty.	Miscellaneous.	Total realizations.	Remarks.
	Rs.	Rs.	Rs.	Rs.	
1846-47, ...	50,514	13,478	331	64,313	
1847-48, ...	27,728	9,941	484	38,153	
1848-49, ...	28,620	5,361	1,128	35,109	
1849-50, ...	22,031	6,510	732	29,273	
1850-51, ...	14,794	13,034	1,516	29,344	
1851-52, ...	13,274	17,281	588	31,141	
1852-53, ...	15,084	13,081	785	28,900	
1853-54, ...	17,025	6,505	590	24,120	
1854-55, ...	15,808	14,683	811	31,302	
1855-56, ...	16,065	10,350	41,612*	68,027	* Includes 32,993 as Salt Excise.
1856-57, ...	53,911	19,484	916	74,311	
1857-58, ...	54,165	26,114	5,500	85,779	
1858-59, ...	1,06,379	46,420	42,180	1,94,929	36,504 Salt Excise.
1859-60, ...	3,45,883	51,558	21,554	4,18,995	13,919 "
1860-61, ...	3,09,981	1,54,287	51,806	5,15,574	42,985 "
1861-62, ...	4,01,457	94,552	1,20,872	6,16,881	1,16,879 "
1862-63, ...	2,36,649	1,40,489	1,05,155	4,82,293	89,350 "
1863-64, ...	1,97,664	2,08,158	10,554	4,16,376	
1864-65, ...	1,87,812	1,35,732	19,282	3,42,826	15,428 "
1865-66, ...	2,15,699	1,19,730	4,105	3,39,534	237 "
1866-67, ...	2,31,107	1,24,074	3,903	3,59,088	22 "
1867-68, ...	3,01,694	1,04,020	5,672	4,11,386	
1868-69, ...	3,25,178	1,12,604	4,629	4,43,411	
1869-70, ...	3,08,030	88,814	4,901	4,01,745	
1870-71, ...	2,46,000	72,078	3,878	3,21,951	
1871-72, ...	2,45,069	1,45,212	5,008	3,95,289	
1872-73, ...	2,30,488	1,00,852	5,326	3,36,666	[31 <sup>st</sup> Dec., 1873.
1873-74, ...	1,67,382	63,910	2,497	2,33,789	For 9 months ending

In the returns available from the Customs Department the value of Trade and Customs realizations of the small river ports of Khetty and Seirgunda were included in those of Kurrachee up to 1860-61, and on this account a deduction of 5 per cent. has been made in the value of Trade, and 10 per cent. on that of Customs realizations, being the proportion found to exist on the average of the 13 years from 1861-62 to 1873-74, during which the returns of the smaller ports have been kept separate.

## APPENDIX C.

*Statement of Vessels wrecked at or near the Harbor of Kurrachee, since commencement of British intercourse with the Port.*

Name of Vessel.	When wrecked.	Remarks.
Ship "Julia," .. ..	1857	Wrecked near the Oyster Rocks through cutting of hawser while being towed to sea through the East Channel in S. W. Monsoon.
Ship "Admiral Boxer,"	1857	Wrecked on the Indus banks near the Pitty mouth, 12 miles from Kurrachee, on her passage from Cardiff.
Ship "Stamboul," .. ..	1859	Wrecked in S. W. Monsoon 8 miles West of Manora, having run on shore through want of a proper look-out while waiting off and on for water to enter the Port.
Steamer "Indus," .. ..	1860	Sunk when crossing the Bar, through starting of stern articulation, on meeting ocean swell. This was one of the "Train" Steamers of the Oriental Inland Steam Navigation Company.
Ship "Marina," .. ..	1861	Wrecked 2 miles West of Manora, under circumstances similar to those of the "Stamboul."
Steamer "Talpoor," .. ..	1864	Broke up on meeting ocean swell on her first trip from Kurrachee to the Indus, put back and sunk near the Oyster Rocks.
Ship "Alicia," .. ..	1868	Wrecked on Bar at site of present entrance channel, having been disabled, by a heavy sea when making the Port in S. W. Monsoon.
Ship "Bacchante," .. ..	1870	Run ashore near the Oyster Rocks for partial salvage, having put back to Kurrachee in a sinking state, and not found water sufficient to enter the Port.

NOTE.—In addition to the above, the Ships "Thomas Campbell," "Augusta," "James Child," and "Richmond," and Steamer "Pioneer," grounded on the Indus Banks, but were eventually floated off.

Two large Troop Steamers also touched on them.

## APPENDIX D.

*Notice to Mariners.—Directions for Kurrachee Harbor, 1873.*

## LIGHT-HOUSE.

Latitude of Light-House on Manora Point 24° 47' 21" N.

Longitude .. .. . 66° 58' 15" E.

The light is a fixed one, 120 feet above the

Sea Level—visible in clear weather .. 16 Miles.

In the hazy weather, prevalent during the

South-West Monsoon—about .. .. 7 "

NOTE.—It is hoped that this Light will be shortly replaced by a Dioptric Light of the 2nd Order, for which designs have been submitted.

## TIDES.\*

	H. M.
High water, full and change .. ..	10 30
Average rise and fall—Spring Tides ..	9 ft. 6 in.
Do. do. Neap Tides .. ..	3 to 4 feet.

## AVERAGE DEPTH OF WATER ON THE BAR AT HIGH WATER.

Springs Tides ... ..	28 feet.
Neap Tides .. ..	25 to 26 feet.

## DRAUGHT OF VESSELS ENTERING OR LEAVING PORT.

Vessels with a draught not exceeding 21 feet, can now enter and leave port without any difficulty or delay during all seasons of the year.

During the fair season, from *October to 15th May*, vessels of the largest class, with a draught not exceeding 24 feet, can now enter and leave the Harbor. Fixed moorings will be placed for such vessels.

## APPROACHES.

Ras Muari (or Cape Monze), distant 18 miles W.  $\frac{1}{2}$  N. from the Western entrance to Kurrachee, is high and bold of approach. Ships during the S. W. Monsoon season should make this headland, running to the Eastward for Manora Point, keeping it (Manora Point) on any bearing to the North of East.

Masters of Ships should endeavour to make the Port at daylight, and can with safety approach to within from 1 to 2 miles distance from the Light-House, keeping it, on any bearing, from N. E. to North, and heave to for a Pilot.

## TIME OF TIDE FOR ENTERING PORT.

Sailing Vessels should enter Port on the ebb-tide.

Steamers can enter either on flood or ebb, and stand at once into Port.

\* Directions for 1860.

	TIDES.	
	Spring.	Neap.
Average depth of water on the bar at high water, ... ..	Feet. 21 to 22 $\frac{1}{2}$	Feet. 18 to 19
South-West Monsoon, ... ..	17	16
Fair Season, ... ..	19 $\frac{1}{2}$	18

Masters of Ships should not, under any circumstances, attempt to enter the Harbor without a Pilot.

#### HARBOR IMPROVEMENTS.

The Harbor Works are nearly completed, and have proved most successful, both as regards deepening the entrance channel and enlarging interior accommodation for Shipping.

Among the extensive works executed, a Breakwater has been built, running out from Manora Point in a S. by E. direction to a distance of 1,500 feet, into 6 fathoms of water; this affords complete shelter to the Channel over the Bar during the S. W. Monsoon.

Also a Channel has been opened through the Bar with a depth of 19 feet at low water spring-tides, 300 feet in breadth (to be widened to 500 feet); the Channel is marked with buoys, and these on entering should be kept on Port side, about 100 feet.

NOTE.—Every facility will be afforded (during the fair season only) for Mail Steamers to enter Port during the night. A "red light" will be placed at the end of the Breakwater, and a light will be shown on west side of channel.

A Mail Steamer arriving off the Port at night and requiring a Pilot, should fire "two guns."

GEO. C. PARKER, LIEUT., I. N.,  
*Acting Master Attendant, Kurrachee.*

MANORA,  
MASTER ATTENDANT'S OFFICE, }  
23rd August, 1873.

NOTE.—The foregoing new directions were published in the "Bombay Government Gazette," Part II., of 19th February, 1874, page 117.



## APPENDIX E.

*Statement of Expenditure from the commencement and up to 31st  
December, 1873.*

Name of Work.	Amount of Sanc- tioned Estimate.	Expendi- ture up to 31st De- cember, 1873.	Remarks.
<i>1st series of sanctions.</i>			
	£	£	
Keamari Groyne ... ..	30,175	30,175	Completed.
Napier Mole Bridge ... ..	49,142	49,006	"
Native Jetty and Quays ... ..	43,733	43,061	"
New Channel ... ..	62,543	62,138	Some work remaining in training and aiding scour.
Chinna Creek Stoppage ... ..	18,829	18,827	Completed.
<i>2nd series of sanctions.</i>			
East Pier or continuation of Keamari Groyne ... ..	18,149	18,142	Completed so far as sanctioned.
Manora Breakwater ... ..	82,633	69,498	" except some additional fereshore rubble.
Deep Water Point Removal	25,584	19,399	Completed, held in abeyance.
<i>Subsidiary works.</i>			
Plant and Tools ... ..	79,959	73,027	
Office, Workshop, and Store-yard at Kurrachee	4,910	4,910	Completed.
Office, Workshop, and Store-yard at Manora ... ..	8,512	8,231	" except maintenance.
Repairs to Quarters ... ..	558	350	In hand.
Harbour Surveys ... ..	4,811	4,455	Do.
<i>Extra sanction.</i>	429,538	401,219	
Bar Dredging ... ..	...	25,907	In hand.
Total, ... ..	429,538	427,126	Estimated value of plant and tools after completion of works..... £15,000
<i>Deduct—</i>			
Per details in last Column	...	38,000	Land filled in with material from new channel, 44 acres, 1,845 yards, at 1 rupee per square yard..... £21,500
Difference ... ..	...	389,126	Materials of buildings and piers, and well of sweet water at Manora..... £ 1,500
<i>Add—</i>			
Establishment for Superin- tendence ... ..	...	60,672	£38,000
Grand Total, ... ..	...	449,798	

No. CXVIII.

---

CHIEF COURT AT LAHORE.

[ *Vide* Plates XLIII. to XLVIII.]

---

*Designed by* W. PURDON, Esq., M. INST. C.E., F.G.S., *Supdg. Engineer.* *Estimate by* RAI KUNHYA LAL, *Assoc. Inst. C.E., Exce. Engineer.*

---

MEMO. ON THE PROPOSED CHIEF COURT AT LAHORE.

THE object of constructing this building is to provide suitable accommodation for the Chief Court which has been established at Lahore, the building in which the Court is now held, being temporary only, while it affords no accommodation for the Pleaders and others who have to attend the Court.

The general plan was prepared in communication with the Judges, and has been approved of by Government.

The style of architecture selected is the Gothic-Arabic of the 14th century, of which style Venice affords some of the most splendid and best known examples.

It is believed that it is especially well fitted for India, the arcades giving the shade which is indispensable, while at the same time affording ample means for lighting and ventilating, being, moreover, highly ornamental.

The great drawback to verandahs, in general, at least in the remarkably dry heat of the Punjab, is that they retain the heat long after the sun has gone down, and when the temperature of the surrounding atmosphere has cooled considerably; rendering it impossible to open any of the doors

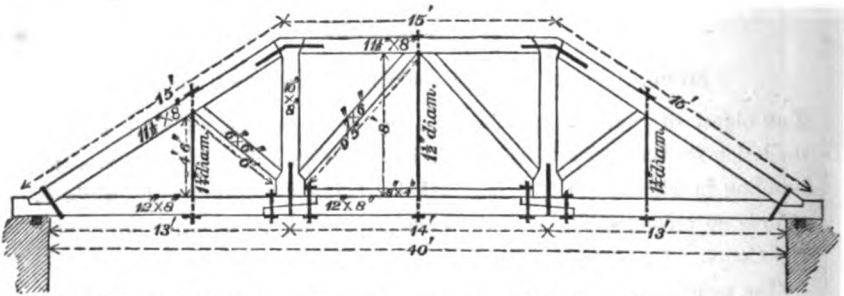
or windows of the main building which open into them. In the Gothic-Arabic style the open tracery work of the upper portion of the arcade affords ample means by which, the heated air, accumulated during the day, can pass off, while the actual protection to the walls of the main buildings is almost as perfect as in the ordinary verandah; the arcades are, moreover, better lighted, and this is a great advantage, when it becomes necessary to light the rooms from the verandahs.

The specification and estimate which accompany this, have been prepared by Rai Kunhya Lall, Executive Engineer, Lahore, who has already completed several important civil buildings there, in a very creditable and satisfactory manner.

W. P.

CALCULATIONS OF SCANTLINGS FOR THE MAIN TIMBERS OF PITCHED AND FLAT ROOFS OF THE NEW CHIEF COURT, LAHORE.

I. *Pitched roof of court room. Span 40 feet. Roof covering, slates. Section of truss as below:—*



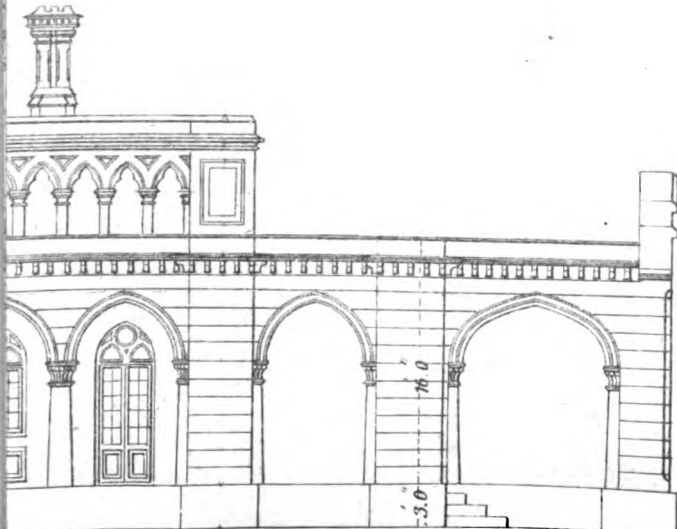
Interval from centre to centre of trusses = 6.2 feet; weight per foot of roof = 200 lbs., (including pressure of wind, weight of ceiling, and of other wood work, &c., &c.) Then,

Strain in the direction of each of the two queen-posts, is,	.. ..	= $\frac{1}{2} (45 \times 6.2 \times 200 \text{ lbs.})^*$	= 27,900 lbs.
Strain on principal rafter, .. ..	.. ..	= $27,900 \times \frac{15}{8}$	= 52,312 "
.. tie-beam, or straining beam,	.. ..	= $27,900 \times \frac{13}{8}$	= 45,357 "
.. queen-posts, .. ..	.. ..	= 27,900	= 27,900 "

\*  $S = \frac{1}{2} W + \text{weight of truss and ceiling, \&c.}$

=  $\frac{1}{2} W + \frac{1}{2} W$  ( $\frac{1}{2} W$  being taken equal to weight of truss and ceiling, &c.)

=  $\frac{1}{2} W = \frac{1}{2} (45 \times 6.2 \times 200 \text{ lbs.})$





Strain on large tie-rod,	..	..	=	$15 \times 62 \times 200 \times \cdot 625$	=	11,625 lbs.
„ on small ones,	..	..	=	Ditto	=	11,625 „
„ on large braces,	..	..	=	$11,625 \times \frac{9\cdot5}{8}$	=	13,804 „
„ on small „	..	..	=	$11,625 \times \frac{6\cdot}{4\cdot5}$	=	15,500 „
„ on straining sill,			=	$11,625 \times \frac{4\cdot5}{4\cdot5}$	=	11,625 „

The safe co-efficient for pressure of deodar wood, being 700 lbs. per square inch, the sectional area of principal rafter, .. =  $\frac{52812}{\frac{5}{6} \text{ of } 700}$  lbs. = 89.72 square inches.

Ditto of each queen-post, .. =  $\frac{27900}{\frac{1}{2} \text{ of } 700}$  „ = 79.71 „

Ditto of tie-beam or straining beam, =  $\frac{45,337}{\frac{5}{6} \text{ of } 700}$  „ = 77.76 „

Ditto of straining sill, .. =  $\frac{11,625}{\frac{5}{6} \text{ of } 700}$  „ = 19.94 „

Ditto of large brace, .. =  $\frac{13,804}{\frac{1}{2} \text{ of } 700}$  „ = 39.44 „

Ditto of small „, .. =  $\frac{15,500}{\frac{5}{6} \text{ of } 700}$  „ = 26.58 „

Diameter of tie-rods, .. =  $\sqrt{\frac{11,625}{7,854}}$  „ = 1.25 inches.

The purlins will be 3 feet from centre to centre, the strain on them will be equal to  $6\cdot2 \times 3 \times 200 \times \cdot 625 = 2,325$  lbs.

To resist this strain, the purlin should be  $8'' \times 4\cdot5''$ , the strength of which is  $\frac{8^2 \times 4\cdot5 \times 500}{10 \times 6\cdot2} = 2,322$  lbs.

The common rafters, which will be one foot from centre to centre, may be  $3'' \times 2''$ .

The scantlings of the various timbers and iron tie-rods of the roof, are, therefore, fixed as follows:—

Principal rafters,	..	..	..	$11\frac{1}{4}'' \times 8''$
Straining beam,	..	..	..	$11\frac{1}{4}'' \times 8''$
Tie-beam (to support the ceiling, and also to allow for joints at the feet of the rafters),				$12'' \times 8''$

Queen-posts,	..	..	..	..	10" x 8" in the middle.
Large braces,	..	..	..	..	7" x 6"
Small do.,	..	..	..	..	6" x 6"
Straining sill,	..	..	..	..	8" x 4"
Tie rods large,	..	..	..	..	1.5" diameter.
„ small,	..	..	..	..	1.25 „
Purlins,	..	..	..	..	8" x 4½"
Common rafters,	..	..	..	..	3" x 2"

*II. Flat terrace roof of rooms, 20 feet span.*

Interval from centre to centre of beams = 4.5 feet.

Weight of roof per s. ft. = 100 lbs.

Then, strain at centre of each beam

$$= 20 \times 4.5 \times 100 \times .625^* = 5,625 \text{ lbs.}$$

Strength of beam of 16" x 10" scantlings =  $\frac{16^2 \times 10 \times 500}{10 \times 20} = 6,400 \text{ lbs.}$

*III. Flat terrace roof of large porches, 18 feet span.*

Interval from centre to centre of beams = 5.33 feet.

Weight per s. ft. of roof = 100 lbs.

Then, weight acting at centre of each beam

$$= 18 \times 5.33 \times 100 \times .625 = 5996.25 \text{ lbs.}$$

Strength of beam 16" x 10" scantling =  $\frac{16^2 \times 10 \times 500}{10 \times 18} = 7,111 \text{ lbs.}$

*IV. Flat terrace roof of rooms, 17½ feet span.*

Interval from centre to centre of beams = 3.78 feet.

Weight per foot of roof = 100 lbs.

Then, weight acting at centre of each beam

$$= 17.5 \times 3.78 \times 100 \times .625 = 4134.375 \text{ lbs.}$$

Strength of beam of 16" x 8" scantling =  $\frac{16^2 \times 8 \times 500}{10 \times 17.5} = 5,851.46 \text{ lbs.}$

*V. Flat terrace roof of rooms, 15 feet span.*

Interval from centre to centre of beams = 4 feet.

Weight per s. ft. of roof = 100 lbs.

Then, strain at centre of each beam

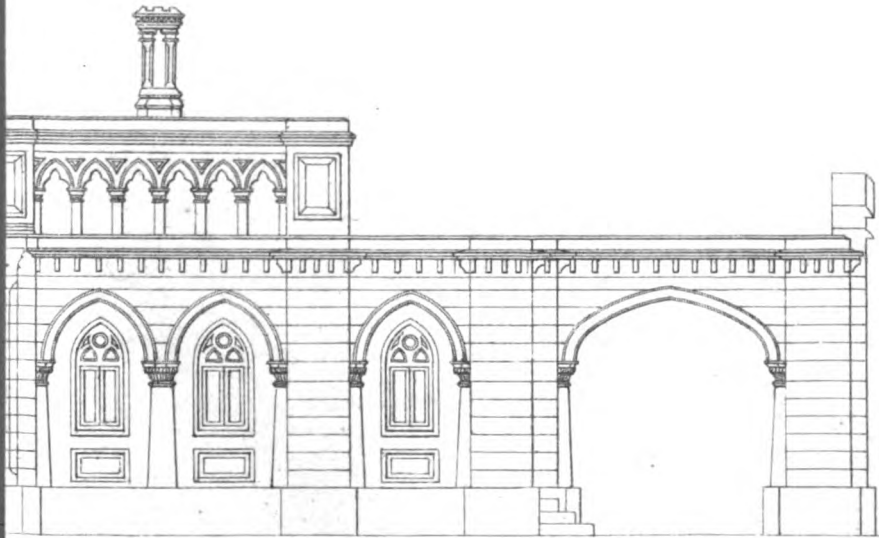
$$= 15 \times 4 \times 100 \times .625 = 3,750 \text{ lbs.}$$

Strength of beam of 14" x 7" scantling =  $\frac{14^2 \times 7 \times 500}{10 \times 15} = 4,573 \text{ lbs.}$

\* S = ½ W + weight of beam.

= .5 W + .125 W (weight of beam being taken equal to .125 W).

= .625 W.







*VI. Flat terrace roof of small porches, 12 feet span.*

Interval from centre to centre of beams = 4 feet.

Weight per s. ft. of roof = 100 lbs.

Then, strain at centre of each beam

$$= 12 \times 4 \times 100 \times \cdot 625 = 3,000 \text{ lbs.}$$

$$\text{Strength of beam of } 12'' \times 6'' \text{ scantling } = \frac{12^2 \times 6 \times 500}{10 \times 12} = 3,600 \text{ lbs.}$$

*VII. Flat terrace roof of verandahs, 10 feet span.*

Interval from centre to centre of beams = 4 feet.

Weight per s. ft. of roof = 100 lbs.

Then, strain at centre of each beam

$$= 10 \times 4 \times 100 \times \cdot 625 = 2,500 \text{ lbs.}$$

$$\text{Strength of beam of } 10'' \times 6'' \text{ scantling } = \frac{10^2 \times 6 \times 500}{10 \times 10} = 3,000 \text{ lbs.}$$

*VIII. Kurrees for rooms where beams are 3 to 4 feet apart.*

Interval from centre to centre of kurrees = 1 foot.

Weight per s. ft. of roof = 100 lbs.

Then, strain at centre of each kurree

$$= 4 \times 1 \times 100 \times \cdot 625 = 250 \text{ lbs.}$$

$$\text{Strength of kurree } 4'' \times 3'' = \frac{4^2 \times 3 \times 500}{10 \times 4} = 600 \text{ lbs.}$$

*IX. Similarly,*

Strain on kurrees over beams 5 feet apart

$$= 5 \times 1 \times 100 \times \cdot 625 = 312\cdot 5 \text{ lbs.}$$

$$\text{Strength of kurree } 5'' \times 3'' = \frac{5^2 \times 3 \times 500}{10 \times 5} = 750 \text{ lbs.}$$

*X. Trussed roof of tower.*

Weight of roof acting vertically at the apex of each of the eight rafters

$$= \left( 4 \times \frac{12 \times 10}{2} \times 200 \right) \frac{1}{8} = 6,000 \text{ lbs.}$$

$$\text{Strain on rafter} = 6,000 = \frac{10}{7} = 8,571 \text{ lbs.}$$

$$\text{,, on tie-beam} = 6,000 \times \frac{6}{7} = 5,143 \text{ lbs.}$$

$$\text{Sectional area of rafter} = \frac{8571}{\frac{1}{4} \text{ of } 700} = 24 \text{ square inches.}$$

$$\text{,, of tie-beam} = \frac{5143}{\frac{1}{4} \text{ of } 700} = 14 \text{ square inches.}$$

The rafters may, therefore, be 6" × 4" and the tie-beam 5" × 4".

Purlins for the above may be 7" × 4", 2 to 3\* feet apart, and common rafters 3" × 2", one foot from centre to centre.

*Description of plan, &c.*—The plan of the new Chief Court provides two large Court Rooms, each 62 feet × 40 feet, connected by a Hall 30 feet diameter. On both sides of the court rooms, are the English and Vernacular Offices, with Record Rooms, Jury Room, Pleaders' Room, Witness Room, and Judges' Retiring Room; at the four corners of the hall, there are four small rooms in the lower story, which are converted into two in the upper floor, access to which is provided by means of stair-cases, shown in plan.

In the front of the building is a large Carriage Porch, 32 feet × 18 feet (interior measurements), and between it and the hall is a Tower 8 feet square inside, and 17 feet square outside, and 82 feet in height to the top of the iron finials. This tower is to have a large clock in it, in front, as shown in the front elevation. At the back of the court rooms are rooms for three judges, with bath rooms in the rear verandah, Registrars', Deputy Registrars', Committee Room, Bar Library, and Court Library. Each of these rooms is  $22\frac{3}{4}$  ×  $17\frac{1}{2}$  feet; and a passage 12 feet wide separates them from the court rooms. A verandah, 10 feet wide, which contains all the bath rooms, &c., is provided all round the building. There is also a carriage porch at the back, similar to that in the front, and two small porches on either side opposite the corridor or passage; a passage 8 feet wide connects the hall with the front and rear porches.

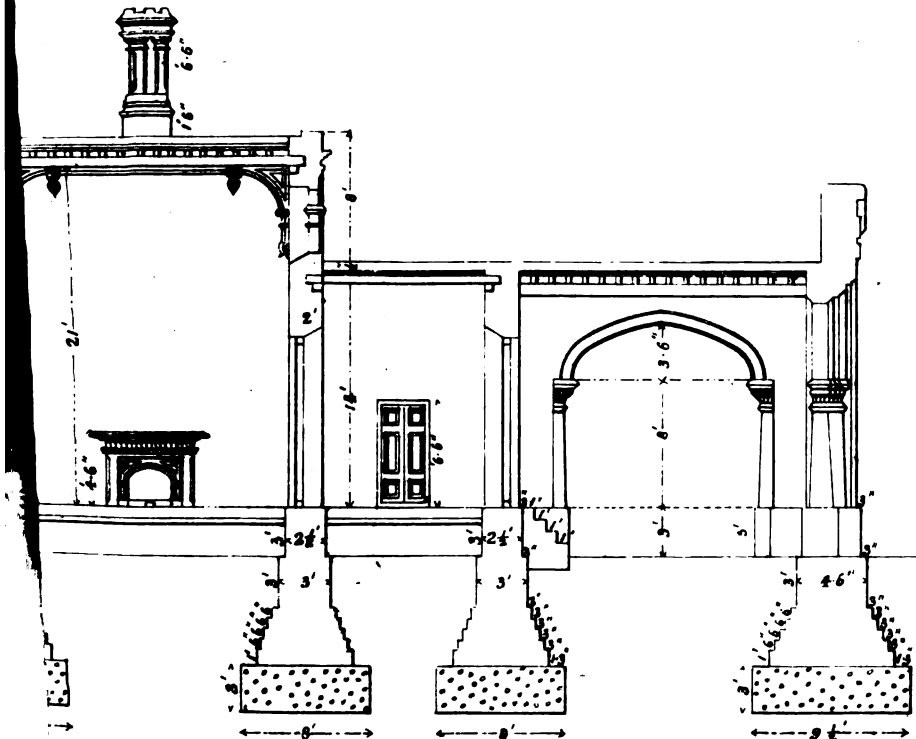
The building measures 235 feet × 127 feet, outside dimensions, (besides the porches,) and its style is Venetian-Gothic.

The motto selected for the Building "*Justitia Regnorum Fundamentum*," is to be executed in white and black marble, over the main entrance of the building, as shown in *Plate XLIII*.

The out-houses are as follows:— One shed for 100 suiters, a godown and police-guard room, six servants' houses, and stalls for six horses, and four coach-houses. There is also a new pukka well to be sunk in the compound, and the approaches leading to the court are to be metalled with kunkur.

Dimensions of all the buildings are marked on the plans accompanying.

\* The interval between purlins to be 2 feet at the foot of the rafters, to be increased gradually, till it is 3 feet at the apex.





*Specification of work. Foundations.*—The foundations to be properly excavated to the depth of 9 feet below the surface of the ground. The soil of the site consists of about 6 feet of loose earth, and sand below that, to a great depth; it is, therefore, proposed to make the foundations 9 feet deep, of which 5 feet will be of concrete work, and 6 feet of pukka masonry. The foundations to be excavated 6 inches wider, on both sides, than the brickwork, and to be carefully dressed and levelled. Three feet of concrete (consisting of 2 parts of gravel and 1 part of good fresh burnt kunkur lime, well mixed in the dry state, then watered and turned over with shovels) to be given in the foundations, in layers of about 9 inches each, well watered and rammed till they get thoroughly consolidated; each successive layer being given while the lower one is wet. The top layer to be properly levelled for masonry of foundations, which is to be pukka, of small bricks laid in good kunkur lime mortar. Foundation masonry to be 6 feet deep, and 6 inches wider on both sides than the breadth of the walls in superstructure. The bricks to be well soaked in water immediately previous to being used. After the masonry of the foundations is finished, the extra space dug on both sides of the walls, to be carefully filled with earth, *well rammed*, so as to leave no hollows close to the foundations. Foundations of steps to be one foot below the soil on a layer of one foot of concrete.

*Plinth.*—After the foundations are completed as described above, the thickness of walls in the plinth to be accurately marked on the top of the foundations, and the masonry of the plinth to be executed as follows:—Plinth of inner walls to be entirely of small pukka bricks laid in good kunkur lime mortar, and that of the outer walls, of small bricks faced with large pukka ( $9'' \times 4\frac{1}{2}'' \times 3''$ ) bricks, laid in mortar made of 9 parts of best fresh burnt kunkur lime, mixed with 1 part of good stone lime, and the whole well ground in a mill. The upper  $4\frac{1}{2}$  inches of plinth to be brick-on-edge, close jointed, under the outer archways and doors. The large bricks for the facing, to be well burnt, picked, and well shaped, and to be thoroughly soaked in water immediately previous to being laid in the wall. The face work of large bricks to be in Flemish bond, with close and straight joints.

*Steps.*—Steps to be of large pukka ( $9'' \times 4\frac{1}{2}'' \times 3''$ ) bricks, well burnt, and properly shaped, and laid on edge in fine lime mortar (same as for the face work of plinth), with close joints.

*Superstructure.*—In the superstructure, all the inner walls are to be of pukka masonry of small bricks, and the outer ones (with the exposed parts of inner ones above the verandah roofs) of small bricks, with layers of large bricks at every 3 feet in height, and outside faced with large bricks, same as the plinth. The pillars and arches, and all thin walls are to be *entirely* of large bricks, which are to be thoroughly burnt of a cherry red color, well shaped; and in Flemish bond, with straight joints, not exceeding  $\frac{1}{4}$ th of an inch in thickness. The outer mouldings and cornices, &c., to be properly executed in brickwork, as per plan. The bricks to be thoroughly soaked in water, and mortar to be of the same description as for the plinth and steps. Every course of brickwork to be well grouted and every day's work to be flooded with water in the evening. The tops of unfinished walls to be at all times kept covered with water, till they are finished. No interstices are to be left in the inside of the walls, and no brick-bats are to be used in the brickwork. The bricks for the facework to be of a uniform deep red color, and no peela or vitrified bricks to be used; the courses of brickwork to be truly level, both longitudinally and transversely, and the faces of the walls to be perfectly plumb. The whole of the brickwork to be executed in a workmanlike manner, and the walls to be carried on at a uniform level, to such extent as the nature of the work may permit. Wherever a break has to be unavoidably left, it is to be left in steps, so that it may be joined on to fresh work properly. The dome of the hall to be carefully built of large pukka bricks laid in good kunkur and stone lime mortar, in the proportion of 6 parts of the former to 1 of the latter, and the mouldings, pillars, and recesses of the inside of the dome and the hall to be roughly executed in brickwork, and finished neatly in plaster, rubbed smooth.

The parapets, chimney shafts, and railings of the archways of upper story of front verandah of the building, to be carefully and neatly executed in brickwork as per plan.

*Floors of lower rooms.*—The floors of lower rooms and verandahs consist of well burnt flat tiles  $12'' \times 12'' \times 2\frac{1}{2}''$ , carefully shaped, and laid in fine lime mortar, with close joints, and the whole rubbed smooth and nice; the tiles of the floor to rest over 9 inches of concrete well rammed.

*Floors of upper rooms and verandahs.*—The floors of upper rooms in front and rear of dome, and of the upper front verandah on both sides of the tower, to be arched, 1 foot thick, of large pukka bricks laid in mortar

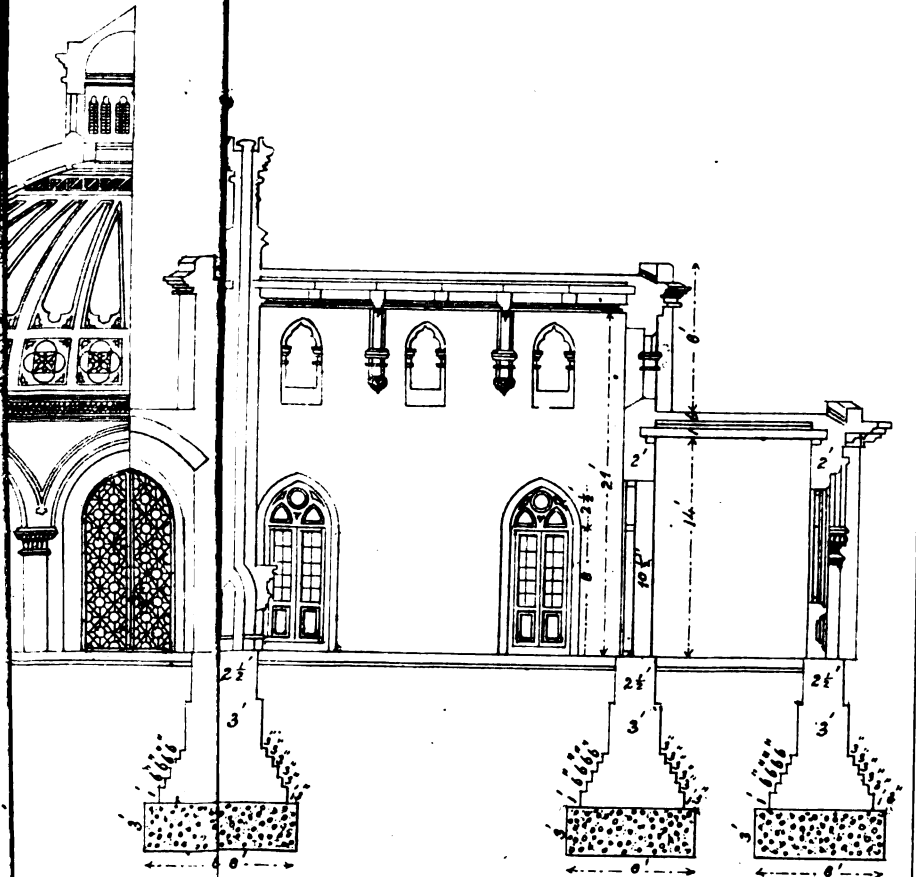
# Court,

M. Inst. C.E., F. C.

Scale, 12 feet to an

10

2



DINAL SECTION







(same as for the dome) and covered with 3 inches of lime terrace properly beaten.

*Floors of tower.*—The ground floor of the tower to be tiled, same as that of lower verandahs and rooms, the second floor to be arched, the third to be wooden, of deodar wood kurrees 6" × 4", laid one foot from centre to centre, and covered with boards 1½" thick. The 4th and 5th floors of the tower, to be of lime terrace 4" thick (beaten to 3 inches), over 12" × 6" × 2½" pukka roofing bricks, resting on deodar wood kurrees 6" × 4", laid 1 foot from centre to centre.

*Pitched roofs.*—The roof of the court rooms and of the tower, to be of slates, 24" × 12", laid with an overlap of 8 inches on deodar wood planking 1 inch thick, over battens 3" × 2", one foot from centre to centre, resting on purlins and trusses of the same wood. The trusses to be constructed as per plan, and the scantlings of the timbers, and the diameters of the iron tie-rods, forming the trusses, to be as per sheet of calculations annexed. The wall plates under the ends of the trusses to be 10" × 6" and the whole of the woodwork to be of the heart of well seasoned deodar wood, free from large knots and flaws. The roof of the tower to terminate in an iron finial, as per plan.

*Arched roof.*—The roof of the upper rooms in the front and rear of the hall, of the upper verandahs on both sides of the tower, and of the corridor, and the small passages, is to be arched, of large pukka bricks laid in lime mortar, same as for the arched floors of those rooms, &c., the thickness of the arched roof to be one foot, and the haunches to be filled up with pukka masonry level with the top of the arch. Lime terrace, 3 inches thick, well beaten, to be given over the top of the roof, same as over the arched floor.

*Dome over the hall.*—The hall is to be covered with a semi-circular dome of pukka masonry of large bricks; thickness of dome to be 2 feet, and the haunches to be filled up with pukka masonry of small bricks to within 3 feet of the top of the dome, and sloped off, as shown on the section. The top of the dome to be surmounted with a lantern of pukka masonry, having its openings fitted with wire gauze or net work of thin iron wires, for purposes of ventilation.

*Flat terrace roof.*—All the other rooms and verandahs in the building, are to have flat roofs, consisting of 4 inches of concrete over two layers of 12" × 12" × 1½" good pukka tiles, set in fine lime mortar, the

upper layer of tiles breaking joints with the lower one. The tiles to rest on deodar wood kurrees and beams, the former 1 foot apart from centre to centre, and the latter 4 to 5 feet from centre to centre. The kurrees over beams laid 4 feet from centre to centre to be 4" × 3", and those for beams 5 feet from centre to centre 5" × 3". The scantlings of the beams to be as follows:—

For rooms 20' span 16" × 10", 4·5 feet from centre to centre

"	18'	"	16" × 10", 5·33	"	"
"	17½'	"	16" × 8", 3·78	"	"
"	15'	"	14" × 7", 4	"	"
"	12'	"	12" × 6", 4	"	"
"	10'	"	10" × 6", 4	"	"

wall plates for beams, 6" × 4", and for kurrees 4" × 3". Calculations of the above scantlings are given in the sheet of calculations annexed.

*Boarded ceilings.*—The court rooms, as well as all the main rooms of the building, are to have boarded ceilings of 1 inch thick boards, nailed on to the beams, and ornamented with mouldings, and brackets of deodar wood, as per section, and neatly varnished.

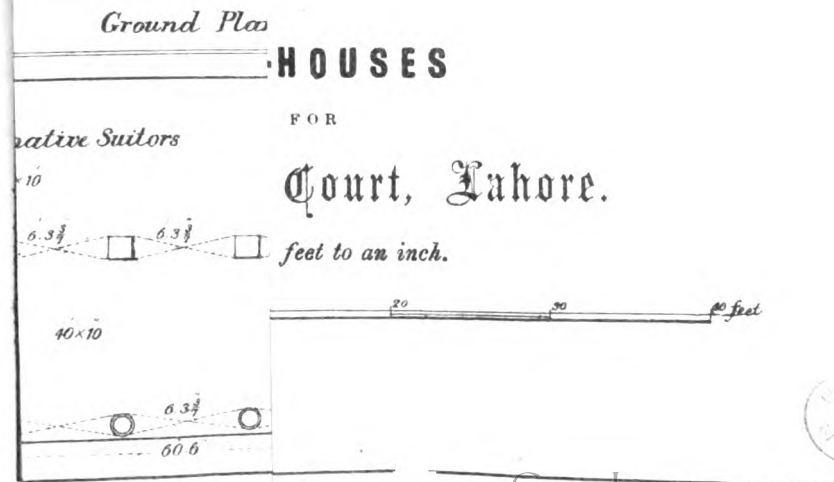
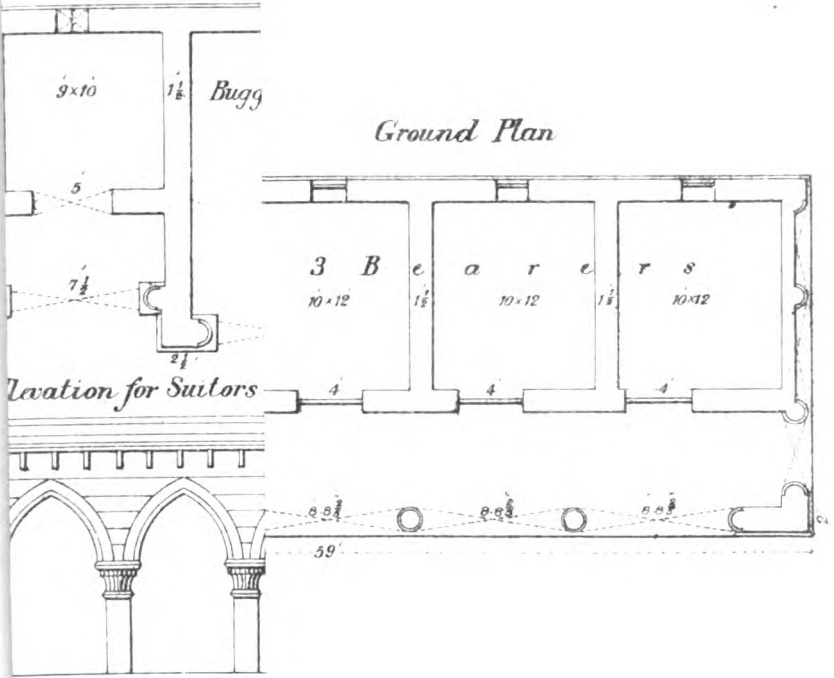
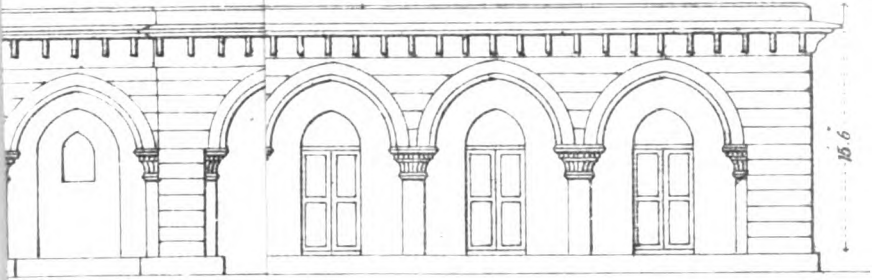
*Pucca plaster and white-washing.*—The superstructure to be pucca plastered and white-washed inside; the mortar for the plaster, consisting of 94 parts of best kunkur lime, mixed with 6 parts of fine stone lime, and the whole well ground in a mill. The plaster to be executed as follows:—The joints of the masonry to be first raked out, and cleaned, and the walls wetted, the mortar to be then laid with force on the walls, so as to fill in the joints fully, without leaving any interstices, and the plaster then floated on in a layer of ½ to 1 inch in thickness, well wetted and beaten, and worked to a proper face, free from all blemishes and blisters; over this, a thin coat of fine lime mortar, made of equal parts of the best kunkur and stone limes, well ground, to be floated, and properly rubbed to an even surface with a wooden trowel; on which, when dry, three coats of fine whitewash, made of pure white lime, to be given.

*Cornices, mouldings and ornamentation.*—All the outer cornices, mouldings and ornamentation, to be carefully executed in brickwork, and all the inner ones, in plaster, finished neatly to the exact shape and dimensions given on the drawings.

*Stonework.*—The motto selected for the building to be carefully and neatly executed in white and black marble, (ground of white marble

98

of Servants houses



**HOUSES**

FOR

**Court, Lahore.**

feet to an inch.



and letters of black marble,) over the main entrances of the building, as shown on the drawings. (*Plates XLIII. and XLIV.*)

*Doors and windows.*—The doors and windows to be of sound and well seasoned deodar wood, 2½ inches thick, hung on English hinges, and provided with English bolts and locks. The shape and dimensions of doors to be as per plan, and the joints of the door frames to be accurately fitted. All the outer doors and windows to be panelled and glazed as shown in plan, and all the inner ones to be panelled.

*Skylights and ventilators.*—Skylights to be provided for light and ventilation in the record rooms of the English and Vernacular offices, and glazed upper lights in the court rooms, and all the other rooms. Ventilators with glazed frames for light, to be provided in the corridor and passage, at places marked on the plan.

*Stair-cases.*—Two pukka masonry stair-cases with neat wooden railings, to be constructed for the purpose of giving access to the upper rooms in front and rear of the hall, and to the 2nd stories of the tower. Access to the 3rd, 4th, and 5th stories of the tower, to be provided by means of wooden steps, as shown in the section of the tower.

*Fixtures.*—Raised *daises* for the Judges, with seats for the Officers of the Court, Jury, and Pleaders, and Witness Box, to be provided in each court room. Prisoners' dock to be constructed in the Criminal Court room, and the whole to be enclosed with ornamental iron railings, as per plan, openings being left at the ends, for ingress and egress.

*Punkhas and boarded balcony.*—Punkhas to be provided for all the main rooms and the two court rooms. A boarded balcony 3½ feet wide on iron brackets and having iron railings in front, to be provided over the Judges' seats in each court room.

*Ironwork.*—The finials of the spire of the tower, the railing in the court rooms, and the ornamental iron at the ridge of the slate roof, and the doors of the main entrance into the building, to be of iron, properly lacquered. The spire of the tower to be furnished with an appropriate vane, and the top of the finials and the vane to be gilt. The tie-rods of the trusses, straps, bands, bolts, nuts, &c., to be all of iron, properly lacquered.

*Painting and varnishing.*—The ceilings, doors, windows, inside of upper lights, and skylights, and the railings of the stair-cases, to be varnished with three coats of best spirit varnish. The outside of the sky-lights, and upper lights, to be painted of a light red color.

*Fire-places.*—Fire-places to be constructed in the rooms as shown on the plan, with flues 12 inches square; and the chimney shafts above the roof, to have openings for egress of smoke, aggregating, in area, to 144 square inches. No portion of the woodwork of roof to be allowed to remain in contact with the wall containing the flue, within 4 feet of that flue, and the inside of the flue to be pukka plastered smooth and even, so as to leave no crevices for the lateral egress of smoke.

*Out-houses.*—The out-houses to be of pukka masonry nearly similar to that of the Chief Court, but not so fine. Roof to be flat terrace on 12" × 12" × 2½" pukka tiles resting on sound kurrees of deodar wood, 5" × 4", laid 1 foot from centre to centre; the room at the end of the shed for suitors, to have its roof supported on two beams 14" × 7" of deodar wood, and kurrees 4" × 3", 1 foot from centre to centre. Floor to be well rammed and leaped, and doors to be battened, of deodar wood.

*Compound wall and gates.*—Compound wall and gate pillars to be of pukka masonry, as per plan, and the gates to be of deodar wood, painted of a light red color.

*Pukka well.*—A pukka well, 10 foot diameter, to be sunk in the compound, as marked on the plan of site, and provided with a Persian wheel for drawing water.

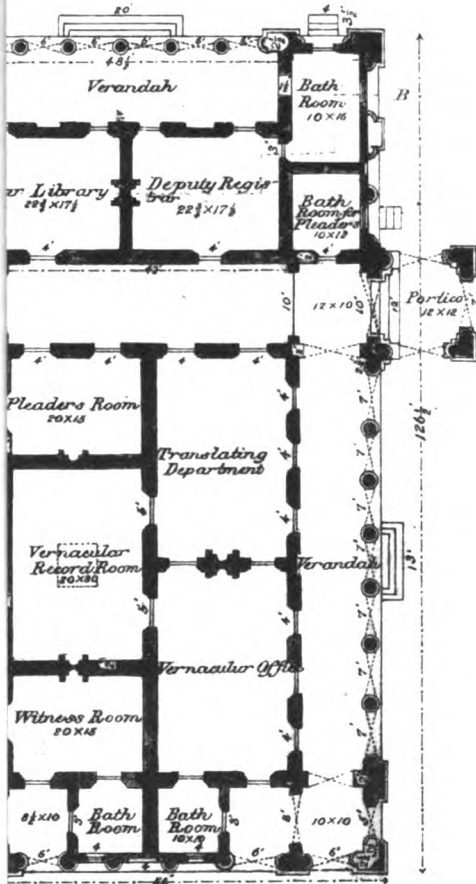
*Laying out the ground and planting trees.*—The roads marked in the compound to be properly laid out, and metalled with good clean kun-kur; trees to be planted on both sides of the roads, and watered from the well.

—————

*Abstract of probable cost of New Chief Court for Lahore.*

	RS.
c. ft.	
1,21,797·21 Excavation of foundations, at Rs. 0-4-0 per 100, ... ..	304
40,599 Concrete work equal to one-third of excavation, at Rs. 10 per 100, ... ..	4,060
68,161 Pukka masonry of foundation, at Rs. 16 per 100, ... ..	10,906
28,290·25 Pukka masonry of plinth, including brick-on-edge under the arch-ways and filling in of earthwork, at Rs. 25 per 100, ... ..	7,073
1,56,347·5 Ditto of superstructure, at Rs. 31 per 100, ... ..	48,468
Centering for the dome, probable cost, ... ..	2,000
r. ft.	
2,247 Outer cornice in brickwork, at Rs. 0-15-0 per foot, ... ..	2,160
s. ft.	
10,158 Outer ornamentation in brickwork above verandah roof, at Rs. 0-8-0 per 100, ... ..	5,079
Carried forward, ... ..	80,050

D.  
10 feet







		Rs.
	Brought forward, ...	80,050
r. ft.	Mouldings of pillars and arches, of outer verandah walls, at Rs. 0-8-0 per 100, ... ..	1,467
502	Ornamental inner cornice of court rooms and hall, (lower floor,) at Rs. 1 per 100, ... ..	502
s. ft.	Pucka plaster, inner, including mouldings, &c., at Rs 5 per 100,	4,230
84,600-25	Whitewashing, at Rs 0-6-0 per 100, ... ..	317
r. ft.	Small cornice of inner rooms, at Rs. 0-4-0 per foot, ... ..	968
s. ft.	Slate roof, 40 feet span, at Rs. 125 per 100, ... ..	9,610
c. ft.	Arched roof and arched floor, at Rs. 39 per 100, ... ..	4,194
s. ft.	Flat roof, at Rs. 70 per 100, ... ..	12,113
24,234-5	Tiled floor, at Rs. 15 per 100, ... ..	3,635
6,636	Doors and windows 2½ in. thick, at Rs. 1-4-0 per foot, ... ..	8,295
13,025	Boarded ceiling, including ornamental wooden brackets, at Rs. 30 per 100, ... ..	3,907
No.	Skylights, at Rs. 80 each, ... ..	800
s. ft.	Ironwork, at Rs. 4 per foot, ... ..	1,216
r. ft.	Iron railings, at Rs. 4 per foot, ... ..	2,624
656	Iron brackets and railings (for balconies in court rooms), probable cost, ... ..	1,000
	Fixtures, including wooden stair-cases, probable cost, ... ..	1,500
s. ft.	Punkhas, at Rs. 0-12-0 per foot, ... ..	1,116
1,488	Stone work, probable cost, ... ..	750
No.	Mantle pieces for fire-places, at Rs. 25 each, ... ..	625
25	Extra woodwork necessary to make the chimneys fire-proof, probable cost, ... ..	1,000
	Finial and vane, partly gilt, probable cost, ... ..	382
	Clock and bell, ,, ... ..	1,000
	Total, ... ..	1,41,247
<i>Out-houses.</i>		
c. ft.	Pucka masonry of foundation, at Rs. 15 per 100, ... ..	930
6,202-5	Excavation of foundation, at Rs. 0-4-0 per 100, ... ..	16
6,202-5	Pucka masonry of superstructure, at Rs. 22 per 100, ... ..	5,606
25,481		5,606
	Carried forward, ... ..	6,525

	Brought forward,	...	...	6,552
r. ft.				
841.5	Pucka cornice in brickwork, at Rs. 0-12-0 per foot,	...	...	631
s. ft.				
5,588	Flat roof on Deodar kurrees, tiles, and terrace, at Rs. 35 per 100,			1,956
372	Battened doors, at Rs. 0-8-0 per foot,	...	...	186
88	Glazed doors, at Rs. 1 per 100,	...	...	88
	Total out-houses,	...	...	4,913
	<i>Compound wall and gates.</i>			
c. ft.				
827	Dressed pucka masonry of gate pillars, at Rs. 33 per 100,	...	...	272
15,000	Excavation of foundation of compound wall, at Rs. 0-4-0 per 100,			38
89,261.25	Plain pucka masonry of compound wall, at Rs. 20 per 100,	...	...	7,852
2,200	Ornamental pucka masonry of 800 r. ft. of compound wall, at Rs. 40 per 100,	...	...	880
s. ft.				
324	Wooden gates, including ironwork, both ornamental and plain, at Rs. 2 per foot,	...	...	648
	Total compound wall and gates,	...	...	9,690
c. ft.				
3,534	Excavation of well, at Rs. 5 per 1000,	...	...	18
1,734	Pucka masonry of well, at Rs. 20 per 100,	...	...	347
1,592	Sinking well, at Rs. 8 per 100,	...	...	127
	Persian wheel for well, probable cost,	...	...	100
	Pillars, pulleys, reservoir, &c., probable cost,	...	...	50
	Total for well,	...	...	642
	Laying out ground and planting trees,	...	...	350
c. ft.				
28,575	Kunkur metalling of approaches, at Rs. 8 per 100,	...	...	2,286
	Total,	...	...	22,381
	Grand Total,	...	...	1,68,628
	Add contingencies, at Rs. 5 per cent.,	...	...	8,181
	Grand Total Rs.,	...	...	1,71,809

K. L.

## No. CXIX.

## WATERWAY OF BRIDGES IN INDIA.

By C. O. BURGE, Esq., A.I.C.E., *Resident Engineer, Madras Railway.*

THE question of the amount of flood discharges seems to have received, at all events in published notes, much less attention than it appears to deserve, and it would be very desirable if comparisons between the conditions of drainage basins and their actual maximum discharges, as far as they can be ascertained, were recorded, more generally than they are, for professional information.

A favorable opportunity having occurred to enable the writer to obtain such information from data that would appear to be singularly well adapted for the purpose, a proportion was sought between the maximum discharges through all bridges\* of and above 80 feet aggregate span, on a section of the Madras Railway 110 miles long, and the terms representing the area and shape of the different basins they drain.

These areas afford a sufficiently wide field for comparison, varying as they do from 2 to 4,400 square miles, and aggregating 10,420 square miles, showing also well marked features. They are drained by bridge openings from the above minimum up to a maximum width of 2,800 feet.

It is obvious at once that when a waterway has to be fixed upon, the result of any rule or formula, is not to be compared to, nor can ever supersede the decision, guided by experience, of a practical Engineer inspecting the site and noting defined flood-marks and the local traditions

\* With two exceptions, omitted as the areas drained are practically indefinable, and the water-courses cannot be traced except for a short distance above bridges.

regarding exceptional freshes. But cases occur in which the experience as well as the other conditions, is limited or altogether absent, and then rules, which can in any case be used as checks, may be useful.

The present enquiry has been to seek a proportion, and not absolute results, so that a constant suitable to the locality, and referring to the circumstances which directly affect the discharge, such as maximum daily rainfall, must be applied to the expression, according to the place in which it is used. It was found then, that the expression, the variation of whose terms adhered, most closely to that of the flood discharge, and which involved only the easily ascertained features of area (A) and length of principal river (L) was

$$\frac{A}{\sqrt[3]{L^3}}$$

All previous rules on the subject that the writer is aware of, regard this discharge to be proportional to some root of the drainage area alone; indices of  $\frac{1}{2}$ ,  $\frac{2}{3}$  and  $\frac{3}{4}$  being variously proposed, but none of these would represent, even by the roughest approximation, the observed progression in the present case; and it is evident that the shape as well as the area of the basin has a most prominent effect on the question. As an exaggerated instance, let a basin be supposed one mile wide and a hundred miles long; it will, with a free outfall, slope the same, and *cæteris paribus*, discharge *per second* a quantity not very dissimilar from that flowing from one of one mile square: though of course the larger area will take much longer to get rid of its flood.

The consideration of the shape, therefore, which is roughly indicated by the ratio of the area to the river length or to some root or power of it, is by no means immaterial to the purpose.

It need hardly be said that this expression  $\frac{A}{L^{\frac{3}{4}}}$  does not vary accurately to a fraction as the recorded discharges, but it is the nearest variation containing the terms A and L only. That it is sufficiently near for all practical purposes will be seen by the following Table, which shows the difference, in the waterways before-mentioned, between the recorded height of flood and that which would satisfy the formula.

Size of each bridge.	Difference between recorded height of maximum flood and that which would satisfy the formula.	
	Formula too low.	Formula too high.
	Feet.	Feet.
Four 20 feet spans, .. .. .	...	2.22
Three 30 feet do., ... .. .	0.80	...
Do. do., ... .. .	...	0.08
Do. do., ... .. .	0.09	...
Do. do., ... .. .	1.81	...
Three 31 feet spans, ... .. .	...	0.54
Four 30 feet do., ... .. .	...	0.10
Five 30 feet do., ... .. .	0.46	...
Do. do., ... .. .	3.40	...
Do. do., ... .. .	...	0.50
Six 30 feet do., ... .. .	...	0.82
Seven 30 feet do., ... .. .	0.03	...
Two 64 feet and two 30 feet spans, ... .. .	0.67	...
Eight 30 feet spans, ... .. .	...	1.82
Five 30 feet do., ... .. .	1.68	...
Four 64 feet do., ... .. .	...	4.64
Do. do., ... .. .	...	0.80
Do. do., ... .. .	1.84	...
Eight 30 feet, one 20, and one 15 feet spans, ... .. .	0.18	...
Four 64 feet and two 30 feet spans, ... .. .	...	0.37
Seven 65 feet spans, ... .. .	...	1.40
Twenty-eight 16 feet 6 inches spans, ... .. .	...	4.12
Eight 59 feet 6 inches do., ... .. .	0.43	...
Nine 54 feet do., ... .. .	0.28	...
Twenty 70 feet do., ... .. .	...	4.63
Twenty four 64 feet do., ... .. .	...	2.21
Twenty 70 feet and twenty 64 feet spans, ... .. .	2.40	...

It will be seen that the greatest difference is such as would be amply included in the extra height which would be in any case provided over the highest flood mark ascertained on the best evidence. In any case no one who knows the difficulty and uncertainty of measuring actual flood discharges in this country would think of leaving anything but an ample margin for contingencies.

The variation  $\frac{A}{L^{\frac{1}{2}}}$  may be approximately accounted for in this way.

The total amount to be passed off evidently varies, other things being the same, directly as the area, and with same area indirectly as the product of various powers or roots of the length of the several channels of drainage (the principal one for simplicity being alone considered in the rule); inasmuch as *firstly*, *ceteris paribus*, the length, considered as length only, extends the time of discharge; *secondly*, as being in itself, the total fall being assumed constant, inversely proportional to the channel slope, the square root of which is a co-efficient in all formulæ for velocity; *thirdly*, as the length of river increases, area being constant, its section diminishes, and, consequently, generally, though not necessarily, its average hydraulic mean depth diminishes also, the square root of which is likewise a co-efficient in discharge formulæ; and, *fourthly*, in same areas greater length of channel usually implies greater sinuosity and consequent greater friction of bends.

It would no doubt be difficult or impossible to allot to their proper sources the different roots or powers of  $\frac{1}{L}$ ; it is enough to say that their product does not differ materially from  $\frac{1}{\sqrt[3]{L^2}}$ , as shown by results over such a wide range as that under notice. It should be added that the falls within a mile of the bridges ranged generally between  $6\frac{1}{2}$  and 17 feet per mile, and in extreme cases as low as  $4\frac{1}{2}$  feet, and as high as 34 feet, showing that the general slopes of the basins, which are probably to some extent indicated by these figures, but which are not considered in the expression, do not appear to affect the question as much as would at first appear likely. The effect is probably counteracted to some degree by the usually greater length of channel in the steeper areas, and its consequences, as above stated; for it is a well known law that all channels seek an equilibrium between their lengths and the tenaciousness of their banks, lengthening themselves and flattening their slopes at bends, by

erosion of their concave shores till this equilibrium is established. If for instance we suppose a drainage basin tilted up at the higher end, the previous equilibrium would be at first disturbed by increased velocity, and the discharge which would be expected to be accelerated, would be to some extent checked by the increased length of channels.

However, it would be interesting to find if the variation holds good with reasonable accuracy in places where, as in the delta and plains, the slopes are generally much under  $6\frac{1}{2}$  feet per mile.

With a maximum rainfall in 12 hours of about 5 inches to 6 inches as far as can be ascertained, and in a country chiefly of primary formation ranging from about 500 to 1,300 feet over sea level, the constant would be 1,300, with

A = Area of basin in square miles,

L = Length of main river in miles,

D = Discharge in cubic feet per second,

and the formula would stand as follows:—

$$D = 1,300 \frac{A}{\sqrt{L^3}}$$

Much confidence should not, however, be placed in this constant, as the rainfall records are not to be depended on; though the daily maximum does not probably vary much over the section. Also it seems to the writer that the ordinary constants in hydraulic formulæ for river discharges give too high results in the case of heavy floods carrying great quantities of sand, &c., in suspension in rivers with steep beds.

This however does not affect the variation proposed.

Great expense, and inconvenience having arisen from both deficiency and excess in provision for waterways in this country, and as the data in this formula, as regards the larger streams, are easily ascertained from existing maps, the above expression is now suggested as an attempt at a solution of the question.

C. O. B.



## No. CXX.

## THE "MILNE" PATTERN OF LEVELLING STAFF.

[ *Vide* Plates XLIX. to LI.]

BY C. C. SULLIVAN, Esq., *Head Master, Thomason C. E. College, Roorkee.*

AMONG the accompanying drawings will be found a representation of a new pattern of Levelling Staff, lately Invented by Mr. Sub-Conductor A. Milne, the Senior Surveying Master of the Madras Civil Engineering College. This pattern has been tried also at the Roorkee College, and compared with other forms already in use. The following extract from the "Roorkee College Manual of Surveying" describing the forms most common hitherto in use, will serve as an introduction to a description of Mr. Milne's pattern :—

" A great many varieties of staves have been invented, but those most generally used in Upper India are Gravatt's telescopic pattern, in three pieces, and a staff 12 feet long, all in one piece. Gravatt's pattern varies in length from 14 to 17 feet; it consists, as already said, of three parts, and when stowed away for carriage they are thrust down into each other. The bottom part is about 4 inches wide, the middle is a little smaller to go into it, and the upper part still smaller; consequently, the divisions and figures are more cramped as the staff becomes lengthened, and therefore more difficult to read at distances. Besides this, the upper part is moved by the slightest wind, and owing to its being so thin, a very slight movement sets it vibrating.

" The staves made in the Roorkee Workshops are all in one piece, 12 feet long and  $2\frac{1}{4} \times 1\frac{1}{4}$  inches scantling, and made of the best seasoned wood. The graduated scale is painted on the broad side, and is protected from

injury by being slightly countersunk, leaving a beading of  $\frac{1}{4}$ -inch at each side. All staves are now graduated into feet and decimals of a foot, and generally read to the second decimal place. The arrangement of the lines marking the ultimate divisions, so that they may be visible as far as possible, has given rise to many different plans; side by side in the accompanying *Plate XLIX.*, are given the systems of division to be found on Gravatt's, the Roorkee, and Conybeare's staves. The great objection to Gravatt's method of reading is, that the centre of any figure is not opposite the real reading, and in the Roorkee pattern, the figures are decidedly too small, being only  $\cdot 08$  foot high. Conybeare's pattern is perhaps the most easily and quickly read, but when a surveyor is in the habit of using one particular pattern, he will of course prefer that with which he is already familiar. In a properly marked staff, the figures showing the feet should be in red and  $\cdot 15$  foot high; the figure showing the tenths of feet should be in black and  $\cdot 10$  foot high; and in the red figures (showing feet) the included circles in the figures 8 and 9 should be filled in with black, so as to distinguish them from the 3 and the 6,—a very necessary precaution, as one is sometimes apt to forget that the glasses of the Dumpy level invert everything. It would be as well to paint the beading at each side of the staff, alternately white and black in foot-lengths; as then, when taking long shots in trial levelling, if the red figures are indistinct, the eye can readily count the alternating white and black feet. In trial levelling, staves divided to such great nicety are not required; those divided simply into feet and tenths are amply sufficient, and are much sooner read, the surveyor again dividing the tenth of the foot merely by his eye."

The following is Mr. Milne's description of his own pattern:—(*Vide Plate LI.*)

"There are two scales placed close to one another, each division of which is  $\frac{1}{30}$  of a foot or  $\cdot 02$  of a foot. The divisions on the left are placed higher than those on the right by  $\cdot 01$  of a foot, thus allowing the staff to be read to  $\cdot 01$  of a foot. The right hand divisions show the even hundredths and the left hand the odd. The top of the red figures indicate the feet and the top and bottom of the black figures the tenths of a foot, the top being even, and the bottom odd.

"The divisions are twice the size of those on the ordinary staff, and can therefore be read at twice the distance of an ordinary one, or with twice the facility at the same distance.

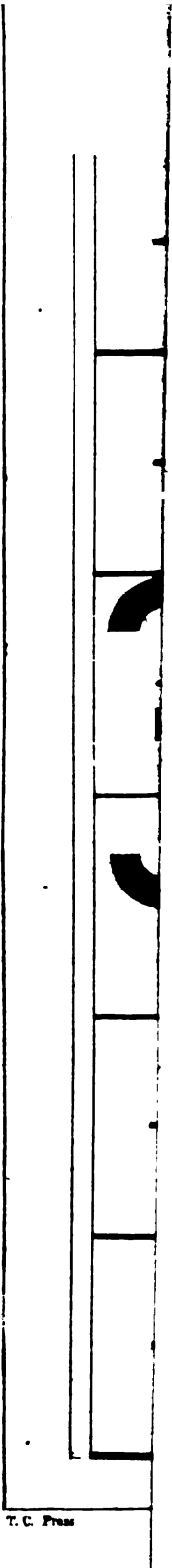
"From the arrangement of the lines the hundredths between the consecutive blank figures are more easily reckoned, and therefore more rapidly read off than on the ordinary staff."

When comparing this pattern with others at recent trials made at Roorkee, it was found that on placing it side by side with the Roorkee Staff, the ends of the right hand and left hand divisions (next the line separating the two scales) partially blended into one straight line, at the same distance as that in which the lines of graduation on the Roorkee Staff became somewhat indistinct. The advantages claimed for this method in regard to increased distinctness at *long* ranges were not therefore fully borne out in the opinion of the experimenters: who in this particular found the Roorkee and Milne patterns to be on a par. There is, however, no doubt (as above stated) that when a person is in the habit of using one particular pattern, he will of course prefer that with which he is already familiar: and it is difficult to obtain an unanimous verdict in comparing different forms of levelling staves.

The publication of the drawing and description of this 'Milne' pattern of Levelling Staff in the pages of the "Professional Papers of Indian Engineering," will serve to introduce this pattern to a large circle of Engineers, and to ventilate the question of the most effective system for adoption in Surveying.

Another pattern which has been much used on Public Works in Rajpootana, and has found many advocates of its practical excellence, is shown in *Fig. 5, Plate LI*. In this the feet are marked from the centre of one figure to the centre of the other, the tenths of feet are denoted by the corners of the large triangles and the hundredths by those of the small ones. The figures being  $\cdot 18$  foot high, can be seen at a greater distance than those in any of the preceding patterns. There being no figures to show the tenths of feet the risk that has to be guarded against of reading the tenths for feet, and *vice versa*, when using the other staves is avoided. This is a great advantage, more especially when owing to the atmosphere or defective sight, red cannot be distinguished from black. This method of graduation is also most useful when taking long shots in trial levelling.

· C. C. S.



T. C. Press

"From the arrangement of the lines the hundredths between the consecutive blank figures are more easily reckoned, and therefore more rapidly read off than on the ordinary staff."

When comparing this pattern with others at recent trials made at Roorkee, it was found that on placing it side by side with the Roorkee Staff, the ends of the right hand and left hand divisions (next the line separating the two scales) partially blended into one straight line, at the same distance as that in which the lines of graduation on the Roorkee Staff became somewhat indistinct. The advantages claimed for this method in regard to increased distinctness at *long* ranges were not therefore fully borne out in the opinion of the experimenters: who in this particular found the Roorkee and Milne patterns to be on a par. There is, however, no doubt (as above stated) that when a person is in the habit of using one particular pattern, he will of course prefer that with which he is already familiar: and it is difficult to obtain an unanimous verdict in comparing different forms of levelling staves.

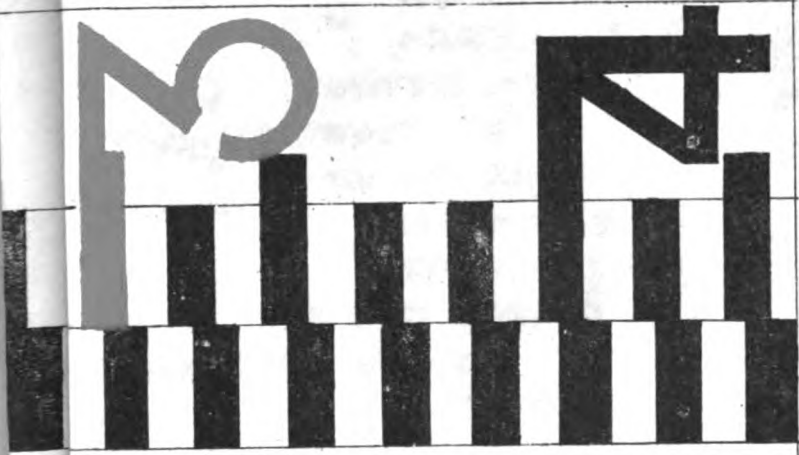
The publication of the drawing and description of this 'Milne' pattern of Levelling Staff in the pages of the "Professional Papers of Indian Engineering," will serve to introduce this pattern to a large circle of Engineers, and to ventilate the question of the most effective system for adoption in Surveying.

Another pattern which has been much used on Public Works in Rajpootana, and has found many advocates of its practical excellence, is shown in *Fig. 5, Plate LI*. In this the feet are marked from the centre of one figure to the centre of the other, the tenths of feet are denoted by the corners of the large triangles and the hundredths by those of the small ones. The figures being  $\cdot 18$  foot high, can be seen at a greater distance than those in any of the preceding patterns. There being no figures to show the tenths of feet the risk that has to be guarded against of reading the tenths for feet, and *vice versa*, when using the other staves is avoided. This is a great advantage, more especially when owing to the atmosphere or defective sight, red cannot be distinguished from black. This method of graduation is also most useful when taking long shots in trial levelling.

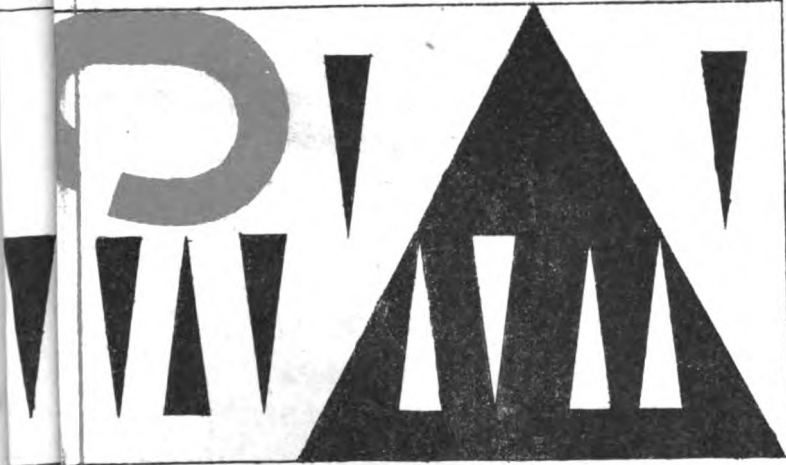
C. C. S.

137124





TR







No. CXXI.

RAFTERS AND PURLINS.

By CAPT. ALLAN CUNNINGHAM, R.E., *Hon. Fell. of King's Coll. Lond.*

[The notation in this paper is that of the 3rd Edition of the Roorkee C. E. Treatise, Vol. I., Sec. V., and of the (new) Thomason C. E. College Manual of Applied Mechanics, No. IIIA., of which Part II. will shortly be issued—both by the present author].

*Preface.*—It is proposed in this Paper to explain how the proper scantlings of Bars under two simultaneous Loads, viz., either—

- (1). Simultaneous Direct and Transverse Load, or
- (2). Two simultaneous Transverse Loads,

may be found, and to give formulæ suited for the practical Engineer without further reference.

*Practical Examples.*—Familiar practical examples of these cases occur—  
of (1)—in the Rafters of a Roof Truss, and in the Tie-Beams and Straining-Beams of both Roof- and Bridge-Trusses; and  
of (2)—in the Purlins of a Pent-Roof.

The Results in this Paper are reduced to the special forms they take for these, as being practical, useful cases. A numerical example is added at the end.

[*Previous treatment.*—The *Theory of Strength of Bars* under case (1) of simultaneous Direct and Transverse Load has been already published in several Text-Books—(in Rankine's Civil Engineering, &c.)—but the results are not reduced to convenient forms. The investigation of (2) Strength of a Bar under two simultaneous Transverse Loads is believed to be new].

2. **Rafters.**—The weight of roofing material and roof-framing, also the weight of absorbed rain, snow, or occasional workmen on the roof constitute the VERTICAL LOAD. The pressure of wind on either side of a Roof constitutes a Load which is perpendicular to the Roof-slope,—i. e., the NORMAL LOAD.

The above Loads being resolved *parallel* and *perpendicular* to the Rafter-slope are equivalent to Load of *two kinds*.

1°. *Direct Load* or *Stress* (T).—This is the sum of ‘resolved parts’ (of the Load of all kinds) along the Rafter.

2°. *Transverse Load*.—This is the sum of ‘resolved parts’ (of the Load of all kinds) perpendicular to the Rafter.

*Small Rafters*.—These are,—in consequence of the Load being distributed over them,—always subject to both kinds of load (1° and 2°).

*Principal Rafters*.—These are loaded only by the Purlins: they are *always* under ‘Direct Load’ (1°) due to their being component parts of the Truss; but the Transverse Load depends on the position of the Purlins, thus

(a). *Purlins placed only over the ‘Supports,’* (*i. e.*, over the Wall-plate, Strut-heads, Ridge).—No Transverse Load on the Rafter-segments.

(b). *Purlins between the ‘supports.’*—Transverse Load on the Rafter-segments due to those Purlins only which are not over the ‘Supports’.

3. **Tie-Beams** and **Straining-Beams**.—The horizontal or slightly sloping “Ties” of a Roof- or Bridge-Truss are—as far as their use *as a part of the Truss* is concerned—simple TIES (*i. e.*, Bars in Tension); and the horizontal “Straining-Bars” (at top) of a Queen-Post Roof-Truss or Trapezoidal Bridge-Truss are—as far as their use *as a part of the Truss* is concerned—simple STRUTS or PILLARS, (*i. e.*, Bars in compression). They are in all cases—as parts of the Truss—under a “Direct Stress” (Tension or Thrust).

It is often convenient, however, to attach a heavy ceiling to the Tie of a Roof-Truss, or to lay a platform or heavy covering on the Tie of a Bridge-Truss, or on the Straining-Bars of a Queen-Post or Trapezoidal Truss. The weight of these (*i. e.*, of the ceiling, platform, &c., including of course Live Load liable to come on them) is a pure TRANSVERSE LOAD on these Bars which may then be called with propriety TIE-BEAM and STRAINING-BEAM.

[Ties and Straining-Bars are of course always under the Transverse Load of their own weight, and to that extent are certainly BEAMS. But as their own weight is usually an inconsiderable portion of their whole Working Load, it seems preferable to restrict the use of the terms TIE-BEAM, STRAINING-BEAM to those cases in which they carry a heavy TRANSVERSE LOAD *in addition to that of their own weight*, and to use the terms, TIE-ROD, STRAINING-BAR for those loaded transversely only by their own weight.]

4. *Principle of Design.*—The following principle seems obvious :—

“ The scantling of a Bar under both Direct and Transverse Load must be suited to resist both *simultaneously*”,.....(1).

[The necessity of this is often overlooked, probably on account of the increased complexity of the problem. When *one* kind of Load greatly preponderates,—as is sometimes the case,—it is fairly admissible to design the scantling for that Load only, as the large factors of safety used, or a slight increase on the so calculated scantling will commonly provide for the omission].

It may be premised that in Engineering practice there are only a few figures of cross-section in ordinary use for Rafters, Tie-Beams and Straining Beams, depending on the nature of the material, viz.,

(a). *In Timber*,—a solid rectangular section.

(b). *In Ironwork*,—a T-section.

Now, it is known that Transverse Load produces both Longitudinal Stress and Transverse Shear. The two sections above are of a type which when strong enough to bear the Longitudinal Stress is known to have *excess of Shearing Strength*. It suffices, therefore, in Engineering practice to express Rule (1) thus :—

“ A Bar, under both Direct and Transverse Load should be able to bear the (algebraic) sum of the two Direct (Longitudinal) Stresses which they produce”,..... (2).

Which condition may be thus formulated :—

Let  $p'$  = Max. Long. Stress-intensity due to the Transverse Load,

$p''$  = Max. Direct Stress-intensity due to the Direct Load,

$f$  = Modulus of strength =  $f_t$  or  $f_c$  (below) } which must *always*

$f_t$  = Modulus of tensile strength,

$f_c$  = Modulus of crushing strength,

be divided by a  
'Factor of safety' =  $s$ ,

$b, d$  = Maximum breadth and depth of cross-section,

Then the sectional area (A) of scantling must be everywhere such that

$$p' + p'' = \text{or} < f \div s, \dots \dots \dots (3).$$

This is the fundamental condition (2) expressed in its simplest symbolic form. To adapt it to calculation of scantling,  $p'$ ,  $p''$  must be expressed in terms of the known quantities (Load, span, &c.) and sought quantities ( $b, d, t$ ).

Premising that in Engineering practice it is convenient to make Rafters, Tie-Beams, and Straining Beams, of *uniform section* throughout their length—or, at any rate, throughout the length of each 'segment' or 'bay' (the piece between two adjacent 'joints'), it follows from the principles

of Transverse Strain that the section of Maximum Bending moment ( $M_m$ ) is also that of Maximum Longitudinal Stress (due to Transverse Load), so that if

$M_m$  = Maximum Bending Moment,

$I$  = Moment of inertia of the section of  $M_m$  about its neutral axis,

$y_t, y_c$  = Distance of neutral axis of the section of  $M_m$  from the outer edge in tension or compression,

then by the well known expression for "Moment of Resistance" to flexure

$$p' = \frac{M_m}{I} \cdot (y_t \text{ or } y_c), \dots\dots\dots (4).$$

Also if  $T$  = 'Direct stress' (viz, 1<sup>o</sup> of Art. 2), to be found as explained\* in any Treatise on Trusses,

$A$  = Cross-sectional area (net section in tension, gross section in compression),

then, on the usual rough assumption that the 'Direct-Stress' ( $T$ ) is approximately uniformly distributed over the area ( $A$ ), and also that, if  $T$  be a Thrust, the 'Pillar' is a 'Short Pillar' (i. e., not liable to bend under the Load  $T$ ),

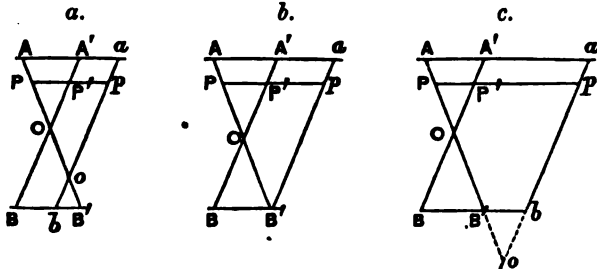
$$p'' = T \div A, \dots\dots\dots (5).$$

Hence Eq. (3) reduces to

$$\frac{M_m}{I} \cdot (y_t \text{ or } y_c) + \frac{T}{A} = \text{or } < \frac{f}{s}, \dots\dots\dots (6).$$

5. *Graphic illustration*—(Fig. 1a, b, c).—The following will throw considerable light on the above process. It is known that under the Transverse Load alone the 'state of strain' and 'state of stress' throughout a cross-section is *uniformly varying*, and may be represented by a pair

Fig. 1.



of triangles as  $AA'OBB'$ , in which  $O$  is the position of the 'neutral axis'

\* See Rankine's Civil Engineering, Art. 114, et seq.; 339, et seq.; 376, et seq.  
 or, Roorkee C. E. Treatise, 3rd Ed., Vol. I., Chapter XXV., } by the present writer.  
 Thomson C. E. College Manual, No. IIIA, Chapter V.

and the width  $PP'$  of the figure represents the strain- and stress-intensity through the layer at  $P$ : and the extreme breadths  $AA'$ ,  $BB'$  represent the maximum longitudinal strain or stress-intensity ( $\pm p'$ ).

On the same scale take  $A'a = P'p = Bb$ , to represent the uniform strain- and stress-intensity ( $p''$ ) due to the 'Direct Load' ( $T$ ).

Then the figure  $AaobB'$  is the graphic representation of the state of strain and stress due to the combined Transverse and Direct Load, representing by its width  $Pp$  at any point  $P$ , the Resultant Strain and Stress due to both Loads.

It is obvious that all the strains and stresses are the Resultants (or algebraic sums) of the separate strains and stresses due to the separate Loads, also that the

$$\text{Maximum stress-intensity } Aa = p' + p'',$$

$$\text{Minimum stress-intensity } bB' = -p' + p'',$$

also that  $o$  is the new position of neutral axis, and that it may fall on  $OB'$ , or on  $B'$ , or on  $OB'$  produced according as  $p'' < = > p'$ , and that in the two latter cases all the Resultant Strains and Stresses are of one kind, *i. e.*, either all Tensions or all Compressions.

[The latter case (Strain and Stress all Compressible) is an important one in the Theory of Stability of tall Masonry Chimneys, Piers, and Pillars, exposed to severe Transverse Strain due to Wind, Current, &c. This case is considered in Paper No. LXXV., of Professional Papers on Indian Engineering, Second Series, "On Transverse Strain in Pillars," by the present author].

*Practical remarks.*—From these figures it can be seen at a glance that in a Bar under combined Transverse and Direct Load the maximum stress-intensity ( $p'' + p'$ ) occurs at one side ( $Aa$ ) of the section and is always much greater than the minimum stress-intensity ( $p'' - p'$ ) which occurs at the side  $B$ . This shows the peculiar propriety of a **T**-section to resist this manner of loading, and that the head of the **T** should always be placed on the side of maximum stress.

6. *Reduction of Eq. (6).*—It will be useful to reduce Equation (6) to the special forms it takes for the ordinary cross-sections ( $\square$  or **T**), and also to exhibit the usual values of  $M_m$  suited to Rafters, Tie- and Straining-Beams, so as to be available without further reference.

*Ex. 1.  $\square$ -Section.*—It is shown in works on Applied Mechanics that in this case,  $I = \frac{1}{12} bd^3$ ,  $y_c = \frac{d}{2} = y_e$ ,  $A = bd$ , so that Eq. (6) becomes

$$\frac{6 M_m}{bd^3} + \frac{T}{bd} = \frac{f}{s}, \dots\dots\dots (7).$$

If now either  $b$ ,  $d$ , or the ratio  $b : d$  be fixed from other considerations—such as that of providing sufficient STIFFNESS, or other practical convenience, then Eq. (7) will give scantling-dimensions strong enough to bear both the Direct and Transverse Load.

The form of the above equation suggests the following simple process, which is preferred by some to the direct use of that equation.

STEP I. Calculate the scantling  $b'$ ,  $d$  of  $\square$ -Section suited to carry the Transverse Load alone, *i. e.*, from the usual equation,

$$M_m = \frac{f}{s} \cdot b d^2, \dots\dots\dots (8).$$

STEP II. Calculate the breadth  $b''$  of a scantling of same depth ( $d$ )—as that just found—suited to carry the Direct Load alone, *i. e.*, from the usual equation (as a 'Short Pillar'),

$$T = \frac{f}{s} \cdot A = \frac{f}{s} \cdot b d, \dots\dots\dots (9).$$

Then from Eq. (8, 9,) it is clear that,

$$\frac{6 M_m}{d^2} + \frac{T}{d} = \frac{f}{s} \cdot (b' + b''), \dots\dots\dots (10),$$

and this becomes identical with the fundamental equation (7) if  $b = b' + b''$ , *i. e.*, if the scantling-breadth be made the sum of those found in Steps I, II.

Ex. 2. T-Section.—With following notation,

- $A_h, A_s =$  areas of head and shank,
- $t_h, t_s =$  thicknesses of head and shank, *both small*,
- $b =$  breadth of head,
- $d_s =$  depth of shank,
- $d' =$  "Effective depth"  $= d_s + \frac{1}{2} t_h$ , *nearly*,
- $y_h =$  distance of neutral axis from foot of shank,

then the *approximate* expressions for  $y_h, I$  (*see* Rankine's Civil Engineering, Art. 163) are

$$y_h = \frac{d'}{2} \cdot \frac{A_s}{A}; I = \frac{d'^2}{12} \cdot \frac{A_s}{A} (A_s + 4A_h), \dots\dots\dots (11).$$

The result of substituting these expressed in terms of  $b, d'$ , &c., into Eq. (4) is rather complex, but if the thicknesses  $t_s, t_h$  of shank and head be taken equal, then Eq. (4) becomes *approximately*, writing  $t_s = t_h = t$ ,

$$\frac{6 M_m}{t d' (d' + 4 b)} + \frac{T}{t (b + d')} = \frac{f}{s}, \dots\dots\dots (12).$$

As there are *three* quantities ( $t, d', b$ ) to be found, and but one equation (12) connecting them, two additional conditions must be added. It

will be generally convenient to assign *provisional* numerical values to  $b$ ,  $d'$  from considerations of practical convenience, or of providing sufficient **STIFFNESS**, so that  $t$  will be the only quantity to be determined, in which case the value of  $t$  is at once *explicitly* given by Eq. (12)—a matter of some importance in calculation.

The form of Eq. (12) suggests the following process analogous to that detailed in Example 1. After assigning, as before, *provisional* values to  $b$ ,  $d'$ —

**STEP I.** Calculate the thickness  $t'$  of **T**-section (with the assigned values of  $b$ ,  $d'$ ) suited to bear the Transverse Load *alone*, i. e., from the usual equation.

$$M_m = \frac{f}{s} \cdot \frac{t'd}{6} (d' + 4b), \text{ approximately, } \dots\dots\dots (13).$$

**STEP II.** Calculate the thickness  $t''$  of **T**-section (with the assigned values of  $b$ ,  $d'$ ) suited to bear the Direct Load (T) alone, i. e., from the usual equation, (as a 'Short Pillar'),

$$T = \frac{f}{s} \cdot A = \frac{f}{s} (b + d') t'', \text{ approximately, } \dots\dots\dots (14).$$

From Eq. 13, 14, it is clear that

$$\frac{6 M_m}{d'(d' + 4b)} + \frac{T}{b + d'} = \frac{f}{s} (t' + t''), \dots\dots\dots (15).$$

and this becomes identical with the fundamental equation (12) if  $t = (t' + t'')$ , i. e., if the scantling thickness ( $t$ ) be made the sum of the thicknesses determined by Steps I. and II.

7. *Thin Rafters and Straining-Beams.*—A little consideration will show that the use of Eq. (5),  $p'' = T \div A$ , which involves the use of Eq. (9) and (14) in Step II. of Art. 6, really involves the assumption—when compression is in question—that the Bars are **SHORT PILLARS\***, not liable to bend under the Direct Stress (T) alone.

But if the scantlings be *small*—as would commonly be the case in ironwork—these Bars should be considered **VERY LONG PILLARS\***, liable to bend under the 'Direct Stress' (T) alone.

The modifications of formulæ (7) and (12) to suit this case would be complex, and the theory of the subject is hardly perfect enough to make it advisable to effect them.

It is considered that it will be sufficient for practical purposes in this case to use the method detailed in Steps I., II., of Ex. 1, 2, modifying, however, Step II., as below to suit the case\* of Very Long Pillars, thus—

\* See Roorkee C. E. Treatise, Vol. I., 3rd Ed., Chap. XXIII.  
or, Thomason College Manual, No. IIIA., Chap. III.



*Ex. 1A. □-Section.*—STEP II. Let the breadth ( $b'$ ) of scantling (of same depth ( $d$ ), as that found in Step I.) suited to the given 'Direct Stress' ( $T$ ), as a Very Long Pillar be calculated, (say) by Gordon's formula

$$T = \frac{f_c}{s} \cdot \frac{b' d}{1 + c \cdot \frac{d^2}{l^2}}, \dots\dots\dots (13),$$

where  $c = \frac{1}{250}$  for good dry timber.

Then  $b = b' + b''$ ,  $d$  are the scantling-dimensions required.

[Observe that the quantity  $d$  of Gordon's formula is defined to be the 'least width', i. e., least width of cross-section measured *only in those directions in which the Pillar is free to bend*. Now the Rafters and Straining-Beams of different Trusses are so stiffened laterally by their connecting purlins or small joists, that they are most liable to bend in the direction of their depth ( $d$ ), which is therefore the ( $d$ ) of Gordon's formula. This consideration gives  $b''$  at once in formula (13), *explicitly* in terms of known quantities].

*Ex. 2A. T-Section.*—STEP II. Calculate the thickness ( $t''$ ) of T-section (with the assigned values of  $b$ ,  $d'$ ) suited to bear the given 'Direct Stress' ( $T$ ) as a Very Long Pillar, (say) by Gordon's formula,

$$T = \frac{f_c}{s} \cdot \frac{(b + d') t''}{1 + c \cdot \frac{d'^2}{l^2}}, \dots\dots\dots (14),$$

where  $c = \frac{1}{3000}$  for wrought-iron.

Then  $b$ ,  $d$ ,  $t = (t' + t'')$  are the scantling dimensions required.

[As in last Example, the depth  $d$  ( $= d'$  approximately) of T-section may be substituted for the symbol  $d$  of Gordon's formula, and  $t''$  is thus given explicitly in terms of known quantities].

8. *Particular values of  $M_m$ .*—It will be useful to exhibit the values of  $M_m$  for certain ordinary cases of Load. One of the two following assumptions is now usually made—

*Assumption.*—Rafters, Tie-Beams and Straining-Beams are—as far as Transverse Load is concerned to be considered BEAMS either—

- 1°. Simple SUPPORTED BEAMS of span equal to distance between adjacent "supports" (measured from centre to centre), or
- 2°. CONTINUOUS BEAMS, i. e., Beams continuous over the "Supports".

The term 'Supports' includes the following :—

- (a). *In small Rafters.*—Ridge-pole and Purlins.
- (b). *In Principal Rafters.*—Ridge-pole, Strut-heads, and Wall-plate.
- (c). *In Tie-Beams.*—Wall-plates, and Feet of all kinds of Braces.
- (d). *In Straining Beams.*—Rafters or Strut-heads.

The latter Assumption (2°) requires investigations of considerable complexity, which have been solved in only a few instances; the results are doubtless somewhat more accurate than those founded on Assumption (1°), but this is not always certain. The first Assumption (1°) leads to results which are believed to be sufficiently approximate for practical Engineering, and so comparatively simple, that it will be adopted throughout this Paper.

*Ex. 1. Small rafters.*—Load approximately uniform.

L = Length of rafter-segment between two purlins *in feet*.

B = Small rafter-spacing *in feet*.

i = Rafter-slope or inclination to horizon.

w = Vertical load-intensity,

w cos i = Transverse portion of ditto,

w' = Normal load-intensity (due to wind),

} *in lbs. per square foot.*

$$\therefore (w \cos i + w') BL = \text{Total Uniform Transverse Load in lbs., ... (15).}$$

$$\therefore M_{\text{max}} = \frac{1}{8} (w \cos i + w') BL^2 \text{ ft. lbs.} = \frac{3}{8} (w \cos i + w') BL^2 \text{ inch-lbs., (16).}$$

*Direct Stress on small rafters.*—This is the same on all equal segments of one rafter; for in consequence of the ‘small rafters’ being securely fastened to the purlins, the ‘Direct Stress’ on each segment is taken up by the purlin at the foot of that segment.

[*N.B.*—The contrary case occurs in Main Rafters in which the ‘Direct Stress’ on the lower segments is always greater than on the upper segments].

wBL = Vertical Load on one segment of small rafter.

w sin i BL = Resolved part of ditto along small rafter.

$$= \text{Direct Stress (T) down small rafter, ..... (17).}$$

*Ex. 2. Principal Rafters.*—The Rafter-segment between adjacent ‘Supports’ (whether Wall-plate, Strut-heads, or Ridge-pole) is considered a SUPPORTED BEAM—of span equal to distance from centre to centre of two adjacent ‘Supports’—loaded at the purlins, (which usually divide each Rafter-segment into the same number of equal spaces,) *i.e.*, is a SUPPORTED BEAM loaded with equal equidistant detached Loads.

[There is usually also a Purlin over each Support, *i. e.*, over the Wall-plate, Strut-heads, and Ridge, but the Loads on such Purlins need not be considered as part of the Transverse Load on each Rafter-segment].

Let L = length of Rafter-segment between adjacent ‘Supports’ *in feet*.

B = Truss-spacing *in feet*.

n = number of equal spaces into which the purlins cut the Rafter-segments.

∴  $L \div n =$  purlin-spacing in feet.

$i =$  Rafter-slope or inclination to horizon.

$w =$  vertical load intensity,

$w \cos i =$  Transverse portion of ditto, } in lbs. per square foot.

$w' =$  normal load-intensity (due to wind), }

$w =$  Transverse (detached) Load on each purlin in pounds.

$$= (w \cos i + w') \frac{BL}{n}, \dots\dots\dots (18).$$

$(n-1) w =$  Total Transverse Load on Rafter-segment.

Hence it may be readily shown\* that

$$M_m = \frac{1}{8} nwL = \frac{1}{8} (w \cos i + w') BL^2 \text{ ft. lbs.}, \left. \begin{array}{l} \\ \\ \end{array} \right\} \text{if } n \text{ be even, (19a).}$$

$$= \frac{3}{8} (w \cos i + w') BL^2 \text{ inch-lbs.},$$

$$= \frac{1}{8} \cdot \frac{n^2 - 1}{n} wL \left. \begin{array}{l} \\ \\ \end{array} \right\} \text{if } n \text{ be odd, (19b)}$$

$$= \frac{1}{8} \cdot \left(1 - \frac{1}{n^2}\right) (w \cos i + w') BL^2 \text{ ft. lbs.}$$

$$= \frac{3}{8} \cdot \left(1 - \frac{1}{n^2}\right) (w \cos i + w') BL^2 \text{ inch-lbs.},$$

[N.B.—It is obvious that in the latter formulæ the factor  $\left(1 - \frac{1}{n^2}\right) = 1$  approximately, its actual values being  $\frac{8}{9}, \frac{15}{16}, \frac{24}{25}, \dots\dots$  &c., when  $n = 3, 4, 5, 6, 7, \dots$  &c].

Ex. 3. Tie-Beams and Straining-Beams.—The Transverse Load on these is usually approximately uniformly distributed, in which case, if

$L =$  Length in feet;  $l =$  length in inches of Beam.

$W =$  Total uniform (Transverse) Load in pounds.

$$M_m = \frac{1}{8} WL \text{ ft. lbs.} = \frac{3}{8} WL \text{ or } \frac{1}{8} Wl \text{ inch-pounds,} \dots\dots\dots (20)$$

9. Purlins.—Introductory.—The consideration of the design of scantling of Purlins is unaccountably generally omitted altogether, even in special Works on Roofs. In Tredgold's Carpentry† the following "Rule" is given:—

"RULE. Multiply the cube of the length of the purlin in feet by the distance they are apart in feet, and the fourth root of the product for fir will give the depth in inches; or multiplied by 1.04 will give the depth for oak, and the depth multiplied by the decimal 0.6 will give the breadth."

This is obviously a most imperfect Rule, for it makes the Purlin-scantling depend solely on the Truss-spacing and Purlin-spacing, and not at all on the weight of roofing material, which is of course an element of quite

\* Thomson College Manual, No. IIIA., Part II., Art. 182, Ex. 14.  
 [N.B.—The Results given for this case in Rankine's Civil Engineering, (several Editions,) Art. 181, Case VIII., are incorrect].  
 † "Elementary Principles of Carpentry," by T. Tredgold, Ed. by J. T. Husst., 1871, See Art. 264.

as much importance as those included. Nevertheless a few lines lower down (*ib.*, Art. 264) it is said

“There is no part of a roof so liable to fail as the purlins.”

The only reason for this can be that so little attention has been paid to their design. The principles of their Design will now be investigated.

10. **Strength of Purlins.**—In consequence of running *horizontally* along the roof-slope, Purlins are subject only to Transverse Load, which Load is however partly *vertical* (due to weight of roofing material, absorbed rain, snow, workmen, &c.), and partly *normal* to roof-slope (due to wind-pressure). They are therefore essentially BEAMS.

[It might be thought sufficient to combine the two Loads (vertical and normal) into a single Resultant Load, and design the Purlin as a BEAM under the Resultant Transverse Load so found. The purlin-cross-section however is for constructive convenience usually placed in such a manner that the direction of that Resultant would be unsymmetrical with respect to it. One necessary step—that of finding the position of the neutral axis—would therefore be one of considerable difficulty, as the usual theory of Bending requires that the Load be applied *evenly across the breadth* of a Beam so as to produce no twisting].

The following method of treatment is considered sufficiently approximate for practical purposes, premising that Purlins are for constructive convenience usually of *uniform cross-section* throughout their length, and further that only two forms of cross-section are in common use, viz.,

1°. *In Timber.*—Solid rectangular section,

2°. *In Ironwork.*—Angle-iron,

and are fastened to the Principal Rafters in such a manner that the breadth (*b*) and depth (*d*) of the cross-sections are *parallel* and *perpendicular* to the Rafter-slope.

Now the actual Loads (vertical and normal) may clearly be resolved into two components *perpendicular* and parallel to the Rafter slope, and these Loads are (if the small rafters be nailed to the purlins) obviously *perpendicular* to and also *evenly distributed over the breadth and depth* of the Purlin-section, so that a Purlin may be viewed as a BEAM in two ways, *i. e.*, under pure Transverse Loads *perpendicular to and evenly distributed*—1° over the breadth (*b*), and 2° over the depth (*d*) of its section.

[*N.B.*—As this is the only manner of Load-application considered in the usual Theory of Transverse Strain, the formulæ of that Theory are of course applicable only to cases when the Load is so applied].

Again, either of two *assumptions* may now be made:—

1°. Each Purlin-segment (*i. e.*, the segment between two adjacent

Trusses) may be treated as a simple SUPPORTED BEAM of clear span equal to the Truss-spacing, or

2°. A Purlin may be considered a CONTINUOUS BEAM.

The first Assumption will (for same reasons as in Art. 8) be adopted throughout this Paper. Further the 'small rafters' (by which the Load rests on the Purlins) are usually so close together that the Purlins are approximately in condition of Beams *uniformly loaded*.

- Let  $B$  = Truss-spacing in feet.
- $B'$  = Purlin-spacing in feet.
- $i$  = Rafter-slope or inclination to horizon.
- $w$  = Vertical load-intensity,
- $w'$  = Normal load-intensity,
- $(w \cos i + w')$  = Transverse load-intensity  $\perp^r$  to rafter,
- $w \sin i$  = Transverse load-intensity  $\parallel$  to rafter,
- $M_m', M_m''$  = Max. Bending Moments due to the Transverse Load  $\perp^r$  to and  $\parallel$  to the rafter.

} in lbs. per sq. ft.

Then by the usual formulæ for Maximum Bending Moment,

$$M_m' = \frac{1}{8} (w \cos i + w') B' B' \text{ ft. lbs.} = \frac{3}{8} (w \cos i + w') B' B' \text{ inch-lbs., (21a)}$$

$$M_m'' = \frac{1}{8} w \sin i B' B' \text{ ft. lbs.} = \frac{3}{8} (w \sin i B' B' \text{ inch-lbs., .....(21b)}$$

11. *Ex. 1. □-Section.*—Consider the nature of (longitudinal) stresses through a solid rectangular cross-section of a Beam under two Transverse Loads, viz.,

$N$  perpendicular to and evenly distributed over the breadth ( $b$ ).

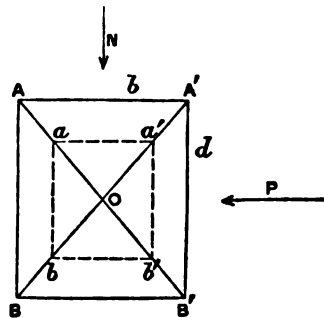
$P$  perpendicular to and evenly distributed over the depth ( $d$ ).

The 'neutral axes' of the Section under either Transverse Load pass through the centre of gravity ( $O$ ) of the Section. It is known also that the (Longitudinal) Resistance to each Transverse Strain is a *uniformly-varying* Resistance, viz.,

1°. Varying for the Load  $N$  with the distance from ( $O$ ) towards  $AA$  or  $BB'$ .

2°. Varying for the Load  $P$  with the distance from  $O$  towards  $AB, A'B'$ , so that in fact

Fig. 2.



1°. AA'OBB' may be considered the 'graphic representation' of (longitudinal) stress due to N.

2°. ABOA'B' may be considered the 'graphic representation' of (longitudinal) stress due to P, the breadths of these figures being at each point the representative of the (longitudinal) stress-intensity at that point.

Hence if the breadths AA' or BB' of the section be suited to resist the (longitudinal) stress-intensity at those parts due to the Load N, then every part of the figure AA'OBB' will be *equally suited* to resist the (longitudinal) stress-intensity thereon due to the Load N. Similarly if the depths AB, A'B' be suited to resist the (longitudinal) stress-intensity at those parts due to the Load P, then every part of the figure A'B'OBA is *equally suited* to resist the (longitudinal) stress-intensity thereon due to the Load P.

It follows also that the material in the figures AA'OBB', ABOB'A' is sufficient to resist the (Longitudinal) Stresses due to the Transverse Loads N, P, respectively, and that therefore *the whole section* contains sufficient material to resist the (Longitudinal) Stresses due to *both* Transverse Loads: also being a solid section it has excess of Shearing Strength.

Let  $\mathfrak{M}'$ ,  $\mathfrak{M}''$  be the Moments of Resistance of the material of figures AA'OBB', ABOB'A' at the section of Max. Bending Moment ( $M_m$ ).

Then by the usual theory of Transverse Strain, it is not difficult\* to show that if  $f_b = \frac{1}{s}$  Modulus† of rupture (by bending) =  $18p_b$ .†

$$\frac{1}{8} \frac{f_b}{s} \cdot ba^2 = \mathfrak{M}' = M_m', \dots \dots \dots (22a).$$

$$\frac{1}{8} \frac{f_b}{s} \cdot bd^2 = \mathfrak{M}'' = M_m'', \dots \dots \dots (22b).$$

Hence, solving these equations, the required scantling-dimensions are

$$b = 2 \sqrt[3]{\frac{1}{f_b \div s} \cdot \frac{M_m'^2}{M_m'}}, \quad d = 2 \sqrt[3]{\frac{1}{f_b \div s} \cdot \frac{M_m''^2}{M_m''}}, \dots \dots \dots (23).$$

It follows also from Eq. (22) and (21) that

$$b : d = M_m'' : M_m' = w \sin i : w \cos i + w' = P : N. \dots \dots (24).$$

or in words,

"The breadth and depth of a rectangular Section should be inversely as the Transverse Loads applied to them.".....(24A).

\* See Thomason College Manual, No. IIIA., (Part II.,) Chap. IX.

† See Rankine's Manual of Civil Engineering, 5th Ed., Table IV.

or, Thomason College Manual, No. IIIA., Tables VI., VII., VII.

Roorkee C. E. Treatise, Vol. I., 3rd Ed., Art 152, and Tables VI., VII.

Again, since in most Roofs,  $i < 45^\circ$ ,  $\cos i$  is generally  $> \sin i$ , so that the rule here laid down will generally give a section in which  $d > b$ .

*Theoretical remarks.*—It is interesting to inquire into the *state of strain* through the section. The above theory provides that along any contour  $aa'b'b$  similar and similarly placed (about O) to the bounding contour AA'B'B of the section there shall be everywhere (longitudinal) STRESS of *equal intensity*, and therefore also (by Hooke's Law—*ut tensio sic vis*) (longitudinal) STRAIN of *equal intensity*, but with the Loads (N, P) as in the figure these STRAINS are

- (a). CONTRACTIONS through  $aa'$  and  $a'b'$  } of equal intensity.  
 (b). EXTENSIONS through  $ab$  and  $bb'$  }

Now, in consequence of the cohesion of the material the simultaneous *equal contractions* and *extensions* due to the separate action of the Loads neutralize each other at every point along the line AOB', which is therefore the "line of no strain" and "of no stress", and is in fact the 'neutral axis' of the section. Moreover the simultaneous contractions along OA' and extensions along OB being *at every point equal* under the separate action of the Loads (N, P) *can take place simultaneously*. It follows that the lines AB', A'B are the "conjugate axes" of the section, also that A'B coincides with the direction of the Resultant of the two Loads (N, P). Thus the theory provides that—

"The Purlin shall be placed with one of the diagonals of its cross-section coincident in direction with the Resultant of the Load".

*Practical remarks.*—The theory here explained gives the ratio ( $b : d$ ) that is most *economical of material*. It is not however *convenient in construction* to have either  $b$  or  $d < 3''$  in Timber, which is therefore to be taken as the *minimum practical value* of both.

Engineering practice has been to make Timber Purlins of *nearly square* section, but there seems to be no sufficient reason (in purlins of scantling larger than  $3'' \times 3''$ ), for not using the above ratio, which has been shown (*cæteris paribus*) to be most economical of material, provided that the resulting ratio  $d : b$  (which will be found usually  $> 1$ ) be not so great as to introduce undue liability to twist, which it must be remembered is not considered in the Theory of Transverse Strain.

In a case in which so large a value results for the ratio ( $d : b$ ) the value of  $b$  so obtained should be considered only as the *minimum required for resistance to pure Transverse Strain*, and should be increased at the

discretion of the designer, so as to provide extra material to resist Twisting.

[To diminish the liability to twisting, it is very advisable that the purlins should be fixed not only to the Rafters, but also be fixed on "purlin-blocks" (of same depth as the purlins) above the Rafters].

12. *Purlin-Deflexion.* ( $\square$ -Section).—It is of course necessary that the scantlings should be STIFF enough to resist undue deflexion that might injure the roofing material.

It is believed that when designed as above, the Purlins will generally be stiff enough whenever—as will generally happen—( $w \cos i + w'$ ) is considerably  $> w \sin i$  which involves the *calculated* value of  $d > b$  in same ratio,—see Eq. (24).

The actual Deflexions parallel and perpendicular to the Rafter slope may easily be calculated, considering as before the Purlin as a Beam under two uniform Transverse Loads, viz.,

$$N = (w \cos i + w') BB', \text{— perpendicular to the Rafter slope.}$$

$$P = w \sin i BB', \text{ parallel " "}$$

$$\text{Thus if } \delta' = \text{Deflexion (in inches), perpendicular " "}$$

$$\delta'' = \text{" " parallel " "}$$

$$E_t = \text{Modulus of (tensile) elasticity.}$$

$$E_d = \text{the 'Roorkee* co-efficient' of (deflexional) elasticity.}$$

Then, see Roorkee C. E. Treatise, Vol. I., 3rd Ed., Art. 614.

$$\delta' = \frac{5}{32} \cdot \frac{(12 B)^3 \cdot N}{E_t \cdot b d^3} ; \quad \delta'' = \frac{5}{32} \cdot \frac{(12 B)^3 \cdot P}{E_t \cdot d b^3}, \dots\dots\dots (25a).$$

$$\delta' = \frac{5}{8} \cdot \frac{B^3 \cdot N}{E_d \cdot b d^3} ; \quad \delta'' = \frac{5}{8} \cdot \frac{B^3 \cdot P}{E_d \cdot d b^3}, \dots\dots\dots (25b).$$

Results (25b) are most convenient for Indian Timber, for which the 'Roorkee  $E_d$ ' is commonly recorded.

12. *Ex. 2.*  $\square$ -Section.—This is the only form of section in common use for iron purlins. There is unfortunately no good Theory extant on either the TRANSVERSE STRENGTH or STIFFNESS of such a section under two simultaneous Transverse Loads.

It is believed that the  $\square$ -section in iron always gives excess of TRANSVERSE STRENGTH whenever it has sufficient TRANSVERSE STIFFNESS, so that the scantling should be designed from considerations of Stiffness.

\* For explanation of this quantity ( $E_d$ ), see any of the following—  
 Paper No. XLIV. of Professional Papers on Indian Engineering, Second Series.  
 Roorkee C. E. Treatise, Vol. I., 3rd Ed., Art. 549, et seq.  
 Roorkee College Manual, No. IIIA., Art. 99, et seq., and Table VIA.



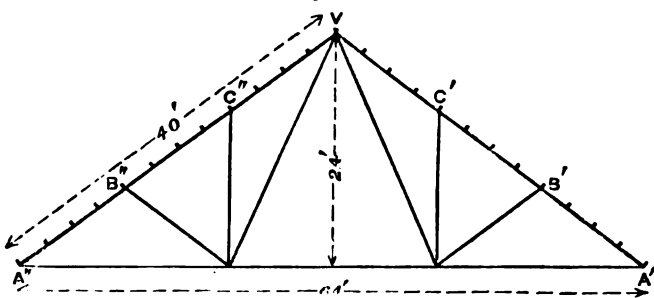
No good set of experiments, nor list of successful examples is, however, accessible for this purpose.

## APPENDIX.

13. The following numerical example is given to illustrate the principles of this Paper, and to show the use of the formulæ:—

*Ex.* The small rafters for the Roof-Truss, figured below, (*Fig. 3*), are spaced at 1 foot apart 'centrally,' and borne on 25 equidistant purlins, viz., 7 purlins at the Ridge (V), 4 Strut-heads (B', B'', C', C'') and 2 Wall-plates (A', A''), and 8 between each of these points (so as to cut each Main Rafter-segment into 4 equal parts). Design the scantlings in Teak for which  $f_c = 12,000$  lbs., taking  $s$  (factor of safety) = 10.

Fig. 3.



*Data for Roof.*—Span = 64', Rise = 24',  $\sin i = \frac{3}{5}$ ,  $\cos i = \frac{4}{5}$ . Rafter-Length = 40', Truss-spacing = 10', Purlin-spacing =  $\frac{1}{8} \times 40' = 5'$ .

Small rafter-spacing = 1'.

Vertical Load of roofing = 40 lbs. per sq. ft.

Allowance for rain 5 lbs. per sq. ft., for purlins, &c., 5 lbs. per sq. ft.

Wind pressure (normal to rafter slope) = 30 lbs. per sq. ft.

*Small Rafters.*— $L = 3\frac{1}{2}'$ ,  $B = 1'$ ,  $w = 45$  lbs.

By Eq. (17),  $T = 45 \times \frac{3}{5} \times 1' \times \frac{1}{2}' = 90$  lbs.

By Eq. (16),  $M_m = \frac{3}{5} \times (45 \times \frac{3}{5} + 30) \times 1' \times 3\frac{1}{2}' \times 3\frac{1}{2}' = 1,100$  inch lbs.

As the scantling will be *small*, it is convenient to make it square ( $b = d$ ); then by Eq. (7).

$$\frac{6 \times 1100}{d^3} + \frac{90}{d^2} = \frac{12,000}{10}, \text{ whence } d^3 - 0.75d = 5.5,$$

from which it is easily found by trial that  $d = 1''.8$ , nearly.

[*N.B.*—It is obvious that in this case the Transverse Load is *by far* the more important portion of the Load.]

*Principals.*— $L = 18\frac{1}{2}'$ ,  $B = 10'$ ,  $n = 4$ ,  $w = 50$  lbs.

It is *convenient in construction* to make the Rafter of *uniform scantling* throughout: now the Transverse Load on each Rafter-segment is the same, whilst the 'Direct Stress' is greatest on the lowest segment. It will therefore suffice to design that segment.

The Direct Stress (T) may be found by any method that is convenient. It will be found\* that if W, W' be the Total Vertical and Normal Loads on one Truss, then

\* See Roorkee C. E. Treatise 3rd Ed., Vol. I., Chapter XXV., Example 8, } where this result is  
or Thomason C. E. College Manual No. IIIA., Chapter V., Example 8, } worked out.

Direct Stress due to the vertical load  $w$  is  $\frac{5}{12} W \operatorname{cosec} i = 27,777\frac{1}{2}$  lbs.

Direct Stress due to the normal load  $w'$  is  $\left(\frac{89}{64} - \frac{1}{6}\right) W' \cot i = 7,083\frac{1}{2}$  lbs.

$$\therefore T = 34,860 \text{ lbs., nearly.}$$

By Eq. (19a)  $M_m = \frac{3}{2} \left(50 \times \frac{4}{5} + 30\right) \times 10' \times \frac{40'}{3} \times \frac{40'}{3} = \frac{1,120,000}{6}$  inch-lbs.

It is easy to see that the scantling will be *large*: indeed in order that the Rafter may be a 'Short Pillar', the scantling depth ( $d$ ) must be not  $< L \div 10$ , i. e., not  $< \frac{3}{4}$  foot = 16 inches.

To design the Rafter as a 'Short Pillar', taking  $d = 16''$ , Eq. (7) gives

$$\frac{1,120,000}{b \times 16 \times 16} + \frac{34,860}{b \times 16} = \frac{12,000}{10},$$

whence

$$b = \frac{4375 + 2178.75}{1200} = \frac{6553.75}{1200} = 5\frac{1}{2}'', \text{ nearly.}$$

As the scantling resulting  $5\frac{1}{2}'' \times 16''$  is inconvenient, it must be recalculated as for a "Very Long Pillar". Assuming  $d = 12''$  as a 'provisional depth', see Art. 7,

By Eq. (8),  $\frac{1,120,000}{6} = \frac{1}{6} \times \frac{12,000}{10} \times b' \times 144$ , whence  $b' = \frac{11,200}{12 \times 144} = 6''.48$

$$\text{By Eq. (13), } 34,860 = \frac{12,000}{10} \cdot \frac{b'' \times 12}{1 + \frac{1}{250} \times \left(\frac{160}{12}\right)^2}$$

$$\text{whence } b'' = \frac{3486}{1440} \left(1 + \frac{32}{45}\right) = 4''.14$$

$$\therefore b = b' + b'' = 6''.48 + 4''.14 = 10''.62.$$

The scantling-dimensions are therefore  $10''\frac{1}{2} \times 12''$ , nearly.

*Practical Remark.*—The scantling required is so large that it is obvious that Timber is not a very suitable material for so great a load.

*Purlins.*— $B = 10'$ ,  $B' = 3'\frac{1}{2}$ ,  $w = 50$  lbs.,  $w' = 30$  lbs.

By Eq. (21a),  $M_m' = \frac{3}{2} \left(50 \times \frac{4}{5} + 30\right) \times \frac{10'}{3} \times 10' \times 10' = 85,000$  inch-lbs.

By Eq. (21b),  $M_m'' = \frac{3}{2} \times 50 \times \frac{3}{5} \times \frac{10'}{3} \times 10' \times 10' = 15,000$  inch-lbs.

Hence by Eq. (23) making  $f_b \div s = 12,000 \div 10 = 1,200$  lbs.

$$b = 2 \sqrt[3]{\frac{15,000 \times 15,000}{1,200 \times 85,000}} = 2 \sqrt[3]{5.357} = 2 \times 1.75 = 3''\frac{1}{2}, \text{ nearly.}$$

$$d = \frac{M_m'}{M_m''} \cdot b = \frac{35}{15} \times 3.5 = 8.2, \text{ nearly.}$$

*Practical Remark.*—The minimum scantling for Transverse Strength being  $3\frac{1}{2}' \times 8''$ , it would be advisable to increase the breadth say to  $5' \times 8''$  to reduce the chance of twisting.

A. C.

No. CXXII.

---

SLEEPER SLIDES IN JOUNSAR FORESTS.

[*Vide* Plates Nos. LII and LIII.]

---

By C. BAGSHAWE, Esq., *Assistant Conservator, Jounsar Forests.*

---

SLIDES AND TRAMWAY AT MUNDHOL. *Report by Assistant Conservator.*

MUNDHOL is situated on the right bank of the River Tonse, a little below the confluence of the Tonse and Pabur rivers, being the most north-westerly portion of the Pergunnah of Jounsar Bawur, and is bounded by the Native States of Jubal and Taroche.

The forest of Mundhol lies on the inner slope of a range of hills in the form of a horse-shoe, from the edge of which a series of spurs and hollows converge to a central point, known as No. 1 Stage, whence the main ravine commences, which conveys the drainage of the Mundhol Basin to the Tonse.

This ravine, called the Chándnigád, is of varying breadth and slope, and forms the sole exit for timber from the Mundhol forest.

In 1869 a call was made on the Tonse forests to supply a portion of the Deodar sleepers required for the Rajpootana (State) Railway, and it was determined to fell a large number of trees in the Mundhol forest.

This felling was distributed as equally as possible over the whole forest; and within a radius of about  $2\frac{1}{2}$  miles from No. 1 Stage.

The trees having been cut into the required lengths, the logs were collected in small depôts, as dictated by the nature of the ground, and then sawn into sleepers.

Out of the total yield of 155,000 sleepers, 120,000 were carried to No. 1 Stage, the remainder being carried to a depôt about a mile lower

down the Chándnigád: both these depôts were connected with the different log depôts by small carrying paths, which were constructed with steep gradients, so as to reduce the distance as much as possible.

The first season's sleepers, 17,000 in number, were carried to No. 1 Stage, and thence down the Chándnigád by a narrow road,  $6\frac{1}{4}$  miles long, to the river on men's backs; but it was only by most strenuous exertions in the cold weather of 1870-71, and the employment of 300 men for six months, that the sleepers reached the river.

Putting aside the question of rates, it became at once apparent that the sleepers as a whole could never be delivered up to time, unless mechanical aid was brought into play: a sufficient number of coolies being simply unprocurable.

It may be well to note here that, in conjunction with the slides, &c., hereafter described, some 1,500 men were steadily employed at Mundhol during the season 1871-72; large works being in progress at the same time at Lambatach and Dártmír, which at least engrossed another 2,000 men.

Therefore, to have carried a lakh and a half of sleepers  $6\frac{1}{4}$  miles on men's backs, in addition to other work, would not have been possible in two years.

During the next few months many schemes and plans were proposed for conveying the sleepers to the river and many experiments tried.

At length a tramway for 4 miles of the distance was proposed by Mr. Greig, (then Deputy Conservator in charge of the division,) and then a shoot to drop them into the river from the terminus of the tramway.

This plan, as will be seen hereafter, was partially carried out.

In the season of 1871, however, the most important part of the scheme was proposed by the late Captain Lillingstone, viz., the employment of a canal slide from No. 1 Stage right down to the river.

This was a modification and extension of timber slides as employed in Europe and America, and for its simplicity and effectiveness cannot be too highly valued.

Captain Lillingstone's proposal was to construct a wooden canal from No. 1 Stage and run it along the bank of the Chándnigád, to introduce water at intervals from the stream by small wooden troughs, and by means of the force of the water and the fall, to slide the sleepers down without further help than launching them at the one end, and taking them out at the other.

The untimely and lamented death of Captain Lillingstone prevented his doing more than prove by experiments that his plan was feasible.

In the cold weather and spring of 1871-72 the following complete series of works was planned and executed, viz. :—

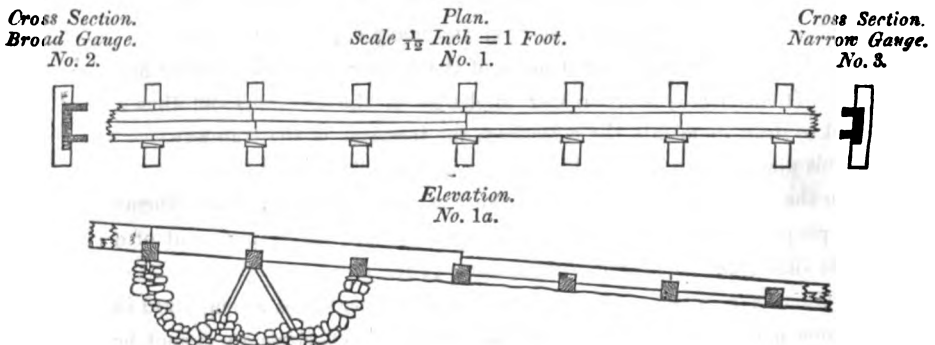
A canal slide was made from No. 1 Stage to the Simla road-crossing (4 miles down the Chándnigád); at this point it being impossible from want of water to carry the slide down the bank of the Chándnigád. A tramway was substituted for  $1\frac{1}{4}$  miles of the remaining distance to the top of a plateau immediately above the River Tonse.

Finally, from the tramway terminus a wooden shoot, 848 feet in length was laid to the river for launching the sleepers.

As noted in the general sketch of the export works, the canal slide was laid down on the banks of the Chándnigád. The rocky and precipitous nature of the country presented great difficulties, and in many places directly the ground was broken up, slips occurred.

The total length of the slide is 21,280 feet, or 4 miles 160 feet; of this 5,224 feet was made of the broad (or 17" gauge), and the remainder, of the narrow (or 12" gauge), *vide Fig. 1.*

*Fig. 1.*



- No. 1. Plan of Slide—shows junction between Broad and Narrow Gauge.  
 No. 1a. Elevation of same.  
 No. 2. Cross section of Broad Gauge—shows Deodar sleepers—double flat for the sides and double block for the bottoms; also the block sleepers supporting the slide :—these block sleepers though shown square, are many of them round, of varying diameters, and of various kinds of timber—the wedges are of Deodar made from waste wood.  
 No. 3. Cross Section of Narrow Gauge—shows slide as made with Chir Scantilings.

The broad gauge was made according to the original plan of Captain Lillingstone, who proposed constructing the main part of the canal slide with the sleepers which were to be floated down it.

In 1871 the gauge of the State Railways had been changed, and in place of 10 feet sleepers, we were called upon to supply 6 feet sleepers.

Captain Lillingstone proposed sawing up 22,400 sleepers in the following shapes, viz. :—

Double flat sleepers, ... ..	6' 6" × 17" × 4½"
Double block sleepers, ... ..	6' 6" × 9" × 8½"

Two double block sleepers formed the bottom of the slide, and the sides were of double flat sleepers standing on edge, *vide Fig. 1*, plan, elevation and cross section of the canal slide, broad gauge. Each of the double sleepers was ultimately to be sawn into two ordinary sleepers and sent down the slide.

The plan of having the slide of 17" gauge was abandoned for the following reasons, viz. :—

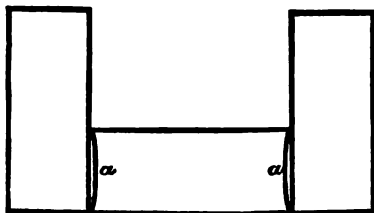
- (a). It was found that the sleepers had too much play in the bottom of the slide, and were damaged in transit.
- (b). That at the curves and dips in the slide they were liable to jump out if the water-supply were at all short.
- (c). That owing to the broad gauge being formed of four pieces, in each 6' 6" length, the leakage was great, as the sleepers flying from side to side loosened all the joints.
- (d). That the sleepers forming the slide also suffered greatly; about 50 per cent. being rendered useless.

The narrow (or 12" gauge) was adopted, and Chir scantlings 13' × 12" × 5" and 6' 6" × 12" × 5" substituted for the Deodar sleepers.

The details on *Fig. 1* show the construction of the narrow gauge and junction with broad gauge.

One point, however, requires notice, viz., the plan adopted for making the slide water-tight.

In preparing the scantlings forming the bottom of the slide, each 5" side was hollowed out about ¼", (*see a, a, Fig. 2.*) then joined up tight with the wedges.



*Fig. 2.*

On the failure of the broad gauge, it was at first proposed to relay the whole length, but time being a great object, the following plan was carried out, viz. :—

In 1,000 feet the gauge was reduced by fixing a 5" scantling to one

side; 2,000 feet was relaid narrow gauge with Chir scantlings, and the remainder left broad gauge.

The sleepers were stopped at the end of the slide by the bed of the slide being widened out into a table 42 feet long by 12 feet at the further end which is raised about 1 foot.

It was at first an open question whether the slide should be carried down to the river, but later on it was found to be impossible, owing to lack of water as the Chándnigád for the last 2 miles is dry for nine months out of the twelve, there being a number of holes down which the water mysteriously disappears.

It may be asked why the water already brought down the slide should not suffice for the remaining  $1\frac{1}{4}$  miles.

The reason is, that at the steeper portions of the slide the sleepers acquire a greater velocity than the water, and throw it out of the slide. And though numerous feeders are introduced, barely sufficient water reaches the end of the slide.

The average time taken by a sleeper travelling down the 4 miles of slide is 20 minutes.

Sleepers are launched at the head of the slide at the rate of 1 per minute, or 700 per diem, but with a large supply of water as many as 1,200 can be launched in one day.

During the season 1872 (an unusually rainy year), the average was 800 per diem.

The results of last year's work show that no more than .72 per cent. of sleepers floated were damaged in transit. And it is very certain that in carrying sleepers by coolie labor, the damage would have been much greater.

A memorandum showing the cost of the slide under the different heads is annexed.

The following heads of expenditure may require some explanation, viz.:—

*Head II.*—Includes all timber used, beams for slides, bridges and block sleepers, the Deodar sleepers alone excepted.

*Head IV.*—Shows the expenses incurred in making dams to collect water and wooden troughs to convey fresh supplies of water to the slide.

*Head VI.*—Represents the cost of squaring the timber and laying down the slide as far as skilled labor is concerned.

*Head IX.*—Gives cost of the share of tools now in Stock in Jounsar, but specially brought for the slide and similar works.

*Head X.*—Includes such miscellaneous items as repairing tools, purchase of iron, medicine, stationery, &c., erecting huts for workmen, carriage of money, and compensation for land taken up or damaged.

*Head XIII.*—Includes repairs of damage done to slide by floods, and putting the slide in thorough repair, after 80,000 sleepers had been floated down in 1872.

To give an insight into the details of cost, I may mention that the rates for labor were as follows, viz. :—

Coolies 5 annas per diem, carpenter 8 annas per diem, masons 6 annas per diem, and that on the above rates piece-work was given out. Sawing was paid for at Rs. 3-2 per 100 superficial feet. Atta was supplied to skilled laborers at 10 seers per rupee, and to coolies at 8 seers per rupee (the latter being the cost price to Government).

The rates paid for floating sleepers down the slide was Rs. 1-14 per 100; this rate included pay of chokidars, who moved up and down the slide to report any hitch.

Five per cent. on the total amount paid for floating sleepers during the season was paid to the contractors.

It will be seen that the actual cost of floating 82,000 sleepers, including contingencies, was Rs. 2,083-6-1, or nearly 5 pie per sleeper for the 4 miles of carriage.

These details are given to enable the table of costs to be checked.

The general financial results will be dwelt on hereafter.

The line of tramway laid down in the Chándnigád commences at the terminus of the canal slide, or Simla road-crossing, and just at the head of a gorge where the ravine widens out into a small valley, the stream running down a narrow channel on one side and the tramway following the plateau above.

*Plate LII.* shows the truck used to convey the sleepers to the head of the shoot.

The rails used on the tramway are of Chir timber, 12'  $\times$  5"  $\times$  4"; the sleepers are of Deodar, the ends of long sleepers cut off in 1871 being utilized: each sleeper is 4' 6"  $\times$  5 $\frac{1}{2}$ "  $\times$  5 $\frac{1}{2}$ ".

A simple and effective method of keying the rails was used, *vide Plate LII.*



The sleepers are laid down 2 feet apart and bored up with ballast, so that a maximum of strength combined with elasticity is attained.

The inner side of the rail was lined with hoop-iron on all the curves and steep inclines; this was fastened on to the rail by means of screws from 1 to 2 feet apart.

This was a great preservation of the rails, and though this precaution was taken at a cost of Rs. 320, it undoubtedly paid, and might have been applied with advantage throughout, as one set of rails would then have sufficed to carry the whole number of sleepers down.

In the construction of the tramway, perfection was in many places made subservient to economy of time and money, and many curves and steep gradients are the result.

The tramway has, however, done its work well, so this is hardly to be regretted.

The ironwork of the trucks were supplied by the Roorkee Workshops; the average cost of each truck at Roorkee was Rs. 100-9-0, carriage to forest Rs. 12-4-1, first cost of making up trucks in forest Rs. 6 each, cost of repairs, 1872, Rs. 7-1-6.

The large figure of the last item is due to all the ironwork (save the wheels and clamping screws) being of such bad quality, as to require entire renewal during the season.

Each truck was worked by three men, the load being 22 sleepers. Three journeys were made by day and two by night; separate gangs being employed for day and night-work.

The average number of trucks worked daily was 12, the rest being generally under repair.

The rates actually paid to the coolies for the transport of sleepers by the tramway was 5 annas per score by day, and 6 annas per score by night.

In addition to this, two small gangs of men were entertained at the two steepest inclines to ease the trucks down. Five per cent. on all work done on the tramway was given to heads of gangs.

Inclusive of all miscellaneous expenses, it will be seen from the return of cost annexed, that working down a sleeper last season cost  $5\frac{3}{4}$  pie per sleeper.

The position and construction generally of the Tonse shoot will be understood from the annexed *Plats LIII*.

EXPLANATION.

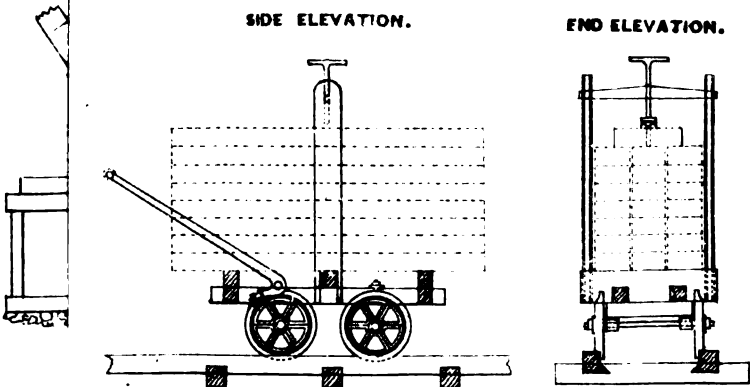
*The thick Black line shows line of Shoot.*  
*The thin do. do. do. original surface of ground.*  
*Length of Shoot 848 feet.*  
*Height of do. 851 feet.*  
*The Trestle No. 2 is built all round with rough rubble.*  
*The Shoot is tied throughout with  $\frac{1}{2}$  bolts at a distance of 4 feet apart, so that, should any of the supports give way, it would still retain its position.*



PLAN OF TRUCK.

SIDE ELEVATION.

END ELEVATION.



Scale,  $\frac{1}{4}$  inch = 1 foot.





There are few remarks to make about this work, the idea is that of the canal slide, adapted to a dry slide.

The shoot was made with the greatest possible exactness, to ensure the sleeper always feeling the bottom of it and not jumping.

The joints are all dove-tailed, and fastened by bolts and nuts; this course was adopted to make the shoot, as it were, one piece, and not a series of disjointed lengths.

Three thousand sleepers per diem can easily be launched from this shoot, and on some occasions that number was largely exceeded.

The number broken, out of 82,000 sleepers launched, was only 16.

The cost of launching per sleeper (*directly*) is *nil*, as launching is included in the Tonse floating charges.

Under that head a saving of 50 per cent. is effected, *i. e.*, if 10 men could launch 1,500 sleepers without the shoot, the same number would now launch 3,000.

Again, the shoot, though only 848 feet long, cuts off fully  $\frac{1}{4}$  mile of carriage; the road from the end of the tramway going down in a series of zig-zags to the river.

I think the success of these works may be deemed apparent when it is noted that 82,000 sleepers were conveyed by them from No. 1 Stage to the river in 1872; and the carriage of the remaining 73,000 insured by the rains of 1873.

The economy of labor and saving in rates of carriage belong to the financial results.

It will be seen from the table annexed, *vide* page 271, that, debiting the whole cost of the works to the 82,000 sleepers brought down the Chánd-nigád in 1872, and likewise the repairs necessary for the season 1873, the gross cost per sleeper is 5 annas and  $\frac{1}{2}$  pie.

The distance the sleepers would have had to be carried on men's backs would have been  $6\frac{1}{4}$  miles.

The actual pay for coolies, had they been obtainable at the ruling rates, would (at a low estimate) have been 5 annas per sleeper, to this amount must be added the 5 per cent. paid to heads of gangs; or on Rs. 25,625 (the cost of carrying 82,000 sleepers) Rs. 1,281-4-0. An establishment to collect labor, check sleeper-carrying, &c., would have been required for six months, say at Rs. 100 per mensem = Rs. 600.

The road required repairs and had to be re-made in parts, say at a cost of Rs. 150 per mile = Rs. 825.

The account then stands thus for 1872 :—

Carrying 82,000 sleepers on men's backs—

	RS.	A.	P.
Coolies, ... ..	25,625	0	0
5 per cent. to tindals, ... ..	1,281	4	0
Establishment, ... ..	600	0	0
Road repairs, ... ..	825	0	0
Total, ... ..	28,331	4	0

or, as conveyed by the slides and tramway, Rs. 25,821-14-3, showing a nett gain on the season's work of Rs. 2,509-5-9.

The services of an additional officer for eight months being omitted from both accounts.

In 1873, 73,000 sleepers will have been brought down by the slides and tramway.

These carried by coolies at the above-mentioned rates would have cost as follows, viz. :—

	RS.	A.	P.
Coolies, ... ..	22,812	8	0
5 per cent. to tindals, ... ..	1,140	9	8
Establishment, ... ..	600	0	0
Road repairs, ... ..	300	0	0
Total, ... ..	24,853	1	8

or as conveyed by the slides and tramway.

Floating charges in canal slide, inclusive of repairs and establishment—

	RS.	A.	P.
73,000 sleepers, at 2 per cent., ... ..	1,460	0	0
„ „ carried by tramway at Rs. 1-12 per cent., ... ..	1,277	8	0
Repairs to shoot, ... ..	100	0	0
Total, ... ..	2,837	8	0

showing a nett gain of Rs. 22,015-9-8, which, added to last year's profit, gives a total of Rs. 24,524-15-5, which sum represents the saving in hard cash by means of the slides and tramway.

The strong point, however, is not the money saving, but the economy of labor in a thinly populated country.

It will have been noted that about 1,500 men were regularly employed at Mundhol in cutting and rolling logs, making roads and paths, sawing sleepers and carrying the same from the small depôts to No. 1 Stage.

In addition, Lambatach, distant 15 miles from Mundhol, constantly

employed another 1,500 men, and Dártmír distant about 30 miles from Mundhol, another 500.

This is taking no account of the men employed at Deobun and Chukrata.

There being this large demand for labor, we can hardly suppose a fresh supply could have arisen without an increase in the rates; and that the results would have been not to introduce much fresh labor into the country, but only to tempt the coolies to run to the most remunerative work, and thus Government would have suffered in several departments, both in work being left incomplete and by paying more for what was done.

It will be seen, therefore, that to value the Mundhol export works at the amount they saved in hard cash at the present rates, is simply not to grasp the whole of their advantages.

*Memorandum of Expenditure on the Canal Slide, Tramway, and Shoot in the Chándnigád, Mundhol Sub-Division, in Season 1871-72.*

Heads of Expenditure.	Name of Work.	Canal Slide.			Tramway.			Tonse Shoot.			Totals.			Grand Total.		
		RS.	A.	P.	RS.	A.	P.	RS.	A.	P.	RS.	A.	P.	RS.	A.	P.
I.	Roadway, .. ..	2,725	12	8	645	6	6	625	7	1	8,996	9	10	..	..	..
II.	Felling, logging, and sawing timber,	4,582	6	9	495	1	0	269	5	0	5,846	12	9	..	..	..
III.	Carriage of timber,	587	7	6	64	6	9	149	15	0	751	18	8	..	..	..
IV.	Dams, sluices, & troughs,	881	7	0	..	..	..	..	..	..	881	7	0	..	..	..
V.	Tramway trucks, ..	..	..	..	2,014	5	11	..	..	..	2,014	5	11	..	..	..
VI.	Carpenter's labor,	3,775	11	5	1,946	3	11	400	13	8	5,222	13	0	..	..	..
VII.	Coolies' labor, with carpenters,	175	11	0	124	1	0	182	5	0	482	1	0	..	..	..
VIII.	Establishment during construction of work,	282	2	10	75	0	0	..	..	..	307	2	10	..	..	..
IX.	Stock, .. ..	334	8	6	285	15	5	52	7	0	672	9	11	..	..	..
X.	Miscellaneous, ..	514	15	10	146	0	4	190	14	0	851	14	2	..	..	..
XI.	Working charges in 1872, ..	1,952	12	8	2,087	15	0	..	..	..	4,040	11	8	..	..	..
XII.	Establishment during working season, 1872, ..	180	9	10	66	8	9	..	..	..	197	2	7	..	..	..
XIII.	Repairs in 1872, ..	719	5	1	307	5	3	29	12	0	1,056	6	9	..	..	..
XIV.	Total cost per work,	16,562	9	8	7,353	6	8	1,900	14	9	..	..	..	25,821	14	8
XV.	Average cost per sleeper in 1872, }	0	8	2	0	1	5½	0	0	4½	0	5	0½	..	..	..

*Remarks by G. GREIG, Esq., Offg. Conservator of Forests, N. W. Provinces.*

19th July, 1873.

The main point to be observed in regard to these Mundhol sleeper works

is the very great difficulty experienced in obtaining labor and the able way that difficulty has been overcome by the Forest Officers, and with such a great saving of expense to Government. In fact, it was more than a difficulty, for it would have been impossible to have collected sufficient labor, at anything like a fair rate of pay, to have enabled us to deliver the number of sleepers required for the Rajpootana (State) Railway from Jounsar, within the specified time, without the aid of contrivances described in the Article under notice.

The canal slide is 4 miles and 160 feet in length. At the foot of this slide (or where the Mussoorie and Simla road crosses the Cháandnigád) the tramway commences, and is carried for  $1\frac{1}{4}$  miles over some steep gradients and abrupt curves to the edge of the high bank of the Tonse river. This bank is 351 feet above the river at the spot where the tramway terminates, and quite a sheer precipice for about one-third of the way down from the top. To obtain the proper slope at the top, a gully was cut out into the plateau at a sufficient distance from the edge of the bank, and a wooden slide or shoot was then laid down, as shown in plan, *Plate LII*. This shoot, from plateau to river, is 848 feet in length. It is an excellent piece of work, and was most ably carried out under the immediate supervision of Captain Atkinson (since transferred to the Punjab), directed by Mr. Bagshawe.

It will be observed from Mr. Bagshawe's report, that the saving to Government from slides, tramways, &c., for the Mundhol sleeper works *versus* carriage on men's backs, is for the year 1872, Rs. 2,509-5-9, and on completion of the works, during the current year, there will be a total saving of Rs. 24,524-15-5.

---

*Note by COL. A. FRASER, C.B., R.E., Secy. to Govt., N. W. Provinces, P. W. Department.*

*8th August, 1873.*

The success of the sleeper slides constructed in the Mundhol Forest, both financially and in working, is complete.

The slide consists of 4 miles of sleeper canal (at which point the water-supply fails), is continued by a tramway  $1\frac{1}{4}$  miles long, and is finished by a shoot of 848 feet, by means of which the sleepers are launched into the Tonse.

The total direct saving in carriage of the 155,000 sleepers from the Mundhol Forest by this sound application of mechanical means in

lieu of manual labor, is fairly calculated at Rs. 24,524, and is of course irrespective of the fact that without such mechanical means, the work could not have been done at all in the limited time available, whilst the increased demand for labor would have added to the rates previously given in this forest.

---

SLIDES AND TRAMWAY AT LAMBATACH. *Report by Asst. Conservator.*

Lambatach forms the end of the range of hills situated between the Tonse and Pabur river, and lies immediately above their confluence.

The forest is one of those leased by Government from the Rajah of Tibri; it lies on the eastern and southern slopes of the Lambatach hill, at an elevation varying from 6,000 to 9,000 feet above the level of the sea.

The northern portions of the forest, known as "Thanwar and Dámítir," grow mainly in a series of steep khuds; the central division, "Charkora," on a series of plateaux sloping towards the Pabur and terminating in a precipitous descent to the same. The southern section of the forest known as "Lahasee and Kimari" grow in steep khuds interspersed with small plateau. The stretch of the forest from "Kimari" to "Thanwar" is about nine miles.

The average distance from the centre of the Deodar zone to the Pabur, the nearest river available for water carriage, is about five miles.

The remarks made on the Mundhol sleeper export works, regarding the labor, difficulty, and the necessity of mechanical aid in transporting the sleepers to the river, apply equally to Lambatach, and it is therefore needless to repeat them.

It was first proposed to convey the sleepers at Lambatach to the river as follows:—

By constructing a line of tramway about  $3\frac{1}{2}$  miles in length below "Charkora and Lahasee" to a ravine which runs in nearly a straight line to the Tonse, close to the junction of that river with the Pabur; this tramway would have run close to the lower edge of the Deodar zone, at a level varying from 8,000 feet above the sea, at its commencement, to 7,500, at its terminus. Down the ravine alluded to above, a wooden slide was to have been made to the Tonse.

Early in 1871, when the first mile only of the proposed tramway had been put in hand, Mr. Greig, Officiating Conservator of Forests, decided to amend the plan as follows viz., only to lay down the tramway below the



"Charkora" section of the forest, and to construct a slide to the Pabur through the precipitous ground previously described as lying between "Charkora" and the river.

The reasons for these alterations were, the difficulties that would have been experienced in constructing and working the tramway, owing to the steep and rocky nature of the ground, and the sharp curve that would have been inevitable; also to the discovery that a shorter route was feasible.

The details of the amended plan were, to make a wooden slide to the Pabur from a point about half a mile below the old tramway level, to carry the sleepers in the "Kimari and Lahasee" section to the head of the slide by manual labor, to collect, by the same means, the Charkora and Dámír sleepers, at the head of, and along the line of the tramway, and then run them along the line to its terminus.

The Thanwar sleepers were separated from the bulk of the sleepers by a long stretch of bad ground and had to be arranged for separately.

The tramway was to be constructed of wooden rails and sleepers, of a two-foot gauge, and to be worked with either two or four-wheeled trucks.

From the end of the tramway the sleepers were to be carried on men's backs to the head of the slide.

The slide proposed by Mr. Greig was a dry slide (*i. e.*, the moving power was the momentum given to the sleeper by the fall in the gradient of the slide, not water-power as at Mundhol), and was to be formed of three kurries, 13' x 12" x 5", wedged in block sleepers (short logs) with a nick cut in them to form a bed for the kurries. A small quantity of water was to be introduced at intervals to remove the danger of fire from the friction between the sleepers and the bed of the slide.

One more point in the general plan requires notice, *viz.*, the reason for not making the tramway and slide a continuous line of work, which would undoubtedly have been the neatest plan. The reason was this, the first mile of tramway was already in hand, when the plan for the export work was changed, and a careful consideration of the question proved that it would cost more in time and money to abandon the old road and construct a new one, than to carry the sleepers past the break on men's backs.

The tramway was laid down along the hill side, the line twisting round small ridges, and again running across small plateaux. As a rule, the cuttings were small and mainly through earth: and the line was nearly level.

*Plate LIII.* clearly explains the construction of the tramway, and nothing

requires notice, except the rough nature of the Lambatach tramway as contrasted with the one at Mundhol. The Lambatach tramway was *made first*, and a rough roadway, combined with cheapness, was the object sought; further, as the line was a level one, there was less wear and tear, so that a less pukka work answered all the calls made on it.

When the tramway was first made, the use of four-wheeled trucks similar to those at Mundhol was proposed, but experiment showed that on a line with so many sharp curves on it, this mode of carriage would be both slow and expensive. The two-wheeled truck (*see Plate LIIII.*) capable of carrying twelve sleepers at a journey, was therefore devised by Mr. Greig as a substitute, and answered admirably throughout.

The length of the tramway is 5,188 feet. During the working season ten trucks were used, each truck made four journeys per diem, twelve sleepers being carried by each truck, which was worked by one man; 92,468 sleepers in all were run along the tramway, the working of which was regularly started in June 1872, and completed in March 1873.

The price paid for running the sleepers along the tramway was at first 4 pie per sleeper, and later on 3 pie per sleeper, 5 per cent. on the total price paid to the coolies being paid to the headmen of the gang employed; this rate is apparently slightly higher,—judging it by the distance the sleepers were carried,—than the Mundhol rate; but the idea is fallacious, as a slight addition or decrease in length of carriage does not affect a rate appreciably, as the difference does not permit a man to load up and unload many more sleepers per diem.

The cost of the tramway, &c., will be treated of under the head financial results.

It will be noted that in the Lambatach slide the joints were broken throughout, and that the method of joining the kurries forming the bottom of the slide is different from that adopted on the Mundhol canal slide, but similar to that used later on in the Mundhol shoot: the reason was the same, viz., in a steep slide to give greater coherence to the component parts of the slide. The length of the slide is 1 mile and 1,052 feet.

When the line for the slide was first selected, it was at once foreseen that two great difficulties had to be overcome; (1), to prevent the sleepers leaving the bed of the slide; (2), to check their velocity while in transit.

The depth of the slide was at first seven inches, and it was thought that the use of brakes placed at intervals would overcome both difficulties. Trial brakes were at first put up, with light one-inch planks hanging down at intervals of 100 feet, but no successful results attained. The distance between the trial brakes was then shortened, and two and three-inch planks used, but still the velocity of the sleepers remained unchecked; finally, brakes were tried 15 feet apart, but still, wonderful to say, the sleepers flew down and about the slide unchecked.

It was then resolved to divide the slide into two sections, cut down the depth to  $5\frac{1}{2}$  inches and cover it throughout by fixing planks to the top, and *Plate LIIL* shows the slide in this state.

The covered-in slide has proved an entire success, although care is required in working it.

The speed of the sleepers can be slightly regulated by the amount of water admitted, the sleepers going slowest when there is least water.

The sleepers reach the half-way station at the rate of about three per minute, or 1,000 per diem, when no hitch occurs.

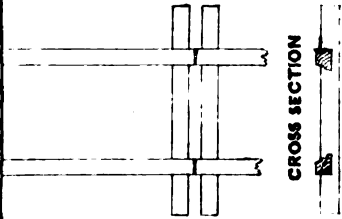
The cost of sending the sleepers down the slide is 12 annas per 100 per stage, i. e., Rs. 1-8 per 100 to the river.

The number of sleepers damaged in transit is from 2 to 3 per cent.; this figure is high, compared with the breakages at Mundhol; but when the nature of the slide is taken into consideration it is not the case. Most of the damaged sleepers can be utilized as half-sleepers or small kurries. So that there will be little loss sustained on them. It is probable too that these breakages are favorable to the Railway Department, as only perfectly sound sleepers stand the ordeal of the slide, any that are cracked or shaken being broken in transit.

The cost of, and returns from, the slide will be shown under the head financial results.

A memorandum is annexed showing the cost of constructing the Lam-batach tramway, and of working down all the sleepers that had to pass over it.

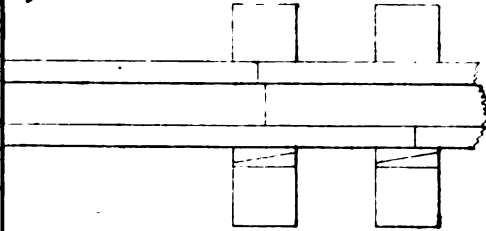
The details of this memorandum requires no explanation, as a memorandum drawn up on similar principles is attached to the report on the Mundhol sleeper export works, and therein fully explained: 92,468 sleepers were conveyed over the tramway at a gross cost of Rs. 3,152-9-0; these sleepers were carried by about 25 men in about seven months.



PLAN

CROSS SECTION

*ing slide uncovered.*



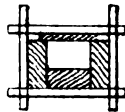
CROSS SECTION



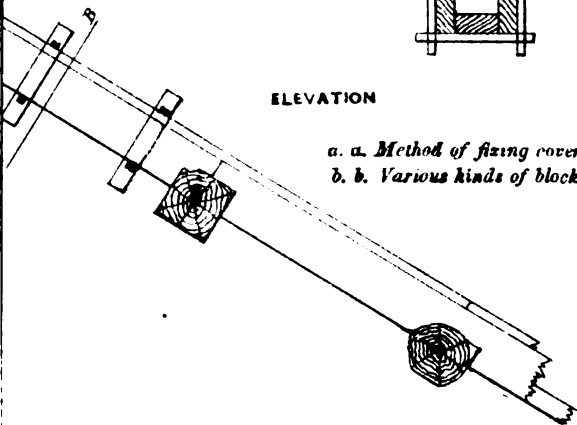
METHOD OF JOINING BOTTOMS.



SECTION ON A.B.



ELEVATION



- a. a. Method of fixing cover.
- b. b. Various kinds of block sleepers.

Scale,  $\frac{1}{2}$  inch = 1 foot.





Had they been carried on men's backs, each man would have taken 8 or 9 sleepers per diem, and the rate at a low estimate would have been 9 pie per sleeper.

The total cost therefore stood thus:—

	RS.	A.	P.
12,468 sleepers by tramway, .. .. .	3,152	9	0
92,468 ,, on men's backs, @ 9 pie per sleeper, plus 5 per cent. to head of gang, .. .. .	4,551	2	6
Net saving, .. .. .	1,398	9	6

A memorandum giving the detailed cost of constructing the slide is given at the end of this report, which it is trusted will give all the information required on this point. The cost of working down the sleepers is also shown under different heads.

Up to the present time 120,082 sleepers have been sent down the slide to the half-way station. Out of this number 42,168 sleepers have been sent on the second stage to the river, and the remainder of the sleepers, 7,914, are going down daily. I may note here that for convenience of reference, the cost of sending the remainder of the sleepers down the slide has been included in the table of cost (*see* heads XIV. and XV.)

As regards the utilization of the slide for the whole forest, the following figures may be useful:—158,224 sleepers were altogether sawn up in Lambatach, of these 38,142 sleepers were in Thanwar, the most northern part of the forest; these sleepers were collected in a depôt on the top of the final descent to the river, and thence carried on men's backs down to the river, at 2 annas and 6 pie each. The remainder of the sleepers, 120,082, went, or are going, down the slide.

It will be seen that the gross cost of taking the sleepers down the slide was Rs. 10,928-8-2; had they been carried on men's backs they would not have cost less than the Thanwar sleepers, viz., 2 annas 6 pie each, and, with other miscellaneous expenses, the account would have stood somewhat thus:—

	RS.	A.	P.
Cost of carrying 120,082 sleepers, @ 2 annas 6 pie each, .. .. .	13,762	18	0
5 per cent. to head of gang, .. .. .	938	2	0
Cost of road to river, .. .. .	500	0	0
Cost of collecting coolies, say, .. .. .	500	0	0
Total cost of carriage on men's backs, .. .. .	20,700	15	0
Total cost by slide, .. .. .	10,928	8	2
Net saving Rs., .. .. .	9,772	6	10

The subject of the saving of labor by tramway and slides being thoroughly recognised, it is needless to dwell on it here, and all that remains to be said is that, as shown in the details previously given, there is an actual money saving:—

	RS.	A.	P.
I. On the tramway, .. .. .	1,398	9	6
II. On the slide, .. .. .	9,772	6	10
Total on the export works, ..	11,171	0	4

It will be noticed that the savings at Lambatach are much smaller than at Mundhol; but this is explained by the fact that the Mundhol export works carried the sleepers about  $5\frac{1}{2}$  miles, whereas at Lambatach the export works were only about  $2\frac{1}{2}$  miles in length, the saving therefore is in nearly the same proportion; and had Thanwar not been so far from the centre of the forest, and had the sleepers from thence come along the tramway and slide, the saving would have been enhanced by one-fourth.

*Memorandum of Expenditure on the Slide Tramway in the Lambatach Sub-Division.*

Heads.	Name of work.	Slide.			Tramway.			Grand Total.		
		RS.	A.	P.	RS.	A.	P.	RS.	A.	P.
I.	Roadway, .. .. .	901	14	10	451	13	2	1,353	12	0
II.	Cutting felling, and sawing timber, .. .. .	2,556	4	6	464	7	0	3,020	11	6
III.	Carriage of timber, .. .. .	896	6	9	13	15	6	910	6	3
IV.	Dams Puluatohs, .. .. .	340	14	0	..	..	..	340	14	0
V.	Tramway Trucks, .. .. .	..	..	..	869	11	6	869	11	6
VI.	Carpenters' labor, .. .. .	2,153	4	4	378	0	0	2,531	4	3
VII.	Coolies' labor with carpenter, .. .. .	891	6	0	66	15	3	958	5	3
VIII.	Establishment during construction of works, .. .. .	331	14	8	53	0	0	384	14	8
IX.	Stock, .. .. .	129	11	0	15	7	0	145	2	0
X.	Miscellaneous, .. .. .	270	0	8	23	2	0	293	2	8
XI.	Working Charges, .. .. .	1,261	15	0	769	13	7	2,031	12	7
XII.	Establishment during working season, .. .. .	202	0	0	..	..	..	202	0	0
XIII.	Repairs, .. .. .	243	1	6	46	4	0	289	5	6
XIV.	Working establishment during remainder of works, .. .. .	108	0	0	..	..	..	108	0	0
XV.	Working charges during remainder of works, .. .. .	641	11	0	..	..	..	641	11	0
XVI.	Total per work, .. .. .	10,928	8	2	3,152	9	0	14,081	1	2
XVII.	Average cost per sleeper, .. .. .	1 anna 5- $\frac{1}{8}$ pies = 1.455 annas.			6- $\frac{1}{8}$ pies = .545 annas.			2 annas.		

*Note by Offg. Conservator of Forests, N. W. Provinces.*

Mr. Bagshawe mentions that the rate the sleepers go down the slide is about three per minute; but I saw them coming down much faster than that when at Lambatach a few weeks ago; they might be sent down at the rate of ten per minute quite easily.

At the bottom of the slide a pool has been formed by damming up a breach of the Pabur river; this pool is about five feet deep at the spot the sleepers come into it, and a very simple arrangement brings all the sleepers handy to the bank. It is as follows:—The waste water is all taken down a small channel about  $2\frac{1}{2}$  feet wide, formed just on the edge of the water-course on the opposite side to the shoal. All the stream from the pool runs through this channel and carries the sleepers with it. A few yards down, some boulder stones are placed, which stop them at a certain point, and they are then lifted out and stacked on dry land ready to hand over to the floating contractor. Mr. Bagshawe has forgotten to mention this.

In conclusion, I would beg to impress on any one making a timber slide the advisability of *very careful* construction; it should be made as accurate and smooth as possible; this will cost a little extra at first, but will be fully recouped afterwards in the saving of repairs and breakages. We commenced by making our slides rather rough, but soon found out the mistake. I doubt if any better means of getting timber from our steep hill sides to the river could be devised than these wooden trough slides; they are adapted to any slope, the steeper it is the less water required, and *vice versa*, and if properly constructed, the timber is not damaged in the least.

Tramways are suitable only in certain situations. I am not much in favor of them. The preparation and laying down of the rails, and the cost of the trucks, is considerable, and I think that a rough wooden road, and something in the style of railway porters' trucks, would answer the purpose equally well, and be far cheaper and simpler. If I am ever called on to work another Deodar forest, I should try this plan instead of tramways.



No. CXXIII.

SCANTLINGS AND COST OF FLAT ROOFING.

[*Vide* Plates LIV., LV.]

BY (*the late*) E. L. ASHER, Esq., *Es. Engr., D. P. W., Goordaspoor.*

8th October, 1878.

*Calculations of Dimensions, Quantities and Cost for Standard Systems of Flat Roofing.*

The general formula for transverse strain is

$$P = s \cdot W = sp_b \cdot \frac{bd^3}{L}, \text{ (P and W being central).}^*$$

The best proportion is  $b = \cdot 63 d$ .

For deodar we take  $p_b = 500$ , and use a factor of safety  $s = 10$ , from which result the following working formulæ,  $b = \cdot 63 d$ .

$$\text{For W distributed, } d^3 = \frac{WL}{64}, \dots\dots\dots (1).$$

$$\text{For W central, } d^3 = \frac{WL}{32}, \dots\dots\dots (2).$$

Flat roofing is taken at 100 lbs. per superficial foot, and if we call the distance apart of the beams, centre to centre,  $\beta$  (feet), we get the following working formula, in terms, simply, of this breadth and of the span—

$$d = 1\cdot16 \sqrt[3]{\beta L^2}, \dots\dots\dots (3).$$

On this formula are calculated at foot of Table I., scantlings of rafters 1 foot apart, for spans of 6 to 16 feet, and scantlings of beams from 4 to 8 feet apart, centre to centre, carrying roof covering on rafters 1 foot apart.

\* *Vide* "Roofing Treatise of Civil Engineering," 1st Vol., (3rd Edition,) p. 596:

It is necessary to fix some minimum practical limit to scantlings, and this is taken at  $2\frac{1}{2}'' \times 4''$ , and this is found to correspond with a span, for rafters 1 foot apart, of 6.4 feet.

In a combination of beams and rafters proportioned on these formulae, there will necessarily be certain spacings of the beams which will give a minimum amount of material in the roof. This minimum is, in all practical cases, given by values of  $\beta$ , which are less than the above limit. Consequently, it need not be ascertained, and we may lay it down that the most economical distance for the beam is  $6\frac{1}{2}$  feet.

The following are results of tabular calculation for roofing of 100 lbs. per superficial foot:—

Up to 11 feet spans, the most economical arrangement (under the rates adopted) is rafters alone—beyond which, up to other limits, the rafters should be carried on beams spaced as nearly as possible at  $6\frac{1}{2}$  feet.

Table I. gives at foot the cost per 100 superficial feet internal of single rafter roofing for spans of 6 to 10 feet. It includes  $6'' \times 4''$  wall plates, and gives the rafter 6 inches bearing on the wall. It is calculated from the following formula, in which  $r$  represents the rate in rupees per cubic foot of the material, wrought and fixed, taken at 1.5, being for short timber. [These tables do not include cost of roof covering].

$$r \left[ \underbrace{\cdot 583 (L + 1)}_{\text{Rafter cub. ft.}} \sqrt[3]{L} + \underbrace{\frac{33.3}{L}}_{\text{Wall-plate cub. ft.}} \right] \dots\dots\dots (4).$$

Half per cent. to be added to cover difference of working scantling.

In a roof combined of beams and rafters, it is impossible to strike a rate per 100 superficial feet in general terms, for various reasons, as the following:—

Conditions of substructure do not admit of equidistant spacing of beams in all cases.

The rate for the end bays differing from the rate for the intermediate bays, the mean rate for the whole will vary with the length of the room.

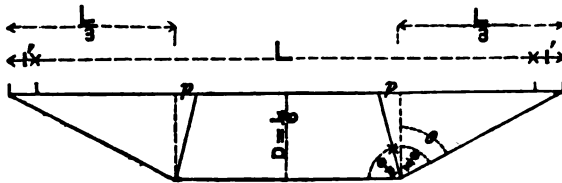
Tables I. therefore gives figures which represent the rate per 100 superficial feet internal, respectively, for a full bay, and for an end bay, of various spans and breadths, of the following items:—

	<i>Whole bay (cost).</i>	<i>End bay (cost).</i>
High-rated woodwork in beam, .. .. }	$r' [ \cdot 00583 L(L+2) \sqrt[3]{\beta^2 L} ]$	$\frac{\text{whole bay.}}{2}$
Low-rated woodwork, in rafters and wall-plates. (End bay includes an end wall-plate, and 3 inches extra length of rafter). }		$r [ \cdot 00583 \beta (\beta + \frac{1}{4}) (L-1) \sqrt[3]{\beta} + \cdot 33 \beta ]$ } $\left. \begin{array}{l} \text{For } \beta = 6 \text{ and under, the rafter is fixed at 10 square inches, and the expression becomes} \\ \text{becomes} \end{array} \right\} \begin{array}{l} \text{Whole bay} \\ + \cdot 165 L r. \end{array}$
Rafters are spiked, with a 3 inch lap. Spans are taken between centres of beams. }	$r [ \cdot 0695 (\beta + \frac{1}{4}) (L - 1) + \cdot 33 \beta ]$ .	
Ironwork in spikes 850 to the maund (5 inch spikes). Rate of ironwork per maund = I. }	$\frac{I(L-1)}{850}$	$\frac{3}{2} \times \text{whole bay.}$

The rates per 100 sup. ft. are struck by multiplying these results by  $\frac{100}{\beta L}$ .

Beyond the limit of, say 20 feet span, it will be economical to substitute trussed beams for the square deodar beams, and the best form is probably the inverted queen-truss. The limit of span for which it will be employed will be fixed by the length of the largest timber conveniently procurable, which we may take at 27 feet. Larger spans than this are unusual, and would require lattice or plate girders. They are not here considered.

Fig. 1.



It is proposed to adopt uniformly a queen-truss of the following geometrical construction:—

Let  $L$  = clear span of the room.

Let it be diminished to  $(L - 1)$  by projecting cornices, and let the length of the beam be 3 feet more than this, to allow  $1\frac{1}{2}$  feet bearing on each side, making extreme length of beam  $(L + 2)$ , which will be taken into calculation as span. The line  $L$  is taken at  $\frac{1}{3}$  the depth of the top

beam, from its upper surface. The depth  $D$  is made  $\frac{L}{6}$ . The feet of the struts are set out at horizontal distance  $\frac{L}{8}$  from ends of beam, and the struts are drawn to bisect the angle of the tie-rod. By this arrangement, the length  $L$  of beam between the walls will (for all practical purposes) be divided into three equal sections of  $\frac{L}{3}$  —

$$\text{for } \tan \theta = \frac{L}{8} \div \frac{L}{6} = 2; \text{ therefore } \theta = 63^\circ 26'.$$

$$\phi = 90^\circ + \theta = 153^\circ 26'.$$

$$\frac{\phi}{2} = 76^\circ 43'; \quad \frac{\phi}{2} - \theta = 13^\circ 17'.$$

$$(\text{see Fig. 2}). \quad p = \frac{L}{6} \tan \left( \frac{\phi}{2} - \theta \right) = \frac{L}{6} \tan 13^\circ 17' = \cdot 04 L.$$

Taking  $L$  to range from 20 to 30,  $p$  will range from 0.8 to 1.2, or the centre lengths will range

$$\text{From } \frac{L}{8} + 2 - 1.6 = \frac{L}{8} + 0.4.$$

$$\text{To } \frac{L}{8} + 2 - 2.4 = \frac{L}{8} - 0.4.$$

The side lengths being, respectively,

$$\text{In the first case } \frac{L}{8} - 1 + \cdot 8 = \frac{L}{8} - 0.2.$$

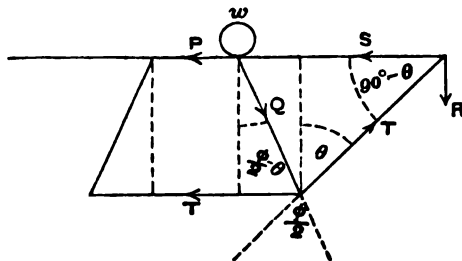
$$\text{In the second case } \frac{L}{8} - 1 + 1.2 = \frac{L}{8} + 0.2,$$

representing a difference in load of  $0.2 \times 100 \beta$ , or 120 lbs. if  $\beta = 6$ .

We may thus consider each strut head as taking a weight  $w = \frac{L}{8} \times \beta \times 100$ ,

$$\text{or } w = 33.3 \beta L.$$

Fig. 2.



This is passed along the beam and along the strut so that

$$P = \frac{w \sin \left( \frac{\phi}{2} - \theta \right)}{\sin \left( 90^\circ + \frac{\phi}{2} - \theta \right)} = 33.3 \beta L \cdot \tan 13^\circ 17' = 7.86 \beta L$$

$$Q = w \frac{\sin 90^\circ}{\sin \left( 90^\circ + \frac{\phi}{2} - \theta \right)} = \frac{33.3 \beta L}{\cos 13^\circ 17'} = 1.027 \times 33.3 \beta L = 34.19 \beta L.$$

Q produces equal tensions, T in the tie-bars such that

$$T = \frac{Q}{2 \cos \frac{\phi}{2}} = \frac{34.19 \beta L}{2 \cos 76^\circ 43'} = \frac{34.19}{.4596} \beta L = 74.39 \beta L.$$

T produces a vertical pressure R, on the wall, and a compression S, such that

$$R = T \frac{\sin 90^\circ - \theta}{\sin 90^\circ} = T \cos \theta = 74.39 \times .447 \beta L \\ = 33.3 \beta L \text{ or one-third of the load.}$$

$$S = T \frac{\sin \theta}{\sin 90^\circ} = T \sin \theta = 74.39 \times .8944 \beta L = 66.51 \beta L$$

Central Compression in beam will be  $P + S =$

$$= (7.86 + 66.51) \beta L = 74.37 \beta L = T.$$

But the segments of the beam are exposed to transverse strain as well as to compression, and it will be found that this consideration will give the greater scantling. This will be given by

$$d = 0.558 \sqrt[3]{\beta L^2}.$$

To recapitulate, we have, for a room of clear breadth L on plan, and trusses  $\beta$  from centre to centre—

Trusses of length L + 2 constructed as per geometrical diagram, Table II.

Tensile strain in tie,  
Compressile strain in beam, } = 74.37  $\beta L$ ,

Compression in struts = 34.19  $\beta L$ ,

Scantling of beam.  $d = 0.558 \sqrt[3]{\beta L^2}$ ,  $b = .63 d$ .

Least scantling of struts in square inches .04  $\beta L$ .\*

Section of tie-rod, square ins. (at 4 tons per square inch) = .0083  $\beta L$ ,  
or weight per lineal foot in lbs. = .0277  $\beta L$ .

Length of tie-rod is taken at L + 5.

The following will be an estimate, in general terms, of the cost of a trussed beam roof per full bay and end bay, from which is calculated

\* The struts are taken at 6" x 6" for all cases, and length is estimated at 5 feet.

Table II., after multiplication by  $\frac{100}{\beta L}$  to reduce to 100 superficial feet.

	<i>Whole bay.</i>	<i>End bay.</i>
High rate deodar wood-work in beam, .. }	$r' [ \cdot 001362 L (L + 2) \sqrt[3]{\beta^2 L} ]$	$\frac{1}{2}$ (whole bay).
Low rated deodar wood-work in rafters and wall plates, .. }	$r [ \cdot 00588 \beta (\beta + \frac{1}{2}) (L-1) \sqrt[3]{\beta} + \cdot 32 \beta ]$	$\frac{1}{2}$ { whole bay + .165 L r.
Same as for ordinary beams, (which see), .. }		
Add for boasting pieces,	$\frac{r L}{4}$	
Ironwork in spikes, same as for ordinary beams, (which see), .. }	$\frac{I (L - 1)}{850}$	$\frac{1}{2}$ (whole bay).
Iron tie-rod, with an addition of 15 per cent. to cover necessary increase to suit sizes, .. }	$\cdot 0004 I \beta L (L + 5)$	$\frac{1}{2}$ (whole bay).
I = rate per maund, .. }		
<i>Additional constant items.</i>		
Hard wood struts and cushions. Rate per cubic foot = r'', .. }	$3 \cdot 5 r''$	$\frac{1}{2}$ (whole bay).
Average ironwork in washers, bolts, and nuts, and strut stirrups, .. }	$\frac{I}{2}$	$\frac{1}{2}$ (whole bay).

Rate per 100 sup. ft. is struck by multiplying these quantities by  $\frac{100}{\beta L}$ .

Table II. is calculated from these formulæ, for rates as follows :—

Long deodar, per cubic foot, ...	Rs. 2 0 0 =	r'.
Short " " " ...	" 1 8 0 =	r.
Kekar wood " " " ...	" 0 12 0 =	r''.
Ironwork, per maund, ...	" 16 0 0 =	I.

*Supplementary Note.*

*February 27th, 1874.*

Table No. IV. gives very full details for the construction of the "Improved Standard Beam," which subsequent experience of the round iron obtainable in the Punjab market, has led me to consider should supersede the working drawing of the original Goordaspore standard plan (*Plate LIV.*), at any rate in this part of the country.

I append a Note and Sketch, which may be useful, on the failure under test of two beams built with round iron of inferior quality. As this variety of iron is particularly untrustworthy in this market, I was led for this as well as for other reasons, to work with approved flat bar iron only, and in working out the design I went into a most careful consideration of every detail so as to ensure the greatest strength, and I have thrown those details into a form such that there should be no necessity for any calculation or modification whatever. I have given strictly tabulated patterns for the tie ends, and their joints, for the range of spans, and a convenient table giving a choice of different dimensions to suit the tabular scantlings, whereby a source of great delay and trouble, and frequent mistakes, is removed.

I have now built a considerable number of beams on this pattern up to spans of 26 feet, and tested them with double loads of 200 lbs. to the square foot, the iron being strained to something like 9 tons to the square inch, and there has been no sign of any weakness or defect.

The original tables remain perfectly correct, except that I find that I use a little more ironwork in the fitting of the trusses, and this may slightly increase Item C of the Trussed Roofing Rate Table.

---

*Note on the fracture, under proof, of two queen-trussed roofing beams, of the Goordaspoor Standard pattern (original). (Plate LIV).*

The beams had a clear span of 19 feet, and were designed to carry each a breadth of 6 feet of roofing, weighing 100 lbs. per superficial foot.

This would, according to the standard calculations of the beams, give a tensile strain in each tie-rod of

$$74.37 \times 6 \times 19 = 8,478 \text{ lbs.},$$

and allowing iron to be strained at 4 tons per square inch, would require a tie-rod weighing per lineal foot

$$.0277 \times 6 \times 19 = 3.158 \text{ lbs.}$$

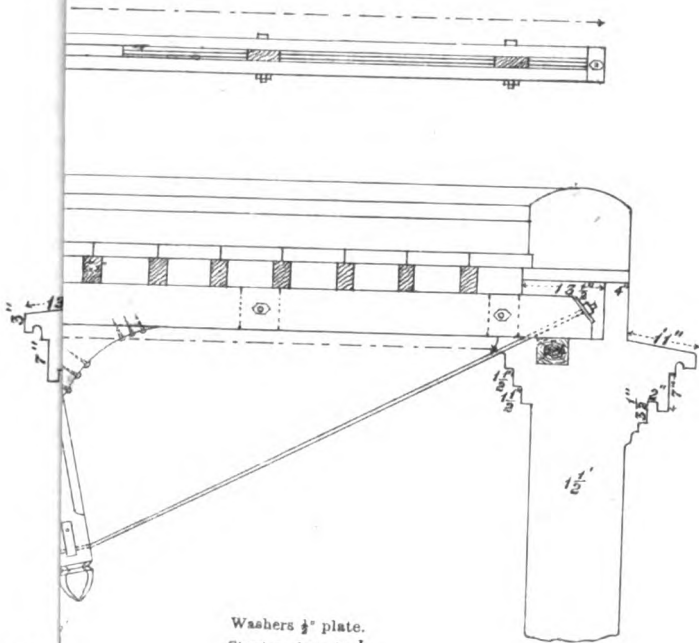
which would have required  $1\frac{1}{8}$ " round iron.

By a smith's mistake, the iron actually used was  $\frac{7}{8}$ " round (say 2 lbs. to the lineal foot) and upset at the ends to 1", so as to allow a clear  $\frac{7}{8}$ " screw.

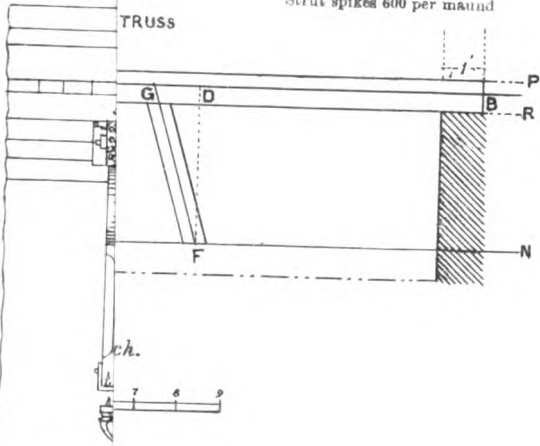
The beams were loaded with six courses of 432 bricks, averaging  $13\frac{1}{2}$  lbs., distributed load on each beam =  $\frac{432}{2} \times 6 \times 13.5 = 17,496$  lbs.

A seventh course was being laid, when the tie-rods of both beams snapped, each at one of the end nuts: both beams broke across and fell in

Beam.

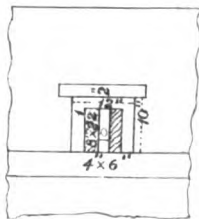


SECTION



Washers  $\frac{1}{2}$ " plate.  
 Strut sockets  $\frac{1}{4}$ " do.  
 Cushion bolts  $\frac{1}{2}$ " round.  
 Strut spikes 600 per maund

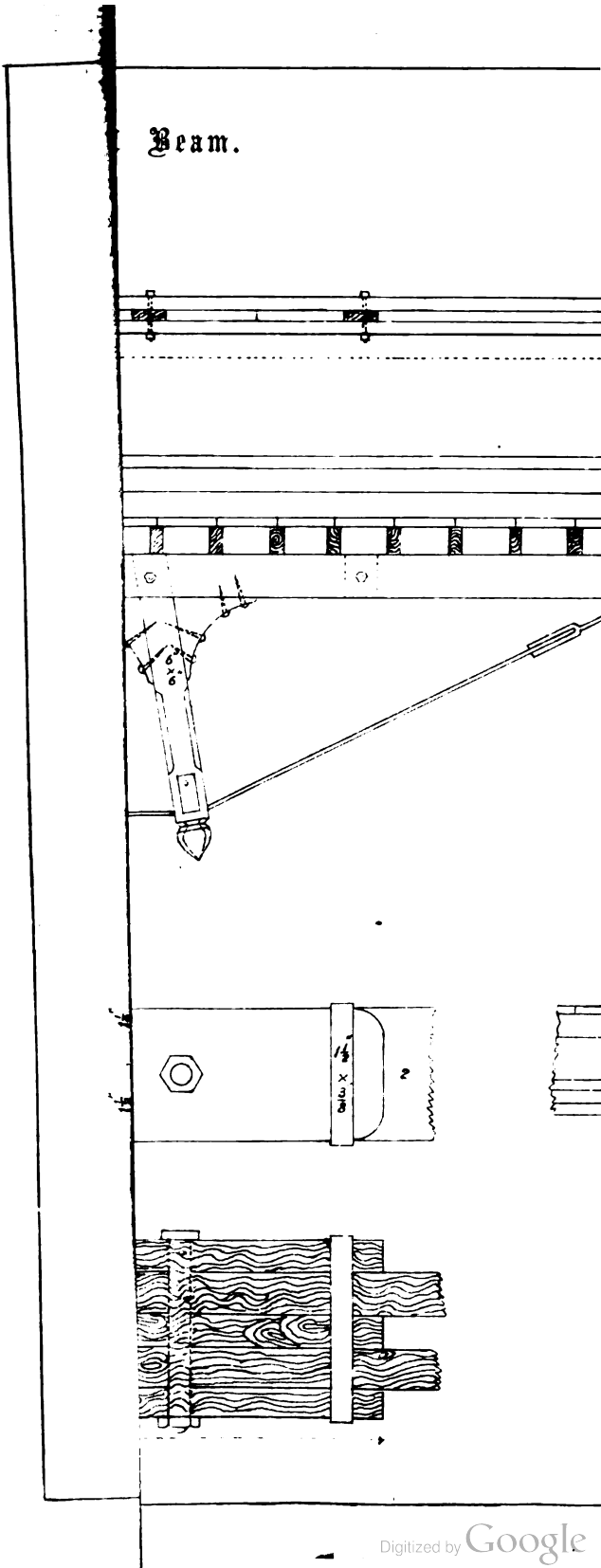
SECTION A. B.







Beam.





with a smash, the superstructure subsiding quite evenly across, and a further smash occurred in the tie-bar of the second beam, owing apparently to a wrench received at striking the edge of the excavation. The beams were fractured at the centre, and all other parts remained intact.

The broken irons showed a coarse, bright, highly crystalline fracture, measuring  $\frac{7}{8}$ -inch clear diameter.

The actual distributed load being 17,496 lbs., was equivalent to a loading per superficial foot of

$$\frac{17496}{19 \times 6} = 153 \text{ lbs.}$$

And the strain on the iron would be obtained by the proportion

$$100 : 153 = 8478 : x$$

$$x = \frac{8478 \times 153}{100} = 12,971 \text{ lbs.}$$

This was on a section  $\frac{7}{8}$ -inch diameter, or

$$0.6013 \text{ square inches.}$$

And the strain per square inch was, consequently,

$$\frac{12971}{.6013} = 21,571 \text{ lbs.} = 9.6 \text{ tons,}$$

or about half the proper parting strain of the iron.

These circumstances point to the necessity for special precautions in the material and construction of these beams. The round iron in the ordinary Indian market is nearly all crystalline and brittle, and both it and the square iron are ill adapted to the sharp angles under which they are here strained. Flat bar iron, on the other hand, is readily obtained of fairly approved quality, and takes a more distributed and less shearing sort of strain at the feet of the struts, and this form alone should be sought. It is in the Umritsur market for Rs. 10-0-0 per maund. The screw head should be of a graduated size and pattern, as given in the supplementary table herewith furnished.

---

*Note of the testing of a pair of beams of improved pattern (Plate LV.), with flat bar ties and standard details.*

Two beams, 19 feet span, designed for 6 foot breadths of bay, or distributed load, each of  $19 \times 6 \times 100 = 11,400$  lbs., were placed 3 feet apart, centre to centre, with an oversailing platform, which was loaded to 6 foot

breadth and 4 feet height, with 3,600 bricks,  $18'' \times 6'' \times 3''$ , averaging 14 lbs. weight, or total weight on the pair  $3,600 \times 14 = 50,400$  lbs., or  $11\frac{1}{2}$  tons distributed per beam. This load, of  $2\frac{1}{2}$  times the permanent load, was applied for 12 hours.

The beams had scantlings very closely as per Tables, viz.,

Wood, 2 pieces each  $7\frac{1}{4}'' \times 2\frac{3}{8}''$ .

Iron at weakest section,  $2'' \times \frac{1}{2}''$ , being  $\frac{1}{8}''$  over tabular section.

The calculated strains per square inch would stand thus—

$$\begin{aligned} \text{Compression in wood} &= \text{tension in rod} = \cdot 7437 W \\ &= \cdot 7437 \times 25200 = 18,749 \text{ lbs.}, \\ &\text{or } 548 \text{ lbs. per square inch.} \end{aligned}$$

Tension in iron = 18,749 lbs., or  $8\frac{1}{4}$  tons per square inch.

Initial camber of the beams was  $\frac{1}{4}$  to  $\frac{3}{4}''$ , and they settled level under the full load, and on its removal recovered all but  $\frac{1}{8}''$ .

E. L. A.

*Note on above Paper by CAPT. ALLAN CUNNINGHAM, R.E. Hon'y. Fellow of King's Coll. London.*

The mode (adopted in this Paper) of calculating scantling of the "Beam" in the proposed "Standard Queen-Truss" is (in my opinion) quite indefensible. It is shown that the mid-segment of the Beam has to bear two distinct Stresses.

1°. "Direct Stress" due to "Equivalent Load ( $w = 33\cdot 3 \beta L$ ) at the joints" of amount =  $74\cdot 37 \beta L$  lbs.

2°. "Direct Stress" due to that Load being actually applied all over it and *producing flexure*.

It is clearly necessary that the scantling should be sufficient to bear both 1° and 2°, but the two scantlings requisite for the partial Stresses 1° and 2° having been (provisionally) calculated, the greater of the two (which happens to be the latter) has been adopted in the Text as the proper scantling. It is clear therefore that the scantling so calculated are *only fitted to bear the Load 2°*.

Perhaps the most convenient\* mode of calculating the scantling requisite to bear both 1° and 2°, is

i. To calculate the scantling ( $b, d$ ) necessary for 2°, which is (as in the Text)

$$d = \cdot 558 \sqrt[3]{\beta L^3}, b = \cdot 63d.$$

ii. Adopting that depth ( $d$ ) to calculate the *additional breadth*, (say  $b'$ ) of scantling to bear 1°. Thus if  $f_c$  = modulus of crushing of the material, and  $s$  = factor of safety,

$$\begin{aligned} \frac{f_c}{s} \cdot b'd &= 74\cdot 37 \beta L \\ \text{whence } b' &= \frac{74\cdot 37 s}{f_c} \cdot \frac{\beta L}{d} \end{aligned}$$

\* See Paper No. CXXI, page 245, of 'Professional Papers on Indian Engineering', Second Series, "on Rafter and Purlins" by the writer of this Note.

Cost per 100 superficial feet  
1 foot apart, centre to centre  
[If boasting pieces are in]

Cost per 100 superficial feet  
span L, and axial distance (breadth)

- A. High priced woodwork in
- B. Low priced woodwork in  
tity by  $\frac{1}{2}r$ ].
- C. Iron-work in *spiking* rafters

Rafters lapped 3 inches and beamed  
on walls. Wall-plates 6" x 4".

BREADTH.	SPAN.	11	12	13
4	A	21.33	23.65	26.02
	B	15.20	14.91	14.66
	C	0.53	0.54	0.54
Total,		37.06	39.10	41.22
5	A	19.80	21.96	24.17
	B	14.96	14.68	14.42
	C	0.43	0.43	0.43
Total,		35.19	37.07	39.02
6	A	18.64	20.66	22.74
	B	14.80	14.52	14.26
	C	0.36	0.36	0.36
Total,		33.80	35.54	37.36
7	A	17.70	19.63	21.60
	B	16.02	15.75	15.49
	C	0.31	0.31	0.31
Total,		34.03	35.69	37.40
8	A	16.55	18.78	20.66
	B	18.15	17.89	17.65
	C	0.27	0.27	0.27
Total,		37.53	36.94	38.58

$$\begin{aligned}
 A &= r' \left[ .1362 (L + 2) \sqrt[3]{\frac{L}{\beta}} \right]. \\
 B &\begin{cases} \text{Below } \beta = 6 = \frac{r}{L} \left[ 6.944 (L - 1) \frac{\beta + \frac{1}{2}}{\beta} \right] \\ \text{Above } \beta = 6 = \frac{r}{L} \left[ .583 (L - 1) (\beta + 1) \right] \end{cases} \\
 C &= .04 I (L + 5) + \frac{I (L - 1)}{8.5 \beta L} \text{ (this includes an allow for difference in working scantlings taken at } L + 5). \\
 D &= \frac{100}{\beta L} \left( 3.5 r' + \frac{I}{2} \right)
 \end{aligned}$$

\* Below 6 1

N.B.—The r

SCANTLINGS.	SPAN.				
	BREADTH.	18	19	20	21
4	$6\frac{1}{2} \times 4$	$6\frac{1}{2} \times 4$	$6\frac{1}{2} \times 4$	$6\frac{1}{2} \times 4\frac{1}{2}$	$7 \times 4$
	1.994	2.105	2.216	2.327	2.438
5	$6\frac{1}{2} \times 4\frac{1}{2}$	$7 \times 4\frac{1}{2}$	$7 \times 4\frac{1}{2}$	$7\frac{1}{2} \times 4\frac{1}{2}$	$7\frac{1}{2} \times 4$
	2.493	2.632	2.770	2.909	3.047
6	$7 \times 4\frac{1}{2}$	$7\frac{1}{2} \times 4\frac{1}{2}$	$7\frac{1}{2} \times 4\frac{1}{2}$	$7\frac{1}{2} \times 5$	$8 \times 5$
	2.992	3.158	3.324	3.490	3.656
7	$7\frac{1}{2} \times 4\frac{1}{2}$	$7\frac{1}{2} \times 5$	$8 \times 5$	$8\frac{1}{2} \times 5\frac{1}{2}$	$8\frac{1}{2} \times 5$
	3.490	3.684	3.878	4.072	4.266
8	$7\frac{1}{2} \times 5$	$8 \times 5\frac{1}{2}$	$8\frac{1}{2} \times 5\frac{1}{2}$	$8\frac{1}{2} \times 5\frac{1}{2}$	$8\frac{1}{2} \times 5$
	3.989	4.210	4.432	4.654	4.876

For scantlings of rafters,

CONSTRUCTION OF TABLE OF COST.

$$\sqrt{33\cdot3}$$

$$\sqrt{\beta + 33\cdot3}$$

extra 15 per cent. to  
(length of tie-rod is

- A = half value for full bar.
- B = value for full bay +  $\frac{16\cdot5r}{\beta}$
- C } half value for full bay.
- D }

Roof rafters are taken uniformly at 10 square inches section:  
most economical spacing, under these rates, is about 7 feet.

	23	24	25	26	27
$7\frac{1}{2} \times 4\frac{1}{2}$	$7\frac{1}{2} \times 4\frac{1}{2}$	$7\frac{1}{2} \times 4\frac{1}{2}$	$7\frac{1}{2} \times 5$	$8 \times 5$	
2.548	2.659	2.770	2.881	2.992	
$7\frac{1}{2} \times 5$	$8 \times 5$	$8\frac{1}{2} \times 5\frac{1}{2}$	$8\frac{1}{2} \times 5\frac{1}{2}$	$8\frac{1}{2} \times 5\frac{1}{2}$	
3.186	3.324	3.462	3.601	3.740	
$8\frac{1}{2} \times 5\frac{1}{2}$	$8\frac{1}{2} \times 5\frac{1}{2}$	$8\frac{1}{2} \times 5\frac{1}{2}$	$9 \times 5\frac{1}{2}$	$9\frac{1}{2} \times 5\frac{1}{2}$	
3.823	3.989	4.155	4.321	4.487	
$8\frac{1}{2} \times 5\frac{1}{2}$	$9 \times 5\frac{1}{2}$	$9\frac{1}{2} \times 5\frac{1}{2}$	$9\frac{1}{2} \times 6$	$9\frac{1}{2} \times 6$	
4.460	4.654	4.848	5.041	5.235	
$9 \times 5\frac{1}{2}$	$9\frac{1}{2} \times 6$	$9\frac{1}{2} \times 6$	$9\frac{1}{2} \times 6\frac{1}{2}$	$10 \times 6\frac{1}{2}$	
5.097	5.318	5.540	5.762	5.983	

see foot of Table I.

The Table shows for different spans and bearing breadths between centres—(1), The depth (first) and aggregate breadth (second) of the truss top or beam. (2), The calculated weight in lbs. per lineal foot of the tie-rod, the nearest working scantling to which will be obtained from Tables in Engineering Pocket Books [say Molesworth, Round and Square Iron, p. 18, Flat bar, p. 27].

The Table is constructed from the following expressions:—

Scantling of beam carrying  $\frac{L}{3} \times \beta$  of 100 lbs. roofing,  $d = 0.558 \sqrt[3]{\beta L^2}$ ,  $b = .63d$ , being in excess of section for compression in lbs. of  $74.37 \beta L$ .

Weight of 1 lin. foot of tie-rod =  $0.277 \beta L$ , corresponding to  $.0083 \beta L$  square inches section strained at 4 tons per square inch, and including 15 per cent. extra to allow for working scantlings. For further information as to the construction of these Tables, reference should be made to the text.

oot].

Cost per 100 superficial feet coverses, from 18 to 27 feet span, and from 4 to 8 feet apart between centres, carryinclud Roof covering.

[If boasting pieces are introducedfull bays, and  $\frac{6.25r}{\beta}$  for end bays].

FULL BAY      END BAY.

Cost per 100 superficial feet of space bfeet of space between the axes of a truss of span of span L and distance  $\beta$ .

- A. High priced woodwork in *truss* of other rate, multiply tabular quantity by  $\frac{1}{3}$ ].
- B. Low priced woodwork in *rafters* all 5. [For any other rate, multiply tabular quantity by  $\frac{1}{3}$ ].
- C. Iron-work in *tie-rod* and *rafter* of other rate, multiply tabular quantity by  $\frac{1}{16}$ ].
- D. Constant items, viz., wood-work in *cubic* foot. Iron-work in *nuts, heads, washers, bolts straps* =  $\frac{1}{2}$  maund at I, (here 16 Rs.)  $\frac{1+r}{27}$ ].

BREADTH.	SPAN.	18	19	20	21	22	23	24	25	26	27
4	A	9.03	9.67	10.29	10.92	11.55	12.15	12.79	13.42	14.06	14.69
	B	13.92	13.80	13.70	13.61	13.51	13.42	13.33	13.23	13.14	13.04
	C	15.16	15.80	16.44	17.09	17.78	18.54	19.38	20.21	21.03	21.85
	D	15.00	14.21	13.50	12.86	12.27	11.73	11.23	10.77	10.34	9.94
Total,		53.11	53.48	53.98	54.48	55.00	55.52	56.04	56.56	57.08	57.60
5	A	8.39	8.97	9.55	10.17	10.78	11.39	12.00	12.61	13.22	13.83
	B	13.67	13.56	13.46	13.36	13.26	13.16	13.06	12.96	12.86	12.76
	C	14.07	15.71	16.36	17.00	17.81	18.50	19.19	19.88	20.57	21.26
	D	12.00	11.37	10.80	10.28	9.81	9.38	8.99	8.63	8.30	7.99
Total,		48.13	49.61	50.17	50.81	51.47	52.14	52.81	53.48	54.15	54.82
6	A	7.90	8.44	8.99	9.55	10.15	10.78	11.41	12.04	12.67	13.30
	B	13.50	13.39	13.27	13.16	13.05	12.94	12.83	12.72	12.61	12.50
	C	15.02	15.66	16.30	16.94	17.58	18.22	18.86	19.50	20.14	20.78
	D	10.00	9.47	9.00	8.57	8.15	7.75	7.36	6.98	6.61	6.25
Total,		46.42	46.96	47.58	48.26	48.97	49.71	50.48	51.28	52.11	52.96
7	A	7.50	8.02	8.54	9.07	9.61	10.16	10.71	11.26	11.81	12.36
	B	14.70	14.59	14.49	14.40	14.30	14.21	14.11	14.02	13.92	13.83
	C	14.97	15.62	16.25	16.90	17.58	18.26	18.94	19.62	20.30	20.98
	D	8.56	8.12	7.71	7.34	6.98	6.63	6.30	5.98	5.67	5.36
Total,		45.73	46.35	46.99	47.71	48.49	49.31	50.17	51.06	51.98	52.92
8	A	7.18	7.67	8.17	8.68	9.20	9.73	10.26	10.79	11.32	11.85
	B	16.90	16.80	16.70	16.62	16.54	16.46	16.38	16.30	16.22	16.14
	C	14.94	15.59	16.23	16.87	17.52	18.17	18.82	19.47	20.12	20.77
	D	7.50	7.10	6.75	6.43	6.13	5.84	5.56	5.29	5.03	4.78
Total,		46.54	47.16	47.85	48.60	49.38	50.20	51.06	51.95	52.87	53.81



OF TABLE.

$$A = r' \left[ .583 (L. = \text{half value for full bay.} \right.$$

$$B \left\{ \begin{array}{l} \text{(Below } \beta = 6 = \text{value for full bay} + \frac{16.5 r}{\beta} \\ \text{(Above } \beta = 6 = 1\frac{1}{2} \text{ times value for full bay.} \end{array} \right.$$

$$C = \frac{2.353 (L - \dots)}{\beta L}$$

ly at 10 square inches section.  
under these rates, is from 6 to 7 feet.

Scantlings of rafter centres.			Cost per 100 s. f. covered, including wall-plates 4" x 6".	If other rates (r) be taken, multiply these values by $\frac{r}{3}$ .	Cost at corresponding rates of beam and rafter roof per 100 superficial feet covered [reducing item A from r = 2 to r = 1.5] spacing minimum.
SPAN.	BREADTH.	4			
10	5½ x		19.5		
11	5½ "		20.6		
12	6 "	1	22.1		
13	6½ "	1	23.9		
14	6½ "	1	25.9		
15	7 "	1	28.0	29½	
16	7½ "	1	30.3*	30½	
17	7½ "		32.8	32	
18	8 "		35.4	33½	
19	8½ "		38.0	34½	
20	8½ "		40.8	36	

Working equations are derived from  $sW = p_b \frac{bd^2}{L}$  (central loading) in which  $W = 100$  lbs. (distributed) per sup. feet  $p_b = 500$  (these tables being for deodar) Safety factors = 10,  $b = .63d$ . The above equation becomes

$$d^3 = \frac{WL}{32}; b = .63d$$

The working equation is expressed in terms of  $\beta$ , the distance between centres of beams.

For beams  $d = 1.16 \sqrt[3]{\beta L^2}, b = .63d$ .  
For rafters (1 foot apart)

$$d = 1.16 \sqrt[3]{L^2} b = .63d.$$

The table of cost of single rafter roofing is calculated from

$$r \left[ .583 (L + 1) \sqrt[3]{L + \frac{33.3}{L}} \right].$$

half per cent. being added to cover differences of working scantling.

\* Beyonders.



ROUND LOGS.—Contents per foot run—square  
of  $\frac{1}{2}$  Girth.

LINEAR.

11				12
02	02	02	02	08
04	04	04	04	04
06	06	06	06	06
08	08	08	08	08
09	10	10	10	10
11	12	12	12	12
13	14	14	14	15
15	16	16	16	17
17	18	18	18	19
19	19	20	20	21
21	21	22	22	23
23	23	24	24	25
25	25	26	26	27
27	27	28	29	29
29	29	30	31	31
31	31	32	33	33
32	33	34	35	35
34	35	36	37	37
36	37	38	39	40
38	39	40	41	42
40	41	42	43	44
42	43	44	45	46
44	45	46	47	48
46	47	48	49	50
48	49	50	51	52
49	51	52	53	54
52	53	54	55	56
53	55	56	57	58
55	57	58	59	60
57	59	60	61	62
59	60	62	63	65
61	62	64	65	67
63	64	66	67	69
65	66	68	69	71
67	68	70	71	73
69	70	72	73	75
71	72	74	75	77
73	74	76	77	79
74	76	78	80	81
76	78	80	81	83
78	80	82	84	85
80	82	84	86	87
82	84	86	88	90
84	86	88	90	92
	88	90	92	94
	92	94		96
	96			98
	12			100

Girth.	Section.	Girth.	Section.	Girth.	Section.	Inches.	Feet.
ft. in.		ft. in.		ft. in.		0	'000
2 0	0'25	6 0	2'25	10 0	6'25		'021
1	0'27	1	2'31	1	6'35		'042
2	0'29	2	2'38	2	6'46		'062
3	0'32	3	2'44	3	6'56	1	'083
4	0'34	4	2'51	4	6'67		'104
5	0'36	5	2'57	5	6'78		'125
6	0'39	6	2'64	6	6'89		'146
7	0'42	7	2'71	7	7'00	2	'167
8	0'44	8	2'78	8	7'11		'187
9	0'47	9	2'85	9	7'22		'208
10	0'50	10	2'92	10	7'33		'229
11	0'53	11	2'99	11	7'45		'250
3 0	0'56	7 0	3'06	11 0	7'56	3	'271
1	0'59	1	3'14	1	7'68		'292
2	0'63	2	3'21	2	7'79		'312
3	0'66	3	3'28	3	7'91	4	'333
4	0'70	4	3'36	4	8'03		'354
5	0'73	5	3'44	5	8'15		'375
6	0'76	6	3'52	6	8'27		'396
7	0'80	7	3'59	7	8'39	5	'417
8	0'84	8	3'67	8	8'51		'437
9	0'88	9	3'75	9	8'63		'458
10	0'92	10	3'83	10	8'75		'479
11	0'96	11	3'92	11	8'87		'500
4 0	1'00	8 0	4'00	12 0	9'00	6	'521
1	1'04	1	4'08	1			'542
2	1'08	2	4'17	2			'562
3	1'13	3	4'25	3		7	'583
4	1'17	4	4'34	4			'604
5	1'22	5	4'43	5			'625
6	1'27	6	4'52	6			'646
7	1'31	7	4'60	7		8	'667
8	1'36	8	4'69	8			'687
9	1'41	9	4'79	9			'708
10	1'46	10	4'88	10			'729
11	1'51	11	4'97	11		9	'750
5 0	1'56	9 0	5'06				'771
1	1'62	1	5'16				'792
2	1'67	2	5'25				'812
3	1'72	3	5'35			10	'833
4	1'78	4	5'44				'854
5	1'83	5	5'54				'875
6	1'89	6	5'64				'896
7	1'95	7	5'74			11	'917
8	2'01	8	5'84				'937
9	2'07	9	5'94				'958
10	2'13	10	6'04				'979
11	2'19	11	6'15				

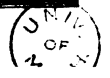




TABLE IV.

FLAT BAR SCANTLINGS ADMISSIBLE FOR TIE-RODS.

(First named to be preferred.)

Span, ...	18	19	20	21	22	23	24	25	26	27	
Calculated weight per ft., }	2'992	3'158	3'324	3'490	3'656	3'823	3'989	4'155	4'321	4'487	
Beams, 6 ft., centre to centre, ...	$2 \times \frac{7}{8}$ $1\frac{1}{2} \times \frac{3}{4}$ $2\frac{1}{2} \times \frac{1}{2}$ $2\frac{1}{2} \times \frac{3}{8}$	$1\frac{1}{2} \times \frac{3}{4}$ $2\frac{1}{2} \times \frac{1}{2}$ $2\frac{1}{2} \times \frac{3}{8}$ $2\frac{1}{2} \times \frac{3}{8}$	$2 \times \frac{3}{4}$ $2\frac{1}{2} \times \frac{1}{2}$ $2\frac{1}{2} \times \frac{3}{8}$ $2\frac{1}{2} \times \frac{3}{8}$	$1\frac{1}{2} \times \frac{3}{4}$ $2\frac{1}{2} \times \frac{1}{2}$ $2\frac{1}{2} \times \frac{3}{8}$ $2\frac{1}{2} \times \frac{3}{8}$	$1\frac{1}{2} \times \frac{3}{4}$ $2\frac{1}{2} \times \frac{1}{2}$ $2\frac{1}{2} \times \frac{3}{8}$ $2\frac{1}{2} \times \frac{3}{8}$	$1\frac{1}{2} \times \frac{3}{4}$ $2\frac{1}{2} \times \frac{1}{2}$ $2\frac{1}{2} \times \frac{3}{8}$ $2\frac{1}{2} \times \frac{3}{8}$	$1\frac{1}{2} \times \frac{3}{4}$ $2\frac{1}{2} \times \frac{1}{2}$ $2\frac{1}{2} \times \frac{3}{8}$ $2\frac{1}{2} \times \frac{3}{8}$	$1\frac{1}{2} \times \frac{3}{4}$ $2\frac{1}{2} \times \frac{1}{2}$ $2\frac{1}{2} \times \frac{3}{8}$ $2\frac{1}{2} \times \frac{3}{8}$	$2 \times \frac{3}{4}$ $2\frac{1}{2} \times \frac{1}{2}$ $2\frac{1}{2} \times \frac{3}{8}$ $2\frac{1}{2} \times \frac{3}{8}$	$2\frac{1}{2} \times \frac{3}{4}$ $2\frac{1}{2} \times \frac{1}{2}$ $2\frac{1}{2} \times \frac{3}{8}$ $2\frac{1}{2} \times \frac{3}{8}$	$2\frac{1}{2} \times \frac{3}{4}$ $2\frac{1}{2} \times \frac{1}{2}$ $2\frac{1}{2} \times \frac{3}{8}$ $2\frac{1}{2} \times \frac{3}{8}$
Round iron,	$1\frac{1}{2}$	$1\frac{1}{2}$	$1\frac{1}{2}$	$1\frac{1}{2}$	$1\frac{1}{2}$	$1\frac{1}{2}$	$1\frac{1}{2}$	$1\frac{1}{2}$	$1\frac{1}{2}$	$1\frac{1}{2}$	
Square iron,	$1\frac{1}{8}$	1	1	1	$1\frac{1}{8}$	$1\frac{1}{8}$	$1\frac{1}{8}$	$1\frac{1}{8}$	$1\frac{1}{8}$	$1\frac{1}{8}$	
	Hd. patn., No. 1, $1\frac{1}{4}$ " screw.			Head pattern, No. 1, $1\frac{1}{4}$ " screw.				H. P., No. 3, $1\frac{1}{4}$ ".			
Calculated weight per ft., }	3'400	3'684	3'878	4'072	4'266	4'460	4'654	4'848	5'041	5'235	
Beams, 7 ft., centre to centre, ...	$1\frac{1}{2} \times \frac{3}{4}$ $2\frac{1}{2} \times \frac{1}{2}$ $2\frac{1}{2} \times \frac{3}{8}$ $2\frac{1}{2} \times \frac{3}{8}$	$1\frac{1}{2} \times \frac{3}{4}$ $2\frac{1}{2} \times \frac{1}{2}$ $2\frac{1}{2} \times \frac{3}{8}$ $2\frac{1}{2} \times \frac{3}{8}$	$1\frac{1}{2} \times \frac{3}{4}$ $2\frac{1}{2} \times \frac{1}{2}$ $2\frac{1}{2} \times \frac{3}{8}$ $2\frac{1}{2} \times \frac{3}{8}$	$1\frac{1}{2} \times \frac{3}{4}$ $2\frac{1}{2} \times \frac{1}{2}$ $2\frac{1}{2} \times \frac{3}{8}$ $2\frac{1}{2} \times \frac{3}{8}$	$2 \times \frac{3}{4}$ $2\frac{1}{2} \times \frac{1}{2}$ $2\frac{1}{2} \times \frac{3}{8}$ $2\frac{1}{2} \times \frac{3}{8}$	$2\frac{1}{2} \times \frac{3}{4}$ $2\frac{1}{2} \times \frac{1}{2}$ $2\frac{1}{2} \times \frac{3}{8}$ $2\frac{1}{2} \times \frac{3}{8}$	$2\frac{1}{2} \times \frac{3}{4}$ $2\frac{1}{2} \times \frac{1}{2}$ $2\frac{1}{2} \times \frac{3}{8}$ $2\frac{1}{2} \times \frac{3}{8}$	$2\frac{1}{2} \times \frac{3}{4}$ $2\frac{1}{2} \times \frac{1}{2}$ $2\frac{1}{2} \times \frac{3}{8}$ $2\frac{1}{2} \times \frac{3}{8}$	$2\frac{1}{2} \times \frac{3}{4}$ $2\frac{1}{2} \times \frac{1}{2}$ $2\frac{1}{2} \times \frac{3}{8}$ $2\frac{1}{2} \times \frac{3}{8}$	$2\frac{1}{2} \times \frac{3}{4}$ $2\frac{1}{2} \times \frac{1}{2}$ $2\frac{1}{2} \times \frac{3}{8}$ $2\frac{1}{2} \times \frac{3}{8}$	$2\frac{1}{2} \times \frac{3}{4}$ $2\frac{1}{2} \times \frac{1}{2}$ $2\frac{1}{2} \times \frac{3}{8}$ $2\frac{1}{2} \times \frac{3}{8}$
Round iron,	$1\frac{1}{2}$	$1\frac{1}{2}$	$1\frac{1}{2}$	$1\frac{1}{2}$	$1\frac{1}{2}$	$1\frac{1}{2}$	$1\frac{1}{2}$	$1\frac{1}{2}$	$1\frac{1}{2}$	$1\frac{1}{2}$	
Square iron,	...	$1\frac{1}{8}$	$1\frac{1}{8}$	$1\frac{1}{8}$	$1\frac{1}{8}$	$1\frac{1}{8}$	$1\frac{1}{8}$	$1\frac{1}{8}$	$1\frac{1}{8}$	$1\frac{1}{8}$	
	Head pattern, No. 2, $1\frac{1}{4}$ " screw.			Head pattern, No. 3, $1\frac{1}{4}$ " screw.				H. P., No. 4, $1\frac{1}{4}$ ".			

SCANTLINGS.

Pattern.	Head.	Shank.	Weld.
No. 1.	$1\frac{1}{2}$ "	$2" \times \frac{3}{4}"$	$2" \times \frac{1}{2}"$
" 2.	$1\frac{1}{2}$ "	$2" \times \frac{1}{2}"$	$2" \times \frac{3}{8}"$
" 3.	$1\frac{1}{2}$ "	$2" \times \frac{1}{2}"$	$2" \times \frac{3}{8}"$
" 4.	$1\frac{1}{2}$ "	$2" \times \frac{1}{2}"$	$2" \times \frac{3}{8}"$

TABLE OF BEAM SCANTLINGS.

Span.	18	19	20	21	22	23	24	25	26	27
Apart, } 6 feet,	$7 \times 2\frac{1}{2}$	$7\frac{1}{2} \times 2\frac{1}{2}$	$7\frac{1}{2} \times 2\frac{1}{2}$	$7\frac{1}{2} \times 2\frac{1}{2}$	$8 \times 2\frac{1}{2}$	$8\frac{1}{2} \times 2\frac{1}{2}$	$8\frac{1}{2} \times 2\frac{1}{2}$	$8\frac{1}{2} \times 2\frac{1}{2}$	$9 \times 2\frac{1}{2}$	$9\frac{1}{2} \times 2\frac{1}{2}$
Apart, } 7 feet,	$7\frac{1}{2} \times 2\frac{1}{2}$	$7\frac{1}{2} \times 2\frac{1}{2}$	$8 \times 2\frac{1}{2}$	$8\frac{1}{2} \times 2\frac{1}{2}$	$8\frac{1}{2} \times 2\frac{1}{2}$	$9 \times 2\frac{1}{2}$	$9 \times 2\frac{1}{2}$	$9\frac{1}{2} \times 2\frac{1}{2}$	$9\frac{1}{2} \times 2\frac{1}{2}$	$9\frac{1}{2} \times 2\frac{1}{2}$

N.B.—Each beam is formed of a pair of scantlings (vide Plate LV.) The dimensions in Table are those of one only of the pair.

Workshop Details.—Introduce  $\frac{1}{4}$ -inch leaden washers under the head nuts, and over struts, sockets, and putty between the iron washer plate and the wood, welds should be  $1\frac{1}{2}$  times bar scantling, and are best double fished say on 9-inch length.

Testing.—Load between piers with 200 lbs. per square foot, or for beams of 6 feet distance by pairs three, centre to centre, with a 6 foot breadth of platform carrying 16 courses of  $12" \times 6" \times 3"$  bricks, and keeping the beams cambered to half an inch\* not more, as it will introduce false strains. Iron will thus be strained to about 9 tons per square inch.

\* Or adopt following rule :—Camber 1 inch for 18 feet span, and an additional  $\frac{1}{8}$ -inch for every additional foot of span.





Now to examine the effect of this on the printed Table II, it appears from internal evidence in the Text that  $f_s = 8500$  lbs. (for the Timber used),  $s = 10$ .

Hence taking the extreme limits of the Table,

*Ex. 1.*  $\beta$  (spacing) = 4', L (span) = 18'. Scantling requisite for the Transverse Load (as given in Table),  $d = 6\frac{1}{2}$ ',  $\delta = 4$ '.

$$\therefore \delta' = \frac{74 \cdot 87 \times 10}{8500} \times \frac{4 \times 18}{6\frac{1}{2}} = 1' = \frac{1}{4} \delta, \text{ nearly.}$$

*Ex. 2.*  $\beta$  (spacing) = 8', L (span) = 27'. Scantling requisite for the Transverse Load (as given in Table)  $d = 10$ ',  $\delta = 6\frac{1}{2}$ '.

$$\therefore \delta' = \frac{74 \cdot 87 \times 10}{8500} \times \frac{8 \times 27}{10} = 2' = \frac{1}{3} \delta, \text{ nearly.}$$

Thus it appears that the breadths of scantling of Beam given in Table II, are *too small*, by an amount varying from  $\frac{1}{4}$  to  $\frac{1}{3}$  at the limits of the Table.

In defence of the method in this Paper of designing the scantling of a Bar which is under *both* Stresses, 1° and 2°, as simply the greater of the two scantlings requisite for either partial Stress, 1° or 2°, it may be observed that the mistake is commonly\* enough made. It may also be said that the adoption of a *large* factor of safety (*e. g.*, 10) renders it unnecessary to go to the trouble of taking into account the smaller of the two Stresses, 1° and 2°: this would not be justifiable unless it be proved that the smaller scantling is *only a small fraction* of the larger. And in the Tables under review this is *not the case*.

In using these Tables therefore it is clearly necessary either to *increase the breadth* of the scantlings of the Beam (about  $\frac{1}{4}$  to  $\frac{1}{3}$ ) in the manner indicated, or else to bear in mind that the Tabulated scantlings do not provide an "effective factor of safety" so large as 10.

A. C.

\* It was adopted in the "Roorkee Treatise of Civil Engineering," 1st and 2nd Editions, and in the separate Manuals published therefrom, also in Keay's "Scantlings of Timbers for Roofs."

## No. CXXIV.

## IMPROVED TYPES OF TRUCKS AND WHEELBARROWS.

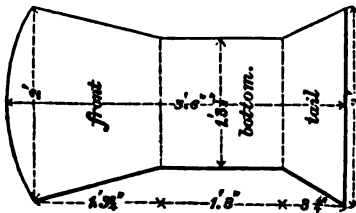
[Vide Plates LVI, LVII and LVIII.]

BY CAPT. J. L. L. MORANT, R.E., *Assoc. Inst. C.E., and F.R.G.S.*

To Public Works Officers in India, who have at once to perform the functions of Civil Engineers and Contractors, questions on the best kinds of plant, such as wheel-barrows and stone trucks, are of importance. Much depends on their form, and the materials of which they are made. Improved patterns of both were designed for this district by a Mechanical Engineer, and these have been amended from experience gained in their use. The types of both, last obtained, are herein described and illustrated.

*The Wheel-barrow.*—The two shafts and the connecting cross stays, which replace the usual boddy bolts, are of wood. These, morticed and tenoned together, form a platform on which the barrow box rests. The wheel and its axle are of cast-iron moulded in one piece. The rest of the

Fig. 1.

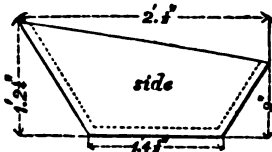


barrow of wrought. The barrow box is formed of three pieces of sheet-iron of the following shapes :—One of the form of Fig. 1, of  $\frac{1}{8}$ th of an inch thick, and two of the form of Fig. 2, of  $\frac{1}{8}$ th of an inch thick. The first piece is carefully bent at the dotted lines, and forms

the front, bottom, and tail of the barrow box ; the other two pieces, forming the sides, are riveted on to the first piece, so as to make up the

receptacle for the soil. The edges of this box are strengthened by pieces of  $\frac{1}{4}$ -inch bar iron  $\frac{1}{4}$ -inch wide riveted on to them. The two corner edges of the front of the barrow, where the strain is greatest, are double riveted.

Fig. 2.



This barrow box is screwed on to the wooden frame before-mentioned. The barrow legs are formed of  $\frac{1}{4}$ -inch bar iron. Their feet are studded. The whole of the wheel-barrow should be twice coated with boiling tar. One of them can hold one-tenth of a cubic yard of soil. It weighs unloaded 93 lbs.

It is so designed that nearly the whole weight of the load is thrown on the wheel and its axle. In the ordinary barrow too great a portion of this weight perhaps rests on the workman's forearm, and shoulder straps are sometimes used to relieve this pressure. Native coolies seem to prefer this to other wheel-barrows. Being formed of thin sheet iron it is not so heavy as a barrow of wood of the same capacity. It facilitates their use over heavy ground if they are run on planks as in England.

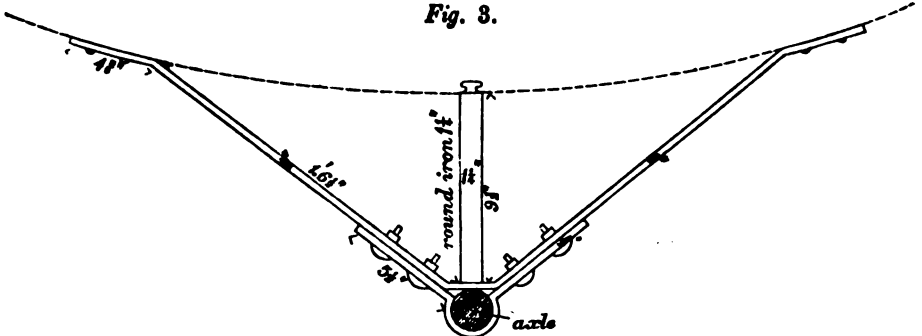
From Rankine the contents of a wheel-barrow in England seems to be only  $\frac{1}{10}$  of a cubic yard. Gillespie says they contain  $\frac{1}{10}$  to  $\frac{1}{10}$ . In Europe an average workman can shovel into a barrow, *per diem*, 22 cubic yards of ordinary soil which has previously been loosened, but in India he only shovels 12 cubic yards. The European workman is vigorous and rapid in the execution of the work, which he performs in a cold and bracing climate. The Indian is somewhat listless and slow, and works in a hot and enervating country. It thus seems fit that the former should be supplied with a different barrow to that with which the latter can best work. For the former, lengthened experience has proved a shallow barrow with splaying sides and a very short axle to be the best. But for the latter perhaps something of the kind illustrated is the most convenient.

*The Stone Truck.*—The stone truck is composed of two cast-iron wheels hung over turned gudgeons on a stout axle,  $2\frac{1}{4} \times 1\frac{3}{4}$  inches in the centre enlarging to  $2\frac{1}{4} \times 2$  inches at the extremities. To the ends of the axle and outside the wheels are attached two wrought-iron combinations of the accompanying form, (*Fig. 3.*) and to the centre portion of the axle inside of and between the wheels are fastened by bolts and nuts two pieces of wrought-iron of the following shape, (*Fig. 4.*)



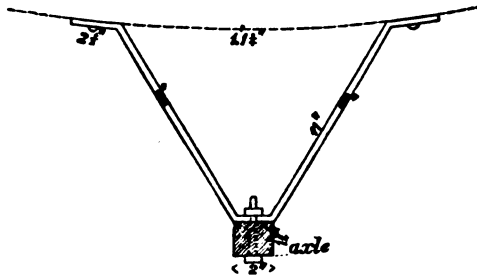
These four supports carry the truck platform, which in shape is the

Fig. 3.



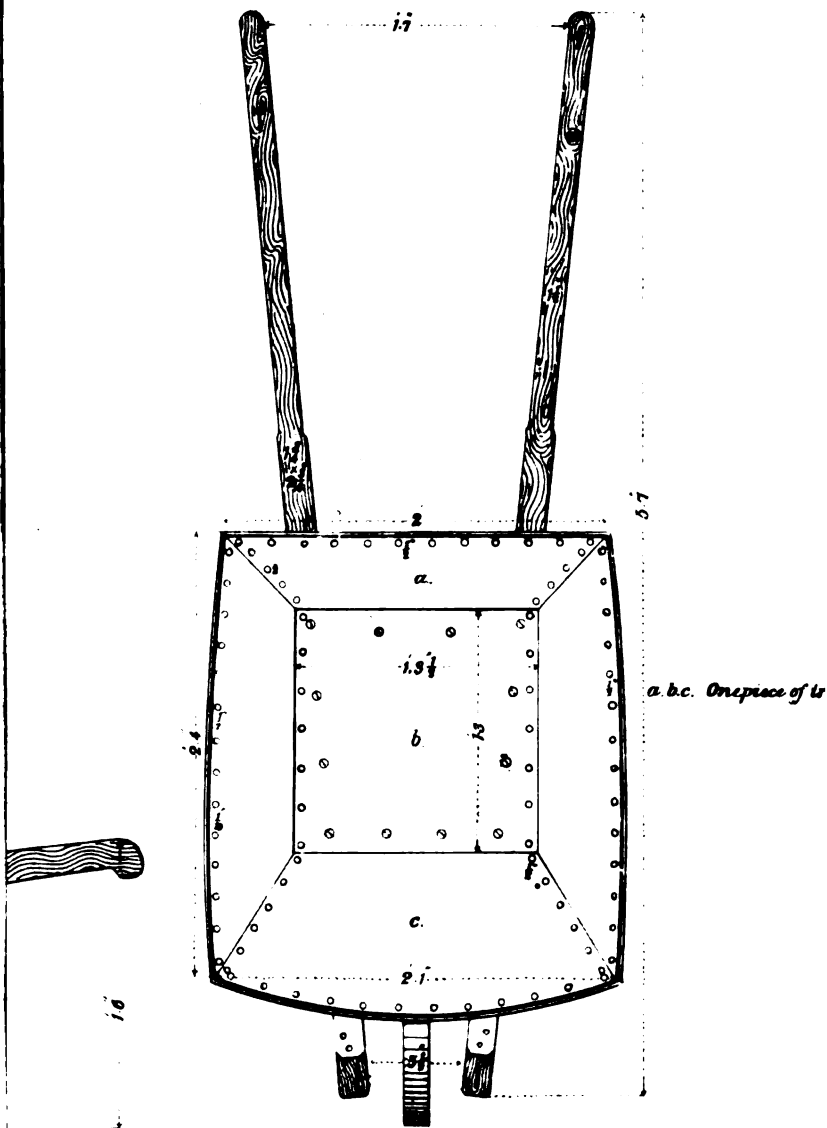
segment of a circle. The platform is enclosed on its four sides with angle irons (two of which are curved)  $\frac{1}{2}$ -inch thick  $\frac{3}{4}$  fastened at the cor-

Fig. 4.



ners by rivets with  $\frac{3}{8}$ -inch iron clamps. The curved irons are attached to the outer supports which rest on the axle. The back of this platform, where the wear and tear are greatest, is strengthened by an iron bar  $\frac{3}{4} \times 2$  inches, riveted on to the upper flange of the angle-iron. The platform has further two flat iron bars,  $\frac{3}{8} \times 1\frac{1}{2}$ -inches, of a segmental shape, laid lengthwise, their ends being riveted on to the under flanges of the angle irons which they meet. These bars lie directly over, and are fastened to the two centre wrought-iron supports, already specified, which are connected with the axle. To this iron framework of the platform three wooden planks,  $2\frac{1}{4}$  inches thick and  $1\frac{1}{4}$  inches apart, are riveted crosswise with square headed countersunk rivets. The whole truck is

Top Plan

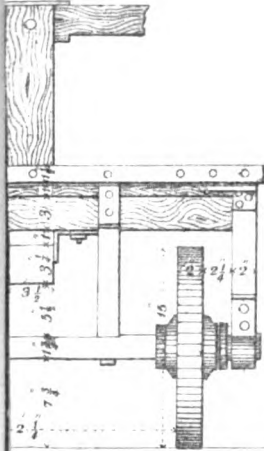




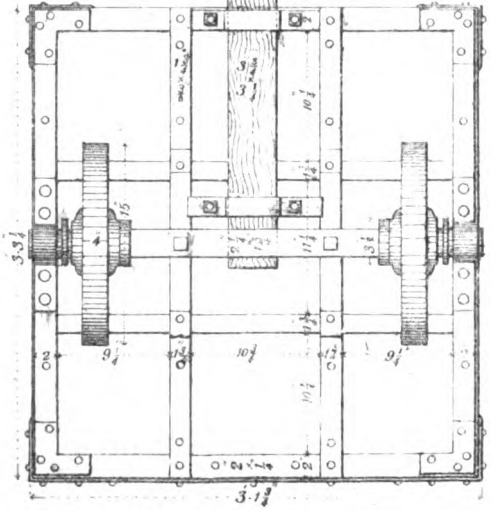
yard

Bottom Plan

Elevation .



$2\frac{1}{4}$

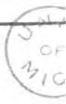
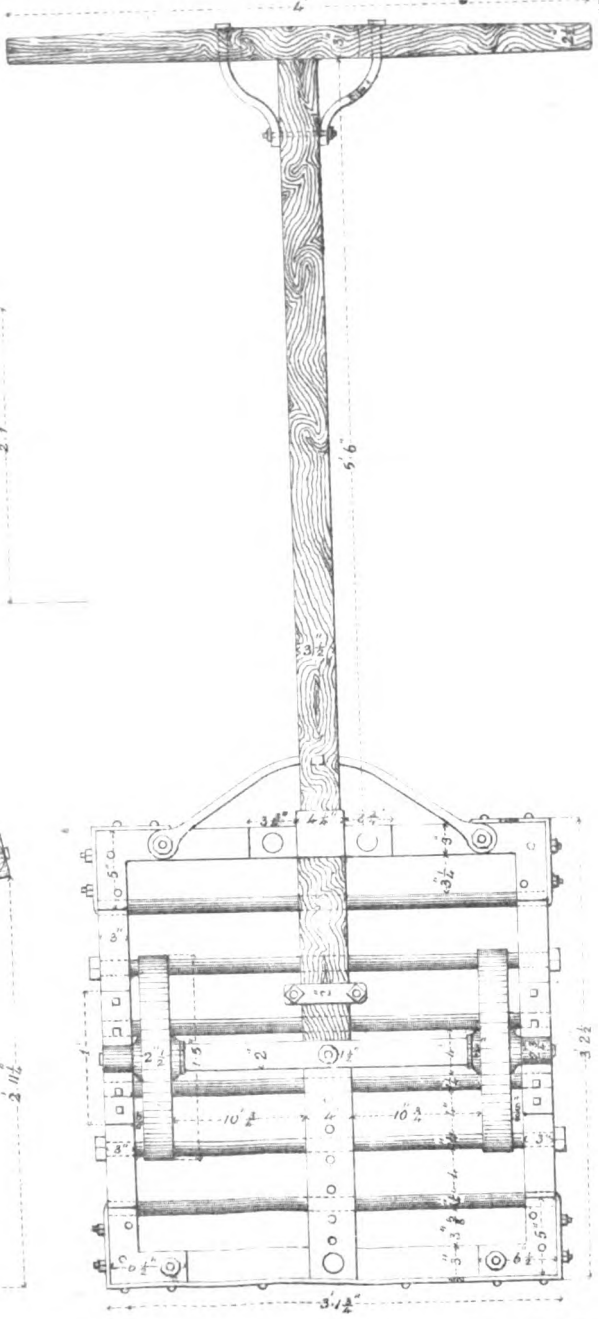
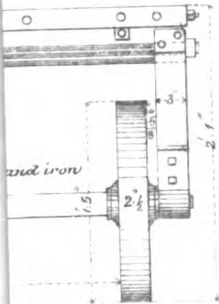




ard.

Bottom Plan

tion.





drawn by a wooden pole with cross handles fastened by two clamps below the platform as shown in *Plate LVII*. This truck can carry one ton, or half a cubic yard of stone, and weighs 436 lbs. By this arrangement the wooden planked floor is the part of the truck which first wears out. Successful efforts to strengthen this, the weakest part, have been made. Curved bars of iron,  $\frac{3}{8} \times 1\frac{1}{4}$  inches, are laid across the planks, and directly over the similar bars which support them below, (*see* dotted lines in left hand figure, *Plate LVII*). These pairs of iron bars are connected by stout rivets passing through the planks, and the rivet heads on the upper side of the platform, instead of being flat and countersunk, are bossed. This arrangement protects the planks, and in a great measure prevents the stones from cutting their fibres. It makes the truck more durable, but adds a little to its weight, and raises it to 456 lbs. The first arrangement is the best where the stones conveyed have no very sharp edges.

*Plate LVIII* illustrates another truck stronger than either of the two previous ones. Here the planking is done away with altogether, and is replaced by six circular  $1\frac{1}{4}$ -inch iron bars. These are laid across the truck floor, and let loosely with turned ends only  $\frac{5}{8}$ -inch diameter into the upper flanges of the side angle-irons, which are increased to  $\frac{3}{8}$ -inch in thickness. Two of these bars are threaded at their extremities, and have nuts. The other bars lie loose. The angle clamps instead of being riveted to the corners of the framed enclosure are fastened to them by small bolts and nuts. Thus the truck can be taken to pieces, and any injured part removed, repaired, and replaced. The iron bars forming the platform floor revolve in the holes of the side angle irons, and in this way assist in pushing the stone on to the truck. There are some other modifications which the plate clearly shows. This truck weighs 497 lbs., and can carry  $1\frac{1}{4}$ -ton or  $\frac{5}{8}$ ths of a cubic yard of stone. If these trucks are used over heavy ground the tyres of their wheels should be wider. These three trucks possess the following advantages:—Their wheels, being hung under the bearing platform, are protected from the constant injury to which those of the ordinary trucks are exposed; their curved shape; securely keeps the stone in its place, and aids in raising it on to and taking it off the truck; they are capable of carrying as large stones as can be handled by workmen without the help of cranes; and thus better work with large stones is obtained than if weaker trucks are used.

14th May, 1874.



No. CXXV.

---

ADJUSTMENT OF LEVELS, AND OF EVEREST AND  
TRANSIT THEODOLITES.

[*Vide* Plate LIX.]

---

By CAPT. ALLAN CUNNINGHAM, R.E., *Hon. Fell. of King's Coll. Lond.*

---

[The references are to Paper No. XLVII. of 'Professional Papers on Indian Engineering,' Second Series, "On Gravatt's Method," by the same author].

*Preface.*—It having been recently shown (in Paper No. XLVII.) that the process known as 'Gravatt's Method' of adjusting *in altitude* the 'Line of Collimation' of a Level altogether fails even to discover any existing error, and *à fortiori* fails in securing the adjustment wished, all Adjustments hitherto proposed which depend on 'Gravatt's Method' *should be absolutely rejected*—as being simply 'failures.'

[This of course invalidates the adjustments hitherto usually proposed\* for 'Gravatt's' or 'Dumpy Levels', and 'Troughton Level' for the 'Line of Collimation' *in altitude*, also that sometimes proposed† for 'Everest' and 'Transit Theodolites' for the same purpose—if dependent on 'Gravatt's Method' ].

*Principle of Adjustment proposed.*—The *construction* and *use* of the telescope are (*see* Paper No. XLVII.) such that after—

- 1°, duly focussing the hairs and field of view,
- 2°, removing any relative parallax of the hairs and field,

all points in the field of view *at whatever distance* which can be 'bisected' or 'covered' by the centre of the horizontal hair of a Level, or by the intersection of cross-hairs of a Theodolite will *lie on a certain straight line*, which may hence be conveniently called the VIRTUAL LINE OF SIGHT—(being the 'locus of points observed').

\* As in Thomason C. E. College Manual of Surveying, pages 178-181.

† As in Thomason C. E. College Manual of Surveying, pages 61, 62.

[This line ( $dF$  in figure) passes\* through the projection ( $d$ ) of the centre ( $q$ ) of horizontal hair of a Level, or of the intersection ( $q$ ) of cross-hairs of a Theodolite upon a plane ( $dC$ ) through the optical 'centre' ( $C$ ) of the object-glass, perpendicular to the object-glass-axis ( $oC$ ), and the outer principal focus ( $F$ ) of the object-glass].

It is obviously sufficient for practical use of the instruments that this VIRTUAL LINE OF SIGHT and the 'axis' of the telescope-level should be set *parallel to one another*, and that further in a Theodolite the 'mean line' of the vertical reading verniers should also be parallel to them: the object of the new adjustment is to effect this.

*Result of the Adjustment.*—When the Adjustment is complete the effect obtained will be—

1°. *In Levels.*—When the Telescope-level bubble is at the centre of of its run, the VIRTUAL LINE OF SIGHT will be *level*, and all points at *whatever distance*, which can be properly seen and covered by the centre of the horizontal hair *will lie on that line*.

2°. *In Theodolites.*—When the Telescope-level bubble is at the centre of its run, and the mean reading of the vertical arcs zero, then the VIRTUAL LINE OF SIGHT will be *level*:—The 'mean line' of the vertical reading verniers, and the object-glass axis will, however, be *usually not level* at this time; but they will be equally inclined to the horizon, for their actual state will be—

$$\left. \begin{array}{l} \text{Inclination of 'mean line' of vertical} \\ \text{reading verniers to the telescope-} \\ \text{level-axis, i. e., to horizon,} \end{array} \right\} = \left\{ \begin{array}{l} \text{Inclination of object-glass-} \\ \text{axis to Virtual Line of} \\ \text{Sight, i. e., to horizon.} \end{array} \right.$$

If now the telescope be raised (or depressed) through any angle, the angle *read* on the vertical arcs will (by the construction of the instrument) be the angle of elevation of the telescope-axis *affected by the initial inclination of the mean line of verniers to the horizon* ( $\pm$  as the case may be), i. e., will be the real angle of elevation of the VIRTUAL LINE OF SIGHT—(the angle really required).

Moreover, all points at *whatever distance* which can be properly seen and covered by the intersection of the cross-hairs—without moving the telescope in altitude—will *lie on that straight line*, and may therefore be said to be a series of points of *the same angular elevation* (or depression).

[It is believed that no adjustment hitherto proposed has yet effected this result—which is clearly the result really required)—for an Everest or Transit Theodolite,

\* This is proved in Paper No. XLVII. .A demonstration of this property is also given in Art. 50 of Rankine's 'Manual of Civil Engineering', but the *reasoning is incorrect*; this has been pointed out in (the author's) Paper No. XXI. of 'Professional Papers on Indian Engineering', Second Series.

except indeed at very long distances, *i. e.*, for solar focus, for which (in consequence of using a 'constant focus') a simpler adjustment will suffice].

**Gravatt or Dumpy Level, Troughton Level.**—The necessary adjustments *may* be performed in a somewhat different manner, and even in a different order, in each of these instruments, according to the manner of mounting. The following process is, however, recommended as being alike *applicable to them all*—a matter of some importance when levels of different patterns have to be entrusted to Subordinates.

The necessary adjustments are *only two*.

1°. *Adjustment of the Level.\**—The object of this adjustment is to set the large telescope-level perpendicular to the vertical axis of motion.

*Preliminaries.*—Bring the foot-screws to the middle of their runs, and then set up the level with the horizontal plate or compass-plate as nearly level as the eye can judge by simply using the legs. Bring the large level over any foot-screw, and bring its bubble to the centre *by means of that foot-screw*. Turn the large level through a right angle, and bring its bubble to the centre again *by means of the remaining pair of foot-screws* (to which it should then be parallel). Now turn the large level back to its original position, and repeat the process of bringing the bubble to the centre (if it has been displaced) in both the positions at right angles, until the bubble remains at the centre in both positions. The vertical axis of motion will now be *nearly vertical* and the level-axis *nearly horizontal*.

[*Caution.*—Care must be taken on repeating the process, that in both positions at right angles, the large level occupies the same position as in the first trial, *i. e.*, that it is *not reversed end for end*, which can easily be prevented by watching the telescope].

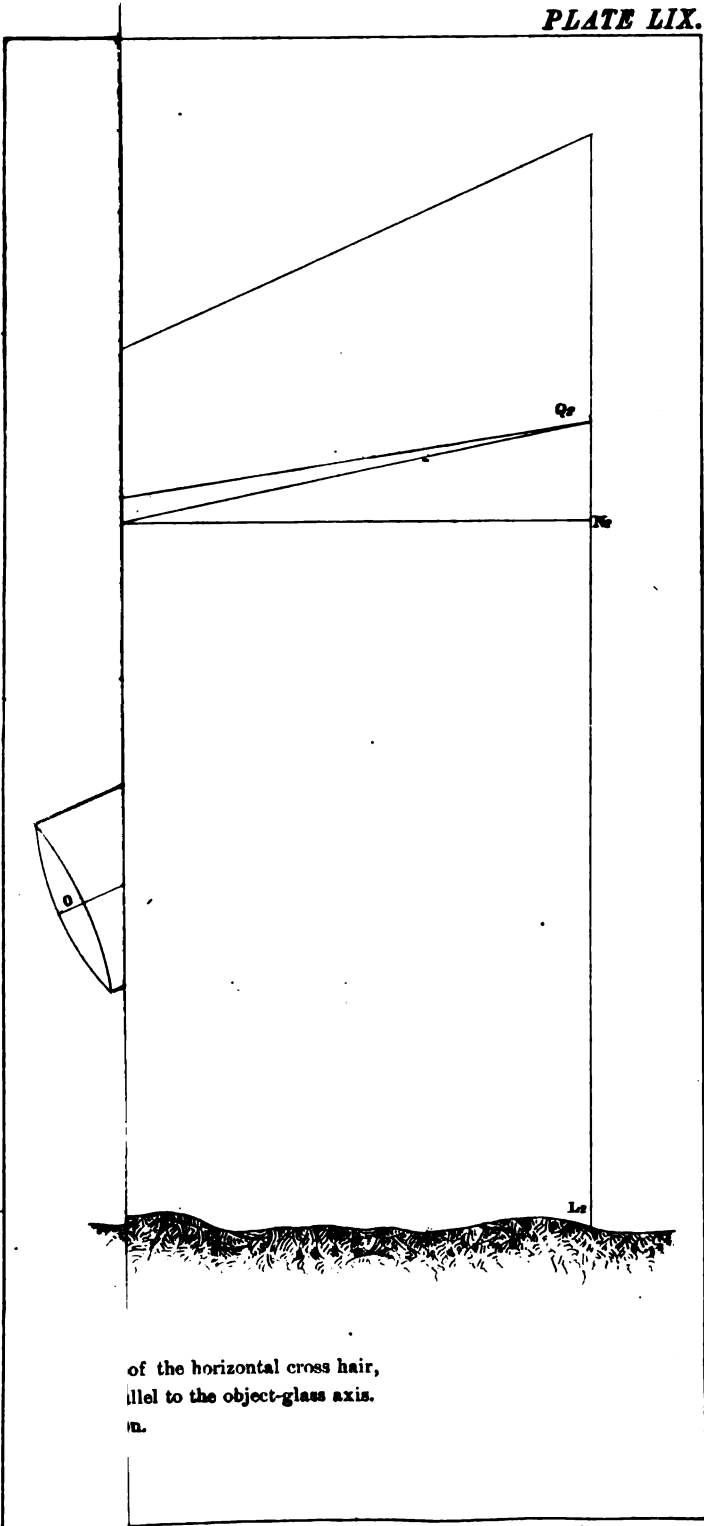
*Adjustment.*—Place the large Level over any chosen foot-screw, and bring its bubble to the middle by that foot-screw. Next gently reverse the Level end for end (round the vertical axis). Any deviation of the bubble from the middle is double the real error of perpendicularity of the Level-axis to the vertical axis of motion. Correct *half this apparent deviation* by the † "Level-screws" or ‡ lower "Telescope Screws"; if the half be correctly estimated, this *completely corrects the error*, but this requires further trial.

Correct the remaining half deviation, *i. e.*, bring the bubble to the centre by the foot-screw. Reverse the level again end for end. Any remaining deviation of the bubble is double the remaining error: half that deviation is to be corrected as before by the "Level-screws" or lower "Telescope-screws" which if correctly judged completes the adjustment. Bring the bubble to the centre by the foot screw, and repeat the process until the Level will bear reversing without displacing the bubble from its centre.

\* This Adjustment is the same as usually given: it is repeated here solely to complete the Adjustments of Level.

† The "Level-screws" are those which carry the level (on the Telescope).

‡ The "Telescope-screws" are those which carry the Telescope (on the lower Bar).



of the horizontal cross hair,  
parallel to the object-glass axis.  
n.





[*Caution.*—During the above process, which will take some time, the large level should occasionally be placed at right angles to the position above described; if the bubble leaves the centre it should be brought back to the centre by the remaining pair of foot-screws—to which pair it would then be parallel].

Finally, the level should bear turning to any position without displacing the bubble from the centre of its run.

If after several trials this Adjustment cannot be effected, the Instrument is useless.

*Cross-level.*—Some Levels are fitted with a small level at right angles to the large level. When the Adjustment of the large level is complete as above, the Cross-level bubble should be in the middle of its run; if it be not, the bubble should be brought to the centre by the cross-level-screws.

[*Caution.*—No reliance should be placed on the indications of the cross-level until this has been done].

2°. *Adjustment of the "virtual line of sight".*—The object of this adjustment is to set the "virtual line of sight" parallel to the (previously corrected) level axis. The process consists in bringing the "virtual line of sight" level by means of the diaphragm-screws, whilst the level-axis is kept level by the foot-screws.

STEP I. *To trace a level line in the air.*—Place two pegs  $L_1$ ,  $L_2$  at any convenient distance (say 150 feet) apart on a tolerably level piece of ground soft enough to admit of easily driving pegs. Bisect the distance between them, and place the Level to be adjusted over this middle point with the aid of a plummet, with the horizontal plate or compass plate as nearly level as the eye can judge by simply using the legs. Direct the telescope on a levelling Staff placed on either peg: focus the hairs and figures on the Staff and at the same time destroy any relative parallax (of the hairs and figures on the Staff) by means of the eye-piece motion, and focussing screw.

Next make the vertical axis of motion, (as yet only approximately vertical) truly vertical by means of the foot-screws in the same manner as described for the first adjustment, so that the level axis may traverse a horizontal plane.

Direct the telescope (already properly focussed) on the levelling Staff placed upright on the peg  $L_1$  and record the reading, next reverse the telescope gently (round the vertical axis), and record the reading on the same Staff removed to the peg  $L_2$ .

The difference (if any) of these readings will be the true difference of level of the tops of the pegs  $L_1$ ,  $L_2$  (notwithstanding instrumental errors).

Next gently tap the *higher* of the two pegs (this corresponds to the *lesser* reading) into the ground. Place the Staff on it and again observe the reading. Continue tapping whichever peg is the *higher* into the ground until the reading on the Staff is the same on both pegs. This can be easily done after a few trials. The tops of the pegs will now be on the *same level*.

[*Caution.*—The tops of the pegs should be carefully rounded. The *same* Staff should be used for both pegs, both in this and the next process, as the differences of graduation of different staves might introduce an error larger than the existing error of line of collimation. The act of moving the eye-piece frequently disturbs the Level: for this reason it is directed above to complete the focussing *before* finally setting the vertical axis of motion vertical. See also Caution at end of Step II].

**STEP II.** *To set the "virtual line of sight" level.*—Remove the level on to the line  $L_1 L_2$ , produced at a sufficient distance from the nearer peg to admit of distinctly reading the Staff when placed thereon. Make its vertical axis of motion vertical by means of the foot-screws: this sets the level-axis horizontal. Direct the telescope towards the pegs, and record the readings on the same staff placed on each in succession after duly focussing without parallax in each case.

If these readings differ, the 'virtual line of sight' is not level, in which case it must be tilted by shifting the diaphragm up or down with the diaphragm screws—watching the effect on the readings on the staff through the telescope. [*N.B.*—The diaphragm should be moved *up*, if the reading on the further staff *exceed* that on the nearer; and *vice versa*].

Repeat the readings on the staff on either peg, and continue shifting the diaphragm until the readings become precisely the same. The virtual line of sight will then be a horizontal line, and therefore parallel to the level-axis (which was set horizontal at the beginning of Step II).

[*Caution.*—It is necessary that the bubble of the large level should be kept at the centre of its run throughout the whole process of both Steps I. and II. It is advisable that the bubble of the cross level be also kept at the centre of its run. Any deviation in either bubble should be corrected by the foot-screws. It will be found convenient to set the Level up with one of the foot-screw arms in the plane of the staves, as this enables the large and cross levels to be moved *immediately and independently*, the former by the foot-screw in that plane and the latter by the remaining pair of foot-screws—a matter of considerable convenience].

[*N.B.*—It will be seen that *only one* of the two sets of screws termed "Level-screws", and "Telescope-screws" is used in the preceding Adjustments. It is immaterial which is used.

"Gravatt's Level", ordinary pattern, is fitted with both sets—and as made by Cooke with only the "Level-screws".

"Troughton's Level" is fitted with only the Telescope screws].

[Processes almost identical with the preceding have frequently been published before, but the Result has generally been *mis-stated* to be the 'Adjustment of the line of collimation in altitude'. The real Result is simply that the Virtual Line of Sight and Level-axis are set parallel].

**Transit and Everest Theodolites.**—The necessary Adjustments of the Transit and Everest Theodolites will be only three in number, viz. :—

- |   |                         |
|---|-------------------------|
| 1°. Adjustment of the lower level,                      | } As usually described. |
| 2°. Adjustment of the "line of collimation" in azimuth, |                         |

3°. Adjustment of the upper level and "virtual line of sight."—The object of this adjustment is to set the telescope level-axis at the same inclination to the mean line of the vertical reading verniers that is included between the "virtual line of sight" and telescope-axis.

[The adjustment hitherto proposed has aimed at setting the telescope level-axis parallel to the mean line of the vertical arc verniers, but *has failed in effecting this*

to the extent of the error (in altitude) of the line of collimation, in fact the effect of two errors (i. e.,  $1^\circ$  of 'mean line' of the vertical arc verniers, and  $2^\circ$  of line of collimation in altitude) have commonly been confused together, and neither really eliminated].

The process consists in making the "virtual line of sight" and telescope level-axis simultaneously horizontal, at the same time that the mean vertical reading is zero.

[*Caution.*—It is essential that the two first Adjustments should have been performed before attempting the third].

STEP I. *To trace a level line in the air.*—This is most easily done with a level as described under Adjustment  $2^\circ$  for Levels; it may be done with the Theodolite itself with a slight modification of the same process, as follows:—

Set the instrument up over the point midway between the pegs A, B, and level its horizontal plates by means of the lower level and foot-screws. Tighten the stud-screws and clamp the vertical axis in any convenient position—say at zero.

Proceed as in Step I. of the similar process for Levels: the reversal of the telescope is always to be done by gently turning round its vertical axis.

[*Caution.*—After once tightening the stud-screws and clamping the vertical arcs as above, the stud-screw, vertical arc-clamp, and tangent-screw, must not be touched throughout the remainder of the process.

If there be *no vertical arc-clamp*,—as is the case in small single-arc Everest Theodolites—the arc should be set to zero *before making each reading* on the Staff and again examined after the reading: the reading should be rejected if the arc is not still at zero.

The horizontal plates *must be kept level throughout*: the lower level alone can be trusted to for determining this—(the upper level is of no use for this purpose): any deviation of the bubble (of the lower level) from its centre is to be corrected by the foot-screws].

STEP II. *To set both the telescope level-axis and "virtual line of sight" horizontal, whilst the vertical arcs read zero.*—This step must be differently performed according as the instrument is fitted with or without "Upper Level-screws", and "Vertical Diaphragm-screws". Either method is applicable to instruments which are fitted with both.

[*N.B.*—TRANSIT THEODOLITES are fitted with both sets of screws.

DOUBLE ARC EVEREST Theodolites are fitted sometimes with both sets of screws, sometimes with only "Upper Level-screws".

SINGLE ARC EVEREST Theodolites are usually without "Upper Level-screws"].

*Adjustment.*—Remove the instrument on to the line A, B, *produced*, at a sufficient distance from the nearer peg to admit of distinctly reading the Staff when placed thereon. Level its horizontal plates by means of the lower level and foot-screws.



Proceed by one of the following methods according to the manner of mounting.

**METHOD (a).\*** *For an instrument without vertical "diaphragm-screws".*

Clamp the vertical arcs so that their mean reading shall be zero. Direct the telescope towards the pegs with the "Stud-screws" tightened so as to bring the upper level bubble near the centre of its run, so that the "virtual line of sight" may be nearly horizontal; and record the readings on the same staff placed successively on either peg—after duly focussing without parallax in each case.

[*Caution.*—The vertical arc-clamp and tangent-screw must not be touched after once setting to zero].

If these readings differ, the "virtual line of sight" is not really level, in which case it must be tilted by gently tilting the whole upper works by means of the "stud-screws"—watching the effect on the readings on the staff through the telescope.

[*N.B.*—The object-glass is to be *depressed* if the reading on the further staff exceed that on the nearer, and *vice versa*].

Repeat the readings on the staff on either peg, and continue tilting the telescope (by means of the stud-screws) until the readings become *precisely the same*.

The "virtual line of sight" will then be a horizontal line. The above procedure will probably have disturbed the telescope level: its bubble is now to be brought back to the centre by means of the "Upper Level-screws".

**METHOD (b).** *For an instrument without "Upper Level-screws".*

[*N.B.*—The method will be described as applied to a small Single Arc Everest Theodolite, which has neither vertical-arc-clamp, nor tangent-screw, nor upper level-screws].

Direct the telescope towards the pegs. Bring the upper level bubble to the centre of its run by means of the stud-screws. As the lower plates were previously set horizontal, and the vertical axis of motion therefore vertical, the upper level will be perpendicular to that vertical axis, and the remainder of the process is quite similar to that of Step II. for levels, *q. v.*, with the slight modification that *just before recording* the reading on each staff, the telescope must be focussed without parallax and the vertical arc set to zero by means of its rack and pinion.

[*Caution.*—If the vertical arc has no 'clamp', the level and vertical arc reading should be examined both before and after recording a reading on either staff. If the level-bubbles are not both at the centres, or the vertical arc not at zero immediately after recording a reading, that reading should be rejected].

*Result of Methods (a), (b).*—The upper level axis and "virtual line of sight" will now be both horizontal, whilst the vertical arcs are at their zero, so that in future a zero mean reading on the vertical arcs with the upper level bubble at the centre *will indicate the horizontality of the "virtual line of sight"*.

[*Caution.*—The adjustment described is obviously effective *only for the original position of the face of the vertical arcs.*—If the "face be changed" the adjustment is of no use].

*Remarks.*—Neither the 2nd nor 3rd Adjustment are absolutely necessary in a Transit or Double-Arc Everest Theodolite; nor is the 2nd Adjust-

\* This METHOD was suggested to the author by Lieut. M. H. Gregson, R.E.

ment absolutely necessary in a Single-Arc Everest Theodolite. The simple expedient of observing every point twice (or an even number of times) with the face of the vertical arcs in opposite positions on each occasion *eliminates all errors* due ( $1^\circ$ ) to non-adjustment of the Line of Collimation and 'mean line of the verniers' in the case of the Transit and Double-Arc Everest Theodolite, and ( $2^\circ$ ) to non-adjustment of the Line of Collimation in *azimuth only* in the Single-arc Everest Theodolite.

The adjustments are however convenient, and the 3rd Adjustment is *necessary* for good vertical readings in the Single-Arc\* Everest Theodolite, inasmuch as vertical angles can be read with it in only one position of the face.

A. C.

\* Descriptions of this Instrument are very rarely met with. The instrument is in use to some extent in the Indian Public Works Department, and will be found described in the Thomason C. E. College Manual of Surveying, but not in either of the large works on Indian Surveying (Smyth and Thuillier's 'Manual of Surveying for India,' and Sir A. Scott Waugh's 'Instructions for Topographical Surveying')—nor indeed (as far as the author could ascertain) in any work in the large Central Library at Roorkee.

The 'Adjustment' of the 'zero of altitude' described in the Thomason College Manual has the extraordinary defect (in both first and second editions) that it is directed to be effected by the use of the upper 'Level-screws,' although it is explained in the description of the Instrument (a few lines before), that this Level "is fixed by the maker, and does not admit of adjustment."

## No. CXXVI.

## THE AGRA CANAL.

[ *Vide* Plates LX. to LXX. ]

BY MAJOR H. HELSHAM JONES, R.E.

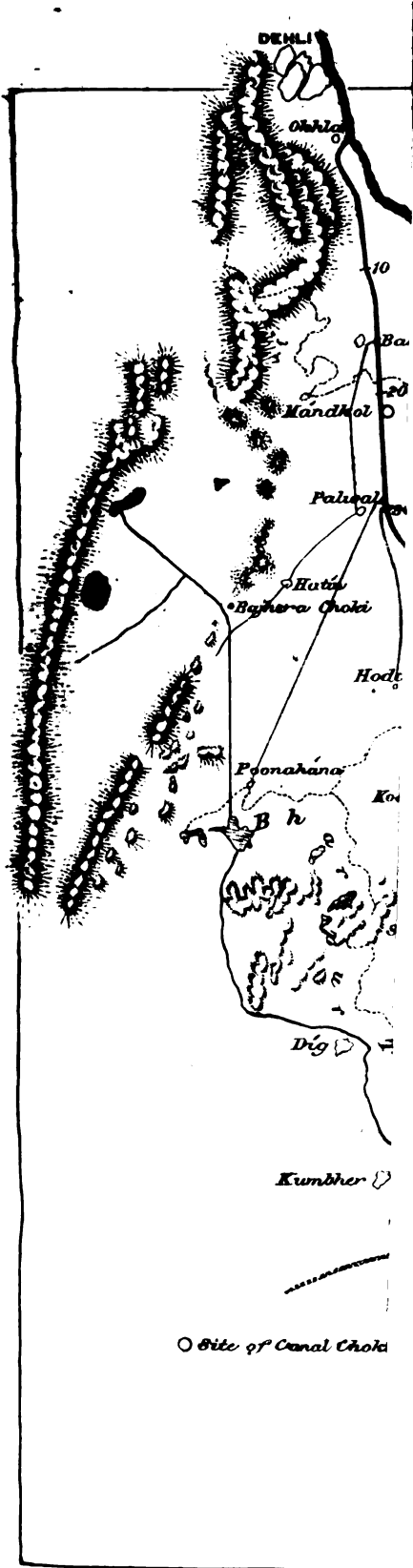
THE present paper does not profess to give a complete account of the Agra Canal, but rather a notice of the construction of the Head Works and some others with which the writer was connected while serving on the canal. It is written in the hope that the information may be useful to others engaged in similar works in organizing their own, and with this view many of the details of construction are given; and arrangements which were not successful are noticed as well as those which succeeded.

The Agra canal is intended to water part of the right bank of the Jumna below Delhi, and to form a navigable channel from Delhi to Mathra and Agra. The canal is also a link in the chain by which it is intended hereafter to connect the Panjáb system of canals with that of the N. W. Provinces. The surveys for the junction canal from the Western Jumna canal at Delhi to the Agra canal have been made, and the junction would be at Okhla.

The head of the canal is seven miles below Delhi, on the right bank of the Jumna, at the village of Okhla, and the canal is carried in a line parallel to the general direction of the Jumna passing Mathra about eight miles to the westward and Agra five miles; \* and, finally tails into the Utangan at 27 miles below Agra, and ten miles above the confluence of that river with the Jumna.

Navigation channels are provided to both these large towns.

\* The actual alignment passes within three miles of the cantonments.



THE present  
Agra Canal  
some other  
canal. It  
others engage  
view many  
which were

The Agra  
Jumna below  
and Agra.  
hereafter to  
Provinces.  
canal at Delhi  
be at Okhla

The head  
the Jumna  
parallel to  
miles to the  
Utangan  
that river  
Navigation

The total length of the canal is 140 miles, and its bottom width at the head is 70 feet, where its depth of water in the Rabi season will, with a full supply running, be seven feet. With a Kharif supply it would have a depth of 10 feet, making the surface width about 90 feet.

After leaving the river the canal line passes along the khadir for four miles to Ali, where it strikes into the high ground, but again emerges into the khadir a mile and half further down, quitting it finally at the seventh mile. The cutting is nowhere very heavy. The water reaches the surface of the country at about 20 miles from the head of the canal, and the first distributary is taken out at mile eighteen to water part of the Gurgáon District of the Panjáb. The other districts watered by the canal are the Mathra and Agra districts of the N. W. Provinces, besides which it is intended to give some water to the Native State of Bhartpúr.

The following Table shows the distribution of the water by Districts. The loss by absorption and percolation is estimated at 0·23 cubic foot per 100 cubic feet per mile of canal:—

District.	Irrigable area in square miles.	Percentage of land cultivated or culturable waste.	Percentage of land unculturable waste.	Percentage of land irrigated from wells.	Average depth of water in wells below surface.	Discharge allotted (in cubic feet per second).	
						Rabi.	Kharif.
Gurgáon, ..	311	93·1	6·9	6·7	48·8	236	373
Mathra, ..	347	90·3	9·7	11·4	48	271	440
Agra, ..	387	84·8	15·2	44·6	41·7	313	500
Bhartpúr, ..	154	..	..	..	..	115	180
Unapportioned, ..	..	..	..	..	..	..	227
Totals, ..						935	1,720
Estimated loss by absorption and evaporation, .. ..						165	,280
Grand Total, ..						1,100	2,000

The Agra district thus gets an excess of water taking its well irrigation (which of course it is by no means desirable the canal should extinguish) into account; but the navigation necessities require an undue quantity of water to be sent down, undue, that is, if the main object of the canal only were kept in view.

The discharges, as will be seen from the Table, are 1,100 cubic feet in the Rabi and 2,000 cubic feet in Kharif season. To increase the cold weather supply, the Hindan has also been laid under contribution. The discharge of the Jumna is liable to fall considerably below the necessary

quantity. Since the canal has been in course of construction it has in 1869-70, and again in 1871-72, fallen below 800 cubic feet per second. In May 1870, it had only 472 cubic feet, and in January 1871, but 756. The Hindan is generally capable of giving an additional 300 cubic feet, which added to the above would bring the supply up to 800 cubic feet as a minimum; this figure has been used in calculating the depths for navigation when laying out the lower parts of the canal.

The full Rabi discharges at different points of the canal are as follows:—

TABLE B.—Table of full Rabi Discharge and Distribution.

Canal mile.		Discharge of distributaries and loss.	Total deductions.	Mean velocity.	Discharge of canal.
	Canal head, .. .. .			2.04	1,100
	Palwal rajbuha, .. .. .	42			
	Loss by percolation, &c., .. .. .	43	85		1,015
30	Hatín, Hodal, and Hassanpur rajbuhas, .. .. .	194			
	Loss, .. .. .	30	224		791
32	Chajúnagar fall, .. .. .				787
39	Báta escape, .. .. .				775
49	Shergarh rajbuha, .. .. .	114			
	Loss, .. .. .	15	129		646
54	Loss, .. .. .	9			
	Kosi rajbuha, .. .. .	25	34		612
56	Loss, .. .. .	4			
	Sahár rajbuha, .. .. .	42	46		566
68	Loss, .. .. .	14			
	Bhartpúr rajbuha, .. .. .	140	154		412
77	Loss, .. .. .	7			
	Mathra navigation and rajbuha, and Aring rajbuha, .. .. .	65	72		340
85	Loss, .. .. .	5			
	Fatahpúr Sikri rajbuha, .. .. .	115			
	Farah rajbuha, .. .. .	25	145		195
91	Mallikpúr fall, .. .. .				192
100	Loss, .. .. .	4			
	Agra rajbuha, .. .. .	25	29		163
115	Loss, .. .. .	5			
	Expenditure from canal, .. .. .	56			
	Irádatnagar rajbuha, .. .. .	44	105		
	Leaves for irrigation to tail of canal,				58

The fall of the canal from the head to mile 32 is six inches per mile only. At this point it descends by an overfall of  $5\frac{3}{4}$  feet, and thence

the gradient is increased to 12 inches per mile, with which it continues as far as the eighty-sixth mile. From this point it has been found necessary, owing to the requirements of navigation, greatly to reduce the fall, making it only 4 inches per mile.

The velocities due to these conditions with Low Rabi, Full Rabi, and Kharif supplies, are shown in the following Table:—

TABLE C.—Discharge and Velocity of Canal.

Mileage.	Fall per mile.	Bottom width.	Depth.	Mean velocity.	Discharges.	
	feet.	feet.				
Head to 32	0.5	70	5.8	1.82	800 L. R.	With 800 cubic feet entering canal head, the rajbnhas are assumed to be running two-thirds of full supply only.
			7.2	2.00	1,100 R.	
			10.6	2.36	2,000 K.	
32 to 40	1.0	58.8	4.1	2.25	587 L. R.	
			5.0	2.46	787 R.	
			7.0	2.76	1,262 K.	
40 to 50	1.0	53.4	4.3	2.29	574 L. R.	
			5.2	2.5	769 R.	
			7.2	2.88	1,239 K.	
50 to 60	1.0	47.4	4.1	2.28	485 L. R.	
			5.0	2.46	642 R.	
			6.9	2.82	1,044 K.	
60 to 70	1.0	41.4	4.1	2.27	429 L. R.	
			5.0	2.44	563 R.	
			6.8	2.75	910 K.	
70 to 80	1.0	30	4.2	2.26	826 L. R.	
			5.0	2.38	414 R.	
			6.8	2.69	670 K.	
80 to 85½	1.0	24.2	4.4	2.20	276 L. R.	
			5.0	2.31	337 R.	
			6.6	2.62	535 K.	
85½ to 95½	0.83	24.2	4.9	1.24	176 L. R.	
			5.2	1.27	195 R.	
			7.0	1.41	309 K.	
95½ to 100	0.38	24.2	4.8	1.22	172 L. R.	
			5.1	1.27	191 R.	
			7.0	1.41	303 K.	
100 to 101½	1.0	21	3.8	2.06	188 F. R.	
			5.0	2.30	298 K.	
101½ to 109	1.0	18	3.7	1.97	160 F. R.	
			4.9	2.23	250 K.	
109 to 117	0.58	18	4.0	1.51	132 F. R.	
			5.2	1.68	203 K.	

The Agra Navigation takes off here.

Below mile 117 the canal has only the functions of a distributary.



These velocities are very much below those of the older canals, where so much damage has been caused by the erosion of the bed and banks and consequent perturbations of the current. In seeking to prevent this it is evident that there is a danger, indeed it may be looked for as certain, that the opposite evil of silting up will have to be met. This it is proposed to do by dredging, and by the use of a scouring escape placed a mile-and-a-half below the canal head, at Jasaula.

The silt-charged water will, it is evident, deposit largely in the entrance of the canal, and the fact of this being on a curve will increase the tendency to silting. Thus it is expected that a great part of the silt will be deposited in the first reach of the canal, in which dredgers will be used to remove it, and that the water will pass on *comparatively* pure. Silt must, however, be expected lower down also, and it remains for experience to show whether the reduction of gradient has, or has not, been too great.

The head works of the canal, which it is more particularly the object of this Paper to describe, are situated (as above-mentioned) at Okhla, seven miles below the E. I. Railway bridge at Delhi. They consist of a weir extending across the stream, and supported on the left bank by a wing-wall on deep foundations, and an embankment which is carried from thence up to the Delhi Railway bridge. On the right bank the weir abuts on a spur of the rocky line of hills which extends out of Central India as far as Delhi. The weir is thus perfectly secured on this right flank; and, moreover, the rock furnishes the material which has rendered it possible to form the weir in the way presently to be described.

The head works consist of—

The left wing wall;

The weir proper, or waste weir to pass flood waters;

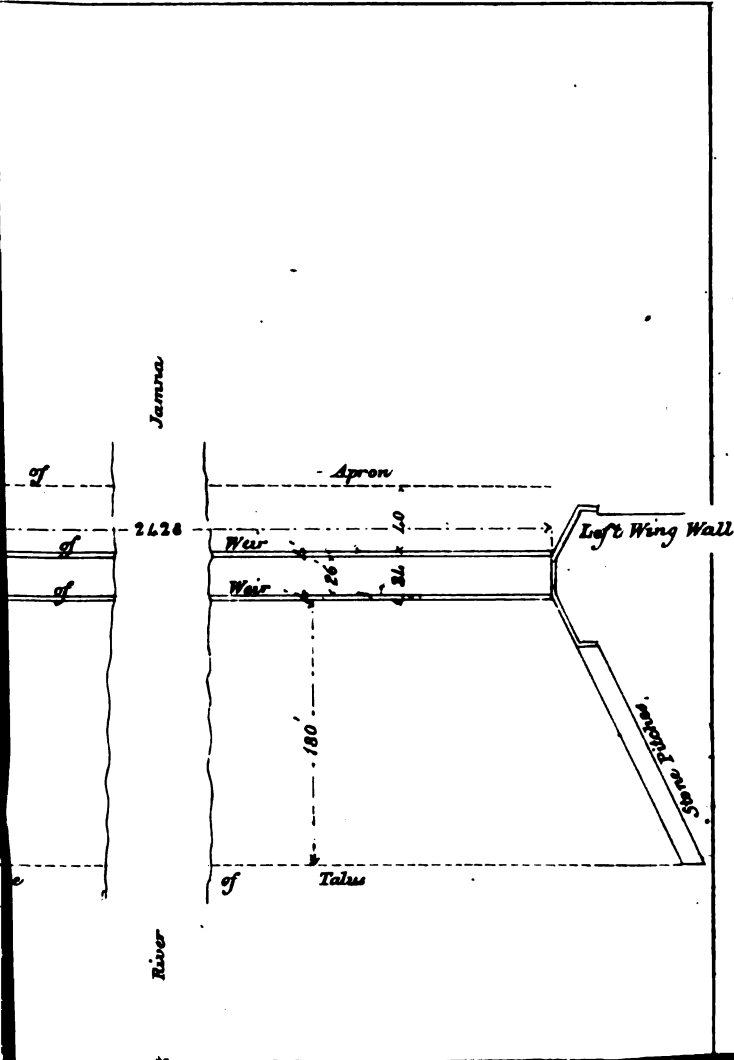
The undersluices on the right flank of the weir, which are intended to pass off an ordinary cold weather supply when the canal does not want it, as well as to perform the important function of scouring away deposits in front of the entrance to the canal;

The canal head, the face line of which forms a right angle with the direction of the weir crest line; and

The lock, the axis of which forms an angle of 55° with the face of the canal head, (*see* General Plan, *Plate LXI.*)

Proceeding in our description from the left or east side, we have first

PLATE LXI.



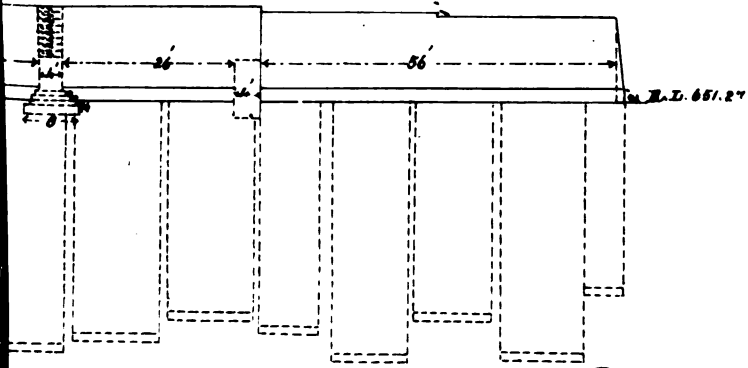
611.36    614.65    619.96    611.36    611.5



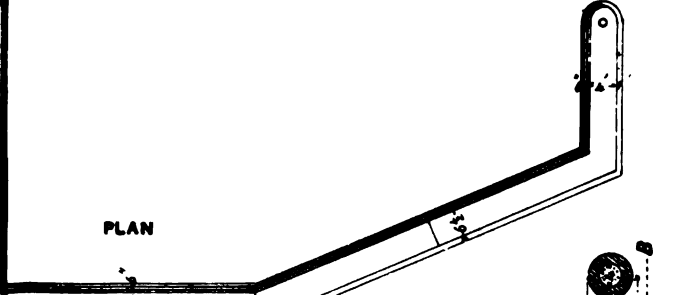


Igra Canal.

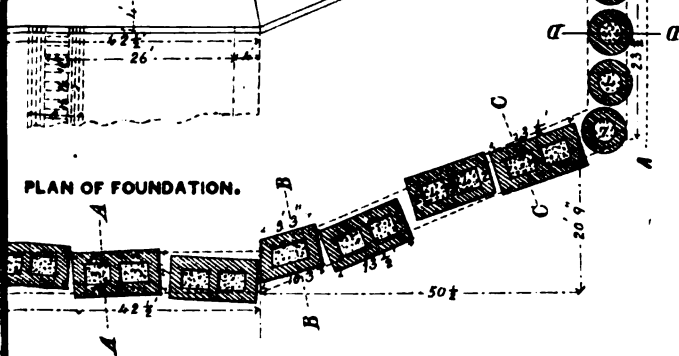
Elevation



PLAN

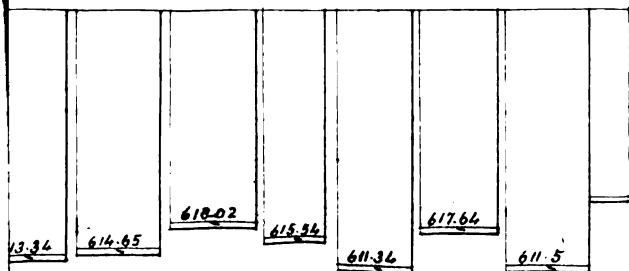


PLAN OF FOUNDATION.



Elevation of Block Foundations

R.L. 661.27





the left wing wall. This is founded upon blocks 13' 6" long by 9' wide, which have in each of them two well-holes 4 feet by 3. The design of these blocks is like that of those used by Sir P. Cautley at the Solani aqueduct and elsewhere. They were built on kerbs with a broad seat and no cutting edge. The task of sinking them to an average depth of 36 feet was therefore rather a difficult one. They, most of them, reached a bed of kankar. The deeper sinking was done with the sand pump, which proved very useful when the native *jhám* failed. The pumps used were 2 feet in diameter, and were lifted by crabs.

A return wall on the down-stream side, which was added to the original design, stands on four circular wells of 7½ feet diameter, and these being built on kerbs made with a bevel, were sunk without any difficulty to the kankar bed. One of these was left without hearting and, a shaft being brought up over it in the thickness of the wall, is used as a draw-well and found very useful. The superstructure, like the rest of the Okhla works, is of coursed rubble stone with large bond stones of undressed ashlar, and a coping of dressed ashlar. The ashlar was got from Molarban, 4 miles below Okhla, on the canal, and the rubble picked out of the stone quarried at Okhla for the weir, and dressed partly by hammer and partly with the chisel.

The undersluices are on the right flank of the weir, and are 138½ feet in width between the abutments. They contain sixteen vents of 6 feet each, separated by piers 2 feet 10 inches in thickness. They are divided from the weir by a wall 6½ feet thick, which forms their left abutment, and supported on the right by a abutment wall of similar thickness.

The floor of the work is at R.L. 648, while the crest of the weir (when finished) will be at 659. Consequently, the sluices can carry off about 10,000 cubic feet per second before the crest of the weir is covered, supposing the water below to stand at about 650. The undersluices are founded on four lines of blocks similar to those of the left wing. These four lines enclose the area of the foundations forming a large cofferdam. After they had been sunk and hearted with concrete, their intervals were filled up by double piling with concrete between.

This having been done, a 9-inch Gwynne pump worked by a 10-horse engine was fixed on the west side of the blocks and, the sand from inside having been removed to a depth of 6 feet, a floor consisting of 2 feet of

dry rubble stone, 3 feet of rubble masonry and 1 foot of ashlar was laid over the whole area.

In the up-stream portion, which has to carry the superstructure, the 2 feet of dry stone were omitted and replaced by rubble masonry, making the masonry floor for that part 6 feet thick.

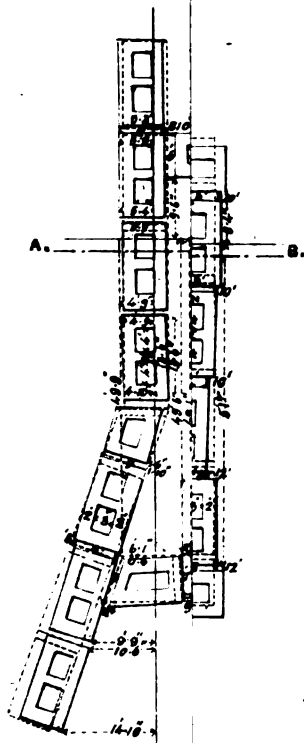
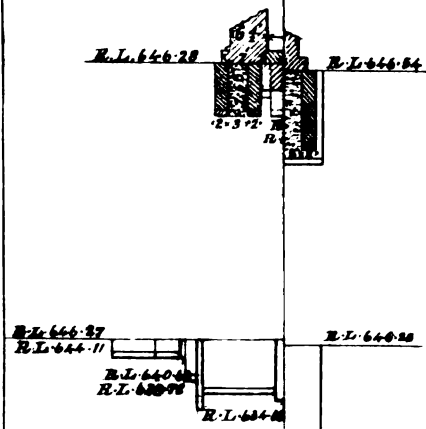
The piers are of rubble masonry with frequent large bondstones. The whole of this work leaked a good deal when exposed to a head of pressure during the floods of the first season (1870). This was due partly to the porous nature of the kankar lime mortar, and also partly to the unavoidable imperfections in this class of work when built with stone so irregular in shape as the Delhi quartzite. The leakage was stopped by pointing the work in the ensuing cold season with Portland cement. It would have been a good plan to have laid the facestones in cement.

The total height of the work above the floor is 19 feet, and a maximum flood may be expected to stand 17 feet deep on the floor, or 7 feet above the springing of the arches. In 1871 it rose to nearly 16 feet. To prevent the spandril walls from leaking, a backing of good concrete 3 feet thick was added in 1870-71, (*see Plate LXIV.*) It would however have been preferable to have sprung the arches at a higher level so as to have as much clear waterway available as possible, and in that case, there would have been no spandril walls to leak. The vents it is proposed to close by wrought-iron gates.

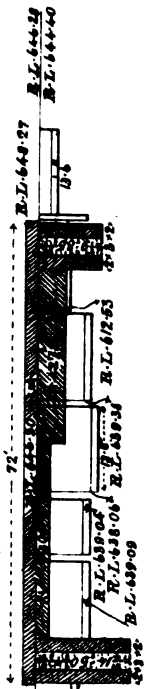
*Canal Head.*—The face line of the canal head is at right angles to the crest line of the weir and the centre line of the head cuts it at 118 feet above the weir crest. The canal head consists of twelve openings of 6 feet each, their arches being sprung at the level of full Kharif supply in the canal, or 10 feet above the floor of the head. The piers of both canal head and undersluices were designed 3 feet thick, but those of the sluices were reduced to 2 feet 10 inches in construction to make up for a loss of length in the foundation due to irregular sinking of the blocks. This was a change in the right direction, but not to a sufficient extent; the piers are still too thick for the openings and cause a great deal of heading up and consequent loss of waterway. They might easily, with proper precautions, have been built 2 feet thick only, or less if ashlar had been used.

In construction the canal head is similar to the undersluices, except that the floor level is 4 feet higher than that of the sluices, and the height of the terreplein is thus 15 feet only instead of 19 above the floor.

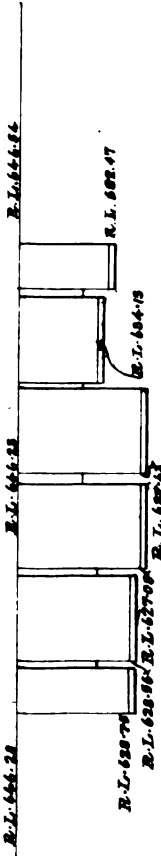
Igra Canal.



SECTION ON C.D.



END ELEVATION OF BLOCKS

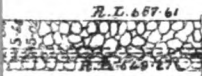
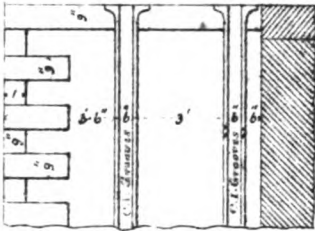






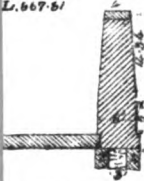
# Canal.

ENLARGED PLAN OF PIER HEADS.

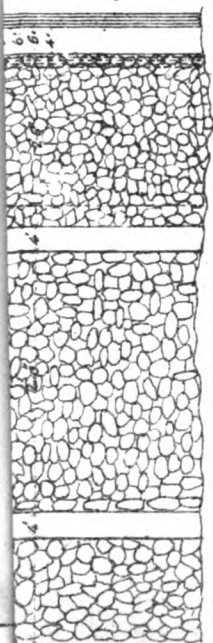
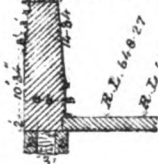


SECTION ON A.A. SECTION ON B.B.

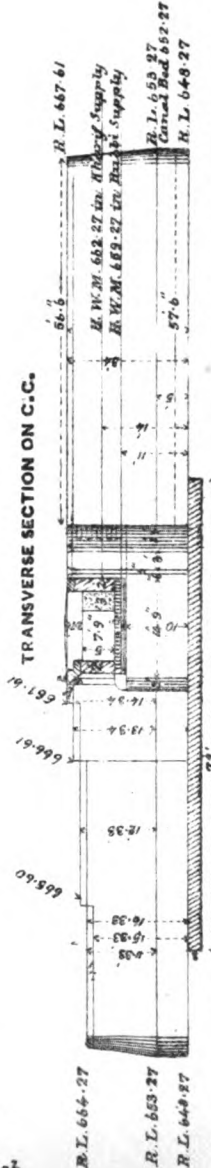
L. 667-61



R.L. 667-61



TRANSVERSE SECTION ON C.C.

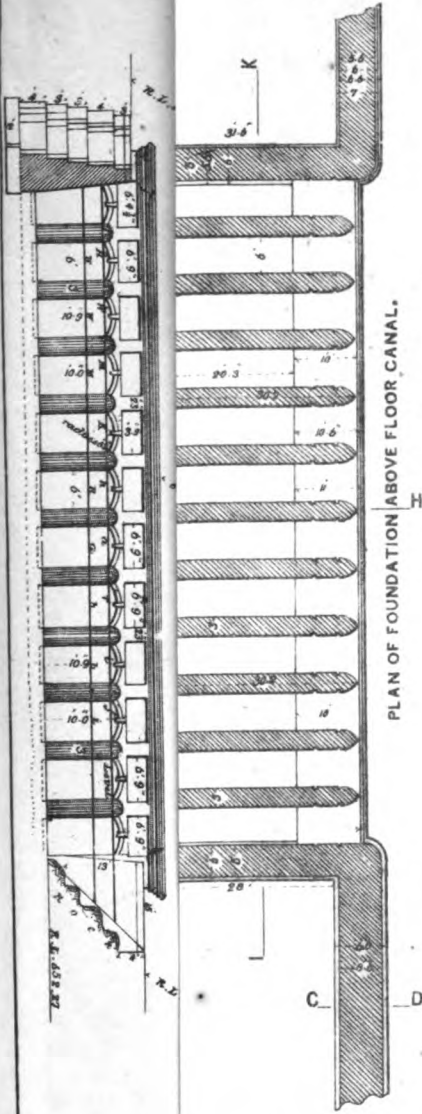


Scale, 6 feet, to an inch

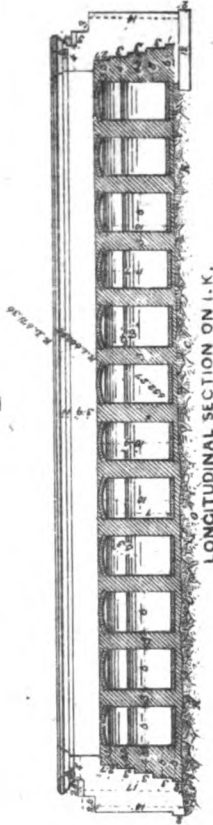




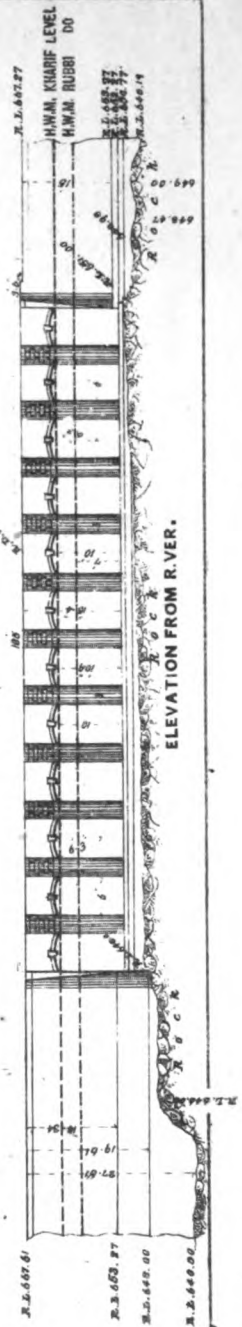
nal.



PLAN OF FOUNDATION ABOVE FLOOR CANAL.



LONGITUDINAL SECTION ON I. K.

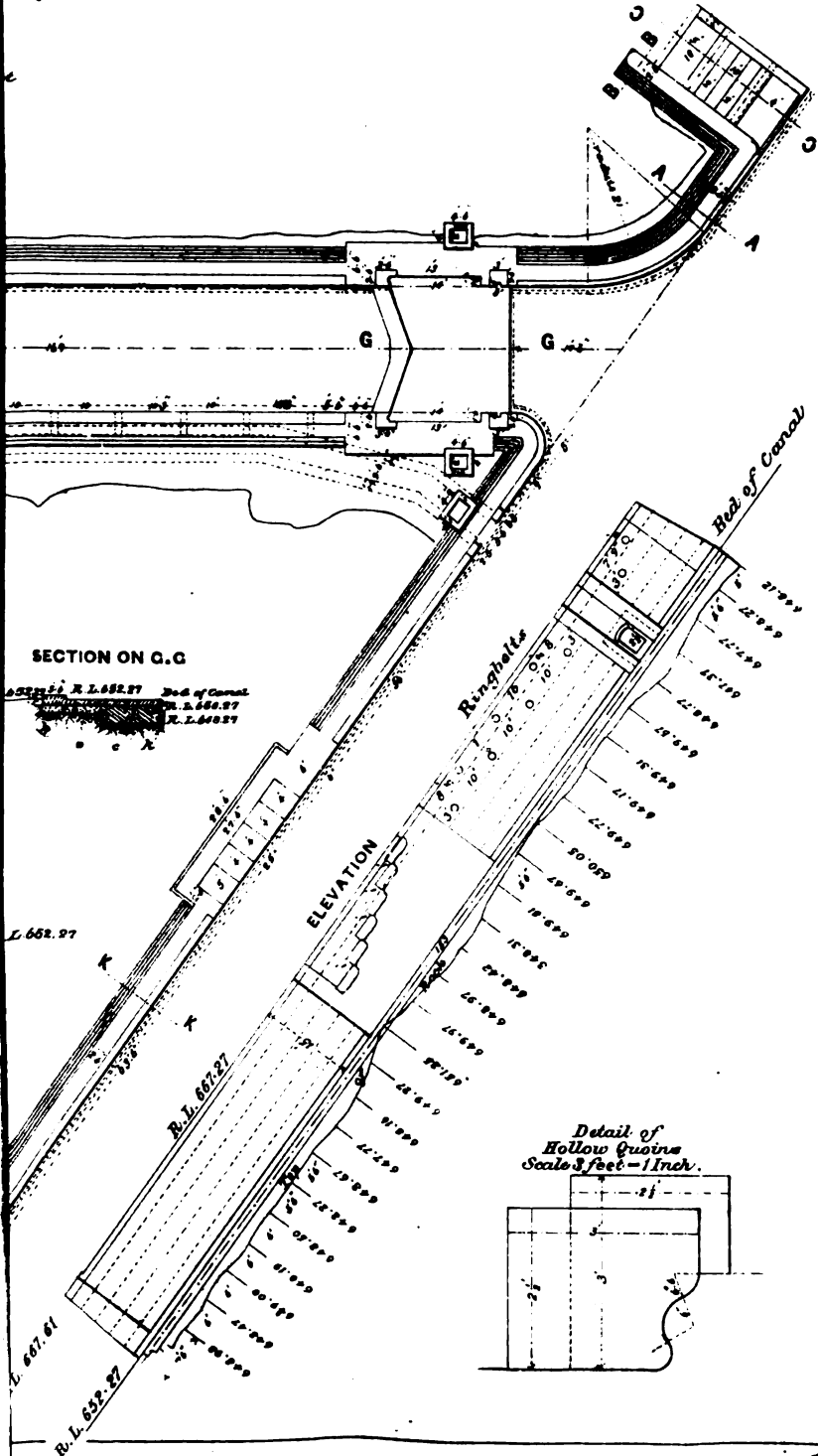


ELEVATION FROM R. VER.





Canal.





The width of the work between abutments is 105 feet. The length of the ashlar floor, taken in the direction of the current, is 30 feet only. The foundation of this work, as well as of the lock and of the river wall which connects the two, is partly on rock partly on gravel.

The lock entrance is 340½ feet up-stream of the weir crest line, and the axis of the lock is on the skew, making an angle of 55° with the face line of the canal head. The lock channel joins the canal at 387·9 feet from the entrance of the lock. The up-stream side of the lock entrance is finished off by a short retaining wall ending in a flight of steps; and an embankment faced with stone carried a short distance up-stream, in a direction somewhat falling back behind the prolongation of the face line of head, completes the river front.

The lock chamber is 120 feet long by 20 feet wide at bottom, and 23 at top. Its depth is 15 feet. Its only peculiarity is the mode of filling and emptying. This instead of being done by sluices in the gates, or by a culvert round behind the hollow quoins, is by means of a long culvert, which opens at its upper end into the river about 30 feet below the centre of the lock entrance, and from thence runs along the left chamber wall and issues in the tail bay. It is closed by a sluice gate at each end, and communicates with the lock by 16 circular barrels through the chamber wall. The operation of passing a boat will thus be effected by the action of only two sluices, the 16 openings serving as inlets and outlets as the lock is being filled or emptied. The lock will of course only be required to work when the river level is higher than the supply level required; at other times it will stand open. As the river level can be regulated within considerable limits by working the undersluices, the action of the lock will probably be confined to times of actual flood in the Jumna.

Having thus briefly described the subsidiary works, we come to the weir proper, before proceeding to describe which it may be useful to register the principal levels of the works. They are referred to the G. T. S. datum, viz., mean sea at Karachi. Omitting, for convenience, an unimportant decimal, they are—

Floor of canal head,	..	..	..	..	652
” ” undersluices,	..	..	..	..	648
Crest of weir,	..	..	..	..	659
Foundation level of weir,	..	..	..	..	649
Level of top of works,	..	..	..	..	667
Old level of water surface of the Jumna in cold season,	..	..	..	..	649



Old level of bed of the Jumna in cold season, ..	646	
Highest flood level observed on weir, ..	664½	} with weir one foot short of full height, in 1871-72.
"    "    "    below weir, ..	661	
Probable maximum flood (with 10 foot weir), ..	666	

The width of the weir between abutments is 2,428 feet, and in section it consists of—

- (a). A front wall, 10 feet high and 4 feet thick.
- (b). A second wall, 9 feet high and 4 thick, with its crest 30 feet below the crest of the upper wall.

Between these two walls the space is packed with stone.

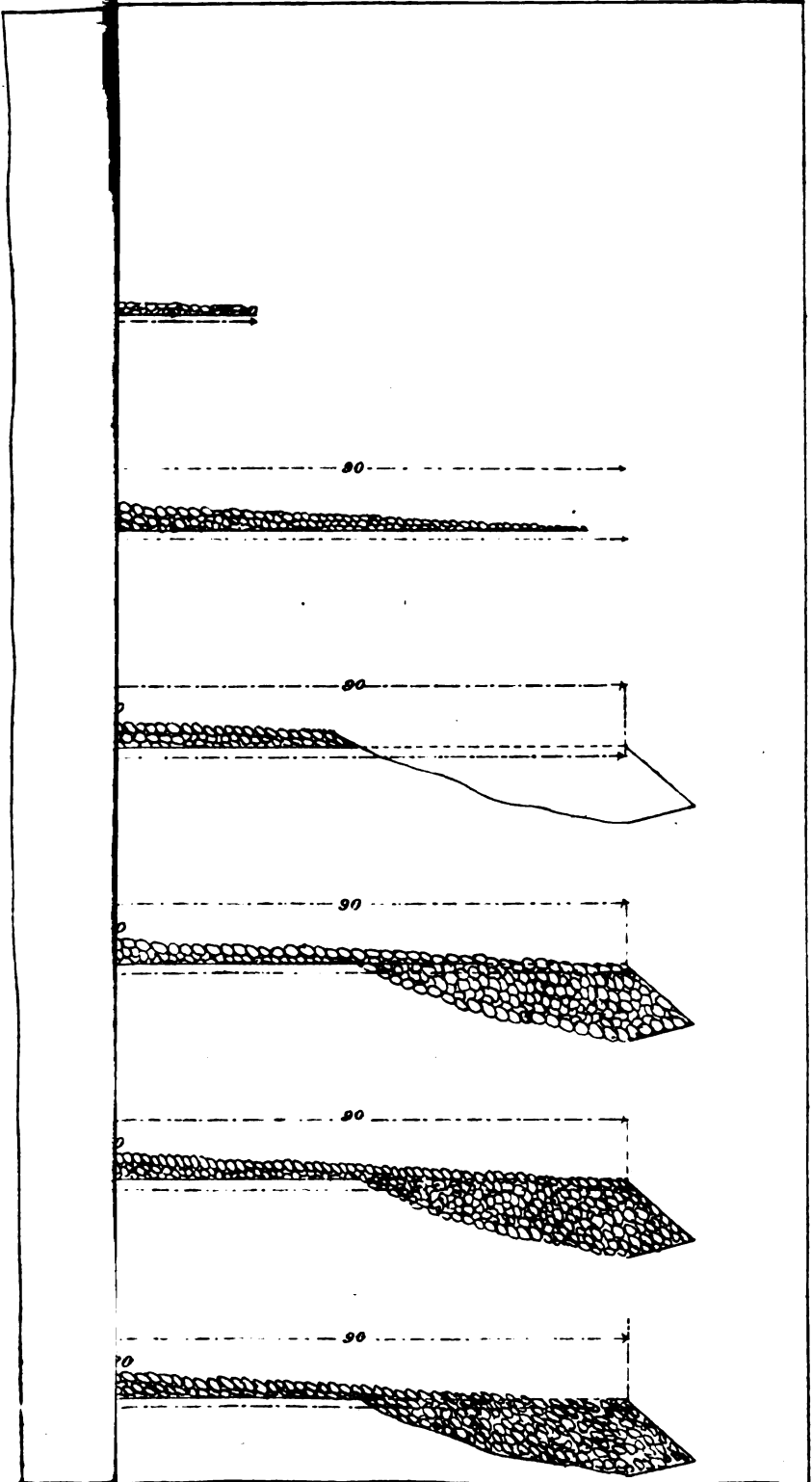
- (c). An apron 40 feet long in front, or up-stream, of the first wall with a slope of  $\frac{1}{4}$ .
- (d). A talus 180 feet long below the second wall, with a surface slope of  $\frac{1}{2}$ . This talus it was originally intended to make 90 feet longer, but it has not yet been extended to that length, and it seems likely that there will be no need ever to add to its present length.

Besides these a third wall, extending 3 feet down from the surface has been added to the original design, as will be described further on.

The large mass of stone required for this work has been quarried close by, the furthest point of the quarries being only  $1\frac{1}{4}$  miles from the right flank of the weir. The stone is termed quartzite. It contains a large proportion of quartz, a little felspar, and protoxide of iron. The last gives the stone when freshly quarried a greenish blue color, which it speedily loses under the action of the atmosphere on the iron, and then assumes a rusty hue.

Ultimately (in the course of ages) the action of the iron appears to lead to the decomposition of the stone into a sharp red gravel (locally called *bajri*), and in this form it is found in the quarries mixed up with good stone. It is not difficult to find in the quarries masses of stone the outside of which is quite decomposed, while the heart is sound. Before becoming gravel the stone of course passes through all the intermediate stages, and the "red stone" was found very useful in the construction of the weir when mixed in due proportion with the blue, as it broke up when thrown in and formed a good packing.

The stone comes out in pieces of very irregular shape, the quarries near Okhla yielding scarcely any bedded stone though parts of the same





range of hills contain quarries from which stone with a natural bed can be obtained. This is due to joints, not to any stratification properly so called. It is not an uncommon error to believe that sandstone is found near Delhi, but that is not the case. Stone of large size can be got out at Okhla, though of awkward shape, and such stones were used in covering the slope of the talus—some of them weighing as much as five tons.

These stones were dragged by crabs and chains out of the quarries and put into the trucks, either by hoisting them with Weston's patent blocks or from inclined planes, which brought them up to the level of the truck floor. Quarrying "blue stone" cost at first as much as Rs. 4-4 per 100 cubic feet. It was afterwards reduced to Rs. 3 and Rs. 2-4.

It was impossible to get the natives to quarry properly, as they will put their blasts in vertically irrespective of the planes of cleavage. On such work it would certainly pay to have some good European quarrymen to *make* the natives work properly.

Rails\* were laid in various directions in the quarries, and were shifted as occasion required so as to keep them close to the quarry work. In the first two seasons (1869-70 and 1870-71) there were two lines of way on the weir, since that one only carried on a staging close to the weir wall. The stone was conveyed in trucks holding a little over 30 cubic feet. They are on cast-iron wheels 2 feet in diameter, and the truck is  $5\frac{1}{2}' \times 5'$  and 9" deep. The floors are of sál plank on a sál frame and the sides were bolted on and were removed when the trucks were used for large stone. Each truck was loaded, pushed, and unloaded by the same gang of four men, who were paid by the trip, and the wagons were run in "rakes" of 25 to 40 and more trucks, two such rakes being worked together, one loading up at the quarries while the other was unloading on the weir. This was when there was only one line to unload on. When two were available, a smaller number of wagons and more trips were worked, which is a better arrangement. The greatest number of wagons running at once was 120, in 1871. The wear and tear of wagons was considerable owing to the nature of the stone, and about ten per cent. were generally under repair. The wheels wore down very fast owing to the sharp gravel which was constantly blown on the rails. The wheels used were of ordinary cast-iron, but would have been better "chilled." The tyres were made thick enough to allow of turning up

\* The rails at first laid down were those used on the Soláni embankment of the Ganges Canal. Others were afterwards added, making a length of about  $4\frac{1}{2}$  miles.

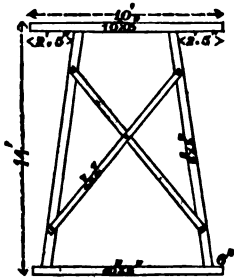
when they were worn. The gauge is 4 feet  $8\frac{1}{2}$  inches, the common narrow gauge, which is very convenient for hand shunting, more so than the narrower gauge now in fashion.

Work on the weir was begun in the latter part of the cold season of 1868-69. A large quantity of stone was thrown in from the right bank of the river to form an embankment, and a spur was run out in order to set the flood stream over and made it scour away the left bank. It should be explained here that, previously to the work being begun, the flood discharge passed in two channels, one about 1,300 feet wide on the right or west bank, and the other, called the eastern channel, about 600 feet, separated from the first by an island about 1,500 feet wide, (*see Plate LXVIII.*) The bifurcation of the channels was about three-quarters of a mile above the weir. The first operation was to close this eastern channel, which was done by means of a bund 20 feet wide at top, resting on the island, and with its left, or eastern, flank supported by the longitudinal embankment before-mentioned, which runs up the left bank of the river to the east abutment of the Delhi railway bridge, seven miles above Okhla. As the weir was to occupy the whole of the western channel, and upwards of 1000 feet of the island, it was evidently desirable to remove as much as possible of the latter by means of the action of the river, and hence the reason for the stone spur. This spur was carried out by a staging on screw piles into deep water, and then large stones thrown in below and on both sides of the staging. The total quantity of stone put in during the season of 1868-69 was 352,000 cubic feet. All this was below the line of the weir, however, with the exception of a part near the undersluices.

The original plan was to form the weir from each flank towards the centre, until only a gap large enough to pass the cold season supply was left, and then to close this first of all by a curved bund of stone thrown in below, or on the down-stream side of the gap. During this operation, and the subsequent building of the wall across the gap, the water was to have been passed through the undersluices, which it was hoped would have been ready in time. In 1869-70 the programme of the season's work was to build the superstructure of weir sluices, the blocks of which had been sunk in 1868, and to carry the second or down-stream wall of the weir right across the river with a talus 120 feet wide, and an apron of 20 feet to protect it. The wall was not to be raised to its full height but only to a height of 5 feet.

The actual formation of the weir began in December 69. The sand was removed to the level of 649, and at this level the stone was laid, being the same as that at which the foundation of the weir walls is laid. The walls are, as will be seen from the section in *Plate LXVII.*, simply built upon the sand of the river bed. In December a cut was made from the left wing in the direction of the end of the stone spur, and the tramway was continued along it crossing the stream on screw piles. This cut was filled with stone, and was the first part of the actual talus laid. The triangular space between it and the wall was next excavated and filled with stone. Meanwhile the wall had been built from each flank down to the waters' edge, and the formation of the weir on the western side pushed on. During this time the stone was brought down by the original tramway. In January 1870, a new staging was put up in order to command better the upper and deeper part of the work, and also to keep up communication during floods, and meet the Chief Engineer's order to put in stone where depressions occurred under the action of the water.

This staging was constructed in a straight line from flank to flank of the weir, at a distance of 16 feet from the wall which then formed the crest. It was carried across the cold weather stream (then only 330 feet wide) on screw piles protected from scour by stone. On the remaining length the line was carried on trestles, the construction of which is shown



Head and sill of chr.  
Legs and braces of sal.

by the sketch. The sill is a plank about 10 inches wide which was laid on the sand, and under this were laid 3 other planks with their lengths at right angles to it, in order to distribute the pressure. These trestles are at 14 feet central interval and were all set up on the sand at formation level of the weir before the section was formed. The stone was then put in and protected the sand under them from erosion, and thus no settlement has ever occurred. During the first season there were 4 feet of stone over the feet of the

trestles, which was increased by the raising of the weir in 1870-71 to 8

feet. This staging is still standing, and has never given any trouble at all. It was raised 3 feet in 1870-71, when the weir was raised, by bolting on short pieces of timber to the legs of the trestles.

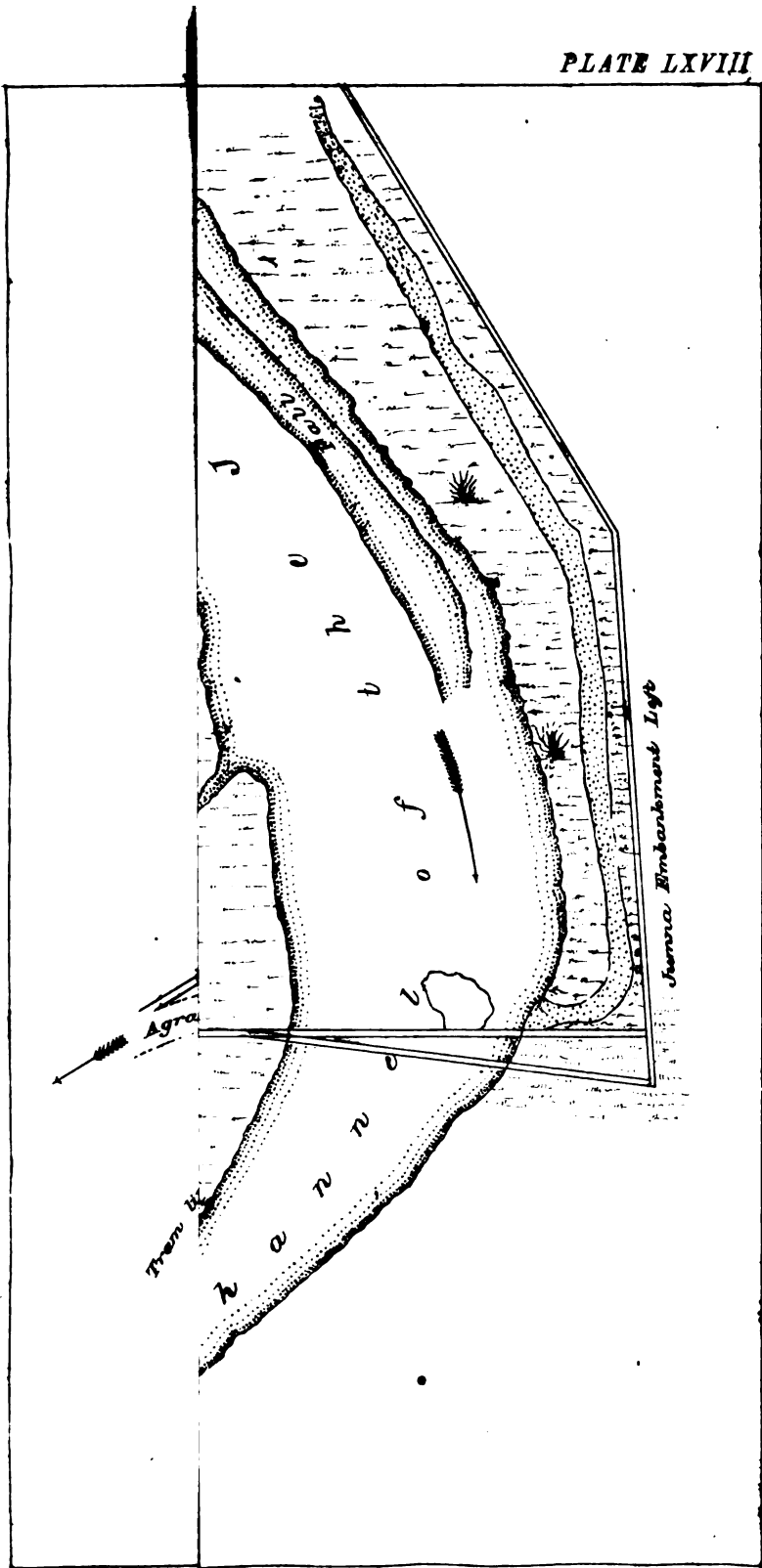
At the end of February 1870, it became necessary to close the gap in the weir in order to secure the work in good time against a possible early flood but, owing to delays caused by the cut stone work, the undersluices were not ready to be opened; and, therefore, it was necessary to close the gap in spite of the stream running through it. Fortunately the season was one of unusually low supply, and the operation was thereby greatly favored. The original plan of closing on a line below the weir was now abandoned as the staging gave the power of pouring stone in rapidly on the line of the weir itself. The bed of the stream was first of all carefully covered all across with stone to prevent unequal scour, and then the gap was closed completely by rapidly throwing in stone, taking care that the whole was evenly and regularly brought up. In this way the gap was closed between the 1st and 15th March, and the water rose for the first time to the (then) crest of the weir on the 24th. The section of the stream was 330 feet in width and two to three feet deep.

The wall was not then continued across as it was not immediately necessary, and it was thought better to leave the stone to settle till the next season. When the stone was afterwards taken out to get in the wall its interstices were found completely closed by the sand and silt which had percolated into them during the flood.

The ashlar floor of the undersluices was finished on the 27th April, and, the superstructure being well advanced, water was passed through for the first time on the 29th.

Meanwhile the canal head was also in progress; the floor was finished early in May, and the superstructure during the hot weather. The lock and river wall had not then been begun, only the excavation was in progress. That for the river wall was very tedious being in hard rock. There was also a large mass of rock to be removed in front of the works at this part, to give the river a clean sweep past them as well as to open an entrance to the lock.

The access to the weir was of course obstructed for the floods by the island before-mentioned which still extended about 800 feet from the left wing. To get rid of this, four cuts each 50 feet wide were made from a







point in the island 2,000 feet up-stream of the weir\*. These conducted the water to it, and corresponding cuts were made on the down-stream side, two of which turning to the left discharged into the lower part of the old eastern channel and the other two to the right into the western, or main, channel. These cuts answered their object, they deepened and widened rapidly during the floods (the widening being accelerated by putting men on to loosen the edges) and the intervening patches of the island have now almost entirely disappeared, leaving the weir unobstructed.

The floods of 1870 were not heavy. The first did not come down till the 1st July, the highest was on the 5th September. After the subsidence of the flood, it was found that large holes had been scoured out at the lower edge of the talus, some of them as deep as 18 and 20 feet below the formation level (649). The stone, however, on the surface of the slope had not been much disturbed, though only stones of moderate size had been used. The weir being at this time only 5 feet high, the afflux was trifling. The highest flood reading, 659·65 or 5·38 feet deep on the crest, while the corresponding down-stream gauge reading was 659·30, showing an afflux of only 0·35 feet.

*Season of 1870-71.*—In the working season of 1870-71 orders were received to raise the weir from 5 to 9 feet, the full height of the second wall, and to begin the upper or front walls. Some fears had been felt of unequal settlements causing cracks in this long wall (2,430 feet in length) but none could be detected. In building the front wall the footings were spread so as to keep the pressure on the sand with the wall 10 feet high, at the same amount as that of the second wall when 5 feet high. The front wall, like the other, was built simply on the sand. The extension of the weir talus to 180 feet in length from the second, or lower wall, was ordered, and the apron to be continued in front of the upper wall far enough to protect it from scour.

The talus, sloping  $\frac{1}{20}$ , was thus brought level with the top of the second wall, now 9 feet high, and the apron sloped to the front from the same level. The first 90 feet of talus from the crest downwards were to be pitched with very large stone.

This was all done with the exception of part of the apron which (unfortunately as will be seen) could not be completed. The large holes above-mentioned were first filled with sand to formation level, and then

\* See Plate No. LXVIII.

the new part of the talus was formed, and its surface laid with stone very carefully packed on end, *i. e.*, with the longest dimension vertical.

A pile bridge was got across the stream issuing from the undersluices, and a line laid over it and along the lower part of the talus to relieve the pressure of work on the upper staging and to reduce the lead of the stone into the work. This line was shifted and sidings laid in as occasion required. The large stone packing of the upper part of the surface was all hauled into position by crabs and chains and packed close, being set as far as possible on edge. As these stones run from one to five tons, this was a laborious operation. The quantity of stone put into the weir was 9,50,000 cubic feet. The footings of the front wall were built for the whole length to an average height of about  $2\frac{1}{2}$  feet. The second wall was finished, the large rough ashlar coping being lifted and relaid. The left wing-wall was completed, and late in the season orders were received to begin the lock and river wall. The lock entrance was brought above flood level of the river, and about two-thirds of the foundations were got in before the water rose too high for work. A light iron staging was thrown out from the main staging at 1,000 feet from the undersluices, extending 80 feet above the crest of the weir, from which to observe velocities and find flood discharges.

The floods of 1871 were the most severe which had been known within a generation at least, and were unusually prolonged. The first heavy flood occurred on the 24th June, and they continued to increase in intensity up to the 14th August, far exceeding in volume what the observations of previous seasons had indicated.

The flood of 24th June caused a breach in the left embankment about half a mile up-stream of the weir, at a point where it crossed the line of an old channel. The bank was not overtopped, and the failure must have been caused either by the old channel forming a weak place or by some hole made by vermin through which the water found its way. The breach was closed after a good deal of trouble on 5th July, by using a number of rough gates made of planks spiked together, which were floated unto the breach, then about 70 feet wide, and pressed down simultaneously so as to rest against a line of piles; fascines and earth were then thrown in front of them. One or two were carried away leaving a narrow gap which was closed by stone and earth.

The river, however, continued to rise, and it soon become clear that the

embankment was likely to be overtopped. Efforts were made to increase its height, but the flood water passing through a gap in the embankment near Delhi left, for the tail of the Eastern Jumna Canal, flooded the land behind the embankment, and rendered it impossible to obtain sufficient earth to add to the height more than a very narrow bank. This eventually gave way, and between the 31st July and 12th August the embankment was breached in not less than twenty different points in the first two miles above the weir; and, in fact, may be said to have been destroyed for that distance.

Several of the neighbouring villages were surrounded by water and crops were destroyed, but ultimately the flood proved beneficial to them, as the villagers were enabled to grow such a Rabi crop as they never had before, and in many cases to grow grain where they had nothing but coarse grass in previous years.

The most dangerous of these breaches was one which occurred only 600 feet only up-stream of the weir. In the case of the other breaches, the water spread over the country, and found its way by long and easy descents back into the Jumna or into the Hindan. This one was so close to the weir that there was a heavy fall through it, and the water ran round the angle of the embankments into the old eastern channel below the bund which closed it. Great retrogression of levels ensued, and the lateral scour threatened the bund. A number of stone spurs had to be used, and the breach itself was closed by a mass of stone. The weir staging and tramway admitted of stone being brought rapidly to the spot.

The eastern channel bund itself gave great anxiety. The toe of its down-stream slope became like quicksand and sand bags, filled with clay and gravel brought over from Okhla and put in on the up-stream side, had to be used to strengthen it.

The action on the weir was very considerable. Stone was washed out of the surface on the upper part and deep holes, some as much as 20 feet below formation level, were scoured out on the down-stream edge, the section of the talus being reduced on an average 26 feet in length; in some places as much as 40 feet was carried away.

The greatest depth of flood on the weir crest was 4.55 feet, with a mean velocity on the crest of 9.33 feet per second. The weir was then "drowned" 2.58 feet. The greatest velocity on the talus was 18.26 feet per second, and was found at 42 feet below the crest.

Observations were made on the weir crest with current meters to ascertain the co-efficient for reducing surface to mean velocity of the film passing over. The observations were taken at all depths, and the co-efficient deduced was 0.97.

The greatest discharge measured over the weir was 103,068 cubic feet, but the discharge of the river on the same day was calculated at not less than 150,000 the undersluices passing 6,500 cubic feet and the breaches in the left embankment 40,300, calculated from sections of them which were taken at the time by allowing a very moderate mean velocity through them.

The action of the water passing through the undersluices cut away a large bay on the right flank, and also undermined and brought down part of the weir on its left, showing the necessity for a longer abutment wall to the undersluices. When the river fell, a good deal of the unfinished front wall was found to have been undermined and upset by the scour (caused by the undersluices being opened during the floods) along the apron from left to right. This would not have occurred had the apron been complete.

In the working season of 1871-72, the left embankment was repaired, and two miles of it re-aligned cutting off an angle and withdrawing it more from the direct action of the stream and upon better ground. The section was also increased. The eastern channel bund was also strengthened and straightened, its front slope being made  $\frac{1}{4}$  and rear  $\frac{1}{2}$ , with a top width of 20 feet.

The holes below the talus of the weir were filled up with stone. A little less than a million cubic feet of stone were expended in this way, and the effect has been that in 1872 and 1873 the talus has remained nearly intact so far as this class of damage goes, though it suffered in 1872 on the surface. The talus of the undersluices had been very much washed out by the action through them, and when it became possible to sound the wells were found to have been exposed to 18 feet, nearly their full depth. This was remedied by putting in large stone from a floating bridge with a narrow gauge tramway for stone trucks laid upon it, by which means very large stone was got in. The lock and river wall were finished during this working season. The front wall of the weir was brought up in part to the same level as the second wall, leaving only the work of setting the coping to be done. It was not necessary or desirable to increase the height of the weir at present. The interval between the walls was filled

with stone and some larger stone placed on the surface. A winter flood in the beginning of February, after high gauge readings in January, seriously retarded the progress of the front wall, rendering the repair of the damage done by the floods tedious and difficult, and a good deal of the wall was necessarily left below the full height.

The velocity staging was shifted to the centre of the weir and extended to 84 feet up-stream. Two other small platforms were also made to take velocities over the weir crest, and at each of these three points an iron gauge with a knife edge up-stream was fixed, in order to read actual depths on the crest.

The floods of 1872, though not so constant as those of the previous year, rose higher on the weir. The greatest depth on the weir crest was 5·08 feet, with a mean velocity of 10·42 feet per second, and 6·9 feet velocity of approach. The discharge was calculated at 128,500 cubic feet. In the previous year it was 103,000 cubic feet over the weir, but the total discharge, as has been given above, was greater by some 22,000 cubic feet.

Were the whole of a discharge of 150,000 cubic feet to pass over the weir when completed, it would have a depth of over 6 feet on the crest, and the action on the slope would be very severe indeed. In 1872 a great deal of the heavy stone pitching was removed and carried down the slope, where it collected in large masses, causing eddies which had the appearance of being very deep holes when seen from the staging, and it was impossible to get nearer as nothing short of a life boat could have lived in the broken water. Later some sarnais, or skin rafts, were got from the Rávi, and then the real nature of these appearances was ascertained. The appearance of the holes in the weir surface when the weir got dry was very remarkable. They were found all to have begun at about 40 feet from the actual crest of weir, or second wall, which was just where the water passing over the weir met the backwater and made a curl in the water surface. The action of this appears to have been to pick out the stone, and of course when once a hole was made the stones above followed, and the hole soon extended until it was stopped by the masonry wall, which was left bare in some places as much as six feet from the crest. This shows very forcibly the necessity for a masonry wall in a weir of loose stone destined to withstand high velocities.

When these places were surveyed and laid down on the plan, a line could be drawn parallel to the weir crest very nearly through the lower

edge of each. The Inspector General of Irrigation thereupon ordered a wall three feet thick to be built on that line, the effect of which will no doubt be to put a stop to the action. None occurred in 1873, but then the floods of this season were not heavy. There was very little damage done at the toe of the weir talus in 1872, which no doubt was due to the stone put in to fill the holes formed in 1871; the greatest width cut away did not exceed 10 feet as compared with 40 in the previous year.

The embankments were completed before the floods, and stood well; only some trifling leakage under them was seen, which was due to the nature of the soil. A great deal of silting up took place in the old eastern channel.

During the working season of 1872-73, the front wall of the weir was raised to the full height, except the coping which it is of course not advisable to put on until the full height of weir is required for the canal supply. The additional wall ordered by the Inspector General was also put in, and in fact the weir and subsidiary works were practically finished. The total quantity of stone in the weir is 4,660,000 cubic feet.

The floods of 1873 were very low, and did little damage to the weir. Some transference of action may be looked for when conditions are altered by raising the front wall to its full height, thus shifting the actual crest of the weir 30 feet up-stream.

It remains now to give a short notice of some of the works on the canal line to complete the proposed plan of the present article.

The bridges are not heavy works. The width of the canal being 70 feet at bottom as far as the 32nd mile, the first class bridges were amply provided for by giving 84 feet of waterway. This was done in three spans of twenty-eight feet. The navigation requirements\* prescribed a height of 18½ feet to springing. The bridges are most of them built of stone, a few only being of brickwork where there happened to be a long lead from the stone quarries, which are in offshoots of the ridge running from Alwar to Delhi. The arches are segmental. The towing-paths are carried round the abutments on stone corbels, upon which a pathway of red Agra slabs 4 feet wide is laid.

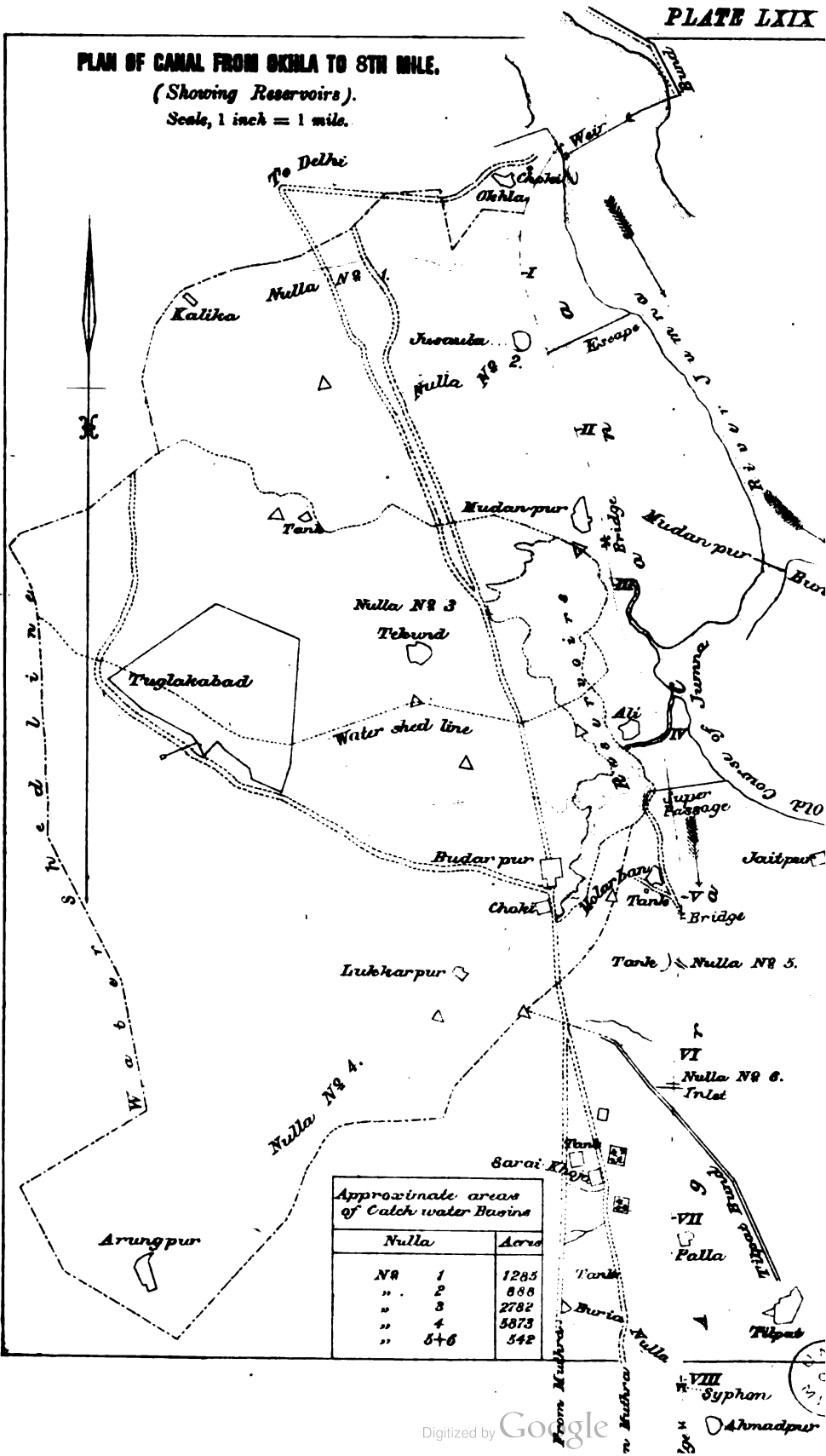
The depth of foundations in the upper part of the canal is 8 and 10 feet below canal bed. The foundation of the bridges down to mile fourteen had to be put in below water level. Those below were built in dry pits. The land wings of the earlier bridges are too short, and their

\* A clear rectangle 20' x 10' to be left above Kharif high-water line.

PLAN OF CANAL FROM OKHLA TO 8TH MILE.

(Showing Reservoirs).

Scale, 1 inch = 1 mile.



Approximate areas of Catch water Basins

Nulla	Acres
No 1	1285
" 2	888
" 3	2782
" 4	5873
" 5+6	542





section too light. The second class bridges are of two spans of 30 feet, and the bridges of course become smaller and smaller, further and further down the canal. All the arches are turned in rings of brick-on-edge, bonded where the radiations permit through two courses by bricks-on-end. No cutting of bricks whatever was allowed except in keying up. The arches were turned on wooden centres, and the sinking in no case amounted to half an inch on the 28 feet spans, and in most cases was much less.

In the second mile is placed a scouring escape, with a waterway somewhat exceeding that of the canal head, *i. e.*, there are fourteen openings of 6 feet instead of twelve as in the head. The outlet is by a channel about 1,500 feet long back to the Jumna, and the object is to generate velocity enough to stir up and carry away the silt, which will be deposited between it and the canal head. This work is built on well foundations.

At mile eight a large nulla, called the Buriyá, is crossed. It is capable of discharging 2,000 cubic feet a second, having a steep and rocky, though short course. It is provided for by a partial syphon having seven culverts, 6 feet wide and 4 deep, the velocity through which in high floods will be 12 feet per second. Bolts are built into the piers of these culverts, and the culverts are covered by large stones 9 inches thick bolted down. A massive breast wall on either side supports the canal bank, and the ordinary earthen section is carried over the syphon culverts so that the canal flows over the work without any change of current whatever. This work is provided with a floor of massive rough ashlar, the entrance and egress for the nulla being also built with large stone.

Near the canal head the drainage from the rocky hills, which abutting on the river form the point d'appui of the weir on the right bank, has to be crossed. The ancient city Tuglakábád stands on this ridge (the remains of its magnificent walls being clearly visible from Okhla) and a good deal of drainage which collects near it develops itself during the rains in two somewhat formidable torrents, one of which crosses the canal at the third mile at Madanpur, and the other at the fourth at Ali. The latter is the larger and its discharge in very heavy rains, reckoned on its catchment area, is 6,495 cubic feet per second. In addition to these, one smaller water-course crosses the canal close to Okhla, and another at Jasaula. These two are provided for by inlets, but those at Madanpur and Ali are too considerable to be treated so lightly. The mode of dealing with them has been to form embankments across their beds

continued on either side until they meet the contours of the ground at a level high enough to contain the water likely to be required to be stored at one time on the occurrence of an extraordinary flood. A fall of  $7\frac{1}{2}$  inches of rain in  $4\frac{1}{2}$  hours, which was observed not many years ago at Seharunpore, is the basis of calculation; with the assumption that two-thirds of the amount of water so calculated may present itself for disposal at a given moment. This is probably an ample allowance, but the conditions are quite different from those usual in this part of India. The beds of the torrents and the whole gathering ground are hard, rocky, and steeply inclined, and contain but little cultivated land. Consequently the rainfall is discharged with great promptitude, and the nullas are quickly in flood and quickly dwindle down again.

The embankments across the beds of the two torrents have a core of rubble masonry, and each is provided with a culvert passing through it, and discharging into an open channel which leads to an inlet into the canal. On the head of each culvert, above the embankment, and in the reservoir formed by it, stands a tower somewhat similar to those in the Bombay and other water-works reservoirs. Each tower is provided with three large iron sluices at different levels, which discharge into the hollow interior of the tower and thence into the culvert. This plan admits of water being drawn off always at, or near, the surface where it is comparatively pure, and passed into the canal without injurious effect. The silt settles to the bottom of the reservoir. It is obvious that the result will be the gradual silting up of the lower levels of the reservoir.

The storage of these reservoirs is 160,000,000 cubic feet, and their area when full would be 474 acres.

The canal does not however depend for its safety on the towers being enough to carry off the waters of the torrents; on the contrary, it is not expected that they will suffice, and a superpassage (or aqueduct over the canal) is provided near Ali capable of carrying 2,000 cubic feet per second. This is placed close to the Badarpur or Ali nulla, which is the larger of the two, at a point where a bend brings it close to the canal.\* The superpassage consists of a double open tube or trough, giving a total waterway 80 feet wide and 10 deep, supported by three girders which form the sides and the partition. The ironwork is in the form of a

*See Plate No. LXIX.*

continuous girder over three spans of 28 feet (the same as the bridges) with piers 5 feet thick, making a total length of 99 feet. Such a depth of water as 10 feet produces a very heavy load which, though evenly distributed and gradually applied, produces very great shearing strains. Accordingly while the flanges are quite below the usual proportion there is a great deal of stiffening on the web. The total load on the central girder is 4.55 tons per foot run, that on each of the outer girders of course just half this amount. The shearing strain over the piers for the central girder is 90 tons, or 9 tons per foot of vertical section. The webs have been carefully stiffened by angle and T-irons to support the strains. To provide further against extraordinary floods, the top level of the trough on each side is one foot below the masonry walls of the approach. The superpassage therefore if brim full will act as a weir, and spill over on each side, forming a double weir in addition to the discharge through the sections. The masonry walls limit this possible action and prevent its being dangerous. This work is somewhat interesting as being the first application of iron to the construction of a superpassage in this part of India. After passing through this aqueduct the water will descend by a vertical fall of 12 feet, built in masonry, into an earthen channel 1,000 feet long, at the end of which it reaches an old channel of the Jumna by a further descent of 15 feet arranged in two connected falls.

The Chajúnagar weir (at  $32\frac{1}{2}$  miles) is an interesting work. It is designed on the "expansion" principle—that is, the crest is elongated by placing it at an angle of only  $15^\circ$  with the axis of the canal and the bed is slightly widened out for the purpose. The length of the crest is 193 feet, the cross width of the canal at surface being 84 feet only. The lock is on the direct line of the canal, and parallel to it. A direct scour through the lock is thus secured, and the necessity for a lock channel avoided. The filling and emptying of the lock is provided for by a culvert in the right wall of the lock, entering above and issuing below the fall, on the same principle as in the Okhla lock.

This work was built with material from Pahera, where a first rate stone with natural bed and in large pieces is found. It is trimmed and coped with red Agra stone.

At mile thirty-eight, the first ordinary escape is thrown out just below the village and choki of Báta. It is about three miles in length, and reaches the Jumna at the village of Kúshak. The escape head consists of

ten openings of 6 feet each, which are placed in the line of the left bank, and the channel is at right angles to the canal. There is a fall of 2 feet into the channel, which is 53 feet wide, with a gradient of 1 foot per mile. It gains the Jumna by a flight of three falls at Kúshak of 10, 13 and 7 feet, respectively. No regulator has yet been built across the canal, but one will probably be required.

The next work of special interest is the Mathra navigation. It leaves the canal at Aríng at the seventy-seventh mile, and is nine miles in length. It was first contemplated to combine an escape and navigation line in one channel, but this project has been abandoned, and as the work now stands it consists of a still-water channel ending in a dock, 400 feet long by 100 feet wide, close to the town. There is a lock at the head with level floor, and two others to overcome the natural fall, each with a drop of  $8\frac{1}{2}$  feet, are provided at convenient points on the channel. The next special work is the Chota Kosi fall and lock, at mile  $85\frac{1}{4}$ , somewhat resembling those of Chajúnagar, but the crest of the fall is here at right angles to the canal; the volume of water being much less admits of this, and a length of only 60 feet of weir crest is given. Down to this point the fall of the canal per mile is 12 inches, which it takes at Chajúnagar, but from hence it has been necessary, in order to meet the demands of navigation (ever at variance with those of irrigation) to reduce the fall suddenly to 4 inches per mile only, with which gentle gradient it proceeds to the Malikpúr weir and lock at mile 96. It then resumes its former gradient of 12 inches per mile.

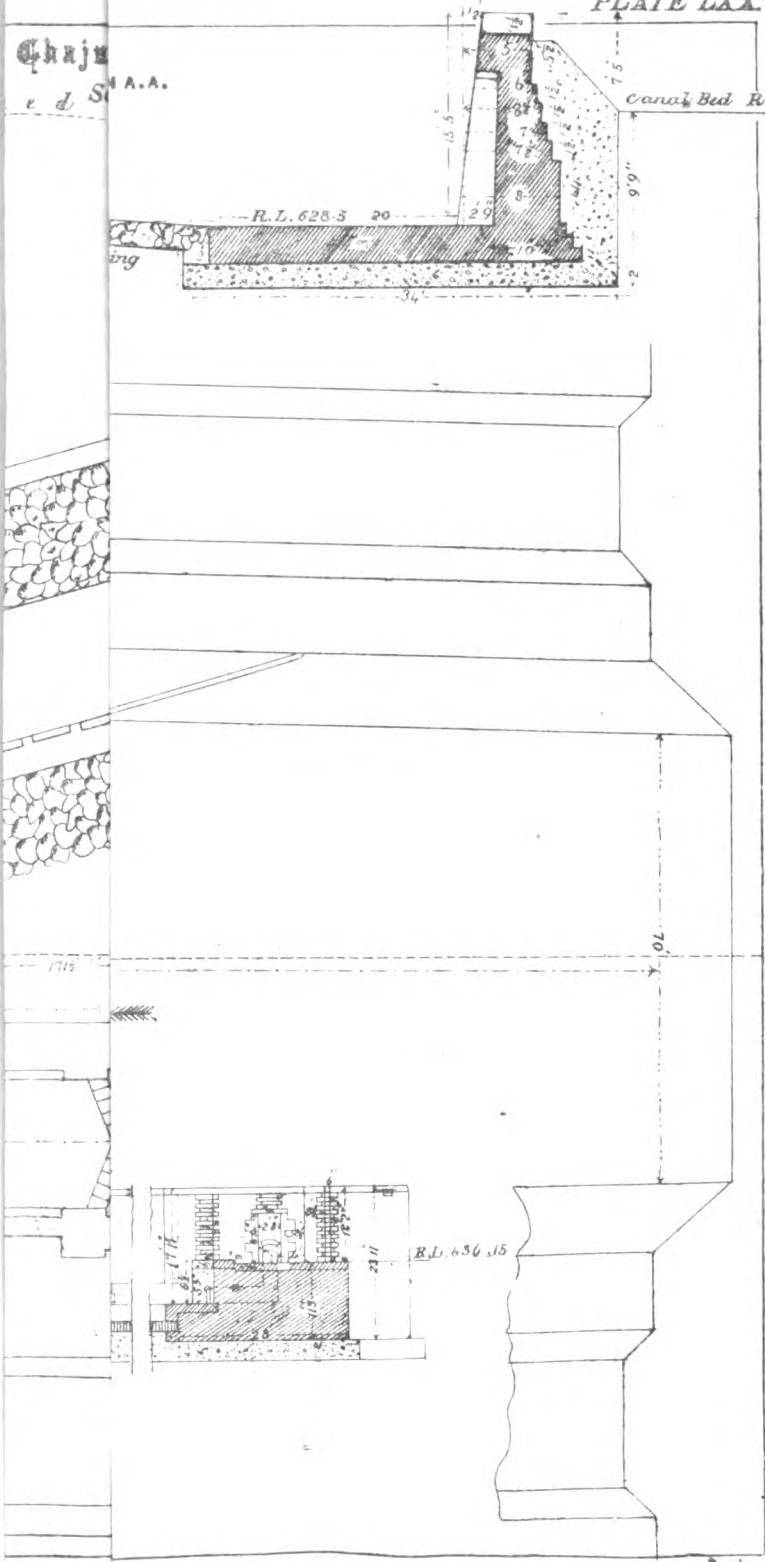
The Malikpúr weir and lock resemble those at Chota Kosi, but here the weir has a crest of only 40 feet in length.

The Agra navigation takes off just above the 100th mile at Jodhpore, and has a still water channel 16 miles long. It leaves the canal at an angle of  $30^\circ$  with its axis, and runs parallel to the Mathra and Agra road till it crosses it four miles from Agra. One furlong from the head of the navigation line, but above the head lock, an escape called the Kítam escape is thrown out to the Jumna at right angles to the left bank. This escape is  $6\frac{1}{2}$  miles in length and has five falls, viz., one of 4 feet at its head and four others of ten feet each. A regulator is provided to close the main canal when the escape is working. There are in the navigation channel eight locks. One of these is at the head, and has a descent of  $5\frac{1}{2}$  feet. The others have each a descent of 11 feet. On reaching the Civil

Chajm

e d St A.A.

Canal Bed R.L. 636.15





Station, which it passes on the north side, it descends a natural ravine and joins the Jumna about one mile above the new railway bridge. It will undoubtedly form an important line of communication.

To meet cantonment rules, a curve had to be put in round the station of Agra, as the general alignment of the canal would have brought it much within the sacred zone of five miles, considered necessary as a protection against the evil effects of irrigation. By this time the canal has dwindled to the dimensions and performs the duties of an ordinary distributary, and it ends at mile 140 from its head by discharging any superfluous water into the Utangan, a tributary of the Jumna, near the town of Fatihabad. The tail falls are situate 27 miles from Agra, as the crow flies, and nine miles from the confluence of the Utangan with the Jumna. The descent is upwards of 50 feet, and is arranged in four falls. It may be presumed that the volume of water sent down them will never be great, as there so many demands on it on its way from Okhla.

Of the distributaries or rajbhas there is no need to say much. They are fourteen in number, as will be seen by an inspection of Table B, and their discharges vary from 140 cubic feet a second down to 25 cubic feet only.

They are all carefully aligned on the watershed line of the district they are intended to water, as ascertained by careful levelling, for the country does not contain any very marked features. The general fall of the country is towards the west, where there is a marked depression, running generally parallel to the canal, from about the sixtieth mile. This will facilitate the drainage, which will doubtless be required eventually if the evils now felt in the older canals are to be avoided here.

Reference was made at the beginning of the Paper to the Supplementary Canal from the Hindan. The works consist of a dam across the river immediately below the East Indian Railway bridge and attached to it. It is being built on wells carried down 20 feet below the low water level. The superstructure is like that of the escape dam at Dhanauri, on the Ganges Canal, and is 540 feet in length.

The Head is designed on the skew, its centre line forming an angle of  $30^{\circ}$  with a normal to the dam; an ugly and objectionable curve is thus avoided. There is a lock between the head and the railway bridge.

The channel (crossed by three bridges) runs in a nearly straight line to the Jumna, which it reaches after a course of nine miles at a point one mile



above the Okhla weir. The bottom width of the channel is 24 feet, side slopes  $\frac{1}{2}$ , and it is to discharge 291 cubic feet a second with a depth of 5.6 feet.

The channel is closed by a lock at the tail to exclude the flood waters of the Jumna, which would otherwise reverse the ordinary flow of the channel and run into the Hindan.

The total estimated cost of the Agra Canal is Rs. 5,014,000. That of the Okhla weir and works is Rs. 832,000, and of the Hindun cut Rs. 410,000. The total area of irrigation is calculated at 300,000 acres, and the probable income when the irrigation is fully developed is expected to be Rs. 576,000, besides about 40,000 from navigation and mill-rent.

*June 1874.*

H. H. J.

## No. CXXVII.

## THE RIGI RAILWAY ON THE LADDER SYSTEM.

[*Vide* Plates LXXI. to LXXIV.]

BY MAJOR T. F. DOWDEN, R.E.

*Translation of description by* PROFESSOR J. H. KRONAUER.

THE Rigi mountain, whose elevation of 1,800 metres, offers one of the most imposing views, and whose elegant hotels give at the same time hospitality to many hundreds of visitors, is visited yearly by about 40,000 persons on an average. Most of them undertake the rather fatiguing ascent on foot, a great number take advantage of somewhat expensive horses, or are carried up. Long ago the desire was expressed for some easier routes, but the accomplishment was always delayed, until at last, to the terror of the guides, carriers, and horsekeepers, the project of a railway was started, and in a short time assumed a definite shape.

As the originator of this bold undertaking, we have to name the engineer, Mr. N. Riggenbach, Director of the Central Railway in Olten, who had already obtained a patent in 1863 in France for a system of Mountain Railways on the principle of the Ladder Rail; but though the model made for the exposition of this working principle served to procure for it many well-wishers, it did not succeed in bringing together the requisite capital to make a trial on a large scale. Only when, in the year 1868, the news came from America that, upon Mount Washington, in the vicinity of Boston, a similar railway, with an ascent of 33 per cent., was in the course of execution, and after this railway had been carefully examined by a skilful engineer, then only the three engineers—Riggenbach,

Näeff, and Zschokke—associated together to establish such a railroad on the Rigi. They obtained, in the beginning of 1869, from the Luzerne Government, a concession for the laying down and working of a railway on the South declivity of the Rigi Mountain, viz., from Vitznau on the Vierwaldstatter Lake to the Luzerne-Schwyz canton boundary, above the Kaltbad, with a prospect of a continuation (upon Schwyz territory) to Rigi Kulm. The formation of a company in shares encountered no difficulties, the requisite capital of francs 1,250,000 (£50,000) was subscribed for at once.

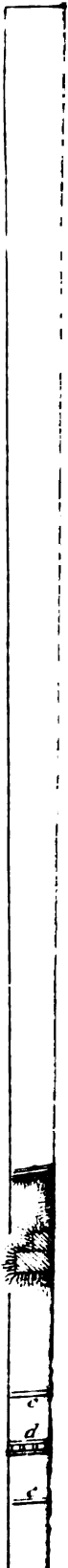
In November of the same year the works began, and the road would, without doubt, have been completed by the autumn of 1870, if, in consequence of the Franco-German war, the delivery, from France, of the rails had not come to a stop.

The length of the railroad is 5,340 metres (3·26 miles) and the difference in level of the termini is 1,200 metres (3,900 feet). The railroad begins in Vitznau, near the Seegestade, winds through the village with an elevation of 0·067, and passes thence against the precipice of the Rothfluh into the considerable ascent of 0·25 (1 in 4). This ascent varies, however, on the remaining distance between 0·18 (1 in 6) and 0·25 (1 in 4); the maximum of ascent exists for about one-third of the entire railroad. The rest has an incline of 0·21 (1 in 5) on an average. All the curves which occur in the road have a radius of 180 metres (585 feet).

Above the Rothfluh the railroad goes through a tunnel cut through the Nagelflüh, of 75 metres in length, and immediately after goes over a bridge of 76·5 metres (247 feet) in length, crossing the Schnurtobel, which is 23 metres in depth. A little higher up, the road cuts rather deep into a projection of rock, and this place, upon the nature of which there had been some misapprehension, occasioned a considerable delay in the progress of the works. After this, however, the emplacement showed itself exceedingly favorable for the laying down of the railroad.

*Superstructure, Plate LXXI.*—The superstructure consists of cross sleepers *a* (Figs. 1—3) 2·40 metres (7·8 feet) in length, which are totally imbedded in the ballast at a distance of 0·75 metres (2·454 feet) apart and forming a ladder, with two longitudinal sleepers *b* bolted thereon; this ladder being intended to take the rails *c* and the iron-toothed cogways *d e* lying between these rails.

For the further strengthening of that ladder, masonry foundations are





let in at distances of 0.75 metres (2.45 feet) in the embankment to a depth of 1.50 metres (5 feet) (upper side). Each of these foundations contains two strong freestones (square stones) which protrude over the masonry at sleeper's height and place themselves against two consecutive sleepers. In this manner it is expected that the foundations are secured against any possible slip.

The above-mentioned rails have the universally adopted gauge of 1.435 metres (4 feet 8½ inches), and are lighter than ordinary railway rails; they weigh, per running metre, only 16½ kilogrammes (33 lbs. to the yard). The cog-rod *d e* inserted in the middle serves to catch the cogs of strong cog-wheels of cast steel, which are attached to each axle of the locomotive, as well as on those of the passenger-wagons. It consists of two [shaped rolled rails *d*, through which the wrought-iron teeth *e* are passed. The latter are 26 millimeters in height, below 55 millimeters and above 86 millimeters in width (*vide Fig. 17, Plate LXXIII.*); they are pinned together with keys somewhat flattened above and below (*Fig. 12*) in the walls *d*, and are rivetted on the outside. This cog or grip-rod is put together from pieces of 3 metres each in length, and the ends of two such pieces are fastened by fish-plates inserted below, and well screwed together. As the lowest tooth of each grip-rod piece is the most exposed to a break from the rail in consequence of a break in the latter, trials have been made, what force would be required for the break of such a tooth from the side walls. At the first trial the distances from the plug hole up to the flat ends of the walls was 28 millimetres, equal to the half of the interstice between two teeth. With a pressure of 26 tons, the wall was torn out from the middle of the rivet hole. Thereupon another grip-rod piece was taken, by which the distance from the plug-hole up to the ends was 50 millimetres. The breaking weight here increased to 48 tons. In the first case the so-called *shearing* resisting power was 3.95 tons; in the second case, 3.83 tons per square centimetre. In consequence of this having been established, the joint of two grip-rod pieces was placed, not in the middle of two teeth, but 35 millimetres from the uppermost and 22 millimetres from the lower tooth, as shown in *Fig. 12, Plate LXXIII.*

Particular difficulties were encountered in making the segments of this grip-rod falling in the curves of 180 metres radius, through which the teeth had to be arranged to go converging.

At the two ends of the railroad are stations. and in the middle of its

length there is a place for crossing trains. As the grip-rod makes the applying of usual crossings impossible, the transfer of the train upon the side-track  $c' c'$  (*Figs. 4 and 5, Plate LXXI.*) is arranged by means of a turn-table revolving upon the pivot  $f$ . This apparatus consists of two walls  $g$ , of double T-iron, which bear the rails  $c^2$  and are joined below by the ties  $h$  as a solid frame. The rollers  $i$  repose upon rail pieces  $k$ . The turning of this bridge is done through the windlass  $l$ , which sets in motion the grip-rod  $m$  which is joined with it in one link. The length of the bridge is 15 millimetres (50 feet), and is sufficient to take the locomotive and the only passenger-carriage usually attached.

*Bridge over the Schnurtobel, Plate LXXII.*—This already previously mentioned bridge stretches in one curve of 180 metres radius, and with an ascent of 25 per cent. (1 in 4) over the Schnurtobel, the profile of which is shown in *Fig. 6*. It consists of two plate girders  $n n$  (*Fig. 8*) which are braced below by horizontal T-irons  $o$  and flat bar-irons  $p$ . The compression beams  $q$  are 30 c. metres in breadth. Upon these girders, the cross beams  $r$  of double T-iron are placed, and upon these again the longitudinal sleepers  $t t$  for the grip-rail  $d e$ , and the rails  $c c$ ; two boards  $u$  forming side walks are also placed thereon. The two edges of the bridge are provided with light iron railings  $v$  (*Figs. 8 and 9*).

The lower end of the bridge is supported at  $w$  in a cut in the solid rock; the other end rests at  $z$  upon masonry, and finds here the required play-room for the expansion occasioned by the changes in the temperature. The bridge is further supported by the very light looking piers  $a' a'$  which are put together out of double T and angle-iron (*Figs. 10 and 11*), reposing upon stone sockets.

*The Locomotive (Plate LXXIII., Fig. 13)* was constructed by the Engineer Riggerbach in Olten, and built in the workshops of the Central Railway there. The peculiar construction of the same is adapted to the circumstances under which it is called upon to act. The iron framework  $b'$  reposes upon two axles  $d'$  and  $e'$ , and supports in the middle an upright tubular boiler  $f'$ , which is so placed that it only comes in a vertical position when the railroad upon which the locomotive travels has attained an ascent of about 19 per cent. The upright position of the boiler had to be selected, because in a horizontal one the difference of the height of water on the fore and hind ends with respect to the tubes, on a considerable ascent, would have been too great; the inclined position of the boiler

OVER THE SCHNURT

Fig. 6.  
Side Elevation of the Bridge

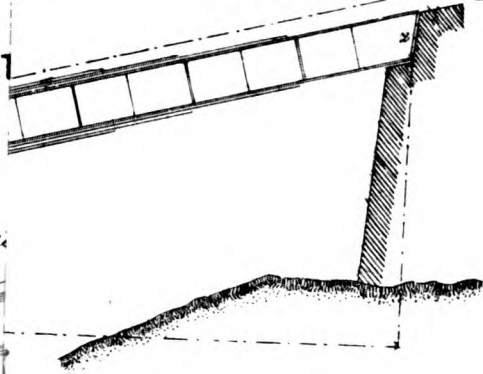


Fig. 10.

Grider Pier  $\frac{1}{100}$

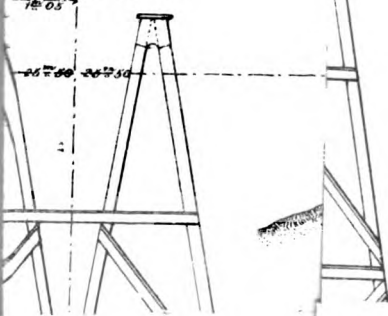






Fig. 12.  
Longitudinal Section of Ladder Rail

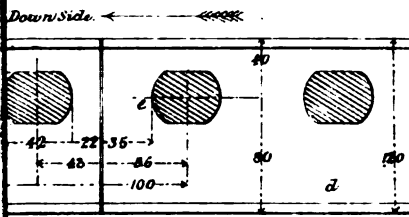


Fig. 15.  
Driving Axle

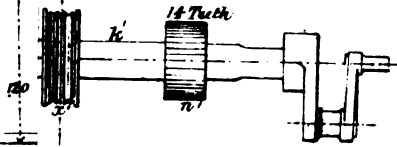


Fig. 14.  
Transverse Section of Ladder Rail

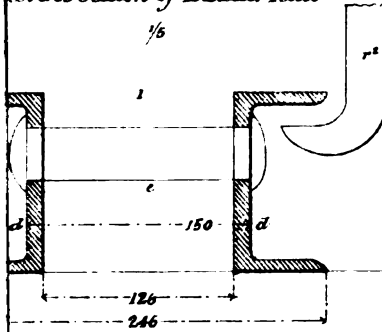


Fig. 16.  
Wheel Axle

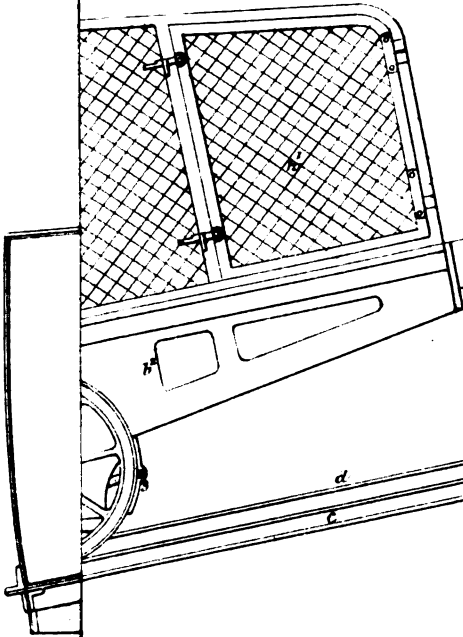
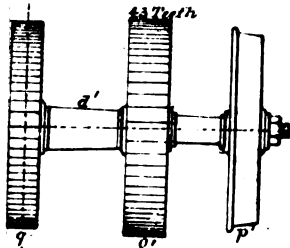
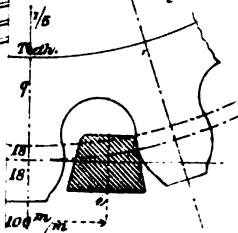


Fig. 17.  
Ladder Cog and Ladder Cog





to the frame makes the differences, which arise with an upright boiler, less sensible. In consequence of this, the locomotive assumes always a similar position to the direction of the railroad, that is, both on ascending as on descending the same side of the locomotive is directed upwards. Upon the descending side the tender  $g'$  is placed, consisting of a water and coal-box fastened upon the carriage frame; on the other end there is a compartment  $h$  made of trellis work for the reception of luggage.

On each side of the locomotive there is a steam-cylinder  $i'$ , the piston rod of which is joined in the usual manner to the crank  $k'$  (*Figs.* 13 and 15). This contains also the eccentrics  $l'$  and  $m'$  for the link motion, but is not, as in other locomotives, also at the same time a wheel axle, but is connected with the actual locomotive axle  $d'$  (*Fig.* 16) through the cog-wheels  $n' n'$  and  $o' o'$ . The machinery pieces  $n'$  are 0.2227 metres (8.58 inches) in diameter, and have 14 teeth, whilst the axle wheels are 0.6842 metres (2.223 feet) in diameter and have 43 teeth. As the axle  $d'$  does not follow the movements of the running wheels, but those of the driving-axle  $k'$ , the wheels  $p'$  are placed loosely upon the journals of the same, and merely kept from gliding off by nuts. Upon the middle of the axle  $d'$  lies the grip-wheels  $q'$ , which catches in the grip-rail  $d' e'$  in the middle of the railroad. Its diameter is 0.6366 metres and it has 20 teeth. The teeth are rounded off and work with the least possible sliding upon the teeth  $e'$  of the grip-rail, the transverse section of which is seen in *Fig.* 17. It is through the action of this cog-wheel that the entire load of the steep railroad must be borne; it is therefore manufactured out of first-rate cast-steel. The teeth of it are punched out of the entire piece, and formed with great precision to the required shape.

The other locomotive axle  $e'$  carries also two loose running wheels  $r'$ , and in the middle a tightly wedged cog-wheel, similar to the one  $q'$  upon the other axle. This has however no independent turning motion, but serves exclusively as a brake wheel, when the machine has to be stopped. For this purpose its axle is provided with two brake rods near it upon which the two brake blocks  $s'$  can be pressed, through the handle  $t'$ , which is attached to the tender, and the various connecting pieces  $u'$ ,  $v'$ ,  $w'$ , &c. A smaller brake  $x'$  is fastened to the driving axle  $k'$  (*Fig.* 15), which can be worked from the crank  $y'$ . None of the brake-blocks are smooth upon their broad sides, but indented wedgeshape (this refers also

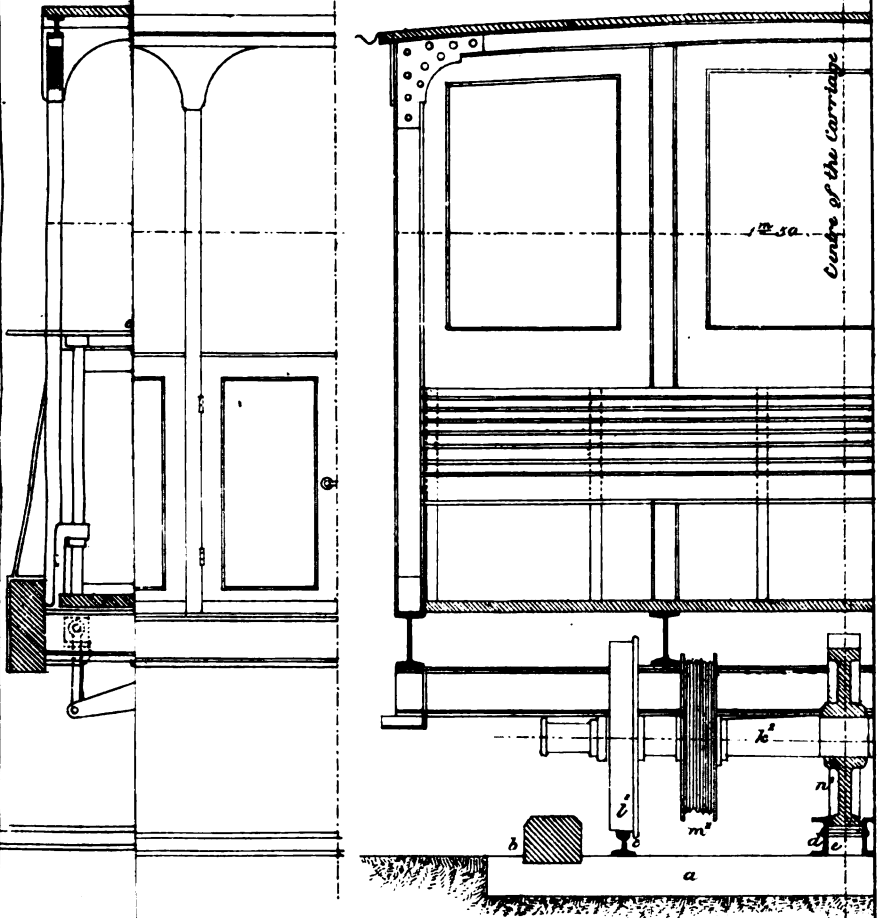
to the brake-blocks mentioned hereafter, attached to the axles of the passenger carriage), and this can be seen in *Fig. 15*, and conforming to this shape the wooden brake-blocks annex themselves. It is quite apparent that the action of the brakes is considerably enhanced thereby, and in case of need, all possible slipping can be avoided.

The steam issuing from the boiler, by opening of the throttle valves  $a^1$ , enters at  $b^1$  through the fork-shaped tube  $c^1$  branching off towards the two cylinders; the steam going off is carried through the tube  $d^1$  to the blast pipe. This is the usual course in locomotives, and takes place here in the ascent. It is entirely different in descending; and here the question of the security of the train against an acceleration surpassing the normal velocity arises. It must be added that the travelling speed at the ascent as well as at the descent is the same, in fact a comparatively small one, 4,800 metres (3 miles in an hour). During the descent the admission of the steam into the cylinder is completely shut off by means of the valves  $a^2$ . The pistons work backwards and forwards with the motion of the engines, and the main object is only to retard them in such a manner that their re-action upon the cog-wheel  $q'$  should regulate the motion of the latter to the required speed. This is done through atmospheric air, which is sucked up by the piston through the lower part of the tube  $d^2$  and again expelled through the tube  $c^2$ . For this purpose there is attached to the latter at  $e^2$  an outlet cock, the opening of which is regulated in such a manner that the air filling the cylinder can only be discharged with considerable resistance (*i. e.*, through a small opening.) The space included in the two slide valves and the tube  $c^2$  thus assumes the functions of a wind-boiler, the pressure of the air in them taking the place of the steam pressure in ordinary boilers owing to the resistance to the escape of the air through the small opening. The pressure in these parts must be equal to that in the boiler required for the ascent. A very great increase of pressure takes place in the cylinders from the beginning towards the end of the stroke. The entrance of the air takes place at the box  $f^2$ , in which two valves  $g^2$  and  $h^2$  of 0.12 metres diameter are placed. One of the valves,  $g^2$ , opens in the upper part of the tube  $d^2$  and allows the passage of escaping steam towards the blow-pipe; the other valve  $h^2$  is placed upon the bottom of the box, opens inwards in the interior of it, and allows atmospheric air to flow in. Both valves are in such a manner connected together through the lever  $i^2$ , that alternately one closes

ILWAY.

Long

Fig. 19.  
Transverse Section





through the opening of the other. At the escaping of the stream,  $g^2$  opens and  $h^2$  will be closed; on the exhausting of the cylinder, that is, on the descent, the contrary action takes place. The air-brake acting through these natural means works as strongly as securely, which has been proved by many trips. It remains to be remarked that a small pipe takes water from the tender to the cylinders under the slide-valves on the descent. Therewith is obtained first a cooling on the one hand, and, on the other hand, the drying up of the piston packing, &c., is prevented.

Finally, a farther very important contrivance has to be mentioned, which prevents the locomotive from running off the rails in case a foreign substance were to come between the teeth. This is shown in *Fig. 14*, and consists of strong angle irons  $r^2$ , of 18 centimetres in width, which are fastened in front and behind to the locomotive, and catch under the upper flanges of the ladder rail sides  $d$  with horizontal and vertical play-room of 15 millimetres each. The weight of the machine with loaded tender is 12,500 kilogrammes (12·5 tons).

*Passenger Carriage (Plate LXXIV., Figs. 18 and 19).*—The construction of these carriages is clearly shown in the drawings. Low entrance doors afford the passengers an unobstructed view of the lovely scenery. Nine benches, affording six places each, are placed in the interior of the carriage. The peculiar shape of the same (*Fig. 18*) allows a comfortable seat in all positions that the carriage may have to assume upon the inclines. The benches consists of five light wrought-iron frames each, upon which wooden ribbands are screwed for the seat and the back to be fixed to.

Each of the two carriage axles  $k^2$  (*Fig. 19*) are provided with two tightly wedged running wheels  $l^2$ , with two indented brake-blocks  $m^2$ , with a cog rod wheel  $n^2$ , and with two brake contrivances  $o^2$ ,  $p^2$ ,  $q^2$ . With the help of these latter the conductor is able to stop the carriage suddenly at any place he likes, as by the drawing on of the brakes, the axles, and with them the wheels  $n^2$ , are brought to a stand, and then held fast in the ladder rail  $d e$ .

Finally, it must be remarked that there is no coupling between the locomotive and the passenger carriage; the latter simply leans against the former, and when travelling in either direction, is naturally on the upward or ascent side of the locomotive.

By careful examination of all the arrangements one must confess that not only is the class of design particularly well adapted for mountain rail-



ways, but also that all the arrangements are so carefully contrived that the working is perfectly safe and free from all danger. The future will teach us how the railroad, for the laying down of which the utmost endurance and solidity have been sought, will resist the action of changes in the temperature, displacements of the ground, &c. As, however, the line will only be worked during the dry season—at the utmost six months of the year—there will be ample time to repair all possible damage which may occur. The greatest security to the working can however be found in the fact of the very small travelling speed, and that the train and also the passenger carriage *alone* can be stopped immediately, when necessary.

---

*Letter from the Committee, dated Aarau, October 16th, 1873.*

DEAR SIR,—In reply to your favor of 2nd instant, wishing for details concerning the Rigi Railroad Company, we beg to state the following:—

The Rigi Railroad was constructed in the years 1869 and 1870 by Messrs. Näeff, Riggenbach and Zschokke; M. Riggenbach, the inventor of the system, being the mechanical engineer, while Messrs. Näeff and Zschokke constructed the road bed.

Since then the road has been run constantly during summer seasons, the number of passengers amounting, for this year (1873) to about 100,000, the net profits of the stockholders, to about 20 per cent. on the outlay.

The enterprise having met with great approval, a Company was started to work the system on other mountains and in other countries, and patents were accordingly taken out where they could be obtained. The company is organized on a capital of 12,500,000f. (£500,000) with Messrs. Riggenbach and Zschokke as its leading engineers, and a large establishment has been constructed under their direction in Aarau for producing all materials, rails, locomotives, &c., necessary for mountain railroads.

Prominent bankers have charge of the financial part.

Six roads in this and other countries are under contract and will be finished in 1874 and 1875; ten others are being surveyed.

The system (ladder-rail) can be applied on inclines of from 5 to 25 per cent. (1 in 20 to 1 in 4).

Replying to your special questions, we may remark:—

1. The locomotive ready for use weighs about 15,000 kilogrammes (15 tons), and costs about 45,000f. (£1,800).
2. A passenger wagon weighs about 4,000 kilogrammes (4 tons), and costs about 8,000f. (£320).
3. Rails weigh 10 kilogrammes (22 lbs.) per yard.
4. Ladder rail weighs 55 kilogrammes (121 lbs.) per yard.
5. Superstructure costs about 110,000f. (£4,400) per mile.
6. Rigi railroad costs 650,000f. (£26,000) per mile.
7. The descent is made simply by compressed air. The brakes are only applied to stop in extraordinary cases, &c.; to stop the trains at once, a train (one wagon and locomotive) can be stopped at one yard's length.
8. The locomotive works with a pressure of ten atmospheres.
9. Only best coals are used.
10. With 25 per cent. incline (1 in 4) the locomotive can only push one wagon with 54 persons and luggage; with only 10 per cent. (1 in 10) the locomotive could push or pull 180 persons with luggage.
11. The rails can be laid on ordinary gauge or narrow gauge. Rigi railroad has the normal gauge of European railroads.
12. The Rigi Railroad was finished last year for three miles with an elevation of 4,500 feet above the level of the sea.
13. On inclines of 5 to 15 per cent. (1 in 20 to 1 in 7) the locomotive can run six miles an hour, at 15 to 25 per cent. (1 in 7 to 1 in 4) four miles an hour.

To acquaint you as much as possible with the whole system, we enclose here drawings of locomotives, wagons, ladder-rail, &c., &c., for your inspection.

Should you think it probable that such roads would be useful in your country and could be run profitably, we would put our engineers at your service for the location of lines, the construction of which you could then easily execute by your own engineers according to plans we would hand you.

Our Company would furnish you with locomotives, wagons, rails, ladder-rail, in fact the whole necessary permanent and rolling stock, and

we even could send you some experienced engine drivers for working on roads at the beginning and instructing your workmen.

H. RIGGENBACH.

---

*Remarks by Major T. F. Dowden, R.E.*

The advance of science which every day tends to bring the advantages of refined civilization more and more within the reach of the million, was certainly never more evident than when steam was first applied to locomotion. The journeys which the traveller made with much toil in a day, are now performed with ease and comfort in an hour: the friends we were able to meet once or twice in our lives can dine with us any day they like: countries lying barren and waste have sprung into cultivation, affording support to happy families; and in fact there is hardly a position in modern economies, domestic or political, which does not hinge, directly or indirectly, on locomotion by steam.

Whether these advantages are necessary or not to the ultimate destiny of man is a question which need not be discussed here; but it seems very evident that communities have it in their power, by good government, attention to moral teaching, by industry and energy, to increase their population, and that civilization, which supplies the comforts and blessings which almost inevitably accompany, will, if these attributes be steadily kept in view, not lead, as far as we can see, to anything to prejudice the cause of humanity in the distant future.

Taking things as we find them on this earth, it certainly appears as if the prosperity of countries and the position of the people in the scale of nations was intimately associated with the amount of facilities they have for locomotion. England, covered with a network of railways, is an example of the constant moving of the produce of one district to supply the wants of another, and hurrying of the people to and fro in search of health or wealth. How very different is a neighbouring state, poor Spain, torn by internal dissensions, with no commerce, and, comparatively speaking, no railways. She has a geographical position in Europe second to none, with mineral wealth untold, to occupy her people, if the country could only be opened up. Turn to France, Belgium, Germany,

and the new world of America. The latter, more than any country, exemplifies the progress of a nation pioneered by railway enterprise. Vast deserts, mountains, valleys, and rivers are unable to oppose barriers to the persevering energy and skill with which man has been gifted, apparently to enable him to utilise, to the utmost, the resources of the earth.

The only limit to his progress, humanly speaking, appears to be the one essential, viz., that the undertakings, to use a homely term, should pay.

In order that railways may pay, it appears that two things are requisite: the first is, that economy in construction and working should be exercised; and the second, that the public should desire and be able to avail themselves of the advantages offered to the extent proposed.

The former will be ensured by the careful exclusion of all unremunerative expenditure in construction processes, or such as does not contribute to minimise the power required for working; the latter will be influenced in a large degree by the comfort, safety, and celerity, which may be available at all seasons, the maximum of all of which, with a given outlay, it is the particular business of the engineer to provide. Thus not only does the expected traffic depend on the number of the population and its ability to pay for using a railway, but also on the inducements offered to use it frequently. Were railways only to be used for the purpose of trade and the acquisition of wealth, instead of also life and health, they would but half fulfil their objects. Wealth can of itself produce little pleasure to other than misers—and their number is fortunately limited—and most people view riches as a means to comfort and enjoyment. Assuredly no way commends itself to us of getting rid of the surplus rewards of previous labor so much as that which enables us to enjoy other scenes without going through severe bodily fatigue!

Anyhow this view, which has apparently induced the construction of a railway up a mountain with a total rise of 3,900 feet in three miles, solely with the object of providing 40,000 tourists with an easy ascent to the top of the *Rigi* on the Lake of Lucerne, seems justified by the results.

Here was no large traffic to count on; there was a good road up which the youth and beauty of Europe and America were wont to spring, with the elasticity of spirit engendered by the charming climate; yet, though the road is no less useful than before, the carriages of the Rigi Railway are crowded to an extent that would make an Indian Traffic Manager's heart rejoice. The inducement is entirely the novelty of the sensation

the luxury of seeing, with absolutely no trouble, the most magnificent scenery in Europe.

These are advantages for which the thousands of visitors to Lucerne are ready to pay, and to such good purpose, and with such ability have means been adapted to ends in the construction of the line, that a combination of both circumstances results in a return of twenty per cent. on the capital expended, though the railway is not worked for more than half the year.

These are facts which show that mountain railways are perfectly practicable, and that they may be applied with great success even to a very small traffic.

The principle of the *ladder rail* is to apply direct pressure of the engine through cogs on an iron ladder rail to effect the propulsion of trains, instead of by friction of the engine wheels on the rails. There is a limit of steepness beyond which an engine could not retain a grip on an incline by mere friction. It is variously stated by different authorities at from 1 in 4 to 1 in 7. But in practice inclines worked by locomotives are very much flatter than this, for if they were not, the load they could take would be excessively small. But the flattening of gradients which is equivalent to increase of the power of engines is effected only with expense in proportion, while the quantity of traffic may neither be so large as to require great power, or warrant a great expense.

In this way it is expedient to seek for a situation for a mountain railway to take a small traffic, where, though the grade may be as steep as possible, the amount of blasting, tunnelling, and bridging will be a minimum.

This is what has been done on the Rigi Mountain, which, with the exception of a little cutting and a bridge necessary near the foot, presents a surface with an almost continual incline of 1 in 4, on which to lay the permanent way, with a moderate amount of formation and ballast.

The line so laid out has cost £26,000 a mile, and is three miles long, giving a total of £78,000 for the capital. The profits are said to have been last year (1873) 20 per cent., or £15,600.

This amount was received from 100,000 passengers, giving  $\cdot 156\text{£}$  per passenger, or about 8s.  $1\frac{1}{2}d$ . As nearly as can be remembered, the fare charged was 7 francs for the ascent and 4 for the descent, or an average of  $5\frac{1}{2}$ , equal to 4s.  $4\frac{1}{2}d$ . The expense may therefore have been about 1s.  $8\frac{1}{2}d$ ., and the total working expenses £6,350. But many persons avail

themselves of the railway to go up who prefer the exercise of walking part of the way down, so that it is not easy to deduce accurately the expenses from the data available.

But as regards these expenses, we are able to from a pretty good guess, We know that the expenses of railways are almost invariably in the following proportion: Train Staff, 1; Station Staff, 1; Repair of Rolling Stock, 1; Renewal of Rails, 1; Maintenance of Sleepers and packing up the Road, 1; Fuel, 2; Stores and Labor connected with Trains and Stations, 1; Administration, 1; Miscellaneous, 1; Total 10.\* These *expense proportions* are independent of the gradients, but the *amount* of them will exactly vary with the gradients, and may be measured by the quantity of fuel expended in doing a given quantity of work.

The number of passengers using the line was 100,000, and 54 are contained in 1 train, giving 1852 train loads, which, distributed over 180 working days, would give about 10 trains, which, is probably the number of full ones that were run. The weight of them is made up of 15 tons for engine, 4 for carriage, and about 3 for passengers—total, 22 tons.

On the level it takes about one-seventh of a pound of fuel to take a ton over one mile, which is the same as raising a ton through 23·5 feet, reckoning the resistance at 10 lbs. per ton at a velocity of 15 miles an hour for ordinary trains. For a rise of 1,300 feet the quantity consumed would be 55 times as much, or 8 lbs. of good coal per ton moved one mile up the Rigi. But in descending no fuel would be required at all, so that per ton mile run, the expenditure would be 4 lbs. on the average of up and down. This would make the cost of working for fuel about  $27\frac{1}{2}$  times that of a ton over a mile of ordinary level line; all expenses would be in proportion. In India, a fare of  $\frac{3}{8}$  of a penny a mile is one which pays well for 3rd class passengers, the cost being about half that sum; the number of passengers per carriage is not so great as in the Rigi Railway, the dead weight may however be considered constant.  $27\frac{1}{2}$  times this amount ( $\frac{3}{16}d.$ ) would be  $5\cdot15d.$  per mile, or  $15\cdot45d.$  on the average for 'up' and 'down', or  $1s. 3\frac{1}{2}d.$ , which agrees with the expense deduced above; the receipts therefore being  $17\cdot58d.$  per mile, the expenses are about  $5\cdot15d.$

The large dividends are then clearly traceable to the high fares, which however are cheerfully paid by the tourists, and are, after all, only in keep-

\* See *Notes on Railways* by the author.

ing with hotel charges at the lakes ! It is advantageous to mention these circumstances, because it will show that mountain railways promise well even in situations where a less dividend than 20 per cent. can be counted on.

The economical capability of the single line, which is three miles long, for trains which work at three miles an hour, is 12 trains to the day's work. A train must consume 264 lbs. of fuel on the average per trip,\* which would amount to 1.414 tons a day, and for a complete year to 516 tons. The cost of the line was £78,000 complete, and for working expenses, to equal the rate of interest of money,† say 5 per cent., they must be £3,900 a year.‡ One-fifth of this will be for fuel, £780 ; it has been shown above that the quantity which can be most economically consumed is 516 tons, which would give the price of coal, including carriage on the Railway, at about £1-6-8 a ton.

The number of passengers with luggage, therefore, capable of being conveyed daily on a single line most economically, would be 324 in each direction, or 648 altogether, making 236,520 per annum.

Owing to the circumstances of the Rigi, which is essentially a sight-seeing line, trains running at every hour up and down would not answer the purpose, for visitors require to go up in the morning and return in the evening, and as they are all actuated by the same motives, the number of daily trains has to be crowded into shorter times towards morning and evening. It will suggest itself to engineers that this necessitates a good deal of 'empty' haulage and a larger stock of engines and vehicles than would otherwise be necessary, and this is in fact the case. Two engines would suffice for a regular traffic, whereas six or seven are to be seen in a day.§ The working expenses per passenger are largely increased by these causes.

It also becomes necessary to allow more than one train to be travelling between stations at a time, which appears to be done with little or no danger, when the nature and extent of the brake power available is understood.

As regards the applicability of these railways to India, it may be re-

\* 22 tons × 3 miles × 4 Rs. = 264 lbs.

† See *Notes on Railways*.

‡ It appears they were £4,360, which shows it was worked beyond its economical maximum.

§ This state of things would result in loss to the Company no doubt, but for the cause which prescribes its own cure. That is to say, the demand on the line enables higher rates to be charged to meet it.

marked, that it has at various times been proposed to locate all European troops in the Hills, and there seems no reason to doubt but what they would be specially useful in conveying the troops, followers, supplies, and stores up and down, and that the provision of such railways to approach our hill sanitarium would lead to their being much more resorted to than they now are by both Europeans and the upper class of natives. The lines could first be used for the transport of building material in the formation of the hill stations, and would not necessitate large outlays to provide a sufficient amount of accommodation for the residents afterwards.

Such a line as the Rigi Railway, affording access to an elevation of 3,900 feet, is shown to be made in Europe for £78,000, or £20 per foot of elevation. The interest and working expenses would not amount to more than £7,800 a year, and would provide for the movement of 648 men, or a reduced number with baggage, heavy stores, or materials, over it daily; the fare charged need not be higher than 10:30*d.* a mile to return 5 cent. on outlay. Every one knows that this would be an enormous saving in the present cost of ascending our Hill Stations with kit and kin.

It will of course be evident that a less abrupt rise in the gradient would enable more work to be done, but to attain the same elevation, a longer line would have to be constructed, and unless a reduced cost per mile for the less rise occurred, the whole height would be reached with a greater total expenditure. This expenditure might be justified owing to the larger traffic to be expected, and which the greater power resulting from the flatness of the grades would admit of being conveyed; accordingly every case ought to be worked out for itself; the smaller the traffic the steeper the gradients may be left, and *vice versa*.

Not to draw these remarks to a tedious length, the reader is referred to the admirable pamphlet and plates kindly furnished by the Company, which will explain the details of the construction which the author was unable to note on his hurried visit to Lucerne made in September last. To such as have seen the railway up the Rigi and feel interested in engineering works this article may supply some useful notes, while to such as have not, and who may be contemplating a run home *via* Brindisi on three months' short leave during the summer, it may act as an inducement to take Lucerne on the way, and in doing so, as it is certain such persons will have souls above pay and promotion, they will be fully re-



warded by a trip up the Rigi. It must not be omitted to mention that the author's acknowledgments are due to Mr. Maclean of the *Bombay Gazette* for the kind way in which he undertook to have the pamphlet translated from the German; also that the letter from the Company following the description of the railway has been printed, first, because it supplies some interesting details, and secondly, because it will enable any one seeking more information to obtain it by addressing the Company direct.\*

T. F. D.

\* Just as the revised proofs of the writer's pamphlet were being returned to the press, a description of the Rigi Railway turned up in the Minutes of Proceedings of the Institution of Civil Engineers, Vol. XXXVI., part 2, dated 1873, which enters into fuller details. At page 116 will be found statements confirmatory of the calculations of expense.

The number of trips up and down in 1872 was 2,875, or 16 per day, and number of miles run 8,920, giving 3.1 miles for the length of the line. The number of passengers, both ways included, was 87,000. Gross receipts £15,105, expenses £3,420, not including £3,000 carried to reserve fund. The receipts and expenses per passenger per mile, if they had all travelled the whole length, would be therefore 18.6d., and 3.04d., the latter not including contribution to reserve fund for repairs of way, &c. The receipts are less than shown by the calculations for 1873, and the line appears to be 3.3 per cent. longer than assumed (8 miles). The cost of the line is stated to have been £80,000, and the number of passengers 87,000, the former figures being 77 per cent. and the latter 87 per cent. of those given in the pamphlet. It is probable that M. Riggenschach only gave approximate figures in his letter below, but it seems some portion of the Railway is being doubled and the traffic is increasing. The figures given in the Institute Proceedings place the subject in a more favourable light, but considering the enhanced price of iron, and the cost of freight to India, it is probable that those appearing in this pamphlet will be more applicable to similar projects in this country. Anyhow they seem to be on the right side. Mr. J. Hawkshaw stated at the meeting that the Rigi Railway seemed on the whole, to display much constructive cleverness and to do great credit to its engineer.

## No. CXXVIII.

## CANTWELL'S LOCK TILES.

*Making, manner of Fixing, &c.*—This tile, with its modifications, can be made of clay and burned like pottery, or it can be made of sheet metal, such as galvanized sheet-iron or sheet zinc.

*Pottery Tiles.*—The Pottery Nurriah Tile can be moulded (which is the preferable method, as then exact uniformity is attained both in the thickness of the material and in the dimensions of the tile), or it can be turned on the potter's wheel, in the usual manner, to the requisite dimensions. After being turned, it is allowed to stand a little until it has attained a sufficient hardness to allow of its being easily handled; in order to give it a smooth surface and uniformity to its internal dimensions, it is then removed to another wheel, on which is *fixed* a mould in the shape of a *cone*. The tile is carefully pressed down over this mould until it has attained the requisite diameter, and any portion projecting over the top of the mould is cut away. It is then lifted off and allowed to dry a little, after which the tile maker will stand it on its large end, and, placing a strip of board slightly concave against the outside of the tile, he will draw a knife through it from within half an inch of the top to half an inch of the bottom, on either side of the strip of board, and then removing it, will smooth over the cuts, so that the tile may not warp in drying. After drying, the rejected portion is broken off, and the rough edges pared. It is then stacked and afterwards burned in the usual manner. However, for all practical purposes, it will be found that the common tile-makers all over India will mould these tiles of a sufficiently uniform size in the first

instance, and that the second operation on the fixed mould may be dispensed with. The Flat Lock Tile is moulded on a wedge-shaped mould having its sides bevelled, and made of sheet-iron or wood. The mould should not be removed from it until the tile has nearly dried.

In fixing these tiles on a roof, several systems may be adopted, suitable to the strength of the roofing timbers, and they can be laid on over a coating of plaster, thatch, or planking, or on a bamboo frame only.

The following figures drawn to a scale of 1 foot to 1 inch, represent the different forms of Lock Tiles used in the several systems.

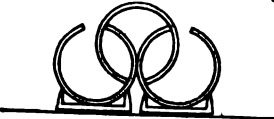
No. 1, is of the Horse-shoe, or Nurriah Tiles only, and is suitable for covering thatched dwellings and other buildings as a guard against fire.



No. 2, shows a double bed layer of Nurriah Tiles for roofs without thatch: should any of the tiles of the upper tier get broken by hail or otherwise, the lower tier will carry off any leakage.



No. 3, shows a bed layer of the old pan-tile, which is heavier and more substantial than the circular segment in No. 2, and answers the same purpose.



No. 4, is the Horse-Shoe and Flat Lock combined. It gives a handsome roof, but the flat tile is more liable to breakage than the other.



No. 5, is the Flat Lock Tile and the Nurriah reduced to a segment of a circle only, but having its sides clipped into lock. It is lighter than the full Nurriah, and consequently reduces the weight on a roof.



No. 6, is probably the cheapest and best arrangement, as it gives a freedom from all leakage, and its tiles would probably require re-adjusting only every fourth or fifth year. It will be seen that the roof would be formed wholly of Nurriah Tiles, but the locking portion is only two-thirds or three-



fourths of the circle, whilst the segment cut away (one-third or one-fourth is used in the manner shown in the section to form a double layer above and below.

No. 7 is the same as No. 6, but the upper segment is set in mud cement. (See shaded part). It is recommended that boiling water be used to mix the mud in order to kill the larvæ of white ants and other insects.



The eaves are fixed, either by having a weather board attached to the ends of the rafters, and projecting upwards for the tiles to rest against, or the ordinary eave tile can be used, and as an extra security against displacement by the wind, an iron wire should be passed along the whole length of the eaves, over the neck of the eave tiles, and this wire should be hitched down to the purlin, burgah, or rafter, at intervals of two or three feet, by soda water or other wire.

*The Ridges and Hips.*—The ridge and hip-caps are simply large tiles of the same form as the covering segment in No 5. They should be about  $1\frac{1}{2}$  feet in length and one foot across, and should be set in either mud or lime mortar, and if not coated altogether outside with lime mortar, the sides and joints should at least be pointed to prevent the wind forcing the rain in under them.

The following figures represent sections of Fan Ridge and Hip-Caps. Lengths, 15 to 18 inches; larger diameter, 12 inches; smaller do., 10 inches.

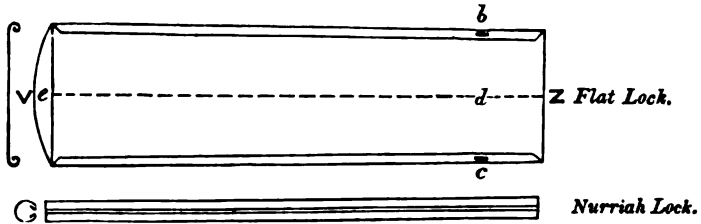


The Weight of these tiles will depend entirely on their thickness, but any ordinary roof will support five times the weight they can possibly attain. The angle of the roof should not be less than  $22\frac{1}{4}^{\circ}$ , but the tiles will stand at an angle of  $75^{\circ}$ .

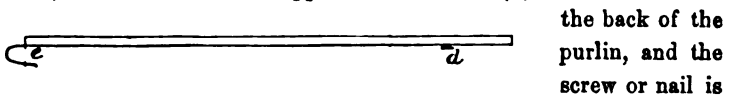
The Cost will vary in every part of India, but as a guide, where the ordinary semi-circular Nurriah, 12 to 14 inches in length, costs one rupee per thousand, these will cost Rs. 2 per 1000; and as it would take about seven hundred to cover one hundred superficial feet, the total cost, including fitting, fixing, &c., ought not to exceed Rs. 3 per hundred superficial feet. The cost of the flat lock tile would be twenty-five to fifty per cent.

over the cost of the old Grecian pan-tile, and the rate per one hundred superficial feet of roofing would be about the same as the Nurriah lock tiles.

*Sheet Metal Tile.*—When made of sheet metal, the length of both tiles



should be extended to about 6 feet,—the diameter of the Nurriah reduced to  $1\frac{1}{2}$  to 2 inches,—and the width of the flat lock tile should not be less than 12 inches. If laid over a sheeting of plank, plaster, or thatch, the turn-down piece (*e*) will not be required on the tile, and the width might be extended to 3 feet, which would economize material, but extra clips will have to be attached to the bottom of the tile intermediate between (*d*) and the outer edges, in order to prevent the centre from being lifted by the wind. Galvanized sheet-iron of a light gauge will be found suitable for the above purpose. For roofs without sheeting, the tiles will have to be fixed to the purlins or *burgahs*, but instead of fixing the screw or nail on the upper surface of the tile as is done with corrugated sheets and slates, an inch or so of the upper end of the tile (*e*) is bent down over



the back of the purlin, and the screw or nail is driven here, so that the upward pressure of the wind may not force the tile over the head of the screw. Should the purlins be of iron, then the back of the tile (*e*) would be bent over and clinched under it, and sheet metal of a heavier gauge should be used where there is no sheeting.

The principal advantage these tiles have over corrugated sheets is that they require no fixings, can be put up and taken down at pleasure, and again put up elsewhere, and will be as good at the end of years as the day they were first used, and that, once laid, they cannot by any possibility work loose or be displaced, except the whole roof be blown off bodily; whereas with the latter, screws, bolts, and battens are necessary to keep them on the roof, and eventually caulking to prevent leakage; and after all this is done, it is found from the contraction and expansion of wood

and iron that the screws work loose, the bolts get a little play, and the wind enters and either jerks the screw out of the wood, or wrenches the sheet over the head of the screw; leakage ensues, and repairs follow, to be repeated again after every high wind.

The ordinary galvanized corrugated iron sheet can be adapted for use with the lock tile by having its sides curved, as in the plain tile. But in order to counteract the excessive width of the corrugated sheet, and to prevent its bulging up in the centre, stop clips, a couple of inches in length, should be riveted or soldered to the under side of the sheet or tile. These clips will prevent the front of the sheet from being lifted by the wind, and will also effectually stop its slipping forward.

To obviate the use of these *stop clips*, a *grip clip* may be introduced, which is effected by turning-in, at the large end, a quarter to half an inch of the edge of the tile for whatever distance it is required that they should overlap. It is only *necessary* that this distance should be turned in, but it is desirable that the whole edge of the tile should be so turned, as it will give a greater longitudinal rigidity.

A pent roof building can be covered with these *grip clip* Nurriah Lock Tiles, without any roofing frame being used whatever—excepting king-post and tie-rod, each tier of tiles forming a self supporting cylindrical rafter—abutting on the wall plate and resting against the ridge piece. In any building where there is a central longitudinal wall, no king-posts are required, as the ends of the cylinder would rest on either wall. But if it be a long building, with no cross walls, tie-rods are recommended to be used, to counteract any thrust.

Five lengths, each 6 feet long, 4 to 6 inches diameter, 12 to 16 gauge with one-third overlap, will cover a span of 20 feet: another length might be added without any sagging taking place, which would extend the span to 24 feet. If economy of material is desired, then the lower tier only should be cylinders to answer the purpose of rafters—and the covering or capping layer tier might be of a lighter gauge, and have the same form as the cap segment in No. 5 Section.

When made to order, the Nurriah cylinder might be constructed in one length of a suitable gauge, and having the same diameter throughout, to 20, 30 or 40 feet, as might be required. With these single spanners each end resting on a wall, the roof might be almost flat, a slope of one in thirty sufficing to carry off the rainfall. Low parapet walls would be

built over each end of the spanner tiles, and the lower wall would have to be perforated opposite each tile to allow the escape of the rainfall. An inch or so of plaster terracing might be laid on over them after being fixed, which would exclude heat, and the pattering of rain and hail.

*The eaves* may be fixed with weather boards, or nozzles, a foot in length, may be used, and fixed to the eaves, and the next tile jammed into them.

*The Ridges and Hips.*—Five per cent. of half and quarter tiles should accompany every consignment of whole tiles, so as to allow of breaking joint and re-adjustment at ridge. When laid over thatch or plaster, the back part (*e*) of the flat lock tile next the ridge should be bent upwards and forward on each side of the roof, and the Nurriah ridge cap should be slid in over and grasping both Tiles. Another method is to use strips of sheet metal 6 or 8 feet in length by  $1\frac{1}{2}$  feet in width, to form a saddle; slits are made in the saddle opposite wherever the flat tiles adjoin, Nurriah caps are fixed across this to connect the ends of the Nurriahs on each side of the roof, and are pinned through. A third method, which is probably the cheapest and best, is to stopper the ridges and hips with a neatly laid ridge of lime and mortar or cement. When laid on over plank or on a wooden roof frame, the ridge caps are attached to a wooden side piece laid on over the ends of the tiles.

*The Weight* per foot will vary according to the gauge of the metal and the diameter of the Nurriahs, which can only be fairly determined by actual test.

*The Cost* of these Tiles will be found to be about the same, or something over, that of corrugated iron—according to the gauge used: and the manufacturer alone can estimate the cost per 100 superficial feet of the different systems and gauges.

---

#### *Specification of the Lock Tile System of Roofing Houses.*

This system is an invention whereby a roof can be covered with a sheeting of tiles without any nails, screws, or other fixings being used, except in the first tile at the eaves, and the last tile at the ridge, of the roof.

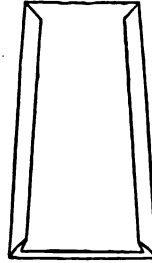
There are two descriptions of tiles used in this system, the "Nurriah Lock" and the "Flat Lock," which, on being placed on a roof, lock and interlock with each other.

The *Nurriah Lock* is the frustum of a *truncated cone*, open down the side, to allow of its passing over and locking the tiles beneath it.

The *Flat Lock Tile* is a modification of the Grecian tile, and can be

*Nurriah Lock or Horse Shoe.*

*Flat Lock or Grecian.*



used as a bed layer in conjunction with the Nurriah as a covering and locking layer. It is flat tile or sheet, narrower at one end than at the other, to allow of its passing into the tile in front of it, and having its sides curved upwards and inwards, so as to give the lock tile a holding.

The advantages claimed for this system of tiling are:—1st, No fixings required; 2nd, Not liable to displacement; 3rd, Every description of roof can be covered with them, such as thatch, plaster, shingle, or plank, or on purlins only; 4th, Not liable to damage from perforations in bolting, screwing, or rivetting; 5th, The Sheet Metal Nurriah, whether in compound lengths or in a single span, acts as a rafter from eaves to ridge, and is entirely self-supporting.

These tiles can be made of any suitable material, such as pottery-ware or sheet-metal, and of any dimensions, but the most convenient size is that specified in the foregoing description.

When made of sheet metal, either corrugated or plain, stop clips may be fixed to them as at *b, c, d*, (*vide p. 346*,) either by rivetting or soldering, the latter preferable. But if a quarter of an inch or so of the edges of both tiles be turned in, either for the whole or a part of their length, it will form a complete *grip clip*, which will entirely obviate the use of the *stop clips*, except at (*d*) and intermediate between (*d*) and the sides, when the flat lock tile is over one, or one and a half, feet in width. When no sheeting is used, and the tiles stretch from purlin to purlin, it is desirable



that the upper end be fixed. If the purlin be of wood, the part (*e*) should be bent down, and screwed or nailed to the back of it. But if of flat bar, angle, or "T" iron, it should be turned in and clenched under it.

The section of Nurriah Lock Tile, may be polygonal (*q*) or flat (*n*) or



an arc (*m*) or the complete circle (*p*). The latter is probably the best, where rigidity from ridge to eaves is required; but when economy of material is desired, the arc as at *m*, is the best.



---

 No. CXXIX.
 

---

 NOTES ON THE MULTAN INUNDATION CANALS.\*
 

---

 [Vide Plates LXXV., LXXVI and LXXVII.]
 

---

 SECOND PAPER.
 

---

 BY E. A. SIBOLD, ESQ., *Exec. Engineer.*


---

The different kinds of irrigation on these canals may be classed as follows:—

- (a). *Jhullar or lift irrigation.*—This is employed near the heads of canals where the bed is 12 to 14 feet below the natural surface, and the depth of water varies from 3 to 10 feet. The spring and canal level are about the same here, yet the cultivators apparently find it cheaper to pay the canal taxes than to sink a kutchra well with a wattled steining.
- (b). *Lift irrigation* when the rivers are rising and falling, and *flow* while they continue high. This affects the middle reach of the canal where the extra depth due to flood is eagerly utilised; thus practically passing on to the tail an uniform depth during the working season.
- (c). *Flow for autumn crops.*
- (d). *Flow for spring crops.*
- (e). *Swamping low land* in the working season, so that sufficient moisture is retained to mature the Rabi crops without further assistance. The low land in which the Khadil canal terminates, is a swamp from June to October.

\* Vide Paper No. CII., "Professional Papers on Indian Engineering," Second Series.  
VOL. III.—SECOND SERIES.

A well exclusive of gearing, costs from Rs. 100 to Rs. 200. The gearing of a Jhullar costs from Rs. 15 to Rs. 30, but though more economical than the well, still it requires four pairs of bullocks to work it, and since the rainfall is scanty, all the food for animal power may be considered as so much deducted from the gross produce. The late Colonel Anderson proposed, that where wells supplemented canals, eight acres for each well should be allowed free of water tax as a compensation for expenses, in order to encourage the mixed system as a partial relief in the event of an accident cutting off the canal supply.

The settlement is based on the assumption that the whole of the cultivated tract belongs to village communities. In many cases the village exists in name only, being represented by a convenient cluster of estates. The cultivated area is divided into "*chuks*" and "*sailabas*;" a *chuk* contains a well, and is seldom more than 25 or 30 acres in area; a *sailaba* is a tract of any extent entirely dependent on a canal, or on inundation of the river. The cultivators of a *chuk* live at the well, and not in their village, so that where there are no *sailabas*, there are no villages. The *sailabas* are being converted into *chuks*, as the owners save money enough to sink wells. A river *sailaba* may be swept away, or silted up above flood level. The officials make rough yearly measurement of such tracts, and the assessment being light, and the area inconsiderable, an approximation suffices.\* The few thousand acres irrigated solely by wells are the easiest to settle, because apart from damage by blight or locusts, the out-turn is the same year after year. Such cultivation is, however, so unremunerative, that the assessment is nominal. As for the bulk of the land, the lumping together of the land and water rates by the settlement, raised a difficulty. Government waste lands were afterwards let out at nominal rates, and the holders of such plots were able to draw cultivators from land owners who had both water and land rates to pay. Luckily such sales of waste land were discontinued before some of the more costly canals had suffered to any serious extent. It will be seen from the above, that all but a fraction of the land revenue is dependent on the proper

\* The objection to sale of water by bulk, is that no one system applies to every case. The Settlement Officers have solved a similar difficulty in the case of the vagaries of the rivers. In this case, neither the small percentage of land subject to alluvion or diluvion, nor the yield of revenue would justify a more accurate and vexatious style of working. This plan of giving up the farthing to save the penny of the postage, is doubtless liable to abuse. At the same time it may be better to incur the chances of abuse, to attempt at precision where the accuracy is in the paper work, and not in the field work.

working of the canals, but on such canals there must be a wide margin for accidents to prevent defalcations, or the alternative, indebtedness of the zemindars. Mr. Davies, Settlement Officer of Gurgaon, proposed that the bulk of the land revenue for canal irrigated tracts, should be taken in the shape of a water tax. Unfortunately the village lands of Multán were assessed at a fixed yearly sum. To secure the assessed land against any changes in the irrigation, bulky registers were prepared, giving widths, depths, and lengths of the smallest water-course. Such registers are obviously useless for rude and unregulated works, but a more serious objection is, that they obstruct the extension of the irrigation without effecting the object for which they were framed. The Multán canals show that where there is strict law, the *chuks* and small estates should be as far as possible independent of each other for their water supply. The share system when a number are concerned, whether worked by the hour, by area irrigated, or by fractional shares in the stream of water, give rise to too many disputes. Where irrigation is introduced into new country, a carefulness in granting water rights, though at the time apparently obstructive caution, will probably avoid future complication. It has been only lately settled, that the right to irrigate goes with the land for which it was originally granted.

At the time of settlement, it was arranged that the irrigators of each canal should provide from 30 to 650 labourers according to the size of the canal. These labourers work from the 16th December to the 15th April. Should the ordinary clearances be completed within the 90 days, the men are employed on improvements, cutting down spoil banks, &c. If not, the men have to work on till they are completed, and are also bound to attend for repairs at any time. These statute labourers are provided at the expense of the irrigator, the poorer generally coming themselves, and the richer providing substitutes. Powindas from across the border flock to this kind of work in the cold weather. The fine for non-attendance was formerly 4 annas per man per day; it has lately been raised to 8 annas. On each canal, according to its size, there are 3, 5, 7, 9 or 11 Moonsiffs or Assessors, selected from among the chief men. They have duties similar to those of Zillahdars on British made canals. Being land-owners, they are pecuniarily interested in their canals, and can be depended upon to give timely warning of, and assistance in, any disaster. They are remunerated by being remitted two statute labourers, money value about Rs.

90 per annum. The post is much sought after, less for the remuneration, than for the influence it gives its holders. In August the Moonsiffs ride round the canal irrigation, and divide rateably among the villages concerned the statute labourers to be called out. These *Mouzawar* or village assessments are usually accurate, as each Moonsiff is interested in seeing justice done to his circle of villages. Disputes between Moonsiffs about the assessments are decided by the Executive Engineer, but they are rare. In October, Moharrirs or writers take out the lists to the village headmen, who apportion the number they are called upon to provide *asamiwar*, i. e., to individual irrigators. In some parts of the district, the petitions against the *asamiwar* assessment are numerous, most so where there are wealthy Hindus. The assessment is usually based on out-turn and description of crops. In all disputes it is best to decide by area and description of crops, as it is difficult to estimate out-turn from oral evidence. In assessing description of crop, 3 acres of indigo are considered equal to 54 acres of jowar, and 8 of wheat, and so on. The *asamiwar* assessment entails fractions. The statute labourer is called a *seer*, and is divided into 16 chittacks, so that when an estate has to supply 4 chittacks, it means that it has to send a labourer every fourth day. Where the fraction is small, and the distance to the work great, the assessed naturally prefer paying the absentee fine. These fines are credited to what is called the *zarnagha* fund, which provides assistance in cases where the loss is so great, that the irrigators are not able to repair or remake their canal, and also defrays the cost of the Government establishment. It is practically an insurance fund. The chief merit of this system is, that it enables a large amount of work to be done with a very small supervising establishment. The work has to be done, and if there is speculation, the irrigators suffer, and not the Government, which though not a perfect, is a powerful check on malpractices. All disputes between irrigators concerning their individual objections to contribute labor, are adjusted, not as between Government and irrigators, but as between one irrigator and another. The system works admirably, and might be found useful on small irrigation works.

In all earthwork, the labourers cast up by stages. However long the lead may be they never use baskets, but in exceptional cases they will use a sort of tray which is carried by two men. In the silt clearances, rectangles sufficient for a day's work are marked off in the silted bed, and gangs (varying in strength according to lead and lift) are put on each.

On the 10th January, 1872, I inspected the statute labourers at work on the Gazahata canal. It was worth seeing the 164 men ranged in 7 rows on the canal slope, throwing the silt one to the other with the precision of an excavating machine. There may be a waste of power in throwing stuff in this way from one to the other, but the precision and rapidity of work is admirable. The arrangement was such, that a single man could detect at a glance if any man was skulking. The men work from sunrise to sunset, and in one case I found that the out-turn per man per day, was 142 cubic feet with a 16 feet lift, and 120 feet lead. There were 9 men in a gang, so that each cast to the other about 1,278 feet.

In addition to assessing the statute labourers, the Moonsiffs attend at the silt clearances in turn, and certify to the correctness of the register of attendance; they also give assistance in the management of the irrigation. Besides these, there are *Mirabs* or Canal Police, elected by the irrigators and paid in kind. The *Mirab* on the Khadil canal which supplies 86 wells, receive from each 5 seers of either rice or cheena for kharif, value Rs. 10-12-0, and 7 seers of wheat or other grain for rabi, Rs. 30-0-0, which gives a total of Rs. 40-12 per year; but on the Matihal canal, where there were 300 wells and cotton largely sown, the income of the *Mirab* was about Rs. 150 per year. The *Mirab* system has this advantage, that being one of the people, the man elected cannot be so unscrupulous as an outsider, and dismissal is a life long reproach to him.

The cost of irrigation varies considerably on the different canals. It is sometimes very burdensome. In very bad cases, the men would have to abandon the canal and their lands, and seek a livelihood elsewhere, if not given assistance from the Zarnagha. The cultivators are as a rule hardy, energetic, and manly, and the canal officer who possesses tact and forbearance, has little difficulty in winning their confidence and esteem. His canal improvements are so readily and warmly appreciated, that he can scarcely help feeling himself enthusiastic in his work, and he requires to exercise all his conservative feelings to restrain himself from altering too much at one time. Identified as he is so intimately with the agricultural prosperity and very life of the people, and brought into such frequent contact with them, the canal officer is the one to whom in failure of crops the people naturally look to for counsel, for assistance, and for relief. The Laugreals, near Mylsi on the Sutlej, once noted cattle lifters, are now contented and industrious agriculturists. It is, however, a seri-

ous matter to develop irrigation in a rainless tract, where a collapse of irrigation works may cause an amount of suffering as disastrous as the Orissa famine.

The great item of expenditure on these canals is earthwork, whether in the shape of silt clearances, or in excavating new heads. As the canals have existed long before any other works, bridges are built at the expense of the roads requiring them; other masonry works by the individuals interested. Taking the value of *cher* labor at six annas per day per man, the cost of silt clearance varies on different canals from eight annas to Rs. 3 per acre. The higher rate is reached on badly aligned and *small canals*, and it is an average rate struck over the whole area watered, whether once or several times. It will be found that where the irrigation rises to Rs. 3 per acre, the whole length of canal and all the branches require annual extensive clearances, and that these are merely long narrow settling tanks communicating with the river. Obviously the only satisfactory remedy is to accept silted bed as true level, and to seek a new head high enough up to cover difference of level.

In 1854 the charges were as follows:—

*Sutlej Canals.*

	RS.
Statute labour, @ Rs. 0-2-6 per man, ... ..	63,080
Revenue fixed in 1850, ... ..	2,45,439
or 25 per cent. of canal land revenue.	

*Chenab Canals.*

Statute labour, @ Rs. 0-2-6 per man, ... ..	16,469
Revenue fixed in 1850, ... ..	2,15,682
or 8 per cent. of canal land revenue.	

The cause of this difference in cost of maintenance is owing to the Chenab canal heads being more stable, and to the cultivation of more valuable crops on its banks. The canal land revenue has remained about the same, and the cultivation has not been much extended, whereas now the value of statute labour is equal to 6 annas per man. The value of produce has risen, owing to better means of exporting the surplus, and greater demand from Sind, but compared with other charges, the cost of irrigation has increased.

Among the number who have a lien on the soil, it has never yet been settled who is the proper person to make an application to cut a water-course. In a case in the village of Luftabad, it was alleged that the

Nawab, who objected to his hereditary tenants application for irrigation rights, did so with the object of ousting them for the purpose of getting tenants-at-will. Attempts are sometimes made by men who do not own land, to cut channels as a speculation, trusting to the sale of water to recoup themselves, and many irrigators make considerable profit by selling water. In all sanctions to irrigate, the estate for which sanction is granted should be very carefully specified, as this is more important than the names of applicants. In the case of lands regularly settled, numbered and registered, this is not difficult. The *chuks* are so admirably defined, that there is no trouble with them. With *sailabas*, since they are undefined, it is not so. To sanction a man's application to irrigate a *sailaba*, is to permit him to irrigate an unlimited tract, which gives rise to endless litigation.

In dividing cost of maintenance, the shares in the Mula Mallickwala Kassi were arranged as follows:—

						RS.	AS.	P.
Moolchund,	...	...	...	...	...	0	9	0
Dabee Dass,	...	...	...	...	...	0	2	0
Mula,	...	...	...	...	...	0	1	3
Babo,	...	...	...	...	...	0	0	3
Kashi,	...	...	...	...	...	0	0	3
Faiz Bux,	...	...	...	...	...	0	2	6
Sham Dass,	...	...	...	...	...	0	0	9
Total,						1	0	0

It is not politic to allow a distributary to become private property, and as far as possible, private channels should not supply more than two or three estates. This can only be enforced satisfactorily in high level irrigation. The lax system of Native Government gave individuals rights, that under sharply defined British Law seriously interfere with the management. No private water-course should be more than one mile, or at the most two miles long, and it should have no branches to irrigate lands not in its immediate vicinity. As far as possible it should only irrigate the lands it actually traverses. One shareholder elected by the rest should be held responsible for its maintenance. There is a very large amount of case work on these canals, and sanctions for the most trivial alterations or additions have to be applied for, and a regular record made, and a notice posted in the village concerned, calling on all who wish to object, to state their objections. On the Bari Doab canal, a man is left to do what he likes on his own lands. The former procedure has some merits.

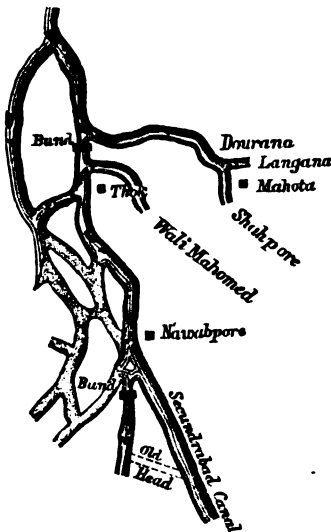


The present head of the Matihal canal is 26 feet wide, and the declivity 1 in 10,000 as far as Belochwala; beyond that it strikes into the high land abruptly, *vide Plate LXXV.*, and practically has no declivity at all. Levels in 1871 showed that the head and tail were on the same level, the take-off being the sole cause of its working. Its Binda head which was abandoned in 1870, was 20 feet wide, its Jamalki head, abandoned years ago, 12 feet. The area irrigated (from 2,200 to 3,400 acres) is paltry compared with its present dimensions and costly silt clearances. Between Salurwahan and Belochwala, the canal traverses a low country, which was annually inundated by the floods spilling over at Mamdal before the bund was made. The cultivators in maintaining this canal, pay a high price for getting irrigation in a shape more manageable and certain.

*The Khadil canal.*—Its mean width at head is 16 feet. It tails into a bit of low land, extending for miles between Mardapore and Sangee. On the skirts of the lake so formed, rice is grown in the autumn, and the land submerged till October bears spring crops.

The *Shahpore* about 4 miles below Mahota, runs out above soil, and

Fig. 1.  
Rough Sketch of Canal Heads in 1872.



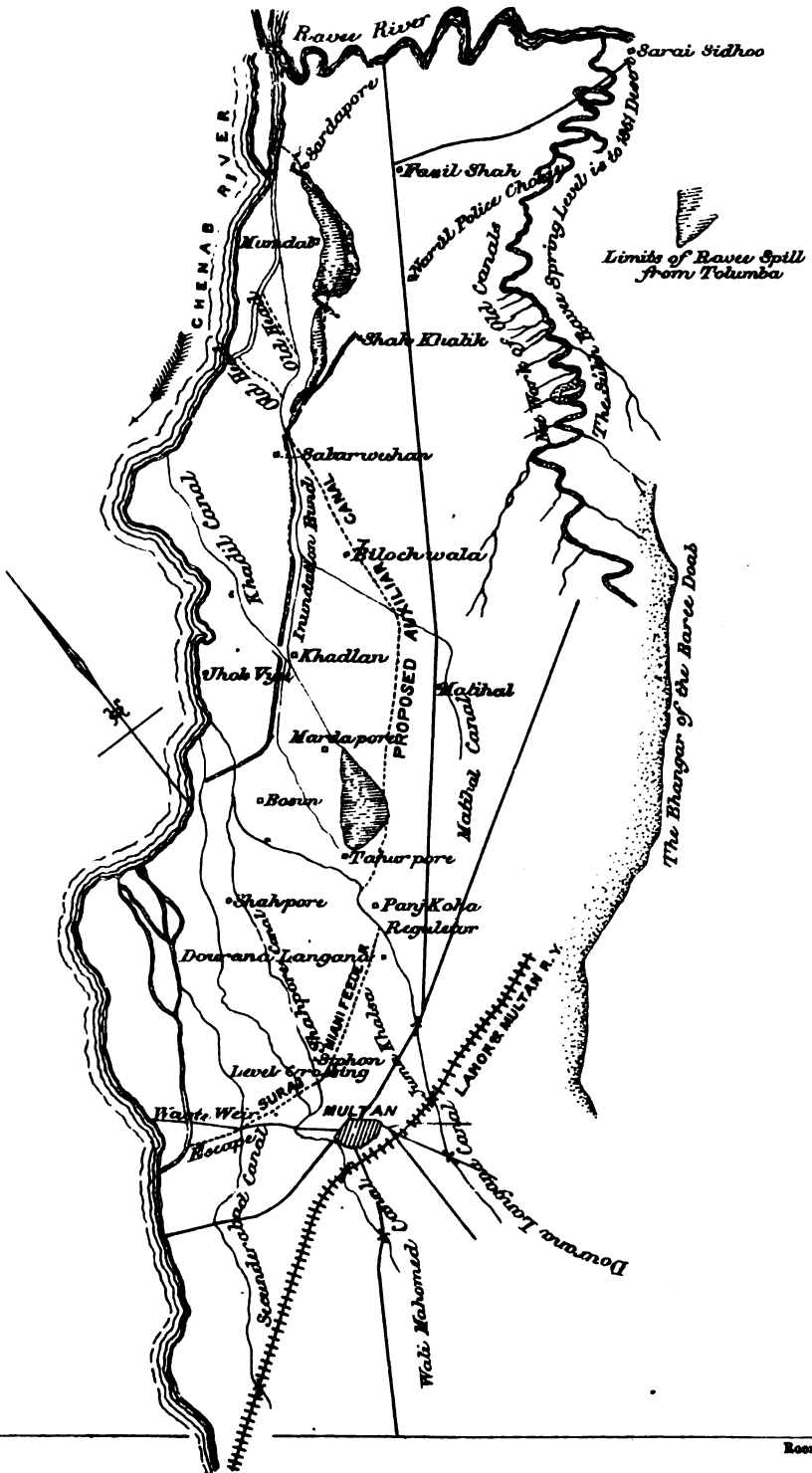
from thence to Multán, it commands a compact and highly cultivated plot. Owing to its high level, it has no costly and troublesome private cuts. Below the fork the bed does not silt, but the discharge is impeded by projecting Jhullars, tufts of grass, and roots of trees. The bund shown at the head (*Fig. 1*), was successful in maintaining a good supply. The labourers are very ingenious in plating the exposed slopes with *jou* jungle, and so making the bund very substantial.

The *Dourana Langana* was formerly only a water-course from the Shahpore, but gradual alterations have now made it the principal chan-

nel. To protect Multán from inundation from the river and from the

SKETCH MAP OF THE UPPER CHENAB CANALS.

Scale, 6 miles = 1 inch.

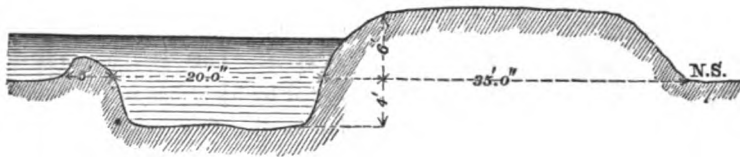




"Bar," its right bank was made from 30 to 40 feet wide, and 4 to 8 feet high, and it was extended for 20 miles to the *Sukh Beas*. After working for the season of 1871, no silt could be found on its bed. It suffered from its banks sliding in. This was remedied by cutting down and counter-sloping them. Its longitudinal slope is nearly 1.0 foot per mile, its width at head 20 feet, and the depth of water varies from 1 to 3 feet. In July

Fig. 2.

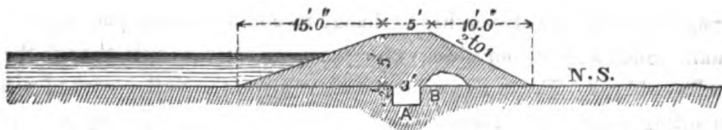
*Cross Section Dourana Langana at Panjkoha.*



1872, the greatest flood known for years came down from the high land, cutting up about 7 miles of the Railway near Tatipore, and stopping the traffic. The Dourana Langana drained this off to the *Sukh Beas* in about seven days. The water never rose higher than 4.0 feet above natural surface on the bund, yet it managed to percolate through the 30 to 40 feet of bank, even where there was only 1.0 foot head of water, and the bund has had years to consolidate. This was owing to the earth for the bund being simply thrown on the natural surface. Percolation can be easily prevented by digging a trench A along centre line of bund, Fig.

Fig. 3.

*Water tight Section.*

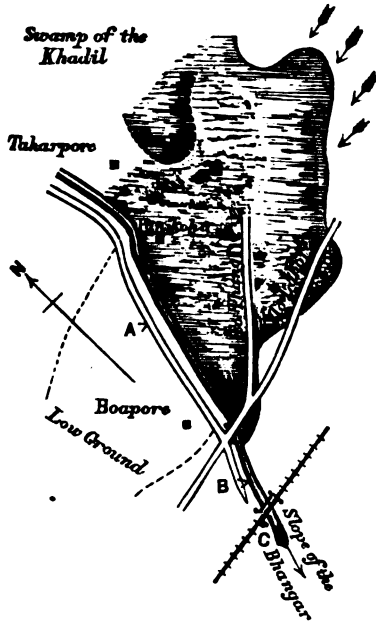


3, and using the stuff obtained from it as a footing B for the new earth.

This flood was similar to one that occurred at the 6th mile of the *Sirhind* canal in July 1873. Between the 5th and 8th miles there was about three square miles of drainage to be passed over the cutting, temporarily, and the wooden aqueduct (8 feet  $\times$  4 feet) was placed at the lowest point;

as at A in Fig. 4). Rain commenced at 4 A.M. and at 6 A.M. the aqueduct was swept away, and the flood water poured into the cutting.  $3\frac{1}{2}$  in. fell

*Fig. 4.*  
Flood water from the Bhangar from heavy rain on the 22nd July, 1872.



in four hours, and the discharge lasted eleven hours. The discharge at 8 o'clock was certainly not less than 720 cubic feet per second.

After this accident, the drainage was crossed over the canal about 600 feet away (as at B or C) through high ground, but the bed of the crossing was kept at the same level as at A. This diversion was not tested by  $3\frac{1}{2}$  inches in four hours, but as the flow with the same rainfall in twice the time was quite insignificant, it proves the efficacy of not putting the drainage crossing in the lowest part. The greater the length of confined channel between ponded flood and opening, the less the fluctuations of the flood affect the latter.

The *Wali Mahomed* is the most ancient and finest canal in the Multán district. It has 14 "*Lars*" or raj-bahas, aggregating in length 96 miles. Each of these *Lars* supplies from 20 to 80 wells. After working for the monsoon of 1871, examination showed that the silting was not much for the first 5 miles; for the next 17 nothing; and, of course, at the tail considerable. It will be seen from Fig. 1, page 358, that the stream has to change its course twice in passing to the canal. Such a feed from a backwater generally answers well, though there is a loss of head. The same year the Sirdarwah on the Sutlej worked without silting at all. The mean velocity on the first class canals appears sufficient to carry the silt down to the tail, and with good distributaries even on to the land. In the middle reach of the *Wali Mahomed* canal, the irrigators have the right by virtue of the settlement to use the "*Tad*."\* As the reduced level of this was not ascertained at the settlement, the disputes during the clearances can never be adjusted one way or the other.

\* See list of terms at end.

The *Secundrabad canal* is next in importance to the Wali Mahomed. It is a drawback on inundation canals, that their carrying powers are much in excess of their requirements. If fed from a higher level, a 16 mile length of this canal is capable of carrying enough water to supply the whole of the lower Chenab canals. Near Mozafferabad, slight and harmless retrogression of level was distinctly perceptible in October, 1871. This was not due to the flooring of the Railway bridge being too high, as the bed for a long way up-stream was scoured clean. It takes out from the river at about an angle of  $20^{\circ}$ , and for 5 or 6 miles below Nawabpore, the silt runs from 3 feet to nothing; below that, clearance of irregularities only is required. *Fig. 1*, page 358, shows how this canal derives its supply from the river. The channels marked by arrows fill as soon as the river rises, whereas the others only work in flood, and are therefore useful as waste weirs.

The *Inundation Bund*.—This runs from Shahkhalik to the Wali Mahomed canal. In some places it is 10 feet wide: in others 5 feet; its river slopes are 3 to 1. No where is it higher than 8 feet, and its average height is 4 to 5 feet. Its weakest point is just above Salarwahan, where the Mamdal spill of the Chenab gets into a *cul de sac*, as *Plate LXXV*. shows. It has been breached several times here, but in other parts it has served its object, that of protecting Multán, admirably. It is nothing compared as with the huge bunds on the Indus for the protection of Dehra Ghazee Khan. The careful and minute survey made for it, has been most useful in ascertaining the style of country the upper Chenab canals traverse.

*Joint Stock canals*.—To make irrigation successful, the man in charge must have authority to settle all disputes on the spot. In one case only, among several, has private enterprise been successful. In this case the owner of the canal, Rais Gholam Khadir Khan, is a great landed proprietor, and owns all the lands his canal traverses. The Mahomedan laws of inheritance will ruin this canal. At his death, there will be litigation, and pending settlement, the canal will collapse for want of maintenance. The following instances will show that the people are aware of the complications that arise in such cases. The proposed Faridkay canal which was to take out 6 miles above Tolumba, and run to Khanawala, was estimated to cost Rs. 20,000. A number of landowners volunteered to deposit this amount in the treasury, provided it was made and managed by the Irrigation Department. They stipulated that during the first four years of its working, any outsider should have to pay a specified sum as a com-

pensation to the original promoters of the canal, but that after four years, Government should have the right to manage it like the rest of its canals. They calculated on deriving so much benefit from it in this space of time, that it would be worth their while to hold out this inducement to Government to take it up. Tempting as the scheme was, the chances of litigation prevented them from undertaking it directly themselves. The second canal was to take out from Nasratpore on the right bank of the Ravee, and to be 26 miles long. Each village was to dig the portion that ran through its own boundaries; the poorer ones being assisted by advances from Government. One man, Mehr Shah of Korunga, was willing to dig the whole of this canal himself. This was inexpedient, as difficulties crop up afterwards when private parties dig canals, *e. g.*, Gholam Khalir Khan, wanted Rs. 2,00,000 when the question was mooted of buying him out, though it had cost him but Rs. 18,000.

*Bench-marks and bed levels.*—Reliable bench-marks and bed levels are important aids in the management of irrigation. A bench-mark is only valuable when it can be easily found, and the portion which gives the level is reasonably safe from injury. It is a good plan to have a platform flush with the natural surface with two places on it, say North and South, carefully cut to the same level. On it should be built a pillar, the shape and size of which is immaterial, so long as it can be easily seen. The levels should be given by cut clinker bricks, or a through slab of stone kept in position by the pillar. As square edges are easily injured, all edges above ground should be rounded off. For bed levels, lines of stakes across the bed at intervals of 1,000 feet have been tried, both on these canals, and the rajbuhas of the Bari Doab canal without success. The causes of failure are due to the difficulty of finding them again in a silted bed, and to their being easily displaced. If such marks are considered really necessary, it would appear most economical to put in masonry bars with the flanks built above full supply. The zero for reduced distances on inundation canals, should be some distance from the canal head.

*Surveys.*—In flat desert country, only levels are required, but for re-plotting a network, or picturing difficult country, the plane table gives a map, beside which a traverse is an unsatisfactory skeleton. It is strange that the plane table is rarely used in canal surveys. Trained men can sketch in a great deal of information, that can scarcely be obtained by the cumbrous method of off-sets crowded into a field-book.

In the Khadirs of the Panjab rivers, having settled how the irrigation is to be provided for permanently, temporary and local expedients may be

brought into play for developing it in the commencement. In canals, like the Bari Doab and the Sirhind, the headworks and trunk lines must be made of the required dimensions at the outset. In the Khadir canals, excavations not exceeding twelve feet, and primitive bridges, represent the cost of trunk lines. The great drawback of the Imperial canals that traverse the Bhangars is, that capital is locked up for so long a time, and even when the work is completed, there is not a population sufficient to utilise the whole stream at once. The time required to test the financial success of canals on the Bhangar, is too long for the comparatively short-lived administrations which have to sanction them. For instance, the Shahpore and Bhawalpore canals are examples of what can be done with barely rudimentary ideas of engineering. In some cases an energetic civil officer would probably show marvellous results in irrigation, and the engineer would be out of place, whereas in others, the former would certainly fail. In local works of improvement, Engineering is often thought obstructive, because present success appears to confute its warnings of future possible disaster. The proposed *Auxiliary canal* (*vide Plute LXXV.*) would really feed from the Ravee, and owing to the arrangement of the sand-banks at the junction of the two rivers, it would reach Salarwahan with a much greater command of the country than the Matihal, though not taking out much higher up. The long existence of the Mandal lake, proves that this superiority of level has existed for a very long time.

The Mandal lake is supplied by—

- (1). Cuts from the river.
- (2). Spill of flood water.
- (3). Drainage from the Rawan for ten miles inland.

The high level of the lake is preserved by a bund a little to the north of Shakhhalik. In a case of this sort, there is some disadvantage in working with the people. In all improvements there must be drawbacks, but it is hard to convince a people, who think the Government can do every thing, that the drawbacks due to losses in the Kharif by cutting the bund, are compensated for by gains in the Rabi. They see in a way the bearings of the case, but the people have a child-like faith in the idea that Government is willing to compensate with or without cause. Some of the chief men, like Rais Hyder Shah of Salarwahan, have also lands much further down, and if the project was worked through them, no discontent would arise. The canal would cut through a tongue of land higher than the highest flood level near Sardapore, so that in the absence of a regula-



tor, flood waters would still be under some control; and again near Shahkhalik, the confined channel feeding from the lake would still further regulate the supply.\*

From Salarwahan to Taharpore, it would run in a fairly straight line, and through low country, thus saving excavation. From Taharpore to its escape into the river, it would avoid the valuable lands adjacent to Multán city. It is also not necessary that the whole of this length should be completed before any returns are expected. The first length made as a fifteen feet or even ten feet channel, would be a useful feeder to the Matihal, and as it was extended, so it might be widened.

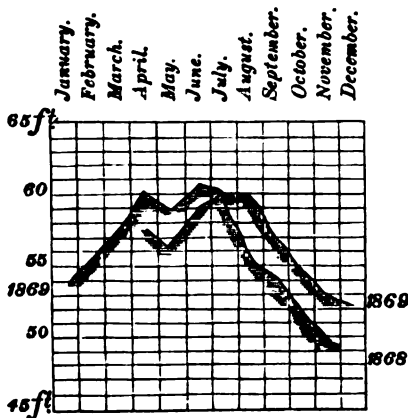
*Perennial supply.*—The Sultanwah and some other canals in the Bahawalpore State are perennial, which shows that there is no considerable difficulty in digging below the cold weather level. The greater declivities on the channel would enable a canal to get out of heavy digging sooner. A cut twenty miles long from the Sidnai reach of the Ravee, would make the auxiliary canal perennial, for the Ravee is never actually dry for more than a few weeks in December, and the following will show what a large discharge is given by a small increase of depth.

19th December, 1871, reading of gauge 0·63 discharge 26·10 c. ft. per second.  
 19th January, 1872, " " 2·20 " 1017·47 "

In the Sultanwah canal, the great depth of water in it when there is a flood, is soon dissipated over a large tract. If the head of the auxiliary canal was placed at bed level 41·0, (*Fig. 5.*) the greatest depth of water to be dealt with would be twenty feet, as the year 1869 was a maximum one. It would be easy to construct a culvert with the crown of the arch at such a height above canal bed, that the highest flood would never give more than a given depth, say ten feet in the canal. As an alternative, there might be a

*Fig. 5.*

*Gauge Diagram of the Chenab.*

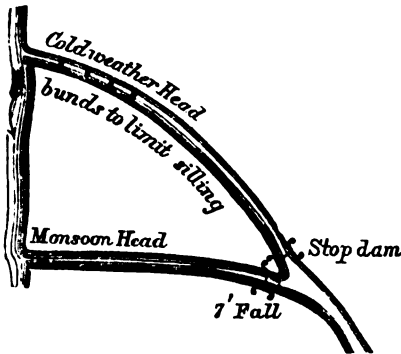


flood, is soon dissipated over a large tract. If the head of the auxiliary canal was placed at bed level 41·0, (*Fig. 5.*) the greatest depth of water to be dealt with would be twenty feet, as the year 1869 was a maximum one. It would be easy to construct a culvert with the crown of the arch at such a height above canal bed, that the highest flood would never give more than a given depth, say ten feet in the canal. As an alternative, there might be a

\* The lakes of Lombardy show how a large basin of water will control the violence of flood waters.

monsoon head with a fall into the canal proper, and a cold weather head closed up during the monsoons (*Fig. 6*).

*Fig. 6.*  
*Double Heads.*



The *Suraj-Miani Feeder*.—Several feeders of this description connecting the different canals would enable the small supplies of each canal when the river was low, to be thrown into one, and the high level to be thus preserved. This attempt at preservation of an uniform level at fixed times, however imperfect the success may be, is the most important point in irrigation management. In this case the feeder had to intersect

the Shahpore canal, as the lands in the suburbs of Multán were too valuable to be taken up.

*Earthwork*.—In Multán, a canal is more valuable than land. The Auxiliary canal as a feeder to the Matihal was started in September, 1872. The spoil was so arranged (*Fig. 7*) that it could year by year be

*Fig. 7.*  
*Cross Section of Auxiliary Canal.*



gradually widened to 110 feet at bed, and so gradually dispense with all but the best canal heads lower down. A four feet trench was first dug, simply to tap the spill water, and save some of the crops that were endangered by the wretched working of the Matihal head. It will be found that earth thrown to spoil with a triangular section stands weathering best, where the canal is in digging, the long slope should be to the outside to shed most of the rain water; where it is in embankment, the long slope should be the water slope, as it will quickly silt up and puddle itself.

*Regulator at Panjkoḥa.*—In designing regulators, care should be taken that on the up-stream there is no room for back water, and on the down-stream side, that the stream after passing the masonry should not have to spread out to fill the earthen channel. If the stream has to spread out, we have objectionable cross currents and eddies, and expensive protective works are required. The following appears a good rule for determining the angles and sides of the triangle ABC, (see Fig. 3, Plate LXXVI.)

Let  $b$  = width of bed of main line, and  $d$  = depth of water.

$$\begin{array}{l} b_1 = \quad \quad \quad \text{right branch} \quad \quad d_1 = \quad \quad \quad \\ b_2 = \quad \quad \quad \text{left} \quad \quad \quad \quad \quad \quad d_2 = \quad \quad \quad \end{array}$$

and

$$(b_1 \times d_1) + (b_2 \times d_2) = b \times d^2$$

where  $d = d_1 = 5.0$  feet, and  $d_2 = 4$  feet.

Therefore

$$b = \frac{125 + 64}{5} = 38 \text{ feet nearly,}$$

and  $AB = 38 + 2d = 48$  feet.

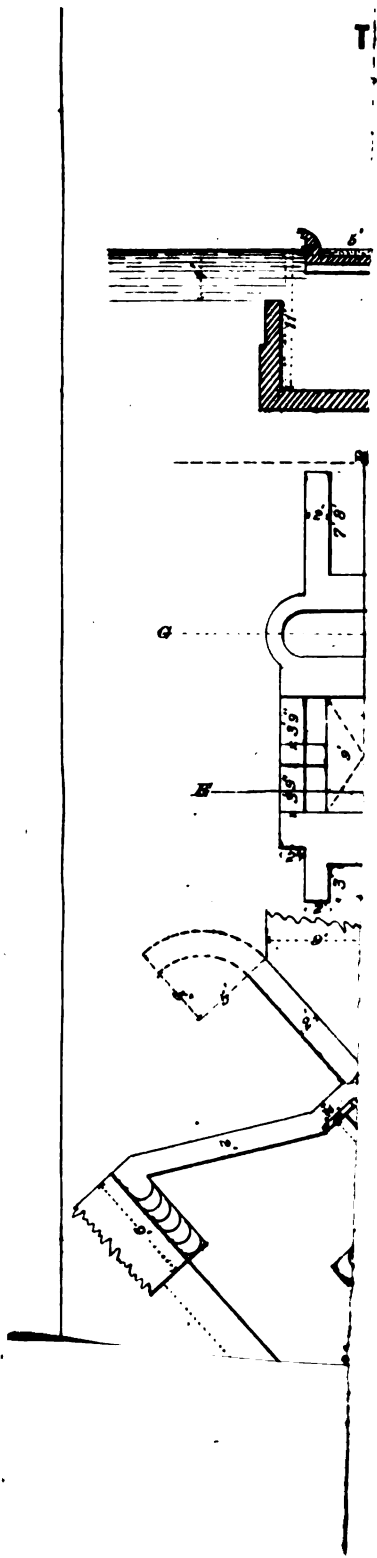
$$CE = CD = \frac{2d_1 \times 2d_2}{2} = 9.0 \text{ feet.}$$

$$AC = b_1 + 2d_1 + d_2 = 44 \text{ feet.}$$

*N.B.*—To obtain equal openings, AC is made 47 feet,  $BC = b_1 + 2d_1 + 9 = 37$  feet.

When  $AD = b + 2d$ , then the left branch should be designed as a rajbaha head, and built independently of the regulator. In that case, the rajbaha should take off at the most acute angle practicable. In masonry heads, the smallest feasible angle is one of  $45^\circ$  to the main line, and the rajbaha heads built at this angle work well.

*Syphons.*—In canal works, syphons are constantly required in the case of minor channels intersecting other channels or drainages. Where a rajbaha crosses a road, the maximum head of water would never exceed 3.0 feet, and in drainages, there is the alternative of passing the drainage under. But where the head of water is more than 3.0 feet, the ordinary brick culvert is out of the question, and the design, (Fig. 1, Plate LXXVI.) will be found an economical substitute. An objection that there are practical difficulties in the way of securing a water-tight fit, might be raised against this design. The present masonry syphons leak more or less, and if the planks were made to overlap, any leakage might be effectually stopped by the swelling of the wood. It is not safe in pressure to take





into account the cohesion of mortar. The weight of the brickwork should equal pressure of maximum column of water. Taking wet masonry at 120 lbs. per cubic foot, and water at 60 lbs., there should be a foot of masonry to every two feet of head of water. With the Suraj Miani feeder dry, and the Shahpore working with full supply, the head of pressure would be 11·25, and the requisite thickness of the arch of a brick syphon would be 6·0 feet. If the water is passing through at a considerable velocity, the statical pressure is somewhat diminished, and in practice the thickness given is somewhat less. This plan, however, with the aid of holdfasts, makes use of the weight of the whole of the masonry. The plan also gives facilities for clearing out a choked up syphon.

*Bridges.*—Most Engineers appear to object to the use of masonry in temporary works. An abandoned masonry work is certainly an eye-sore, whereas abandoned earthwork passes unnoticed. To carry out the idea of gradually widening the auxilliary canal as the irrigated area extended, if masonry works are used, they must be made capable of enlargement.

In the bridge built in the first mile of the Shahpore canal, (*Fig. 2, Plate LXXVII.*) there are no wing-walls, and if the canal is widened, all that is necessary is to add additional spans. Timber for these short spans is always to be had on the canal banks, and the nearest village carpenter can execute the repairs. In a climate so trying to timber, even temporary bridges should have masonry piers and short spans. Trusses are a mistake. On the Amritsar branch of the Bari Doab canal, a saving was effected without detriment to the limited traffic, by building bridges with only a 10 foot roadway. The late Col. Anderson designed all his masonry narrow road bridges on these canals, so as to utilise the wing-walls as counterforts for the abutments. (*Figs. 3 and 4*) are a modification of this plan.

*Falls.*—The depth of water at the tail of the Shahpore canal is from two to three feet, whereas in the Walli Mahomed into which it falls, it is from six to seven feet; when the supply of the latter fell, the former had to be bunded up. To avoid the mess caused to the channel, and to get the water under control, the fall shown in *Figs. 5 and 6* was built. To give the masonry a better hold on the banks, and to prevent percolation, the blocks AA were put in. The notch fall shown in *Fig. 7*, is better where a skilled mistrie is to be obtained.

*Waste weirs.*—With a channel of specified dimensions, and the depth of

the water that may be safely allowed to pass a given point settled, it is easy to determine, taking highest flood level, what should be the length of the weir. A rule of thumb way of calculating the length of weir is to take—

Discharge due to depth  $a = X$ .

” ”  $b = Y$ .

Then length of weir  $c = \frac{X-Y}{\text{Velocity due to height } (a-b)} \times 2$ .

The above saves a complicated series. The proposed waste weir was designed as shown in *Figs. 8 and 9*. When there was a high flood in the canal, the river would pond up in the escape, so that for such occasions, a plain wall would be sufficient, because with great depth of water on a weir, the stream passes over in a long wave, but the small spill is most to be feared, and to guard against the effects of such a spill, a small cistern is provided.

The following is a list of the principal terms used in irrigation in the Multán District.

*Zarnagha*.—From *zar*, gold or money, and *nagha* a blank or void, so it literally means payment for non-attendance.

*Mirab*.—Is literally master or chief of the water.

*Cher*.—A slave. The statute labourers are called *chers*.

*Nálá*.—Main canal.

*Lár*.—A branch of ditto.

*Kássi*.—A private water-course for one or more villages.

*Pággí*.—A branch of a *Kássi*.

*Túkha*.—A simple cut in a *Pággí* to irrigate a plot.

*Tád*.—An earthen weir, on some canals particular villages claim the right to have the bed for a mile or so left at a higher level when the clearances take place. It gives rise to numerous disputes.

*Sailaba*.—Lands dependant entirely on river or canal inundation.

*Dhund*.—A creek or back water of the river. A favorite place to start a canal from.

*Pand*.—The tail of a canal.

*Chap*.—A dam of brushwood to raise the level of the water.

*Sukh bund*.—An earthen dam that does not allow a drop to get past.

BHAUGULPORE, }  
May 6th, 1874. }

E. A. S.

Bridge

Fig. 1.  
Bridge, 1/2 mile of Shahpore Canal  
Longitudinal Section

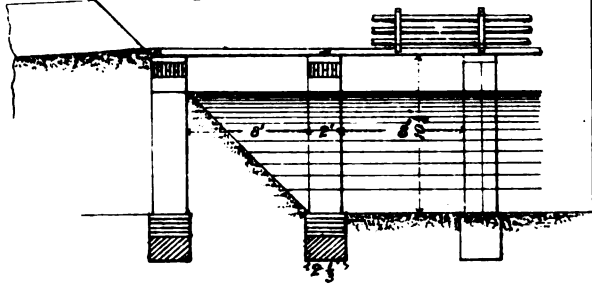


Fig. 4.  
Luftabad Road Bridge  
Half Section

of Fall

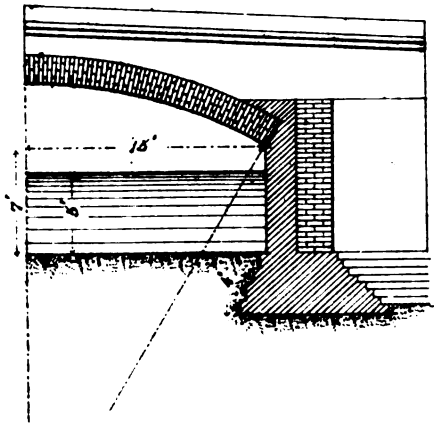
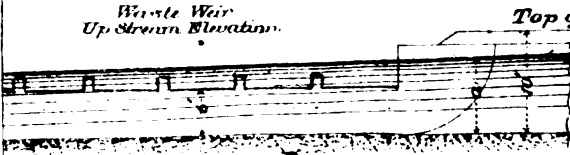


Fig. 8.  
Waste Weir  
Up Stream Elevation

Top of Bank  
Abutment







## No. CXXX.

## MOLESWORTH'S RATCHET DREDGER.

[ *Vide* Plates LXXVIII., LXXIX. and LXXX. ]

By G. L. MOLESWORTH, Esq., *Consulting Engineer to the Government of India for State Railways.*

THE Ratchet Dredger has been designed to remedy a defect which has been found to exist in dredgers of the class, in which the cutting edges or jaws are, after excavation, at the bottom of the machine. In such dredgers (if the complete closing of the jaws is prevented by nodules of kunkur, by grass, by stones, or by any other obstacles) the sand or liquid mud that has been excavated will run out with the water during the operation of hoisting the dredger from the well; and it is a very common occurrence to find the dredger when brought to the surface, either empty or containing a mere handful of material.

In the Ratchet dredger this defect is remedied by causing the jaws to move after excavation to a horizontal position (or nearly so), thus securing all the material that has been excavated. The action of the dredger is simple, it is lowered in the position shown in *Fig. 1, Plate LXXVIII.*, and on reaching the surface to be excavated, motion is given to the jaws by alternately raising and lowering the lifting chain, until the scoops have reached the position shown in *Fig. 2, Plate LXXVIII.* A self-acting detent at this juncture throws out of gear one of the pawls, and the action of the other is continued until the scoops reach the position shown in *Fig. 3, Plate LXXVIII.*, and as there are no more teeth of the ratchet to be taken up by the pawls, the action ceases, and the dredger is hoisted in this position to the surface.

The emptying of the dredger is made self-acting, (as shown in *Fig. 4, Plate LXXVIII.*), by two hooks, which are inserted between the jaws;

the weight of the dredger as it is lowered causing the scoops to be restored to their original position with relation to each other.

Those who use the dredger, should familiarize themselves with its action by a few trials on dry ground, before they use it in deep wells.

A patent has been obtained for the invention, merely with the view of securing its use to the Government of India; and all Government departments, as well as Guaranteed Railway Companies in India may use it free of royalty.

A more detailed description of the dredger, and the mode of using it, is given in the following specification.

*Specification of Molesworth's Patent Ratchet Dredger for dredging or excavating materials from deep wells.*

The details of the Ratchet dredger are shown in *Plates LXXIX. and LXXX.* It consists of two scoops, or buckets of convenient form marked J and K; both scoops revolve on the same centre, but the outer scoop revolves freely on the axle or shaft L, whilst the inner scoop is keyed, or otherwise firmly fixed to the shaft.

On the scoop J is fixed the ratchet M, and on the square portion of the axle L is fitted the ratchet N, so that the scoop J must revolve with the ratchet M; and the scoop K must revolve with the ratchet N.

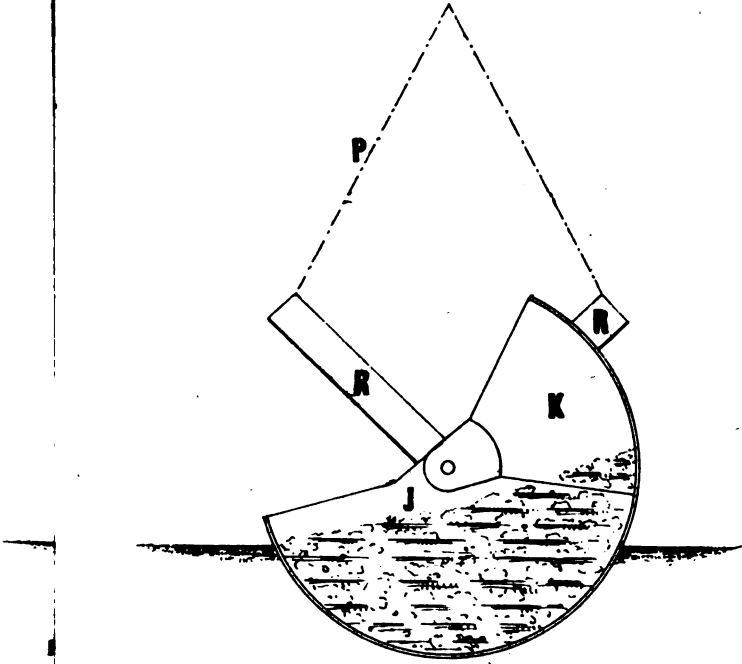
The dredger is lifted by means of chains or ropes PP attached to two pairs of lever-arms RR; each pair of lever-arms being formed of a bent bar. These arms revolve freely on the axle L, and studs on them hold pawls S and T, which gear into the ratchets M and N, respectively; each pawl is formed with a projection marked, *s* and *t*, respectively, for throwing the pawls out of gear.

On the outer scoop is a detent V, so fixed that, when the cutting edges of the scoop approach each other, it comes into contact with the projection *t*, and throws the pawl T out of gear.

The inner scoop is furnished with a catch W, so formed as to prevent any rotation of the scoop when in gear, but when the cutting edges rest on the ground, the catch W falls out, leaving the scoops free to revolve. The arms are furnished with a stop Z, which does not allow them to be raised more than 45° from the horizontal line.

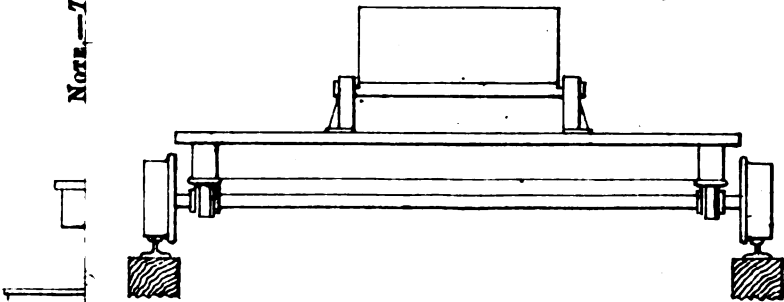
Two hooks A and B are provided for opening and discharging the dredger, the hook A is attached by a rope to the shackle of the lifting chains, whilst the hook B is attached at a convenient height by means

FIG 3. DREDGER AS RAISED.



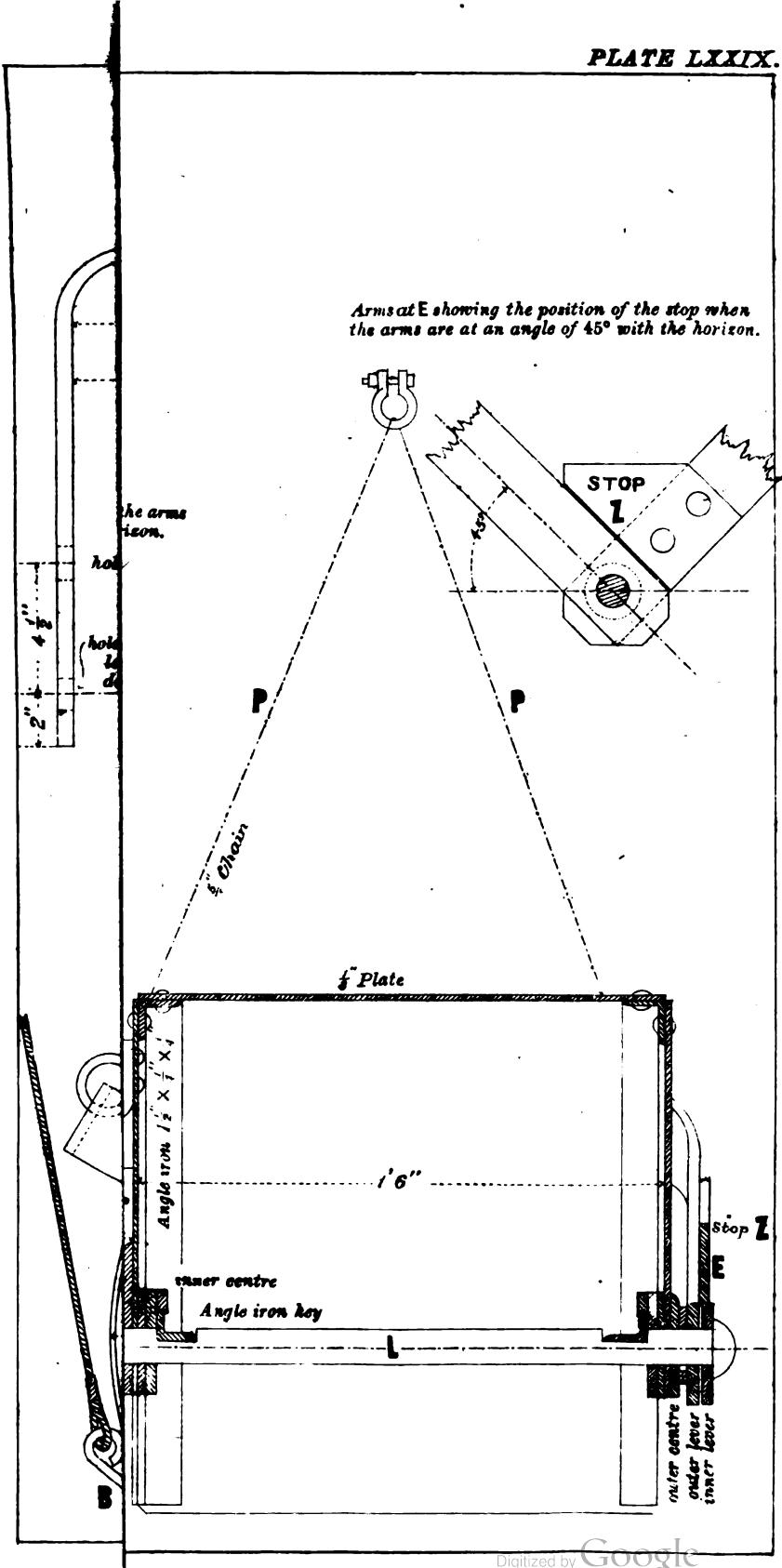
*Note.—This cross should be longer.*

FIG 5. END VIEW OF TIPPING TRUCK.

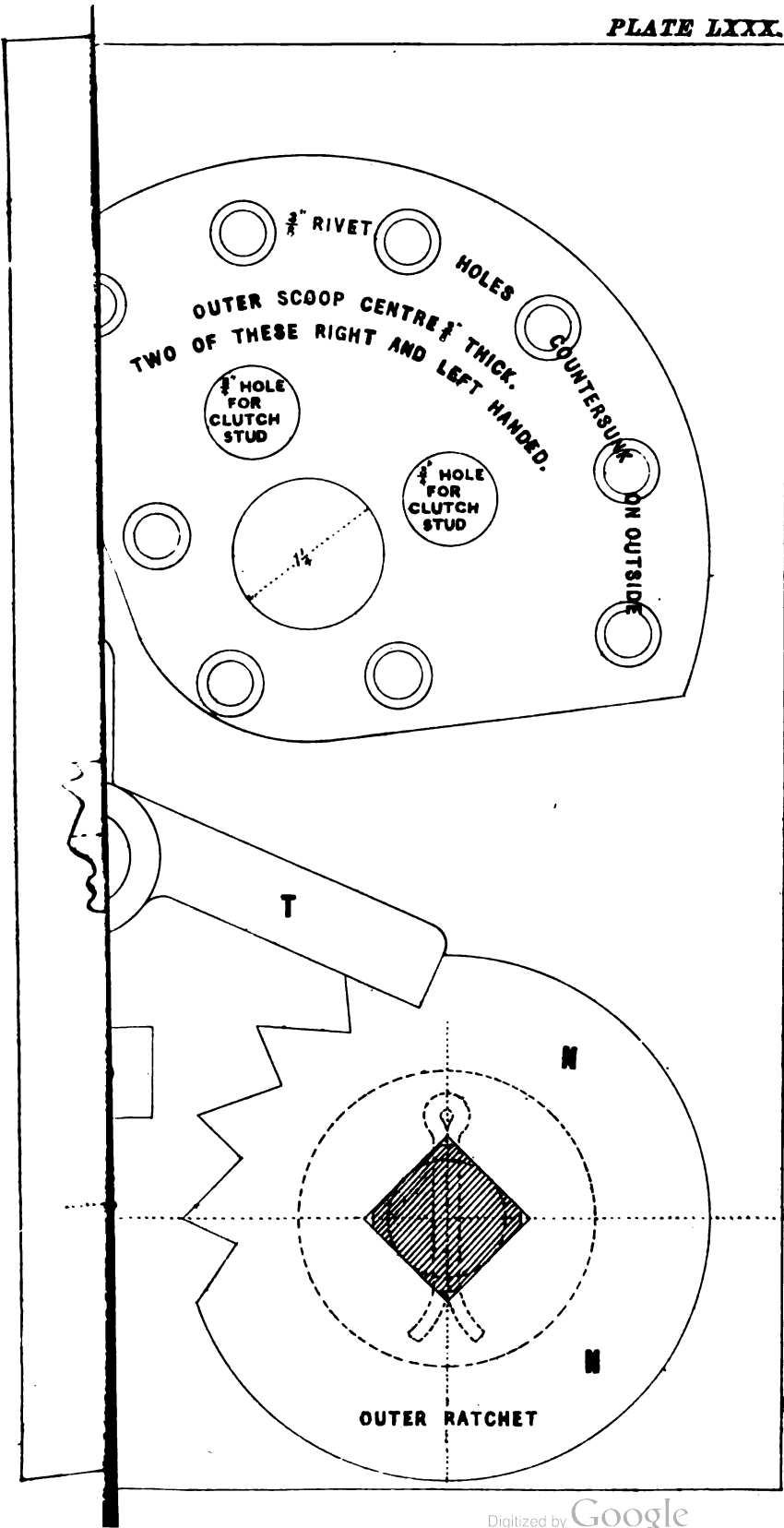




Arms at E showing the position of the stop when the arms are at an angle of 45° with the horizon.











of a rope which passes round, and below the outer scoop, and then up to a fixed point in the hoisting derrick or scaffolding.

The mode of using the dredger is as follows :—the chains PP are raised until the arms are at about an angle of  $45^{\circ}$  from the horizontal line, the catch W is put in position ; then, the outer pawl T, and, afterwards, the inner pawl S are thrown into gear ; the dredger is then ready to be lowered.

When the dredger reaches the bottom of the well, the cutting edges rest on the material to be excavated ; the catch W falls out, leaving the scoops free to revolve, and at the same time the arms fall by their own weight to the horizontal position, taking up a couple of teeth in each ratchet ; the lifting chain should then be raised and gently lowered four or five times in succession, gradually increasing the lift each time, the first lift being about 1 foot, the second  $1\frac{1}{2}$ , the third 2 feet, the fourth 3 feet ; and the cutting edges as they close, excavate the material between them. On the second lift, the outer pawl T will probably be thrown out of gear by the detent V, and the remaining lifts will act only on the inner ratchet S, so that the outer scoop will revolve, pushing back before it the inner scoop, until the pawl S reaches the last tooth of the ratchet. The dredger must then be hoisted up with the materials excavated ; the outer scoop being beneath with its two edges nearly on a level, and the inner scoop nearly in the position it occupied when the catch W was released.

When raised to the surface, the dredger must be hoisted to such a height, that the two hooks A and B may be inserted between the cutting edges ; a small tipping truck may then be run under the dredger, and the pawl S put out of gear by a blow on the projection s, and thrown back. The dredger must then be slowly lowered, and by the act of lowering the hook B will draw back the outer scoop into its original position, thus throwing out the materials into the tipping truck. When the dredger has been lowered, so as to bring the catch W sufficiently near to the outer scoop, it is put into gear, the hook A released, the outer pawl T is then thrown into gear, the hook B released, *then* the inner pawl S is thrown into gear, and the dredger is again ready to be lowered ; the tipping truck having been pushed away to allow it to descend. (If preferred, the tipping truck may be dispensed with, and the dredger hauled out sideways to a platform to be discharged as with ordinary dredgers).

G. L. M.

August 19th, 1874.

---

**No. CXXXI.**

---

**PROPOSED GRATING FOR STOPPING FLOATING  
LOGS NEAR HEAD OF GANGES CANAL.**

[ *Vide* Plates LXXXI. and LXXXII.]

---

By J. S. BERESFORD, Esq., C.E., *Exec. Engineer.*

---

MUCH of the damage sustained by falls on the Ganges Canal is attributed to large logs of wood which sometimes float down, and passing over the falls, remain below, where, owing to the peculiar action of the water, they play against the masonry with most destructive violence; the largest are usually of deodar, weighing when saturated with water about 40 lbs. per cubic foot.

Three or four years ago a boom, formed of logs connected by iron couplings, was placed across the canal above Jawalapore bridge in the 4th mile, but it offered so much obstruction to the current, that it broke in a few days, the couplings having worn thin, owing to the constant working on each other. The boom was put up a second time with no better result: after this the matter was allowed to stand over. About the end of 1872, when in temporary Executive charge of the Northern Division of the canal, I was requested to give the matter consideration, and if possible devise some kind of rigid structure resting on piers, and arranged so as to offer little obstruction to the water, and at the same time to catch all logs that might come. What I then proposed was neither adopted nor rejected, pending, I believe, experiments on some other untried means, but a short description of it may not be without interest.

Above Jawalapore bridge, which is  $3\frac{1}{2}$  miles from the canal head, has hitherto been selected as the most convenient site for such a structure,

but a point 100 feet above Ranipore falls, at the 5th mile, is better suited to my design, because the water surface there fluctuates much less than at the other place, which is important as rendering a lifting apparatus unnecessary; and, another reason is on economical grounds, the men employed on working the lock close by would be available for removing logs, drift, &c., caught by the grating. In designing I was guided by the following considerations:—

The heaviest log that has been known to come down, measured 20 feet long by 4 feet diameter; but, supposing one twice this length to come, its weight would be  $40 \times 4^2 \times .7854 \times 40 = 20,112$  lbs., almost 9 tons. The surface velocity above Ranipore falls, with a high supply in canal, I found to be 4 feet per second, and this is the velocity with which the log would move before striking, or the same it would have after falling vertically through a height of  $\frac{4^2}{64} = .25$  feet = 3 inches, therefore in bringing it to rest, a quantity of accumulated work equal to  $20,112 \times .25 = 5,028$  foot pounds would have to be overcome; or, expressed more scientifically, this is the energy of the shock to be borne. To overcome this by the mere elasticity of a beam rigidly fixed at the ends, would hardly be practicable, requiring one of large dimensions. Thus a reference to Rankine's Engineering, Art. 173, (where the subject is treated fully,) Eq. 4, shows that a square beam 25 feet long would require a thickness of  $16\frac{1}{2}$  inches, and this is supposing it struck in the middle, taking proof modulus of rupture of *säl* at 4,000 lbs. per square inch, and modulus of elasticity at 2,400,000 lbs: the corresponding deflection would be  $1\frac{1}{2}$  inches, and maximum horizontal pressure on each end of beam 40,224 lbs. = 18 tons: but this is the most favorable case. When the log struck close to the end of the beam, the shock, being chiefly concentrated in one place and not having the spring of the entire beam to soften it, would produce an immense pressure on the nearest pier, and the matter of fixing the ends of the beam securely would be a most difficult one.

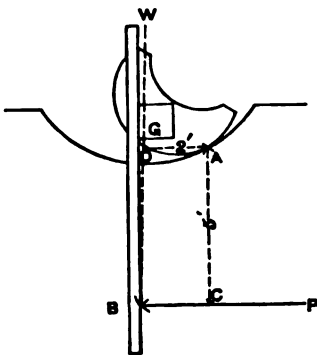
Besides, in the present case, such a beam could not well be placed in a suitable position without obstructing the water. In practice it would have to be placed above water surface, and the log received by smaller bars fixed vertically or sloping, and dipping into the water; but these having to bear most of the shock, would to a certainty succumb: this arrangement would also produce a wrenching strain on the beam, render-

ing it difficult to keep its ends fixed. It is, therefore, pretty evident that some kind of a yielding structure is necessary; but while of this nature, it should also be definite in its movement, at the same time offering little obstruction to the current. My design, which is best explained by the accompanying plates meets all the conditions of the case. Wood or iron may be used for simplicity sake, I have made the chief parts of wood. The grating slopes up-stream at an angle of  $45^\circ$ : the bars are 10 feet long, 6 inches square and placed 2 feet apart, centre to centre, (they can be placed at any distance apart,) they are joined to and supported by a beam 1 foot square, and 25 feet long. This has its ends firmly fixed into toothed rockers of cast-iron, curved to a radius of 2 feet, and these rest and roll on corresponding cast-iron segments, curved to a radius of 4 feet. The grating which dips a foot or two into the water, (depending on supply,) is thus free to rock backwards and forwards, but in doing so, the whole beam, grating &c., is lifted through a certain height. When the grating becomes vertical, the centre of gravity, marked G in *Fig. 3, Plate LXXXII.*, is raised about 1 foot. The weight of this moving part is 6,600 lbs., made up of wood 5,620 lbs.; wrought-iron bolts and straps, 180 lbs.; and cast-iron rockers, 800 lbs. Now let  $x$  equal height to which centre of gravity of grating must be raised before bringing our supposed log to rest, then

$$6,600 x = 5,028$$

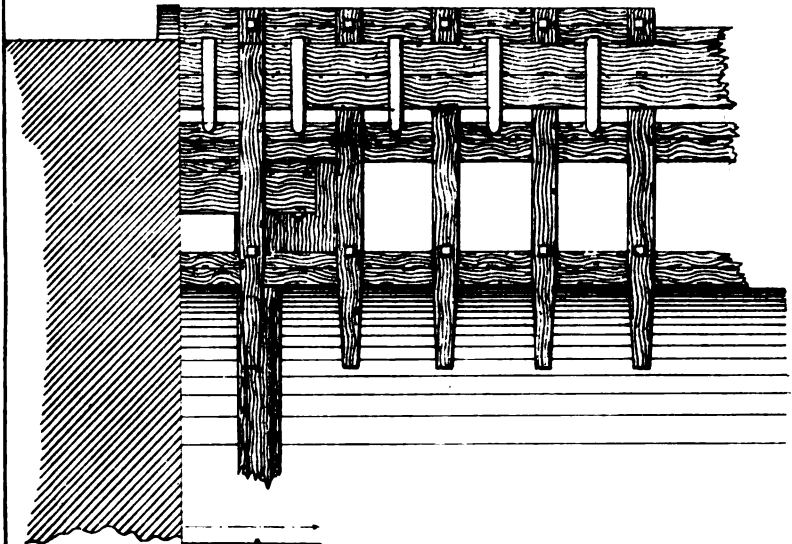
$$x = \frac{5,028}{6,600} = .76 \text{ feet} = 9 \text{ inches.}$$

The position shown in *Fig. 4, Plate LXXXII.*, where centre of gravity

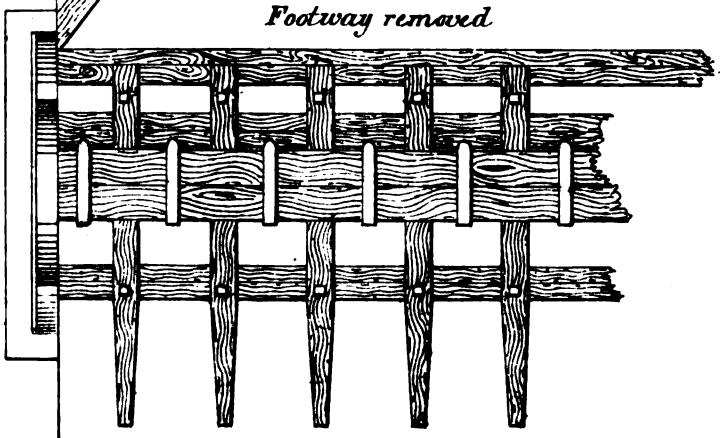


appears raised about 0.9 feet, is somewhat exaggerated. The manner in which the grating acts is thus seen to be simple and effectual. Next as to the strength of the different parts. A reference to accompanying sketch will show how the forces act. Let  $W$  represent the weight of the grating, and  $P$  the horizontal pressure exerted by log when just being brought to rest—it is then a maximum.  $A$  is the point on which the rocker for the moment rests, and is that about which moments are to be

Canal.



*Plan of Grating  
Footway removed*



20 feet





es Canal.

ng position  
log to rest

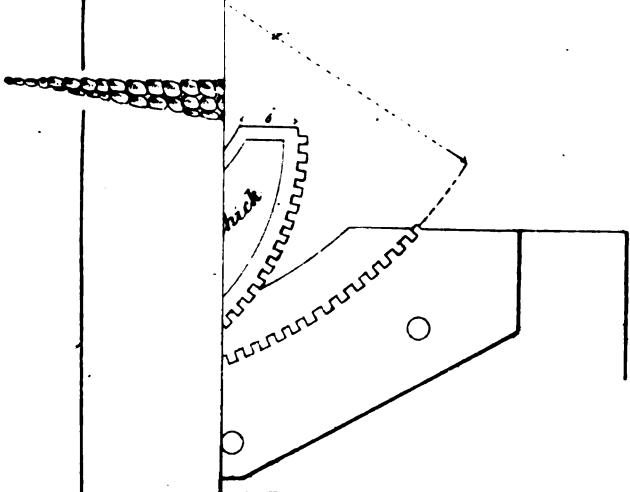
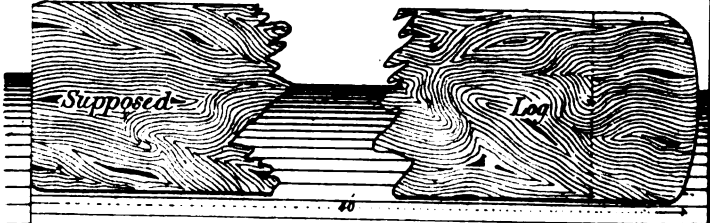
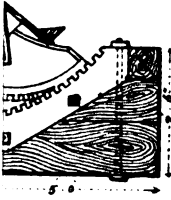
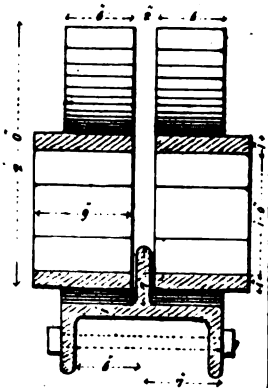


Fig. 6  
Section on C, D



of Figs 5 & 6. 1/4 feet to 1 inch







taken. AC is a perpendicular let fall on the line of action of P, and AD the same on the vertical from G, the centre of gravity of the grating. AC and AD measure, respectively, 5 feet and 2 feet, (found by scaling from a large drawing, and practically correct,) then

$$W \times 2 = P \times 5, \text{ or}$$

$$6,600 \times 2 = P \times 5. \therefore P = 2,640 \text{ lbs.}$$

This if applied at one end of the grating would cause a wrenching moment on the end of the beam =  $2,640 \times 5.5 \times 12 = 174,240$  inch pounds; then assuming the latter when fixed in the rocker to be a circle of one foot in diameter, its moment of resistance to torsion is

$$\text{Moment} = \frac{f h^3}{5.1} = \frac{3,000 \times 12^3}{5.1} = 1,69,410 \text{ inch pounds,}$$

or practically equal to the wrenching moment to be resisted,  $f$  being taken at 3,000 lbs. for  $\text{s\aa}$ l. But in most instances, this wrenching moment would act more or less away from the ends of beam, and thus be resisted by two cross sections, and so cause a much less stress than above. Besides the log has been assumed twice the size of what is ever likely to float down the canal. Next as to the strength of bars—they are 6 inches square, except end ones, which are 8 inches square for reasons given below. The bending moment on these bars caused by pressure  $p$  is

$$2,640 \times 5.5 \times 12 = 1,74,240 \text{ inch pounds.}$$

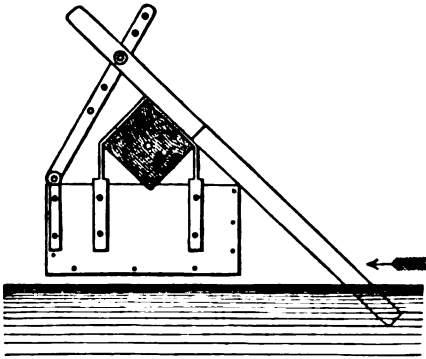
The moment of resistance of one bar, taking working modulus of rupture of  $\text{s\aa}$ l at 2,000 lbs., is  $M = \frac{1}{8} \times 2,000 \times 6^3 = 72,000$  foot pounds. Thus one bar of itself is not sufficient to resist above, but they are so connected to cross bars, that pressure on one is distributed over several—and it appears that less than three bars will be sufficient.

To meet the case of a log striking only on the end bar, the size of the latter in each instance is to be increased to 8 inches square. It will be seen the bars are attached to the beam, in a manner which dispenses with  $\text{solt}$  holes in the former, thus doing away with one source of weakness. The strength of the iron rockers is much in excess of that required, but the sockets have to be large enough to be firmly fixed to the ends of the beam. The strength of suspending straps and bolts is also in excess.

It may be observed that in the foregoing calculations, the entire energy of the shock is assumed to be spent in raising the grating—and practically this is correct, as that lost in friction and molecular changes is very small compared with the whole. The elasticity of the grating and log has also

been neglected, as this would have little or no effect, because when the grating first begins to move, the pressure is very small, and in no case becomes great. The whole distance, as regards the log, through which the energy of shock is overcome, is about 4 feet, and the mean pressure on log and bar therefore only  $\frac{5,028}{4} = 1,257$  lbs., and just about double this at the worst moment.

This, therefore, compares very favourably with the pressure observed in the case of a fixed beam. The grating was to rest on piles, as shown in *Plate LXXXI*.—masonry piers might be used, but the expense of laying their foundation dry, even during a canal closure, would be great, on account of the large quantity of water which leaks through the head. The bed above and below piles would have to be pitched, as shown, to prevent scour. The pathway on top of the beam is to admit of men removing logs, &c., while at the same time it protects the beam from the sun. The cost of such a grating, including piles, pitching, &c., taking sal wood at Rs. 4 per cubic foot; wrought-iron, Rs. 16 per maund; and cast-iron, Rs. 10 per maund, would come to Rs. 1,200 per bay of 25 feet, or Rs. 48 per running foot. I have not calculated what an iron structure of the same nature on screw piles would cost.



The form of grating which first suggested itself is represented in this sketch. The beam was to turn on gudgeons, and have heavy counterpoises suspended as shown.

The shock would be expended in raising the counterpoises. The advantage of the rockers, however, is that they serve to utilize the weight of the beam and grating, the structure itself being the only counterpoise required.

J. S. B.

6th August, 1874.

---

**No. CXXXII.**

---

**ON THE CONSTRUCTION OF OBLIQUE ARCHES.**[ *Vide Plate LXXXIII.* ]

---

BY A. C. LAWFORD, Esq., *Assoc. Inst. C.E., Exec. Engineer, D. P. W., Madras Presidency.*

---

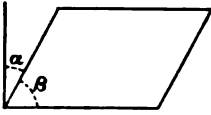
A great impetus has been given to Engineering works of all descriptions in this country, and of these, works relating to means of communication are, as shown by recent events, by no means the least important.

The following detailed description of one mode of constructing oblique arches may therefore be of service.

The method to be described which may be called the equilibrated system differs from those ordinarily employed, all of the latter being based on one or other of two principles, viz., that of considering a skew arch, as the thread of a screw wrapped round a cylinder, or that of a cylinder cut obliquely. Its advantages are—that it is theoretically sounder, the thrust of the arch being at every point at right angles to the face of the abutment; that the elevation being a segment of a circle the construction of the arch is far simpler when the necessary calculations are worked out, and these involve merely a knowledge of elementary Trigonometry and of Logarithms.

The mathematical theory was first investigated by Mr. Sang, C.E., of Edinburgh, and given in detail in the *Civil Engineers' and Architects' Journal*; in an abridged form it forms part of this Article.

It is first necessary to explain that the angle of skew differs from that of the ordinary systems, being the angle between a perpendicular to the face of the abutment, and the face of the arch; thus the angle  $\alpha$  is the "angle of skew."



Having determined the span and rise of the proposed arch with the angle of skew, the next step is to calculate the breadth of the courses of stones on the face of the arch, by the formula

$$\frac{M \sin s}{R} \times v = \log \tan \left( 45^\circ + \frac{i}{2} \right),$$

where  $i$  is the angle subtended by

the breadth of each course as shown in the figure.

$M$ , the Modulus of common Logarithms, '434294481.

$s$ , angle of skew defined above.

$R$ , radius of soffit.

$v$ , half the length of a stone to be fixed as most convenient.

With the values of  $\frac{i}{2}$  and therefore of  $i$  determined by this formula, the lengths of arcs subtending these different values of  $i$  which are the breadths of the courses, can be easily found from a table of lengths of arcs, corresponding to known angles. In the case of a brick bridge, these data are sufficient, and the next step is to mark on a line drawn on crown of soffit of centering, parallel to the abutments, the half lengths of stones decided on. Through these points, draw arcs parallel to the face of the arch, and on each face of the arch set off the breadths of the courses already ascertained, bearing in mind that the breadths are *all* set off from the line drawn on the crown of the soffit as their origin, and that as this line passes through the middle of the centre course on the face, a half breadth will be set off as the first measurement on each side of this line.

Through these points draw lines parallel to the line on crown, intersecting the arcs parallel to the faces, and forming with them parallelograms. Then the diagonals of the parallelograms in each successive course in the direction of the diagonals, give the directions of the courses. The elevation and longitudinal section parallel to face being segmental, (the section on square being an ellipse,) the joints radiate

from the centre like an ordinary arch, and can easily be gauged by an ordinary L gauge.

This fact of the elevation being segmental, greatly simplifies the construction. In a brick bridge, the courses being marked off, the work is quite as easy as in ordinary arch. In a stone bridge too, this system saves great trouble and expense, for the twist on the face of each course being very slight, may be practically disregarded, or if attended to, will entail infinitely less trouble and expense, than is the case with spiral courses. All practical difficulties, as twist on the face, focal eccentricities, are thus avoided.

Toothings are, however, equally necessary as in other methods, but from the fact of the vertical joints radiating to a centre, they are more easily built.

In the case of a stone bridge, the sizes and shapes of the stones will of course differ from springing to crown, but each alternate stone in a horizontal direction parallel to the abutments is of the same size and shape.

To ascertain the sizes and shapes therefore, it is advisable to draw out a plan and elevation of the arch to a large scale, and for this purpose the calculations though equally simple must be extended.

For the necessary data for the plan having  $i$ , we must find  $\sin i$ , or (using logarithms to facilitate the working),  $\log \sin i$ , for its different values; adding to each  $\log$  radius of soffit, and then find the numbers corresponding to the sum of these logarithms.

These numbers give the breadths of the courses as seen in *plan*, and must be laid off from crown towards abutment, always measuring from centre line on crown as the origin, and *commencing* with half the *breadth* of a stone. The lines representing the parallel arcs on plan, drawn through the half *lengths* of the stones, being also laid down with the lines drawn through the respective *breadths*, will form on plan the parallelograms above stated. Lines drawn as diagonals to these parallelograms consecutively, will give the direction of the courses in plan.

The toothings can also be shown by laying off the depth of the springing course, as seen in elevation, diminished by  $\sin i$ , *vide Plate LXXXIII*.

For the elevation we must add together  $\log \cos i$  to  $\log$  radius, and find the numbers corresponding to the sums of these logarithms. These numbers must be laid off from the centre along a radius passing through crown, and through these points lines drawn parallel to springing line.

The intersections of these *aa*, *bb*, *cc*, with the curve of the face, will give the *breadth* of the courses as seen in elevation. Through these intersections draw lines radiating from centre, and on them lay off the depths of the stones calculated as follows:—

Assume depth at crown, and adding log of this depth to log sec *i* for its different values, find the number corresponding to the sums of these logarithms, or the different depths of the stones.

The curve passing through these extremities of these lines, give the extrados.

A plan and elevation of an arch of 30 feet span, rise six feet, angle of skew 30°, with the necessary calculations are appended, in order to render the explanation perfectly clear.

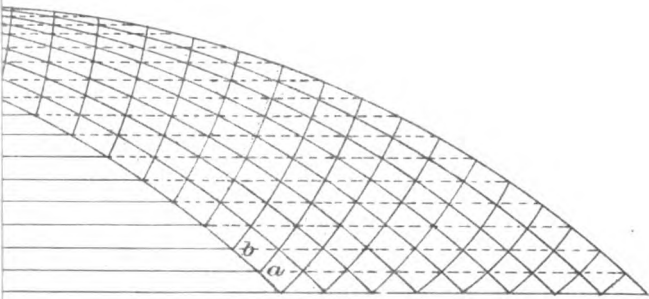
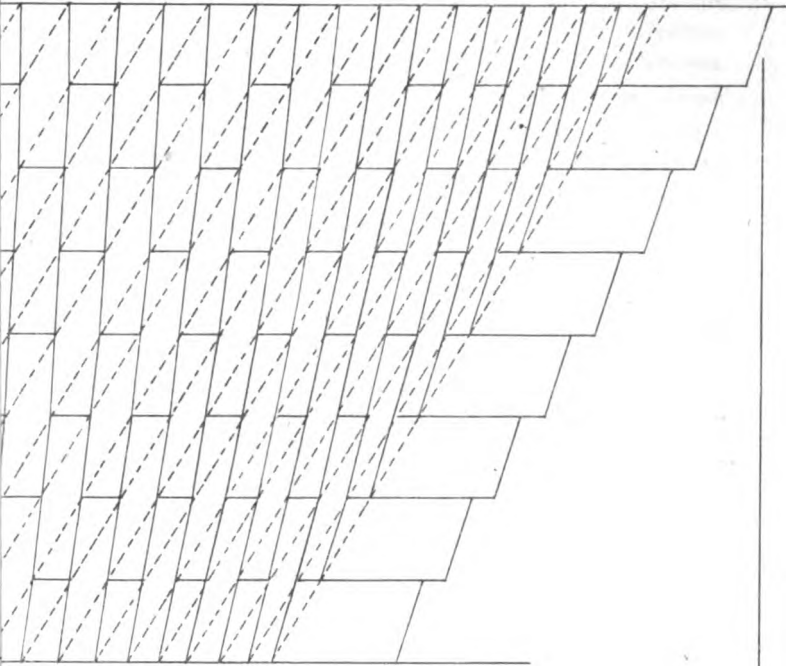
In actual practice, if an earthen mould to full size be built, and the courses laid down according to the above directions, a block of stone can be at once trimmed on its under side to the shape of the soffit, and the general shape of the stone on its vertical faces and sides can be obtained by the L gauge mentioned above.

*Theory of the Equilibrated Arch.*—"It is a common idea that the oblique is weaker than the right arch, and that the twist of the stones causes a great waste of material. The truth is, that if both bridges be skilfully constructed, there is no difference in point of strength between them, while the twist on the arch stone of the oblique bridge causes a most trifling loss of material, and therefore there should be no hesitation to adopt that which agrees best with the rest of the line. There is no limit to the obliquity, nor need even the several abutments run parallel with each other.

The general question of the construction of an arch resolves itself into two parts, the first—relating to the connection which ought to exist between the curvature of the vault, and the weight piled on each portion of it—is absolutely identical in the two cases of right and oblique bridges, and is therefore left out in the present enquiry; the second however,—relating to the forms of the arch stones—bears directly on the oblique arch, and will therefore engross almost our whole attention.

The outline of the bridge, and the form of the vault having been determined on, the problem becomes this:—*To cover the surface of the centering with blocks of such sizes and forms, as may insure the stability of the structure.*

ARCH.







Now if it be premised that the curved surface of the vault must never be vertical, the solution of the problem can always be attained.

It is clear from the general form of a bridge that the lines of pressure ought to run from one abutment to another, and should be contained in vertical planes parallel to the walls of the parapet. Imagine then that the vault is intersected by a multitude of such planes, the lines of intersection will indicate the direction in which the pressures ought to be transmitted from block to block.

Now the stability of a structure is obtained by making the surfaces at which the pressures are communicated perpendicular to the directions of those pressures, and therefore all that is required is to trace on the surface of the centering a line which will cross all the lines of pressure at right angles. In the case of the right arch, that line is parallel to the abutments, but in the oblique arch, it becomes bent in a peculiar manner; at the crown of the cylindrical oblique arch the joint line is perpendicular to the parapet, of course it begins to descend on the surface of the vault, and as it descends it gradually bends away from that direction to become more and more nearly parallel to the abutment.

If the crown line be regarded as the abscissa, and the line of pressure as the corresponding ordinate of the joint, the differential co-efficient of the line of pressure is in all cases proportional to the cosine of the inclination which its extremity has to the horizon. If there be then two closely contiguous joints, the portions of the lines of pressure intercepted between them will be proportional to the cosines of the obliquities, and hence it follows that the breadths (measured on a line of pressure) of the stones in a given course diminish in the ratio just mentioned. It is a well known principle that the strain upon any arch stone is proportional to the secant of the same obliquity, and thus if the depths of the stones be augmented to meet this increased strain, it would follow that each voussoir in any given course ought to exhibit the same extent of section by a plane parallel to the parapet. The arch stones both for convenience of workmanship and for appearance, must be uniformly disposed from side to side, and hence throughout the whole structure they ought to be of uniform volume, with the exception of the half stone left at the end of each alternate course, for the purpose of breaking joint. The deepening of the arch stones towards springing

of the arch is often, though improperly, omitted: in such the above statement does not hold true.

Even although the arch stones were all equally broad upon the centering, those nearer to the abutment would appear narrower on the ground plan. Hence the ground plan of an oblique arch must present a very rapid diminution of breadths towards the springing, the breadths of their projections being proportional to the cosines of their obliquities.

*The side elevation* of a vault with uniform voussoirs, would exhibit narrower intervals towards the crown, the breadth being proportional to the sines of the obliquities, hence the side elevation of a skewed arch must present narrower intervals upon the shoulders.

The breadths are proportional to the product of the sines by the cosines of the obliquities, that is to the sines of twice the obliquities, and thus the side elevation of those arch stones which are inclined at  $45^\circ$  will be the broadest.

The end elevation or the projection of a joint upon the plane of the parapet, possesses the very singular property of being entirely independent of the angle of skew, and of depending solely on the form of the longitudinal section of the vault. This curious fact can be very readily demonstrated. The projection of a right angle upon a plane parallel to one of its sides is always a right angle, and therefore the projection of the joint upon the plane of the parapet must cross the projection of every line of pressure upon the same plane perpendicularly.

But the projections of all the lines of pressure are equal to, and placed side by side with each other, and are so, whatever may be the angle of skew, so that the delineation of the end elevation of a joint which requires only the tracing of a line that may cross all these at right angles, will be performed in exactly the same manner, whether the bridge be more or less oblique. When the angle of obliquity diminishes to zero, that is when the bridge becomes right, the end projections of the joints contract into mere points, which points are the commencements, so to speak of the permanent curves above-mentioned.

The end elevations of the beds of the voussoirs, or rather of the lines formed by the intersections of these beds with the planes containing the lines of pressure, are also normals to the line of pressure, and must therefore be tangents to the end projections of the joints. From this it follows that a short portion of a course or a single arch stone is very

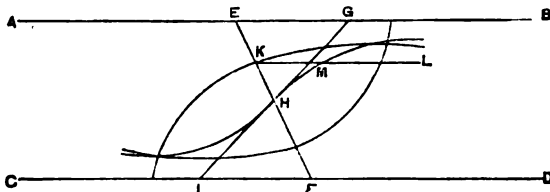
nearly contained between two planes slightly inclined to each other, and that therefore the loss of material arising from the twist of the stone must always be insignificant. If these stones be obtained in squared blocks from the quarry, there will be a loss on the ends of the stones, but this, as every builder knows, can be avoided by proper management in the quarry, and thus on the whole the loss of material for the skew bridge need not exceed to any extent worth naming that for the right one.

The above statements are true of cylindroid oblique arches, whatever may be the forms of their principal sections. They are equivalent to differential equations, and require to be integrated, in order to give practical results; these results vary according to the particular form assumed for the longitudinal section of the vault.

A few of these results are now given, commencing on account of its more frequent occurrence with the circular arch.

On investigating the form of the projection of a joint of a circular oblique arch upon a horizontal plane, a new curve has been arrived at, which is designated the "Double Logarithmic."

Having projected the entire semi-cylinder, of which only a portion can be used with propriety. Let AB, CD be the sides of the projection, and EF parallel to the parapet—the plan



of one of the lines of pressure. Bisect EF at right angles by GHI, and form two logarithmic curves, of which AB, CD, may be the asymptotes EG, the common sub-tangent, their ordinates being parallel to EF. Then draw lines KL parallel to AB, and intercepted between the logarithmics; the middles M of these curves trace out the horizontal projection of one of the joints. The lines AB, CD, are thus asymptotes to the horizontal projection, and this geometrical property illustrates the mechanical impossibility of constructing a semi-cylindric arch without trusting to the cohesion of the mortar.

The introduction of the logarithmic curve into investigations concerning bridges has been of great utility, and the analogy between this curve, and the common catenary is striking.

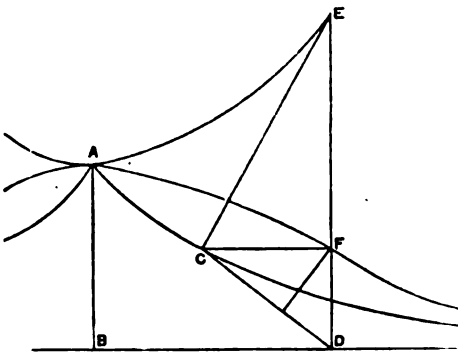
The catenary is also formed by bisecting the interval between two logarithmics, but these have a common asymptote with rectangular coordinates, while the bisected line is parallel to the ordinate. The computations needed for the delineations of such projections are by no means tedious; they may be performed readily by help of Napierian Logarithms, but a better method (capable of giving all the projections will be given shortly.

It may be expected from what has been said of such elevations in general, that the end elevation of a circular oblique arch shall prevent some interesting peculiarities.

The end elevation of a joint ought in fact to cross at right angles, the circumferences of circles described with equal radius from points lying in a straight line, now this is the distinguishing characteristic of the tractory, and that curve must therefore be exhibited on the projections of all circular oblique arches, on examining the projection of one of the joints upon a vertical plane, perpendicular to the parapets, the genesis of a peculiar curve was obtained, still logarithmic in its nature, and somewhat resembling in its form the superior branch of the conchoid. If we conceive the side elevation of a semi-cylinder to be traversed by horizontal lines, the distances intercepted on these lines bear to the corresponding distances intercepted by a certain normal curve, the ratio of co-tangents of obliquity to radius. This normal curve, which belongs to an arch, with its obliquity  $45^\circ$ , has been named the companion to the tractory; it admits of a very neat mechanical delineation.

Let a rod AB equal in length to the radius of the arch be made to rest upon a smooth board only at the point A, while the extremity B is guided along the line BD. A, will, as is well known, describe the equitangential curve or tractory.

Suppose the guide to which the point B (or in an oblique position D) is attached, carries a vertical rule DFE, and that on that rule there slides a right angle DFC,

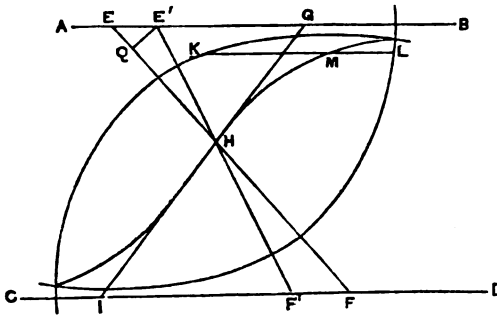


one side of which is constrained to pass through C, (in practice it would be more convenient to lay a jointed rod equal to half AB from the middle of AB to the rule DFE,) then will the point F trace the companion to the tractory. A very simple addition will convert this instrument into that described by Leslie, in his geometry of curved lines for forming the catenary.

A grooved rule has only to be attached, making the right angle DCE, while the groove DF is continued to meet it; E then traces out the catenary.

Since from the nature of the figure  $ED \times DF = AB^2$ , it follows that the companion to the tractory has its ordinates inversely proportional to those of the catenary, and that therefore it might with propriety, be called the inverted catenary. All these projections of the joints, and the forms too of the individual arch stones, can be much more readily obtained from the delineation of the surface of the centering.

Regarding the crown line as the absciss, and the actual lines of pressure as the ordinates, (on the curve surface,) half the ordinate plus  $45^\circ$ , has its logarithmic tangent proportional to the abscissa. Having once obtained the log tangent corresponding to a given distance along the crown line, a simple proportion will give that corresponding to any



other abscissa; the log tangent corresponding to half the length of an arch stone having been found, the repeated addition of that quantity to itself, will lead to a knowledge of the position of the corner of each stone in the whole

structure, the simplest operation of Trigonometry only being needed. Let us now enquire into the faces of an elliptic skew. The horizontal plan of the joint is still a double logarithmic curve, and its delineation, including of course, that for the circular arch is as follows:—

EF being as before the plan of one of the lines of pressure, find HQ a third proportional to the horizontal and vertical semi-axis; through Q draw Q'E', describe the logarithmics having EG' for their common

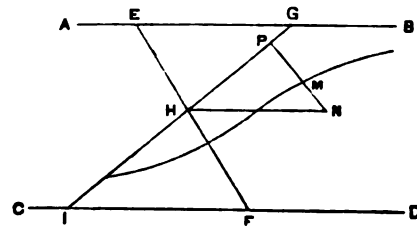
sub-tangent, and having their ordinates parallel to EH, the bisection of the interval between these will give the horizontal projection of the joints. Similarly the side and end projections are modifications of those belonging to the circular arch, they are fully investigated in the Appendix.

The best possible arrangement is to give each square foot of the foundation, its fair share of the whole burden. In order to do this, it becomes necessary to lay a counter arch of a parabolic form (its convexity downwards) upon the pier head, such an abutment course would carry the horizontal thrust to the springing of the next arch precisely as a flat course would, but it would distribute an uniform downward pressure on each horizontal foot, and in this way the foundations would be pressed on exactly, as if the whole weight of masonry work from the crown of the one arch to the crown of the other were piled on it in squared courses. On investigating the forms of the joints of the parabolic skew, I find its plan to be a curve of the third order, the double parabolic, that its end elevation is a semi-cubic parabolic, and that its side elevation is another curve of the same order.

#### APPENDIX.

In the preceding part of the article, the general principles have been stated which ought to regulate the construction of oblique arches; in the second, it is proposed to enter more into detail. The general investigation of the stability of a vault would necessarily be complicated by the peculiarities of the ultimate abutments, and by the assumed directions of the line of pressure, for those directions are within certain limits arbitrary.

For the present purpose it is enough to consider the case of a vault



resting on parallel abutments cylindroid, and having the lines of pressure contained in vertical planes parallel to each other. Let AB, CD, represent the two abutments HN, the crown line EF, PN, the horizontal projection of two of the lines of pressure.

Of rectangular co-ordinates, let the "x" be in the direction HG, the

“*y*” in PM, the “*z*” vertically. For convenience also assume oblique co-ordinates *v* along HN, *u* along NM, and *z* as before, and also the angle GHN = angle of skew = *s*.

The formula of conversion will be

$$\left. \begin{aligned} x &= v \cos s. \\ y &= v \sin s - u. \\ z &= z. \end{aligned} \right\} \left. \begin{aligned} v &= x \sec s. \\ u &= x \tan s - y. \\ z &= z. \end{aligned} \right\} \dots\dots\dots (A).$$

If the equation of the generating curve of the vault of which EF is the projection be taken

$$u - \phi Z = 0 = \dots\dots\dots (B).$$

The same equation will serve as that of the vault itself, or in rectangular co-ordinates

$$x \tan S - y - \phi Z = 0 = B, \text{ whence}$$

$$\frac{dB}{dx} = \tan S \frac{dB}{dy} = -1 \frac{dB}{dz} = \phi Z.$$

The equation of the plane containing one of the lines of pressure is

$$x - X = \dots\dots\dots (C),$$

whence

$$\frac{dc}{dx} = 1, \frac{dc}{dy} = 0, \frac{dc}{dz} = 0.$$

So that the equations of the straight line touching  $B = 0, C = 0$  are—

$$\frac{X - x}{0} = \frac{Y - y}{-\phi Z} = \frac{Z - z}{-1}, \dots\dots\dots (D),$$

where

X, Y, Z, belong to any point in the tangent, *x, y, z*, to the point of contact.

Again, let  $u - \theta v = 0 = E$ , be the equation of a horizontal projection of a joint or in rectangular co-ordinates.

$$x \tan S - y - \theta (x \sec S) = 0 = \dots\dots\dots (E),$$

then

$$\frac{dE}{dx} = \tan S - \sec S \theta v \frac{dE}{dy} = -1 \left( \frac{dE}{dz} \right) = 0.$$

The equations of the joint are,  $B = 0, C = 0$ , therefore those of a line tangent to it are—

$$\frac{X - x}{\phi Z} = \frac{Y - y}{\phi' Z} (\tan S - \sec \theta' v) = \frac{Z - z}{\sec S \theta' v}, \dots\dots\dots (F).$$

The stability of the structure demands that the line whose equations are (F) be perpendicular to that whose equations are (D); therefore the condition of stability is contained in this equation—



$$\begin{aligned}
 &(\phi' Z)^2 (\sin S - \theta' V) = \theta' V \\
 \text{or } \phi' Z &= \sqrt{\frac{\theta' V}{\sin S - \theta' V}} \dots\dots\dots (G), \\
 \text{or } \theta' V &= \frac{\sin S (\phi' Z)^2}{1 + (\phi' Z)^2}
 \end{aligned}$$

The last form may also be put thus—

$$\frac{\delta u}{\delta v} = \sin S \frac{du^2}{du^2 + dv^2},$$

in which the characteristic  $\delta$  refers to the joint,  $d$  to the line of pressure. But  $\frac{du^2}{du^2 + dv^2}$  is the square of the cosine of the inclination of the line of pressure to the horizon, whence if we denote that inclination by  $i$ ,  $\frac{\delta u}{\delta v} = \sin S \cos i^2$ , ..... (H).

When then as is the case at the crown of the arch,  $i$  is zero  $\frac{\delta u}{\delta v} = \sin S$ , but  $\frac{\delta u}{\delta v} = -\frac{\delta y}{\delta v} + \sin S$ , so that at the crown  $\frac{\delta y}{\delta v} = 0$ , that is the horizontal projection of the joint is then perpendicular to the parapet, as might easily have been anticipated, but when  $i$  increases, its cosine decreases, and therefore  $\frac{\delta y}{\delta v} = \sin S, \sin i^2$ ..... (I), must increase, that is the line must bend away from being perpendicular to the parapet, until if  $i$  could reach  $90^\circ$ , it would be parallel to the abutment. Since  $\frac{\delta v}{\delta x} = \sec S$ , the above equation put in rectangular co-ordinate becomes

$$\frac{\delta y}{\delta x} = \tan S \sin i^2, \dots\dots\dots (K).$$

If  $a$  be taken to represent the arc, of which  $u$  is the projection,  $\cos i = \frac{du}{da}$ , and equation (H) becomes  $\frac{\delta a}{\delta v} = \sin S \cos i$ , ..... (L), and thus if we imagine two joints running quite close to each other cutting the crown line at the minute distances  $\delta v$ , the distance  $\delta a$  intercepted between them, on the arc, or the breadth of the course is proportional to  $\cos i$ . The above equation can also be put under the form

$$\frac{\delta a}{\delta x} = \tan S \cos i, \dots\dots\dots (M).$$

Again we have  $\frac{\delta u}{\delta x} = \cot i$ , whence equation (H) becomes  $\frac{\delta x}{\delta v} = \sin S, \sin i, \cos i = \frac{1}{2} \sin S \sin 2 i$ , ..... (N).

$$\frac{\delta x}{\delta z} = \tan S \sin i \cos i = \frac{1}{2} \tan S \sin 2i, \dots\dots\dots (O).$$

From which it will be seen that the general statement made as to the side elevation of the joint is true; lastly, we have—

$$\frac{\delta y}{\delta z} = \sin S \frac{\delta v}{\delta z} - \frac{\delta u}{\delta z} = \tan i = \frac{\delta x}{\delta u}, \dots\dots\dots (P),$$

whence it is that the end elevation of the joint crosses that of the line of pressure at right angles. Before proceeding to apply the above differential equations to particular cases, the following recapitulation may be made—

- Equation (H) gives the horizontal projection.
- „ (L) development.
- „ (O) side elevation.
- „ (P) end elevation of the joint.

And, it is to be remarked, that these equations are absolutely general applying to every skewed cylindroid arch.

The general investigation being now completed, the principles will be applied to specific cases.

In the first case to the circular arch, denoting by  $r$  the radius of the circle,  $i = \frac{a}{r}$ ,  $z = r \cos \frac{a}{r}$ ,  $u = r \sin \frac{a}{r}$   $z^2 + u^2 = r^2$  equations which take the place of (B) in the general analysis. For the horizontal projection of a joint, we have—

$$\frac{\delta u}{\delta v} = \sin S \left(\cos \frac{a}{r}\right)^2 = \sin S \frac{r^2 - u^2}{r^2}, \text{ and thus } \frac{\delta v}{\delta u} = \text{Csc } S \frac{r^2}{r^2 - u^2},$$

whence integrating  $V = r \text{Csc } S \text{ Nep. log } \sqrt{\frac{r+u}{r-u}}$

Now  $v' = r \text{Csc } S \text{ Nep. log } (r + u)$  is the equation of a logarithmic curve to oblique co-ordinates having one side of the semi-cylinder for its axis, and  $r \text{Csc } S$  for its sub-tangent, while  $-v'' = r \text{Csc } S \text{ Nep. log } (r - u)$  is that of a similar curve, having the other side of the semi-cylinder for its asymptote, and thus the  $V$  of the joint which is the arithmetical mean of these is obtained by bisecting the interval between the two logarithmics.

Passing to common logarithms, and putting  $M$  for the modulus 434294481, we have—

$$V = \frac{r \text{Csc } S}{2M} \log \frac{r+u}{r-u}$$

$$U = r \frac{10 \frac{2 M v}{r C s e} s - 1}{10 \frac{2 M v}{r C s e} + 1}$$

The horizontal projection of the joint of a circular skewed arch is thus a new curve, designated the Double Logarithmic, the analogy between this curve, and the common catenary has already been pointed out.

In order to trace the side elevation, we must resume the equation (O), which when adopted to the circular arch is

$$\frac{\delta z}{\delta x} = \tan S \frac{z}{r} \sqrt{\frac{r^2 - z^2}{r^2}}, \text{ whence}$$

$$\begin{aligned} x &= \frac{v \cot s}{Z} \text{Nep. log} \frac{r + \sqrt{r^2 - z^2}}{r - \sqrt{r^2 - z^2}} \\ &= \text{Nep. log} 10 r \cot s \log \tan \left( 45 + \frac{s}{2r} \right). \end{aligned}$$

But the equation

$$x' = \frac{r}{z} \text{Nep. log} \frac{r + \sqrt{r^2 - z^2}}{r - \sqrt{r^2 - z^2}} - \sqrt{r^2 - z^2}$$

is just the equation of the tractory, whence

$$x'' = \frac{r}{2} \text{Nep. log} \frac{r + \sqrt{r^2 - z^2}}{r - \sqrt{r^2 - z^2}} \text{ is the equation of a curve having its}$$

ordinates greater than those of the tractory, by the quantity  $\sqrt{r^2 - z^2}$ .

This curve has been designated the companion to the tractory, on account of the connection which is explained in the article.

The equation for the end elevation of a joint adopted to the circular arch is  $\frac{\delta y}{\delta z} = \sqrt{\frac{r^2 - z^2}{r^2}}$ , whence

$$-y = \text{Nep. log} \sqrt{\frac{r + \sqrt{r^2 - z^2}}{r - \sqrt{r^2 - z^2}}} - \sqrt{r^2 - z^2}$$

which is the well known equation of the tractory. This is the characteristic curve of the circular oblique arch, as all tractories are similar to each other, it is easy to make a table of co-ordinates. The preceding equations enable us to obtain any one of the projections of the joint, and are essential to a knowledge of the nature of the different curves. They are, however, inconvenient when we wish to ascertain the dimensions of the individual arch stones, and need for that purpose to know the intersection of the joint with any one of the lines of pressure.

The equation of the development furnishes us with the means of obtaining these points, as well as all the projections by processes remarkable for their simplicity.

To find this equation (L) is resumed which adapted to the circular arch becomes

$$\frac{\delta v}{\delta a} = Cse S \sec \frac{a}{r}, \text{ whence}$$

$V = r Cse \text{ Nep. log tan } \left( \frac{\pi}{4} + \frac{a}{2r} \right)$ , or observing that  $\frac{a}{r} = i$ , and passing to common logarithms—

$V = \text{Nep. log } 10 r Cse S \log \tan \left( 45^\circ + \frac{i}{2} \right)$  whence by inversion  $\log \tan \left( 45^\circ + \frac{i}{2} \right) = \frac{M \sin s}{r} \times v$ , from which the values of  $i$  can very easily be found, especially when they correspond to equi-different values of  $v$ ; all the operations needed to determine the co-ordinates of various points may now be arranged in a single tabular form *vide* accompanying Table, for an arch of 30 feet span, 6 feet rise; angle of skew  $30^\circ$ .

Proceeding to the elliptic arch, put  $r$  for the horizontal, and  $c$  for the vertical radius, the equation of the curve becomes—

$$\frac{u^2}{r^2} + \frac{z^2}{c^2} = 1, \text{ which takes the place of (B).}$$

This equation may also be put under the form  $V = r \sin \alpha z = c \cos \alpha$ , where  $\alpha$  is the inclination of the trammel bar that would trace out the ellipse; from this we find

$$\frac{\delta v}{\delta \alpha} = \frac{Cse S}{r} \left\{ (r^2 - c^2) \cos \alpha + c^2 \sec \alpha \right\}$$

whence  $V = Cse S \left\{ (r^2 - c^2) \sin \alpha + c^2 \text{ Nep. log tan } \left( 45^\circ + \frac{\alpha}{2} \right) \right\}$

otherwise we obtain

$$\frac{\delta v}{\delta r} = \frac{Cse S}{r} \left\{ (r^2 - c^2) + c^2 \frac{r}{r^2 - u^2} \right\}$$

$$V = Cse S \left\{ \frac{r^2 - c^2}{r^2} U + \frac{c^2}{r} \text{ Nep. log } \sqrt{\frac{r+u}{r-u}} \right\}$$

At first glance it might be thought that this equation gives a new curve; it is however still a double logarithmic, having its part determined as already described.

To find the side elevation we have

$$\frac{\partial s}{\partial r} = \tan S - \frac{rcs \sqrt{c^2 - s^2}}{c^4 + (r^2 - c^2)s^2}$$

whence

$$X = \cot S \left\{ \frac{r^2 - c^2}{rc} \sqrt{c^2 - s^2} + \frac{c^2}{r} \log \sqrt{\frac{c + \sqrt{c^2 - s^2}}{-\sqrt{c^2 - s^2}}} \right\}$$

It is however more easily determined thus—

$$\frac{\partial x}{\partial s} = \cot S \frac{r^2 + c^2 \tan a}{rc \tan a}$$

$$= \cot S \left\{ \frac{r}{c} \cot a + \frac{c}{r} \tan a \right\}$$

But  $\partial z = -c \sin a \cdot \partial a$ , whence

$$X = -\cot S \left\{ \frac{r^2 - c^2}{r} \sin a + \frac{c^2}{r} \text{Nep. log tan} \left\{ 45^\circ + \frac{a}{2} \right\} \right\}.$$

For the end elevation we have recourse to equation (P), which gives

$$\frac{\partial y}{\partial a} = \frac{c^2}{r} \left\{ \sec a - \cos a \right\}, \text{ and thus}$$

$$Y = \frac{c^2}{r} \left\{ \text{Nep. log tan} \left( 45^\circ + \frac{a}{2} \right) - \sin a \right\},$$

which is the equation of the tractory modified by the existence of the factor  $\frac{c}{r}$ . From this equation the determination of the individual points is easily obtained.

For the parabolic arch,  $f$  being the focal distance the equation of the parabola is

$$U^2 = 4fx \text{ whence } Udu = 2fdx,$$

whence again the equation.

$$V = Csc S \left\{ U + \frac{u^2}{12f^2} \right\} \text{ which belongs to the horizontal projection.}$$

$$\text{Also, } x = \cot S \left\{ 2u + \frac{u^2}{6f^2} \right\}$$

$$\text{Or } x = \cot S \frac{2}{3} \sqrt{fx} \left\{ 3 + \frac{x}{f} \right\}; \text{ and also}$$

$$y^2 = \frac{4x^2}{9f}$$

which are the equations of the three projections."

Calculations for an arch of 30 feet span, 6 feet rise, 80° angle of skew.

V	M. $\frac{\sin. S}{R}$	$45 + \frac{i}{2}$	i	Log sin i.	Log cos i.	Log sec i.	Log sin i + log R.	Log cos i + log R.	Log sec i + log d.	or No. corresponding to log sin i + log R. if +	or No. corresponding to log cos i + log R. if +	or depths of arch stones.
1	·00988781	48	39	1 18 36	8 859101	·000112	9 696560	1 337347	·301142	·4972	21 745	2 0005
3	·023951343	46	58	3 56 32	8 837274	·001024	·174733	1 336431	·302054	1 498	21 698	2 0045
5	·043913905	48	17	5 6 34	10 9 058453	·002859	·395912	1 334598	·303889	2 488	21 605	2 013
7	·063886467	49	35	15 9 10 30	9 202625	·005582	·540084	1 331868	·306612	3 468	21 471	2 046
9	·083854029	50	58	4 11 46	8 9 309559	·009223	·647013	1 329233	·310280	4 437	21 295	2 043
11	·103821591	52	10	3 4 14 20	7 9 393742	·013734	·731201	1 323722	·314764	5 386	21 075	2 064
13	·123789153	53	26	7 4 16 32	15 9 462720	·019096	·800179	1 318372	·320126	6 312	20 815	2 09
15	·143756715	54	41	11 19 22	22 9 520762	·025297	·858921	1 312146	·326327	7 218	20 513	2 12
17	·163724277	55	55	15 21 50	19 9 570534	·032326	·907993	1 305118	·333356	8 090	20 191	2 154
19	·183691839	57	8	0 24 16	.. 9 613825	·040175	·951284	1 297289	·341205	8 939	19 828	2 194
21	·203659401	58	19	12 26 38	24 9 650649	·048714	·989108	1 288720	·349744	9 763	19 448	2 137
23	·223626963	59	29	8 28 58	16 9 685175	·058041	1 022534	1 279407	·359071	10 595	19 031	2 286
25	·243594525	60	37	21 31 14	42 9 714914	·068002	1 152373	1 269404	·369032	11 28	18 595	2 339
27	·263562087	61	44	11 33 28	22 9 741577	·078726	1 079036	1 258703	·379756	12 00	18 145	2 397
29	·283529649	62	49	14 35 38	28 9 765449	·090037	1 102908	1 247380	·391067	12 675	17 675	2 461
31	·303407211	63	52	27 37 44	54 9 786888	·101896	1 124347	1 235475	·402926	13 325	17 198	2 529
33	·3232946773	64	54	12 39 48	24 9 806314	·114478	1 143773	1 222939	·415508	13 925	16 709	2 603
35	·3431943235	65	54	5 41 48	1 9 823846	·117566	1 161305	1 209873	·428596	14 50	16 215	2 682
37	·363099897	66	52	6 43 44	12 9 839694	·141128	1 177153	1 196312	·442153	15 045	15 715	2 768
39	·383067459	67	51	4	Not required.							

A. C. L.

## No. CXXXIII.

## MASONRY DAMS FOR RESERVOIRS.

[ *Vide* Plate LXXXIV.]

BY G. L. MOLESWORTH, Esq., *Consulting Engineer to the Government of India for State Railways.*

THE want of some concise approximate formulæ for determining the dimensions of masonry dams for reservoirs having been felt, and expressed to me by several Engineers, I have endeavoured to prepare some simple formula which will fulfil the general conditions required in such structures, with accuracy sufficient for practical purposes, and which will be at the same time capable of ready application, when rapid reference is required, without the necessity for toiling through the numerous and complicated formulæ given by most writers on this subject.

It is not intended, however, that this formula should supersede the more elaborate and perfect treatises on this question.

The valuable Mémoire translated by Colonel Fife, R.E., from the French of M. Delocre, is well worth the study of Engineers, but the formulæ are very numerous, and of so abstruse a character, as to be beyond the reach of many.

Major Tulloch's admirable paper (No. LXVIII., "Professional Papers on Indian Engineering,") containing Professor Rankine's analysis, also forms an important supplement to the Mémoire of M. Delocre.

It will be seen, however, that Professor Rankine's analysis contains thirteen formulæ of a character not suited for ready reference, and after all only an approximation is obtained. Professor Rankine in his

RESEI

lated by Molem

h.

worth's sections.

THE

AM  
SSURE  
ware foot.  
ik feet.

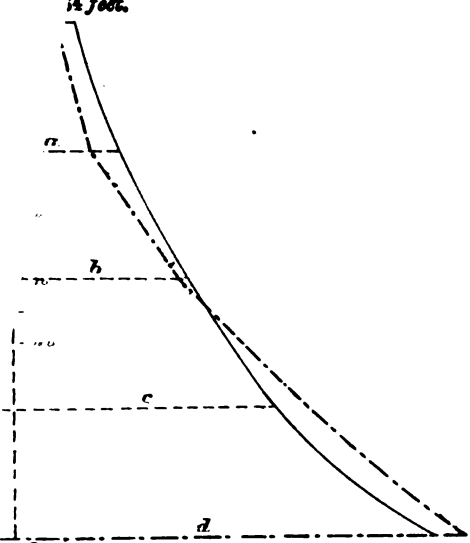
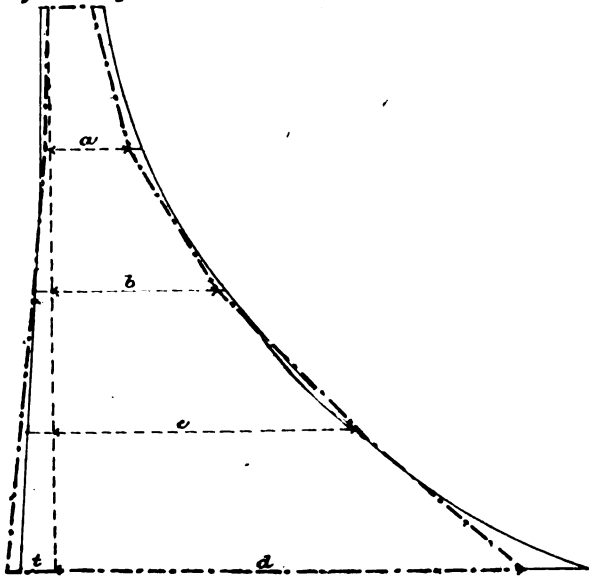


Fig. 8

INE'S TYPE  
OF PRESSURE  
is. per square foot.  
ghat = 180 feet.







analysis says: "In choosing limits for the intensity of the vertical pressure at the inner and outer faces of the wall represented by the accompanying profile, (*vide Plate LXXXIV.*,) I have not attempted to deduce the ratio which those quantities ought to bear to each other from theory of the distribution of stress in a solid body; for the data on which any such theoretical determination would have to be based are too uncertain."

The principle adopted by Professor Rankine of reducing the limits of pressure in the outer face is sound, but his plan of adopting an *uniform* limit of pressure *throughout* the outer surface, appears to me to be erroneous, because the deviation from the vertical line increases in proportion to the depth, and consequently the ratio of the outer to the inner pressure should decrease with the depth, and should *not be uniform*. In Rankine's type, the vertical pressure at the outer surface at a depth of 120 feet, actually *exceeds* the vertical pressure on the outer surface at a depth of 90 feet.

Practically Rankine's plan results in the adoption of a lower limit of pressure *throughout the structure*. The proper course to pursue is, to calculate the off-sets  $y$ , with gradually diminishing values for  $P$ , corresponding with the depth  $x$ ; the result will give additional strength where it is required, without overburdening the upper portion of the dam with unnecessary and consequently injurious weight. In *Fig. 7*, I have done this, commencing with the limit of  $P = 20,000$  at the top, decreasing to 16,000 at  $c$ , and 15,400 at  $d$ .

In high dams, such as those shown in *Figs. 3 to 8*, inclusive, the formula may be altered so as to provide a gradual decrement in the limits of pressure.

In the Mathematical investigations of MM. Graeff and Delocre, no reduction has been made in the limits of pressure at the outer surface. The use of the section suggested by Professor Rankine for depths of fifty feet and less, involves the use of more materials than the old empirical formula, which made the breadth of the dam at the top = height  $\times 0.3$ ; and the width at the bottom =  $H \times 0.7$ .

The formula I propose is given on page 397, it has no pretensions to *Mathematical accuracy*, but it allows a margin of safety with a given limit of pressure, and by increasing the quantity of ordinates, any number of points can be fixed, which will give a regular curve instead of a series of surfaces at different angles of inclination.

In the Furens dam, it appears to me that the divergence from the theoretical type in order to secure a regular curve, has been larger than is necessary or desirable.

Appended to my formula,\* I have given the method I should adopt in practice for applying the formula in determining the general dimensions of any dam.

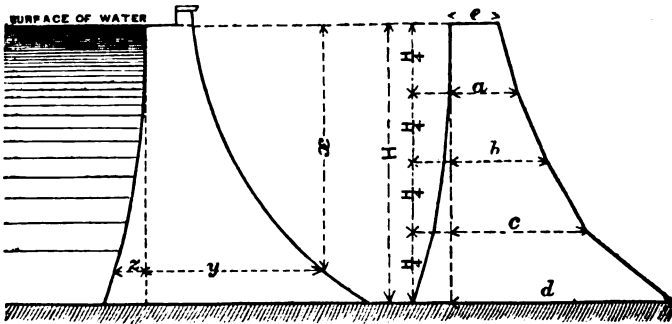
I have adopted this method in the calculation of the comparative profiles (*Figs. 3 to 8, inclusive*). The calculated profiles are shown by the thick dotted lines. I have not in these profiles made any reduction in the limit of pressure on the outer edge, as my aim has been to compare the results of my formula with dams calculated under similar conditions. I have calculated the profile for Rankine's type under two different conditions—first with the limit of pressure nominally adopted; but as this limit has nowhere been reached, I have calculated a second profile with a lower limit of pressure. The profiles calculated by my formulae agree very closely with the forms adopted.

\* The formula is given in the next page.

*Molesworth's approximate formula.*

Fig. 1.

Fig. 2.



$P$  = Limit of pressure allowed on the masonry in lbs. per square foot.

$\alpha$  = Depth in feet of any plane below the surface of the water in reservoir, see Fig. 1.

$y$  = Off-set in feet from vertical line, to outer edge of dam at any depth  $x$ .

$e$  = Off-set in feet from vertical line to inner edge.

$$y = 7.5 \sqrt{\frac{x^3}{P}}$$

$$= 0.6 x \text{ as a minimum, } z = \frac{y}{10}.$$

*Practical Method of Applying the Formula.*

- 1st. Divide the height  $H$  into four parts, see Fig. 2.
- 2nd. Lay off  $a, b, c, d = y$  in the formula\*.
- 3rd. Make  $e = a - \frac{d}{40}$ .
- 4th. Lay off opposite  $a, b, c$  and  $d$  the distances  $x$ .
- 5th. Increase to  $0.6 x$  any of the ordinates  $a, b, c$ , or  $d$ , that may be less than that minimum.

CALCUTTA, }  
 July 25th, 1874. }

G. L. M.

\* In very high dams, the gradual decrement in the limits of pressure may be given by using the

$$\text{formula } y = 7.5 \sqrt{\frac{x^3}{P - (.0013 P x)}}.$$

## No. CXXXIV.

## CONCRETE BLOCKS FOR MANORA BREAKWATER.

[ *Vide* Plates LXXXV., LXXXVI. and LXXXVII.]

By W. H. PRICE, Esq., *M. Inst. C.E.*, Superintendent, *Kurrachee Harbor Works.*

*Introductory.*—In view to the estimate for the Manora Breakwater, attention was directed early in 1866, to the collection of information as to the probability of obtaining, in the neighbourhood, or within convenient reach of Kurrachee, hard stone of sufficient size, for building the more exposed portions of the work.

Accordingly Lieutenant (now Major) Merewether, R.E., Executive Engineer, was deputed to examine and report on the different localities whence such stone might be looked for. Major Merewether's special search extended from Kurrachee, along the coast to Bombay, and afterwards when on other duty, he examined the most likely localities west of Kurrachee as far as Bushire in the Persian Gulf.\*

The result of the search was, that though suitable stone was procurable at some of the places visited, the difficulties and expense of quarrying and conveyance to the coast for shipment to Kurrachee, would have been so great, as to preclude the idea of so procuring, the comparatively limited quantity of stone required for the Manora Breakwater.

The details of the construction of the Breakwater having undergone further discussion, the plan of partially using natural stone in the superstructure was abandoned, and it was decided to use concrete blocks

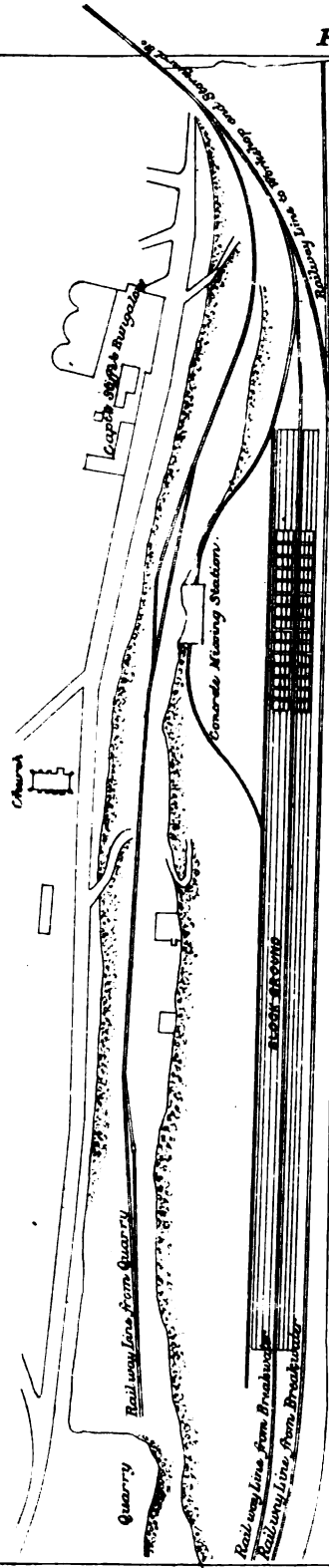
\* See Article No. CCXXVII. of the "Professional Papers on Indian Engineering," First Series.

# KURRACHEE HARBOR WORKS.

MANORA BREAKWATER.

Concrete Mixing Station and Block Ground.

Scale, 250 feet = 1 inch.



GENERAL PLAN





instead. It still however remained to be settled, whether artificial hydraulic lime made on the spot, or Portland cement imported from England, would be the best for such blocks.

After a series of Experiments\* ably conducted by Major Merewether, this question was settled in favor of Portland cement, after duly balancing strength and cost, though at a distance from the seaboard, the latter consideration would have turned the scale in favour of the lime.

The necessary plant and Portland cement having been received from England, and the station for mixing the concrete, and the ground for moulding and stacking the blocks having been prepared, the making of blocks was begun in August, 1870.

The following describes the process by which the 27-ton blocks, nearly two thousand in number, were made for the breakwater. The regular size of the blocks was  $12 \times 8 \times 4\frac{1}{2}$  feet, though some of smaller size were made to suit the irregularities of the bottom near the shore.

*Method of Manufacture.*—At first the proportions of materials used were as follows :—

	By measure.
Portland cement, .. .. .	.. 1 part.
† Sand from the Layarie river, .. .. .	.. 3 „
‡ Shingle from the Manora conglomerate, .. .. .	.. 3 „
Quarry lumps from ditto, .. .. .	.. 2 „

The above proportion of cement was calculated for cement weighing 118 to 120 lbs. to the bushel, or about the weight of Knight, Bevan, and Sturge's cement. But as the Wouldham Company's cement weighs less, (108 to 115 lbs. per bushel,) and White Brother's less still, (104 to 108 lbs.,) when these last were used, the proportions of cement were increased respectively, by  $\frac{1}{20}$  and  $\frac{1}{10}$ .

But after about one-fourth of the number of blocks was made, the proportion of cement was reduced by one-third, and the relative proportions of sand and shingle were also somewhat modified, so that the materials for one block  $12 \times 8 \times 4\frac{1}{2}$  feet = 16 cubic yards, or 27 tons weight, were as follows :—

\* Published in the Extra Number of the "Professional Papers on Indian Engineering," First Series.

† This sand varies in size from very fine to gravel or small shingle.

‡ The shingle is coarse, but the sand, as just noted, supplied the requisite admixture of small shingle.



	Cubic feet.
Portland cement, (Knight, Bevan and Sturge), 9½ casks of which the bulk* here is (the weight being 3,729 lbs.), .. .. .	44
Sand from the bed of the Laxarie river, .. .. .	180
Shingle from Mahora conglomerate, .. .. .	252
Quarry lumps ditto, .. .. .	144

being one part of cement to thirteen of other materials exclusive of water, of which 432 gallons were used in each 27 ton block.

Comparing the English bulk† of cement with that of the finished block, the ratio is  $\frac{1}{10.92}$  or about  $\frac{1}{11}$ .

Comparing the Indian bulk,‡ the ratio is  $\frac{1}{9.82}$  or about  $\frac{1}{10}$ .

When lighter cements were used, the allowance of cement was increased in proportion.

This change, together with some economy effected in the labor, &c., reduced the cost of the blocks by one-fourth, or from eight annas to six annas per cubic foot, including allowance for use of plant.

The changes in question were made, in consequence of suggestions from Mr. Parkes, based in great measure, on information as to proportions adopted with success in the heavy concrete blocks used on the Tyne Pier works.

The proportions used in the beginning were based on the Alderney practice.

The alteration while effecting an important saving in cost, did not injuriously affect the quality of the blocks. This of course depends chiefly on the strength of the mortar, in which but slight reduction was made.

The greater proportion of shingle and quarry lumps left less margin for imperfections in mixing and packing, but this, as well as the slightly reduced strength of the mortar, was compensated for by the blocks being allowed a longer time to set. One month was found ample for setting, and blocks of that age were used frequently in the breakwater with perfect safety.

The accompanying plates illustrate the concrete mixing and block making arrangements, which were found to answer their purpose excellently.

\* See No. LXXXVIII., "Professional Papers on Indian Engineering," of the Second Series.

† See Note above.

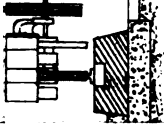
‡ See Note above.

WEE HARBOR WORK

MANORA BREAKWATER.

*Block Ground.*

*Scale, 8 feet = 1 inch.*





The shingle, sand, and concrete were brought to the concrete mixing station, along the upper railway line in wagons, and having been measured out in their proper proportions, (cement by weight on a balance scale, its quantity having been once regulated in relation to bulk,) on the platform, were shovelled into the hoppers of the mixers. The mixers, four in number, worked by a steam engine of 8 H.-P., are Messent's patent, made of cast-iron, of such a shape that when half filled with material, and turned round on the axle, the contents are turned over, (sideways as well as endways,) four times by each revolution.

The charge was half a cubic yard, and to this was added 12 gallons of water from a tank at one end. This quantity is liable to a slight variation, according to the state of the weather, being more in dry and less in moist weather. Nine revolutions were required to make the mixture in the most effectual manner, after which, the trap door of the mixers was opened, and the contents discharged into skips carried on wagons on the railway line below the mixers. The wagons were then shunted along the railway to the block ground, where the skips were lifted by travelling cranes, and their contents discharged into the block moulds. The quarry lumps were added when the concrete was being placed in the moulds.

To each mould was told off, an intelligent mason, to see to the proper packing of the concrete, the placing of the regular measured quantity of lumps, (*i. e.*, four cubic feet measured dry, to one charge of the mixed concrete, in level courses, and with space round each lump, to ensure its being well surrounded with concrete,) and to generally look after the solid moulding of the block.

The concrete should be stiff, though not too dry, a portion of the water being added during the packing, but care should be taken that the liquid cement does not escape from the bottom of the mould, or from crevices in the sides.

To ensure a good "skin" for the block, the lumps should be placed a little inside of the faces, and shovels well worked against the insides of the moulds, so as to force the grout in the concrete against the timber.

The moulding of the block was kept constantly going until finished, as a stoppage, even with resumption after an interval of an hour, tended to cause a separation in the body of the block.

Watering the block for a week after making, was employed to ensure

proper setting, but if continued for a longer period at no great expense, so much the better, as Portland cement is slow in hardening, and it is desirable that it should be guarded as much as practicable in the early stage from the baking influence of an Indian sun.

All the arrises of the blocks were chamfered to the extent of three inches, and the faces and backs panelled, both at top and bottom, (for sake of close setting,) except in the case of oblique blocks, which have panels only at the top.

The moulds were made of 3-inch English pine, well tied together by iron straps, and bolts running from side to side, five through the block, and eight outside through the ends of the frame (four on each side). The middle bolts were drawn out by means of screws, six hours after the block has been made, and to facilitate this operation, they were made with a slight taper. The moulds were removed after 18 hours. These moulds answered very well for the number of blocks that had to be made for the breakwater work, but where blockmaking has to be done on an extensive scale, it would be desirable to make the moulds thicker, or of tougher wood than the English pine, the Indian teak or jungle wood (commonly called *cutch* or *ben teak*) would suit well. Great attention should be paid to the fixing of the frames properly, and to ensuring their tightness by caulking or other means, as important aids to the solidity and strength of the blocks.

For lifting the blocks, two T-headed lewises were used. The cups for the recesses for the lewises to turn in, were made of 1½-inch planking, either of jungle wood or pine, the tops being invariably made with the soundest and strongest wood. These were fixed in the bottom of the mould, at the right distance apart, according to the length of the lifting saddle. Into the slits cut in the tops of the cups, were placed, in a vertical position, coinciding with the centre of gravity of the block, the lewis moulds, which may be either of hollow cast-iron or solid wood, as both the kind answered well here. To obviate the setting hard of the lewis moulds, they were lifted up a little, and dropped in again in their places four hours after the making of the block, (by which time the lower concrete sets so hard, as not to fall in,) and finally removed after twelve hours.

The blocks were made on a platform of concrete prepared for the purpose, in such a way that they stood at the slope in which they were to be lifted, and set in the work. They were placed lengthways in six

A





rows, three on each side of the centre railway line along which they were conveyed to the breakwater.

Half an inch of fine dry sand (sea sand answered here very well) was spread over at the bottom of the mould, to prevent the concrete of the block from sticking to the surface of the platform, which was covered with ordinary lime concrete: experience, however showed, that six inches of Portland cement concrete for the platform, would have been better, and more economical in the end, by entailing less cost of repairs, also that the retaining walls forming the different levels in the platform, should have been somewhat thicker, to resist bulging out under the weight of the blocks, although no accident occurred from this cause.

The blocks were placed so as to lean on each side towards the centre line, being the only arrangement by which so large a number of rows could be commanded by the machinery of the "Goliath" steam hydraulic travelling crane, by which when required for use, they were lifted on to the trucks for conveyance to the breakwater. The lift of the "Goliath" ram not exceeding 3 feet 2 inches, the levels of the block ground and railway line were arranged to suit. The skips of concrete and the block moulds, were lifted by the hand travelling cranes, formerly used on the Napier Mole Bridge and Jetty Works, and which were somewhat altered by the addition of projecting beams and open ends to suit them to their present work.

Eight blocks per day were frequently made with three mixers, actually working only about six hours daily, the remainder of the day being occupied by shifting and preparing block moulds, measuring materials, and cleaning up ground, &c. Eighteen moulds sufficed to make this number of blocks daily and regularly.

The Portland cement was of first rate quality, and was all ordered out on indents through the Secretary of State, and subjected to testing before leaving England by Mr. Parkes, the Consulting Engineer for the Kurrachee Harbor Works. Most of it was used in a short time after its arrival here, but some which is still on hand is keeping well, and there has not been the slightest deterioration in its strength, though the setting is rather slower.\*

The strength and solidity of the blocks, due greatly to the excellent materials and machinery for mixing, and not a little also to the unceasing

\* See No. LXXXVIII. of the "Professional Papers on Indian Engineering," Second Series.



attention and practical skill of Mr. George Lowe, the Foreman of mason work, left nothing to be desired. In illustration of their strength, it may be mentioned that one of the 27 ton blocks was lifted safely (as a test) in a week from the day it was made. The lifting motion of the "Goliath" is very smooth however, and it would not be advisable to use blocks so freshly made, for setting by the "Titan," though one month may be considered ample for the setting as already stated.

*Cost of one block of 16 cubic yards.*

	Rs.	A.	P.
9½ Casks of cement, at Rs. 8-0-0 each, or about Rs. 45 per ton, being the highest price paid during the progress of the work, .. .. .	74	10	8
180 Cubic feet of Layarie sand (brought across the harbor from about five miles off), at Rs. 4-4-0 per 100 cubic feet, ..	7	10	5
252 Cubic feet shingle, at Rs. 1-13-0 per 100 cubic feet, ..	4	9	1
144 Quarry lumps, at Rs. 2-4-0 per 100 cubic feet, .. ..	3	8	10
Labour of making block, .. .. .	13	4	0
2 Wooden cups for lewis recesses, .. .. .	1	8	0
Working expenses of concrete mixing engine, exclusive of fuel which was supplied by the cement casks, .. ..	1	7	9
Locomotive Engine haulage for shunting sand, .. .. .	0	8	0
Charges on account of work establishment, including Time-keepers, Chowkedars, Mistries, Carpenters, &c., and expenses connected with the working of the machinery, repairs of moulds and wagons, and cost of keeping railway lines in repair, .. .. .	14	15	7
Total current expenses for one block,..	121	13	4
Allow for proportion of cost of machinery and plant employed in block making, .. .. .	40	0	0
Total for one block, .. .. .	162	0	0

$$\frac{122}{16} = \text{Rs. } 7\frac{1}{2} \text{ per cubic yard current expenses.}$$

$$\frac{162}{16} = \text{Rs. } 10\frac{1}{4} \text{ per cubic yard including allowance for plant.}$$

In conclusion, I desire to acknowledge the valuable aid of Mr. Bhumaya Saenna, Supervisor 1st Grade, not only in the preparation of this article, but in the work to which it refers.

W. H. P.

May, 1874.

## No. CXXXV.

## PITT'S PROPOSED DREDGERS.

[ *Vides* Plates LXXXVIII., LXXXIX., XC. and XCI.]BY SERGT. W. H. PITT, R. E., *Overseer, P. W. D., Bombay.*

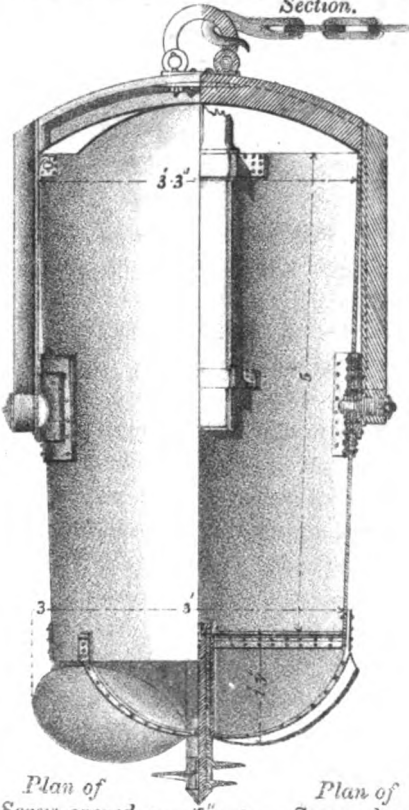
ALTHOUGH it is not actually necessary, in all cases, to drive a well or block down to rock, or even to good stiff clay, when the depth is so very great as is often the case; yet the masonry should obviously, in all cases, be taken down, not only until the amount of friction existing shall be such as to hold the well sufficiently firm and suspended to build upon, but until there remains not the slightest chance of its ever being undermined, or even so much exposed by any unusual velocity of water as to lessen beyond a certain extent the friction that buoys up the whole mass of masonry: to pass beyond this limit, must unquestionably result in a sinkage, the effect of which, when not uniform throughout, is universally too well known to require any elucidation; hence the absolute necessity of carrying the wells or blocks for foundation sufficiently deep, when a stratum of rock, or hard moorum, &c., lies beyond ordinary reach.

Perhaps of all the difficulties that have to be surmounted in the construction of masonry bridges, when the foundations have to be carried down to a very considerable depth in silt or loose sand, &c., with a view to ensure the stability of the superstruction, the sinking of wells or blocks may (it is presumed) be legitimately classed as one of the most tedious and important, more especially when the work has to proceed in water; in which case, the work can only advance, under the most favourable circumstances, but slowly, owing partially to the necessity of removing the soil from within the well, cautiously and uniformly, so as to admit of its gradual and even descent, as also to the very limited space for operation.

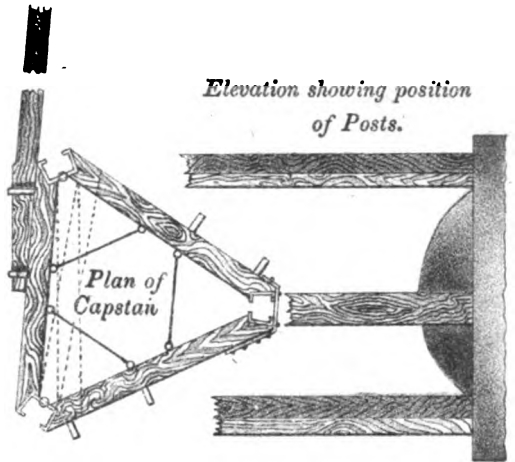
The well known *Jham* is the machine by which blocks have been generally sunk heretofore, but which has now been superseded by other instruments, the merits or demerits of which it is not the object of this paper to discuss. Suffice it to say, that it is proposed to effect the very same result aimed at in the machines alluded to, but only in about half the time, by means of the Auger Dredger, or the Cylindrical Dredger, proposed to work in conjunction with the "Boulder lift," (*vide Plates*, from which it will be perceived that the three designs seem extremely simple, and would prove no doubt to be so in reality.) The general description and mode of application of each of these will be fully demonstrated further on; the advantage or disadvantage of the one or the other can only be approximately estimated by theory, and in absence of an opportunity to prove their practical applicability and utility, it may not be considered redundant or out of place here to remark, that the Auger Dredger was the first to suggest itself, as being what was supposed to be wanting in the sinking of wells; accordingly it was drawn out, and a model (rough) made on a scale of about  $1\frac{1}{2}$  inch to a foot. The cylinder of this was of *block tin*; the bottom, including the cutting bits, of wood; this it was deemed would suffice to show any defects in working. The model was duly subjected to a trial, resulting as follows, viz.:—*1st*, In loose sand, three parts full in about 9 or 10 horizontal revolutions; *2nd*, Nearly full, in partially consolidated sand and earth, in 8 revolutions; *3rd*, When half full unfortunately came in contact with a stone which being too large to pass into the cylinder, carried away the cutting bits of the model, (which as remarked above, were of wood, and from the form of the bits it will be readily understood how they came to be cut across the grain of the wood, scooped out as they were from a solid piece;) from this very limited experiment, no very important conclusions could have been expected; however, the result was that it was thought advisable to provide something to overcome the like obstruction which probably might occur on a larger scale; accordingly the boulder extractor was invented. The third design, was the Cylindrical Dredger proposed to effect the same object as that of the Auger Dredger, and although it has not been tried in any shape or manner, yet (it is presumed) there exist good grounds to suppose that it will work in any kind of soil, (*i. e.*, in any alluvial deposit, stiff clay or mud, &c.,) with facility, and even better perhaps than the Auger Dredger.

# PITT'S PROPOSED AUGER DREDGER.

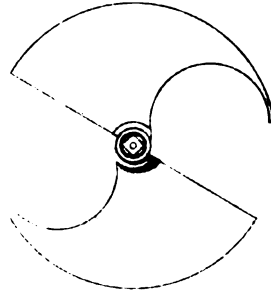
Half Elevation. Half Longitudinal Section.



Elevation showing position of Posts.



Plan of Shutter.



Section of Shutter

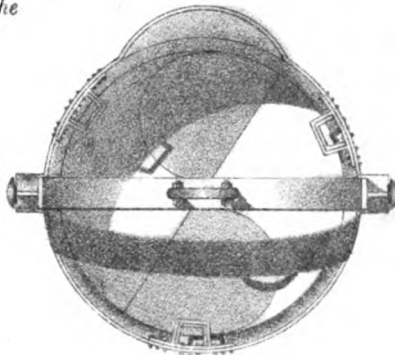
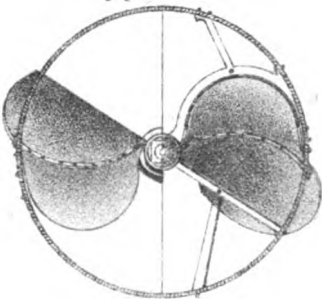
Plan of Screw opened. ← 12" →

Plan of Screw closed.

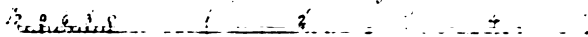


Plan of bottom of Dredge showing position of cutting bits: half with the bottom covering plate removed.

Plan of Dredge showing vents closed.



Scale, 1/2 inch to the foot.





It is calculated that the Auger Dredger will take 10 minutes in filling, 5 minutes in being let down and drawn up, 5 minutes for unloading, &c., giving a total of 20 minutes. The contents of the dredger when full, after deductions, will equal 38 cubic feet; allowing an average of 100 lbs. to the cubic foot, the weight of each cargo will equal 1.69 tons; hence a gradual vertical pressure from this weight plus the weight of dredger, &c., will be exerted on the descending masonry. This force, it is thought, must obviously tend satisfactorily, to bring a block down to its requisite bearing; which should take place as the dredger is being hoisted up, and the silt closes up the vacuum.

In *Plate XCI.* the silt is shown as being removed by manual labour according to the usual custom, yet this system is far from being advocated in practice in conjunction with either of the proposed dredgers, especially in the case of extensive works, in which case it would be found a very slow and expensive method, inasmuch as the dredger, it is thought, would in many instances, have to wait for a place to dispose of its contents, owing to the limited space for operation, and the quantity and quick return of the dredger. It would therefore perhaps be found an advantage to adopt the use of a pair of small trucks, each equal to about the contents (or little more) of the dredger; and made to revolve so as to admit of its contents being expelled at once without much labour; the two trucks to be connected so that as the full one descends it pulls up the empty one, to run on a kind of platform slightly elevated at the end nearest the site of operation, so as to give a sufficient velocity to the loaded truck; thus the system of manual labour would be greatly reduced, and the work enabled to proceed much more rapidly than otherwise.

---

*General description of Auger Dredger [Plate LXXXVIII.]*

The proposed Auger Dredger will consist of a cylinder, having an interior diameter at top and at bottom of (respectively)  $3\frac{1}{4}$  and 3 feet, and measuring 5 feet in height; the bottom of dredger will be fitted with cutting bits, back action screw, &c., to be firmly attached to the cylinder; the arrangement of the cutting bits, &c., will be as follows, viz.:—The top of the projecting centre hollow tube will be connected to the cylinder by angle iron; the bits will be twisted and cut, so as to form the necessary hollow shape, and so as to lap partially around the hollow tube at the centre, and

on to the angle-iron and cylinder, in which position they will be firmly secured by rivetting, and further by the two iron straps, inside and out; the whole of the bottom, excepting the two vents, will be covered; the back action screw will be connected with the moveable shutters by means of the axle rod, which will revolve backwards and forwards through the tube: the screw will be formed in two parts, to work on two separate and opposite hinges, by which arrangement it will be made to act in two directions, viz., forward and backward; by the former motion, it will act as a lever in drawing down and graduating the grip of the cutting bits, and by the latter, the screw will open out and offer resistance to the revolving motion of the dredger, by which the shutters will be made to work on to and close the vents, so as to keep the contents of the dredger from evacuating on being hoisted up.

The dredger will be supported by means of two suspending rods, one on either side, connected at top by a cross piece lightly curved, having a ring fixed at the centre. The other extremity of each rod will be attached to the cylinder just below the centre,—the axis of the vertical revolution of the dredger, when disposing of its contents.

The machine will revolve horizontally by means of three poles, fitted so as to slip and unslip in sockets attached to the inside of the cylinder. A capstan, provided with three long hand-spikes, will be attached to the top, whence motion will be communicated to the dredger.

*The cylinder* will be of good  $\frac{1}{2}$ -inch sheet iron, well rivetted together.

*Suspending rods* and top cross beam of  $3\frac{1}{2}$  inches T-iron.

*Cutting bits* of  $\frac{1}{4}$ -inch sheet-iron.

*Tube and axle rod* of good wrought-iron.

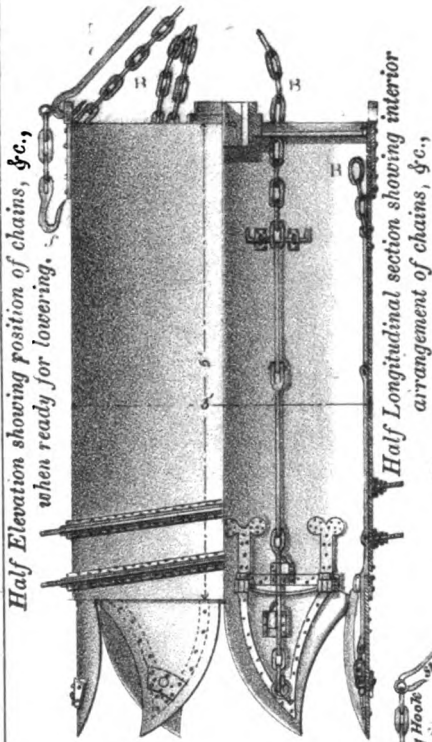
*Screw* of cast-iron, free from all kinds of flaws.

*Rivets* of good wrought-iron.

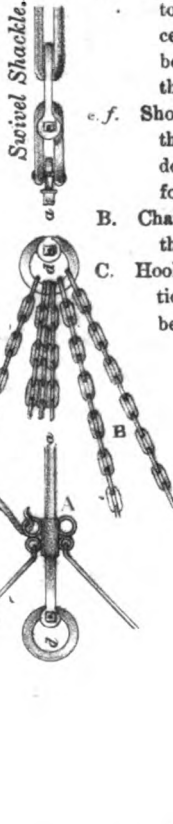
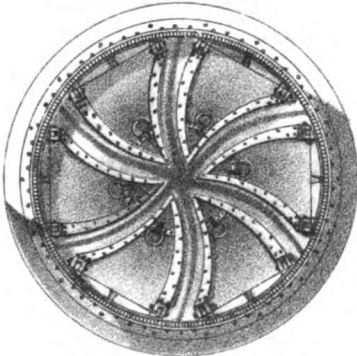
*Woodwork* of pukka teak.

*Mode of application*, [Plate XCI.]—Shear legs will be so arranged that their common apex may be as nearly as possible perpendicular over the centre of the well. A tackle fall, consisting of a double and single block, will be suspended. The dredger will be attached, and let down after having fixed the poles when the dredger comes in contact with the soil, the capstan will be adjusted, and the instrument put in motion,—the tackle fall still remaining attached, which by the aid of the swivel shackle will not tangle; it having been ascertained that the dredger is full, two or

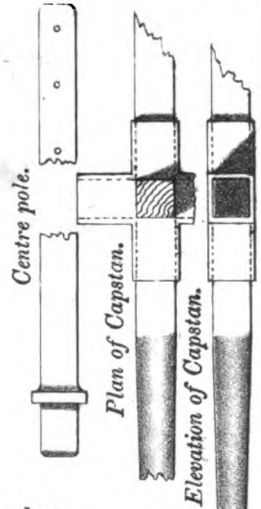
PITT'S PROPOSED CYLINDRICAL DREDGER.



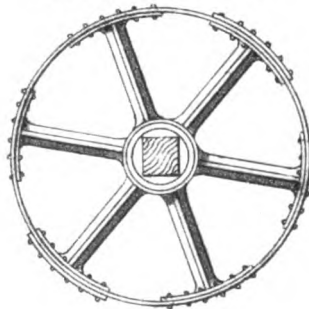
Plan of bottom of Dredger showing doors neatly closed.



- REFERENCES.
- A. Hook of suspension rods proposed to work up and down on the centre rod marked *a*, which will be immediately connected with the Swivel shackle.
  - e. f. Short hooks are for suspending the Dredger when the bottom doors are opened. Long hooks for unloading.
  - B. Chains connected with the doors there being one to each door.
  - C. Hooks for keeping Dredger in position whilst the centre chains are being let down when unloading.



Plan of top of Dredger.







three back turns will be given to the dredger, by which action the screw will have closed the shutters. The capstan and poles having been removed, the dredger will be hoisted up, by means of the windlass fixed at the foot of the leg of the shears, (*see Plate XCI.*) The dredger on being brought up to the required heights, will be made to revolve in a vertical direction, and discharge its contents, after having released the catch connecting the rods and cylinder on either side. The dredger will be ready for another descent on being righted, poles refixed, vents opened, and screw closed.

---

*General description of Cylindrical Dredger [Plate LXXXIX].*

This Dredger will consist of a cylinder 3 feet in diameter, and 5 feet in height, (interior measurements,) having a strip of iron 6 inches wide twisted and fastened one and a half times round the bottom edge of the cylinder, outside, at a pitch of 1 in 10, so that in the action of revolving horizontally, the dredger is either being drawn up, or into the soil, according to the direction of motion. The bottom of the dredger will be fitted with six curved-edge doors, meeting in the centre, and over-lapping  $1\frac{1}{2}$  inches on the one edge when closed. The doors will hang down when open, and resemble the teeth of a saw in appearance, as also in their action when working on the soil; they will open and shut by means of chains so arranged that the doors will be kept open, when so required, by a kind of double-branch bolts connected one with each of the chains, to slide into their respective sockets, fixed one on the inside of each door, and the other immediately above it, on the inside of the cylinder, against which the chains will be kept in place, so as not to impede the motion of the dredger; the top of each of the chains is to be provided with a cross bar, to admit of its suspension against the inside of the cylinder, as also to distribute the weight of the load on the cylinder (when full) by catching under the arms or spokes that splay out from the centre on top (in the shape of a wheel) into centre of this 'wheel' a long pole will fit, by which, and the capstan, the dredger will be made to revolve. Two eyes fastened to the top edge of the cylinder, opposite to each other, will be provided, into which the suspending rods, that slide up and down, will be hooked.

*Mode of application, [Plate XCI.]*—Shear legs will be arranged, as suggested in the case of the Auger Dredger. The machine will be attached to the short length hooks of the suspending rods, so as to admit of

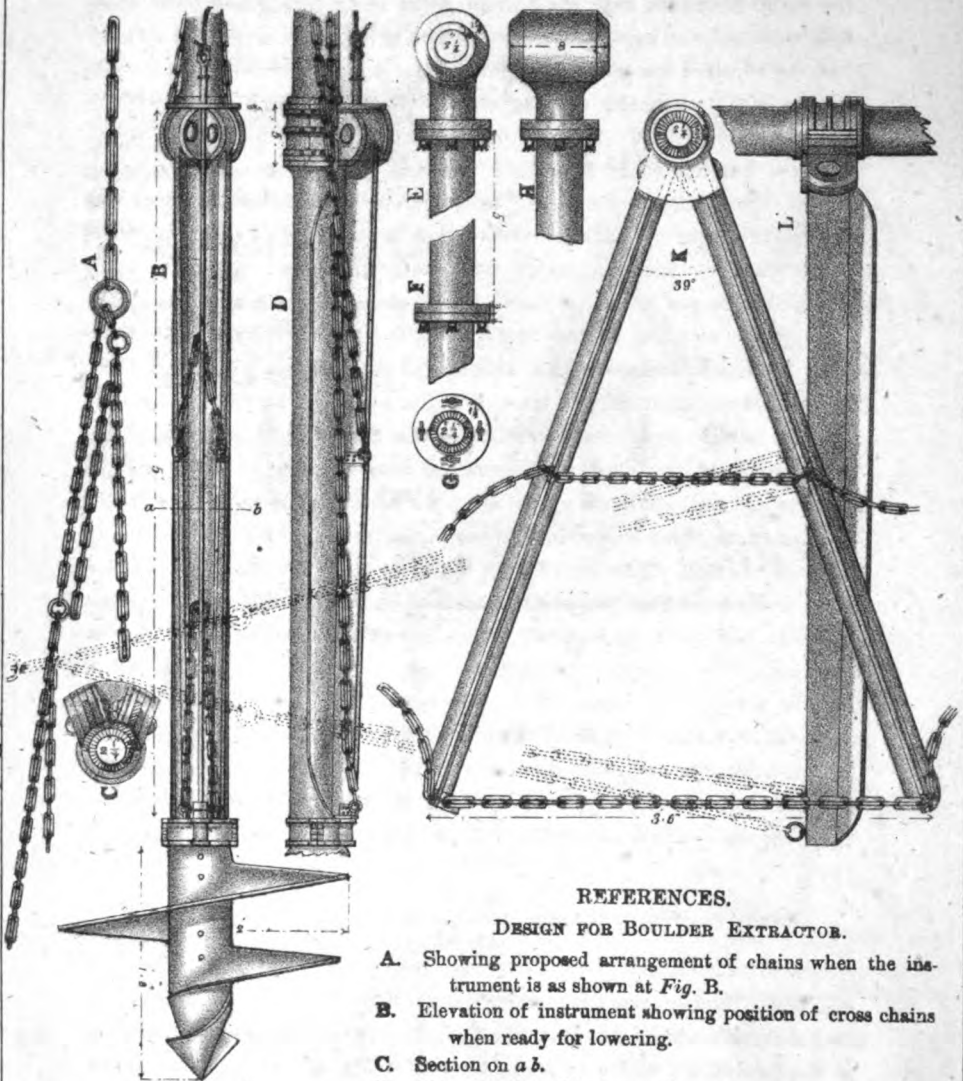
the chains connected with the bottom doors being disengaged; the doors will be opened, and kept so by forcing the bolts into their respective sockets. Having adjusted the centre pole, the dredger will be lowered to the bottom of the well, when the capstan will be fixed, the tackle fall will be slacked off sufficiently to allow of the weight of the dredger falling on the silt, but not so as to unhook the rods, (in case it may be required to lift the dredger up a little, to avoid any slight obstruction.) The dredger will now be made to revolve, and kept up until nearly full, when the suspending rods are to be unhooked completely; this effected, a strain will be put on to the tackle fall gear, which will now fall on the long chains attached to the doors, resulting in the withdrawal of the bolts from their sockets. The dredger will be again made to revolve one or two turns more in the same direction as before, by which,—and the gradual strain from the tackle fall,—the door will be made to close. The action of the dredger will now be reversed, by which it will be unscrewed, as it were, from the soil; the power on the gear will be increased, until the whole weight is suspended, when it will be hoisted up clear of the well. The long length hooks of the suspending rods having been hooked on, the two chains attached and suspending from the two opposite legs of the shears will be hooked into the eyes connected with the rods. The necessary preparation having been made for the reception of the silt, the gear is slacked off, by which action the doors become opened, and the contents discharged simultaneously. The short length hooks having again been adjusted, the bolts refixed into their respective sockets, and the centre pole placed into position, the dredger will be lowered into the well, where the same process will be repeated.

---

*General description of the proposed Boulder Extractor [Plate XC.]*

The Boulder Extractor will consist of a small cylinder of  $2\frac{1}{2}$  inches and  $3\frac{1}{2}$  inches interior and exterior diameters, and 10 feet in length, having two moveable arms 5 feet long attached, furnished with suspending chains: at the bottom end of the cylinder, a screw of 2 feet diameter, and 1 foot 8 inches long, will be fastened; cylindrical shanks in lengths of 5 feet, attached by their flanges will be connected to the other end. Motion to be communicated by means of a capstan, in the shape of a long bar passed through the eye of the head, which will constitute the top and last shank,

PITT'S PROPOSED BOULDER EXTRACTOR.

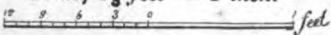


REFERENCES.

DESIGN FOR BOULDER EXTRACTOR.

- A. Showing proposed arrangement of chains when the instrument is as shown at Fig. B.
- B. Elevation of instrument showing position of cross chains when ready for lowering.
- C. Section on a b.
- D. Side elevation of instrument.
- E. Head by which the screw is made to revolve and penetrate.
- F. Portion of shank showing method of fastening two length.
- G. Section of shank and plan of flange, showing arrangement of nuts.
- H. Elevation of head of instrument.
- K. Plan showing arms of instrument extended, as when under a stone.
- L. Elevation showing arms of instrument extended, also position of chains: (dotted.)

Scale,  $1\frac{1}{2}$  feet = 1 inch.





PITT'S PROPOSED DREDGERS.

REFERENCES.

ROUGH SKETCHES. Showing three positions of Cylindrical Dredger during its proposed operation in Well or Block sinking, also a sketch of Boulder Extractor, as proposed to be applied in the clearing out of a Boulder from a Well.

FIG. 1.—Dredger loaded its bottom partially closed.

FIG. 2.—Dredger loaded and hoisted up ready to discharge its contents.

FIG. 3.—Dredger unloaded.

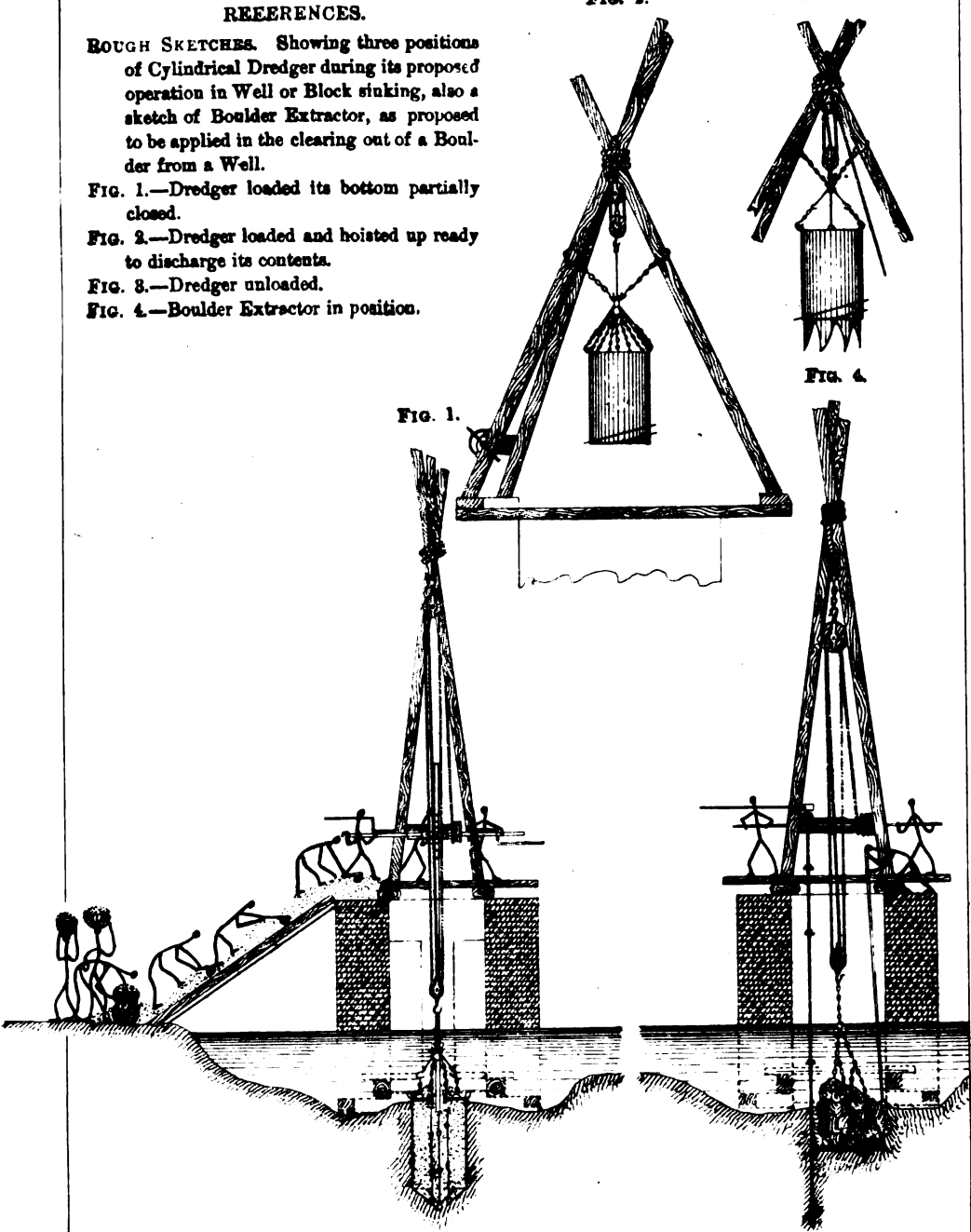
FIG. 4.—Boulder Extractor in position.

FIG. 2.

FIG. 3.

FIG. 1.

FIG. 4.





according to the depth the instrument is proposed to be worked at. The main cylinder and screw will be the only parts (including the shank) that will revolve, whilst the arms will remain in the one horizontal position. The upper ends of the arms will fit into, and work between two flange pieces, projecting out at an angle of 39 degrees, so that on the arms being drawn up, they will diverge from one another at that angle: they will also be so shaped, as to admit of their falling and closing round the main cylinder, (as shown in *Figs. B, D, Plate XC.*), in which position they will be detained by a rod passing through the eye at the extremity of each arm and into the lower moveable band; through which,—and the upper band that encircles the cylinder between the two shoulders, where it will be secured by overlap hinged straps,—the cylinder will revolve when the arms hang down vertically against the main cylinder; the chains inside will be kept from obstructing the descent of the instrument, by being tucked up behind the centre rod that keeps the arms in place, and the outside chains by being pulled up sufficiently tight, (*see Figs. A, B, D, Plate XC.*)

*Mode of application, [Plate XCI.]*—Having ascertained the place and depth of the boulder it is proposed to lift up, the instrument will be prepared accordingly, and will be let down as nearly perpendicular as possible into the well, so that the screw at bottom will just touch the stone, with the arms of the instrument facing inwards; in which position it will be screwed down, until the lower band is about in line (as near as can be guessed) with the bottom of the stone, at which point in the operation, the centre rod will be entirely withdrawn, leaving the arms and chains released, the latter of which will be slacked off, so as to offer as great an impediment to the downward progress of the instrument as possible. On the screw being again put in motion in the same direction as before, the cylinder (including the shank) is being pulled down after it, whilst the arms are being expanded out obliquely; which continues until the limbs are horizontal, in which position the suspending chains will have formed around the stone, (*see dotted lines in Fig. L, Plate XC*). The *tackle fall* will now be adjusted and worked upon, at the same time the action of the screw will be reversed, and by their united forces the boulder will be suspended; when it is known that the weight of the stone is being borne up by the instrument and the gear, it will be ascertained by long iron bars whether any part of the stone lies underneath the masonry, and if so, it will be made to swing clear around



the instrument by levers. When all is clear, it will be hoisted up and disposed of, as may be found most convenient.

The instrument will be again ready to descend on the limbs being reclosed and fastened, and the chains re-adjusted as before suggested.

NOTES.—The three designs are truly original ones.

The terms used throughout are as technical as possible, and will be generally understood (it is presumed).

There exist no known grounds for objections to a general enlargement or reduction in the size of either of the Dredgers, as also in the Boulder Extractor.

Most of the details, such as the chains, &c., have been sketched in without reference to dimensions.

W. H. P.

## No. CXXXVI.

## HOLLOW WALLS OF BRICKWORK.

[ *Vide* Plate XCII ]

*Memo. by* MAJOR C. S. THOMASON, R.E., *Supdg. Engineer, 1st Circle, Provincial Works, N. W. Provinces.*

*3rd September, 1874.*

THE objects sought to be attained when building walls hollow are :—

- (I). Economy of material; which is obvious.
- (II). Such economy as will frequently render it as cheap if not cheaper, to build the structure pukka, instead of kuchha, or kuchha-pukka.
- (III). To give a wall, which, as regards insuring a low temperature within a building, shall be on a par with a kuchha wall very much thicker.
- (IV). Lightness of superstructure; which may frequently be of great importance, where doubts exist as to the reliability of the soil on which the structure is to rest.
- (V). Perfect bond and security against the use of bad material, the whole of the material being open to inspection at any time. This is not the case with a solid wall, which in the absence of inspection, might be filled with rubbish inside.

This form of construction is obviously not suitable where weight is necessary, as for instance in an abutment to an arch; and one or two precautions should be observed in adopting it where it is applicable, such as :—

- (i). The course from which it starts should be quite level, smooth, and of the very best brickwork, or masonry: particular attention being paid to the lime used, so as to be secure from the inroads of vermin.
- (ii). The *tie* bricks should be thoroughly pukka, otherwise wind and rain combined will tell through the wall at the tying points.

Where such are procurable, perforated or hollow bricks will be found to enhance all the advantages of hollow walling.

The principle is capable of extension in many ways, which will readily suggest themselves in practice: for instance, in building a high wall where batter is required. The building of such a wall solid might necessitate a great deal of brick cutting; whereas, if hollow, the tie bricks alone need be cut, and even in the ties, a great quantity of half and quarter bricks may be utilized, that would otherwise be discarded.

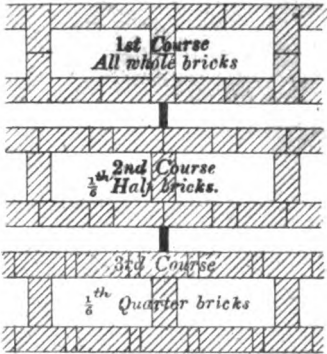
Filling the pockets at the base with *dry* material, will much increase its stability against wind.

The writer has successfully used the 18-inch bond here shown, in a lower storey 14 feet high, with a second storey of the 14-inch hollow bond. Of the 10 $\frac{1}{2}$ -inch hollow bonding he has had no personal experience, but it is common in England.

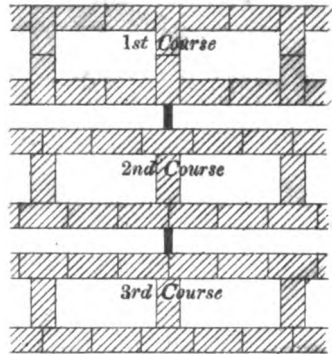
C. S. T.

# HOLLOW WALLS OF BRICKWORK.

**FIG. 1.**  
18" Hollow wall, saving  
4 out of 10 bricks.



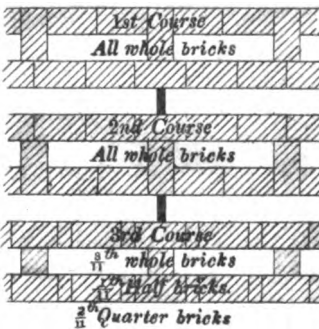
**FIG. 2.**  
18" Hollow wall, built entirely  
with whole bricks.



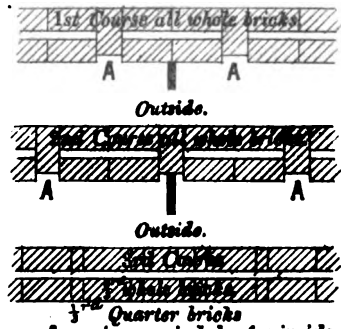
**FIG. 1.**—Shows the bond for a two brick wall, when it is desirable to use up half and quarter bricks.

**FIG. 2.**—Shows the bond for a similar wall, using only whole bricks. In practice I would recommend three courses, according to Fig. 1, alternately with the courses according to Fig. 2.

**FIG. 3.**  
14" Hollow wall, saving 2 out  
of 7½ bricks.

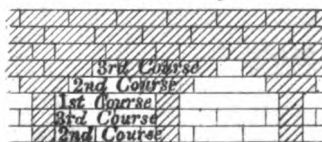


**FIG. 4.**  
10½" Hollow wall.  
Outside.



The recesses A serving as pin holes for inside plastering.

**FIG. 5.**  
Showing closing in of the hollows by  
a vertical section of wall.



**N.B.**—Closing in must commence at least five courses below wall-plate. The courses noted above are according to Fig 2.





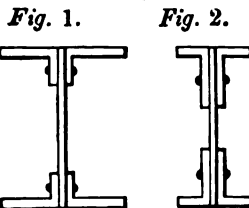
## No. CXXXVII.

## ON ANGLE-IRON FLANGES.

BY CAPT. ALLAN CUNNINGHAM, R.E., *Hony. Fell. of King's College Lond.*

THE following question has been recently submitted to the Author: its solution may interest the profession in India.

“It is proposed to construct a *small* wrought-iron Girder of a symmetric I-section, the flanges to consist each of two similar angle-irons with arms of equal thickness but of *unequal length*. How should the angle-irons be placed, *i. e.*, with the long arms *perpendicular* to the Web (as in *Fig. 1*), or *parallel* to the Web, (as in *Fig. 2*)?”



It was stated by the proposer that the practice of some practical Girder makers in India differed on this point. There can be no doubt however as to the Theory of the subject.

The universally accepted Theory of Transverse Strain shows that in a Beam under pure Transverse Strain—without twisting—material is *most favorably placed* for the utilization of its full powers of Resistance when placed *as far as possible from the neutral axis* in each section.

On this sole principle depends the economy of massing the material of metal girders in the form of Flanges.

It follows therefore that in two Girders of type proposed, similar in

all respects *save in the position* of the angle-irons forming the flanges, which are placed as in *Figs. 1 and 2*, that arrangement is certainly the **STRONGER** and the **STIFFER** in which the long arms of the angle-irons are placed *across* and *at the ends* of the Web (as in *Fig. 1*), because in this arrangement as much of the flange-material as possible is placed at the greatest possible distance from the neutral axis.

The position of the rivets may be made apparently somewhat more favorable in the arrangement of *Fig. 2*, than in that of *Fig. 1*, because they could be placed nearer the neutral axis in the former case, that is to say the rivet-holes could be bored through a part of the material under less strain, and in which therefore their weakening effect is less important than is possible in the latter case.

But with good riveting the compression-flange is not sensibly weakened by the rivet-holes, and in a Girder of proposed type (with equal flanges) the tension-flange has an unavoidable excess of strength, so that the Working Strength of the Girder depends in fact solely on the compression-flange. Thus the position of the rivets does not sensibly affect the previous conclusion as to which is the strongest arrangement.

The difference in **TRANSVERSE STRENGTH** of the two arrangements may be considered to be measured by the difference of Working Resistance of the two cross-sections to the longitudinal strain of compression, and may be found—on the usual Theory of Transverse Strain,—viz., that “the longitudinal stress-intensity is uniformly-varying with the distance from neutral axis”—as follows:—

Let  $s_c$  = safe or working crushing stress-intensity, usually expressed in tons per square inch.

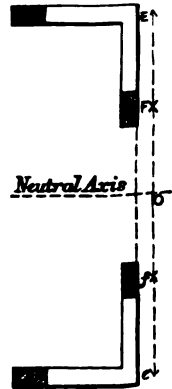
$a$  = difference of sectional areas of the two (unequal) arms of each angle-iron, usually expressed in inches.

= area of part shaded in sketch (*Fig. 3*).

Now since the two cross-sections (*Figs. 1 and 2*) differ only in the interchange of the shaded parts (*Fig. 3*), whose areas are  $a$  in each of the angle-irons, it follows that

$$\left. \begin{array}{l} \text{Difference of Working Crushing Re-} \\ \text{sistance of the two cross-sections,} \end{array} \right\} = \left\{ \begin{array}{l} \text{Difference of working crush-} \\ \text{ing resistance of the area } a \\ \text{placed at E, and of the area} \\ \text{a placed at F,} \end{array} \right.$$

*Fig. 3.*



and by the property of uniformly-varying pressure—which is the same as for fluid pressure,

$s_c$  = working or safe pressure-intensity.

= pressure-intensity along extreme layer at a distance  $\frac{1}{2}d$  from the neutral axis.

$$\therefore \text{Working Crushing Resistance of a placed at E} = s_c \cdot \frac{OE}{\frac{1}{2}d} \cdot a, \text{ tons.}$$

$$\text{Working Crushing Resistance of a placed at F} = s_c \cdot \frac{OF}{\frac{1}{2}d} \cdot a, \text{ tons.}$$

$$\begin{aligned} \therefore \text{Difference of Working Crushing Resistance of the two sections,.....} \} &= 4 \times s_c \cdot \frac{OE - OF}{\frac{1}{2}d} \cdot a \\ &= 8 \times s_c \cdot a \times \frac{FE}{d}, \text{ tons.} \end{aligned}$$

It would not be difficult to show in the same manner, that—under the usually accepted Theory of Transverse Strain the

$$\begin{aligned} \text{Difference of Moment of Resistance of the two sections, .....} \} &= 8 \times s_c \cdot a \cdot \frac{OE^2 - OF^2}{d} \text{ inch-tons.} \\ &= 8 \times s_c \cdot a \times \frac{eF \cdot FE}{d} \text{ inch-tons.} \end{aligned}$$

A. C.





## Correspondence.

---

*To the Editor Professional Papers on Indian Engineering.*

DEAR SIR,—Perhaps the following note may be thought to bear on Major Corbett's theory, that irrigation would become unnecessary in Upper India if deep cultivation could be introduced.

In the Banu valley, the low lands not only get an abundance of water from the Koorum river, but with the water a large quantity of very fertile deposit. These lands are carefully and deeply cultivated, principally by the spade.

The higher lands which get either no irrigation at all, or an uncertain supply from mountain torrents, are merely scratched in the usual Indian fashion. Does not this seem to point to the conclusion that deep cultivation is only practicable where irrigation renders the cultivator certain of a return for his outlay ? and that so far from deep cultivation being a substitute for irrigation, it is only on irrigated lands that deep cultivation can be profitably employed.

Yours truly,

EDWARDESABAD, }  
13th January, 1873. }

J. B. LINDSELL, LIEUT., R.E.,  
*Assistant Engineer.*



## Correspondence.

---

*To the Editor.*

SIR,—On reading Paper LXV. on the Margohi Cement, it has occurred to me to suggest to the gentlemen engaged on this interesting investigation, that their experiments would be much more satisfactory and generally available for comparison, if they adopted a procedure similar to that commonly used at home for such enquiries, so as to throw their results into the same form as the great mass of data already accumulated regarding the cements now in common use, particularly Portland, the most important of any, (*vide* Minutes of Proceedings of the Institution of Civil Engineers, Vols. XXV. and XXXII).

I would also venture to remark that the experiments recorded, pages 18-20 of your February Number, are hardly sufficient to justify the conclusion that the new cement is equal to English Portland; it is quite possible it may be so, but cannot be taken as proved. Only one experiment was, if I understand right, made with each kind of cement, and the method and apparatus described are both very liable to have their results affected by many things, besides the strength of the cements; now with the most perfect apparatus yet devised or used, it is generally only considered safe to generalize from the average of a large number of experiments.

It is not quite clear whether the fracture took place through the mortar in any of the experiments; if the mortar merely separated from the bricks, the results are rather indications of the goodness of the bricks and of the workmanship in putting them together, than of the relative strengths of the cements. I am inclined to think that the results, for Portland at all events, must have been vitiated in some such way, because an ultimate tensile strength per square inch, ten or twelve times as great as that now assigned to a joint made with it, is commonly obtained from it (and indeed insisted upon as a matter of contract) at home; and as the sample under trial is stated to have been "just imported and in good condition," it seems scarcely possible that so great a deterioration should have taken place. The precaution was probably taken of using a mixed sample from different packages, otherwise the variations in quality to which single packages are subject, are sometimes quite sufficient to seriously affect the validity of results obtained from them.

W. INNES, CAPT., R.E.

SINGAPORE, }  
10th April, 1873. }



## Correspondence.

---

*To the Editor "Professional Papers on Indian Engineering."*

SIR,—I would like, through your columns, to draw the attention of Engineers in India, to an article on Puzzolana, that appeared in "The Builder" of 26th September last. It is there stated that, "coal cinders, peat and wood ashes, *especially the last*, make puzzolana of good quality. They must be sifted ..... and stored in a dry place," &c. Now the failure of the Allahabad Barracks was attributed principally to the fact that wood ashes were mixed with the lime, and the Committee that reported on them, composed of Engineers of experience, laid particular stress on the fact. It may even be said that all the punishments that were meted out to the officials in charge, were based on the charge that they had not discovered the systematic mixing of wood ashes with the lime. Which are we to believe, and can we safely in future substitute wood ashes for soorkhee ?

It would appear that want of watering had far more to do with the want of tenacity of the mortar in those ill-fated buildings than the supply of ashes.

Yours faithfully,

**EXEC. ENGINEER.**









UNIVERSITY OF MICHIGAN



3 9015 07331 1022

